

# YK - ALL MODELS

INSTALLATION, COMMISSIONING,  
OPERATION AND MAINTENANCE

REVISION 2

035-19569-101 (0109)

## CENTRIFUGAL LIQUID CHILLER STYLE G

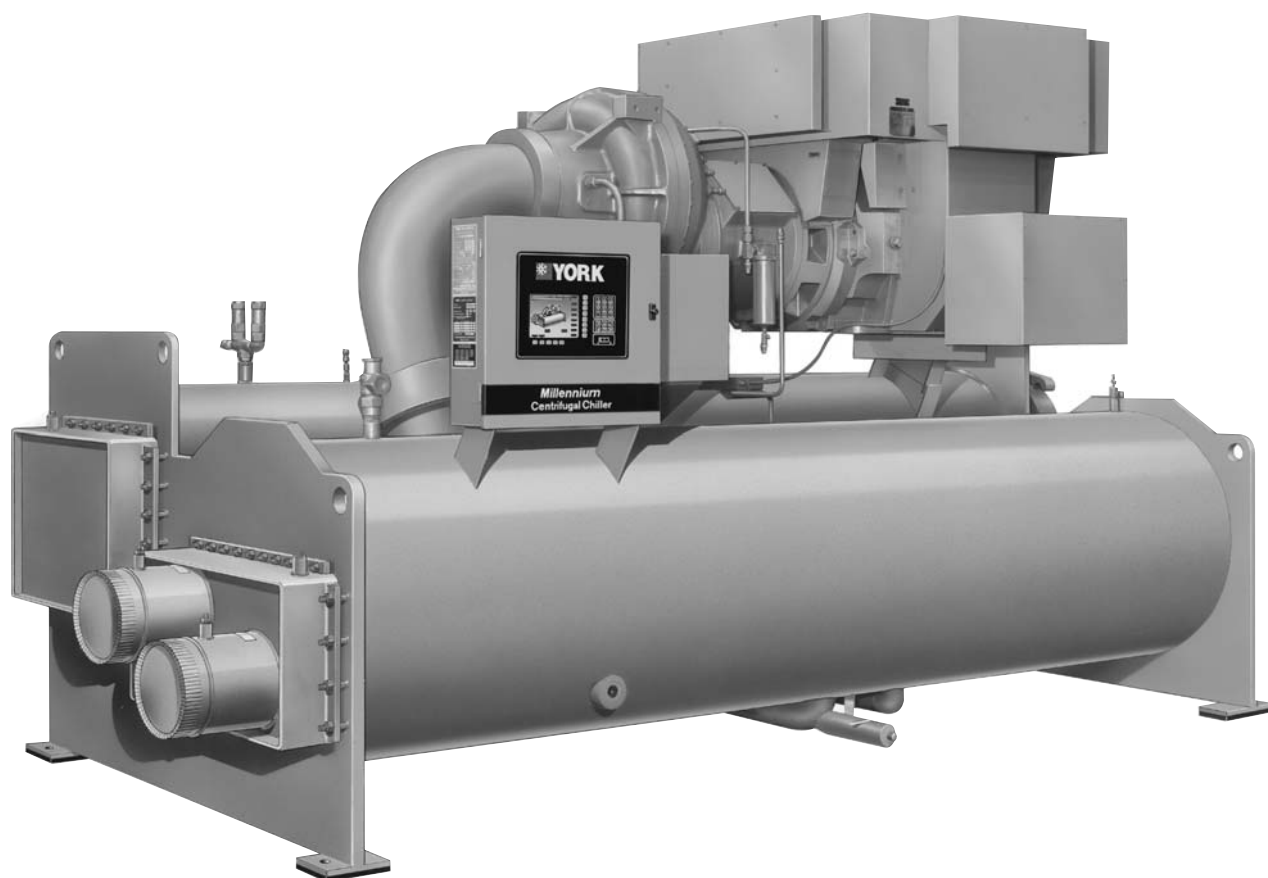

CE

R134A



## Table of Contents

<b>1 SUPPLIER INFORMATION</b>	<b>1-1</b>	<b>4 INSTALLATION</b>	<b>4-1</b>
1.1 Introduction	1-1	4.1 Location	4-1
1.2 Warranty	1-1	4.2 Motors	4-1
1.3 Safety	1-1	4.3 Foundation	4-1
1.4 Responsibility for Safety	1-1	4.4 Clearances	4-1
1.5 About this Manual	1-2	4.5 Rigging Unit to Final Location	4-1
1.6 Misuse of Equipment	1-2	4.6 Locating and Installing Isolator Pads	4-1
1.8 Safety Labels	1-3	4.7 Installing Optional Spring Isolators	4-2
1.9 Material Safety Data	1-4	4.8 Piping Connections	4-2
<b>2 PRODUCT DESCRIPTION</b>	<b>2-1</b>	4.9 Evaporator and Condenser Water Piping	4-2
2.1 General	2-1	4.9.1 Chilled Water Circuit	4-5
2.2 Capacity Control	2-2	4.9.2 Condenser Water Circuit	4-5
2.3 Compressor	2-3	4.10 Stop Valves	4-6
2.4 Compressor Lubrication System	2-3	4.11 Flow Switches	4-6
2.6 Graphic Control Centre (OptiView)	2-5	4.12 Drain and Vent Valves	4-6
2.7 Heat Exchangers	2-5	4.13 Checking Piping Circuits and Venting Air	4-6
2.8 Refrigerant Flow Control	2-6	4.14 Refrigerant Relief Piping	4-6
2.9 Options and Accessories	2-6	4.15 Unit Piping	4-7
2.10 Nomenclature	2-7	4.16 Control Panel Positioning	4-7
2.11 Range of Models	2-8	4.17 Control Wiring	4-7
<b>3 TRANSPORTATION, RIGGING AND STORAGE</b>	<b>3-1</b>	4.18 Power Wiring	4-7
3.1 General	3-1	4.19 Units with Solid State Starter or Variable Speed Drive	4-8
3.2 Shipment	3-1	4.20 Thermal Insulation	4-8
3.3 Inspection, Damage and Shortage	3-2	4.21 Installation Check	4-8
3.4 Rigging	3-3	<b>5 COMMISSIONING</b>	<b>5-1</b>
		5.1 Preparation	5-1
		5.2 First Time Start-up	5-2

<b>6 OPERATION</b>	<b>6-1</b>	<b>9 TECHNICAL DATA</b>	<b>9-1</b>
6.1 Oil Heater Operation	6-1	9.1 Dimensions	9-1
6.2 Checking the Oil Level in the Oil Reservoir	6-1	9.2 Dimensions - Evaporator Compact Water Boxes	9-4
6.3 Start-up Procedure	6-1	9.3 Nozzle Arrangements - Evaporator Compact Water Boxes	9-5
6.4 Chiller Operation	6-4	9.4 Dimensions - Condenser Compact Water Boxes	9-7
6.5 Operating Log Sheet	6-4	9.5 Nozzle Arrangements - Condenser Compact Water Boxes	9-8
6.7 Stopping the System	6-7	9.6 Dimensions - Evaporator Marine Water Boxes	9-9
6.8 Prolonged Shutdown	6-7	9.8 Nozzle Arrangements - Evaporator Marine Water Boxes	9-10
6.9 Start-up after Prolonged Shutdown	6-7	9.8 Dimensions - Condenser Marine Water Boxes	9-11
<b>7 MAINTENANCE</b>	<b>7-1</b>	9.8 Nozzle Arrangements - Condenser Marine Water Boxes	9-12
7.1 Inspections	7-1	9.9 Unit Weights	9-13
7.2 Oil Return System	7-2	9.10 Process and Instrumentation Diagram	9-15
7.3 Oil Charge	7-3	<b>10 SPARE PARTS</b>	<b>10-1</b>
7.4 Refrigerant Charge	7-3	<b>11 DE-COMMISSIONING, DISMANTLING AND DISPOSAL</b>	<b>11-1</b>
7.5 Condenser and Evaporator	7-5	11.1 General	11-1
7.6 Compressor	7-7		
7.7 Compressor Motor	7-7		
7.8 Electrical Controls	7-8		
7.9 Testing Motor Winding Insulation	7-8		
<b>8 TROUBLESHOOTING</b>	<b>8-1</b>		

# 1 SUPPLIER INFORMATION

## 1.1 Introduction

York YK chillers are manufactured to the highest design and construction standards to ensure high performance, reliability and adaptability to all types of air conditioning installations.

The units are intended for cooling water or glycol solutions and are not suitable for purposes other than those specified in this manual.

This manual and the Control System Operating Instructions contain all the information required for correct installation and commissioning of the unit, together with operating and maintenance instructions. The manuals should be read thoroughly before attempting to operate or service the unit.

All procedures detailed in the manuals, including installation, commissioning and maintenance tasks must only be performed by suitably trained and qualified personnel.

The manufacturer will not be liable for any injury or damage caused by incorrect installation, commissioning, operation or maintenance resulting from a failure to follow the procedures and instructions detailed in the manuals.

## 1.2 Warranty

York International warrants all equipment and materials against defects in workmanship and materials for one year from initial start-up, or eighteen months from delivery (whichever occurs first) unless extended warranty has been agreed as part of the contract.

The warranty is limited to free replacement and shipping of any faulty part, or sub-assembly which has failed due to poor quality or manufacturing errors. All claims must be supported by evidence that the failure has occurred within the warranty period, and that the unit has been operated within the designed parameters specified.

All warranty claims must specify the unit model, serial number and order number.

The unit warranty will be void if any modification to the unit is carried out without prior written approval from York International.

For warranty purposes, the following conditions must be satisfied:

The initial start of the unit must be carried out by trained personnel from an Authorised York Service Centre.

Only genuine York approved spare parts, oils and refrigerants must be used.

All the scheduled maintenance operations detailed in this manual must be performed at the specified times by suitably trained and qualified personnel.

Failure to satisfy any of these conditions will automatically void the warranty.

## 1.3 Safety

### Standards for Safety

YK chillers are designed and built within an EN ISO 9001 accredited design and manufacturing organisation and, within the limits specified in this manual, are in conformity with the essential health and safety requirements of the following European Union Directives:

Machinery Directive (98/37/EEC)

Low Voltage Directive (2006/95/EC)

EMC Directive (2004/108/EC)

Pressure Equipment Directive (97/23/EEC)

## 1.4 Responsibility for Safety

Every care has been taken in the design and manufacture of the units to ensure that they meet the safety requirements listed in the previous paragraph. However, the individual operating or working on any machinery is primarily responsible for:

- Personal safety, safety of other personnel, and the machinery.
- Correct utilisation of the machinery in accordance with the procedures detailed in the manuals.

The owner must comply with the Governmental Standards and Regulations for the commissioning and in-service inspections of the unit, in particular those relating to pressure equipments.

## 1.5 About this Manual

The following symbols are used in this document to alert the reader to areas of potential hazard.



**A Warning is given in this document to identify a hazard which could lead to personal injury. Usually an instruction will be given, together with a brief explanation and the possible result of ignoring the instruction.**



**A Caution identifies a hazard which could lead to damage to the machine, damage to other equipment and/or environmental pollution. Usually an instruction will be given, together with a brief explanation and the possible result of ignoring the instruction.**



**A Note is used to highlight additional information which may be helpful to you but where there are no special safety implications.**

The contents of this manual include suggested best working practices and procedures. These are issued for guidance only, they do not take precedence over the above stated individual responsibility and/or local safety regulations.

This manual and any other document supplied with the unit, are the property of York which reserves all rights. They may not be reproduced, in whole or in part, without prior written authorisation from an Authorised York representative.

## 1.6 Misuse of Equipment

### Suitability for Application

The unit is intended for cooling water or glycol solutions and is not suitable for purposes other than those specified in these instructions. Any use of the equipment other than its intended use, or operation of the equipment contrary to the relevant procedures may result in injury to the operator, or damage to the equipment.

The unit must not be operated outside the design limits specified in this manual.

### Structural Support

Structural support of the unit must be provided as indicated in these instructions. Failure to provide proper support may result in injury to the operator, or damage to the equipment.

## Mechanical Strength

The unit is not designed to withstand loads or stresses from adjacent equipment, pipework or structures. Additional components must not be mounted on the unit. Any such extraneous loads may cause structural failure and may result in injury to the operator, or damage to the equipment.

## General Access

There are a number of areas and features which may be a hazard and potentially cause injury when working with the unit unless suitable safety precautions are taken. It is important to ensure access to the unit is restricted to suitably qualified persons who are familiar with the potential hazards and precautions necessary for safe operation and maintenance of equipment containing high temperatures, pressures and voltages.

## Pressure Systems

The unit contains refrigerant vapour and liquid under pressure, release of which can be a danger and cause injury. The user should ensure that care is taken during installation, operation and maintenance to avoid damage to the pressure system. No attempt should be made to gain access to the component parts of the pressure system other than by suitably trained and qualified personnel.

## Electrical

The unit must be earthed. No installation or maintenance work should be attempted on electrical equipment without first switching off, isolating and locking-off the power supplies. Work on live equipment must only be carried-out by suitably trained and qualified personnel. No attempt should be made to gain access to inside of the control panel, wiring or other electrical enclosures during normal operation of the unit.

## Rotating Parts

Motor air vent guards and drive coupling guards must be fitted at all times and not removed unless the main power supply has been isolated.

## Refrigerants and Oils

Refrigerants and oils used in the unit are generally non-toxic, non-flammable and non-corrosive, and pose no special safety hazards. Use of gloves and safety glasses are, however, recommended when working on the unit. Build up of refrigerant vapour, from a leak for example, does pose a risk of asphyxiation in confined or enclosed spaces and attention should be given to good ventilation. For more comprehensive information on safety precautions for use of refrigerants and oils, refer to the Materials Safety Data tables provided.

## High Temperature and Pressure Cleaning

High temperature and pressure cleaning methods (e.g. steam cleaning) should not be used on any part of the pressure system as this may cause operation of the pressure relief device(s). Detergents and solvents which may cause corrosion should also be avoided.

### 1.8 Safety Labels

The following labels are fixed to each unit to give instruction, or to indicate potential hazards which may exist.



White symbol on blue background  
For safe operation, read the Instructions first



Black symbol on yellow background  
Warning: This machine may start automatically without prior warning



Black symbol on yellow background  
Warning: Hot surface



Black symbol on yellow background  
Warning: Safety relief valve may discharge gas or liquid without prior warning



Black symbol on yellow background  
Warning: Isolate all electrical sources of supply before opening or removing the cover, as lethal voltages may exist



Black symbol on yellow background  
General attention symbol

## 1.9 Material Safety Data

<b>Refrigerant Data:</b>	
<b>Safety Data</b>	<b>R134a</b>
Toxicity	Low.
In contact with skin	Liquid splashes or spray may cause freeze burns. Unlikely to be hazardous by skin absorption. Thaw affected areas with water. Remove contaminated clothing carefully — may adhere to skin in case of freeze burns. Wash affected areas with plenty of warm water. If symptoms occur (irritation or blistering) obtain medical attention.
In contact with eyes	Vapour has no effect. Liquid splashes or spray may cause freeze burns. Immediately irrigate with eyewash solution or clean water for at least 10 minutes. Obtain immediate medical attention.
Ingested	Highly unlikely to occur — but should this occur freeze burn will occur. Do not induce vomiting. Provided patient is conscious, wash mouth with water and give about 250 ml (0.5 pint) to drink. Obtain immediate medical attention.
Inhalation	High atmospheric concentrations may have an anaesthetic effect, including loss of consciousness. Very high exposures may cause an abnormal heart rhythm and prove suddenly fatal.  At higher concentration there is a danger from asphyxiation due to reduced oxygen content of atmosphere. Remove patient to fresh air, keep warm and at rest. Administer oxygen if necessary. Apply artificial respiration if breathing has ceased or shows signs of failing. In event of cardiac arrest apply external cardiac massage. Obtain immediate medical attention.
Further medical advice	Symptomatic and supportive therapy is indicated. Cardiac sensitisation has been described which may, in the presence of circulating catecholamines such as adrenalin, give rise to cardiac arrhythmia's and subsequent arrest following exposure to high concentrations.
Long term exposure	A lifetime inhalation study in rats has shown that exposure to 50,000 ppm resulted in benign tumours of the testis. This is not considered to be of relevance to humans exposed to concentrations at or below the occupational exposure limit.
Occupational exposure limits	Recommended limit: 1000 ppm v/v - 8 hr TWA.
Stability	Not specified.
Conditions to avoid	Use in presence of naked flames, red hot surfaces and high moisture levels.
Hazardous reactions	May react violently with sodium, potassium, barium and other alkali and alkaline earth metals. Incompatible materials: Magnesium and alloys containing more than 2% magnesium.
Hazardous decomposition products	Halogen acids by thermal decomposition and hydrolysis.
General precautions	Avoid inhalation of high concentrations of vapours. Atmospheric concentrations should be minimised and kept as low as reasonably practicable below the occupational exposure limit. The vapour is heavier than air and collects at low level and in confined areas. Ventilate by extraction at lowest levels.
Respiratory protection	Where doubt exists on atmospheric concentration, approved breathing apparatus should be worn. This should be self contained or of the long breather type.
Storage	Keep containers dry and in a cool place away from fire risk, direct sunlight, and all sources of heat such as radiators. Keep at temperatures not exceeding 45°C.
Protective clothing	Wear overalls, impervious gloves and goggles/face protection.



Spill/leak procedure	Ensure suitable personal protective clothing and respiratory protection is worn. Provided it is safe to do so, isolate the source of the leak. Allow small spillage's to evaporate provided there is suitable ventilation. Large spillage's: Ventilate area. Contain spillage's with sand, earth or any suitable absorbent material. Prevent liquid from entering drains, sewers, basements and work pits since vapour may create a suffocating atmosphere.
Disposal	Best to recover and recycle. If this is not possible, destruction is to be in an approved facility which is equipped to absorb and neutralise acids and other toxic processing products.
Fire extinguishing data	Non-flammable at atmospheric conditions.
Containers	Fire exposed containers should be kept cool with water sprays. Containers may burst if overheated.
Fire fighting protective equipment	Self contained breathing apparatus and protective clothing must be worn in fire conditions.

<b>Refrigerant Oil Data</b>	
<b>Safety Data</b>	<b>York "K" Oil</b>
Classification	Non-hazardous
In contact with skin	Minimally irritating. No first aid necessary. Exercise reasonable personal cleanliness including cleansing exposed skin areas several times daily with soap and water. Launder soiled work clothes at least weekly.
In contact with eyes	Flush eyes with eyewash solution or clean water for 15 minutes and consult a physician.
Ingested	May cause nausea and diarrhoea. Obtain immediate medical attention.
Inhalation	If oil mist is inhaled, remove to fresh air and consult a physician.
Occupational exposure limits	Not determined.
Stability	Stable but hygroscopic - store in sealed containers.
Conditions to avoid	Strong oxidisers, caustic or acid solutions, excessive heat. May degrade some paints and rubber materials.
Hazardous decomposition	Not fully, Analogous compounds evolve carbon monoxide, carbon dioxide and other unidentified fragments when burned. Burning may evolve irritating/ noxious fumes.
Respiratory protection	Use in well ventilated areas - ventilate locally.
Protective clothing	Goggles or face shield should be worn. Gloves not necessary, but recommended, especially for prolonged exposure.
Spill / Leak procedure	Wear suitable protective equipment. Especially goggles. Stop source of spill. Use absorbent materials to soak up fluid (i.e. sand, sawdust and commercially available materials).
Disposal	Incinerate the oil and all associated wastes in an approved facility in accordance with local laws and regulations governing oily wastes.
Fire extinguishing data	Flash point over 300°C. Use dry chemical, carbon dioxide or foam. Spraying water on hot or burning liquid may cause frothing or splashing. If a leak or spill has not ignited use water spray to disperse the vapours and to provided protection for persons attempting to stop the leak.
Containers	Fire exposed containers should be kept cool with water sprays.
Fire fighting protective equipment	Self contained breathing apparatus should be worn in fire conditions.

<b>Thermal &amp; Acoustic Materials Data</b>	
Health Hazard & First Aid	Toxicity Index <10 to NES713 Issue 3 (1991): Non-hazardous, non-toxic. No first aid necessary.
Stability / Reactivity	Stable.
Handling / Use / Disposal	No special handling precautions required. Dispose of according to local laws and regulations governing non-biodegradable non-hazardous solid wastes.
Fire & Explosion	Flammability rating Class 1 to BS 476 pt 7: Non-flammable. If forced to burn, combustion products are typically over 95% carbon dioxide and carbon monoxide.

## 2 PRODUCT DESCRIPTION

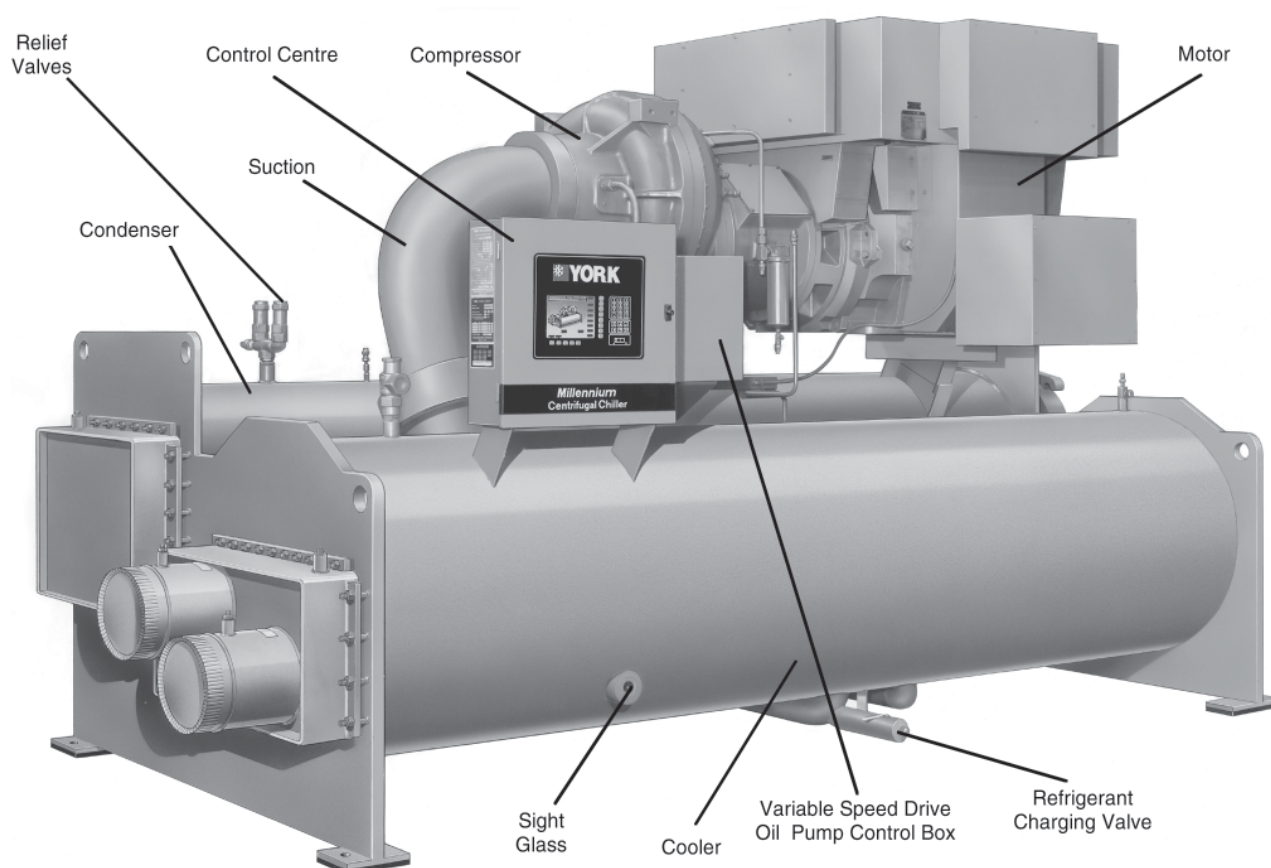

**Figure 2.1 YK Centrifugal Liquid Chiller (Front View)**

### 2.1 General (Figures 2.1 and 2.2)

The York YK Millennium™ Centrifugal Liquid Chiller is primarily used for large air conditioning systems, but may be used on other applications. The chiller is completely factory-packaged including evaporator, condenser, compressor, motor, lubrication system, graphic control centre (OptiView), and all interconnecting unit piping and wiring. The initial charge of refrigerant and oil is supplied for each unit.

The chiller is controlled by a modern state of the art microprocessor control centre that monitors its operation. The control centre is programmed by the operator to suit job specifications. Automatic timed start-ups and shut-downs are also programmable to suit nighttime, weekends, and holidays. The operating status, temperatures, pressures, and other information pertinent to operation of the chiller are automatically displayed and read on a graphic display. Other displays can be observed by pressing the keys as labelled on the control centre. The chiller with the graphic control centre (OptiView) is compatible with an electro-mechanical starter, YORK Solid State Starter (optional), or Variable Speed Drive (optional).

In operation, a liquid (water or brine to be chilled) flows through the evaporator, where boiling refrigerant absorbs heat from the liquid. The chilled liquid is then piped to fan coil units or other air conditioning terminal units, where it flows through finned coils, absorbing heat from the air. The warmed liquid is then returned to the chiller to complete the chilled liquid circuit.

The refrigerant vapour, which is produced by the boiling action in the evaporator, flows to the compressor where the rotating impeller increases its pressure and temperature and discharges it into the condenser. Water flowing through the condenser tubes absorbs heat from the refrigerant vapour, causing it to condense. The condenser water is supplied to the chiller from an external source, usually a cooling tower. The condensed refrigerant drains from the condenser into the liquid return line, where the variable orifice meters the flow of liquid refrigerant to the evaporator to complete the refrigerant circuit.

The major components of a chiller are selected to handle the refrigerant, which would be evaporated at full load design conditions. However, most systems will be called upon to deliver full load capacity for only a relatively small part of the time the unit is in operation.

### 2.2 Capacity Control (Figure 2.2)

The major components of a chiller are selected for full load capacities, therefore capacity must be controlled to maintain a constant chilled liquid temperature leaving the evaporator. Prerotated vanes (PRV), located at the entrance to the compressor impeller, compensate for variation in load (See Detail A).

The position of these vanes is automatically controlled through a lever arm attached to an electric motor located outside the compressor housing. The automatic adjustment of the vane position in effect provides the performance of many different compressors to match various load conditions from full load with vanes wide open to minimum load with vanes completely closed.

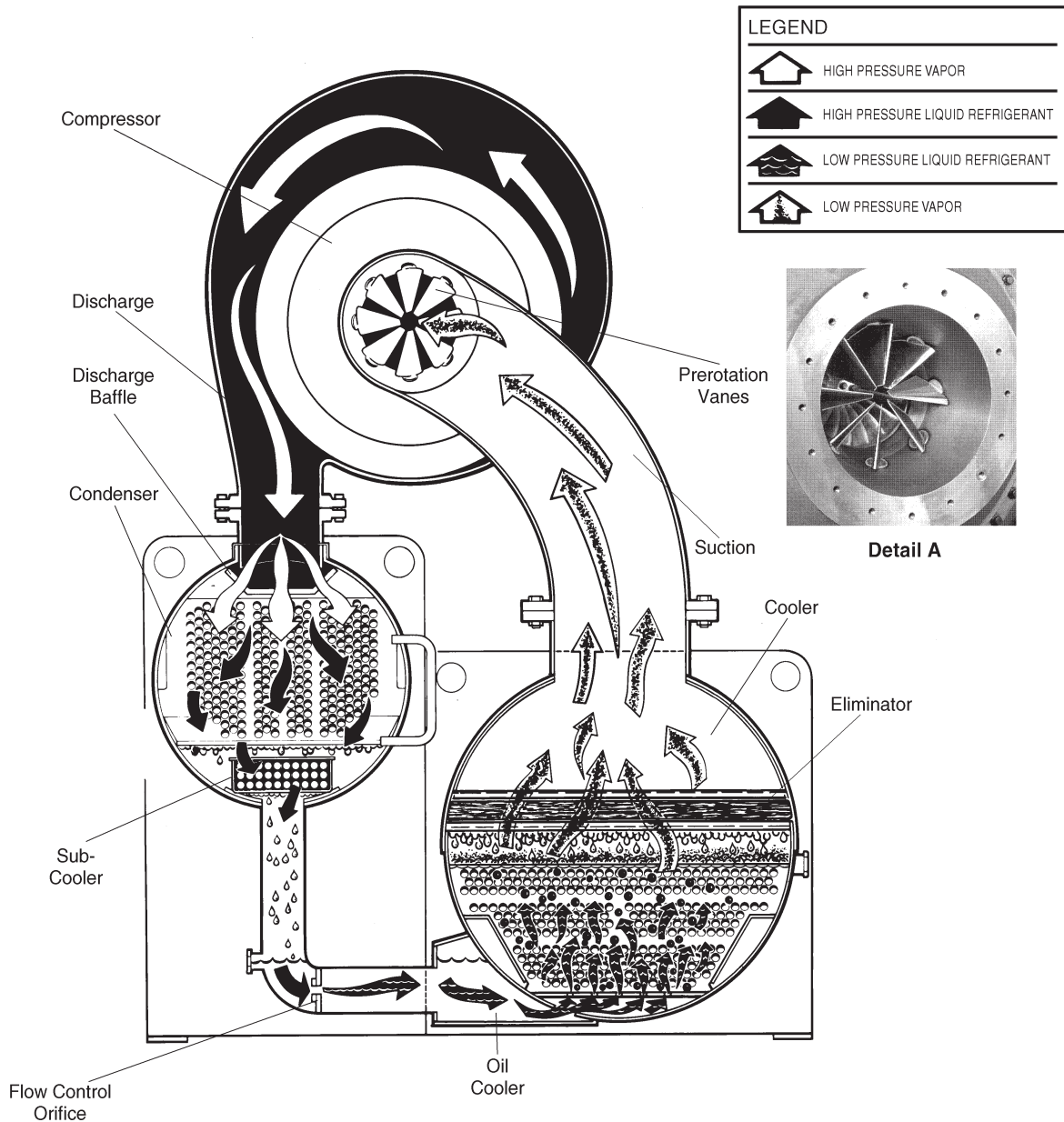
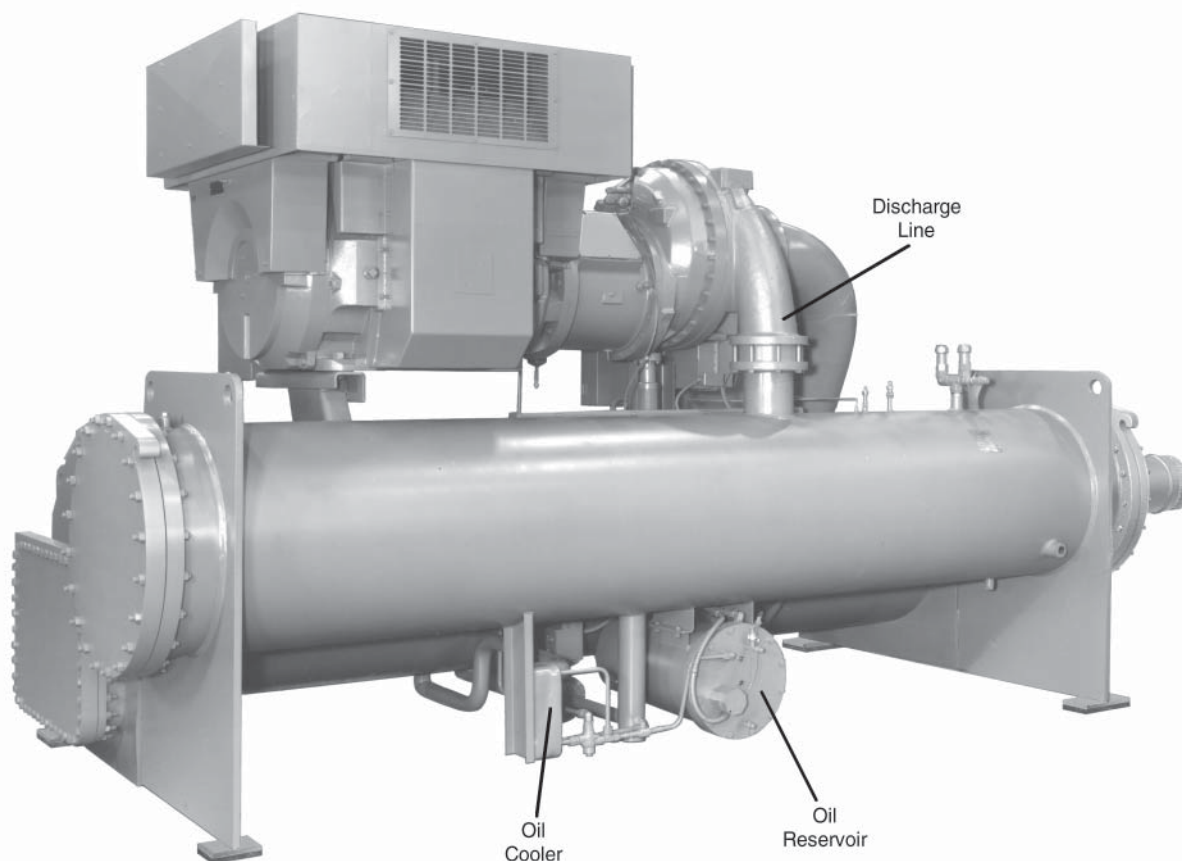

Figure 2.2 YK Refrigerant Flow Diagram



**Figure 2.3 YK Centrifugal Liquid Chiller (Rear View)**

## 2.3 Compressor

The compressor is a single-stage centrifugal type powered by an open-drive electric motor.

The rotor assembly consists of a heat-treated alloy steel drive shaft and impeller shaft with a cast aluminum, fully shrouded impeller. The impeller is designed for balanced thrust and is dynamically balanced and over-speed tested.

The inserted type journal and thrust bearings are fabricated of aluminum alloy. Single helical gears with crowned teeth are designed so that more than one tooth is in contact at all times. Gears are integrally assembled in the compressor rotor support and are film lubricated. Each gear is individually mounted in its own journal and thrust bearings.

The open-drive compressor shaft seal is a double bellows cartridge style with ceramic internal and atmospheric seal faces. The seal is oil-flooded at all times and is pressure-lubricated during operation.

## 2.4 Compressor Lubrication System (Figure 2.4)

The chiller lubrication system consists of the oil pump, oil filter, oil cooler and all interconnecting oil piping and passages. The main points within the compressor which must be supplied with forced lubrication:

1. Compressor Drive Shaft (Low Speed)
  - a. Shaft seal.
  - b. Front and rear journal bearings – one on each side of driving gear.
  - c. Low speed thrust bearing (forward and reverse).
2. Compressor Driven Shaft (High Speed)
  - a. Forward and reverse high speed thrust bearing.
  - b. Two journal bearings.
3. Speed Increasing Gears
  - a. Meshing surfaces of drive and pinion gear teeth.

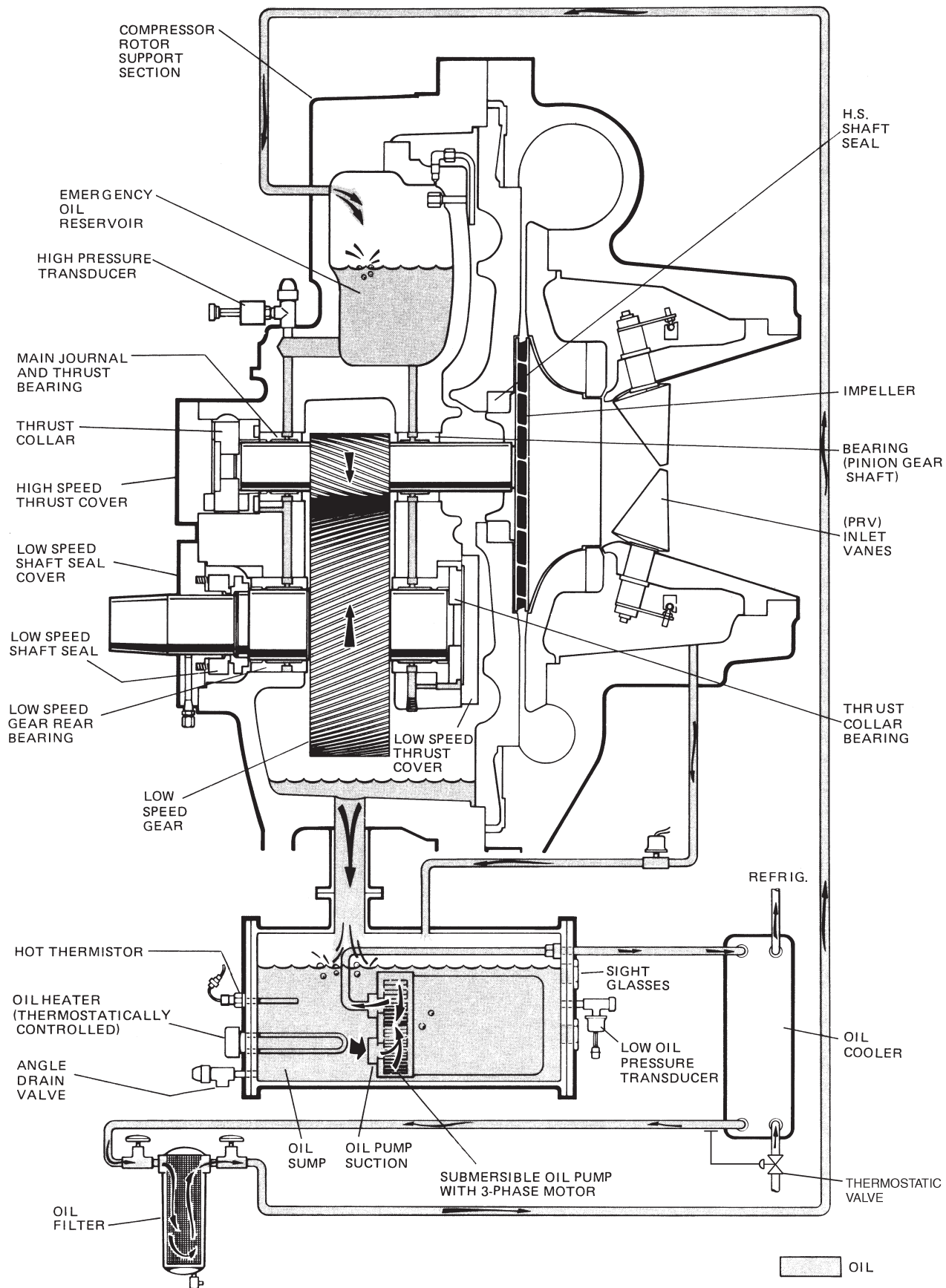

Figure 2.4 Compressor Lubrication System

To provide the required amount of oil under the necessary pressure to properly lubricate these parts, a motor driven submersible oil pump is located in a remote oil sump.

Upon pressing of the COMPRESSOR START switch on the control panel, the oil pump is immediately energized. After a 50 second pre-lube period, the compressor motor will start. The oil pump will continue to run during the entire operation of the compressor, and for 150 seconds during compressor shutdown.

The submerged oil pump takes suction from the surrounding oil and discharges it to the oil cooler where heat is rejected. The oil flows from the oil cooler to the oil filter. The oil leaves the filter and flows to the emergency oil reservoir where it is distributed to the compressor bearings. The oil lubricates the compressor rotating components and is returned to the oil sump.

There is an emergency oil reservoir located at the highest point in the lubrication system internally in the compressor. It provides an oil supply to the various bearings and gears in the event of a system shutdown due to power failure. The reservoir, located on the top of the compressor, allows the oil to be distributed through the passages by gravity flow, thus providing necessary lubrication during the compressor shutdown.

#### 2.4.1 Oil Pump

For normal operation, the oil pump should operate at all times during chiller operation.

On shutdown of the system for any reason, the oil pump operates and continues to run for 150 seconds. The system cannot restart during that time interval.

#### 2.4.2 Oil Heater

During long idle periods, the oil in the compressor oil reservoir tends to absorb as much refrigerant as it can hold, depending upon the temperature of the oil and the pressure in the reservoir. As the oil temperature is lowered, the amount of refrigerant absorbed will be increased. If the quantity of refrigerant in the oil becomes excessive, violent oil foaming will result as the pressure within the system is lowered on starting. This foaming is caused by refrigerant boiling out of the oil as the pressure is lowered. If this foam reaches the oil pump suction, the bearing oil pressure will fluctuate with possible temporary loss of lubrication, causing the oil pressure safety cutout to actuate and stop the system (Refer to Control Centre Manual 160.54.OI).

### 2.5 Compressor Motor

The compressor motor is an open-drip-proof, squirrel cage, induction type constructed to York design specifications, 50 hertz motors operate at 2975 rpm.

The open motor is provided with a D-flange, cast iron adapter mounted to the compressor and supported by

a motor support.

Motor drive shaft is directly connected to the compressor shaft with a flexible disc coupling. This coupling has all metal construction with no wearing parts to assure long life, and no lubrication requirements to provide low maintenance.

For units utilising remote electro-mechanical starters, a terminal box is provided for field connected conduit. Motor terminals are brought through the motor casing into the terminal box. Jumpers are furnished for three-lead type of starting. Motor terminal lugs are not furnished. Overload/overcurrent transformers are furnished with all units.

For units furnished with factory packaged Solid State Starters, (optional) see Options Section.

### 2.6 Graphic Control Centre (OptiView)

The graphic control centre is factory-mounted, wired and tested. The electronic panel automatically controls the operation of the unit in meeting system cooling requirements while minimizing energy usage. For detailed information on the Graphic Control Centre, refer to Form 160.54-O1

### 2.7 Heat Exchangers

Evaporator and condenser shells are fabricated from rolled carbon steel plates with fusion welded seams. Heat exchanger tubes are internally enhanced type.

#### 2.7.1 Evaporator

The evaporator is a shell and tube, flooded type heat exchanger. A distributor trough provides uniform distribution of refrigerant over the entire shell length. Stainless steel mesh eliminators or suction baffles are located above the tube bundle to prevent liquid refrigerant carryover into the compressor. A 2" liquid level sight glass is located on the side of the shell to aid in determining proper refrigerant charge. The evaporator shell contains dual refrigerant relief valves.

#### 2.7.2 Condenser

The condenser is a shell and tube type, with a discharge gas baffle to prevent direct high velocity impingement on the tubes. A separate subcooler is located in the condenser to enhance performance. Dual refrigerant relief valves are located on condenser shells with optional isolation refrigerant isolation valves.

#### 2.7.3 Water Boxes

The removable compact water boxes are fabricated of steel. The design working pressure is 1034 kPa and the boxes are tested at 1551 kPa. Integral steel water baffles provide the required pass arrangements.

Stub-out water nozzle connections with Victaulic grooves are welded to the water boxes. These nozzle connections are suitable for Victaulic couplings, welding or flanges, and are capped for shipment. Plugged  $\frac{3}{4}$ " drain and vent connections are provided in each water box.

## 2.8 Refrigerant Flow Control

Refrigerant flow to the evaporator is controlled by a variable orifice.

A level sensor senses the refrigerant level in the condenser and outputs an analog voltage to the microprocessor that represents this level (0% = empty; 100% = full). Under program control, the microprocessor modulates a variable orifice to control the condenser refrigerant level to a programmed setpoint. Other setpoints affect the control sensitivity and response. These setpoints must be entered at chiller commissioning by a qualified service technician. Only a qualified service technician may modify these settings.

While the chiller is shut down, the orifice will be in the fully open position causing the sensed level to be approximately 0%. When the chiller is started, after the vane motor end switch (VMS) opens when entering SYSTEM RUN, if actual level is less than the level setpoint, a linearly increasing ramp is applied to the level setpoint. This ramp causes the setpoint to go from the initial refrigerant level (approximately 0%) to the programmed setpoint over a period of 15 minutes.

If the actual level is greater than the setpoint when the VMS opens, there is no pulldown period, it immediately begins to control to the programmed setpoint.

While the chiller is running, the refrigerant level is normally controlled to the level setpoint. However, anytime the vanes fully close (VMS closes), normal level control is terminated, any refrigerant level setpoint pulldown in effect is cancelled and the outputs to the level control will be opposite that which is supplied to the vane motor (i.e., when a close pulse is applied to the vane motor, an open pulse is applied to the level control, etc.). When the VMS opens, if the refrigerant level is less than the level setpoint, a refrigerant level setpoint pulldown is initiated as described above. Otherwise, the level is controlled to the programmed setpoint.

## 2.9 Options and Accessories

### 2.9.1 Service Isolation Valves

If the chiller is equipped with optional service isolation valves on the discharge and liquid line, these valves must remain open during operation. These valves are used for isolating the refrigerant charge in either the evaporator or condenser to allow service access to the system. A refrigerant pump-out unit will be required to isolate the refrigerant.

Isolation of the refrigerant in this system must be performed by a qualified service technician.

### 2.9.2 Hot Gas Bypass

Hot gas bypass is optional and is used to eliminate compressor surge during light load or high head operation. The control panel will automatically modulate the hot gas valve open and closed as required. Adjustment of the hot gas control valve must be performed by a qualified service technician following the Hot Gas Set-up procedure.

Changes in chilled water flow will require re-adjustment of the hot gas control to insure proper operation.

### 2.9.3 Solid State Starter

The optional Solid State Starter is a reduced voltage starter that controls and maintains a constant current flow to the motor during start-up. It is mounted on the chiller. Power and control wiring between the starter and chiller are factory installed. Available for 380-600 volts, the starter enclosure is IP54 with a hinged access door with lock and key. Electrical lugs for incoming power wiring are provided.

### 2.9.4 Variable Speed Drive

An optional 400V – 3-Ph – 60/50Hz Variable Speed Drive can be factory packaged with the chiller. It is designed to vary the compressor motor speed and pre-rotation vane position by controlling the frequency and voltage of the electrical power to the motor. Operational information is contained in Form 160.00-O1 (VSD 658 HP and 900 HP) or 160.00-O4 (VSD OptiSpeed 292 HP and 419 HP). The control logic automatically adjusts motor speed and compressor pre-rotation vane position for maximum part load efficiency by analysing information fed to it by sensors located throughout the chiller.

The VSD eliminates the need for a starter and has a soft starting characteristic that never exceeds 100% full load amps. It also provides automatic power factor correction.

An optional harmonic filter limits electrical power supply distortion from the variable speed drive and further improves power factor correction.



## 2.10 Nomenclature

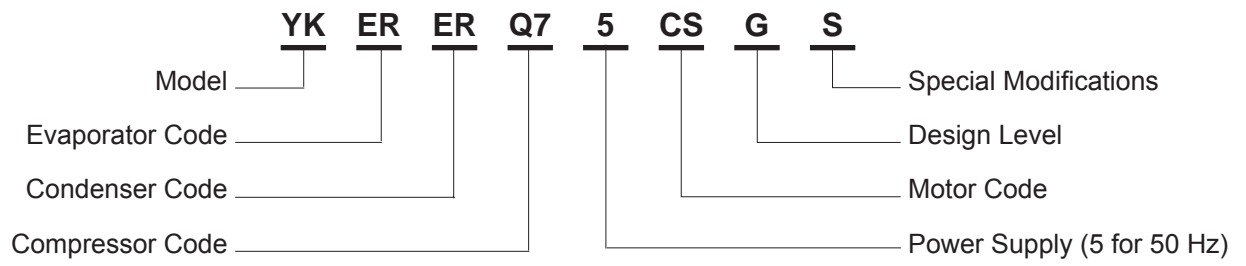

## 2.11 Range of Models

COMPRESSOR CODE	EVAPORATOR CODE	CONDENSER CODE	MOTOR CODES
Q3	AP to AS	AP to AS	5CC-5CO
Q3, Q4	CP to CS	CP to CS	
	DP to DS	DP to DS	
Q4	EP to ET	EP to ET	
Q5	CP to CS	CP to CS	5CE-5CO
	DP to DS	DP to DS	
Q5, Q6, Q7	EP to ET	EP to ET	
	FQ to FT	FQ to FT	
P7	EP to ET	EP to ET	5CP-5CU
P8	FQ to FT	FQ to FT	
	P8, P9	GQ to GS	EV to EX
HQ to HS		FV to FX	
JP to JS		JP to JS	
H9	LQ to LS	LQ to LS	
	KP to KS, K2 to K4	KP to KS, K2 to K4	5CK-5CW
MQ to MS, M2 to M4	MQ to MS, M2 to M4		
K1	KT to KX, K5 to K7	KP to KS, K2 to K4	5CN-5DC
K1, K2	MQ to MS, M2 to M4	MQ to MS, M2 to M4	
	NQ to NS, N2 to N4	NP to NS, N2 to N4	
	PQ to PS, P2 to P4	PQ to PS, P2 to P4	
	QQ to QS, Q2 to Q4	QQ to QS, Q2 to Q4	
K3	NQ to NS, N2 to N4	NP to NS, N2 to N4	5DA-5DH
	QQ to QS, Q2 to Q4	QQ to QS, Q2 to Q4	
	RQ, RS, RV, R3, R5, R7	RQ to RS, R2 to R4	
K4	RP, RR, RT, R2, R4, R6	RQ to RS, R2 to R4	
	SQ, SS, SV, S3, S5, S7	SQ to SS, S2 to S4	
		VP to VS, V2 to V5	
	XQ to XS, X2 to X4	TP to TS, T2 to T5	
K7	WP to WT, W2, W4, W6	WQ to WS, W1 to W4	5DD-5DL
		ZQ to ZS, Z1 to Z4	

### 3 TRANSPORTATION, RIGGING AND STORAGE

#### 3.1 General

YK units are shipped as a single factory assembled, piped, wired package, requiring minimum installation to make chilled water connections, condenser water connections, refrigerant atmospheric relief connections, and electrical power connections.

Refrigerant and oil charges are shipped separately (unless optional condenser isolation valves are ordered).

Chillers can also be shipped dismantled when required by rigging conditions, but generally it is more economical to enlarge access openings to accommodate the factory assembled unit. Chillers shipped dismantled **MUST** be field assembled under the supervision of a York representative.

#### FIELD ASSEMBLED UNITS ONLY

Use Form 160.73-N3 in conjunction with this manual. This instruction will be furnished with all units that are to be field assembled. Extra copies may be ordered from the York Publication Distribution Centre.

A York authorised representative must check the installation, supervise the initial start-up and operation of all newly installed chillers.



The York Warranty may be voided if the following restrictions are not adhered to:

1. No valves or connections should be opened under any circumstances because such action will result in loss of the factory nitrogen charge.
2. Do not dismantle or open the chiller for any reason except under the supervision of a York representative.
3. When units are shipped dismantled, notify the nearest York office in ample time for a York representative to supervise rigging the unit to its operating position and the assembly of components.
4. Do not make final power supply connections to the compressor motor or control centre.
5. Do not charge the compressor with oil.
6. Do not charge the unit with refrigerant.
7. Do not attempt to start the system.

8. Do not run hot water (40°C maximum.) or steam through the evaporator or condenser at any time.

#### 3.2 Shipment

The chiller may be ordered and shipped in any of the following forms:

**Form 1 – Factory Assembled Unit** (complete with motor, refrigerant and oil charges)

1. The motor/compressor assembly mounted, with all necessary interconnecting piping assembled. Graphic control centre (OptiView) is mounted on the unit. Complete unit factory leak tested, evacuated and charged with R134a.

An optional Solid State Starter or Variable Speed Drive can be factory mounted and wired.

2. Miscellaneous material – Four (4) vibration isolation pads (or optional spring isolators and brackets).

**Form 2 – Factory Assembled Unit** (complete with motor, refrigerant and oil charges shipped separately).

1. The motor/compressor assembly mounted, with all necessary interconnecting piping assembled. Graphic control centre (OptiView) is mounted on the unit. Complete unit factory leak tested, evacuated and charged with holding charge of nitrogen.

An optional Solid State Starter or Variable Speed Drive can be factory mounted and wired.

2. Miscellaneous material – Four (4) vibration isolation pads (or optional spring isolators and brackets).

#### Form 3 – Driveline Separate From Shells

Shipped as three major assemblies. Unit first factory assembled, refrigerant piped, wired and leak tested; then dismantled for shipment. Compressor/motor assembly removed from shells and skidded. Evaporator/condenser shells are not skidded.

All compressor wiring attached, and all conduit is left on shell. All openings on compressor, oil separator, and shell are closed and charged with dry nitrogen (1.4 to 2 kPag).

Miscellaneous packaging of control centre, tubing, water temperature controls, wiring, oil, isolators, solid state starter (option), etc.; refrigerant charge shipped separately.



Units shipped dismantled **MUST** be re-assembled by, or under the supervision of, a York representative. (See Form 160.73-N3)

**Form 7 – Split Shells**

Shipped as four major assemblies. Unit first factory assembled, refrigerant piped, wired and leak tested; then dismantled for shipment. Compressor/motor assembly removed from shells and skidded.

Evaporator and condenser shells are separated at tube sheets and are not skidded. Refrigerant lines between shells are flanged and capped, requiring no welding.

All compressor wiring attached. All wiring harnesses on shells are removed. All openings on compressor and shells are closed and charged with dry nitrogen (1.4 to 2 kPag).

Miscellaneous packaging of control centre, tubing, water temperature controls, wiring, oil isolators, solid state starter (option), etc.; refrigerant charge shipped separately.



Units shipped dismantled **MUST** be re-assembled by, or under the supervision of, a York representative. (See Form 160.73-N3)

When more than one chiller is ordered, the major parts of each unit will be marked to prevent mixing of assemblies. (Piping and Wiring Drawings will be furnished by York.)

**3.3 Inspection, Damage and Shortage**

The unit shipment should be checked on arrival to see that all major pieces, boxes and crates are received. Each unit should be checked before unloading, for any visible signs of damage. Any damage or signs of possible damage must be reported to the transportation company immediately for their inspection.

York will not be responsible for any damage in shipment or at job site or loss of parts.

When received at the job site all containers should be opened and contents checked against the packing list. Any material shortage should be reported to York immediately.

**Chiller Data Plate**

A unit data plate is mounted on the control panel assembly of each unit, giving unit model number; design working pressure; water passes; refrigerant charge; serial numbers; and motor power characteristics and connection diagrams.

Additional information may be found on the motor data plate. This information should be included when contacting the factory on any problem relating to the motor.

### 3.4 Rigging

The complete standard chiller is shipped without skids. (When optional skids are used it may be necessary to remove the skids so riggers skates can be used under the unit end sheets to reduce overall height.)

Each unit has four (4) lifting holes (two in each end) in the end sheets which should be used to lift the unit.

Care should be taken at all times during rigging and handling of the chiller to avoid damage to the unit and its external connections. Lift only using holes shown.



Do not lift the unit with slings around motor/compressor assembly or by means of eye bolts in the tapped holes of the compressor motor assembly. Do not turn a unit on its side for rigging. Do not rig vertically.

The rigging and operating weights and overall dimensions are given in Section 9 as a guide in determining the clearances required for rigging. (Add 150 mm to overall height for optional skidded unit.).

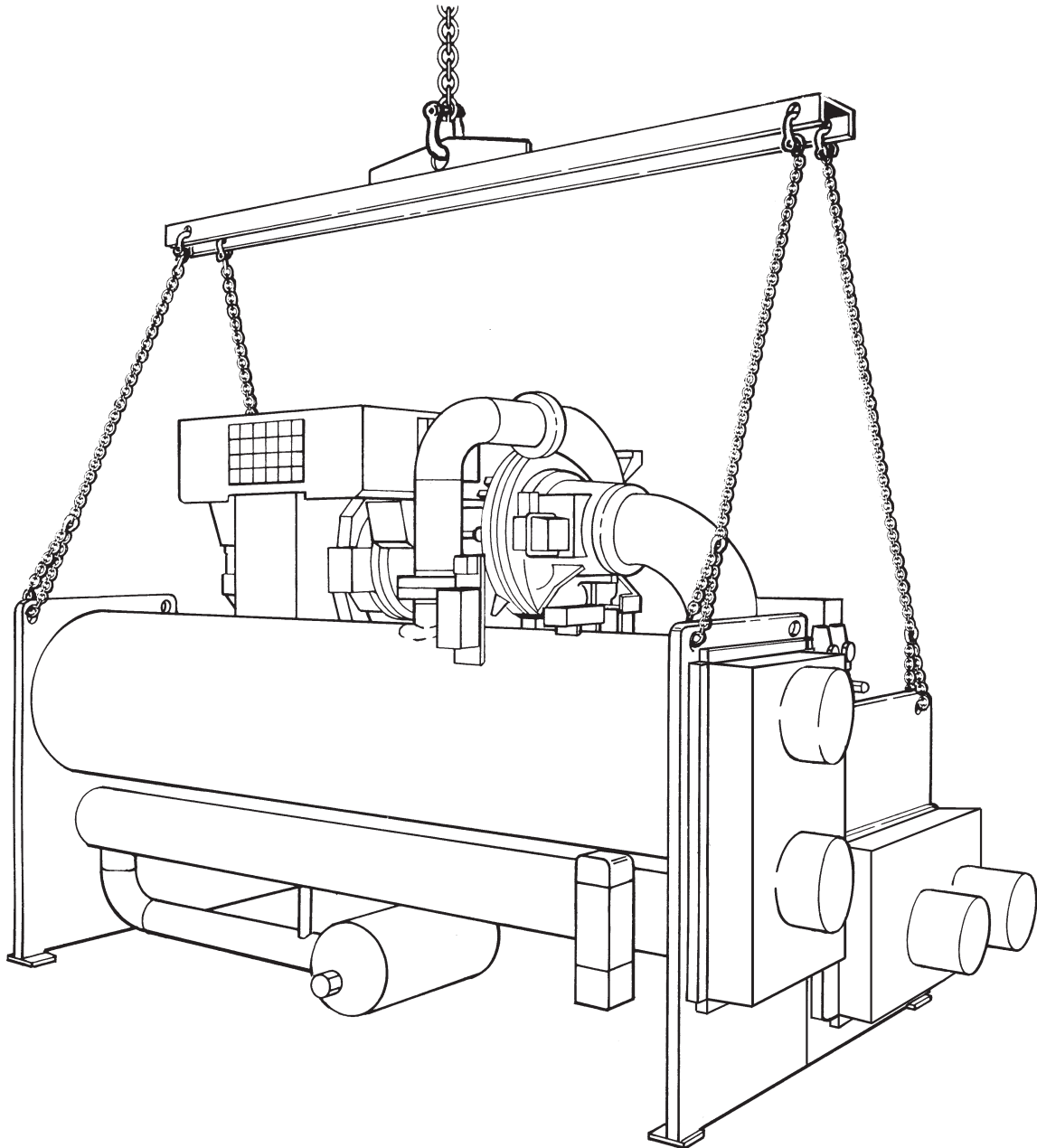

Figure 3.1 . Rigging

Page Left Intentionally Blank

## 4 INSTALLATION

### 4.1 Location

YK units are furnished with vibration isolator mounts for basement or ground level installations. Units may be located on upper floor levels providing the floor is capable of supporting the total unit operating weight and optional spring isolators are used.

Sufficient clearance to facilitate normal service and maintenance work must be provided all around and above the unit and particularly space provided at either end to permit cleaning or replacement of evaporator and condenser tubes – see Clearances.

A doorway or other sufficiently large opening properly located may be used. The chiller should be located in an indoor location where temperatures range from 4.4°C to 43.3°C.



The unit should not be installed directly on flammable materials, such as wooden structures or roof's.

### 4.2 Motors

The YK open motor is air cooled. Check national, local and other codes for ventilation requirements.

### 4.3 Foundation

A level floor, mounting pad or foundation must be provided by others, capable of supporting the operating weight of the unit.



To be in conformity with the EN 60204 standard, it can be necessary to add a service platform so that the height of the control handles (i.e. circuit breaker handle) lies between 0,6 m and 1,9 m.

### 4.4 Clearances

Clearances should be adhered to as follows:

Rear and above unit – 610 mm.

Front of unit – 910 mm.

Tube Removal– 4300 mm except those shell codes detailed below:

Evaporator Code	Condenser Code	Tube Removal (mm) (either end)
Q, N, R, X,	Q, N, R, T, X,	4900
S, Z	S, V, Z	5500
W	W	6700

### 4.5 Rigging Unit to Final Location

Rig the unit to its final location on the floor or mounting pad, lift the unit (or shell assembly) by means of an overhead lift and lower the unit to its mounting position. (If optional shipping skids are used, remove them before lowering the chiller to its mounting position.)



At this point units shipped dismantled should be assembled under the supervision of a York representative.

If evaporator is to be field insulated, the insulation should be applied to the evaporator before the unit is placed in position while the unit is in the lift position. Be sure unit is properly supported. (See INSULATION).

### 4.6 Locating and Installing Isolator Pads

The isolator pad mounts are to be located as shown in Figure .1

After the isolator pads have been placed into position on the floor, lower the chiller onto the pads. When the unit is in place, remove the rigging equipment and check that the unit is level both longitudinally and transversely. The unit should be level within 6 mm from one end to the other end and from front to the rear. If the chiller is not level within the amount specified, lift it and place shims between the isolation pad and the chiller tube sheets. (Shims furnished by the installer.) Lower unit again and recheck to see that it is level.

### Checking the Isolation Pad Deflection

All isolation pads should be checked for the proper deflection while checking to see if the unit is level. Each pad should be deflected approximately 4 mm. If an isolation pad is under-deflected, shims should be placed between the unit tube sheet and the top of the pad to equally deflect all pads.

### Levelling the Unit

The longitudinal alignment of the unit should be checked by placing a level on the top centre of the evaporator shell under the compressor/motor assembly. Transverse alignment should be checked by placing a level on top of the shell end sheets at each end of the chiller.

### 4.7 Installing Optional Spring Isolators

When ordered, 4 spring type isolator assemblies will be furnished with the unit. The 4 assemblies are identical and can be placed at any of the 4 corners of the unit.

While the unit is still suspended by the rigging, the isolators should be bolted to the unit by inserting the cap screw(s) through the hole(s) in the mounting bracket into the tapped hole in the top of the isolator levelling bolt(s). Then the unit can be lowered onto the floor.

The levelling bolts should now be rotated one (1) turn at a time, in sequence, until the unit end sheets are clear of the floor by the dimension shown in Figure .2 and the unit is level. Check that the unit is level, both longitudinally and transversely (see Levelling the Unit). If the levelling bolts are not long enough to level unit due to an uneven or sloping floor or foundation, steel shims (grouted, if necessary) must be added beneath the isolator assemblies as necessary.

After the unit is levelled, wedge and shim under each corner to solidly support the unit in this position while piping connections are being made, pipe hangers adjusted and connections checked for alignment. Then the unit is filled with water and checked for leaks. The levelling bolts should now be finally adjusted until the wedges and shims can be removed. The unit should now be in correct level position, clear of the floor or foundation and without any effect from the weight of the piping.

### 4.8 Piping Connections

After the unit is levelled (and wedged in place for optional spring isolators) the piping connections may be made; chilled water, condenser water and refrigerant relief. The piping should be arranged with offsets for flexibility, and adequately supported and braced independently of the unit to avoid strain on the unit and vibration transmission. Hangers must allow for alignment of pipe. Isolators (by others) in the piping and hangers are highly desirable, and may be required by specifications, in order to effectively utilise the vibration isolation characteristics of the vibration isolation mounts of the unit.

Check for piping alignment – Upon completion of piping, a connection in each line as close to the unit as possible should be opened, by removing the flange bolts or coupling and checked for piping alignment. If any of the bolts are bound in their holes, or if the connection springs are out of alignment, the misalignment must be corrected by properly supporting the piping or by applying heat to anneal the pipe.



If the piping is annealed to relieve stress, the inside of the pipe must be cleaned of scale before it is finally bolted in place.

### 4.9 Evaporator and Condenser Water Piping

The evaporator and condenser liquid heads have nozzles which are grooved, suitable for welding 1034 kPa DWP flanges or the use of Victaulic couplings. Factory mounted flanges are optional.

The nozzles and water pass arrangements are delivered in accordance with the job requirements (see Product Drawings delivered with the job and Section 9). Standard units are designed for 1034 kPa DWP on the water side. If job requirements are for greater than 1034 kPa DWP, check the unit Data Plate before applying pressure to evaporator or condenser to determine if the chiller has provisions for the required DWP.

Inlet and outlet connections are identified by labels placed adjacent to each nozzle.



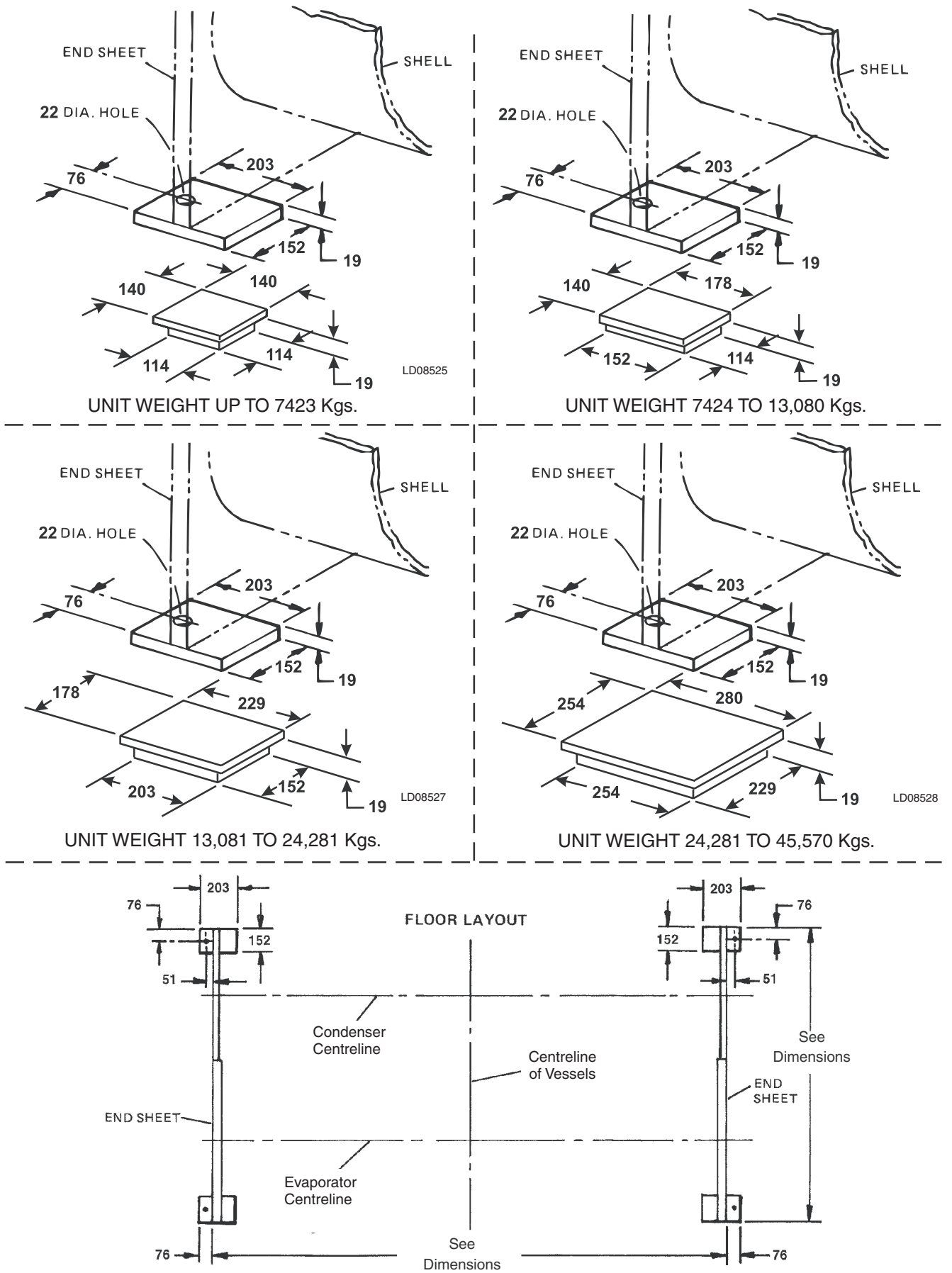
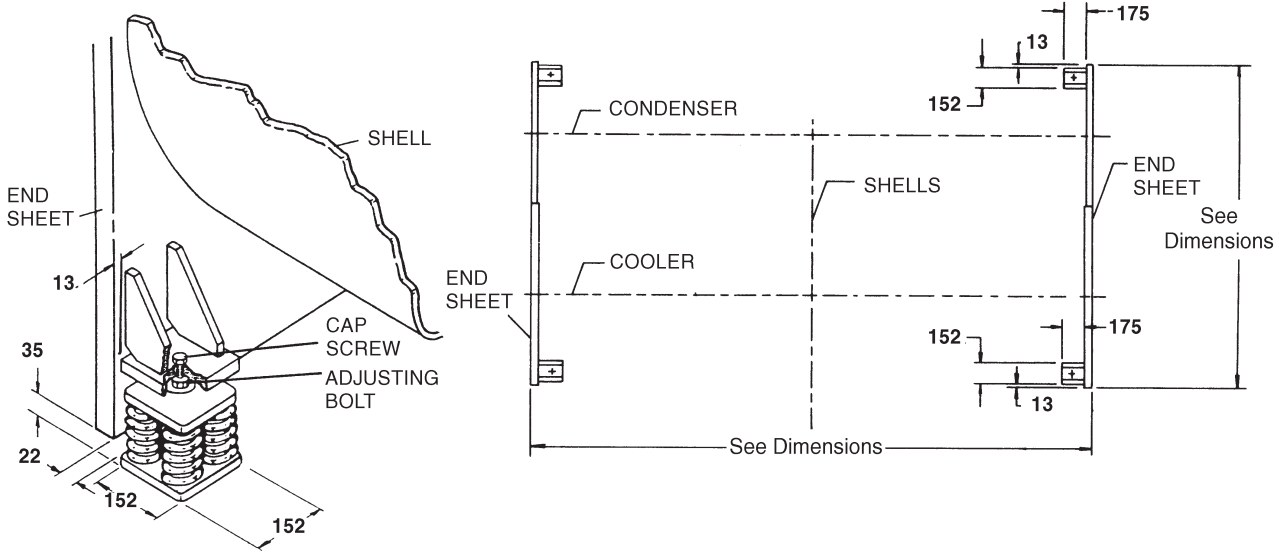
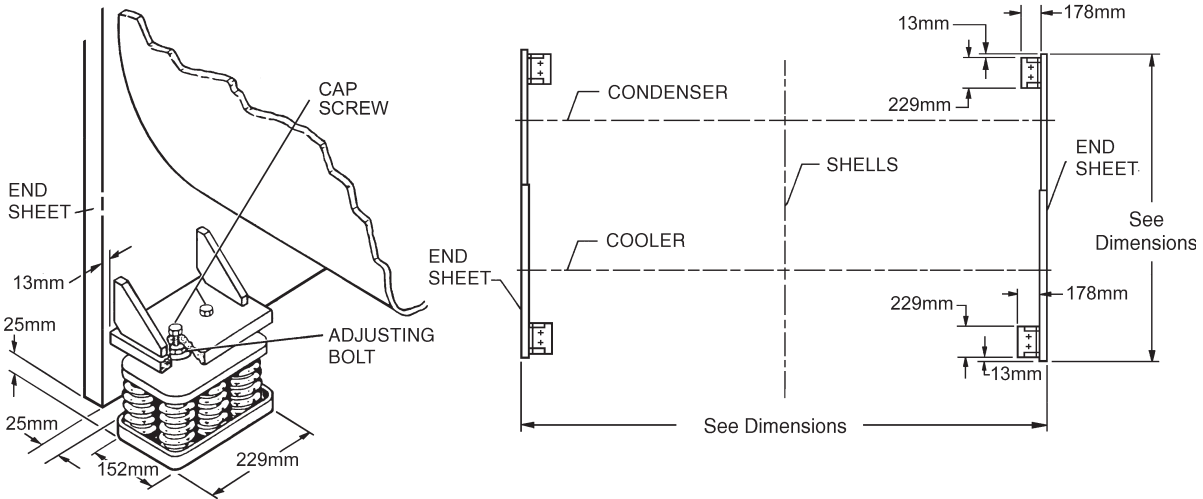

Figure 4.1 Neoprene Isolators

**4-Spring Isolators, Unit Weights less than 15880 kg**



**6-Spring Isolators, Unit Weights 15881 kg to 26467 kg**



**9-Spring Isolators, Unit Weights greater than 26468 kg**

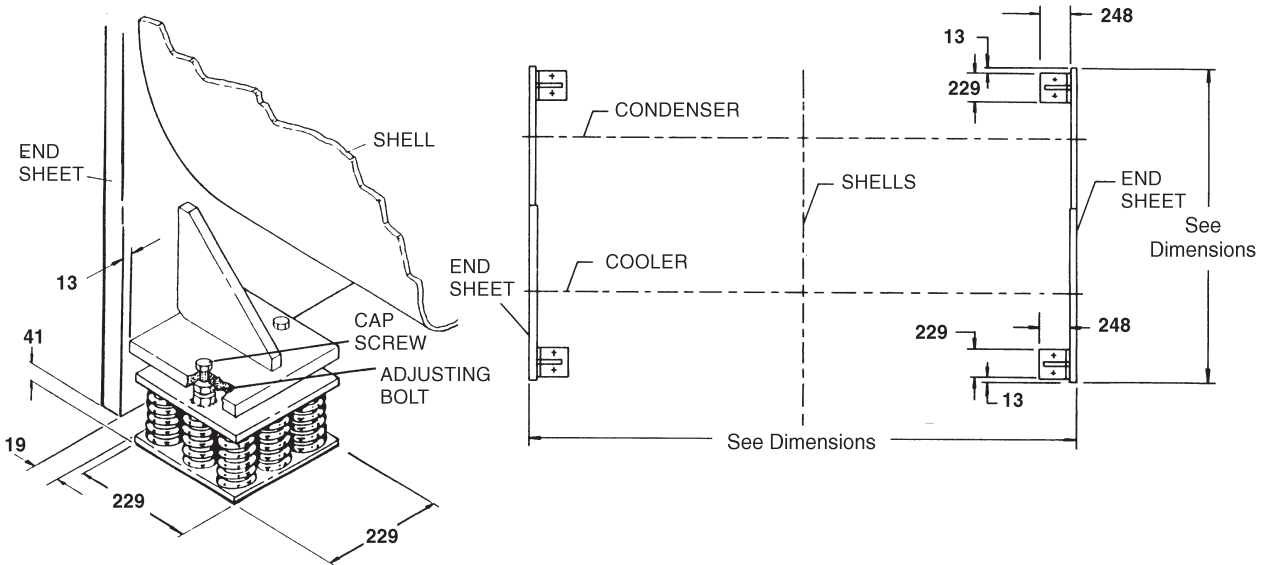

**Figure 4.2 Spring Isolators**

#### 4.9.1 Chilled Water Circuit

Foreign objects which could lodge in, or block flow through the evaporator and condenser tubes must be kept out of the water circuit. All water piping must be cleaned or flushed before being connected to the chiller pumps, or other equipment.

Permanent strainers (supplied by others) are required in both the evaporator and condenser water circuits to protect the chiller as well as the pumps, tower spray nozzles, chilled water coils and controls, etc. The strainer should be installed in the entering chilled water line, directly upstream of the chiller.

Water piping circuits should be arranged so that the pumps discharge through the chiller, and should be controlled as necessary to maintain essentially constant chilled and condenser water flows through the unit at all load conditions.

If pumps discharge through the chiller, the strainer may be located upstream from pumps to protect both pump and chiller. (Piping between strainer, pump and chiller must be very carefully cleaned before start-up.) If pumps are remotely installed from chiller, strainers should be located directly upstream of the chiller.

#### 4.9.2 Condenser Water Circuit

For proper operation of the unit, condenser refrigerant pressure must be maintained above evaporator pressure. If operating conditions will fulfill this requirement, no attempt should be made to control condenser water temperature by means of automatic valves, cycling of the cooling tower fan or other means, since chillers are designed to function satisfactorily and efficiently when condenser water is allowed to seek its own temperature level at reduced loads and off-peak seasons of the year. However, if entering condenser water temperature can go below the required minimum, condenser water temperature must be maintained equal to or slightly higher than the required minimum. Refer to Figure 4.3 for a typical water piping schematic.

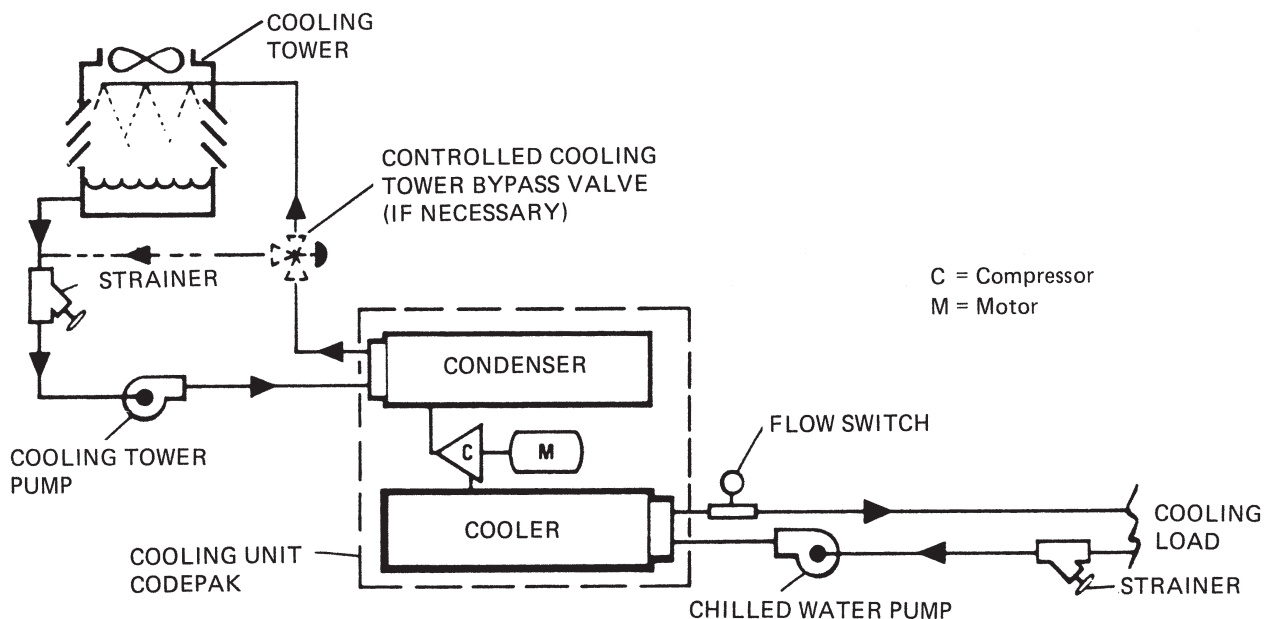

Figure 4.3 Schematic of a Typical Piping Arrangement

### 4.10 Stop Valves

Stop valves may be provided (by others) in the evaporator and condenser water piping adjacent to the unit to facilitate maintenance. Thermometer wells and pressure taps should be provided (by others) in the piping as close to the unit as possible to facilitate operating check.

### 4.11 Flow Switches (Field Installed)

A flow switch or pressure differential control in the chilled or condensed water lines is an accessory furnished for connection to the control panel. If a flow switch is used, it must be directly in series with the chiller and sensing only water flow through the chiller. The flow switch can be paddle type (field installed) or thermal type (factory mounted). A differential pressure switch that senses pressure drop across the unit can also be supplied.

### 4.12 Drain and Vent Valves

Drain and vent valves (by others) should be installed in the connections provided in the evaporator and condenser liquid heads. These connections may be piped to drain if desired.

### 4.13 Checking Piping Circuits and Venting Air

After the water piping is completed, but before any water box insulation is applied. Tighten and torque (to maintain between 41 and 82 Nm) the nuts on the liquid head flanges. Gasket shrinkage and handling during

transit may cause the nuts to loosen. If water pressure is applied before tightening is done, the gaskets may be damaged and have to be replaced.

Fill the chilled and condenser water circuits, operate the pumps manually and carefully check the evaporator and condenser water heads and piping for leaks. Repair leaks as necessary.

Before initial operation of the unit both water circuits should be thoroughly vented of all air at the high points.

### 4.14 Refrigerant Relief Piping

Each unit is equipped with pressure relief valves located on the condenser and on the evaporator for the purpose of quickly relieving excess pressure of the refrigerant charge to the atmosphere as a safety precaution in case of an emergency, such as fire. The pressure relief valve is set at design pressure of the system and has discharge capacity required by relevant standard.

Refrigerant relief vent piping (by others), from the relief valves to the outside of the building, is required by code in most areas and should be installed on all chillers. The vent line should be sized in accordance with EN13136, or local code. The vent line must include a dirt trap in the vertical leg to intercept and permit clean out and to trap any vent stack condensation. The piping MUST be arranged to avoid strain on the relief valves, using a flexible connection, if necessary.

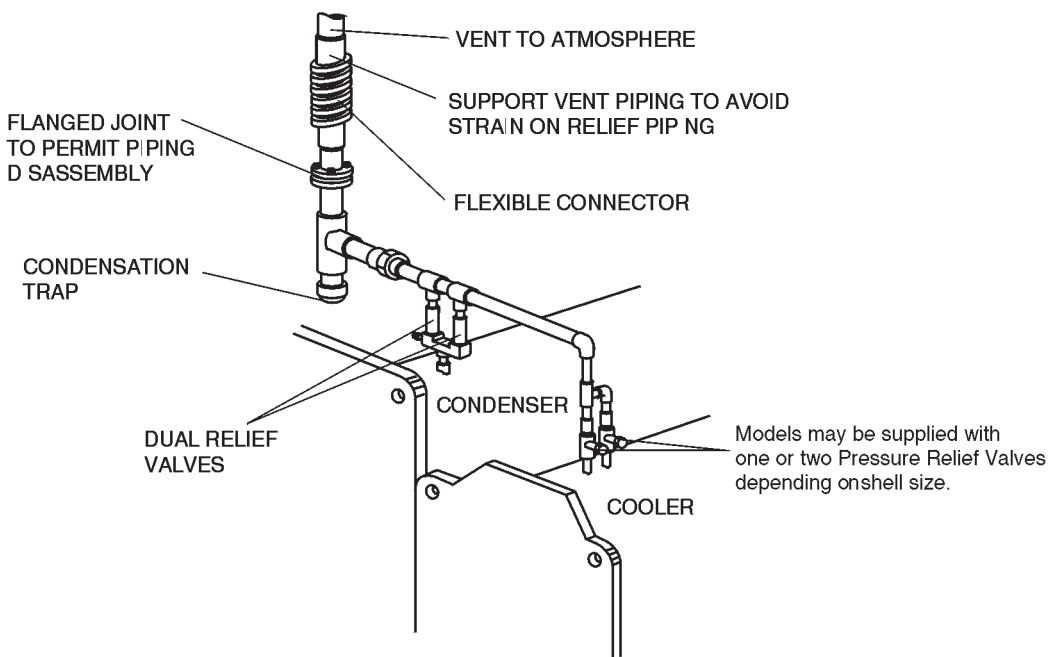

Figure 4.4 Typical Refrigerant Vent Piping

## 4.15 Unit Piping

Compressor lubricant piping and system external piping are factory installed on all units shipped assembled. On units shipped dismantled, the lubricant piping to oil sump and oil cooler and system oil return connections should be completed, under the supervision of the York representative, using material furnished. See Form 160.73-N3.

## 4.16 Control Panel Positioning (See Figure 4.5)

On units with H9 and K1-K7 compressors, the control panel is placed in a position above the evaporator for shipping. For units with P and Q compressors the control panel is **not** adjustable. To move the control panel into position for operation, proceed as follows:

1. While supporting the control panel, remove the hardware between the support arms and the evaporator.
2. Swing the control panel into a vertical position.
3. Slide the control panel down the guide rails to the proper position. Tighten securely.
4. Discard unused hardware.

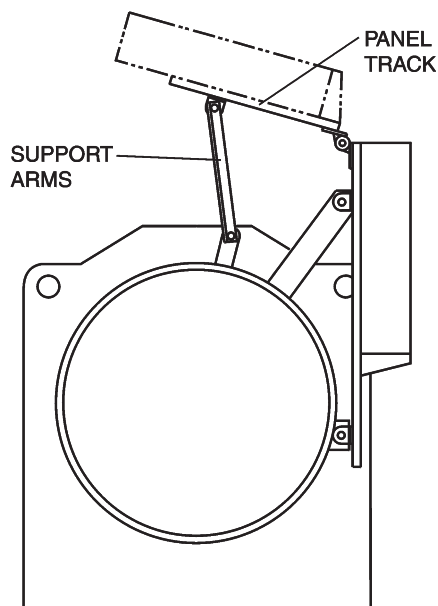

**Figure 4.5 Control Panel Positioning**

## 4.17 Control Wiring

On units shipped disassembled, after installation of the control panel, control wiring must be completed between unit components and control panel, solid state starter, or variable speed drive, when used, using wiring harness furnished. Refer to Form 160.73-N3.

Field wiring connections for control modifications (by others) if required, are shown on Form 160.73-PW7.

No deviations in unit wiring from that shown on drawings delivered shall be made without prior approval of the York representative.

## 4.18 Power Wiring

### Chiller with Electro-Mechanical Starter

A 115 V, 1 Ø, 50 Hz supply of 15 amperes must be supplied to the control panel, from the control transformer (2 kVA required) included with the compressor motor starter. **DO NOT** make final power connections to control centre until approved by York representative.

### Oil Pump – 3 Phase Starter

Separate wiring or a fused disconnect switch should be supplied by the installer.

### Remote Electro-Mechanical Starter



Remote Electro-Mechanical starters for the chiller must be furnished in accordance with York Standard R-1051 (Product Drawing Form 160.45-PA5.1) to provide the features necessary for the starter to function properly with the York control system.

Each unit is furnished for a specific electrical power supply as stamped on the Unit Data Plate, which also details the motor connection diagrams.



To insure proper motor rotation the starter power input and starter to motor connections must be checked with a phase sequence indicator in the presence of the York representative.



**DO NOT** cut wires to final length or make final connections to motor terminals or starter power input terminals until approved by the York representative.

**YK Motors (Electro-Mechanical Starter)**

Figure 4.6 shows the power wiring hook-up for Motor Connections. (Refer to Wiring Labels in Motor Terminal Box for hook-up to suit motor voltage and amperage.)

Motor leads are furnished with a crimp type connection having a clearance hole for a 3/8" bolt, motor terminal lugs are not furnished.

**4.19 Units with Solid State Starter or Variable Speed Drive**

A unit equipped with a Solid State Starter or Variable Speed Drive does not require wiring to the compressor motor. The motor power wiring is factory connected to the Solid State Starter or Variable Speed Drive (or an optional factory installed disconnect switch). See Field Wiring Diagram. All wiring to the control panel and the oil pump starter is completed by the factory. A control transformer is supplied with the Solid State Starter or Variable Speed Drive.

**4.20 Thermal Insulation**

(See Product Drawings Form 160.52-PA1)



DO NOT field insulate until the unit has been leak tested under the supervision of the York representative.

Insulation of the type specified for the job, or minimum thickness to prevent sweating of 0°C (32°F) surfaces should be furnished (by others) and applied to the evaporator shell, end sheets, liquid feed line to flow chamber, compressor suction connection, and evaporator liquid heads and connections. The liquid head flange insulation must be removable, to allow head removal for the tube maintenance. Details of areas to be insulated are given on the Product Drawing.

Units are furnished factory anti-sweat insulated on order at additional cost. This includes all low temperature surfaces except the two (2) evaporator liquid heads.

**4.21 Installation Check**

After the unit is installed, piped and wired the services of a York representative should be requested to check the installation and supervise the initial start-up and operation on all chillers.

**COMPRESSOR MOTOR FIELD CONNECTION DIAGRAM**

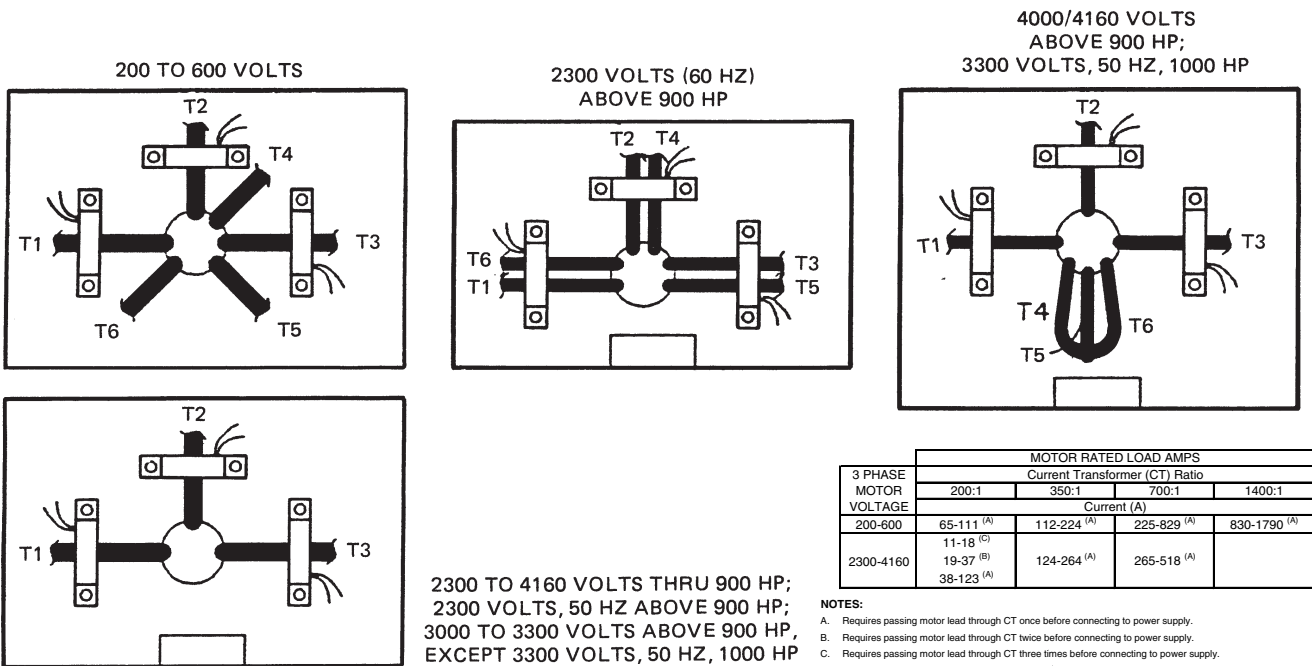

**Figure 4.6 Motor Connections (Electro-Mechanical Starter Application)**

## 5 COMMISSIONING

### 5.1 Preparation



Commissioning of this unit should only be carried out by York authorised personnel.

**The Graphic Control Centre manual must be read in conjunction with this section.**

#### Preparation - Power Off

The following checks should be made with the customer supply/supplies to the unit switched off.

**Inspection:** Inspect unit for installation damage. If found take action and/or repair as appropriate.

**Refrigerant charge:** Units are normally shipped as standard with a full refrigerant operating charge. Check that refrigerant is present and that no leaks are apparent. If no refrigerant is present a leak test must be undertaken, the leak(s) located and repaired. Repaired systems and units supplied with a nitrogen holding charge must be evacuated with a suitable vacuum pump/recovery unit as appropriate (refer to Section 7 for details).

**Oil System:** Check the oil system is correctly charged and the oil level is between the upper and lower sight glasses on the oil reservoir.

**Isolation/protection:** Verify that all sources of electrical supply to the unit are taken from a single point of isolation.

**Control panel:** Check panel to see that it is free of foreign materials (wire, metal chips, etc.) and clean out if required.

**Power connections:** Check the customer power cables are connected correctly.

**Earthing:** Verify that the units protective terminal(s) are properly connected to a suitable earthing point. Ensure that all unit internal earth connections are tight.

**Supply voltage:** Verify that the site voltage supply corresponds to the unit requirement and is within the limits given on the unit data plate.

The customers disconnection devices can now be set to ON.



The machine is now live!

**Oil Heater:** Verify the oil heater is energised for at least 12 hours prior to start-up.

**Water/Glycol system(s):** Verify that the cooling and chilled water systems have been installed correctly, and has been commissioned with the correct direction of water flow through the condenser and evaporator. Purge air from the top of the condenser and evaporator using the plugged air vents.

**Flow switch(es):** Verify a chilled water flow switch is correctly fitted in the customer's pipework on the evaporator outlet, and wired into the control panel.

**Temperature sensor(s):** Ensure the temperature sensors are coated with heat conductive compound (Part No. 013-00890-000) and inserted into the sensor pockets.

**Programmed options:** Verify that the options factory programmed into the control centre are in accordance with the customers order requirements. Refer to the Graphic Control Centre Operating Instructions for details.

**Programmed settings:** Ensure the system setpoints, cut-outs and operational settings are in accordance with the instructions given in the Graphic Control Centre Operating Instructions.

**Date & time:** Programme the date and time (see Graphic Control Centre Operating Instructions).

**Start/Stop schedule:** Programme the daily and holiday start/stop (see Graphic Control Centre Operating Instructions).

## 5.2 First Time Start-up

During the commissioning period there should be sufficient heat load to run the unit under stable full load operation to enable the unit controls, and system operation to be set up correctly and a commissioning log taken. Read the following section in conjunction with the Graphic Control Centre Operating Instructions and Section 6.

**Interlocks:** Verify that water is flowing through the evaporator and that heat load is present. Ensure that any remote run interlocks are in the run position and that the run schedule requires the unit to run or is overridden.

**Start-up:** Start the unit in accordance with Section 6 and be ready when the compressor starts to switch the unit off immediately if any unusual noises or other adverse conditions develop.

**Operation:** Check the system operating parameters are normal by selecting the various readouts of pressure, temperature, etc on the control centre.



## 6 OPERATION



If the oil heater is de-energised during a shutdown period, it must be energized for 12 hours prior to starting the compressor.

### 6.1 Oil Heater Operation

The oil heater operation is controlled by the graphic control centre (OptiView). The heater is turned on and off to maintain the oil temperature to a value 27.7 °C above the condenser saturation temperature. This is the target value and if the oil temperature falls to 2.2 °C or more below the target, the heater is turned on. It is turned off when the oil temperature increases to 1.6 °C above the target value.

If the target value is greater than 71°C, the target defaults to 71°C. If the target value is less than 43.3°C, it defaults to 43.3°C.

To prevent overheating of the oil in the event of a control centre component failure, the oil heater thermostat (1HTR) is set to open at 82°C.

### 6.2 Checking the Oil Level in the Oil Reservoir

Correct oil level - During operation, the oil level should fall to the "Operating Range" identified on the vertical oil level indicator label. (See below).

LOW OIL	OPERATING RANGE	OVER FILL
---------	-----------------	-----------

If the oil level during operation is in the "Over Full" region of the oil level indicator, oil should be removed from the oil reservoir. This reduces the oil level to the "Operating Range".

If the oil level during operation is in the "Low Oil" region of the oil level indicator, oil should be added to the oil reservoir (refer to Oil Charging Procedure, Section 7).



Comply with Local Regulations when removing or disposing of oil.

### 6.3 Start-up Procedure

#### 6.3.1 Pre-Starting

Prior to starting the chiller, observe the graphic control centre (OptiView). Make sure the display reads SYSTEM READY TO START.

To pre-start the chiller, use the following procedure:

1. Oil Heater – The oil heater must be energised for 12 hours prior to starting the chiller.
2. Prior to start, the clock must be programmed for the proper day and time. Any setpoints to be changed may be programmed. All control centre setpoints should be programmed before the chiller is started (refer to 160.54-OI for details).

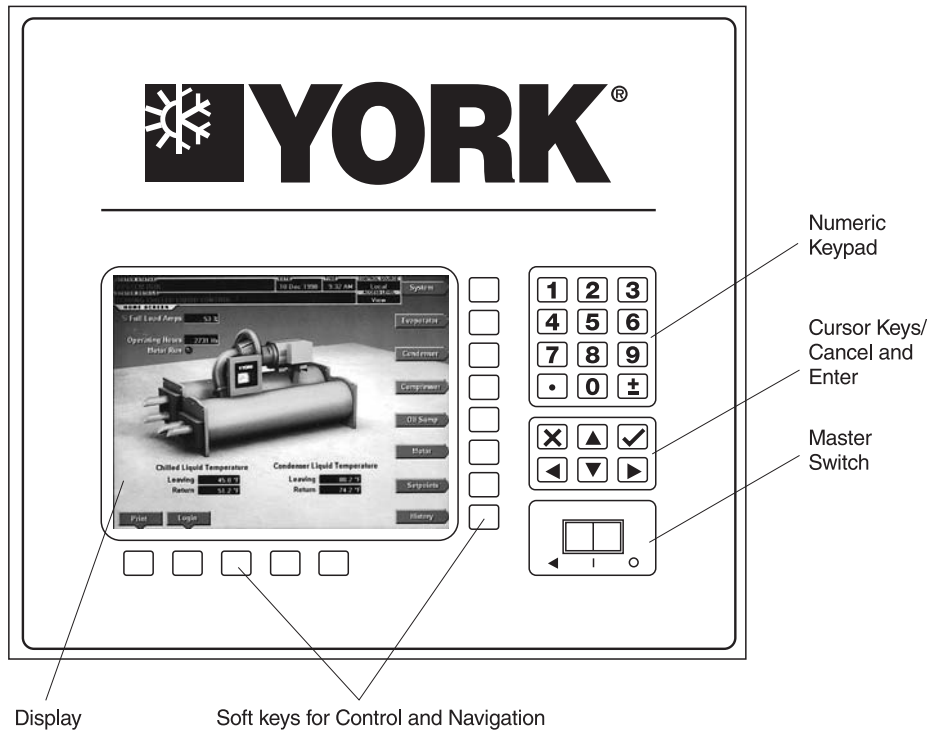

**Figure 6.1 Control Centre**

**6.3.2 Start-up**

1. If the chilled water pump is manually operated, start the pump. The control centre will not allow the chiller to start unless chilled liquid flow is established through the unit. (A field supplied chilled water flow switch is required.) If the chilled liquid pump is wired to the graphic control centre the pump will automatically start.
2. To start the chiller, press the compressor START (3) switch. This switch will automatically spring return to the RUN (1) position. When the start switch is energised, the control centre is placed in an operating mode and any fault will be shown by a display message.
3. The anti-recycle timer software function will operate after the 50 seconds of pre-run time. At this time, the timer will be initiated and will run for 30 minutes after the compressor starts. If the chiller shuts down during this period of time, it cannot be started until the timer completes the 30 minute cycle.
4. The chilled liquid pump contacts will close, starting the chilled liquid pump, to establish liquid flow through the evaporator before the compressor starts.
5. After the first 50 seconds of operation, the compressor will start.
6. For display messages and information pertaining to operation, refer to the Graphic Control Centre (OptiView )Operating Instructions (160-54-OI).

 Any faults which occur during STOP/RESET are also displayed.

 The pre-rotation vanes are closed automatically when the chiller is shut down to prevent loading the compressor on start-up.

When the chiller starts, the following automatic sequences are initiated: (Refer to Figures 6.2 and 6.3, Chiller Starting & Shutdown Sequence).

\*\* Not for all shutdowns. Refer to Graphic Control Centre Operating Instructions.

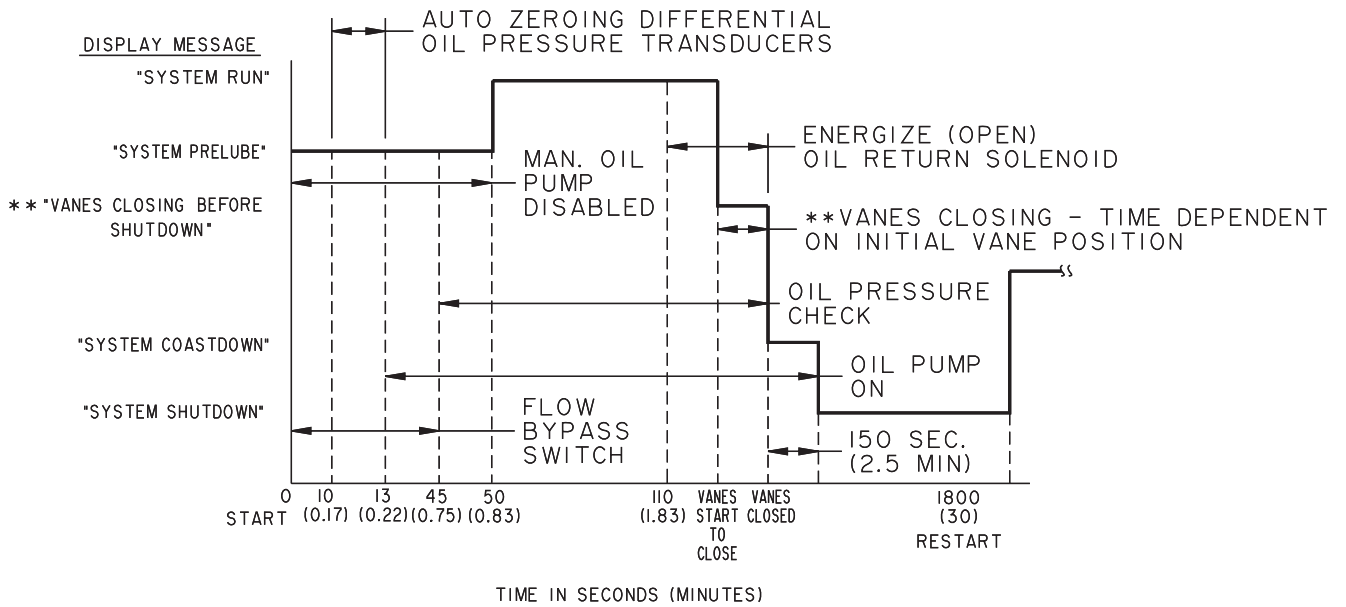

**Figure 6.2 Chiller Starting Sequence and Shutdown Sequence (Electro-mechanical and Solid State Starter Models)**

\*\* Not for all shutdowns. Refer to Graphic Control Centre Operating Instructions.

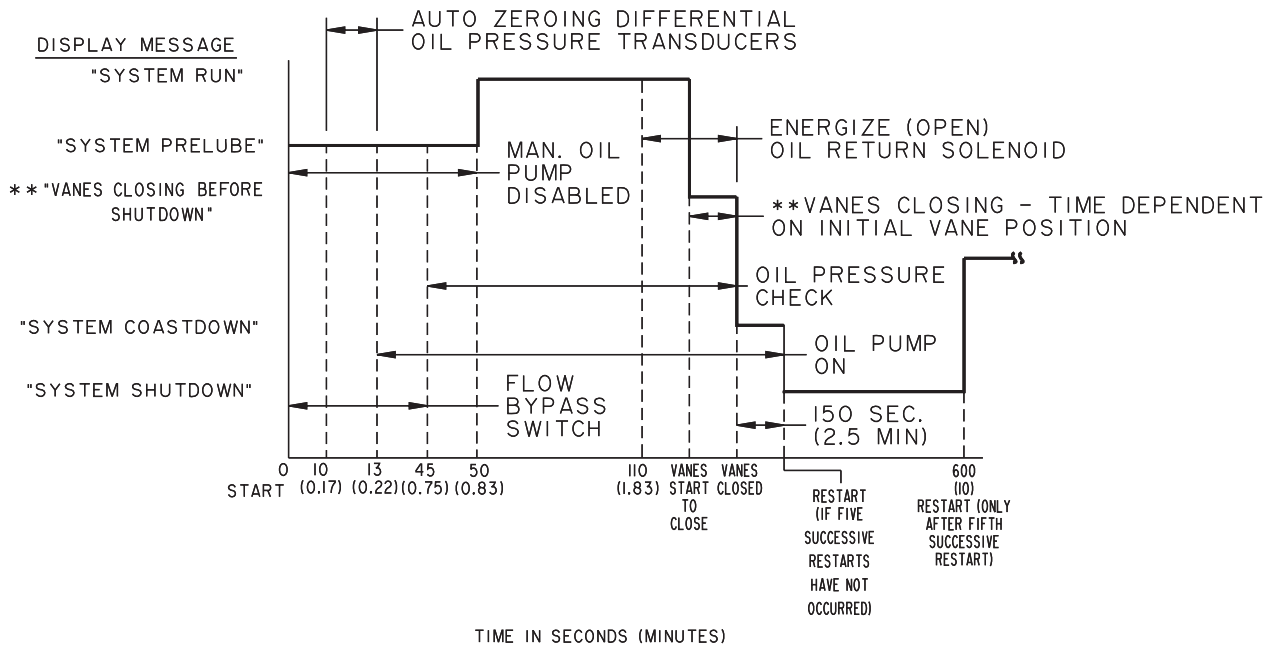

**Figure 6.2 Chiller Starting Sequence and Shutdown Sequence (Variable Speed Drive Models)**

## 6.4 Chiller Operation

After the compressor reaches operating speed, the pre-rotation vanes will begin to open under the control of the microprocessor which senses the leaving chilled liquid temperature. The unit capacity will vary to maintain the leaving CHILLED LIQUID TEMPERATURE SETPOINT. The pre-rotation vanes are modulated by an actuator under the control of the microprocessor. The vane control routine employs proportional plus derivative (rate) control action. A drop in chilled liquid temperature will cause the actuator to close the pre-rotation vanes to decrease chiller capacity. When the chilled liquid temperature rises, the actuator will open the pre-rotation vanes to increase the capacity of the chiller.

However, the current draw (A) of the compressor motor cannot exceed the setting of the % CURRENT LIMIT at any time during the unit operation. The microprocessor 40% to 100% three-phase peak current limit software function, plus the 3-phase 100% solid state overload current limiter (CM-2), on Electro-Mechanical Starter applications, or the Solid State Starter current limit function will override the temperature control function and prevent the pre-rotation vanes from opening beyond the % CURRENT LIMIT setting.

If the load continues to decrease, after the pre-rotation vanes are entirely closed, the chiller will be shut down by the Leaving Chilled Liquid – Low Temperature Control.

### 6.4.1 Condenser Water Temperature Control

The unit is designed to use less power by taking advantage of lower than design temperatures that are naturally produced by cooling towers throughout the operating year. Exact control of condenser water such as a cooling tower bypass, is not necessary for most installations. The chiller requires only that the minimum condenser water temperature be no lower than the value determined by referring to the formula below:

Where:

ECWT = Entering Condenser Water Temperature

LCWT = Leaving Chilled Water Temperature

C RANGE = Condensing Water Temperature Range at the given load condition

At start-up, the entering condenser water temperature may be as much as 14 °C colder than the return chilled water temperature. Cooling tower fan cycling will normally provide adequate control of the entering condenser water temperature on most installations.

## 6.5 Operating Log Sheet

An accurate record of system operating conditions (temperatures and pressures) recorded at regular intervals throughout each 24 hour operating period should be kept. An optional status printer is available for this purpose using automatic data logging after programming the DATA LOGGER function.

The record of readings serves as a valuable reference for operating the system. Readings taken when a system is newly installed will establish normal conditions with which to compare later readings.

For example, an increase in condenser water temperature difference (leaving condenser water temperature minus entering condenser water temperature) may be an indication of dirty condenser tubes.

## 6.6 Maintenance and Service

If the system is malfunctioning or the unit is stopped by one of the safety controls, consult Section 8. After repair or adjustment the compressor cannot be started or the particular fault continues to affect the performance of the unit, please call the nearest York Office. Failure to report constant troubles could damage the unit and increase the cost of repairs.

### 6.6.1 Normal and Safety System Shutdowns

Normal and safety system shutdowns have been built into the unit to protect it from damage during certain operating conditions. The system will be stopped automatically by controls that respond to high temperatures, low temperatures, and low and high pressures, etc.

## 6.6.2 Safety Shutdowns

If the chiller shuts down on a SAFETY shutdown, the chiller will restart when the shutdown condition is removed. These shutdowns require the operator to manually reset the graphic control centre (OptiView) prior to restarting the chiller.

### Common Shutdowns

- Evaporator – Low Pressure
- Evaporator - Low pressure - Smart freeze
- Evaporator – Transducer or Leaving Liquid Probe
- Evaporator – Transducer or Temperature Sensor
- Condenser – High Pressure Contacts Open
- Condenser – High Pressure
- Condenser – Pressure Transducer Out Of Range
- Auxiliary Safety – Contacts Closed
- Discharge – High Temperature
- Discharge – Low Temperature
- Oil – High Temperature
- Oil – Low Differential Pressure
- Oil – High Differential Pressure
- Oil – Pump Pressure Transducer Out of Range
- Oil – Sump Pressure Transducer Out of Range
- Oil – Differential Pressure Calibration
- Oil – Variable Speed Pump – Pressure Setpoint Not Achieved
- Control Panel – Power Failure
- Motor or Starter – Current Imbalance
- Thrust Bearing – Proximity Probe Clearance
- Thrust Bearing – Proximity Probe Out of Range
- Thrust Bearing - Limit Switch Open\*\*
- Watchdog – Software Reboot
- Surge protection - Excess surge

### Solid State Starter Shutdowns

- LCSSS Shutdown - Requesting Fault Data
- LCSSS - High Instantaneous Current
- LCSSS - High Phase (X) Heatsink Temperature -Running
- LCSSS - 105% Motor Current Overload
- LCSSS - Phase (X) Shorted SCR
- LCSSS - Open SCR
- LCSSS - Phase Rotation

### Variable Speed Drive Shutdowns

- VSD Shutdown – Requesting Fault Data
- VSD – 105% Motor Current Overload
- VSD – High Phase A Inverter Heatsink Temp.
- VSD – High Phase B Inverter Heatsink Temp.
- VSD – High Phase C Inverter Heatsink Temp.
- VSD – High Converter Heatsink Temperature
- VSD - High Inverter Baseplate Temperature
- VSD - High Phase A Inverter Baseplate Temperature
- VSD - High Phase B Inverter Baseplate Temperature
- VSD - High Phase C Inverter Baseplate Temperature
- VSD – Precharge Lockout
- Harmonic Filter – High Heatsink Temperature
- Harmonic Filter – High Total Demand Distortion

\* Compressors H3 and J only

\*\*Compressors P, Q, H4 thru H8 only

### 6.6.3 Cycling Shutdowns

If the chiller shuts down on a CYCLING shutdown, the chiller will automatically restart when the cycling condition is removed. These shutdowns do not require the operator to manually reset the control centre prior to restarting the chiller.

#### Common Shutdowns

- Multi-unit Cycling – Contacts Open
- System Cycling – Contacts Open
- Oil – Low Temperature Differential
- Oil – Low Temperature
- Control Panel – Power Failure
- Leaving Chilled Liquid – Low Temperature
- Leaving Chilled Liquid – Flow Switch Open
- Condenser - Flow Switch Open
- Motor Controller – Contacts Open
- Motor Controller – Loss of Current
- Power Fault
- Control Panel – Schedule
- Proximity Probe – Low Supply Voltage
- Oil – Variable Speed Pump – Drive Contacts Open

#### Solid State Starter Shutdowns

- LCSSS Initialization Failed
- LCSSS - Serial Communications
- LCSSS - Requesting Fault Data
- LCSSS - Stop Contacts Open
- LCSSS - Power Fault
- LCSSS - Low Phase (X) Temperature Sensor
- LCSSS - Run Signal
- LCSSS - Invalid Current Scale Selection
- LCSSS - Phase Locked Loop
- LCSSS - Low Supply Line Voltage
- LCSSS - High Supply Line Voltage
- LCSSS - Power Fault
- LCSSS - Logic Board Processor
- LCSSS - Logic Board Power Supply
- LCSSS - Phase Rotation / Loss
- LCSSS - Phase Loss

#### Variable Speed Drive Shutdowns

- VSD Shutdown – Requesting Fault Data
- VSD – Stop Contacts Open
- VSD Initialization Failed
- VSD – High Phase A Instantaneous Current
- VSD – High Phase B Instantaneous Current
- VSD – High Phase C Instantaneous Current

- VSD - High Converter Heatsink Temperature
- VSD – Phase A Gate Driver
- VSD – Phase B Gate Driver
- VSD – Phase C Gate Driver
- VSD – Single Phase Input Power
- VSD – High DC Bus Voltage
- VSD – Logic Board Power Supply
- VSD – Low DC Bus Voltage
- VSD – DC Bus Voltage Imbalance
- VSD – Pre-Charge DC Bus Voltage Imbalance
- VSD – High Internal Ambient Temperature
- VSD – Invalid Current Scale Selection
- VSD – Low Phase A Inverter Heatsink Temp.
- VSD – Low Phase B Inverter Heatsink Temp.
- VSD – Low Phase C Inverter Heatsink Temp.
- VSD – Low Converter Heatsink Temperature
- VSD - Low Phase A Inverter Baseplate Temperature
- VSD - Low Phase B Inverter Baseplate Temperature
- VSD - Low Phase C Inverter Baseplate Temperature
- VSD – Pre-Charge – Low DC Bus Voltage
- VSD - Low Inverter Baseplate Temperature
- VSD – Logic Board Processor
- VSD – Run Signal
- VSD – Serial Communications
- Harmonic Filter – Logic Board or Communications
- Harmonic Filter – High DC Bus Voltage
- Harmonic Filter – High Phase A Current
- Harmonic Filter – High Phase B Current
- Harmonic Filter – High Phase C Current
- Harmonic Filter – Phase Locked Loop
- Harmonic Filter – Precharge-Low DC Bus Voltage
- Harmonic Filter – Low DC Bus Voltage
- Harmonic Filter – DC Bus Voltage Imbalance
- Harmonic Filter – Input Current Overload
- Harmonic Filter – Logic Board Power Supply
- Harmonic Filter – Run Signal
- Harmonic Filter – DC Current Transformer 1
- Harmonic Filter – DC Current Transformer 2
-

## 6.7 Stopping the System

The graphic control centre (OptiView) can be programmed to start and stop automatically (maximum, once each day) whenever desired. To stop the chiller, proceed as follows:

1. Push the compressor STOP/RESET(O) switch. The compressor will stop automatically. The oil pump will continue to run for shutdown period. The oil pump will then stop automatically.
2. Stop the chilled water pump (if not wired into the graphic control centre, in which case it will shut off automatically simultaneously with the oil pump.) (The actual water pump contact operation is dependent upon the position of the microprocessor board jumper J54.)
3. Open the switch to the cooling tower fan motors, if used.
4. The compressor sump oil heater (thermostatically controlled) is energised when the unit is stopped.

## 6.8 Prolonged Shutdown

If the chiller is to be shut down for an extended period of time (for example, over the winter season), the following paragraphs detail the procedure to be followed.

1. Test all system joints for refrigerant leaks with a leak detector. If any leaks are found, they should be repaired before allowing the system to stand for a long period of time.

During long idle periods, the tightness of the system should be checked periodically.

2. If freezing temperatures are encountered while the system is idle, carefully drain the water from the cooling tower, condenser, condenser pump, and the chilled water system, chilled water pump and coils.

Open the drains on the evaporator and condenser liquid heads to assure complete drainage. (If a Variable Speed Drive is fitted, drain its water cooling system. If a Solid State Starter is fitted drain water from starter cooling loop).

3. On the SETUP Screen, disable the clock. This conserves the battery.
4. Open the main disconnect switches to the compressor motor, condenser water pump and the chilled water pump. Open the 115 V circuit to the control centre.

## 6.9 Start-up after Prolonged Shutdown

1. When putting the system into operation after prolonged shutdown (during the winter), remove all oil from the compressor. Install a new filter element and charge the compressor with fresh oil. On the SETUP Screen, enable the clock. Energise the 115 V circuit to the control centre to energise the compressor sump oil heater for at least 12 hours.
2. Operate the Oil Pump (press and release the MANUAL OIL PUMP key) until steady oil pressure is established. Then press and release the OIL PUMP key to stop operation of the oil pump. If the water systems were drained, fill the condenser water circuit and chilled liquid circuit.

Page Left Intentionally Blank



## 7 MAINTENANCE

The units have been designed to operate continuously provided they are regularly maintained and operated within the limitations given in this manual. Each unit should be included in a routine schedule of daily maintenance checks by the operator/customer, backed up by regular service inspection and maintenance visits by a suitably qualified Service Engineer.

It is entirely the responsibility of the owner to provide for these regular maintenance requirements and/or enter into a maintenance agreement with York International service organisation to protect the operation of the unit. If damage or a system failure occurs due to improper maintenance during the warranty period, York shall not be liable for costs incurred to return the unit to satisfactory condition.



This maintenance section applies to the basic unit only and may, on individual contracts, be supplemented by additional requirements to cover any modifications or ancillary equipment as applicable.



The Safety Section of this manual should be read carefully before attempting any maintenance operations on the unit. This section should be read in conjunction with the MBCS Manual.

### 7.1 Inspections

#### 7.1.1 Scheduled Maintenance

The maintenance operations detailed in the following paragraphs should be carried out on a regular basis by a suitably qualified Service Engineer. It should be noted that the interval necessary between each 'minor' and 'major' service can vary depending on, for instance, application, site conditions and expected operating schedule. Normally a 'minor' service should be carried out every three to six months and a 'major' service once a year. It is recommended that your local York Service Centre is contacted for recommendations for individual sites.

#### 7.1.2 Daily

1. Check graphic control centre (OptiView) displays.
2. If the compressor is in operation, check the bearing oil pressure on the SYSTEM Screen. Also check the oil level in the oil reservoir. Operating oil level should be between the upper and lower sight glasses. Drain or add oil if necessary.
3. Check entering and leaving condenser water pressure and temperatures are correct for design conditions on the SYSTEM Screen.

4. Check the entering and leaving chilled liquid temperatures and evaporator pressure are correct for design conditions on the SYSTEM Screen.
5. Check the condenser saturation temperature (based upon condenser pressure sensed by the condenser transducer) on the SYSTEM Screen.
6. Check the compressor discharge temperature on the SYSTEM Screen. During normal operation discharge temperature should not exceed 104 °C .
7. Check the compressor motor current on the SYSTEM Screen.
8. Check for any signs of dirty or fouled condenser tubes. (The temperature difference between condenser leaving liquid and saturated condensing temperature should not exceed the difference recorded for a new unit by more than 2.2°C).

#### 7.1.3 Weekly

1. Check the refrigerant charge (See Refrigerant Charge Checking).

#### 7.1.4 Every 3 Months

1. Perform chemical analysis of oil.
2. The unit should be leak tested. Any leaks found must be repaired immediately.

#### 7.1.5 Every 6 Months (or more often as required)

1. Change and inspect compressor oil filter element.
2. Oil return system:
  - a. Change dehydrator or earlier if the oil return system fails to operate.
  - b. Check nozzle of eductor for foreign particles.
3. Check controls and safety cutouts.

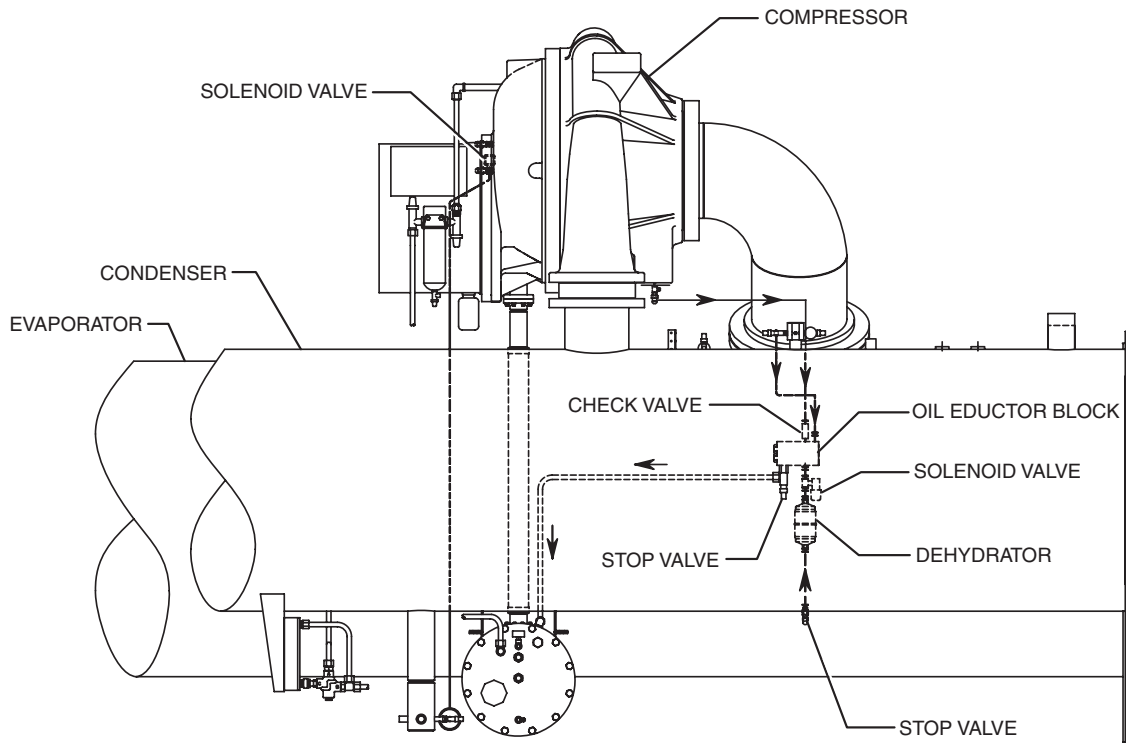

**Figure 7.1 Oil Return System**

**7.1.6 Annually (more often if necessary)**

1. Drain and replace the oil in the compressor oil sump (See Oil Charging Procedure).
2. Evaporator and Condenser:
  - a. Inspect and clean water strainers.
  - b. Inspect and clean tubes as required.
  - c. Inspect end sheets.
3. Compressor Motor (See motor manufacturers maintenance and service instruction supplied with unit):
  - a. Clean air passages and windings per manufacturers instructions.
  - b. Test winding insulation.
  - c. Lubricate ball bearings.
4. Inspect and service electrical components as necessary.
5. Perform chemical analysis of system.

**7.2 Oil Return System**

The oil return system continuously maintains the proper oil level in the compressor oil sump (Refer to Figures 2.6 and 7.1).

High pressure condenser gas flows continuously through the eductor inducing the low pressure, oil rich liquid to flow from the evaporator, through the dehydrator to the compressor sump.

**7.2.1 Changing the Dehydrator**

To change the dehydrator, use the following procedure:

1. Shut the stop valves on the condenser gas line, oil return line to rotor support and inlet end of the dehydrator.
2. Remove the dehydrator, refer to figure 7.1.
3. The nozzle of the eductor should be checked for any foreign particles that may be obstructing the jet.
4. Assemble the new filter-drier.
5. Open condenser stop valve and check dehydrator connections for refrigerant leaks.
6. Open all the dehydrator stop valves to allow the liquid refrigerant to flow through the dehydrator and condenser gas through the eductor.

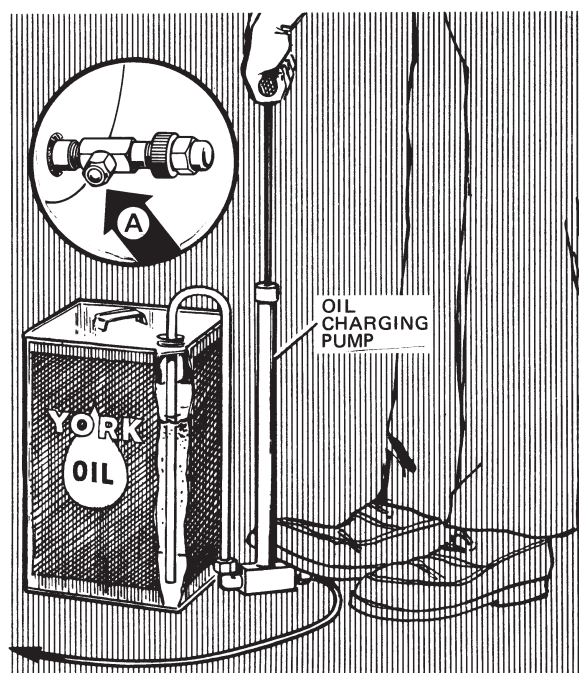
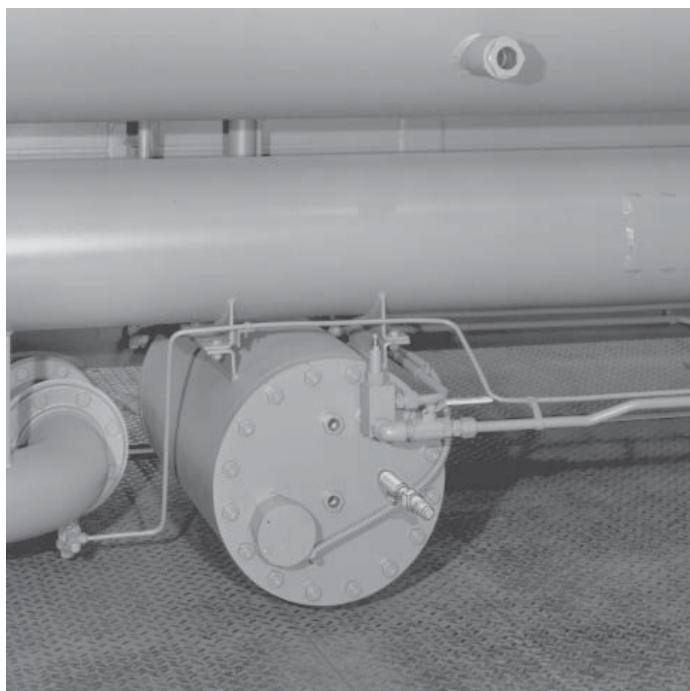

**Figure 7.2 Oil Reservoir Charging**

### 7.3 Oil Charge

The nominal oil charge for the compressor is 75.7 litres, of York “K” oil. Only York “K” refrigeration oil must be used in the centrifugal compressor. Since oil absorbs moisture when exposed to the atmosphere, it should be kept tightly capped until used.

#### 7.3.1 Oil Charging Procedure

The compressor oil level must be maintained between the oil reservoir’s upper and lower sight glasses. If the oil level falls into the lower sight glass, it is necessary to add oil to the compressor oil reservoir. The oil should be charged into the oil reservoir using the an oil charging pump (Part No. 070-10654). To charge oil into the oil reservoir, proceed as follows:

1. The unit must be shut down.
2. Immerse the suction connection of the oil charging pump in a clean container of new oil and connect the pump discharge connection to the oil charging valve (A) located on the oil reservoir cover plate. (figure 7.2). Do not tighten the connection at the charging valve until after the air is forced out by pumping a few strokes of the oil pump. This fills the lines with oil and prevents air from being pumped into the system.
3. Open the oil charging valve and pump oil into the system until oil level in the compressor oil reservoir is about midway in the upper sight glass. Then, close the charging valve and disconnect the hand oil pump.

4. As soon as oil charging is complete, restore the power supply to energise the oil heater. This will keep the concentration of refrigerant in the oil to a minimum.



When the oil reservoir is initially charged with oil, the oil pump should be started manually to fill the lines, passages, oil cooler and oil filter. This will lower the oil level in the reservoir. It will then be necessary to add oil to bring the level back to the centre of the upper sight glass.

### 7.4 Refrigerant Charge

The refrigerant system is pressure tested and evacuated at the factory.

#### 7.4.1 Checking The Refrigerant Charge

**The refrigerant level should have been observed and the level recorded after initial charging. With the correct charge the level should be visible in the sight glass.**



The refrigerant charge should always be checked and trimmed when the system is shut down.

The refrigerant charge level must be checked after the pressure and temperature have equalised between the condenser and evaporator. This would be expected to be 4 hours or more after the compressor and water pumps are stopped.

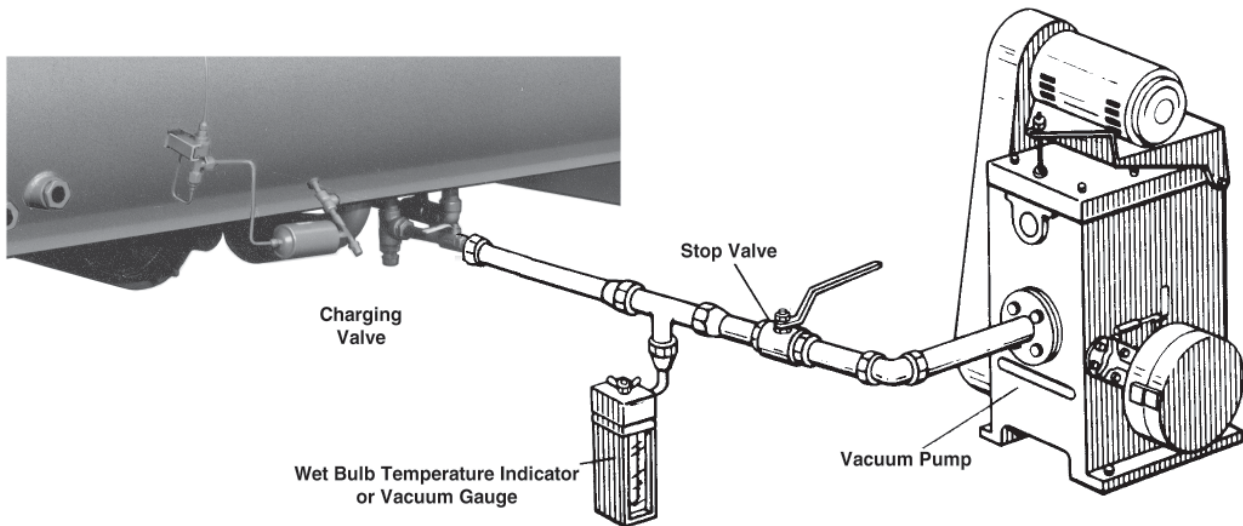

**Figure 7.3 Unit Evacuation**

### 7.4.2 Leak Testing

After the system has been charged, the system should be carefully leak tested with a R134a compatible leak detector to ensure all joints are tight.

Otherwise, it is recommended to perform a leak test quarterly.

If any leaks are indicated, they must be repaired immediately. Usually, leaks can be stopped by tightening flare nuts or flange bolts. However, for any major repair, the refrigerant charge must be removed.

### 7.4.3 Vacuum Testing

Vacuum testing should be conducted as follows:

1. Connect a high capacity vacuum pump, with indicator, to the system charging valve as shown in figure 7.3 and start the pump.
2. Open wide all system valves. Be sure all valves to the atmosphere are closed.
3. Operate the vacuum pump until a wet bulb temperature of 0°C or a pressure of 5 mm Hg (absolute) is reached.
4. To improve evacuation circulate warm water (not to exceed 50°C) through the evaporator and condenser tubes to thoroughly dehydrate the shells. If a source of hot water is not readily available, a portable water heater should be employed. **DO NOT USE STEAM.**

A suggested method is to connect a hose between the source of hot water under pressure and the evaporator head drain connection, out the evaporator vent connection, into the condenser head drain and out the condenser vent. To avoid the possibility of

causing leaks, the temperature should be brought up slowly so that the tubes and shell are heated evenly.

5. Close the system charging valve and the stop valve between the vacuum indicator and the vacuum pump. Then disconnect the vacuum pump leaving the vacuum indicator in place.
6. Hold the vacuum in the system for 8 hours; the slightest rise in pressure indicates a leak or the presence of moisture, or both. If, after 8 hours the wet bulb temperature in the vacuum indicator has not risen above 4.4°C or a pressure of 6.3 mm Hg, the system may be considered tight.

Be sure the vacuum indicator is valved off while holding the system vacuum and be sure to open the valve between the vacuum indicator and the system when checking the vacuum after the 8 hour period.

7. If the vacuum does not hold for 8 hours within the limits specified, the leak must be found and repaired.

#### 7.4.4 Refrigerant Charging



When opening any part of the refrigerant system for repairs, the refrigerant charge must be removed. If the chiller is equipped with optional valves, the refrigerant can be isolated in either the condenser or evaporator / compressor while making repairs.

To prevent liquid freezing within the evaporator tubes when charging an evacuated system, only refrigerant vapour must be added to the system until the system pressure is raised above the point corresponding to the freezing point of the evaporator liquid. For water, the pressure corresponding to the freezing point is 58.9 kPa for R134a (at sea level).



While charging, care must be taken to prevent moisture laden air from entering the system.

Make up a suitable charging connection from new copper tubing to fit between the system charging valve and the fitting on the charging drum. This connection should be as short as possible but long enough to permit sufficient flexibility for changing drums. The charging connection should be purged each time a new container of refrigerant is connected and changing containers should be done as quickly as possible to minimise the loss of refrigerant.

Refer to Section 9.2 for details of refrigerant charge weights.

### 7.5 Condenser and Evaporator

The major portion of maintenance on the condenser and evaporator is maintaining the water side of the condenser and evaporator in a clean condition.

The use of untreated water in cooling towers, closed water systems, etc. frequently results in one or more of the following:

1. Scale Formation.
2. Corrosion or Rusting.
3. Slime and Algae Formation.

It is therefore to the benefit of the user to provide for proper water treatment to provide for a longer and more economical life of the equipment. The following recommendation should be followed in determining the condition of the water side of the condenser and evaporator tubes.

1. The condenser tubes should be cleaned annually or earlier if conditions warrant. If the temperature difference between the water off the condenser and the condenser liquid temperature is more than 2.2 K greater than the difference recorded on a new unit, it is a good indication that the condenser tubes require cleaning.
2. The evaporator tubes under normal circumstances will not require cleaning. If however the temperature difference between the refrigerant and the chilled water increases slowly over the operating season, it is an indication that the evaporator tubes may be fouling or that there may be a water by-pass in the water box requiring gasket replacement or refrigerant may have leaked from the chiller.

#### 7.5.1 Chemical Water Treatment

Since the mineral content of the water circulated through the evaporator and condenser varies with almost every source of supply, it is possible that the water being used may corrode the tubes or deposit heat resistant scale in them. Reliable water treatment will greatly reduce the corrosive and scale forming properties of almost any type of water.

As a preventive measure against scale and corrosion and to prolong the life of evaporator and condenser tubes, a chemical analysis of the water should be made preferably before the system is installed. A water treatment expert should be consulted to determine whether water treatment is necessary, and if so, to furnish the proper treatment for the particular water condition.

#### 7.5.2 Tube Cleaning

##### Evaporator

It is difficult to determine by any particular test whether possible lack of performance of the water evaporator is due to fouled tubes alone or due to a combination of troubles. Trouble which may be due to fouled tubes is indicated when, over a period of time, the cooling capacity decreases and the split (temperature difference between water leaving the evaporator and the refrigerant temperature in the evaporator) increases. A gradual drop-off in cooling capacity can also be caused by a gradual leak of refrigerant from the system or by a combination of fouled tubes and shortage of refrigerant charge. An excessive quantity of oil in the evaporator can also contribute to erratic performance.

### Condenser

Condenser trouble due to fouled tubes is usually indicated by a steady rise in head pressure, over a period of time, accompanied by a steady rise in condensing temperature, and noisy operation. These symptoms may also be due to foul gas build-up. Purging will remove the foul gas revealing the effect of fouling.

### Tube Fouling

Fouling of the tubes can be due to deposits of two types as follows:

1. **Rust or sludge** - which finds its way into the tubes and accumulates there. This material usually does not build up on the inner tube surfaces as scale, but does interfere with the heat transfer. Rust or sludge can generally be removed from the tubes by a thorough brushing process.
2. **Scale** - due to mineral deposits. These deposits, even though very thin and scarcely detectable upon physical inspection, are highly resistant to heat transfer. They can be removed most effectively by circulating an acid solution through the tubes.

### 7.5.3 Tube Cleaning Procedures

#### Brush Cleaning of Tubes

If the tube consists of dirt and sludge, it can usually be removed by means of the brushing process. Drain the water sides of the circuit to be cleaned (cooling water or chilled water) remove the heads and thoroughly clean each tube with a soft bristle bronze or nylon brush. **DO NOT USE A STEEL BRISTLE BRUSH.** A steel brush may damage the tubes.

Improved results can be obtained by admitting water into the tube during the cleaning process. This can be done by mounting the brush on a suitable length of 1/8" pipe with a few small holes at the brush end and connecting the other end by means of a hose to the water supply.



The tubes should always be brush cleaned before acid cleaning.

### Acid Cleaning of Tubes

If the tubes are fouled with a hard scale deposit, they may require acid cleaning. It is important that before acid cleaning, the tubes be cleaned by the brushing process described above. If the relatively loose foreign material is removed before the acid cleaning, the acid solution will have less material to dissolve and flush from the tubes with the result that a more satisfactory cleaning job will be accomplished with a probable saving of time.

Acid cleaning should only be performed by an expert. Please consult your local water treatment representative for assistance in removing scale build-up and preventative maintenance programs to eliminate future problems.

### 7.5.4 Tube Leaks

Evaporator and condenser tube leaks may result in refrigerant leaking into the water circuit, or water leaking into the shell depending on the pressure levels. If refrigerant is leaking into the water, it can be detected at the liquid head vents after a period of shutdown. If water is leaking into the refrigerant, system capacity and efficiency will drop off sharply.

If a tube is leaking and water has entered the system, the evaporator and condenser should be valved off from the rest of the water circuit and drained immediately to prevent severe rusting and corrosion. The refrigerant system should then be drained and purged with dry nitrogen to prevent severe rusting and corrosion. If a tube leak is indicated, the exact location of the leak may be determined as follows:

1. Remove the heads and listen at each section of tubes for a hissing sound that would indicate gas leakage. This will assist in locating the section of tubes to be further investigated. If the probable location of the leaky tubes has been determined, treat that section in the following manner (if the location is not definite, all the tubes will require investigation).
2. Wash off both tube heads and the ends of all tubes with water.
3. With nitrogen or dry air, blow out the tubes to clear them of traces of refrigerant laden moisture from the circulation water. As soon as the tubes are clear, a cork should be driven into each end of the tube. Pressurise the dry system with 350 to 690 kPag of nitrogen. Repeat this with all of the other tubes in the suspected section or, if necessary, with all the tubes in the evaporator or condenser. Allow the evaporator or condenser to remain corked up to 12 to 24 hours before proceeding. Depending upon the amount of leakage, the corks may blow from the end of a tube, indicating the location of the leakage. If not, it will be necessary to make a very thorough test with the leak detector.

4. After the tubes have been corked for 12 to 24 hours, it is recommended that two men working at both ends of the evaporator carefully test each tube – one man removing corks at one end and the other at the opposite end to remove corks and handle the leak detector. Start with the top row of tubes in the section being investigated. Remove the corks at the ends of one tube simultaneously and insert the exploring tube for 5 seconds – this should be long enough to draw into the detector any refrigerant gas that might have leaked through the tube walls. A fan placed at the end of the evaporator opposite the detector will assure that any leakage will travel through the tube to the detector.
  5. Mark any leaking tubes for later identification.
  6. If any of the tube sheet joints are leaking, the leak should be indicated by the detector. If a tube sheet leak is suspected, its exact location may be found by using a soap solution. A continuous buildup of bubbles around a tube indicates a tube sheet leak.
2. **Oil Changing** - The oil in the compressor must be changed annually or earlier if it becomes dark or cloudy. However, quarterly oil analysis can eliminate the need for an annual change provided the analysis indicates there is no problem with the oil.

## 7.7 Compressor Motor

1. Check motor mounting screws frequently for tightness.
2. Check motor winding insulation annually for deterioration of windings.
3. For the lubrication instructions, refer to the motor manual

## 7.6 Compressor

Maintenance for the compressor assembly consists of checking the operation of the oil return system and changing the dehydrator, checking and changing the oil, checking and changing the oil filters, checking the operation of the oil heater, checking the operation of the oil pump, and observing the operation of the compressor.

Internal wearing of compressor parts could be a serious problem caused by improper lubrication, brought about by restricted oil lines, passages, or dirty oil filters. If the unit is shutting down on (HOT) High Oil Temperature or Low Oil Pressure (OP), change the oil filter element. Examine the oil filter element for the presence of aluminum particles. Aluminum gas seal rings can contact the impeller and account for some aluminum particles to accumulate in the oil filter, especially during the initial start up and first several months of operation. However, if aluminum particles continue to accumulate and the same conditions continue to stop the unit operation after a new filter is installed, contact your local York Service Agent.

1. **Oil Filter** - The oil filter must be changed when the variable speed oil pump (VSOP) Drive frequency increases to 55 Hz to maintain the target oil pressure

When the oil filter is changed, it should be inspected thoroughly for any aluminum particles which would indicate possible bearing wear. If aluminum particles are found this should be brought to the attention of the nearest York office for their further investigation and recommendations.

### 7.8 Electrical Controls

1. All electrical controls should be inspected for obvious malfunctions.
2. It is important that the factory settings of controls (operation and safety) are not changed. If the settings are changed without York approval, the warranty will be invalidated.

For information covering the graphic control centre (OptiView) operation, refer to manual 160.54-O1.

### 7.9 Testing Motor Winding Insulation

With the main disconnect switch and compressor motor starter open, test the motor as follows:

1. Test the insulation, using a megohm meter (megger), between phases and each phase and ground (see figure 7.4); these readings are to be interpreted using the graph shown in figure 7.5.
2. If readings fall below shaded area, remove external leads from motor and repeat test.



Motor is to be megged with the starter at ambient temperature after 24 hours of idle standby.

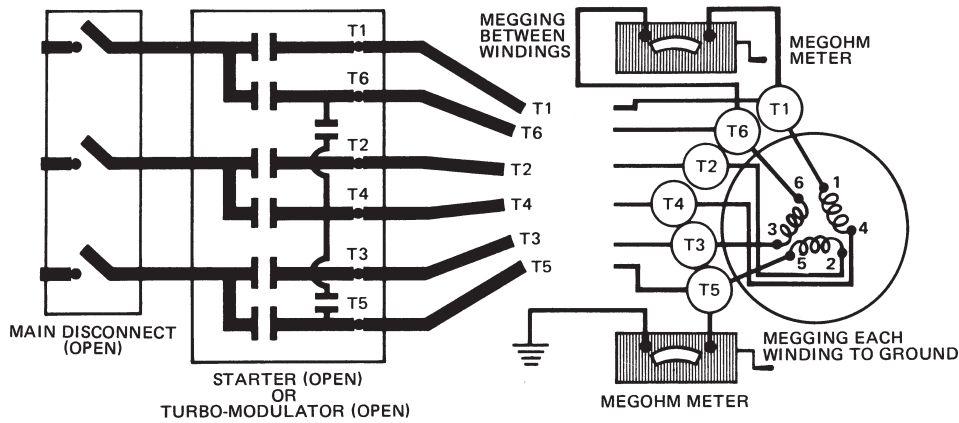

Figure 7.4 Insulation Testing of Motor Windings

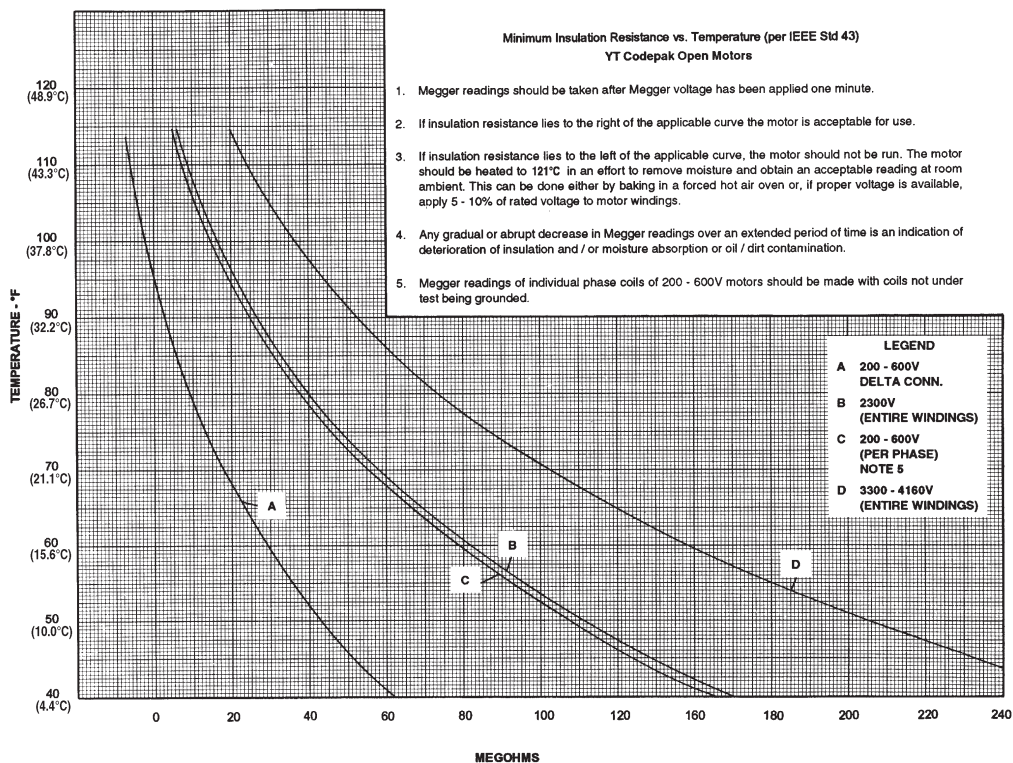

Figure 7.5 Motor Stator Insulation Resistance



## 8 TROUBLESHOOTING

Fault	Possible Cause	Remedy
<b>1. SYMPTOM: Abnormally High Discharge Pressure</b>		
Temperature difference between condensing temperature and condenser leaving liquid temperature higher than normal.	Air in condenser.	Bleed cooling water circuit.
High discharge pressure.	Condenser tubes dirty or scaled.	Clean condenser tubes. Check water treatment.
	High condenser water temperature.	Reduce condenser water inlet temperature. (Check cooling tower and water circulation.)
Temperature difference between condenser entering liquid and condenser leaving liquid higher than normal, with normal evaporator pressure.	Insufficient condensing water flow.	Increase the water flow through the condenser to correct value.
<b>2. SYMPTOM: Abnormally Low Suction Pressure</b>		
Temperature difference between leaving chilled water and refrigerant in evaporator greater than normal with high discharge temperature.	Insufficient charge of refrigerant.	Check for leaks and charge refrigerant into system.
	Variable orifice problem.	Remove obstruction.
Temperature difference between leaving chilled water and refrigerant in the evaporator greater than normal with normal discharge temperature	Evaporator tubes dirty or restricted.	Clean evaporator tubes.
Temperature of chilled water too low with low motor current.	Insufficient load for system capacity.	Check pre-rotation vane motor operation and setting of low water temperature cut-out.
<b>3. SYMPTOM: High Evaporator Pressure</b>		
High chilled water temperature.	Pre-rotation vanes fail to open.	Check the pre-rotation vane motor positioning circuit.
	System overload.	Be sure the vanes are wide open (without overloading the motor) until the load decreases.
<b>4. SYMPTOM: No Oil Pressure when System Start Button Pushed</b>		
Low oil pressure displayed on control centre; compressor will not start.	Oil pump running in wrong direction.	Check rotation of oil pump (Electrical Connections).
	Oil pump not running.	Troubleshoot electrical problem with oil pump VSD.

Fault	Possible Cause	Remedy
5. SYMPTOM: Unusually High Oil Pressure develops when Oil Pump Runs		
Unusually high oil pressure is displayed when the oil pressure display key is pressed when the oil pump is running.	High oil pressure. Transducer defective.	Replace low or high oil pressure transducer.
6. SYMPTOM: Oil Pump Vibrates or is Noisy		
Oil pump vibrates or is extremely noisy with some oil pressure when pressing OIL PRESSURE display key. <b>Note: When oil pump is run without an oil supply it will vibrate and become extremely noisy.</b>	Oil not reaching pump suction inlet in sufficient quantity.	Check oil supply and oil piping.
	Worn or failed oil pump.	Repair/Replace oil pump.
7. SYMPTOM: Reduced Oil Pump Capacity		
Oil pump pumping capacity.	Excessive end clearance on pump. Other worn pump parts.	Inspect and replace worn parts.
	Partially blocked oil supply inlet.	Check oil inlet for blockage.
8. SYMPTOM: Oil Pressure Gradually Decreases (Noted by Observation of Daily Log Sheets)		
When oil pump VSD frequency increases to 55 + hz to maintain target oil pressure.	Oil filter is dirty.	Change oil filter.
9. SYMPTOM: Oil Pressure System Ceases to return an Oil/Refrigerant Sample		
Oil refrigerant return not functioning.	Filter-drier in oil return system dirty.	Replace old filter-drier with new.
	Jet or orifice of oil return jet clogged.	Remove jet, inspect for dirt. Remove dirt using solvent and replace.
10. SYMPTOM: Oil Pump Fails to deliver Oil Pressure		
No oil pressure registers when pressing OIL PRESSURE display key when oil pump runs	Faulty oil pressure transducer. Faulty wiring/connectors.	Replace oil pressure transducer.

## 9 TECHNICAL DATA

### 9.1 Dimensions

#### P and Q Compressors

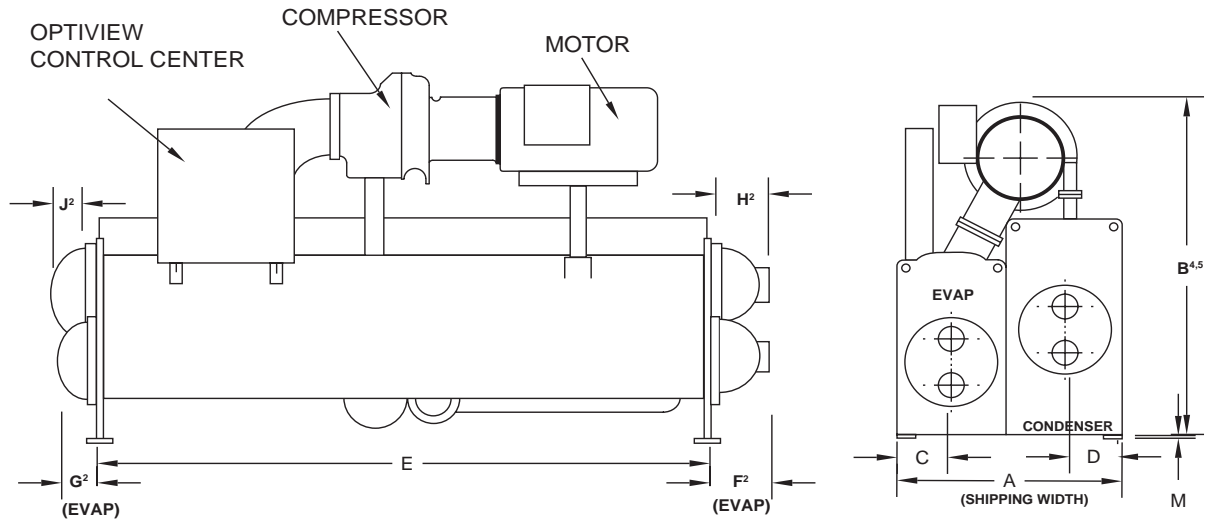

ADDITIONAL OPERATING HEIGHT CLEARANCE TO FLOOR	
TYPE OF CHILLER MOUNTING	M
NEOPRENE PAD ISOLATORS	45
SPRING ISOLATORS 1" DEFLECTION	25
DIRECT MOUNT	19

Q3 COMPRESSOR			
EVAPORATOR-CONDENSER SHELL CODES			
	A-A	C-C	D-D
A	1549	1676	1676
B	2134	2229	2229
C	394	445	445
D	381	394	394
E	3658	3658	4877

P7, Q7 COMPRESSOR		
EVAPORATOR-CONDENSER SHELL CODES		
	E-E	F-F
A	1880	1880
B	2454	2454
C	495	495
D	445	445
E	3658	4877

Q4 COMPRESSOR			
EVAPORATOR-CONDENSER SHELL CODE			
	C-C	D-D	E-E
A	1676	1676	2134
B	2197	2197	2350
C	445	445	495
D	394	394	445
E	3658	4877	3658

P8 COMPRESSOR				
EVAPORATOR-CONDENSER SHELL CODES				
	G-E	H-F	J-J	L-L
A	2108	2108	2299	2299
B	3200	3200	3327	3327
C	610	610	641	641
D	445	445	508	508
E	3658	4877	3658	4877

Q5 COMPRESSOR				
EVAPORATOR-CONDENSER SHELL CODES				
	C-C	D-D	E-E	F-F
A	1676	1676	2134	2134
B	2403	2403	2578	2578
C	445	445	495	495
D	394	394	445	445
E	3658	4877	3658	4877

P9 COMPRESSOR			
EVAPORATOR-CONDENSER SHELL CODES			
	H-F	J-J	L-L
A	2108	2299	2299
B	3124	3264	3264
C	610	641	641
D	445	508	508
E	4877	3658	4877

Q6 COMPRESSOR		
EVAPORATOR-CONDENSER SHELL CODES		
	E-E	F-F
A	2134	2134
B	2515	2515
C	495	495
D	445	445
E	3658	4877

### H Compressors

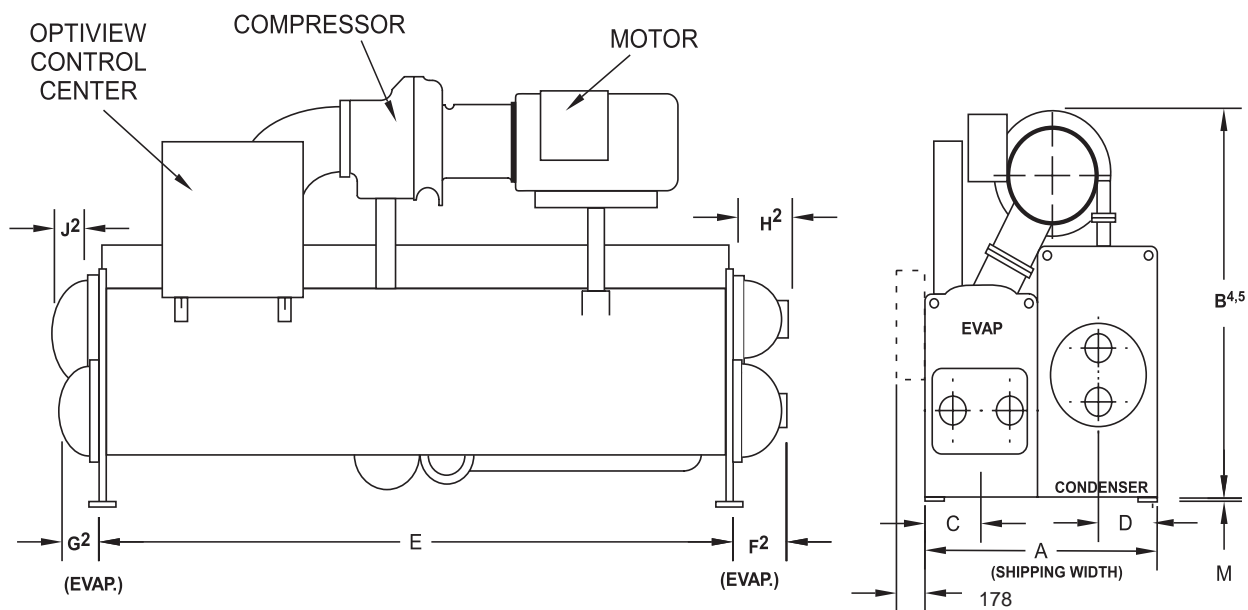

ADDITIONAL OPERATING HEIGHT CLEARANCE	
TYPE OF CHILLER MOUNTING	M
NEOPRENE PAD ISOLATORS	44
SPRING ISOLATORS 25MM DEFLECTION	25
DIRECT MOUNT	19

H9 COMPRESSORS		
EVAP.-COND. SHELL CODES		
	K-K	M-M
A	2299	2616
B	3150	3315
C	641	724
D	508	584
E	4267	4267

**NOTES:**

1. All dimensions are approximate. Certified dimensions are available on request.
2. For all water boxes (compact shown above), determine overall unit length by adding water box depth to tube sheet length.
3. Water nozzles can be located on either end of unit. Add 13 mm to nozzle length for flanged connections.
4. To determine overall height, add dimension "M" for the appropriate isolator type.
5. Use of motors with motor hoods may increase overall unit dimensions.

**K Compressors**

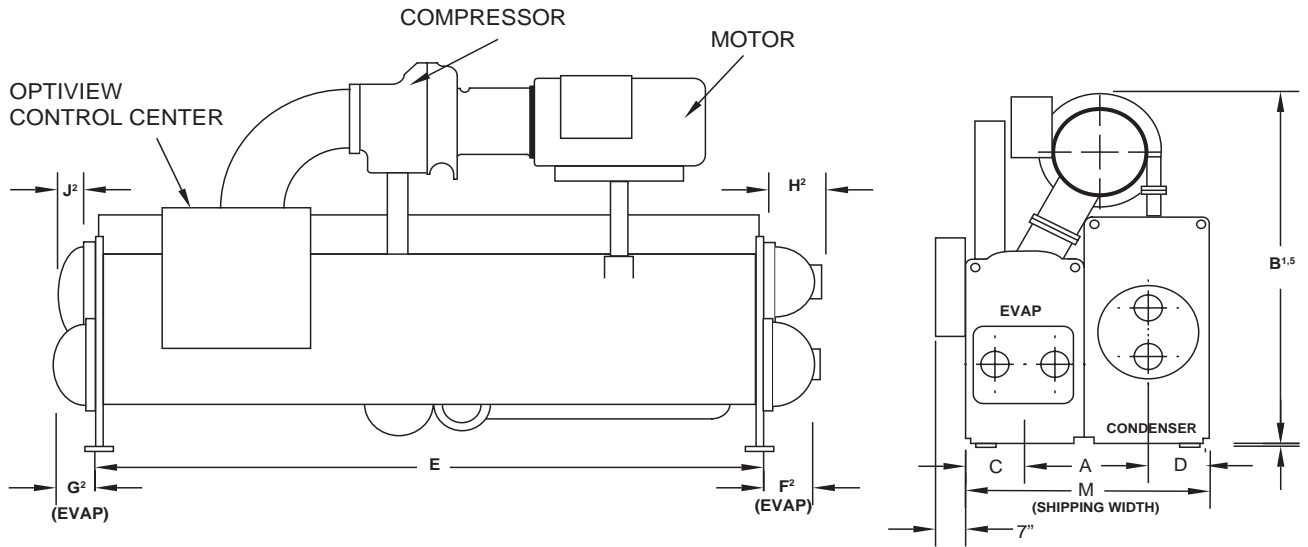

K1 COMPRESSOR, EVAPORATOR-CONDENSER S HELL CODES					
	K-K	M-M	N-N	P-P	Q-Q
A	2299	2616	2616	2781	2781
B	2921	3454	3454	3493	3493
C	641	724	724	749	749
D	508	584	584	641	641
E	4267	4267	4877	4267	4877

K2 COMPR., EVAPORATOR-CONDENSER S HELL CODES				
	M-M	N-N	P-P	Q-Q
A	2616	2616	2781	2781
B	3454	3454	3480	3480
C	724	724	749	749
D	584	584	641	641
E	4267	4877	4267	4877

K4 COMPRESSOR, EVAPORATOR-CONDENSER S HELL CODES					
	R-R	S-S	S-V	X-T	X-X
A	2972	2972	3124	3302	3429
B	3632	3632	3759	3759	3759
C	813	813	813	902	902
D	699	699	749	749	813

ADDITIONAL OPERATING HEIGHT CLEARANCE	
TYPE OF CHILLER MOUNTING	M
NEOPRENE PAD ISOLATORS	44
SPRING ISOLATORS 1" DEFLECTION	25
DIRECT MOUNT	19

K3 COMPR, EVAP.-COND SHELL CODES			
	N-N	Q-Q	R-R
A	2616	2781	2972
B	3251	3505	3607
C	724	749	813
D	584	641	699
E	4877	4877	4877

K7 COMPR, EVAP.-COND SHELL CODES		
	W-W	Z-Z
A	3124	3429
B	3708	3912
C	813	902
D	749	813

**NOTES:**

1. All dimensions are approximate. Certified dimensions are available on request.
2. For all water boxes (compact shown above), determine overall unit length by adding water box depth to tube sheet length.
3. Water nozzles can be located on either end of unit. Add 13 mm to nozzle length for flanged connections.
4. To determine overall height, add dimension "M" for the appropriate isolator type.
5. Use of motors with motor hoods may increase overall unit dimensions.
6. Tubesheets are provided with jacking point notches on P and larger shells.

### 9.2 Dimensions - Evaporator Compact Water Boxes

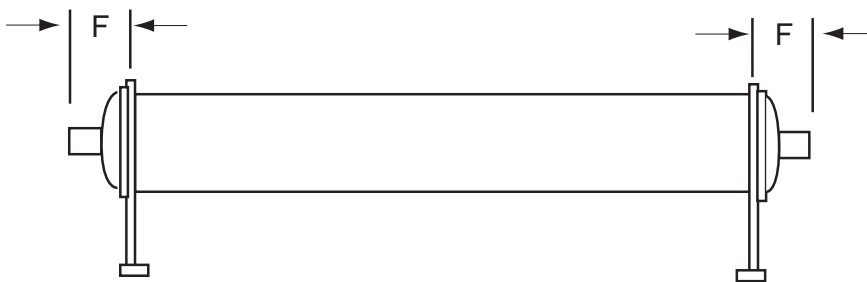

ONE PASS EVAPORATORS, CODES

DIM.	A	C,D	E,F	G,H	J,K,L	M,N	P,Q	R,S,W	X,Z
F	362	381	394	400	445	600	600	625	654



TWO PASS EVAPORATORS, CODES

DIM.	A	C,D	E,F	G,H	J,K,L	M,N	P,Q	R,S,W	X,Z
F	362	381	394	400	445	600	600	625	654
G	165	178	191	197	241	397	397	425	451

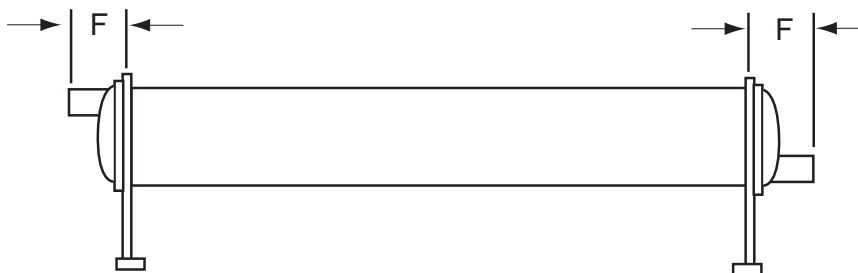

THREE PASS EVAPORATORS, CODES

DIM.	A	C,D	E,F	G,H	J,K,L	M,N	P,Q	R,S,W	X,Z
F	362	381	394	400	445	600	600	625	654

### 9.3 Nozzle Arrangements - Evaporator Compact Water Boxes

#### A to K Evaporators

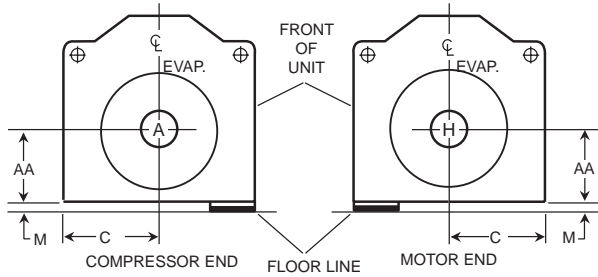

1-PASS

NOZZLE ARRANGEMENTS		
NO. OF PASSES	EVAPORATOR	
	IN	OUT
1	A	H
	H	A

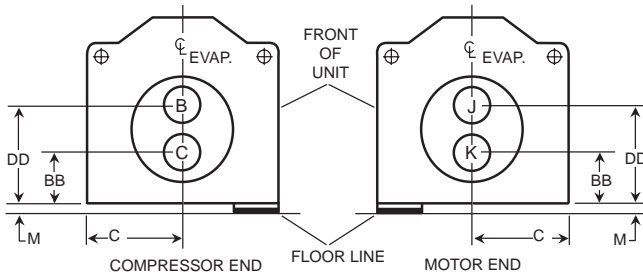

2-PASS

NOZZLE ARRANGEMENTS		
NO. OF PASSES	EVAPORATOR	
	IN	OUT
2	C	B
	K	J

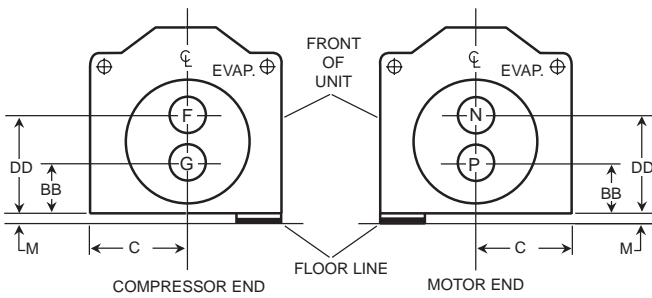

3-PASS

NOZZLE ARRANGEMENTS		
NO. OF PASSES	EVAPORATOR	
	IN	OUT
3	G	N
	P	F

COMPACT WATER BOXES - 150PSI ROUND

CONDENSER SHELL CODE	NOZZLE PIPE SIZE(IN)			EVAPORATOR NOZZLE DIMENSIONS(MM)					
	NO. OF PASSES			C	1-PASS	2-PASS		3-PASS	
	1	2	3		AA <sup>5</sup>	BB <sup>5</sup>	DD <sup>5</sup>	BB <sup>5</sup>	DD <sup>5</sup>
A	8	6	4	394	559	356	762	356	762
C,D	10	8	6	445	610	381	838	381	838
E,F	14	10	8	483	660	406	914	406	914
G,H	14	10	8	610	699	394	1003	394	1003
J,K,L	16	12	10	641	762	432	1092	432	1092

Evaporators - Compact Water Boxes - M to Z Evaporators

1 PASS

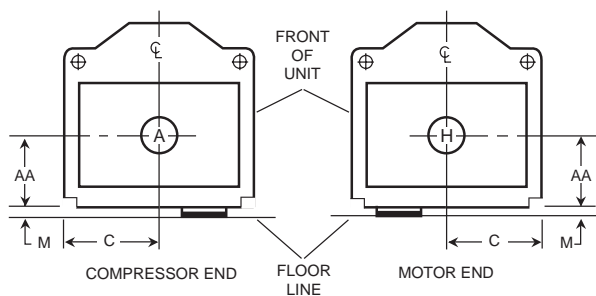

SHELL CODE	1 PASS	
	IN	OUT
M-Z	A	H
	H	A

2 PASS

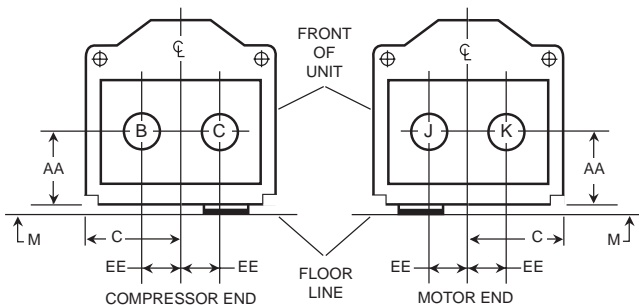

SHELL CODES	2 PASS	
	IN	OUT
M-Z	B	C
	C	B
	J	K
	K	J

3 PASS

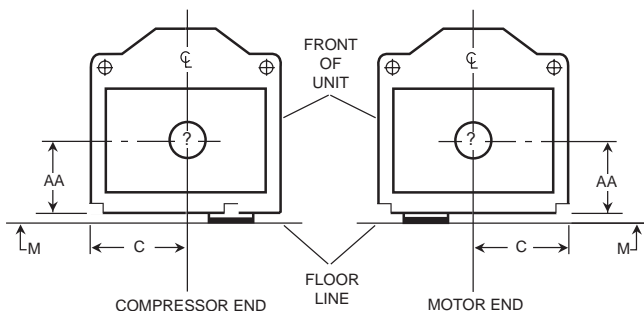

SHELL CODES	3 PASS	
	IN	OUT
M-Z	F	N
	N	F

COMPACT WATER BOXES - 150PSI RECTANGULAR

EVAP SHELL CODE	NOZZLE PIPE SIZE(IN)			EVAPORATOR NOZZLE DIMENSIONS(MM)				
	NO. OF PASSES			C	1-PASS	2-PASS	EE	3-PASS
	1	2	3		AA5	AA5		AA5
M,N	18	14	12	724	660	660	318	660
P,Q	18	14	12	749	679	679	318	679
QV,QT	20	16	12	749	679	679	318	679
RP,RR,RT, R2,R4,R6,W	20	18	14	813	789	789	381	789
RQ,RS,RV, R3,R4,R5,S	20	18	14	813	819	819	381	819
X,Z	20	18	14	902	876	876	381	876



## 9.4 Dimensions - Condenser Compact Water Boxes

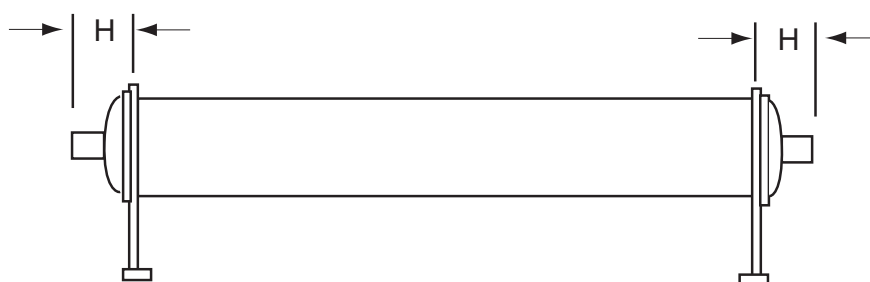

ONE PASS CONDENSERS, CODES

DIM.	A	C,D	E,F	J,K,L	M,N	P,Q	R,S	T,V,W	X,Z
H	352	352	381	394	391	445	492	495	492



TWO PASS CONDENSERS, CODES

DIM.	A	C,D	E,F	J,K,L	M,N	P,Q	R,S	T,V,W	X,Z
H	352	352	381	394	391	445	492	495	492
J	149	165	178	191	197	241	298	279	279

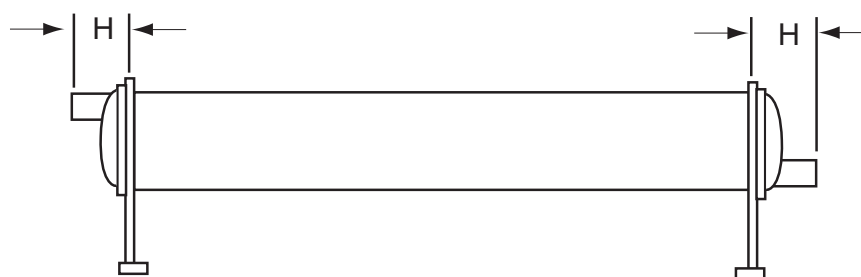

THREE PASS CONDENSERS, CODES

DIM.	A	C,D	E,F	J,K,L	M,N	P,Q	R,S	T,V,W	X,Z
H	352	352	381	394	391	445	492	495	492

### 9.5 Nozzle Arrangements - Condenser Compact Water Boxes

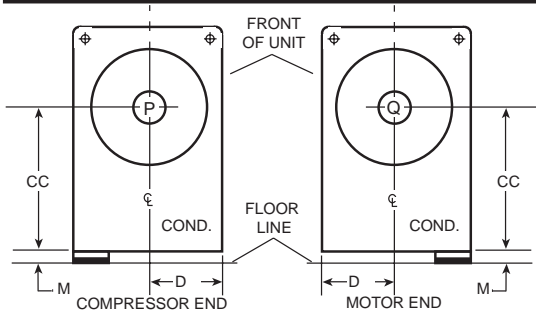

**1-PASS**

NOZZLE ARRANGEMENTS		
NO. OF PASSES	COND.	
	IN	OUT
1	P	Q
	Q	P

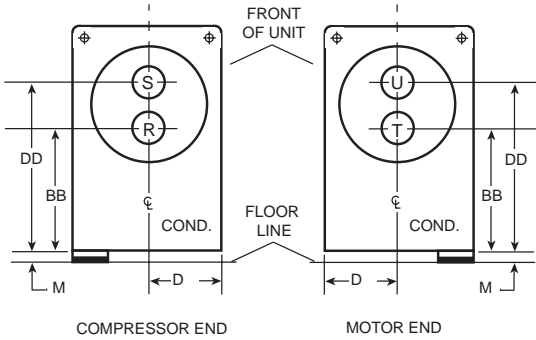

**2-PASS**

NOZZLE ARRANGEMENTS		
NO. OF PASSES	COND.	
	IN	OUT
2	R	S
	T	U

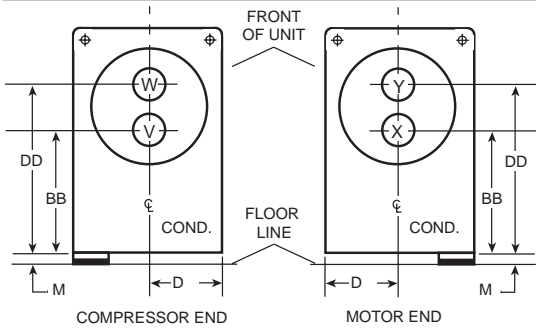

**3-PASS**

NOZZLE ARRANGEMENTS		
NO. OF PASSES	COND.	
	IN	OUT
3	V	Y
	X	W

COMPACT WATER BOXES - 150PSI ROUND

CONDENSER SHELL CODE	NOZZLE PIPE SIZE(IN)			D	1-PASS	2-PASS		3-PASS		
	NO. OF PASSES					CC <sup>5</sup>	BB <sup>5</sup>	DD <sup>6</sup>	BB <sup>5</sup>	DD <sup>6</sup>
	1	2	3							
A	10	6	6	381	711	546	876	546	876	
C,D	12	8	6	394	762	568	956	568	956	
E,F	14	10	8	445	813	603	1022	603	1022	
J,K,L	16	10	10	508	914	686	1143	686	1143	
M,N	20	14	10	584	1067	772	1362	772	1362	
P,Q	20	16	14	641	1118	787	1448	787	1448	
R,S	20	18	14	699	1181	851	1511	851	1511	
T,V,W	24	18	16	749	1207	838	1575	838	1575	
X,Z	24	20	16	813	1251	845	1657	845	1657	

**NOTES:**

- Standard water nozzles are furnished as welding stub-outs with Victaulic grooves, allowing the option of welding, flanges, or use of Victaulic couplings. Factory-installed, class 150 (ANSI B16.5, round slip-on, forged carbon steel with 1.6 mm raised face), water flanges nozzles are optional (add 13 mm to nozzle length). Companion flanges, nuts, bolts, and gaskets are not furnished.
- One, two and three pass nozzle arrangements are available only in pairs shown and for all shell codes. Any pair of evaporator nozzles may be used in combination with any pair of condenser nozzles.
- Evaporator and condenser water must enter the water box through the bottom connection to achieve rated performance.
- Connected piping should allow for removal of compact water boxes for tube access and cleaning.
- Add dimension "M" as shown on the unit dimensions page for the appropriate isolator type.
- Standard 150 psi (1034 kPa) design pressure water boxes shown.

9.6 Dimensions - Evaporator Marine Water Boxes

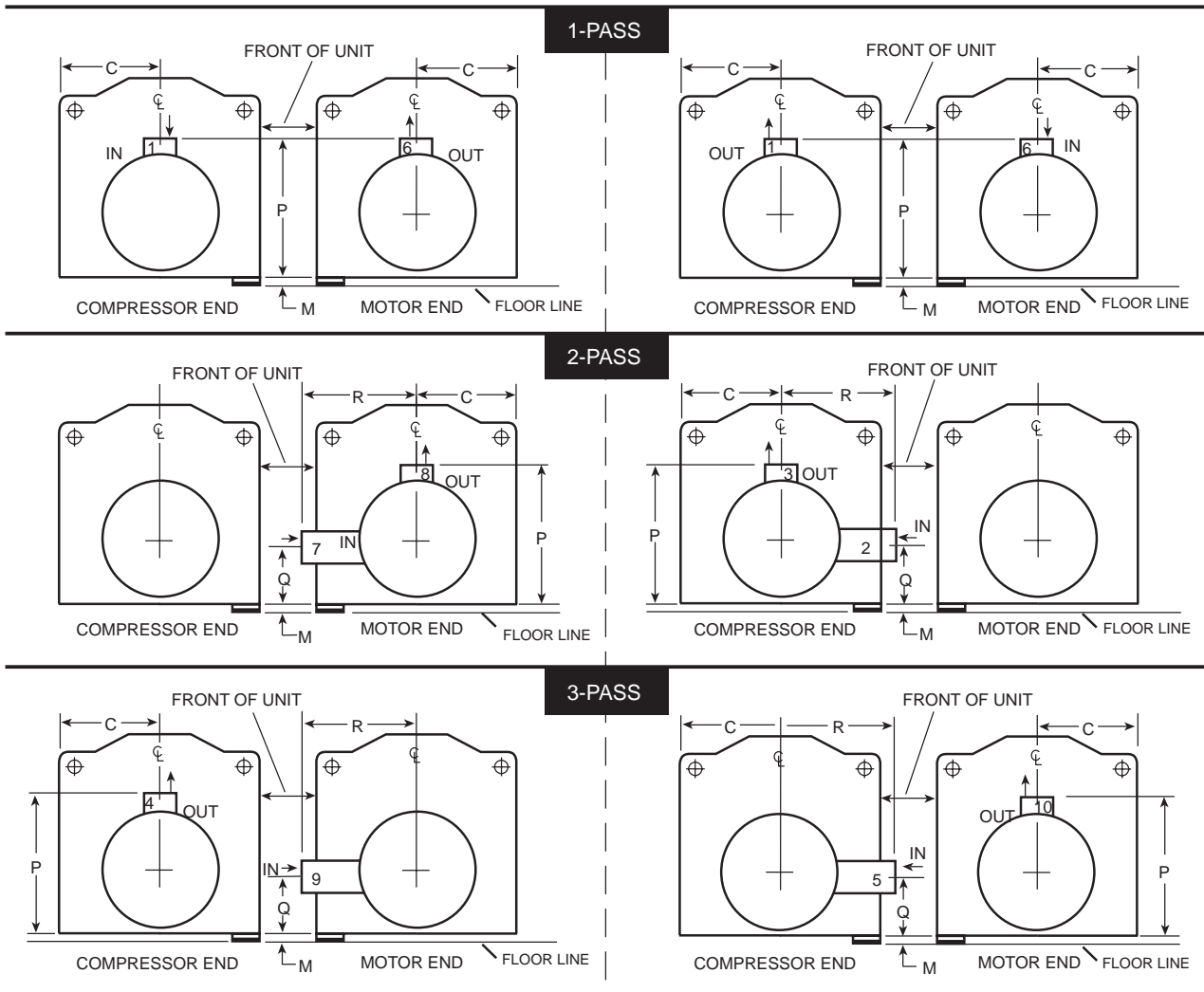

CONDENSER SHELL CODE				MARINE WATER BOXES - 150PSI ROUND							
EVAP SHELL CODE	NOZZLE PIPE SIZE(IN)			C	1-PASS	2-PASS			3-PASS		
	1	2	3			P <sup>5</sup>	Q <sup>5</sup>	R	P <sup>5</sup>	Q <sup>5</sup>	R
A	8	6	4	394	1092	1092	279	387	1092	279	387
C,D	10	8	6	445	1194	1194	254	470	1194	254	470
E,F	14	10	8	495	1295	1295	279	546	1295	279	546
G,H	14	10	8	610	1407	1407	267	597	1407	267	597
J,K,L	16	12	10	641	1534	1534	267	673	1534	267	673
M,N	18	14	12	724	1740	1740	356	673	1740	356	730
P,Q	18	14	12	749	1832	1832	381	775	1832	381	775
QT,QV	20	16	12	749	1832	1832	419	775	1832	419	775
R,S	20	18	14	813	1978	1978	-57	918	1978	-57	918
W	20	18	14	813	1978	1978	-57	918	1978	-57	918
X,Z	20	18	14	902	2169	2169	540	933	2169	540	933

### 9.8 Nozzle Arrangements - Evaporator Marine Water Boxes

EVAPORATOR 1-PASS	
IN	OUT
1	6
6	1

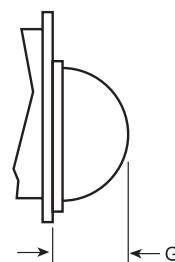
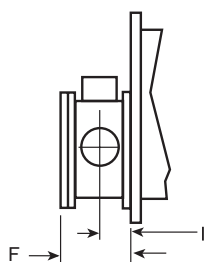

(2-PASS RETURN HEAD)

EVAPORATOR 2-PASS	
IN	OUT
2	3
7	8

EVAP SHELL CODE	1-PASS		2-PASS			3-PASS	
	F	I	F	G	I	F	I
A	483	222	432	165	197	432	197
C,D	578	270	524	178	241	524	241
E,F	654	308	559	191	260	559	260
G,H	660	302	572	286	260	572	260
J,K,L	686	314	597	241	268	597	267
M,N	762	343	660	308	292	660	292
P,Q	762	343	660	343	292	660	292
QT,QV	813	368	711	343	318	711	318
R,S,W	813	371	762	368	346	762	346
X,Z	838	371	762	394	346	762	346

EVAPORATOR 3-PASS	
IN	OUT
5	10
9	4

**NOTES:**

1. All dimensions are approximate. Certified dimensions are available upon request.
2. Standard water nozzles are Schedule 40 pipe size, furnished as welding stub-outs with Victaulic grooves, allowing the option of welding, flanges, or use of Victaulic couplings. Factory-installed, class 150 (ANSI B16.5, round slip-on, forged carbon steel with 1.6 mm raised face), water flanged nozzles are optional (add 13 mm to nozzle length). Companion flanges, nuts, bolts, and gaskets are not furnished.
3. One-, two-, and three-pass nozzle arrangements are available only in pairs shown and for all shell codes. Any pair of evaporator nozzles may be used in combination with any pair of condenser nozzles. Compact water boxes on one heat exchanger may be used with Marine Water Boxes on the other heat exchanger.
4. Water must enter the water box through the bottom connection to achieve rated performance.
5. Add dimension "M" as shown on the unit dimensions page for the appropriate isolator type.

### 9.8 Dimensions - Condenser Marine Water Boxes

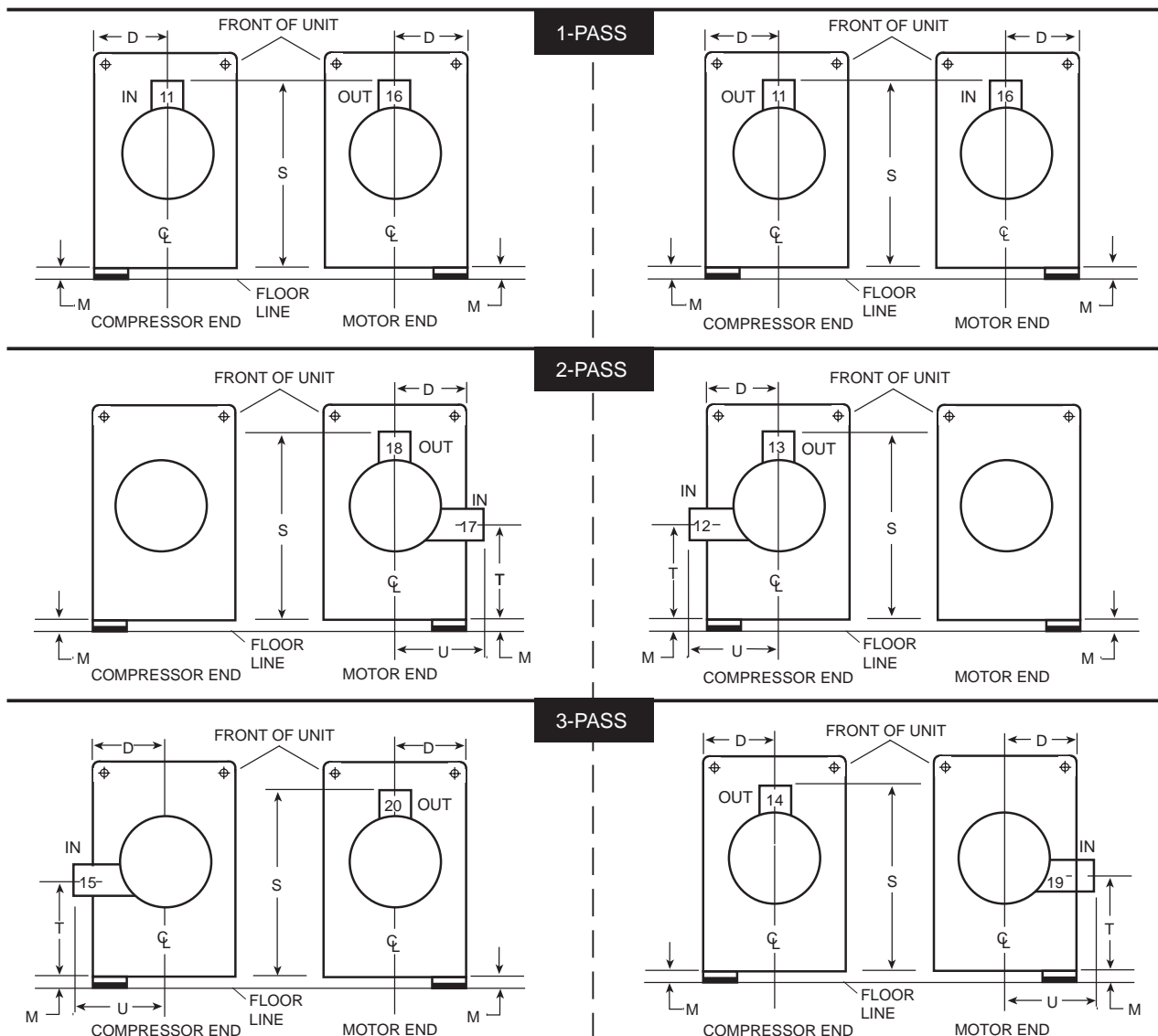

MARINE WATER BOXES - 150PSI ROUND

CONDENSER SHELL CODE	NOZZLE PIPE SIZE(IN)			D	1-PASS	2-PASS			3-PASS		
	NO. OF PASSES					S <sup>5</sup>	S <sup>5</sup>	T <sup>5</sup>	U	S <sup>5</sup>	T <sup>5</sup>
A	10	6	6	381	1194	1194	508	391	1194	508	391
C,D	12	8	6	394	1295	1295	508	470	1295	508	470
E,F	14	10	8	445	1397	1397	559	533	1397	559	533
J,K,L	16	10	10	508	1549	1549	533	546	1549	533	546
M,N	20	14	10	584	1775	1775	711	648	1775	711	648
P,Q	20	16	14	641	1889	1889	724	749	1889	724	749
R,S	20	18	14	699	2007	2007	775	826	2007	775	826
T,V,W	24	18	16	749	2089	2089	762	864	2089	762	864
X,Z	24	20	16	813	2184	2184	806	902	2184	806	902

### 9.8 Nozzle Arrangements - Condenser Marine Water Boxes

CONDENSER	
1-PASS	
IN	OUT
11	16
16	11

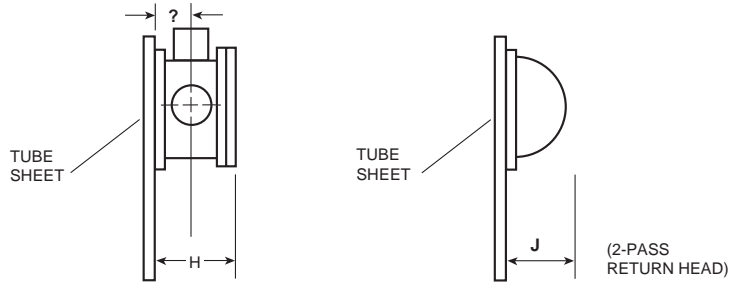

CONDENSER	
2-PASS	
IN	OUT
12	13
17	18

CONDENSER	
3-PASS	
IN	OUT
15	20
19	14

CONDSHELL CODE	1-PASS		2-PASS			3-PASS	
	H	K	H	J	K	H	K
A	533	251	425	152	197	425	197
C,D	610	283	495	162	229	495	229
E,F	622	292	565	178	251	565	251
J,K,L	686	318	584	191	260	584	260
M,N	813	378	660	203	305	660	305
P,Q	813	368	711	241	318	711	318
R,S	813	368	762	305	343	762	343
T,V,W	914	419	762	279	343	762	343
X,Z	914	422	813	279	371	813	356

**NOTES:**

1. All dimensions are approximate. Certified dimensions are available upon request.
2. Standard water nozzles are Schedule 40 pipe size, furnished as welding stub-outs with Victaulic grooves, allowing the option of welding, flanges, or use of Victaulic couplings. Factory-installed, class 150 (ANSI B16.5, round slip-on, forged carbon steel with 1.6 mm raised face), water flanged nozzles are optional (add 13 mm to nozzle length). Companion flanges, nuts, bolts, and gaskets are not furnished.
3. One-, two-, and three-pass nozzle arrangements are available only in pairs shown and for all shell codes. Any pair of evaporator nozzles may be used in combination with any pair of condenser nozzles. Compact water boxes on one heat exchanger may be used with Marine Water Boxes on the other heat exchanger.
4. Condenser water must enter the water box through the bottom connection for proper operation of the sub-cooler to achieve rated performance.
5. Add dimension "M" as shown on the unit dimension page for the appropriate isolator type.

## 9.9 Unit Weights

### 9.9.1 Approximate Unit Weight Including Motor

SHELLS	COMPRESSOR	SHIPPING WEIGHT (KGS.)	OPERATING WEIGHT (KGS.)	EST. REFRIGERANT CHARGE (KGS.)
A-A	Q3	5,942	6,804	367
C-C	Q3, Q4	6,768	8,138	562
C-C	Q5	6,954	8,324	562
D-D	Q3, Q4	7,809	9,571	762
D-D	Q5	7,995	9,757	762
E-E	Q3, Q4	8,142	10,052	776
E-E	Q5,Q6,Q7,P7	8,328	10,238	776
F-F	Q5,Q6,Q7,P7	8,491	10,832	987
G-E	P8	9,208	10,977	903
H-F	P8,P9	10,478	12,701	1,184
J-J	P8,P9	10,886	13,200	1,157
L-L	P8,P9	12,429	15,377	1,436
K-K	H9	12,941	16,329	1,327
K-K	K1	14,107	16,420	1,473
M-M	H9	15,513	19,777	1,662
M-M	K1,K2	17,373	21,364	1,662
N-N	K1,K2	18,549	23,043	1,916
N-N	K3	21,773	24,540	1,916
P-P	K1,K2	18,824	23,542	1,749
Q-Q	K1,K2	20,548	25,764	1,930
Q-Q	K3	20,865	27,307	1,930
R-R	K3	23,950	31,888	2,114
R-R	K4	24,041	32,024	2,170
S-S	K4	26,762	34,609	2,241
S-V	K4	27,261	36,877	2,495
X-T	K4	26,853	36,288	2,438
X-X	K4	29,937	39,463	2,665
W-W	K7	36,061	47,174	3,472
Z-Z	K7	36,515	47,628	3,168

REFRIGERANT CHARGE QUANTITY AND WEIGHTS WILL VARY BASED ON TUBE COUNT.  
Refer to product drawings for detailed weight information.

### 9.9.2 Evaporator Marine Water Box Weights

Add weights in table below to standard unit weights given in 9.9.2.

EVAP. CODE	SHIPPING WEIGHT INCREASE - KGS.			OPERATING WEIGHT INCREASE - KGS.		
	1-PASS	2-PASS	3-PASS	1-PASS	2-PASS	3-PASS
A	419	337	444	666	584	690
C,D	613	505	671	1,009	901	1,067
E,F	852	572	943	1,532	1,252	1,624
G,H	550	588	587	1,204	1,242	1,241
J,K,L	794	836	842	1,753	1,794	1,800
M,N	1,946	924	1,878	3,418	1,481	2,858
P,Q	2,115	1,021	2,107	3,514	1,581	3,353
R,S,W	2,179	1,225	2,228	3,866	2,048	3,714
X,Z	3,215	1,660	3,286	5,240	2,498	5,100

### 9.9.3 Condenser Marine Water Box Weights

Add weights in table below to standard unit weights given in 9.9.2.

COND. CODE	SHIPPING WEIGHT INCREASE - KGS.			OPERATING WEIGHT INCREASE - KGS.		
	1-PASS	2-PASS	3-PASS	1-PASS	2-PASS	3-PASS
A	346	257	367	578	489	600
C,D	429	353	474	767	691	813
E,F	329	368	359	606	781	772
J,K,L	467	529	522	1,047	1,110	1,103
M,N	1,119	603	1,054	2,206	1,110	2,078
P,Q	1,678	843	1,702	2,976	1,421	2,717
R,S	1,726	883	1,796	3,020	1,449	2,881
V,T,W	2,357	1,163	2,361	4,155	1,820	3,728
X,Z	2,649	1,339	2,440	4,491	2,109	3,674



### 9.10 Process and Instrumentation Diagram

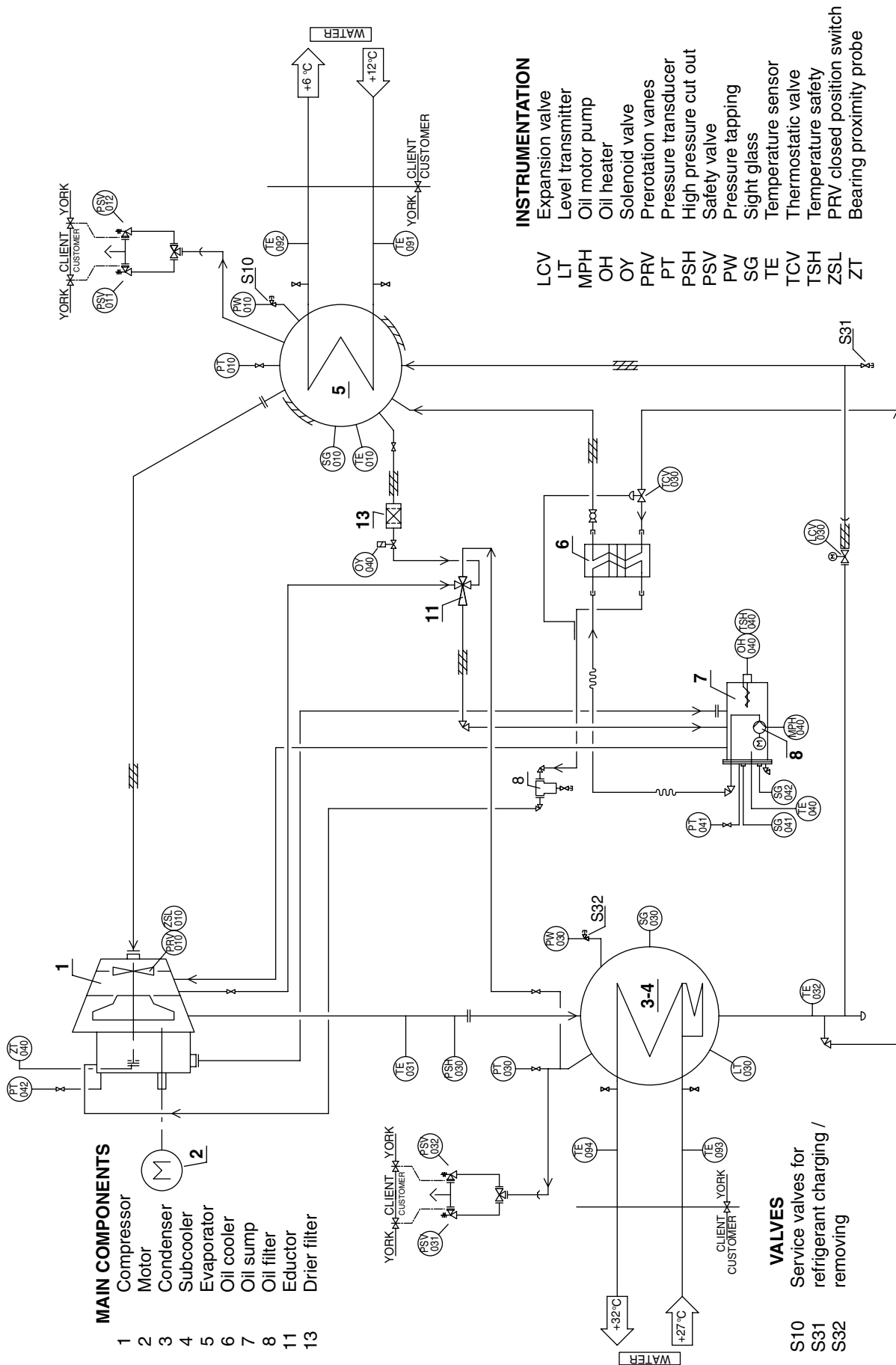

The P & I Diagram may vary according to the compressor and the options. This one is only an example based on a chiller with H5 compressor and without any options.

Page Left Intentionally Blank

## 10 SPARE PARTS

When ordering spare parts, we will require the following information to ensure the correct parts are supplied:

Full unit model number, serial number, application and details of the parts required.

All requests for parts should be made to your local York Sales and Service Centre.

Page Left Intentionally Blank

## 11 DE-COMMISSIONING, DISMANTLING AND DISPOSAL



**Never release refrigerant to the atmosphere when emptying the refrigerating circuits. Suitable retrieval equipment must be used. If reclaimed refrigerant cannot be re-used. It must be returned to the manufacturer.**

Packaged units can generally be removed in one piece after disconnection as above. Any fixing down bolts should be removed and then the unit should be lifted from position using the points provided and equipment of adequate lifting capacity.



**Never discard used compressor oil, as it contains refrigerant in solution. Return used oil to the oil manufacturer.**

Reference should be made to Section 4 for unit installation instructions, Section 9 for unit weights and Section 3 for handling.

Unless otherwise indicated the operations described below can be performed by any properly trained maintenance technician.

Units which cannot be removed in one piece, after disconnection as above, must be dismantled in position. Special care should be taken regarding the weight and handling of each component. Where possible units should be dismantled in the reverse order of installation.

### 11.1 General

Isolate all sources of electrical supply to the unit including any control system supplies switched by the unit. Ensure that all points of isolation are secured in the "OFF" position. The supply cables may then be disconnected and removed. For connection points refer to Section 4.

**Residual solution, refrigerant, oil and glycol or similar fluids may remain in some parts of the system. These should be mopped up and disposed of as described above.**

Remove all refrigerant from the unit into a suitable container using a refrigerant reclaim or recovery unit. This refrigerant may then be re-used, if appropriate, or returned to the manufacturer for disposal. Under NO circumstances should refrigerant be vented to atmosphere. Drain the oil from the unit into a suitable container and dispose of according to local laws and regulations governing the disposal of oily wastes. Any spilt oil should be mopped up and similarly disposed of.

It is important to ensure that whilst components are being removed the remaining parts are supported in a safe manner.



**Only use lifting equipment of adequate capacity.**

Isolate the unit heat exchangers from all external water systems and drain the heat exchanger sections of the system. If no isolation valves are installed it may be necessary to drain the complete systems.

After removal from position the unit parts may be disposed of according to local laws and regulations.



**If glycol or similar solutions have been used in the water system(s), or Chemical additives are contained, the solution MUST be disposed of in a suitable and safe manner. Under NO circumstances should any system containing glycol or similar solutions be drained directly into domestic waste or natural water systems.**

After draining, the water pipework can be disconnected and removed.

Page Left Intentionally Blank





[www.johnsoncontrols.com](http://www.johnsoncontrols.com)