

# YK - ALL MODELS

ENGINEERING GUIDE

Revision 0

Form 160.75-EG1.EN.CE/PED (1210)

## CENTRIFUGAL LIQUID CHILLER STYLE G (879 - 10,500 KW)

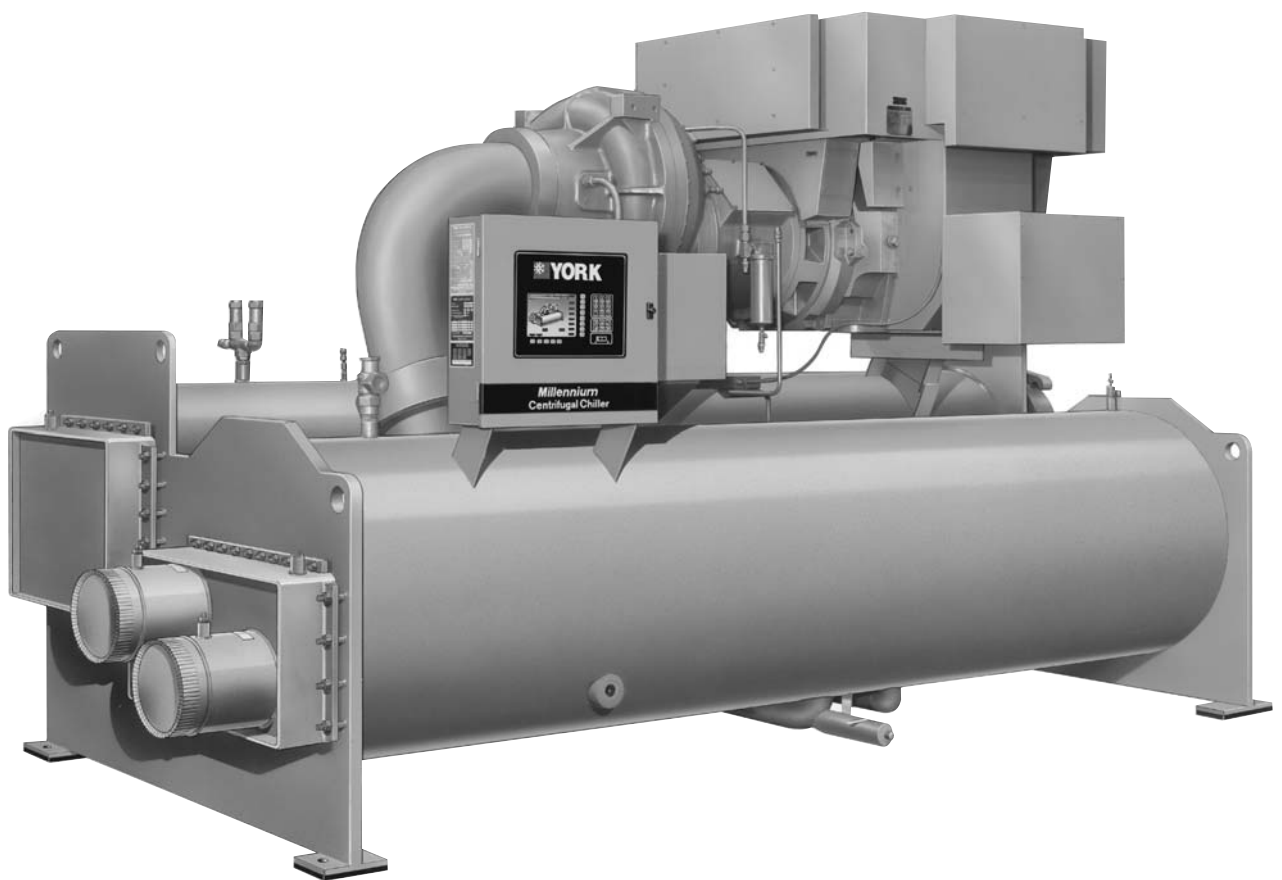

CE  
R134a

## TABLE OF CONTENTS

Introduction.....	3
Ratings .....	4
OptiView Control Center.....	5
Mechanical Specifications .....	8
Accessories and Modifications .....	12
Application Data .....	14
Dimensions (mm) - Unit .....	24
Dimensions (mm) - Nozzle Arrangements .....	27
Weights .....	38

## NOMENCLATURE

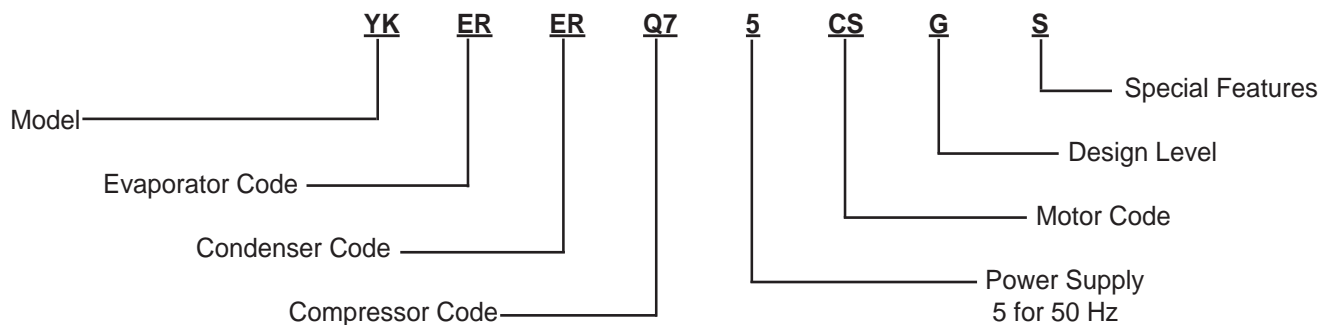

## INTRODUCTION

YORK **YK** Chillers offer a complete combination of features for total owner satisfaction.

### MATCHED COMPONENTS MAXIMIZE EFFICIENCY

Actual chiller efficiency cannot be determined by analyzing the theoretical efficiency of any one chiller component. It requires a specific combination of heat exchanger, compressor, and motor performance to achieve the lowest system kW/kW. YORK chiller technology matches chiller system components to provide maximum chiller efficiency under actual – not just theoretical – operating conditions.

### REAL-WORLD ENERGY PERFORMANCE

Johnson Controls pioneered the term “Real-World Energy” to illustrate the energy-saving potential of focusing on chiller performance during off-design conditions. Off-design is not only part load, but full load operation as well, with reduced entering condenser water temperatures (ECWTs). This is where chillers operate 99% of the time, and where operating costs add up.

The **YK** chillers are the only chillers designed to operate on a continuous basis with cold ECWT and full condenser flow at all load points, taking full advantage of Real-World conditions. This type of operation benefits the cooling tower as well; reducing cycling of the fan motor and ensuring good coverage of the cooling fill.

YORK **YK** chillers offer the most efficient Real-World operation of any chiller, meaning lower operating costs and an excellent return on your chiller investment.

### OPEN-DRIVE DESIGN

Hermetic motor burnout can cause catastrophic damage to a chiller. The entire chiller must be cleaned, and the refrigerant replaced. YORK **YK** centrifugal chillers eliminate this risk by utilizing air-cooled motors. Refrigerant never comes in contact with the motor, preventing contamination of the rest of the chiller.

Insurance companies that offer policies on large air conditioning equipment often consider air-cooled motors a significant advantage over hermetic refrigerant-cooled units.

### HIGH EFFICIENCY HEAT EXCHANGERS

**YK** chiller heat exchangers offer the latest technology in heat transfer surface design to give you maximum efficiency and compact design. Waterside and refrigerant side design enhancements minimize both energy consumption and tube fouling.

## SINGLE STAGE COMPRESSOR DESIGN AND EFFICIENCY PROVEN IN THE MOST DEMANDING APPLICATIONS

Designed to be the most reliable chillers we've ever made, YORK **YK** centrifugal chillers incorporate single-stage compressor design. With fewer moving parts and straightforward, efficient engineering, YORK single-stage compressors have proven durability records in hospitals, chemical plants, gas processing plants, the U.S. Navy, and in other applications where minimal downtime is a crucial concern.

In thousands of installations worldwide, YORK single-stage compressors are working to reduce energy costs. High strength aluminum-alloy compressor impellers feature backward curved vanes for high efficiency. Airfoil shaped pre rotation vanes minimize flow disruption for the most efficient part load performance. Precisely positioned and tightly fitted, they allow the compressor to unload smoothly from 100% to minimum load for excellent operation in air conditioning applications.

### PRECISION CONTROL OF COMPRESSOR OIL PRESSURE

Utilizing our expertise in variable speed drive technology and applications, Johnson Controls has moved beyond the fixed head and bypass approach of oil pressure control. The old approach only assures oil pressure at the outlet of the pump rather than at the compressor, and allows no adjustment during chiller operation. The **YK** chillers feature a variable speed drive oil pump, monitoring and providing the right amount of oil flow to the compressor on a continuous basis. This design also provides sophisticated electronic monitoring and protection of the oil pump electrical supply, ensuring long life and reliable operation of the oil pump motor. Variable speed drive technology reduces oil pump power consumption, running only at the speed required, rather than at full head with a pressure regulating bypass valve.

### FACTORY PACKAGING REDUCES FIELD LABOUR COSTS

YORK **YK** centrifugal chillers are designed to keep installation costs low. Where installation access is not a problem, the unit can be shipped completely packaged, requiring minimal piping and wiring to complete the installation.

For those units utilizing Variable Speed Drive or a factory-installed Solid-State Starter, the three power leads provide all power to the chiller and its auxiliaries.

## RATINGS

### TAKE ADVANTAGE OF COLDER COOLING TOWER WATER TEMPERATURES

YORK **YK** centrifugal chillers have been designed to take full advantage of colder cooling tower water temperatures, which are naturally available during most operating hours. Considerable energy savings are available by letting tower water temperature drop, rather than artificially holding it above 23.9°C, especially at low load, as some chillers require.

### SPECIFICATION

YK chillers are designed within EN ISO 9001 and built within an EN ISO 9002 accredited manufacturing organisation.

Chillers conform with the following European Directives:

- Machinery directive (2006/42/EC)
- EMC Directive (2004/108/EC)
- Pressure Equipment Directive (97/23/EC)
- Safety Code for Mechanical Refrigeration (EN378-2 (2008))

## COMPUTERIZED PERFORMANCE RATINGS

Each chiller is custom-matched to meet the individual building load and energy requirements. A variety of standard heat exchangers and pass arrangements are available to provide the best possible match.

It is not practical to provide tabulated performance for each combination, as the energy requirements at both full and part load vary significantly with each heat exchanger and pass arrangement. Computerized ratings are available through each Johnson Controls sales office. These ratings can be tailored to specific job requirements.

### OFF-DESIGN PERFORMANCE

Since the vast majority of its operating hours are spent at off-design conditions, a chiller should be chosen not only to meet the full load design, but also for its ability to perform efficiently at lower loads and lower tower water temperatures. It is not uncommon for chillers with the same full load kW to have an operating cost difference of over 10% due to part-load operation.

Part load information can be easily and accurately generated by use of the computer. And because it is so important to an owner's operating budget, this information has now been standardized.

A more detailed analysis must take into account actual building load profiles, and local weather data. Part load performance data should be obtained for each job using its own design criteria.

## OPTIVIEW CONTROL CENTER

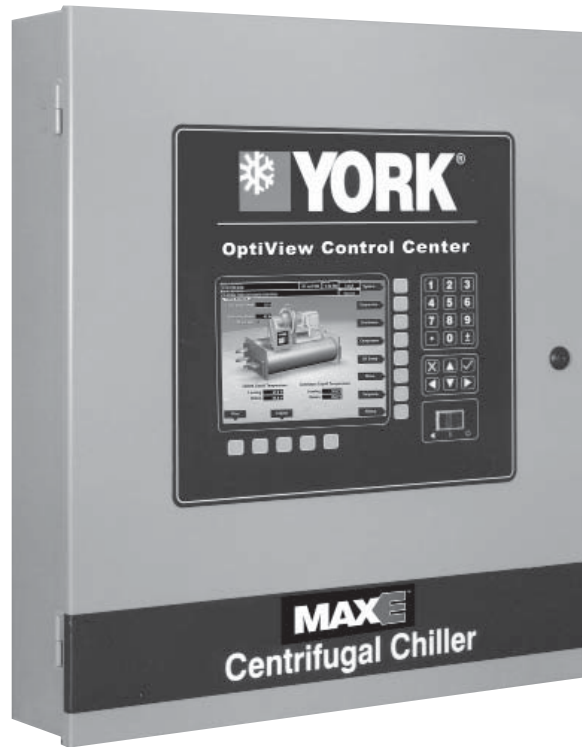

### YK OPTIVIEW CONTROL CENTER

The YORK OptiView™ Control Center, furnished as standard on each chiller, provides the ultimate in efficiency, monitoring, data recording, chiller protection and operating ease. The Control Center is a factory-mounted, wired and tested state-of-the-art microprocessor based control system for R134a centrifugal chillers. The panel is configured with a 10.4-in. (264 mm) diagonal color Liquid Crystal Display (LCD) surrounded by “soft” keys, which are redefined with one keystroke based on the screen displayed at that time. This revolutionary development makes chiller operation quicker and easier than ever before. Instead of requiring keystroke after keystroke to hunt for information on a small monochrome LCD screen, a single button reveals a wide array of information on a large, full-color illustration of the appropriate component, which makes information easier to interpret. This is all mounted in the middle of a keypad interface and installed in a locked enclosure.

The LCD display allows graphic animated display of the chiller, chiller sub-systems and system parameters; this allows the presentation of several operating parameters at once. In addition, the operator may view a graphical representation of the historical operation of the chiller as well as the present operation. A Status Bar is displayed at all times on all screens. It contains the System - Status Line and Details Line, the Control Source, Access Level, Time and Date.

During pre-lube and coast-down, the system status will include a countdown timer indicating the time remaining. The control panel is compatible with the YORK Solid-State Starter (optional); YORK Variable Speed Drive (VSD) (Optional); Electro-mechanical (E-M) starter or any customer supplied E-M starter that complies with the YORK R-1132 standard. The locations of various chiller parameters are clearly marked and instructions

the screens. The panel verbiage is available in eight languages as standard and can be changed on the fly without having to turn off the chiller. Data can be displayed in either English or Metric units plus keypad entry of setpoints to 0.1 increments.

Security access is provided to prevent unauthorized changes of setpoints. This is accomplished with three different levels of access and passwords for each level. There are certain screens, displayed values, **Programmable** setpoints and manual controls not shown that are for servicing the chiller. They are only displayed when logged in at service access level. Included in this is the Advanced Diagnostics and troubleshooting information for the chiller and the panel.

The panel is fused through a 1.5 or 2 KVA transformer in the compressor motor starter to provide individual over-current protected power for all controls. Numbered terminal strips for wiring such as Remote Start/Stop, Flow Switches, Chilled Water Pump and Local or Remote Cycling devices are provided. The Panel also provides field interlocks that indicate the chiller status. These contacts include a Remote Mode Ready-to-Start, a Cycling Shutdown, a Safety Shutdown and a chiller Run contact. Pressure transducers sense system pressures and thermistors sense system temperatures. The output of each transducer is a DC voltage that is analogous to the pressure input. The output of each thermistor is a DC voltage that is analogous to the temperature it is sensing.

Setpoints can be changed from a remote location via 0-10VDC, 4-20mA, contact closures or through serial communications. The adjustable remote reset range 11.1°C provides flexible, efficient use of remote signal depending on reset needs. Serial data interface to the Building Automation System (BAS) is through the optional microgateway, which can be mounted inside the Control Center.



This printed circuit board requests the required data from the microboard and makes it available for the Johnson Controls Metasys® network. This optional board is available through the Johnson Controls Building Efficiency group. The operating program is stored in non-volatile memory (EPROM) to eliminate chiller failure due to AC power failure/battery discharge. Programmed setpoints are retained in lithium battery-backed RTC memory for 10 years minimum.

Smart Freeze Point Protection will run the chiller at 2.2°C leaving chilled water temperature, and not permit nuisance trips on Low Water Temperature. The sophisticated program and sensor will monitor the chiller water temperature to prevent freeze up. Every **Programmable** point has a pop-up screen with the allowable ranges, so that the chiller cannot be programmed to operate outside of its design limits.

When the power is applied to the chiller, the HOME screen is displayed. This screen displays a visual representation of the chiller and a collection of data detailing important operations and parameters. When the chiller is running the flow of chilled liquid is animated by the alternating shades of color moving in and out of the pipe nozzles. The primary values that need to be monitored and controlled are shown on this screen.

With the “soft” keys the operator is only one touch away from the 8 main screens that allows access to the major information and components of the chiller. The 8 screens are the **SYSTEM, EVAPORATOR, CONDENSER, COMPRESSOR, OIL SUMP, MOTOR, SETPOINTS** and the **HISTORY**. Also on the Home screen is the ability to Log IN, Log Out and Print. Log In and Log Out is the means by which different security levels are accessed.

The **SYSTEM** screen gives a general overview of common chiller parameters for both shells. This is an end view of the chiller with a 3D cutaway of both the shells.

The **EVAPORATOR** screen displays a cutaway view of the chiller evaporator. All setpoints relating to the evaporator side of the chiller are maintained on this screen. Animation of the evaporation process indicates whether the chiller is presently in **RUN** condition (bubbling) and liquid flow in the pipes is indicated by alternating shades of color moving in and out of the pipes. Adjustable limits on the low water temperature setpoints allow the chiller to cycle on and off for greater efficiency and less chiller cycling. The chiller cycles off when the leaving chilled water temperature is below the setpoint and is adjustable from 0.55°C below to a minimum of 2.2°C. Restart is adjustable from the setpoint up to a max of 44.4°C. The panel will check for flow to avoid freeze up of the tubes. If flow is interrupted shutdown will occur after a minimum of two seconds.

The **CONDENSER** screen displays a cutaway view of the chiller condenser. The liquid flow is animated to indicate flow through the condenser. All setpoints relating to the condenser side of the chiller are maintained on this screen. With the proper access level, this screen also serves as a gateway to controlling the Refrigerant Level.

## HEAT RECOVERY

The **HEAT RECOVERY** screen displays a cutaway view of the chiller condenser. The liquid flow is animated to indicate flow when there is flow in either the lower tower bundle or upper heating bundle. All setpoints relating to the upper heating bundle are maintained on this screen.

The **COMPRESSOR** screen displays a cutaway view of the compressor; this reveals the impeller and shows all the conditions associated with the compressor. When the compressor impeller is spinning this indicates that the chiller is presently in **RUN** condition. With the proper access level, the pre-rotation vanes may be manually controlled. This screen also serves as a gateway to sub-screens for calibrating the pre-rotation vanes, the proximity probe, configuring the Hot Gas Bypass, or providing advanced control of the compressor motor Variable Speed Drive.

The **OIL SUMP** screen displays a close-up view of the chiller oil sump and provides all the necessary setpoints for maintaining the Variable Speed Oil Pump (VSOP). This screen also allows manual control of the frequency command sent to the VSOP.

The **MOTOR** “soft” key on the Home screen when pressed shows a picture of a YORK Electro-Mechanical Starter, Solid-State Starter or a Variable Speed Drive Screen depending on chiller configuration. Programmable pulldown demand to automatically limit motor loading for minimizing building demand charges is provided. Pulldown time period control over four hours, and verification of time remaining in pulldown cycle from display readout. Separate digital setpoint for current limiting between 30 and 100%.

The **ELECTRO-MECHANICAL STARTER – (E-M)** screen displays a picture of the starter and additional values.

The **SOLID STATE STARTER – (SSS)** screen displays a picture of the starter and additional values.

The **VARIABLE SPEED DRIVE - (VSD)** screen displays a picture of the VSD and additional values:

There are two additional screens (sub-screens) that have further VSD information.

The **SETPOINTS** screen provides a convenient location for programming the most common setpoints involved in the chiller control. The Setpoints are shown on other individual screens but to cut down on needless searching they are on this one screen. This screen also serves as a gateway to a sub-screen for defining the setup of general system parameters.

The **SETUP** is the top level of the general configuration parameters. It allows programming of the time and date, along with specifications as to how the time will be displayed. In addition, the chiller configuration as determined by the microboard program jumpers and program switches is displayed. From this screen you can perform the following:

The following 6 sub-screens can be accessed from the setup screen:

The **SCHEDULE** screen contains more programmable values than a normal display screen. Each programmable value is not linked to a specific button; instead the select key is used to enable the cursor arrows and check key to program the Start/Stop times for any day of the week up to 6 weeks in advance. The user has the ability to define a standard set of Start/Stop times that are utilized every week or specify exceptions to create a special week.

The **USER** screen allows definition of the language for the chiller to display and defines the unit of measure.

The **COMMS** screen allows definition of the necessary communications parameters.

The **PRINTER** screen allows Definition of the necessary communications Parameters for the printer.

The **SALES ORDER** screen allows definition of the order parameters.

The **OPERATIONS** screen allows definition of parameters related to the operation of the chiller. What is defined is whether the control of the chiller will be Local, Digital Remote, Analog Remote, Modem Remote or Metasys™ Remote.

The **HISTORY** screen allows the user to browse through the last ten faults; either safety or cycling shutdowns with the conditions while the chiller is running or stopped. The faults are color coded for ease in determining the severity at a glance, recording the date, time and description. (See Display Messages for Color Code meanings.)

By pressing the **VIEW DETAILS** key you will move to the **HISTORY DETAILS** screen. From these screens you are able to see an on-screen printout of all the system parameters at the time of the selected shutdown.

Also under the History screen is the **TRENDING** screen, accessible by the key marked the same. On this screen up to six operator-selected parameters, selected from a list of over 140, can be plotted in an X/Y graph format. The graph can be customized to record points once every second up to once every hour. There are two types of charts that can be created: a single or continuous screen. The single screen collects data for one screen width (450 data points across the x-axis) then stops. The continuous screen keeps collecting the data but the oldest data drops off the graph from left to right at the next data collection interval. For ease of identification, each plotted parameter, title and associated Y- axis labeling is color coordinated.

The **TREND SETUP** screen is used to configure the trending screen. The parameters to be trended are selected from the Trend Common Slots Screen accessed from the Slot #s button or the Master Slot Numbers List found in the operating manual. The interval at which all the parameters are sampled is selected under the Collection Interval button. The data point min. and max. values may be adjusted closer within the range to increase viewing resolution.

The **TREND COMMON SLOTS** screen displays the Master Slot Numbers List of the monitored parameters.

## DISPLAY MESSAGES

The Control Center continually monitors the operating system displaying and recording the cause of any shutdowns (Safety, Cycling or Normal). The condition of the chiller is displayed at the System Status line that contains a message describing the operating state of the chiller; whether it is stopped, running, starting or shutting down. A System Details line displays Warning, Cycling, Safety, Start Inhibit and other messages that provide further details of Status Bar messages. Messages are color-coded: Green – Normal Operations, Yellow - Warnings, Orange – Cycling Shutdowns, and Red – Safety Shutdowns to aid in identifying problems quickly.

## MECHANICAL SPECIFICATIONS

### GENERAL

The YORK YK Centrifugal Liquid Chillers are completely factory-packaged including the evaporator, condenser, compressor, motor, lubrication system, control center, and all interconnecting unit piping and wiring.

The initial charge of refrigerant and oil is supplied for each chiller. When the optional condenser isolation valves are ordered, most units may ship fully charged with refrigerant and oil. Actual shipping procedures will depend on a number of project-specific details.

The services of a Johnson Controls factory-trained, field service representative are incurred to supervise or perform the final leak testing, charging, the initial start-up, and concurrent operator instructions.

### COMPRESSOR

The compressor is a single stage centrifugal type powered by an open drive electric motor. The casing is fully accessible with vertical circular joints and fabricated of close grain cast iron. The complete operating assembly is removable from the compressor and scroll housing.

The rotor assembly consists of a heat treated alloy steel drive shaft and impeller shaft with a high strength, cast aluminum alloy, fully shrouded impeller. The impeller is designed for balanced thrust and is dynamically balanced and overspeed tested for smooth, vibration free operation.

The insert-type journal and thrust bearings are fabricated of aluminum alloy and are precision bored and axially grooved. The specially engineered, single helical gears with crowned teeth are designed so that more than one tooth is in contact at all times to provide even distribution of compressor load and quiet operation. Gears are assembled as part of the compressor rotor support and are film lubricated. Each gear is individually mounted in its own journal and thrust bearings to isolate it from impeller and motor forces.

### CAPACITY CONTROL

Pre-rotation vanes (PRV) modulate chiller capacity from 100% to 15% of design for normal air conditioning applications. Operation is by an external, electric PRV actuator which automatically controls the vane position to maintain a constant leaving chilled liquid temperature. Rugged airfoil-shaped, cast-manganese-bronze vanes are precisely positioned by solid vane linkages connected to the electric actuator.

### LUBRICATION SYSTEM

Lubrication oil is force-fed to all bearings, gears and rotating surfaces by a variable speed drive pump which operates prior to startup, continuously during operation and during coastdown. A gravity fed oil reservoir is built into the top of the compressor to provide lubrication during coastdown in the event of a power failure.

An oil reservoir, separate from the compressor, contains the submersible oil pump, 1.5 kW pump motor and 3000 watt immersion type oil heater. The oil heater is thermostatically controlled to remove refrigerant from the oil.

Oil is filtered by an externally mounted 1/2 micron replaceable cartridge oil filter equipped with service valves. Oil is cooled via a refrigerant-cooled oil cooler, eliminating the requirement for field water piping. The oil side of the oil cooler is provided with service valves. An automatic oil return system recovers any oil that may have migrated to the evaporator. Oil piping is completely factory-installed.

### WATER-COOLED OIL COOLER

Optional condenser water-cooled oil cooler is offered for units with Q3 compressors C-D shells only. This oil cooler is a shell and tube heat exchanger. Water from condenser supply waterbox circulates through the tube side of the heat exchanger and discharges back into the return side of the waterbox. Hot oil circulates through the tubes within the oil cooler, and is cooled by the cold condenser water. The cooled oil is then sent back to the compressor through a temperature regulator valve and oil filters. Both the oil and water piping are completely factory-installed, eliminating the requirement for field piping.

### MOTOR DRIVELINE

The compressor motor is an open drip proof, squirrel cage, induction type constructed to YORK design specifications.

The open motor is provided with a D flange, and is factory-mounted to a cast iron adaptor mounted on the compressor. This unique design allows the motor to be rigidly coupled to the compressor to provide factory alignment of motor and compressor shafts.

Motor drive shaft is directly connected to the compressor shaft with a flexible disc coupling. Coupling has all metal construction with no wearing parts to assure long life, and no lubrication requirements to provide low maintenance.

For units utilizing remote electro mechanical starters, a large, steel terminal box with gasketed front access cover is provided for field-connected conduit. There are six terminals (three for medium voltage) brought through the motor casing into the terminal box. Jumpers are furnished for three-lead types of starting. Motor terminal lugs are not furnished. Overload/over-current transformers are furnished with all units. For units furnished with factory-packaged Solid-State Starters or Variable Speed Drive, refer to the Accessories and Modifications Section.

### HEAT EXCHANGERS

#### Shells

Evaporator and condenser shells are fabricated from rolled carbon steel plates with fusion welded seams or carbon steel pipe. Carbon steel tube sheets, drilled and reamed to accommodate the tubes, are welded to the end of each shell. Intermediate tube supports are fabricated from carbon steel plates, drilled and reamed to eliminate sharp edges, and spaced no more than four feet apart. The refrigerant side of each shell is designed, tested, and stamped in accordance with the pressure vessel code as appropriate.



## Tubes

Heat exchanger tubes are state-of-the-art, high-efficiency, externally and internally enhanced type to provide optimum performance. Tubes in both the evaporator and condenser are 19 mm O.D. standard or 25.4 mm optional in some shells] copper alloy and utilize the "skip-fin" design, providing a smooth internal and external surface at each intermediate tube support. This provides extra wall thickness (up to twice as thick) and non work-hardened copper at the support location, extending the life of the heat exchangers. Each tube is roller expanded into the tube sheets providing a leak-proof seal, and is individually replaceable.

## Evaporator

The evaporator is a shell and tube, flooded type heat exchanger. A distributor trough provides uniform distribution of refrigerant over the entire shell length to yield optimum heat transfer. A suction baffle or aluminum mesh eliminators are located above the tube bundle to prevent liquid refrigerant carryover into the compressor. A 38 mm liquid level sight glass is conveniently located on the side of the shell to aid in determining proper refrigerant charge. The evaporator shell contains a dual refrigerant relief valve arrangement set at 12.4 barg on H and K Compressor models; 16.2 barg on P and Q Compressor models; or single-relief valve arrangement, if the chiller is supplied with the optional refrigerant isolation valves. A 25.4 mm refrigerant charging valve is provided.

## Condenser

The condenser is a shell and tube type, with a discharge gas baffle to prevent direct high velocity impingement on the tubes. The baffle is also used to distribute the refrigerant gas flow properly for most efficient heat transfer. An optional cast steel condenser inlet diffuser may be offered, on "M" and larger condensers, in lieu of the baffle, to provide dynamic pressure recovery and enhanced chiller efficiency. An integral sub cooler is located at the bottom of the condenser shell providing highly effective liquid refrigerant subcooling to provide the highest cycle efficiency. The condenser contains dual refrigerant relief valves set at 16.2 barg.

## Waterboxes

The removable waterboxes are fabricated of steel. The design working pressure is 10.3 barg and the boxes are tested at 15.5 barg. Integral steel water baffles are located and welded within the waterbox to provide the required pass arrangements. Water nozzle connections with grooves are welded to the water boxes. These nozzle connections are suitable couplings, welding or flanges, and are capped for shipment. Plugged 19 mm drain and vent connections are provided in each water box.

## WATER FLOW SWITCHES

Thermal type water flow switches are factory mounted in the chilled and condenser water nozzles, and are factory wired to the OptiView control panel. These solid state flow sensors have a small internal heating-element. They use the cooling effect of the flowing fluid to sense when an adequate flow rate has been established. The sealed sensor probe is 316 stainless steel, which is suited to very high working pressures.

## REFRIGERANT FLOW CONTROL

Refrigerant flow to the evaporator is controlled by the YORK variable orifice control system. Liquid refrigerant level is continuously monitored to provide optimum subcooler, condenser and evaporator performance. The variable orifice electronically adjusts to all Real-World operating conditions, providing the most efficient and reliable operation of refrigerant flow control.

## OPTIVIEW CONTROL CENTER

### General

The chiller is controlled by a stand-alone microprocessor based control center. The chiller control panel provides control of chiller operation and monitoring of chiller sensors, actuators, relays and switches.

### Control Panel

The control panel includes a 10.4-in. (264 mm) diagonal color liquid crystal display (LCD) surrounded by "soft" keys which are redefined based on the screen displayed at that time, mounted in the middle of a keypad interface and installed in a locked enclosure. The screen details all operations and parameters, using a graphical representation of the chiller and its major components. Panel verbiage is available in eight languages and can be changed on the fly without having to turn off the chiller. Data can be displayed in either English or Metric units. Smart Freeze Point Protection will run the chiller at 2.2°C leaving chilled water temperature, and not have nuisance trips on low water temperature. The sophisticated program and sensor monitors the chiller water temperature to prevent freeze-up. When needed, Hot Gas Bypass is available as an option. The panel displays countdown timer messages so the operator knows when functions are starting and stopping. Every programmable point has a pop-up screen with the allowable ranges, so that the chiller cannot be programmed to operate outside of its design limits.

The chiller control panel also provides:

1. System operating information including:
  - A. Return and leaving chilled water temperature
  - B. Return and leaving condenser water temperature
  - C. Evaporator and condenser saturation pressure
  - D. Differential oil pressure
  - E. Percent motor current
  - F. Evaporator and condenser saturation temperature
  - G. Compressor discharge temperature
  - H. Oil reservoir temperature
  - I. Compressor thrust bearing positioning (K compressors only)
  - J. Operating hours
  - K. Number of compressor starts

2. Digital programming of setpoints through the universal keypad including:

- A. Leaving chilled water temperature
- B. Percent current limit
- C. Pulls-down demand limiting
- D. Six-week schedule for starting and stopping the chiller, pumps and tower
- E. Remote reset temperature range

3. Status messages indicating:

- A. System ready to start
- B. System running
- C. System coastdown
- D. System safety shutdown – manual restart
- E. System cycling shutdown – auto restart
- F. System pre-lube
- G. Start inhibit

4. The text displayed within the system status and system details field is displayed as a color-coded message to indicate severity: red for safety fault, orange for cycling faults, yellow for warnings, and green for normal messages.

5. Safety shutdowns enunciated through the display and the status bar, and consist of system status, system details, day, time, cause of shutdown, and type of restart required. Safety shutdowns with a fixed-speed- drive include:

- A. Evaporator – low pressure
- B. Evaporator – transducer or leaving liquid probe
- C. Evaporator – transducer or temperature sensor
- D. Condenser – high pressure contacts open
- E. Condenser – high pressure
- F. Condenser – pressure transducer out-of-range
- G. Auxiliary safety – contacts closed
- H. Discharge – high temperature
- I. Discharge – low temperature
- J. Oil – high temperature
- K. Oil – low differential pressure
- L. Oil – high differential pressure
- M. Oil – sump pressure transducer out-of-range
- N. Oil – differential pressure calibration
- O. Oil – variable speed pump – pressure setpoint not achieved
- P. Control panel – power failure
- Q. Motor or starter – current imbalance

R. Thrust bearing – proximity probe clearance (K compressors only)

S. Thrust bearing – proximity probe out-of-range (K compressors only)

T. Thrust bearing – position switch (P, Q & H9 compressors)

U. Watchdog – software reboot

Safety shutdowns with a VSD include:

A. VSD shutdown – requesting fault data

B. VSD – stop contacts open

C. VSD – 105% motor current overload

D. VSD – high phase A, B, C inverter heat-sink temp.

E. VSD – high converter heat-sink temperature  
(Filter Option Only)

F. Harmonic filter – high heat-sink temperature

G. Harmonic filter – high total demand distortion

6. Cycling shutdowns enunciated through the display and the status bar, and consists of system status, system details, day, time, cause of shutdown, and type of restart required.

Cycling shutdowns with a fixed speed drive include:

A. Multi unit cycling – contacts open

B. System cycling – contacts open

C. Oil – low temperature differential

D. Oil – low temperature

E. Control panel – power failure

F. Leaving chilled liquid – low temperature

G. Leaving chilled liquid – flow switch open

H. Motor controller – contacts open

I. Motor controller – loss of current

J. Power fault

K. Control panel – schedule

L. Starter – low supply line voltage (SSS option)

M. Starter – high supply line voltage (SSS option)

N. Proximity probe – low supply voltage (K Compressor)

O. Oil – variable speed pump – drive contacts open

Cycling shutdowns with a VSD include:

A. VSD shutdown – requesting fault data

B. VSD – stop contacts open

C. VSD – initialization failed

D. VSD – high phase A, B, C instantaneous current

E. VSD – phase A, B, C gate driver

- F. VSD – single phase input power
  - G. VSD – high DC bus voltage
  - H. VSD – precharge DC bus voltage imbalance
  - I. VSD – high internal ambient temperature
  - J. VSD – invalid current scale selection
  - K. VSD – low phase A, B, C inverter heat-sink temp.
  - L. VSD – low converter heat-sink temperature
  - M. VSD – precharge – low DC bus voltage
  - N. VSD – logic board processor
  - O. VSD – run signal
  - P. VSD – serial communications (Filter Option Only)
  - Q. Harmonic filter – logic board or communications
  - R. Harmonic filter – high DC bus voltage
  - S. Harmonic filter – high phase A, B, C current
  - T. Harmonic filter – phase locked loop
  - U. Harmonic filter – precharge – low DC bus voltage
  - V. Harmonic filter – DC bus voltage imbalance
  - W. Harmonic filter – 110% input current overload
  - X. Harmonic filter – logic board power supply
  - Y. Harmonic filter – run signal
  - Z. Harmonic filter – DC current transformer 1
  - AA. Harmonic filter – DC current transformer 2
7. Security access to prevent unauthorized change of setpoints, to allow local or remote control of the chiller, and to allow manual operation of the pre-rotation vanes and oil pump. Access is through ID and password recognition, which is defined by three different levels of user competence: view, operator, and service.
  8. Trending data with the ability to customize points of once every second to once every hour. The panel will trend up to 6 different parameters from a list of over 140, without the need of an external monitoring system.
  9. The operating program stored in non-volatile memory (EPROM) to eliminate reprogramming the chiller due to AC power failure or battery discharge. Programmed setpoints are retained in lithium battery-backed RTC memory for a minimum of 10 years with power removed from the system.
  10. A fused connection through a transformer in the compressor motor starter to provide individual over-current protected power for all controls.
  11. A numbered terminal strip for all required field interlock wiring.
  12. An RS-232 port to output all system operating data, shutdown/cycling message, and a record of the last 10 cycling or safety shutdowns to a field-supplied

printer. Data logs to a printer at a set programmable interval. This data can be preprogrammed to print from 1 minute to 1 day.

13. The capability to interface with a building automation system via hard-wired connections to each feature to provide:

- A. Remote chiller start and stop
- B. Remote leaving chiller liquid temperature adjust
- C. Remote current limit setpoint adjust
- D. Remote ready to start contacts
- E. Safety shutdown contacts
- F. Cycling shutdown contacts
- G. Run contacts

## CODES AND STANDARDS

Chillers conform with the following European Directives:

- Machinery directive (2006/42/EC)
- EMC Directive (2004/108/EC)
- Pressure Equipment Directive (97/23/EC)
- Safety Code for Mechanical Refrigeration (EN378-2 (2008))

## ISOLATION MOUNTING

The unit is provided with four vibration isolation mounts of nominal 25mm operating height. The pads have a neoprene pad to contact the foundation, bonded to a steel plate. The vibration isolation pads assemblies mount under steel plates affixed to the chiller tube sheets.

## REFRIGERANT CONTAINMENT

The standard unit has been designed as a complete and compact factory-packaged chiller. As such, it has minimum joints from which refrigerant can leak. The entire assembly has been thoroughly leak tested at the factory prior to shipment. The YORK YK chiller includes service valves conveniently located to facilitate transfer of refrigerant to a remote refrigerant storage/recycling system. Optional condenser isolation valves allow storage of the charge in the condenser.

## PAINT

Exterior surfaces are protected with one coat of Caribbean blue, durable alkyd modified, vinyl enamel machinery paint.

## SHIPMENT

Protective covering is furnished on the motor starter, Control Center VSD and unit mounted controls. Water nozzles are capped with fitted plastic enclosures. Entire unit is protected with industrial-grade, reinforced shrink-wrapped covering.

## ACCESSORIES AND MODIFICATIONS

### OPTISPEED DRIVE

A 400V – 3-Ph – 50Hz variable speed drive is factory-packaged and mounted on the YORK **YK** chiller. It is designed to vary the compressor motor speed by controlling the frequency and voltage of the electrical power to the motor. The adaptive capacity control logic automatically adjusts motor speed and compressor pre-rotation vane position independently for maximum part load efficiency by analyzing information fed to it by sensors located throughout the chiller.

The variable speed drive is mounted in a IP54 enclosure with all power and control wiring between the drive and chiller factory-installed. Electrical lugs for incoming power wiring are provided.

The variable speed drive provides automatic power-factor correction to 0.95 or better at all load conditions. Separate power-factor correction capacitors are not required. The power-factor is 0.98 or better when the optional harmonic filter is provided.

Standard features include: a door interlocked lockable circuit breaker; ground fault protection; over-voltage and under-voltage protection; 3-phase sensing motor over-current protection; single-phase protection; insensitive to phase rotation; over-temperature protection; digital parameter readout at the OptiView Control Center.

An optional harmonic filter limits electrical power supply distortion from the variable speed drive

### SOLID-STATE STARTER

The Solid-State Starter is a reduced voltage starter that controls and maintains a constant current flow to the motor during startup. It is compact and mounted on the unit. Power and control wiring between the starter and the chiller are factory-installed. The starter enclosure is IP54, with a hinged access door with lock and key. Electrical lugs for incoming power wiring are provided.

Standard Features include digital readout of parameters at the OptiView Control Center

Other features include: low line voltage; 115-volt control transformer; three-leg, motor-current-sensing overloads; phase rotation and single-phase failure protection; high temperature safety protection; motor current imbalance and under-voltage safeties; open and shorted SCR protection; momentary power interruption protection. The Solid-State Starter is cooled by a closed-loop, fresh-water-circuit consisting of a water-to-water heat exchanger and a fractional horsepower circulating pump. All interconnecting water piping is factory-installed and rated for 10.3 barg working pressure. Optional electronic trip circuit breaker with integral ground fault protection is available with short circuit withstand ratings of:

65KA for 400V models

A non-fused disconnect switch is also available. Both options are lockable.

## QUICK START

The Quick Start feature is targeted towards data centers and process control applications where the goal is to re-establish process cooling as fast as possible after a power failure event. The Quick Start feature does this by reducing the time cycle for chiller restart and by loading the chiller as fast as possible, once running, to rapidly achieve the leaving chilled water temperature setpoint. The main objective is to provide minimum downtime and the fastest restart/loading as possible. Once the chiller is running and close to setpoint, it will return to standard YK control to minimize risk.

Quick Start Feature can be used with a UPS (supplied by others) or without a UPS. In order to start the most quickly, the OptiView control panel and VSD control circuit (except the trigger board) must be on a UPS. If a slightly longer restart time can be tolerated, the UPS is not required.

Depending on the compressor and the horsepower of the drive, a 3 kVA or 4 kVA UPS (supplied by others) with sine wave output is required to power the OptiView and required portions of the VSD control circuit.

Please refer to Form 160.75-TD4; Quick Start Feature for YK Mod G Chillers for additional information.

Quick Start Feature Availability - This feature applies only to YK chillers with Variable Speed Drives.

### BAS REMOTE CONTROL

A communication interface permitting complete exchange of chiller data with any BAS System is available with an optional Metasys™ translator. The Metasys™ translator also allows BAS System to issue commands to the chiller to control its operation. Metasys™ translators come in two models, controlling up to 4 chillers and 8 chillers respectively.

### FACTORY INSULATION OF EVAPORATOR

Factory-applied thermal insulation of the flexible, closed-cell plastic type, 19 mm thick is attached with vapor-proof cement to the evaporator shell, flow chamber, tube sheets, suction connection, and (as necessary) to the auxiliary tubing. Not included is the insulation of compact waterboxes and nozzles. This insulation will normally prevent condensation in environments with relative humidities up to 75% and dry bulb temperatures ranging from 10° to 32.2°C. 38 mm thick insulation is also available for relative humidities up to 90% and dry bulb temperatures ranging from 10° to 32.2°C.

### WATER FLANGES

Raised-face flanges for condenser and evaporator water connections are factory-welded to water nozzles. Companion flanges, bolts, nuts and gaskets are not included



## SPRING ISOLATION MOUNTING

Spring isolation mounting is available instead of standard isolation mounting pads when desired. Four level-adjusting, spring-type vibration isolator assemblies with non-skid pads are provided for field-installation. Isolators are designed for 25 mm deflection.

## SEQUENCE CONTROL KIT

For two, three or four units with chilled water circuits connected in series or parallel, the kit consists of return water thermostat, lead-lag selector switch for sequence starting, and time delay relay, with IP54 enclosures.

## STARTER - FIELD-INSTALLED

A field-installed, electro-mechanical compressor motor starter is available, selected for proper size and type for job requirements and in accordance with Johnson Controls Engineering Standard (R-1132) for Starters.

## MARINE WATERBOXES

Marine water boxes allow service access for cleaning of the heat exchanger tubes without the need to break the water piping. Bolted-on covers are arranged for convenient access. Nozzle connections are standard; flanges are optional. Marine water boxes are available for condenser and/or evaporator

## KNOCK-DOWN SHIPMENT

The chiller can be shipped knocked down into major subassemblies (evaporator, condenser, driveline, etc.) as required to rig into tight spaces. This is particularly convenient for existing buildings where equipment room access does not allow rigging a factory-packaged chiller.

## REFRIGERANT ISOLATION VALVES

Optional factory-installed isolation valves in the compressor discharge line and refrigerant liquid line are available. This allows isolation and storage of the refrigerant charge in the chiller condenser during servicing, eliminating time-consuming transfers to remote storage vessels. Both valves are positive shut-off, assuring integrity of the storage system.

## REFRIGERANT STORAGE/RECYCLING SYSTEM

A refrigerant storage/recycling system is a self-contained package consisting of a refrigerant compressor with oil separator, storage receiver, water-cooled condenser, filter drier and necessary valves and hoses to remove, replace and distill refrigerant. All necessary controls and safety devices are a permanent part of the system. A storage receiver is typically not required if optional unit isolation valves are provided.

## HIGH AMBIENT TEMPERATURE

Chiller modifications are available to allow for installation in high ambients 50°C. Special drive motors are required above 40°C. H9 and K compressor evaporator design pressures must be increased for ambient temperatures above 45°C. The OptiView panel and VSD are suited for 50°C ambient.

## OPTISOUND™ CONTROL

The YORK® OptiSound™ Control is a patented combination of centrifugal-chiller hardware and software that reduces operational sound levels, expands the chiller operating range, and improves chiller performance. The OptiSound Control feature continuously monitors the characteristics of the compressor-discharge gas and optimizes the diffuser spacing to minimize gas-flow disruptions from the impeller. This innovative technology improves operating sound levels of the chiller an average of 7 dBA, and up to 13 dBA on the largest models. It can also reduce part-load sound levels below the full-load level.

In addition, the OptiSound Control provides the benefit of an expanded operating range. It improves performance and reliability by minimizing diffuser-gas stall at off-design operation, particularly conditions of very low load combined with little or no condenser-water relief. The elimination of the gas-stall condition can also result in improved chiller efficiency at off-design conditions.

Johnson Controls recommends the OptiSound Control for chiller applications with elevated entering condenser-water temperatures (high-head) or applications requiring low-load operation with constant condenser temperature. At high-head conditions, improved chiller operation is visible at all load points.

### OptiSound Control Availability

Standard: Compressors P8, P9, H9, K1, K2, K3, K4, K7

Optional: Compressors Q3, Q4, Q5, Q6, Q7, P7



## APPLICATION DATA

The following discussion is a user's guide in the application and installation of YK chillers to ensure the reliable, trouble free life for which this equipment was designed. While this guide is directed towards normal, water chilling applications, the Johnson Controls sales representative can provide complete recommendations on other types of applications.

### LOCATION

YK chillers are virtually vibration free and may generally be located at any level in a building where the construction will support the total system operating weight.

The unit site must be a floor, mounting pad or foundation which is level within 6.4 mm and capable of supporting the operating weight of the unit.

Sufficient clearance to permit normal service and maintenance work should be provided all around and above the unit. Additional space should be provided at one end of the unit to permit cleaning of evaporator and condenser tubes as required. A doorway or other properly located opening may be used.

The chiller should be installed in an indoor location where temperatures range from 4.4°C to 40°C.

### WATER CIRCUITS

**Flow Rate** – For normal water chilling duty, evaporator and condenser flow rates are given in Table 1.

Variable flow in the condenser is not recommended, as it generally raises the energy consumption of the system by keeping the condenser pressure high in the chiller. Additionally, the rate of fouling in the condenser will increase at lower water velocities associated with variable flow, raising system maintenance costs. Cooling towers typically have narrow ranges of operation with respect to flow rates, and will be more effective with full design flow. Ref. Table 1 for flow limits at design conditions.

There is increasing interest to use variable primary flow (VPF) systems in large chilled water plants. VPF systems can offer lower installation and operating costs in many cases, but do require more sophisticated control and flow monitoring.

YORK YK Style G chillers will operate successfully in VPF systems. With a minimum allowable evaporator tube velocity of 0.5 m/s for standard tubes at part-load rating conditions, YK chillers will accommodate the wide variation in flow required by many chilled water VPF applications.

The chillers can tolerate a 50% flow rate change in one minute that is typically associated with the staging on or off of an additional chiller, however a lower flow rate change is normally used for better system stability and set point control. Proper sequencing via the building automation system will make this a very smooth transition.

**Temperature Ranges** – For normal water chilling duty, leaving chilled water temperatures may be selected between 3.3°C [2.2°C with Smart Freeze enabled] and 21.1°C for water temperature ranges between 1.7°C and 16.7°C.

**Water Quality** – The practical and economical application of liquid chillers requires that the quality of the water supply for the condenser and evaporator be analyzed by a water treatment specialist. Water quality may affect the performance of any chiller through corrosion, deposition of heat resistant scale, sedimentation or organic growth. These will degrade chiller performance and increase operating and maintenance costs. Normally, performance may be maintained by corrective water treatment and periodic cleaning of tubes. If water conditions exist which cannot be corrected by proper water treatment, it may be necessary to provide a larger allowance for fouling, and/or to specify special materials of construction.

**General Piping** – All chilled water and condenser water piping should be designed and installed in accordance with accepted piping practice. Chilled water and condenser water pumps should be located to discharge through the chiller to assure positive pressure and flow through the unit. Piping should include offsets to provide flexibility and should be arranged to prevent drainage of water from the evaporator and condenser when the pumps are shut off. Piping should be adequately supported and braced independently of the chiller to avoid the imposition of strain on chiller components. Hangers must allow for alignment of the pipe. Isolators in the piping and in the hangers are highly desirable in achieving sound and vibration control.

**Convenience Considerations** – To facilitate the performance of routine maintenance work, some or all of the following steps may be taken by the purchaser. Evaporator and condenser waterboxes are equipped with plugged vent and drain connections. If desired, vent and drain valves may be installed with or without piping to an open drain. Pressure gauges with stop cocks and stop valves may be installed in the inlets and outlets of the condenser and chilled water line as close as possible to the chiller. An overhead monorail or beam may be used to facilitate servicing.

**Connections** – The standard chiller is designed for 10.3 barg design working pressure in both the chilled water and condenser water circuits. The connections (water nozzles) to these circuits are furnished with grooves for grooved and shouldered joints. Piping should be arranged for ease of disassembly at the unit for tube cleaning. All water piping should be thoroughly cleaned of all dirt and debris before final connections are made to the chiller.

**TABLE 1 – WATER FLOW RATE LIMITS (L/S)**  
**— BASED UPON STANDARD TUBES @ DESIGN FULL LOAD CONDITIONS**

EVAPORATOR							CONDENSER						
MODEL	1 PASS		2 PASS		3 PASS		MODEL	1 PASS		2 PASS		3 PASS	
	MIN	MAX	MIN	MAX	MIN	MAX		MIN	MAX	MIN	MAX	MIN	MAX
AP	21	83	10	37	7	24	AP	30	109	15	54	10	36
AQ	25	102	13	45	8	29	AQ	39	139	19	67	13	46
AR	31	124	16	54	10	35	AR	43	155	22	74	14	51
AS	38	152	19	65	13	41	AS	49	175	24	82		
AC	44	178	22	75	15	52							
AD	56	223	28	91	19	64							
A3	43	170	21	85	14	57							
A4	51	205	26	102	17	68							
CP	41	164	20	73	14	48	CP	49	177	25	88	16	58
CQ	46	184	23	81	15	53	CQ	57	204	28	100	19	66
CR	55	218	27	95	18	63	CR	71	255	35	122	24	81
CS	66	263	33	113	22	74	CS	88	318	44	148		
CC	50	201	25	89	17	60							
CD	63	252	31	109	21	74							
CE	80	321	40	135	27	94							
C3	47	188	24	94	16	63							
C4	59	237	30	118	20	79							
C5	77	308	39	154	26	103							
DP	41	164	20	62	14	41	DP	49	177	25	76	16	50
DQ	46	184	23	70	15	46	DQ	57	204	28	87	19	57
DR	55	218	27	82	18	54	DR	71	255	35	106	24	70
DS	66	263	33	98	22	64	DS	88	318	44	129		
DC	50	201	25	77	17	51							
DD	63	252	31	95	21	64							
DE	80	321	40	118	27	80							
D3	47	188	24	92	16	62							
D4	59	237	30	114	20	77							
D5	77	308	39	143	26	100							
EP	54	217	27	97	18	64	EP	71	255	35	127	24	84
EQ	66	264	33	117	22	77	EQ	85	305	42	151	28	100
ER	78	311	39	137	26	90	ER	100	360	50	175	33	117
ES	92	366	46	159	31	105	ES	110	398	55	192	37	128
ET	106	423	53	181	35	120	ET	123	442	61	210		
EC	62	247	31	111	21	74							
ED	82	327	41	144	27	97							
EE	103	413	52	179	34	122							
E3	62	249	31	124	21	83							
E4	78	311	39	156	26	104							
E5	96	384	48	192	32	128							
FQ	66	264	33	100	22	66	FQ	85	305	42	130	28	86
FR	78	311	39	117	26	77	FR	100	360	50	152	33	101
FS	92	366	46	137	31	91	FS	110	398	55	166	37	111
FT	106	423	53	157	35	104	FT	123	442	61	183		
FC	62	247	31	95	21	63							
FD	82	327	41	124	27	83							
FE	103	413	52	155	34	104							
F3	62	249	31	123	21	82							
F4	78	311	39	152	26	102							
F5	96	384	48	184	32	125							
GQ	91	364	45	158	30	105	EV	100	360	50	175	33	117
GR	103	411	51	176	34	117	EW	110	398	55	192	37	128

Shaded areas indicate falling film evaporators. Refer to Table 5 for available compressor/shell/motor combinations.

**TABLE 1 – WATER FLOW RATE LIMITS (L/S)**

— BASED UPON STANDARD TUBES @ DESIGN FULL LOAD CONDITIONS - cont.

EVAPORATOR							CONDENSER						
MODEL	1 PASS		2 PASS		3 PASS		MODEL	1 PASS		2 PASS		3 PASS	
	MIN	MAX	MIN	MAX	MIN	MAX		MIN	MAX	MIN	MAX	MIN	MAX
GS	116	465	58	197	39	131	EX	123	442	61	210		
GC	82	326	41	144	27	97							
GD	102	408	51	177	34	120	E3	89	322	45	161	30	107
GE	133	532	66	222	44	155	E4	110	395	55	198		
G3	80	320	40	160	27	107							
G4	100	401	50	200	33	134							
G5	124	498	62	249	42	166							
HQ	91	364	45	136	30	90	FV	100	360	50	152	33	101
HR	103	411	51	153	34	101	FW	110	398	55	166	37	111
HS	116	465	58	171	39	113	FX	123	442	61	183		
HC	82	326	41	124	27	83							
HD	102	408	51	153	34	103	F3	89	322	45	161	30	107
HE	133	532	66	194	44	133	F4	110	395	55	198		
H3	80	320	40	156	27	105							
H4	100	401	50	191	33	131							
H5	124	498	62	229	42	161							
JP	97	390	49	173	32	114	JP	100	360	50	175	33	120
JQ	121	484	61	211	40	140	JQ	119	430	60	205	40	142
JR	151	605	76	259	50	173	JR	156	564	78	256	52	183
JS	165	660	83	279	55	188	JS	174	627	87	277		
KP,KT	97	390	49	159	32	105	KP	100	360	50	162	33	110
KQ,KV	121	484	61	195	40	129	KQ	119	430	60	190	40	131
KR,KW	151	605	76	240	50	160	KR	156	564	78	239	52	169
KS,KX	165	660	83	259	55	173	KS	174	627	87	260	0	0
K2,K5	116	465	58	233	39	155	K2	102	368	51	184	34	123
K3,K6	136	546	68	273	45	182	K3	122	438	61	219	41	146
K4,K7	157	628	78	309	52	209	K4	163	588	82	294		
KC	134	534	67	216	45	145							
KD	176	703	88	276	59	190							
K8	97	389	49	194	32	130							
K9	130	519	65	260	43	173							
K0	170	680	85	335	57	227							
LQ	121	484	61	182	40	121	LQ	119	430	60	178	40	122
LR	151	605	76	224	50	149	LR	156	564	78	225	52	158
LS	165	660	83	243	55	162	LS	174	627	87	245		
	0	0	0	0	0	0	MP	138	498	69	229	46	151
MQ	153	612	77	246	51	164	MQ	162	584	81	265	54	175
MR	179	714	89	284	59	191	MR	186	670	93	301	62	199
MS	205	819	102	321	68	217	MS	206	744	103	330		
M2	126	506	63	253	42	169	M2	134	484	67	242	45	161
M3	150	599	75	300	50	200	M3	166	600	83	300	56	200
M4	186	744	93	368	62	248	M4	205	738	102	369		
	0	0	0	0	0	0	NP	138	498	69	213	46	141
NQ	153	612	77	230	51	153	NQ	162	584	81	248	54	163
NR	179	714	89	265	59	178	NR	186	670	93	281	62	186
NS	205	819	102	300	68	203	NS	206	744	103	309		
N2	126	506	63	244	42	163	N2	134	484	67	242	45	161
N3	150	599	75	286	50	192	N3	166	600	83	300	56	200
N4	186	744	93	346	62	235	N4	205	738	102	369		
PQ	174	695	87	277	58	186	PQ	231	832	116	376	77	253
PR	198	790	99	311	66	210	PR	258	931	129	416	86	281
PS	212	848	106	331	71	224	PS	287	1033	143	455		

Shaded areas indicate falling film evaporators. Refer to Table 5 for available compressor/shell/motor combinations.

**TABLE 1 – WATER FLOW RATE LIMITS (L/S)**

— BASED UPON STANDARD TUBES @ DESIGN FULL LOAD CONDITIONS - cont.

EVAPORATOR							CONDENSER						
MODEL	1 PASS		2 PASS		3 PASS		MODEL	1 PASS		2 PASS		3 PASS	
	MIN	MAX	MIN	MAX	MIN	MAX		MIN	MAX	MIN	MAX	MIN	MAX
P2	159	637	80	318	53	212	P2	204	734	102	367	68	245
P3	187	747	93	370	62	249	P3	247	890	124	445	82	297
P4	212	847	106	410	71	282	P4	300	1082	150	541	100	361
QQ	174	695	87	259	58	173	QQ	231	832	116	351	77	235
QR	198	790	99	291	66	196	QR	258	931	129	389	86	262
QS	212	848	106	310	71	209	QS	287	1033	143	427		
Q2	159	637	80	302	53	203	Q2	204	734	102	367	68	245
Q3	187	747	93	347	62	236	Q3	247	890	124	445	82	297
Q4	212	847	106	386	71	265	Q4	300	1082	150	541		
QT	227	909	114	330	76	224							
QV	261	1045	131	372	87	255							
RQ	238	951	119	359	79	236	RQ	310	1116	155	469	103	310
RS	291	1162	145	433	97	285	RR	340	1225	170	510	113	338
RV	341	1364	171	501	114	331	RS	363	1308	181	541		
R3	244	977	122	467	81	307	R2	267	961	133	481	89	320
R5	290	1162	145	546	97	360	R3	315	1136	158	568	105	379
R7	331	1323	165	611	110	404	R4	373	1345	187	672		
RP	196	783	98	298	65	195							
RR	242	966	121	364	81	239							
RT	292	1169	146	435	97	287							
R2	240	959	120	459	80	302							
R4	271	1084	136	513	90	338							
R6	304	1215	152	568	101	375							
SQ	238	951	119	337	79	221	SQ	310	1116	155	441	103	292
SS	291	1162	145	407	97	268	SR	340	1225	170	481	113	318
SV	341	1364	171	472	114	311	SS	363	1308	181	510		
S3	244	977	122	440	81	289	S2	267	961	133	476	89	315
S5	290	1162	145	515	97	340	S3	315	1136	158	555	105	368
S7	331	1323	165	578	110	382	S4	373	1345	187	643		
							TP	340	1227	170	511	113	345
							TQ	377	1358	188	559	126	380
							TR	415	1495	207	607	138	415
							TS	437	1575	219	635		
							T2	291	1047	145	524	97	349
							T3	360	1298	180	649	120	433
							T4	397	1432	199	713	132	477
							T5	447	1613	224	784		
							VP	340	1227	170	481	113	324
							VQ	377	1358	188	527	126	357
							VR	415	1495	207	574	138	391
							VS	437	1575	219	600		
							V2	291	1047	145	514	97	347
							V3	360	1298	180	622	120	426
							V4	397	1432	199	677	132	467
							V5	447	1613	224	746		
WP	196	783	98	251	65	164	WQ	339	1220	169	432	113	290
WR	242	966	121	307	81	202	WR	372	1339	186	470	124	317
WT	292	1169	146	369	97	242	WS	405	1458	202	508		
W1	200	801	100	329	67	216	W1	268	966	134	428	89	286
W2	240	959	120	390	80	256	W2	332	1196	166	523	111	353
W4	271	1084	136	437	90	288	W3	387	1396	194	601	129	410
W6	304	1215	152	485	101	320	W4	428	1543	214	655		

**TABLE 1 – WATER FLOW RATE LIMITS (L/S)**

— BASED UPON STANDARD TUBES @ DESIGN FULL LOAD CONDITIONS - cont.

EVAPORATOR							CONDENSER						
MODEL	1 PASS		2 PASS		3 PASS		MODEL	1 PASS		2 PASS		3 PASS	
	MIN	MAX	MIN	MAX	MIN	MAX		MIN	MAX	MIN	MAX	MIN	MAX
XQ	301	1204	150	447	100	294	XQ	394	1419	197	595	131	396
XR	333	1330	166	490	111	323	XR	440	1584	220	657	146	438
XS	362	1449	181	529	121	349	XS	498	1796	249	734		
X2	301	1203	150	563	100	372	X2	313	1130	157	565	104	377
X3	356	1423	178	650	119	430	X3	409	1475	205	737	136	492
X4	396	1585	198	710	132	471	X4	511	1841	255	911		
ZQ	301	1204	150	421	100	277	ZQ	394	1419	197	560	131	372
ZR	333	1330	166	462	111	304	ZR	440	1584	220	619	146	412
ZS	362	1449	181	499	121	329	ZS	498	1796	249	693		
Z1	250	999	125	449	83	296	Z1	261	941	131	469	87	310
Z2	301	1203	150	532	100	351	Z2	313	1130	157	559	104	371
Z3	356	1423	178	615	119	407	Z3	409	1475	205	715	136	477
Z4	396	1585	198	673	132	446	Z4	511	1841	255	865		

**TABLE 1A - WATER FLOW RATE LIMITS (L/S) - BASED UPON STANDARD TUBES**

MODEL	HEAT RECOVERY CONDENSER - TOWER BUNDLE						HEAT RECOVERY CONDENSER - HEATING BUNDLE					
	1 PASS		2 PASS		3 PASS		1 PASS		2 PASS		3 PASS	
	MIN	MAX	MIN	MAX	MIN	MAX	MIN	MAX	MIN	MAX	MIN	MAX
BW	91	326	45	151	30	100	35	126	18	63	12	42
BX	91	326	45	151	30	100	54	196	27	96	18	64
IW	134	483	67	226	45	152	48	174	24	86	16	58
IX	134	483	67	226	45	152	85	305	42	143	28	100
OW	197	711	99	309	66	210	59	214	30	99	20	65
OX	197	711	99	309	66	210	125	451	63	198	42	133
O8	193	694	96	347	64	231	71	255	35	128	24	85
O9	193	694	96	347	64	231	113	407	57	204	38	136
UW	208	749	104	332	69	219	67	243	34	113	22	75
UX	208	749	104	332	69	219	132	475	66	215	44	144
U8	215	774	107	387	72	258	74	268	37	134	25	89
U9	215	774	107	387	72	258	119	430	60	215	40	143
YW	486	1752	243	677	162	452	164	590	82	240	55	159
YX	486	1752	243	677	162	452	310	1118	155	441	103	296
Y8	502	1810	251	841	167	565	204	736	102	368	68	245
Y9	502	1810	251	841	167	565	331	1192	165	586	110	397



**Chilled Water** – A water strainer of maximum 3.2 mm perforated holes must be field-installed in the chilled water inlet line as close as possible to the chiller. If located close enough to the chiller, the chilled water pump may be protected by the same strainer. The strainer is important to protect the chiller from debris or objects which could block flow through individual heat exchanger tubes. A reduction in flow through tubes could seriously impair the chiller performance or even result in tube freeze-up. A thermal-type flow switch is factory installed in the evaporator nozzle and connected to the OptiView panel, which assures adequate chilled water flow during operation.

**Condenser Water** – The chiller is engineered for maximum efficiency at both design and part load operation by taking advantage of the colder cooling tower water temperatures which naturally occur during the winter months. Appreciable power savings are realized from these reduced heads.

The minimum entering condenser water temperature for other full and part load conditions is provided by the following equation:

$$\text{Min. ECWT} = \text{LCHWT} - \text{C RANGE} + 2.8^{\circ}\text{C} + 6.6 \left( \frac{\% \text{Load}}{100} \right)$$

where:

ECWT = entering condensing water temperature

LCHWT = leaving chilled water temperature

C RANGE = condensing water temperature range at the given load condition.

At initial startup, entering condensing water temperature may be as much as 13.9°C colder than the standby chilled water temperature.

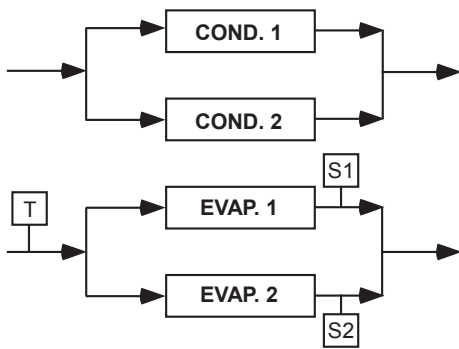

**S** – Temperature Sensor for Chiller Capacity Control

**T** – Thermostat for Chiller Capacity Control

**FIG. 1 – PARALLEL EVAPORATORS PARALLEL CONDENSERS**

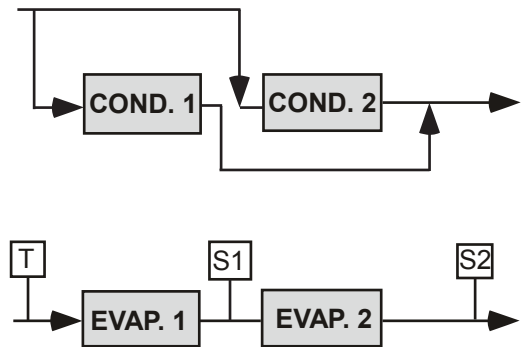

**S** – Temperature Sensor for Chiller Capacity Control

**T** – Thermostat for Chiller Capacity Control

**FIG. 2 – SERIES EVAPORATORS PARALLEL CONDENSERS**

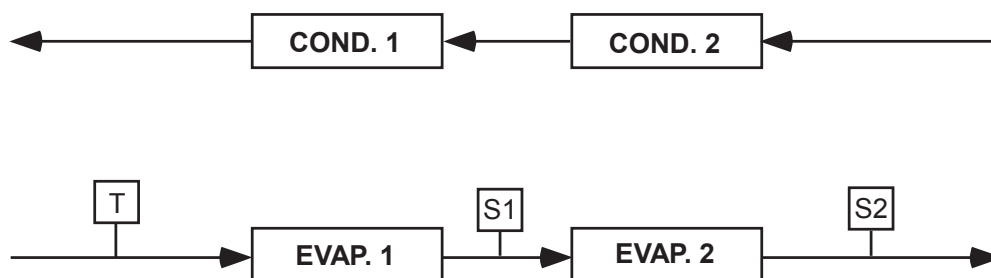

**FIG. 3 – SERIES EVAPORATORS SERIES-COUNTER FLOW CONDENSERS**

## MULTIPLE UNITS

**Selection** – Many applications require multiple units to meet the total capacity requirements as well as to provide flexibility and some degree of protection against equipment shutdown. There are several common unit arrangements for this type of application. The YK chiller has been designed to be readily adapted to the requirements of these various arrangements.

**Parallel Arrangement** (Refer to Fig. 1) – Chillers may be applied in multiples with chilled and condenser water circuits connected in parallel between the units. Fig. 1 represents a parallel arrangement with two chillers. Parallel chiller arrangements may consist of equally or unequally sized units. When multiple units are in operation, they will load and unload at equal percentages of design full load for the chiller.

Depending on the number of units and operating characteristics of the units, loading and unloading schemes should be designed to optimize the overall efficiency of the chiller plant. It is recommended to use an evaporator bypass piping arrangement to bypass fluid around evaporator of any unit which has cycled off at reduced load conditions. It is also recommended to alternate the chiller cycling order to equalize chiller starts and run hours.

**Series Arrangement** (Refer to Fig. 2) – Chillers may be applied in pairs with chilled water circuits connected in series and condenser water circuits connected in parallel. All of the chilled water flows through both evaporators with each unit handling approximately one half of the total load. When the load decreases to a customer selected load value, one of the units will be shut down by a sequence control. Since all water is flowing through the operating unit, that unit will cool the water to the desired temperature.

**Series Counter Flow Arrangement** (Refer to Fig. 3) - Chillers may be applied in pairs with chilled water circuits connected in series and with the condenser water in series counter flow. All of the chilled water flows through both evaporators. All of the condenser water flows through both condensers. The water ranges are split, which allows a lower temperature difference or "head" on each chiller, than multiple units in parallel. For equal chillers, the machine at higher temperature level will typically provide slightly more than half the capacity. The compressor motors and gear codes on the two chillers are often matched, such that the high temperature machine can operate at the low temperature conditions when one unit is cycled off at part loads (as compared to series-parallel chillers which are typically not identical).

Series counter flow application can provide a significant building energy savings for large capacity plants which have chilled and condenser water temperature ranges greater than typical ARI.

## HEAT RECOVERY

Heat recovery may be used in buildings, where there is a need for heating and cooling loads concurrently. By utilizing some or all of the heat rejection of a normal vapor-compression cycle cooling system, overall operating energy savings result. Heat recovery uses available heat as a byproduct of the cooling function, which differs from heat pumps where the heating can be considered the primary process. Also, the heat recovery usage is often a winter seasonal duty, where the chiller may be expected to operate in summer using heat rejection to a conventional cooling tower. As heating loops and cooling tower water circuits are separate in the majority of buildings, this dictates the need for two water circuits in the condenser of a heat recovery chiller.

Very simply, heat recovery allows you to utilize the heat, [which would otherwise be "wasted" (to the cooling tower)], to serve a useful purpose. This heat of rejection can be used to:

- Pre-heat domestic hot water needs like in hotels or hospitals for use in:
- Laundry, Showers, Swimming pools, Cooking/ Dishwashing, Hot tub
- Comfort Heating (Perimeter heating)
- Reheating of air
- Preheating of boiler makeup water or process hot water.

The main difference between a cooling only chiller and a heat recovery chiller is in the heat recovery chiller's added ability to reject the "free condenser heat" to the cooling tower and/or the heating system. Since heat is being removed from the area to be cooled, the cooling load supports the heating load. There must be a simultaneous cooling and heating load in the building.

When using a Solid State Starter or Variable Speed Drive for a heat recovery application, the starters will be chilled water cooled.

Please refer to Form 160.75-AD2; YK Mod G Heat Recovery Application Data for additional information.

Heat Recovery Availability

Standard: Compressors Q4, Q7, H9, K2, K7

## REFRIGERANT RELIEF PIPING

Each chiller is equipped with dual pressure relief valves on the condenser and two dual relief valves on the evaporator, or two single relief valves on the evaporator if the optional refrigerant isolation valves are ordered. The dual relief valves on the condenser are redundant and allow changing of either valve while the unit is fully charged. The purpose of the relief valves is to quickly relieve excess pressure of the refrigerant charge to the atmosphere, as a safety precaution in the event of an emergency such as fire.

Sized to the requirements of applicable codes, a vent line must run from the relief device to the outside of the building. This refrigerant relief piping must include a cleanable, vertical leg dirt trap to catch vent stack condensation. Vent piping must be arranged to avoid imposing a strain on the relief connection and should include one flexible connection.

## SOUND AND VIBRATION CONSIDERATIONS

A YK chiller is not a source of objectionable sound and vibration in normal air conditioning applications. Neoprene isolation mounts are furnished as standard with each unit. Optional level adjusting spring isolator assemblies designed for 25 mm static deflection are available from Johnson Controls.

YK chiller sound pressure level ratings will be furnished on request.

Control of sound and vibration transmission must be taken into account in the equipment room construction as well as in the selection and installation of the equipment.

## ELECTRICAL CONSIDERATIONS

Unit input conductor size must be in accordance with the local or other applicable codes, for the unit full load amperes (FLA). Refer to the submittal drawings for the FLA and Minimum Current.

Ampacity (MCA) specific to each application. Flexible conduit should be used for the last several feet to the chiller in order to provide vibration isolation. The table below lists the allowable variation in voltage supplied to the chiller. The unit nameplate is stamped with the unit voltage, and frequency.

FREQ.	RATED VOLTAGE	NAME-PLATE VOLTAGE	OPERATING VOLTAGE	
			MIN.	MAX.
50 HZ	400	380/400/415	342	423
	415	415	374	456

**Starters** – A separate starter is not required since the YORK YK chiller is equipped with a factory installed unit mounted Variable Speed Drive (VSD).

**Controls** – No field control wiring is required since the Optispeed Variable Speed Drive is factory installed as standard. The chiller including VSD is completely controlled by the control panel.

**Copper Conductors** – Only copper conductors should be connected to compressor motors and starters. Aluminium conductors have proven to be unsatisfactory

when connected to copper lugs. Aluminium oxide and the difference in thermal conductivity between copper and aluminium cannot guarantee the required tight connection over a long period of time.

**Power-factor Correction Capacitors** – The YORK YK is equipped with a factory mounted Optispeed VSD providing automatic power-factor correction to a minimum of 0.97 at all operating conditions, so additional capacitors are not required.

**Branch Circuit Overcurrent Protection** – The branch circuit overcurrent protection device(s) should be a time-delay type, with a minimum rating equal to the next standard fuse/breaker rating above the calculated value. Refer to submittal drawings for the specific calculations for each application.

## THERMAL INSULATION

No appreciable operating economy can be achieved by thermally insulating the chiller. However, the chiller's cold surfaces should be insulated with vapor barrier insulation sufficient to prevent condensation. A chiller can be factory-insulated with 19 mm or 38 mm thick insulation, as an option. This insulation will normally prevent condensation in environments with dry bulb temperatures of 10°C to 32°C and relative humidities up to 75% (19 mm thickness) or 90% (38 mm thickness). The insulation is painted and the surface is flexible and reasonably resistant to wear. It is intended for a chiller installed indoors and, therefore, no protective covering of the insulation is usually required. If insulation is applied to the waterboxes at the job site, it must be removable to permit access to the tubes for routine maintenance.

## MOTOR ELECTRICAL DATA

The smallest motor available which equals or exceeds the Input power (kW) from the chiller rating program is selected from Tables 2 and 3. The full load amperes (FLA) listed in the tables is maximum values and corresponds to the maximum motor kW listed. When the input power (kW) is less than maximum motor kW, the FLA should be reduced per the following equation:

$$FLA = \frac{\text{Motor kW} \times \text{Max. Motor FLA}}{\text{Max. Motor kW}}$$

The benefit from the FLA correction is the possible use of smaller power wiring and/or starter size.

The locked rotor amperes (LRA) are read directly from Tables 3 and 4 for specific Motor Code and voltage. This is because the LRA is dependent only on motor size and voltage and is independent of input power (kW).

Inrush amperes (IRA) depend on LRA and the type of starter applied. The inrush can be calculated using a percentage of LRA shown in Table 3.

**TABLE 2 – VARIABLE SPEED DRIVE SIZES**

Hz	MOTOR VOLTAGE	JOB MAX HP
50	400	292
		419
		658
		917

**TABLE 3 – 50 Hz ELECTRICAL DATA**

MOTOR CODE	5CC	5CD	5CE	5CF	5CG	5CH	5CI	5CJ	5CK	5CL	5CM	5CN	5CO	5CP	5CQ	5CR	5CS	
KW (MAX)	121	136	160	180	201	215	231	254	280	309	332	366	402	432	455	481	518	
SHAFT HP	148	168	198	225	252	272	292	321	353	390	419	462	507	546	575	608	658	
FL EFF.-%	91.1	92.4	92.4	93.4	93.4	94.2	94.2	94.2	94.2	94.2	94.2	94.2	94.2	94.2	94.2	94.2	94.7	
FL PF	0.9	0.9	0.9	0.9	0.9	0.9	0.9	0.9	0.9	0.9	0.9	0.9	0.9	0.9	0.9	0.9	0.9	
VOLTS		AMPERES (MAX.)																
380	FLA	204	235	275	309	346	379	398	438	481	532	572	630	690	743	783	841	895
	LRA	1,385	1,385	1,640	1,890	2,144	2,464	2,590	2,806	3,050	3,375	3,700	3,810	4,400	4,500	4,892	5,600	5,491
400	FLA	194	223	261	294	329	360	378	416	457	505	543	599	656	706	744	799	850
	LRA	1,458	1,458	1,726	1,990	2,257	2,594	2,726	2,954	3,211	3,553	3,895	4,011	4,632	4,737	5,149	5,895	5,780
415	FLA	187	215	252	284	317	347	364	401	441	487	526	577	632	680	717	764	819
	LRA	1,283	1,385	1,490	1,700	2,031	2,175	2,366	2,569	2,794	3,088	3,402	3,478	3,810	4,117	4,480	5,130	5,108

MOTOR CODE	5CT	5CU	5CV	5CW	5CX	5DA	5DB	
KW (MAX)	554	591	630	669	709	785	863	
SHAFT HP	704	750	800	850	900	1,000	1,100	
FL EFF.-%	94.7	94.7	94.7	94.7	94.7	95	95	
FL PF	0.9	0.9	0.9	0.9	0.9	0.9	0.9	
VOLTS		AMPERES (MAX.)						
380	FLA	957	1,008	1,075	1,143	1,210	1,355	1,508
	LRA	5,491	6,313	6,694	7,113	7,404	7,794	8,511
400	FLA	909	958	1,021	1,086	1,150	1,287	1,433
	LRA	5,780	6,645	7,046	7,487	7,794	8,204	8,959
415	FLA	876	923	985	1,046	1,108	1,241	1,381
	LRA	5,512	5,780	6,131	6,513	6,938	7,138	7,794

**TABLE 4 – MOTOR STARTERS**

TYPE STARTER	SOLID STATE STARTER	STAR DELTA	AUTO TRANSFORMER			ACROSS-THE-LINE	PRIMARY REACTOR	
VOLTAGE	LOW/MEDIUM	LOW	LOW	LOW/MEDIUM	LOW/MEDIUM	LOW/MEDIUM	MEDIUM	MEDIUM
50 HZ	380-3300	346-415	346-415	346-3300	346-3300	346-3300	2300-3300	2300-3300
TRANSITION %	—	CLOSED	CLOSED	CLOSED	CLOSED	—	CLOSED	CLOSED
TAP INRUSH AS A % OF LRA	—	—	57.7	65	80	—	65	80
	45	33	33	42.3	64	100	65	80

**NOTE:** Inrush less than 100% of full load amps (FLA).

TABLE 5 – AVAILABLE COMPRESSOR/SHELL/MOTOR COMBINATIONS

<b>YK MOD G COMBINATIONS</b>			
<b>COMPRESSOR CODES</b>	<b>EVAPORATOR CODES</b>	<b>CONDENSER CODES</b>	<b>MOTOR CODES</b>
			<b>50 HZ</b>
<b>Q3</b>	AP TO AS	AP TO AS	5CC-5CO
<b>Q3, Q4</b>	CP TO CS	CP TO CS	
	DP TO DS	DP TO DS	
<b>Q4</b>	EP TO ET	EP TO ET	5CE-5CO
<b>Q5</b>	CP TO CS	CP TO CS	
	DP TO DS	DP TO DS	
<b>Q5, Q6, Q7</b>	EP TO ET	EP TO ET	5CP-5CU
	FQ TO FT	FQ TO FT	
<b>P7</b>	EP TO ET	EP TO ET	5CE-5CU
<b>P8</b>	FQ TO FT	FQ TO FT	
	<b>P8, P9</b>	GQ TO GS	EV TO EX
HQ TO HS		FV TO FX	
JP TO JS		JP TO JS	
LQ TO LS		LQ TO LS	
<b>H9</b>	KP TO KS, K2 TO K4	KP TO KS, K2 TO K4	5CN-5DC
	MQ TO MS, M2 TO M4	MP TO MS, M2 TO M4	
<b>K1, K2</b>	KT TO KX, K5 TO K7	KP TO KS, K2 TO K4	5DA-5DH
	MQ TO MS, M2 TO M4	MP TO MS, M2 TO M4	
	NQ TO NS, N2 TO N4	NP TO NS, N2 TO N4	
	PQ TO PS, P2 TO P4	PQ TO PS, P2 TO P4	
	QQ TO QS, Q2 TO Q4	QQ TO QS, Q2 TO Q4	
<b>K3</b>	NQ TO NS, N2 TO N4	NP TO NS, N2 TO N4	5DA-5DJ
	QQ TO QV, Q2 TO Q4	QQ TO QS, Q2 TO Q4	
	RQ, RS, RV, R3, R5, R7	RQ TO RS, R2 TO R4	
<b>K4</b>	RP, RR, RT, R2, R4, R6	RQ TO RS, R2 TO R4	5DD-5DL
	SQ, SS, SV, S3, S5, S7	SQ TO SS, S2 TO S4	
		VP TO VS, V2 TO V5	
	XQ TO XS, X2 TO X4	TP TO TS, T2 TO T5	
<b>K7</b>	WP-WT, W1, W2, W4, W6	WQ TO WS, W1 TO W4	5DD-5DL
	ZQ TO ZS, Z1 TO Z4	ZQ TO ZS, Z1 TO Z4	

**YK MOD G HEAT RECOVERY COMBINATIONS**

<b>COMPRESSOR CODES</b>	<b>EVAPORATOR CODES</b>	<b>CONDENSER CODES</b>	<b>MOTOR CODES</b>
			<b>50 HZ</b>
<b>Q4</b>	CP TO CS	BW, BX	5CC-5CO
<b>Q7</b>	EP TO ET	IW, IX	
<b>H9</b>	KP TO KS, K2 TO K4	OW, OX, O8, O9	5CK-5CW
<b>K2</b>	MQ TO MS, M2 TO M4	UW, UX, U8, U9	5CN-5DC
<b>K7</b>	ZQ TO ZS, Z1 TO Z4	YW, YX, Y8, Y9	5DD-5DL

**YK MOD G HYBRID FALLING FILM COMBINATIONS**

<b>COMPRESSOR CODES</b>	<b>HYBRID FALLING FILM EVAPORATOR CODES</b>	<b>CONDENSER CODES</b>	<b>MOTOR CODES</b>
			<b>50 HZ</b>
<b>Q3</b>	AC, AD, A3, A4	AP TO AS	5CC-5CO
	CC TO CE, C3 TO C5	CP TO CS	
<b>Q4</b>	CC TO CE, C3 TO C5	CP TO CS	
	DC TO DE, D3 TO D5	DP TO DS	
<b>Q5</b>	CC TO CE, C3 TO C5	CP TO CS	5CE-5CO
	DC TO DE, D3 TO D5	DP TO DS	
<b>Q5, Q6, Q7</b>	EC TO EE, D3 TO E5	EP TO ET	
	FC TO FE, F3 TO F5	FQ TO FT	
<b>P7</b>	EC TO EE, D3 TO E5	EP TO ET	5CP-5CU
	FC TO FE, F3 TO F5	FQ TO FT	
<b>P8, P9</b>	GC TO GE, G3 TO G5	EV TO EX, E3 TO E4	5CE-5CU
	HC TO HE, H3 TO H5	FV TO FX, F3 TO F4	
<b>H9</b>	KC, KD, K8, K9, K0	KP TO KS, K2 TO K4	5CK-5CW



# DIMENSIONS (MM) - UNIT

## P & Q COMPRESSOR UNITS

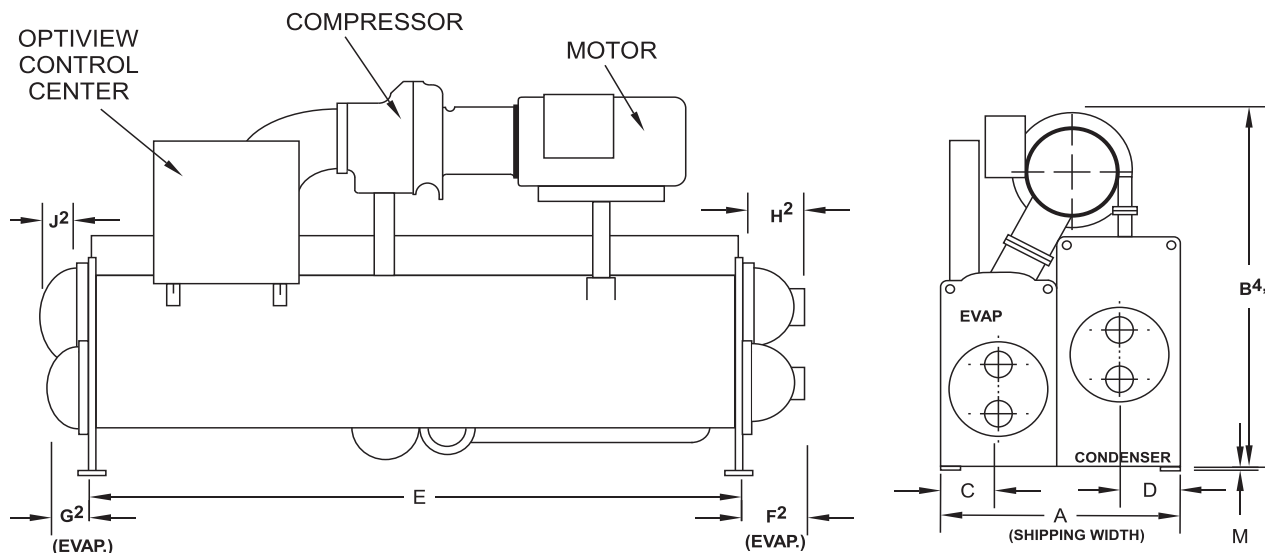

ADDITIONAL OPERATING HEIGHT CLEARANCE TO FLOOR	
TYPE OF CHILLER MOUNTING	M
NEOPRENE PAD ISOLATORS	45
SPRING ISOLATORS 1" DEFLECTION	25
DIRECT MOUNT	19

Q3 COMPRESSOR			
EVAPORATOR-CONDENSER SHELL CODES			
	A-A	C-C	D-D
A	1549	1676	1676
B	2134	2229	2229
C	394	445	445
D	381	394	394
E	3658	3658	4877

P7, Q7 COMPRESSOR			
EVAPORATOR-CONDENSER SHELL CODES			
	E-E	E-I	F-F
A	1880	2178	1880
B	2454	2642	2454
C	495	495	495
D	445	594	445
E	3658	3658	4877

Q4 COMPRESSOR				
EVAPORATOR-CONDENSER SHELL CODE				
	C-B	C-C	D-D	E-E
A	1949	1676	1676	2134
B	2423	2197	2197	2350
C	445	445	445	495
D	530	394	394	445
E	3658	3658	4877	3658

P8 COMPRESSOR				
EVAPORATOR-CONDENSER SHELL CODES				
	G-E	H-F	J-J	L-L
A	2108	2108	2299	2299
B	3200	3200	3327	3327
C	610	610	641	641
D	445	445	508	508
E	3658	4877	3658	4877

Q5 COMPRESSOR				
EVAPORATOR-CONDENSER SHELL CODES				
	C-C	D-D	E-E	F-F
A	1676	1676	2134	2134
B	2403	2403	2578	2578
C	445	445	495	495
D	394	394	445	445
E	3658	4877	3658	4877

P9 COMPRESSOR			
EVAPORATOR-CONDENSER SHELL CODES			
	H-F	J-J	L-L
A	2108	2299	2299
B	3124	3264	3264
C	610	641	641
D	445	508	508
E	4877	3658	4877

Q6 COMPRESSOR		
EVAPORATOR-CONDENSER SHELL CODES		
	E-E	F-F
A	2134	2134
B	2515	2515
C	495	495
D	445	445
E	3658	4877

**DIMENSIONS (MM) - UNIT**

**H COMPRESSOR UNITS**

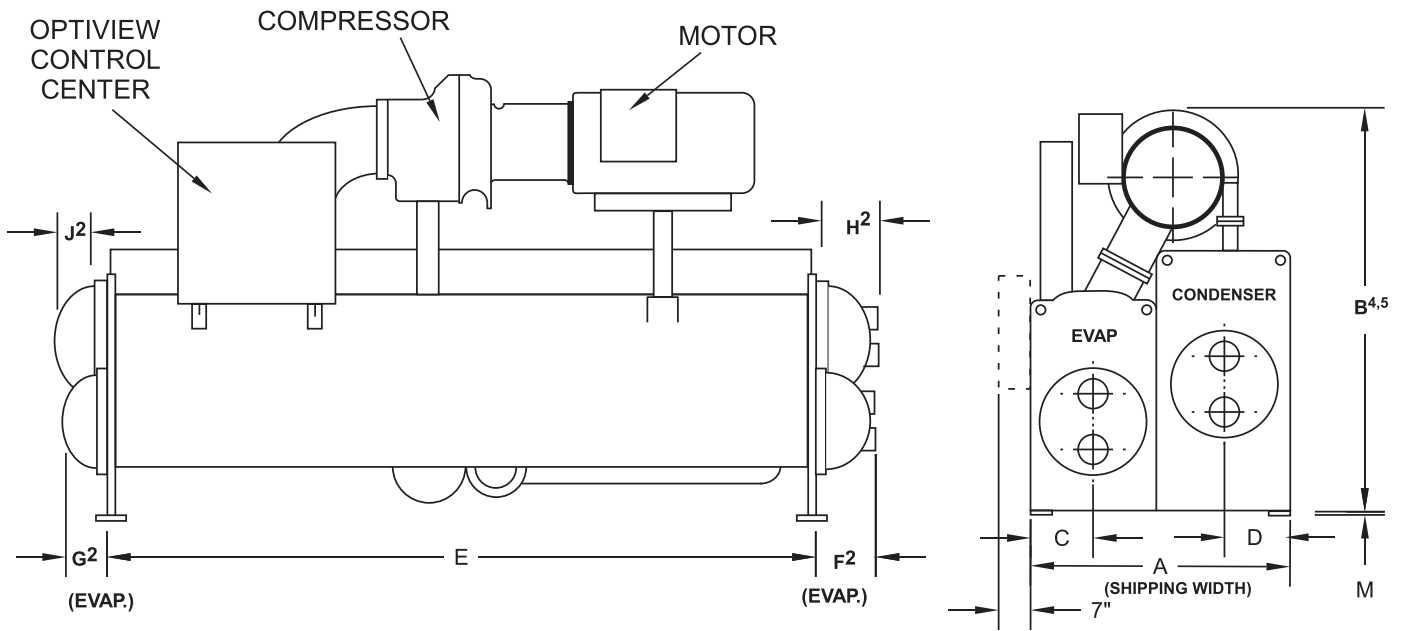

ADDITIONAL OPERATING HEIGHT CLEARANCE	
TYPE OF CHILLER MOUNTING	M
NEOPRENE PAD ISOLATORS	44
SPRING ISOLATORS 25MM DEFLECTION	25
DIRECT MOUNT	19

H9 COMPRESSORS			
EVAP.-COND. SHELL CODES			
	K-K	K-O	M-M
A	2299	2673	2616
B	3150	3242	3315
C	641	641	724
D	508	695	584
E	4267	4267	4267

**NOTES:**

1. All dimensions are approximate. Certified dimensions are available on request.
2. For all waterboxes (compact shown above), determine overall unit length by adding waterbox depth to tube sheet length.
3. Water nozzles can be located on either end of unit. Add 13 mm to nozzle length for flanged connections.
4. To determine overall height, add dimension "M" for the appropriate isolator type.
5. Use of motors with motor hoods may increase overall unit dimensions.

**DIMENSIONS (MM) – UNIT**

**K COMPRESSOR UNITS**

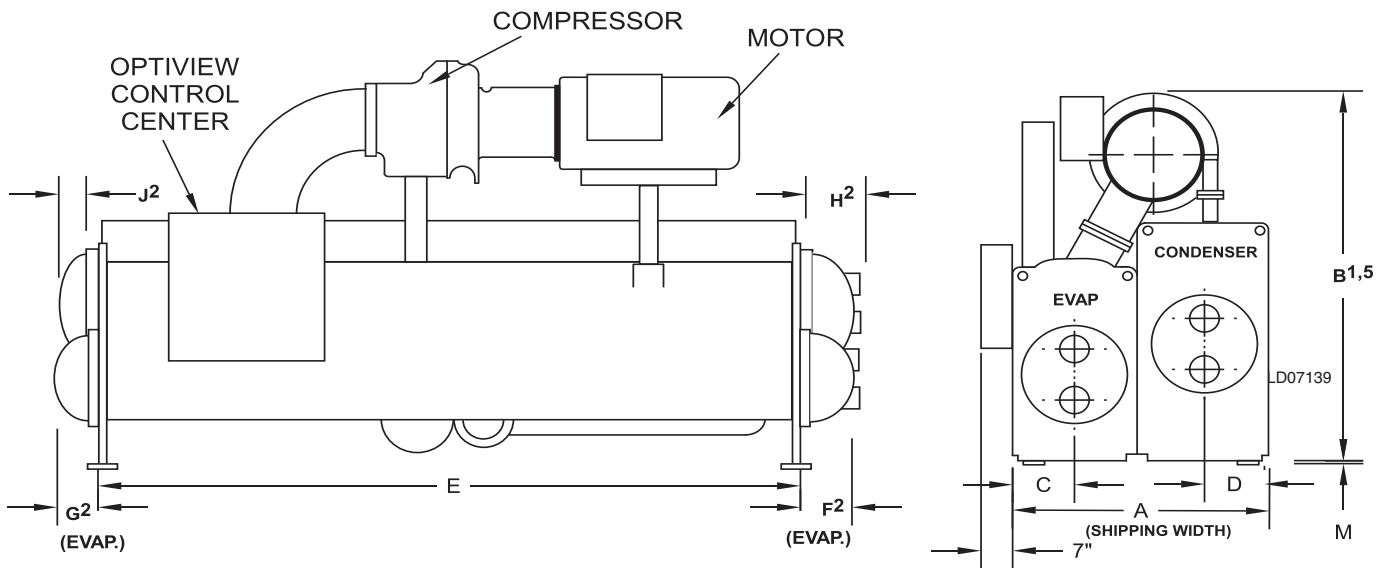

K1 COMPRESSOR, EVAPORATOR-CONDENSER SHELL CODES					
	K-K	M-M	N-N	P-P	Q-Q
A	2299	2616	2616	2781	2781
B	2921	3454	3454	3493	3493
C	641	724	724	749	749
D	508	584	584	641	641
E	4267	4267	4877	4267	4877

K2 COMPR., EVAPORATOR-CONDENSER SHELL CODES					
	M-M	M-U	N-N	P-P	Q-Q
A	2616	2896	2616	2781	2781
B	3454	3607	3454	3480	3480
C	724	724	724	749	749
D	584	724	584	641	641
E	4267	4267	4877	4267	4877

K4 COMPRESSOR, EVAPORATOR-CONDENSER SHELL CODES					
	R-R	S-S	S-V	X-T	X-X
A	2972	2972	3124	3302	3429
B	3632	3632	3759	3759	3759
C	813	813	813	902	902
D	699	699	749	749	813
E	4877	5486	5486	4877	4877

ADDITIONAL OPERATING HEIGHT CLEARANCE	
TYPE OF CHILLER MOUNTING	M
NEOPRENE PAD ISOLATORS	44
SPRING ISOLATORS 1" DEFLECTION	25
DIRECT MOUNT	19

K3 COMPR., EVAP.-COND. SHELL CODES			
	N-N	Q-Q	R-R
A	2616	2781	2972
B	3251	3505	3607
C	724	749	813
D	584	641	699
E	4877	4877	4877

K7 COMPR., EVAP.-COND SHELL CODES			
	W-W	Z-Y	Z-Z
A	3124	3835	3429
B	3708	4308	3912
C	813	902	902
D	749	1016	813
E	6706	5486	5486

**NOTES:**

1. All dimensions are approximate. Certified dimensions are available on request.
2. For all waterboxes (compact shown above), determine overall unit length by adding waterbox depth to tube sheet length.
3. Water nozzles can be located on either end of unit. Add 13 mm to nozzle length for flanged connections.
4. To determine overall height, add dimension "M" for the appropriate isolator type.
5. Use of motors with motor hoods may increase overall unit dimensions.
6. Tubesheets are provided with jacking point notches on P and larger shells.

# DIMENSIONS (MM) - NOZZLE ARRANGEMENTS

## EVAPORATORS – COMPACT WATERBOXES – A THRU L EVAPORATORS

Diagram of 1-Pass evaporator nozzle arrangement. It shows two views of the unit: the compressor end and the motor end. The compressor end has a nozzle labeled 'A' and the motor end has a nozzle labeled 'H'. Dimensions include AA (height), C (width), M (offset), and L (total width). The floor line is indicated between the two units.

1-PASS

NOZZLE ARRANGEMENTS		
NO. OF PASSES	EVAPORATOR	
	IN	OUT
1	A	H
	H	A

---

Diagram of 2-Pass evaporator nozzle arrangement. The compressor end has nozzles B and C, and the motor end has nozzles J and K. Dimensions include DD (height), BB (height), C (width), M (offset), and L (total width). The floor line is indicated between the two units.

2-PASS

NOZZLE ARRANGEMENTS		
NO. OF PASSES	EVAPORATOR	
	IN	OUT
2	C	B
	K	J

---

Diagram of 3-Pass evaporator nozzle arrangement. The compressor end has nozzles F and G, and the motor end has nozzles N and P. Dimensions include DD (height), BB (height), C (width), M (offset), and L (total width). The floor line is indicated between the two units.

3-PASS

NOZZLE ARRANGEMENTS		
NO. OF PASSES	EVAPORATOR	
	IN	OUT
3	G	N
	P	F

### COMPACT WATER BOXES - 150 PSI ROUND

EVAPORATOR SHELL CODE	NOZZLE PIPE SIZE(IN)			EVAPORATOR NOZZLE DIMENSIONS (MM)					
	NO. OF PASSES			C	1-PASS	2-PASS		3-PASS	
	1	2	3		AA <sup>5</sup>	BB <sup>5</sup>	DD <sup>5</sup>	BB <sup>5</sup>	DD <sup>5</sup>
A	8	6	4	394	559	356	762	356	762
C,D	10	8	6	445	610	381	838	381	838
E,F	14	10	8	483	660	406	914	406	914
G,H	14	10	8	610	699	394	1003	394	1003
J,K,L	16	12	10	641	762	432	1092	432	1092

**DIMENSIONS (MM) - NOZZLE ARRANGEMENTS - CONT.**

**EVAPORATORS – COMPACT WATERBOXES – M THRU Z EVAPORATORS**

1-PASS

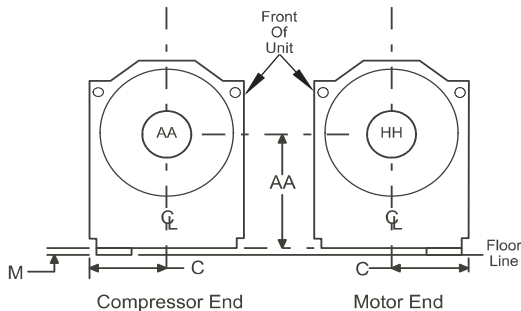

SHELL CODE	1 PASS	
	IN	OUT
M-Z	AA	HH
	HH	AA

2-PASS

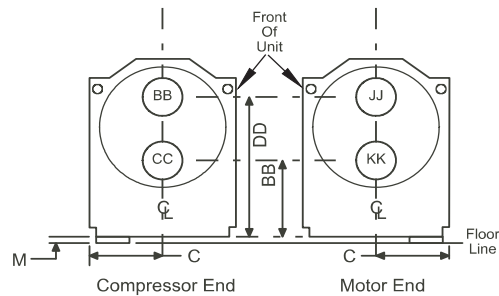

SHELL CODE	2 PASS	
	IN	OUT
M,N,P,Q	CC	BB
	KK	JJ

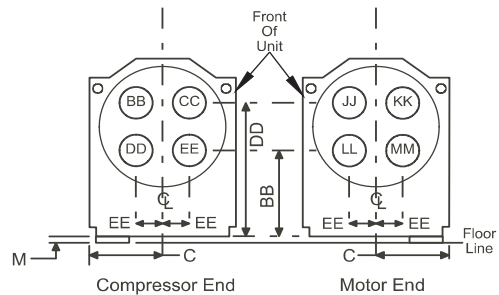

SHELL CODES	2 PASS	
	IN	OUT
R, S, W X & Z	DD	CC
	EE	BB
	LL	KK
	MM	JJ

3-PASS

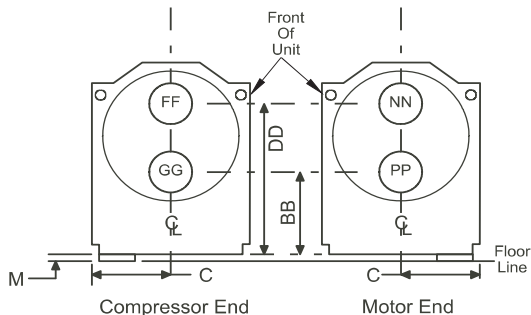

SHELL CODES	3 PASS	
	IN	OUT
M-Z	GG	NN
	PP	FF

**COMPACT WATER BOXES - 150 PSI**

EVAP SHELL CODE	NOZZLE PIPE SIZE(IN)			EVAPORATOR NOZZLE DIMENSIONS (MM)						
	NO. OF PASSES			C	1-PASS	2-PASS			3-PASS	
	1	2	3			AA <sup>5</sup>	BB <sup>5</sup>	DD <sup>5</sup>	EE	BB <sup>5</sup>
M,N	18	14	12	724	914	521	1308	-	521	1308
P,Q	18	14	12	749	953	559	1346	-	559	1346
QV, QT	20	16	12	749	953	597	1308	-	597	1308
R,S,W	20	18	14	813	1048	724	1384	267	635	1473
X,Z	20	18	14	902	1162	832	1492	279	683	1641

See Notes on page 53.





ONE PASS EVAPORATORS, CODES

DIM.	A	C,D	E,F	G,H	J,K,L	M,N	P,Q	QT,QV	R,S,W	X,Z
F	362	381	394	400	445	565	600	613	600	635

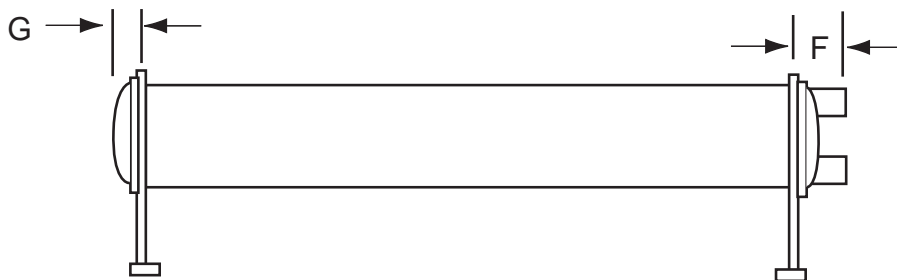

ONE PASS VERTICAL ACETATE EVAPORATORS, CODES

DIM.	A	C,D	V,F	G,H	J,K,L	M,Q	P,W	WQ,WR	T,S,N	X,Z
F	362	381	394	400	445	565	600	613	600	635
G	165	178	191	197	241	365	391	391	416	464



ONE PASS VERTICAL ACETATE EVAPORATORS, CODES

DIM.	S	C,D	F	G,N	H,J,K	M,L	A,Q	QQ,QR	E,V,W	X,Z
F	362	381	394	400	445	565	600	613	600	635

# DIMENSIONS (MM) - NOZZLE ARRANGEMENTS - CONT.

## CONDENSERS – COMPACT WATERBOXES

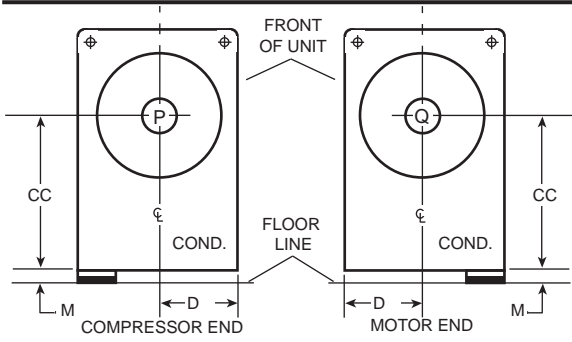

**1-PASS**

NOZZLE ARRANGEMENTS <sup>7</sup>		
NO. OF PASSES	CONDENSER	
	IN	OUT
1	P	Q
	Q	P

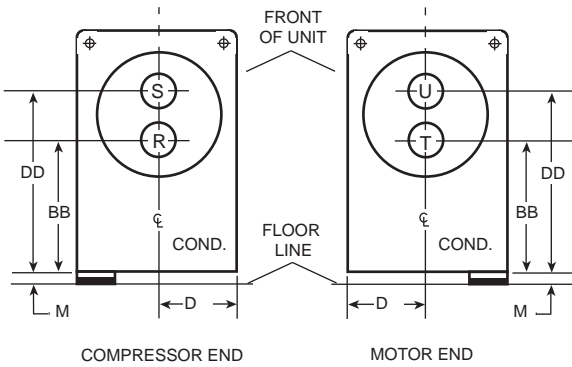

**2-PASS**

NOZZLE ARRANGEMENTS <sup>7</sup>		
NO. OF PASSES	CONDENSER	
	IN	OUT
2	R	S
	T	U

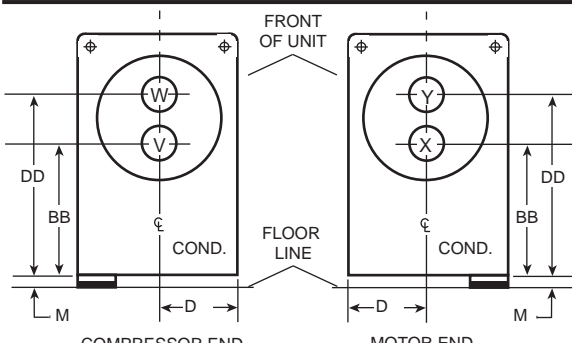

**3-PASS**

NOZZLE ARRANGEMENTS <sup>7</sup>		
NO. OF PASSES	CONDENSER	
	IN	OUT
3	V	Y
	X	W

### COMPACT WATER BOXES - 150 PSI ROUND

CONDENSER SHELL CODE	NOZZLE PIPE SIZE(IN)			D	1-PASS	2-PASS		3-PASS		
	NO. OF PASSES					CC <sup>5</sup>	BB <sup>5</sup>	DD <sup>5</sup>	BB <sup>5</sup>	DD <sup>5</sup>
	1	2	3							
A	10	6	6	381	711	546	876	546	876	
C,D	12	8	6	394	762	568	956	568	956	
E,F	14	10	8	445	813	603	1022	603	1022	
J,K,L	16	10	10	508	914	686	1143	686	1143	
M,N	20	14	10	584	1067	772	1362	772	1362	
P,Q	20	16	14	641	1118	787	1448	787	1448	
R,S	20	18	14	699	1181	851	1511	851	1511	
T,V,W	24	18	16	749	1207	838	1575	838	1575	
X,Z	24	20	16	813	1251	845	1657	845	1657	

**NOTES:**

- Standard water nozzles are furnished as welding stub-outs with ANSI/AWWA C-606 grooves, allowing the option of welding, flanges, or use of ANSI/AWWA C-606 couplings. Factory-installed, class 150 (ANSI B16.5, round slip-on, forged carbon steel with 1.6 mm raised face), water flanges nozzles are optional (add 13 mm to nozzle length). Companion flanges, nuts, bolts, and gaskets are not furnished.
- One, two and three pass nozzle arrangements are available in pairs shown and for all shell codes. Any pair of evaporator nozzles may be used in combination with any pair of condenser nozzles.
- Evaporator and condenser water must enter the waterbox through the bottom connection to achieve rated performance.
- Connected piping should allow for removal of compact waterboxes for tube access and cleaning.
- Add dimension "M" as shown on the unit dimensions page for the appropriate isolator type.
- Standard 150 psi (1034 kPa) design pressure waterboxes shown.
- Shell codes R,S,T,V,W,X, & Z use double letter nozzle codes in the same orientation as the single letter e.g. P = PP.



ONE PASS



TWO PASS



THREE PASS

SINGLE BUNDLE CONDENSERS, CODES

DIM.	A	C,D	E,F	J,K,L	M,N	P,Q	R,S	T,V,W	X,Z
H	352	352	381	394	391	445	527	572	600
J	149	165	178	191	197	241	365	391	416

DOUBLE BUNDLE HEAT RECOVERY CONDENSERS, CODES

DIM.	B		I		O		U		Y	
	TOWER	HEATING	TOWER	HEATING	TOWER	HEATING	TOWER	HEATING	TOWER	HEATING
H	470	432	495	425	546	457	565	508	730	572
J	267	229	292	222	343	254	362	305	527	368

# DIMENSIONS (MM) - NOZZLE ARRANGEMENTS - CONT.

## HEAT RECOVERY UNITS

1-PASS

### 1 PASS NOZZLE ARRANGEMENTS

	IN	OUT
<b>HEAT RECOVERY</b>	EE	FF
<b>COOLING TOWER</b>	P	Q

2-PASS

### 2 PASS NOZZLE ARRANGEMENTS

	IN	OUT
<b>HEAT RECOVERY</b>	AA	BB
<b>COOLING TOWER</b>	R	S

3-PASS

### 3 PASS NOZZLE ARRANGEMENTS

	IN	OUT
<b>HEAT RECOVERY</b>	GG	HH
<b>COOLING TOWER</b>	V	Y

### COMPACT WATER BOXES - 150 PSI (RECTANGULAR)

CONDENSER SHELL CODE	NOZZLE PIPE SIZE (IN)			1, 2 OR 3 PASS			2 PASS
	NUMBER OF PASSES						
	1	2	3	D	K	L	I
<b>B</b>	10	8	6	530	540	1080	230
<b>I</b>	14	10	8	594	565	1121	257
<b>O</b>	16	12	10	695	619	1248	300
<b>U</b>	18	14	10	724	894	1595	314
<b>Y</b>	24	20	16	1016	1014	1927	454

**DIMENSIONS (MM) - NOZZLE ARRANGEMENTS - CONT.**

**EVAPORATORS – MARINE WATERBOXES**

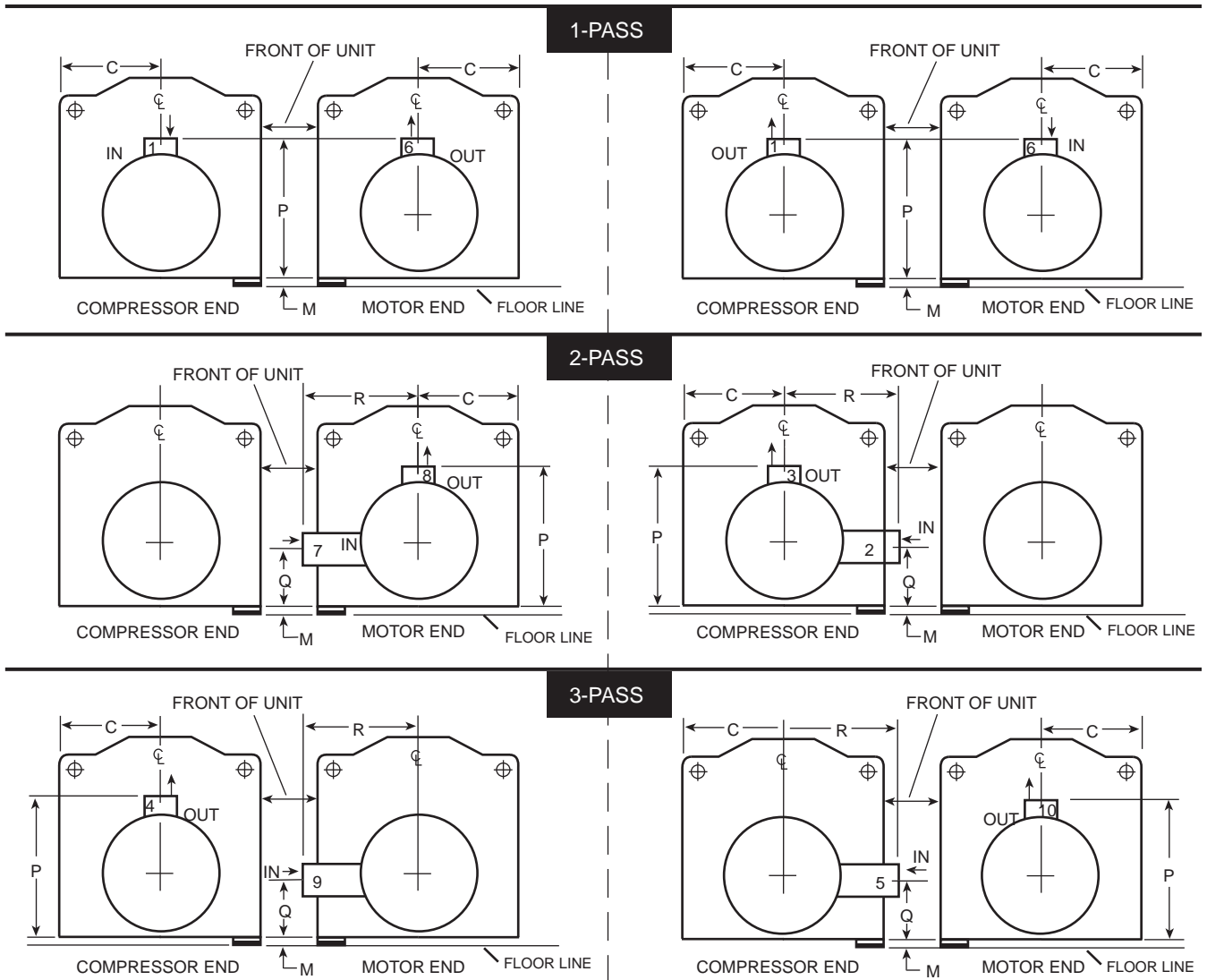

CONDENSER SHELL CODE				MARINE WATER BOXES - 150 PSI ROUND								
EVAP SHELL CODE	NOZZLE PIPE SIZE(IN)			C	1-PASS	2-PASS			3-PASS			
	NO. OF PASSES					P <sup>s</sup>	P <sup>s</sup>	Q <sup>s</sup>	R	P <sup>s</sup>	Q <sup>s</sup>	R
	1	2	3									
A	1	8	4	274	9573	9573	307	210	9573	307	210	
C,D	95	1	8	44-	9974	9974	3-4	405	9974	3-4	405	
E,F	94	95	1	47-	937-	937-	307	-48	937-	307	-48	
G,H	94	95	1	895	9450	9450	380	-70	9450	380	-70	
J,K,L	98	93	95	849	9-24	9-24	380	802	9-24	380	802	
M,N	91	94	93	034	9045	9045	2-8	802	9045	2-8	025	
P,Q	91	94	93	047	9123	9123	219	00-	9123	219	00-	
QT,QV	35	98	93	047	9123	9123	497	00-	9123	497	00-	
R,S	35	91	94	192	9701	9701	6-0	791	9701	6-0	791	
W	35	91	94	192	9701	9701	6-0	791	9701	6-0	791	
X,Z	35	91	94	753	3987	3987	-45	722	3987	-45	722	

See Notes on pf 30.



**DIMENSIONS (MM) - NOZZLE ARRANGEMENTS - CONT.**

EVAPORATOR	
1-PASS	
IN	OUT
1	6
6	1

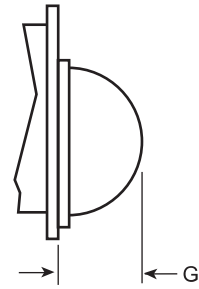
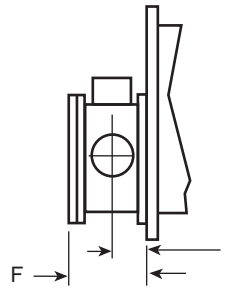

(2-PASS RETURN HEAT)

EVAPORATOR	
2-PASS	
IN	OUT
2	3
7	8

EVAPORATOR	
3-PASS	
IN	OUT
5	10
9	4

EVAP SHELL CODE	1-PASS		2-PASS			3-PASS	
	F	I	F	G	I	F	I
A	483	222	432	165	197	432	197
C,D	578	270	524	178	241	524	241
E,F	654	308	559	191	260	559	260
G,H	660	302	572	286	260	572	260
J,K,L	686	314	597	241	268	597	267
M,N	762	343	660	308	292	660	292
P,Q	762	343	660	343	292	660	292
QT,QV	813	368	711	343	318	711	318
R,S,W	813	371	762	368	346	762	346
X,Z	838	371	762	394	346	762	346

**NOTES:**

1. All dimensions are approximate. Certified dimensions are available upon request.
2. Standard water nozzles are Schedule 40 pipe size, furnished as welding stub-outs with ANSI/AWWA C-606 grooves, allowing the option of welding, flanges, or use of ANSI/AWWA C-606 couplings. Factory-installed, class 150 (ANSI B16.5, round slip-on, forged carbon steel with 1.6 mm raised face), water flanged nozzles are optional (add 13 mm to nozzle length). Companion flanges, nuts, bolts, and gaskets are not furnished.
3. One-, two-, and three-pass nozzle arrangements are available only in pairs shown and for all shell codes. Any pair of evaporator nozzles may be used in combination with any pair of condenser nozzles. Compact waterboxes on one heat exchanger may be used with Marine Waterboxes on the other heat exchanger.
4. Water must enter the waterbox through the bottom connection to achieve rated performance.
5. Add dimension "M" as shown on the unit dimensions page for the appropriate isolator type.

**DIMENSIONS (MM) - NOZZLE ARRANGEMENTS - CONT.**

**CONDENSERS – MARINE WATERBOXES**

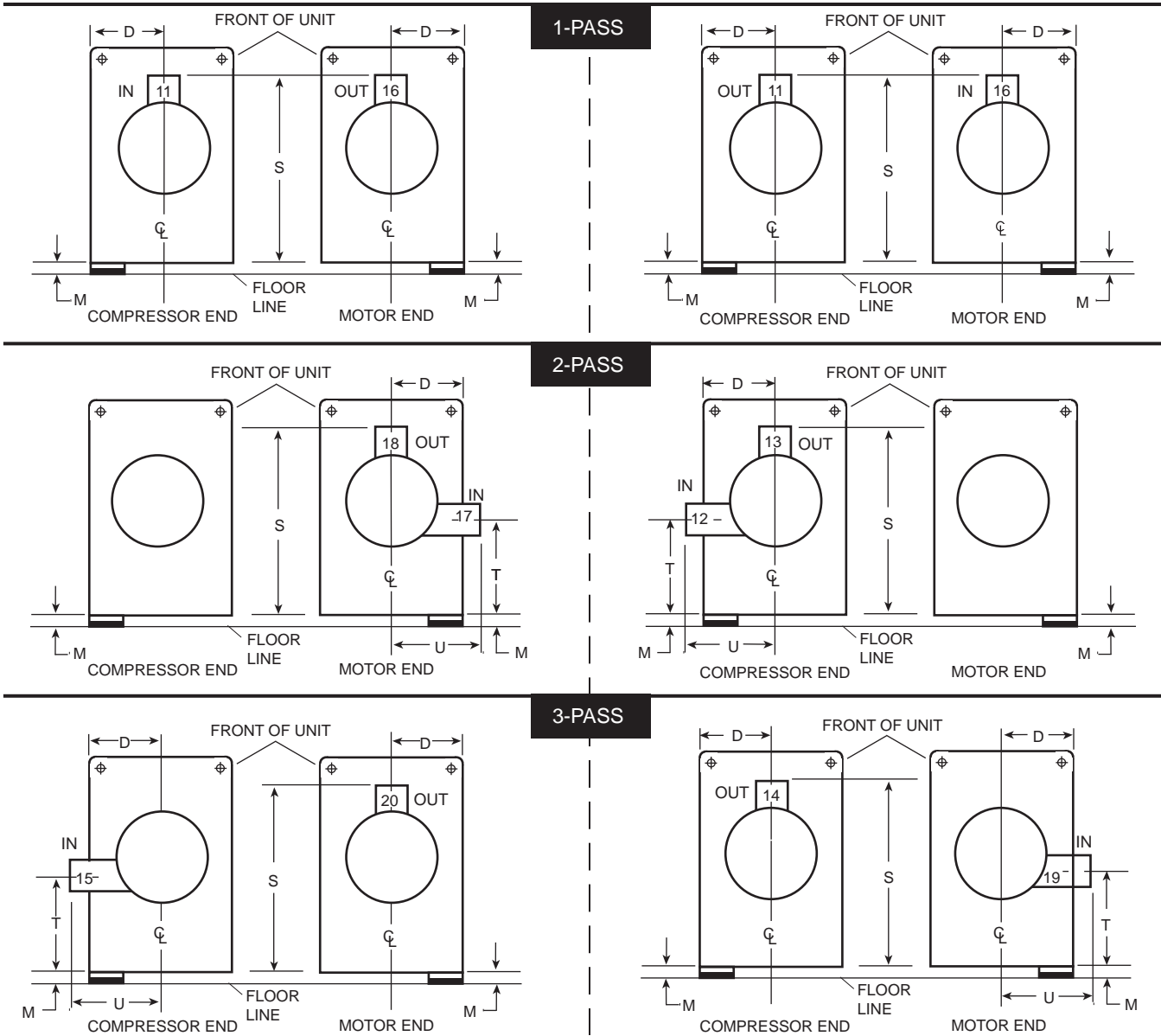

**MARINE WATER BOXES - 150 PSI ROUND**

CONDENSER SHELL CODE	NOZZLE PIPE SIZE(IN)			D	1-PASS	2-PASS			3-PASS			
	NO. OF PASSES					S <sup>5</sup>	S <sup>5</sup>	T <sup>5</sup>	U	S <sup>5</sup>	T <sup>5</sup>	U
	1	2	3									
A	10	6	6	381	1194	1194	508	391	1194	508	391	
C,D	12	8	6	394	1295	1295	508	470	1295	508	470	
E,F	14	10	8	445	1397	1397	559	533	1397	559	533	
J,K,L	16	10	10	508	1549	1549	533	546	1549	533	546	
M,N	20	14	10	584	1775	1775	711	648	1775	711	648	
P,Q	20	16	14	641	1889	1889	724	749	1889	724	749	
R,S	20	18	14	699	2007	2007	775	826	2007	775	826	
T,V,W	24	18	16	749	2089	2089	762	864	2089	762	864	
X,Z	24	20	16	813	2184	2184	806	902	2184	806	902	

**DIMENSIONS (MM) - NOZZLE ARRANGEMENTS - CONT.**

CONDENSER	
1-PASS	
IN	OUT
11	16
16	11

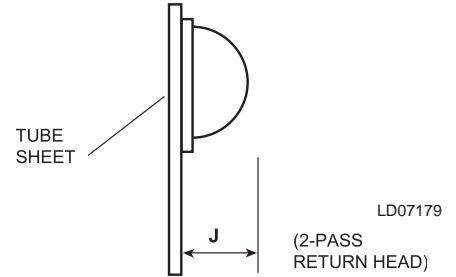
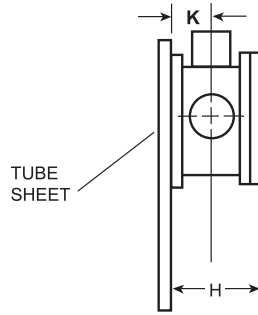

CONDENSER	
2-PASS	
IN	OUT
12	13
17	18

CONDENSER	
3-PASS	
IN	OUT
15	20
20	15

COND SHELL CODE	1-PASS		2-PASS			3-PASS	
	H	K	H	J	K	H	K
A	533	251	425	152	197	425	197
B <sup>6</sup>	572	267	508	267	235	508	235
C,D	610	283	495	162	229	495	229
E,F	622	292	565	178	251	565	251
I <sup>6</sup>	686	324	572	292	267	572	267
J,K,L	686	318	584	191	260	584	260
M,N	813	378	660	203	305	660	305
O <sup>6</sup>	768	362	654	343	305	654	305
P,Q	813	368	711	241	318	711	318
R,S	813	368	762	305	343	762	343
T,V,W	914	419	762	279	343	762	343
U <sup>6</sup>	813	381	711	362	330	711	330
X,Z	914	422	813	279	371	813	356
Y <sup>6</sup>	1035	489	921	527	432	921	432

**NOTES:**

1. All dimensions are approximate. Certified dimensions are available upon request.
2. Standard water nozzles are Schedule 40 pipe size, furnished as welding stub-outs with ANSI/AWWA C-606 grooves, allowing the option of welding, flanges, or use of ANSI/AWWA C-606 couplings. Factory-installed, class 150 (ANSI B16.5, round slip-on, forged carbon steel with 1.6 mm raised face), water flanged nozzles are optional (add 13 mm to nozzle length). Companion flanges, nuts, bolts, and gaskets are not furnished.
3. One-, two-, and three-pass nozzle arrangements are available only in pairs shown and for all shell codes. Any pair of evaporator nozzles may be used in combination with any pair of condenser nozzles. Compact waterboxes on one heat exchanger may be used with Marine Waterboxes on the other heat exchanger.
4. Condenser water must enter the waterbox through the bottom connection for proper operation of the sub-cooler to achieve rated performance.
5. Add dimension "M" as shown on the unit dimension page for the appropriate isolator type.

**DIMENSIONS (MM) - NOZZLE ARRANGEMENTS - CONT.**

**CONDENSERS – MARINE WATERBOXES**  
**Heat Recovery Units - Main (Tower) Circuit Only**

**1-PASS**

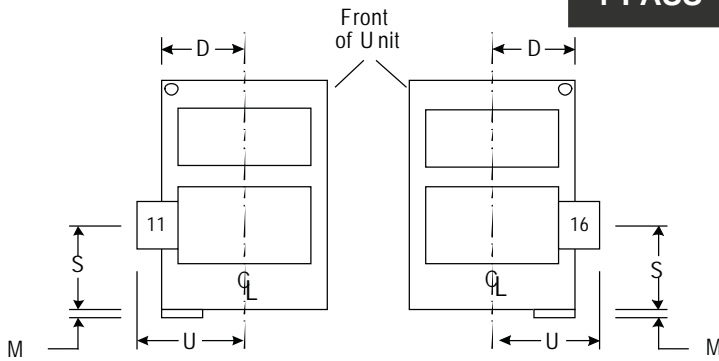

CONDENSER NOZZLE OPTIONS	COOLING WATER	
	IN	OUT
1 Pass	11	16
	16	11
2 Pass	12	13
	17	18
3 Pass	15	20
	19	14

**2-PASS**

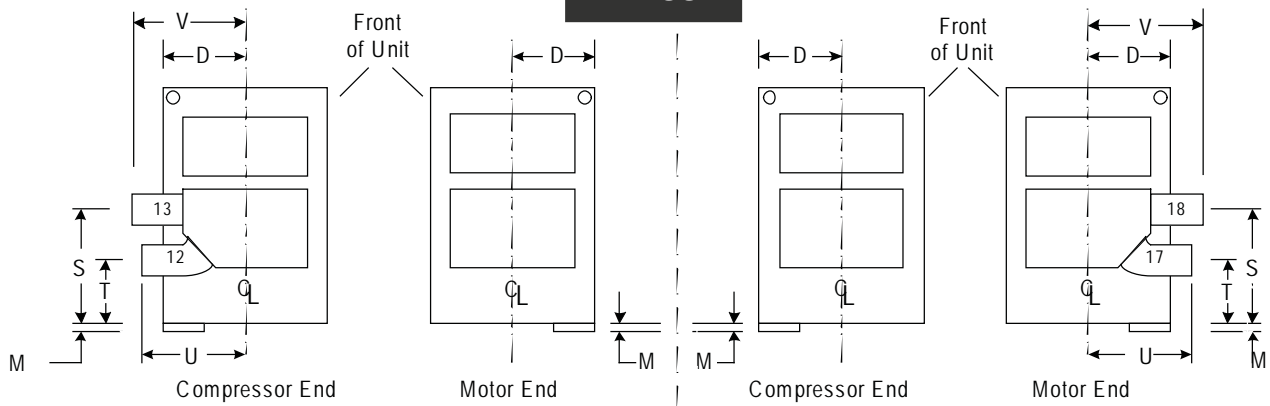

**3-PASS**

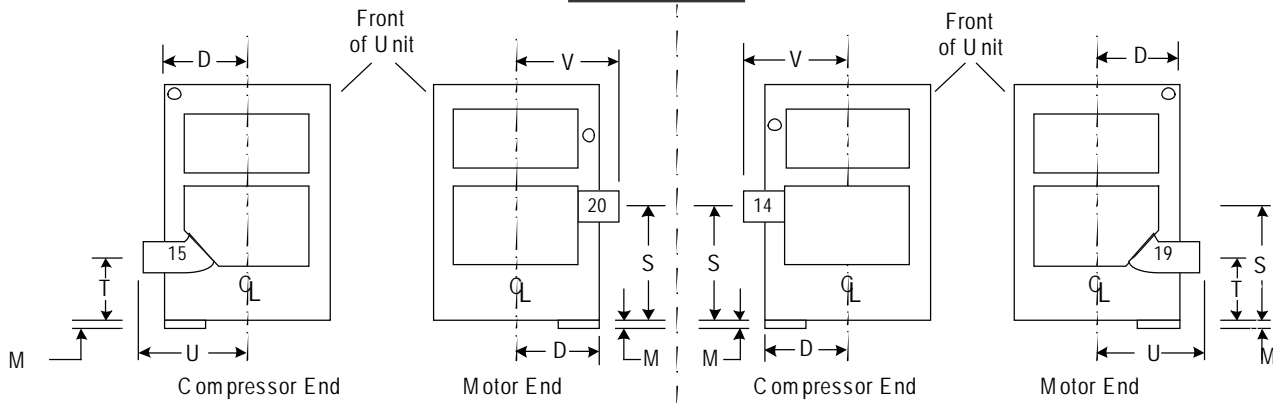

MARINE WATER BOXES - 150 PSI (RECTANGULAR)

CONDENSER SHELL CODE	NOZZLE PIPE SIZE (IN)			1 PASS				2 PASS				3 PASS			
	1	2	3	D	S	U	S	T	U	V	S	T	U	V	
B	10	8	6	530	540	281	692	354	230	291	274	445	281	281	
I	14	10	8	594	565	848	274	330	240	829	249	462	841	841	
O	16	17	10	695	619	925	291	340	820	1079	877	498	967	967	
U	18	14	10	274	894	1056	1081	589	967	1105	1177	260	937	991	
Y	74	70	16	1016	1014	1411	1728	562	1340	1516	1379	299	1727	1397	

**WEIGHTS****TABLE 6 – APPROXIMATE UNIT WEIGHT INCLUDING MOTOR<sup>2</sup>**

SHELLS	COMPRESSOR	SHIPPING WEIGHT (KGS.)	OPERATING WEIGHT (KGS.)	EST. REFRIGERANT CHARGE (KGS.) <sup>1</sup>
A-A	Q3	5,942	6,804	376
C-B	Q4	8,175	10,126	692
C-C	Q3, Q4	6,768	8,138	554
C-C	Q5	6,954	8,324	554
D-D	Q3, Q4	7,809	9,571	738
D-D	Q5	7,995	9,757	738
E-E	Q3, Q4	8,142	10,052	776
E-E	Q5,Q6,Q7,P7	8,328	10,238	776
E-I	Q7	10,690	13,328	819
F-F	Q5,Q6,Q7,P7	8,491	10,832	987
G-E	P8	9,208	10,977	903
H-F	P8,P9	10,478	12,701	1,184
J-J	P8,P9	10,886	13,200	1,157
L-L	P8,P9	12,429	15,377	1,436
K-K	H9	12,941	16,329	1,327
K-K	K1	14,107	16,420	1,473
K-O	H9	15,641	20,310	1,479
M-M	H9	15,513	19,777	1,662
M-M	K1,K2	17,373	21,364	1,662
M-U	K2	20,493	26,316	1,606
N-N	K1,K2	18,549	23,043	1,916
N-N	K3	21,773	24,540	1,916
P-P	K1,K2	18,824	23,542	1,749
Q-Q	K1,K2	20,548	25,764	1,930
Q-Q	K3	20,865	27,307	1,930
R-R	K3	23,950	31,888	2,087
R-R	K4	24,041	32,024	2,087
S-S	K4	26,762	34,609	2,184
S-V	K4	27,261	36,877	2,480
X-T	K4	26,853	36,288	2,421
X-X	K4	29,937	39,463	2,665
W-W	K7	36,061	47,174	3,630
Z-Y	K7	43,196	55,799	3,255
Z-Z	K7	36,515	47,628	3,168

<sup>1</sup> Refrigerant charge quantity and weights will vary based on tube count.<sup>2</sup> Refer to product drawings for detailed weight information.**TABLE 6A - APPROXIMATE UNIT WEIGHT INCLUDING MOTOR****UNIT WITH HYBRID FALLING FILM EVAPORATOR**

SHELLS	COMPRESSOR	SHIPPING WEIGHT (KGS.)	OPERATING WEIGHT (KGS.)	EST. REFRIGERANT CHARGE (KGS.) <sup>1</sup>
A-A	Q3	5,829	6,540	315
C-C	Q3, Q4	6,609	7,642	397
C-C	Q5	6,804	7,837	397
D-D	Q4	7,711	9,095	535
D-D	Q5	7,897	9,281	535
E-E	Q5,Q6,Q7,P7	8,482	9,843	508
F-F	Q5,Q6,Q7,P7	8,718	10,497	642
G-E	P8, P9	9,362	10,903	599
H-F	P8, P9	10,678	12,738	805
K-K	H9	13,086	15,458	826

<sup>1</sup> Refrigerant charge quantity and weights will vary based on tube count and configuration. Use for reference only.



**TABLE 7 – EVAPORATOR MARINE WATERBOX WEIGHTS (KGS.)**  
(TO BE ADDED TO STANDARD UNIT WEIGHTS SHOWN ON TABLE 6)

EVAP. CODE	SHIPPING WEIGHT			OPERATING WEIGHT		
	INCREASE - KGS.			INCREASE - KGS.		
	1-PASS	2-PASS	3-PASS	1-PASS	2-PASS	3-PASS
A	419	337	444	666	584	690
C,D	613	505	671	1,009	901	1,067
E,F	852	572	943	1,532	1,252	1,624
G,H	550	588	587	1,204	1,242	1,241
J,K,L	794	836	842	1,753	1,794	1,800
M,N	1,946	924	1,878	3,418	1,481	2,858
P,Q	2,115	1,021	2,107	3,514	1,581	3,353
R,S,W	2,179	1,225	2,228	3,866	2,048	3,714
X,Z	3,215	1,660	3,286	5,240	2,498	5,100

**TABLE 8 – CONDENSER MARINE WATERBOX WEIGHTS (KGS.)**  
(TO BE ADDED TO STANDARD UNIT WEIGHTS SHOWN ON TABLE 6)

COND. CODE	SHIPPING WEIGHT			OPERATING WEIGHT		
	INCREASE - KGS.			INCREASE - KGS.		
	1-PASS	2-PASS	3-PASS	1-PASS	2-PASS	3-PASS
A	346	257	367	578	489	600
B	712	396	761	958	496	939
C,D	429	353	474	767	691	813
E,F	329	368	359	606	781	772
I	937	485	922	1,369	642	1,242
J,K,L	467	529	522	1,047	1,110	1,103
M,N	1,119	603	1,054	2,206	1,110	2,078
O	1,354	655	1,355	2,012	985	1,805
P,Q	1,678	843	1,702	2,976	1,421	2,717
R,S	1,726	883	1,796	3,020	1,449	2,881
V,T,W	2,357	1,163	2,361	4,155	1,820	3,728
U	1,652	859	1,637	2,427	1,159	2,164
X,Z	2,649	1,339	2,440	4,491	2,109	3,674
Y	4,125	2,160	4,109	6,045	2,959	5,465



[www.johnsoncontrols.com](http://www.johnsoncontrols.com)