



ISOFLOW ABSORPTION CHILLERS WITH BUFFALO PUMPS

INSTALLATION INSTRUCTIONS

Supersedes: 155.16-N3 (1094)

Form 155.16-N3 (899)

MODELS

STEAM

YIA-ST-1A1 THRU YIA-ST-14F3

HOT WATER

YIA-HW-1A1 THRU YIA-HW-14F3

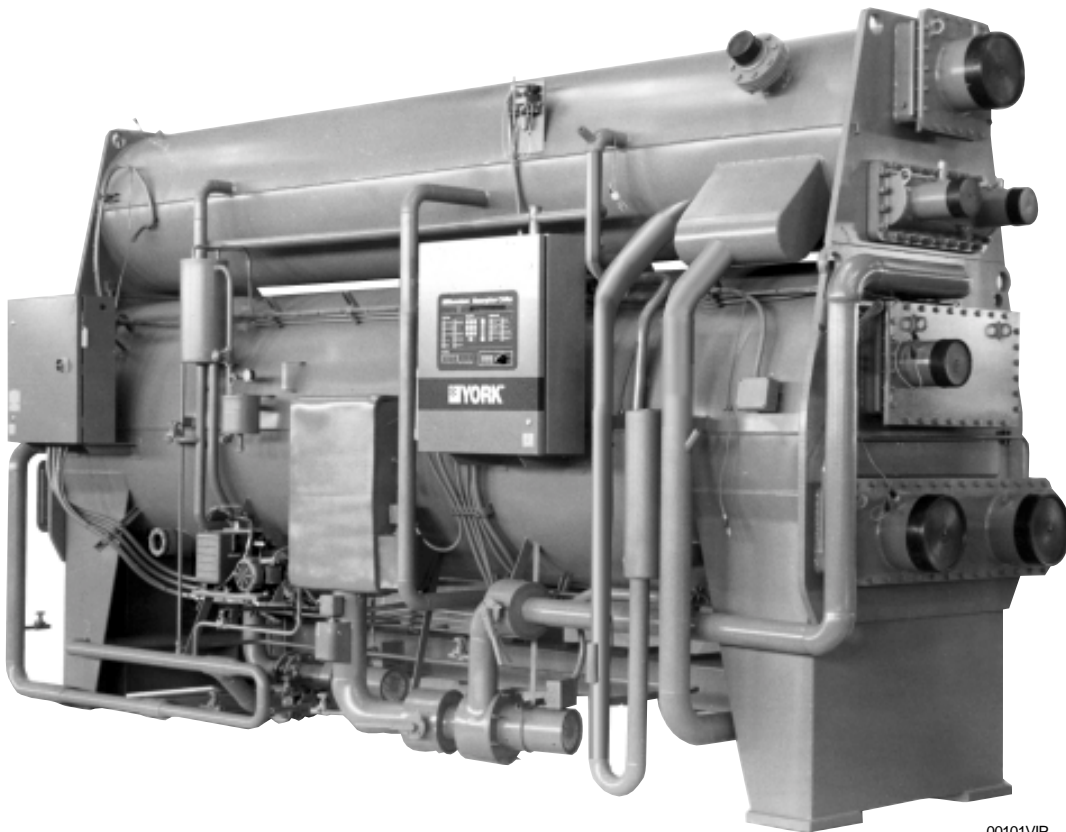

00101VIP

IMPORTANT!

READ BEFORE PROCEEDING!

GENERAL SAFETY GUIDELINES

This equipment is a relatively complicated apparatus. During installation, operation, maintenance or service, individuals may be exposed to certain components or conditions including, but not limited to: refrigerants, oils, materials under pressure, rotating components, and both high and low voltage. Each of these items has the potential, if misused or handled improperly, to cause bodily injury or death. It is the obligation and responsibility of operating/service personnel to identify and recognize these inherent hazards, protect themselves, and proceed safely in completing their tasks. Failure to comply with any of these requirements could result in serious damage to the equipment and the property in which it is situated, as well as severe personal injury or death to themselves and people at the site.

This document is intended for use by owner-authorized operating/service personnel. It is expected that this individual possesses independent training that will enable them to perform their assigned tasks properly and safely. It is essential that, prior to performing any task on this equipment, this individual shall have read and understood this document and any referenced materials. This individual shall also be familiar with and comply with all applicable governmental standards and regulations pertaining to the task in question.

SAFETY SYMBOLS

The following symbols are used in this document to alert the reader to areas of potential hazard:



DANGER indicates an imminently hazardous situation which, if not avoided, will result in death or serious injury.



WARNING indicates a potentially hazardous situation which, if not avoided, could result in death or serious injury.



CAUTION identifies a hazard which could lead to damage to the machine, damage to other equipment and/or environmental pollution. Usually an instruction will be given, together with a brief explanation.

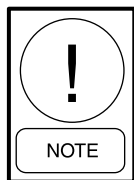

NOTE is used to highlight additional information which may be helpful to you.

CHANGEABILITY OF THIS DOCUMENT

In complying with YORK's policy for continuous product improvement, the information contained in this document is subject to change without notice. While YORK makes no commitment to update or provide current information automatically to the manual owner, that information, if applicable, can be obtained by contacting the nearest YORK Applied Systems Service office.

It is the responsibility of operating/service personnel to verify the applicability of these documents to the equipment in question. If there is any question in the mind of operating/service personnel as to the applicability of these documents, then prior to working on the equipment, they should verify with the owner whether the equipment has been modified and if current literature is available.

TABLE OF CONTENTS

| | |
|---|----|
| NOMENCLATURE | 6 |
| INTRODUCTION | 7 |
| ADVANCED PREPARATION | 7 |
| INITIAL INSPECTION OF UNIT | 7 |
| FOUNDATION | 8 |
| LEVELING THE UNIT | 8 |
| SHIPMENT | 8 |
| SOLUTION AND REFRIGERANT SHIPMENT | 8 |
| UNIT RIGGING | 10 |
| One Piece Unit Shipment | 10 |
| Two Piece Unit Shipment | 10 |
| UNIT ASSEMBLY CONNECTIONS FOR TWO PIECE SHIPMENTS | 12 |
| INSTALLING THE ABSOLUTE PRESSURE GAUGE | 19 |
| COMPLETING THE PURGE PUMP CONNECTIONS | 19 |
| UNIT WATER PIPING | 19 |
| Strainers | 20 |
| Absorber and Condenser Water Piping | 20 |
| RUPTURE DISK AND RELIEF PIPING | 21 |
| INLET STEAM PIPING | 21 |
| Inlet Steam Piping Components | 22 |
| STEAM CONDENSATE RETURN SYSTEM | 24 |
| Condensate Return System Components | 24 |
| HOT WATER PIPING | 30 |
| Inlet and Outlet Hot Water Piping | 31 |
| ELECTRICAL CONNECTIONS | 33 |
| INSULATION | 41 |
| Insulation Tips | 41 |
| INSTALLATION CHECK LIST | 41 |

LIST OF ILLUSTRATIONS

| <u>Fig.</u> | | <u>Page</u> |
|-------------|--|-------------|
| 1 | Isolation Pads | 8 |
| 2 | Model YIA IsoFlow™ Absorption Chiller Major Components | 9 |
| 3 | Unit Rigging | 10 |
| 4 | Unit assembly for models 1A1 thru 2A4 | 13 |
| 5 | Unit assembly for models 2B1 thru 4B4 | 14 |
| 6 | Unit assembly for models 4C1 thru 6C4 | 15 |
| 7 | Unit assembly for models 7D1 thru 8D3 | 16 |
| 8 | Unit assembly for models 8E1 thru 10E3 | 17 |
| 9 | Unit assembly for models 12F1 thru 14F3 | 18 |
| 10 | Purge Pump | 19 |
| 11 | Installation of Flow Switches | 20 |
| 12 | Typical cooling tower piping | 21 |
| 13 | Unit inlet steam piping | 23 |
| 14 | System 1 - Atmospheric condensate return system | 28 |
| 15 | System 2 - Vacuum condensate return system | 29 |
| 16 | System 3 - Vacuum condensate return system when inlet steam and outlet condensate are under vacuum | 30 |
| 17 | Diverting service for Honeywell valve | 31 |
| 18 | Diverting service for Fisher valve | 31 |
| 19 | Typical hot water piping system | 32 |
| 20 | System water pump and flow switch interface details | 36 |
| 21 | Steam and hot water unit field wiring | 37 |
| 22 | IsoFlow™ micro panel control center component locations | 38 |
| 23 | IsoFlow™ power panel component locations | 39 |
| 24 | IsoFlow™ power panel component locations | 40 |

LIST OF TABLES

| <u>Table</u> | | |
|--------------|--|----|
| 1 | Unit weights and dimensions | 11 |
| 2 | Shell and tube volumes | 27 |
| 3 | Electrical ratings | 34 |
| 4 | Approximate insulation for hot and cold surfaces | 42 |
| 5 | Unit Charge Quantities | 43 |

OTHER RELATED PUBLICATIONS

| <u>Form number</u> | <u>Description</u> |
|--------------------|---|
| 155.16-PA1 | Field control modifications diagram for millennium control center |
| 155.16-PA1.1 | Dimensions and physical data for Steam Heat source units |
| 155.16-PA1.2 | Dimensions and physical data for Hot Water heat source units |
| 155.16-PA2 | Field connections for micro panel control center |
| 155.16-W1 | Wiring diagram for units with Franklin pumps |
| 155.16-W3 | Wiring diagram for CE coded units with Franklin pumps |
| 155.16-W4 | Wiring diagram for all units with Buffalo pumps |

OTHER IMPORTANT MATERIALS

Installation Check list and request for authorized start-up engineer

(back cover)

NOMENCLATURE

The model number denotes the following characteristics of the unit:

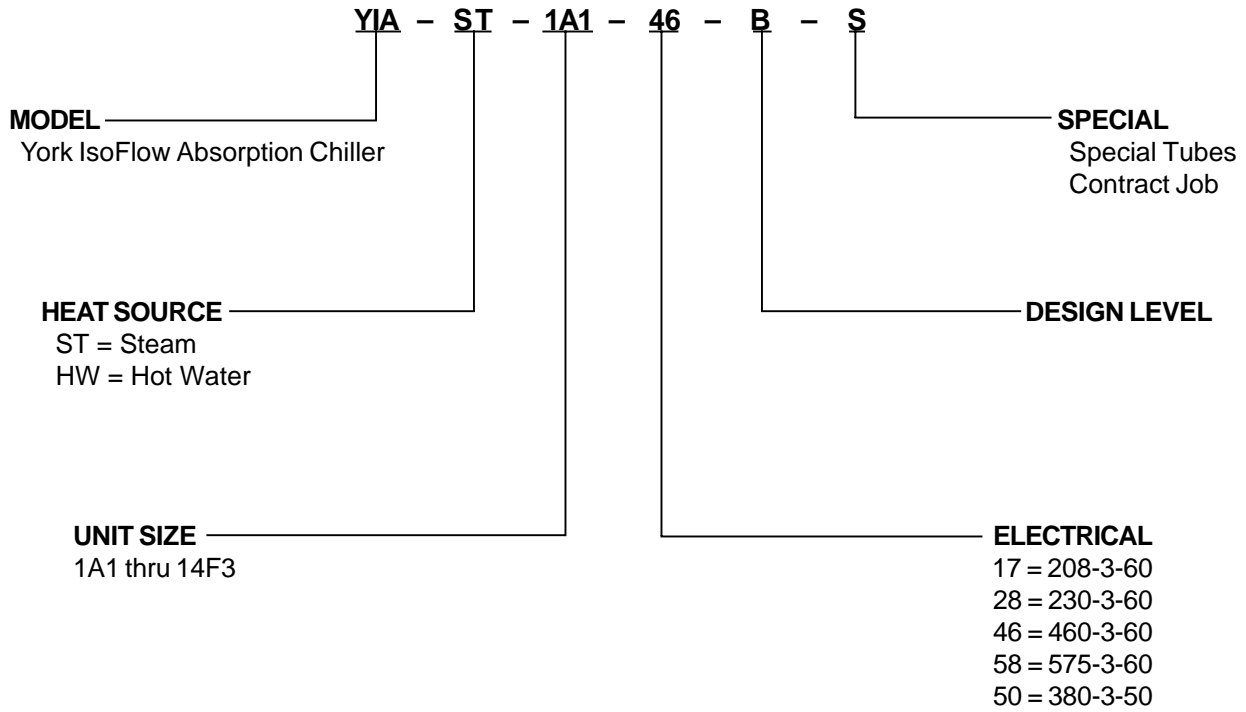

INTRODUCTION

This instruction describes the installation of an IsoFlow Absorption Chiller with Buffalo pumps. The IsoFlow unit is a complete self-contained, forced circulation refrigeration system using steam or hot water as the activation medium. De-ionized water is used as the refrigerant and 55% concentrated lithium bromide solution is used as an absorbent. The system consists of a generator-condenser shell mounted on top of an absorber-evaporator shell assembly. The system also utilizes a solution pump, refrigerant pump, purge pump and interconnecting piping. See **Fig. 1** for major component and piping locations.

For more detailed information about design, specifications or operations on the particular unit you are installing, please contact your local YORK office.

When using this manual, the installer should pay particular attention to the words: DANGER, WARNING, CAUTION and NOTE. These words are followed by symbols to alert the reader of areas of potential hazard. For further explanation see the safety section at the front of this document.

The contractor is advised to become thoroughly familiar with the operation, installation, maintenance and service requirements of the YORK IsoFlow™ chiller. Careful study of the factory submittal drawings and this manual is recommended. YORK representatives are available to answer any questions and to coordinate delivery of the unit and its accessories.

YORK should be advised by the contractor of the scheduled start-up time so that qualified personnel can be made available on that date. YORK requires a minimum of four weeks advance notice to schedule a start-up and to have the lithium bromide solution delivered to the jobsite.

ADVANCED PREPARATION

It is recommended to do a first-hand job site inspection to ensure a smooth installation process for your YORK IsoFlow™ absorption chiller. Check all factory submittals and drawings to verify unit clearances, overall dimensions and weight. Electrical requirements, steam or hot water pressure and temperature, foundation dimensions should also be verified before the chiller arrives.

In selecting a site, consider structural support, access for service and tube pull area on either end of the unit. (Tube pull area is approximately equal to the length of the main shell). Follow standard engineering practice in designing the piping system and other services. **Adequate support must be provided for system piping so that no weight is placed on the unit water boxes and connecting nozzles.**

A minimum of 42 inches of service space is recommended along each side of the unit. Tube pull space equivalent to one unit length must be provided on one end of the unit. On the other end, opposite the tube pull end, a space of 60 inches is recommended for service clearance. There should be at least 20 inches of space above the unit.

YORK IsoFlow™ chillers are quiet and free of vibration. Therefore, spring-type vibration eliminating mountings are not required. Mounting pads should be used, however, when the unit is installed in an area where even mild noise would be objectionable, such as near a conference room, sleeping area or on a roof. If this is the case, it is recommended to seek the advice of an acoustical consultant.

YORK IsoFlow™ chillers are not suitable for outdoor installations. They must not be stored in temperatures below 35°F. The machine room must be enclosed, well lighted and properly ventilated to keep its temperature no higher than 104°F and no lower than 35°F. Relative humidity in the machine room must never reach the saturation point. Condensation of moisture may cause corrosion and damage to electrical components.

INITIAL INSPECTION OF UNIT

The shipment should be checked on arrival to see that all major pieces, boxes and crates are received. The unit should be checked on the trailer or rail car when received, before unloading, for any visible signs of damage. Any damage or signs of possible damage should be reported to the transportation company immediately for their inspection. **YORK will not be responsible for any damage in shipment or at the job site or loss of parts.**

INITIAL INSPECTION OF UNIT (CON'T)

When received at the jobsite, all containers should be opened and contents checked against the packing list or shipping orders. Any material shortage must be reported to YORK immediately! (Refer to Shipping Damage Claims Form 50.15-NM).

FOUNDATION

The foundation must be able to support the full weight of the unit when fully charged with refrigerant and solution. The foundation must be made of concrete and level within 1/4 inch at the four mounting legs of the unit. For foundation and unit dimensions see YORK forms 155.16-PA1.1 and 155.16-PA1.2.

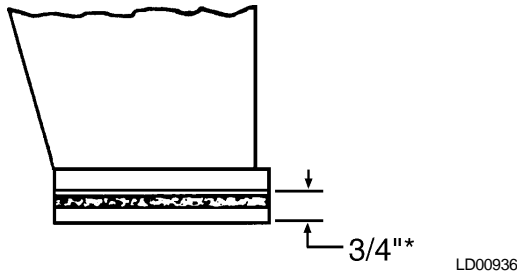

* Compressed thickness of isolation pad assembly

NOTE: Floor to be level within 1/4". Place optional isolation pads under all four feet as shown. (No bolting to floor required.)

FIG. 1

LEVELING THE UNIT

Steam Units – Whether a unit is shipped as a complete one-piece shipment or as a separate two-piece shipment, a 1/2" fill-piece is attached under the feet of the lower shell at the generator steam entering end of unit. This should always be on the right hand side of the unit when looking at the micropanel. The 1/2" longitudinal inclination is to ensure that all possible condensate gets drained when the unit is shutdown in order to avoid “flushing” at unit start-up. For transverse leveling alignment, place a level on the top of the shell end sheet at each end of the unit.

Hot Water Units – There is no inclination requirement for hot water units. The longitudinal alignment of the unit should be checked by placing a level on the top center of the condenser shell. Transverse alignment should be checked by placing a level on the top of the shell end sheet at each end of the unit.

SHIPMENT

Model sizes 1A1 thru 10E3 are shipped as completely assembled units. Model sizes 12F1 thru 14F3 are shipped in two sections and are factory charged with dry nitrogen.

Units shipped in two sections are assembled at the factory to complete the piping and then are disassembled for ease of shipment. The generator/condenser shell is shipped as one assembly; the absorber/evaporator shell, heat exchanger, solution pump, refrigerant pump, vacuum pump/purge system, and micropanel/power panel are shipped as the other assembly.

On all units, whether they are one-piece assembly shipment or split shipment, have the the following parts as shipped loose: control valve (either steam or hot water), chilled or tower water flow switches, absolute pressure gauge, alcohol, heat conductive compound, 4 oz medical vial, vacuum pump hose, and various small fittings and fasteners to field assemble the above to the unit.

SOLUTION AND REFRIGERANT SHIPMENT

Starting with orders released after January 1, 1999 the procedure for ordering and shipping the solution and refrigerant is changing.

North America and Canada orders YORK Customer Service will place an order with the solution supplier and send a release form to the YORK service office responsible for the chiller start-up. The service office is then responsible for completing and forwarding the release form to the supplier 2 weeks before they require shipment of the solution and refrigerant. **The solution and refrigerant will then ship in barrels, direct from the solution supplier, to the jobsite.**

International orders, if solution is purchased with the IsoFlow™ chiller, YORK Customer Service will place an order with the solution supplier. The solution and refrigerant will ship in barrels with the chiller to the port for packaging and consolidation.

Please note the refrigerant is De-ionized water and will ship in barrels. Regular tap water can no longer be used as refrigerant. See page 42 for unit charge quantities.

MAJOR COMPONENT LOCATION

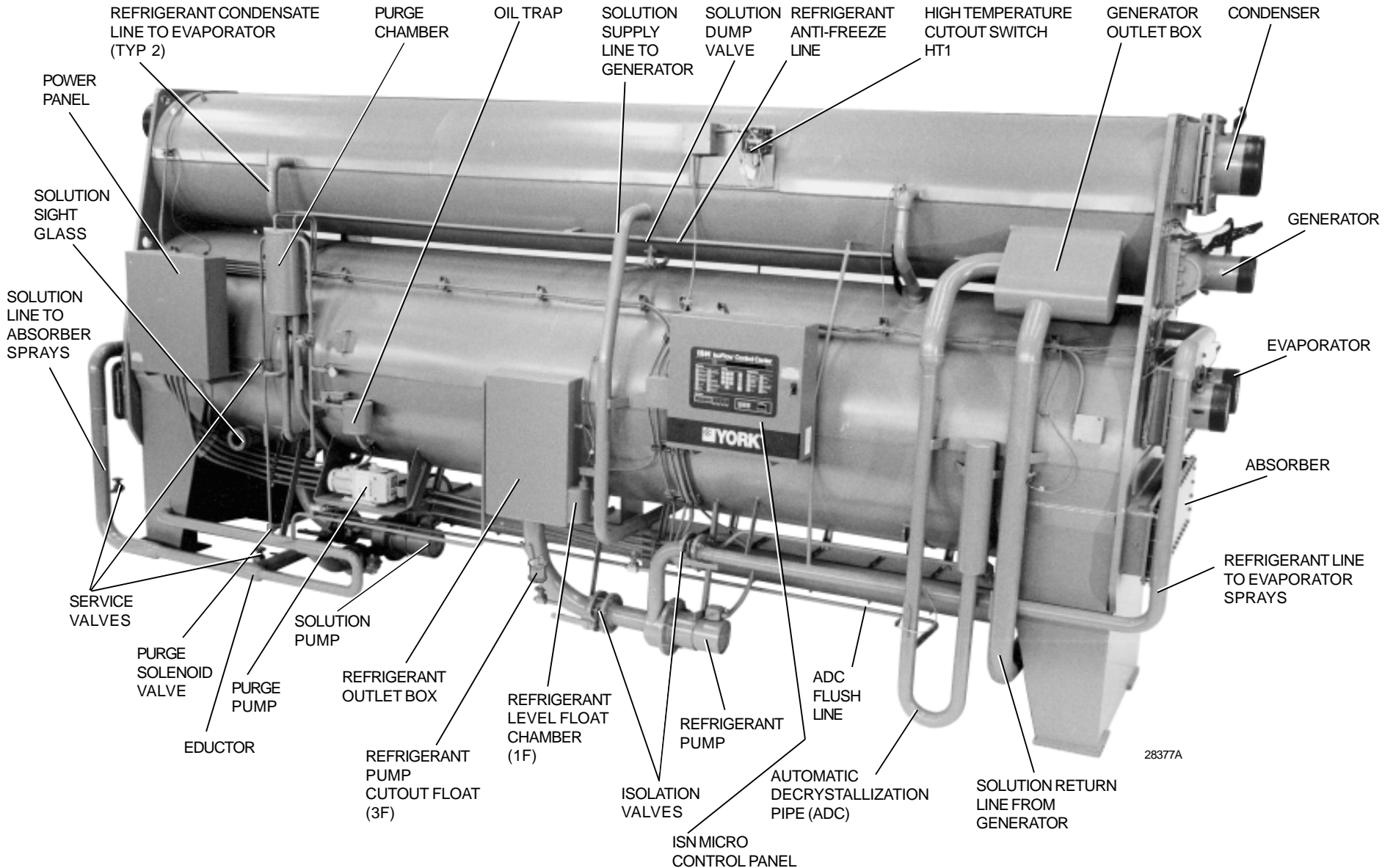
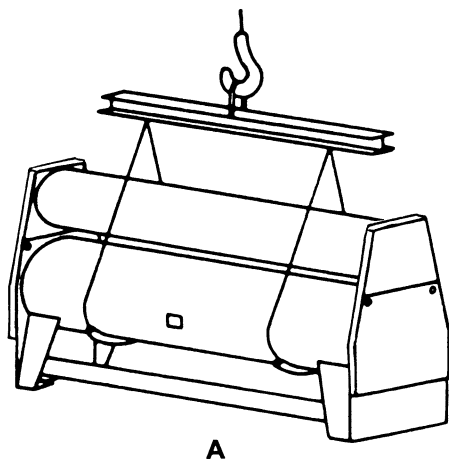
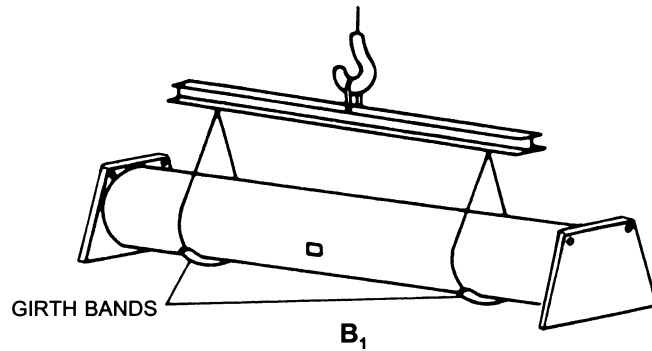

FIG. 2 – MAJOR COMPONENT LOCATIONS FOR ISOFLOW™ CHILLERS



A



GIRTH BANDS

B₁

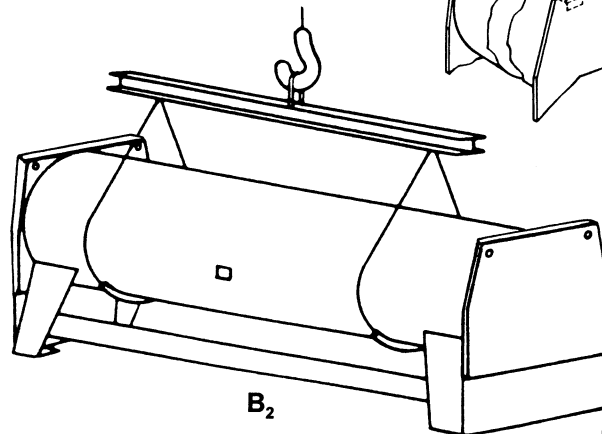
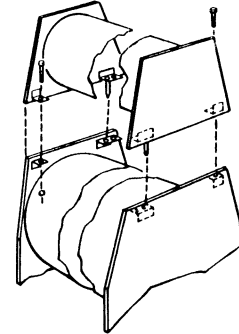

B₂

LD00937

FOR LIFTING A STANDARD ABSORPTION UNIT, **ONE SECTION SHIPMENT** (FIG. A) OR **TWO SECTION SHIPMENT** (FIG'S. B, & B₂) SLING VERTICALLY AT GIRTH BANDS AS INDICATED WITH TWO CHAINS OR CABLES. USE EXTREME CARE SO AS NOT TO SLING AGAINST, OR ON ANY PROJECTING BRACKETS, PIPES, TUBING, ETC. LENGTH OF SPREADER BAR MUST BE ADEQUATE TO SLING VERTICALLY.

WARNING

HOLES IN TUBE SHEETS ARE FOR TIE DOWN DURING SHIPMENT ONLY - DO NOT USE THESE HOLES FOR RIGGING.

FIG. 3

UNIT RIGGING

ONE PIECE UNIT SHIPMENT

For lifting the unit, sling vertically. Position slings around the unit, at the girth bands provided under the lower shell. Use extreme care so as not to sling against, or on any projecting brackets, pipes, fittings or any apparatus which may be damaged under the weight of the unit. **Do not lift the complete unit by slinging the upper shell or using the holes in the end sheets.** See Fig. 3 - A.

After rigging the unit to its final position, remove the skids before lowering the unit into position. Use shims as necessary so that the unit sits squarely on the foundation. While mounting bolts are not required, holes are provided for bolts in each mounting foot for securing the unit in areas known to experience earth tremors or seismically active areas.

TWO PIECE UNIT SHIPMENT

All units are available as a two piece shipment for easy of transportation and handling. Larger units (12F1 thru 14F3) are always shipped in two sections. Two piece

shipments are built such that the rigger can set the two sections together without disturbing the unit piping.

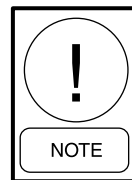

On multiple two-piece shipments, make sure the upper and lower shells are matched correctly. Match identification numbers are stamped on each shell end sheet. DO NOT MISMATCH THE UPPER AND LOWER SHELLS!

1. Installing the lower shell - Check the foundation and set the lower shell in position in the manner described for the complete assembly. Use proper jacks or rollers. See Fig. 3 -B.
2. Installing the upper shell - Disconnect the skids from the top shell assembly. Using slings around the top shell at the girth bands, hoist the top shell assembly into position above the bottom shell assembly. Use tapered pins at two opposite corners of the top shell to align the corner brackets as the top shell is lowered onto the bottom shell assembly. Install the four bolts at the corner brackets. See Fig. 3 - B.

TABLE 1 – UNIT WEIGHTS AND DIMENSIONS

| UNIT WEIGHTS AND DIMENSIONS | | | | | | | |
|-----------------------------|--------------------------------------|------------|-------------|---|-------------------------------|----------|--------------------------------|
| Model Unit | Overall Dimensions (Feet - Inches)** | | | *Maintenance clearance (feet - inches) (either end) | Approx. Shipping Weight (lbs) | | Approx. Operating Weight (lbs) |
| | Length | Width | Height | | Total | Max. Rig | |
| 1A1 | 12 - 2-1/2 | 5 - 1 | 7 - 7-1/4 | 10 - 8 | 8,900 | 8,700 | 10,900 |
| 1A2 | 14 - 2-1/2 | 4 - 4 | 7 - 7-1/4 | 12 - 8 | 9,800 | 9,700 | 12,100 |
| 2A3 | 16 - 2-1/2 | 4 - 4 | 7 - 7-1/4 | 14 - 8 | 10,800 | 10,600 | 13,500 |
| 2A4 | 18 - 2-1/2 | 4 - 4 | 7 - 7-1/4 | 16 - 8 | 11,700 | 11,500 | 14,500 |
| 2B1 | 16 - 2-1/2 | 4 - 10 | 8 - 7-3/4 | 14 - 8 | 13,400 | 13,300 | 17,400 |
| 3B2 | 18 - 2-1/2 | 4 - 10 | 8 - 7-3/4 | 16 - 8 | 14,800 | 14,600 | 18,800 |
| 3B3 | 20 - 2-1/2 | 4 - 10 | 8 - 7-3/4 | 18 - 8 | 16,200 | 16,000 | 20,900 |
| 4B4 | 22 - 2-1/2 | 4 - 10 | 8 - 7-3/4 | 20 - 8 | 17,600 | 17,400 | 23,100 |
| 4C1 | 18 - 2-1/2 | 5 - 5 | 9 - 10-3/4 | 16 - 8 | 18,500 | 18,200 | 25,100 |
| 5C2 | 20 - 2-1/2 | 5 - 5 | 9 - 10-3/4 | 18 - 8 | 20,200 | 19,900 | 27,800 |
| 5C3 | 22 - 2-1/2 | 5 - 5 | 9 - 10-3/4 | 20 - 8 | 21,800 | 21,500 | 30,000 |
| 6C4 | 24 - 8-1/2 | 5 - 5 | 9 - 10-3/4 | 23 - 2 | 23,500 | 23,200 | 32,500 |
| 7D1 | 20 - 2-1/2 | 6 - 6-1/4 | 11 - 7-3/4 | 18 - 8 | 28,700 | 28,400 | 39,400 |
| 7D2 | 22 - 2-1/2 | 6 - 6-1/4 | 11 - 7-3/4 | 20 - 8 | 32,200 | 31,900 | 43,700 |
| 8D3 | 24 - 8-1/2 | 6 - 6-1/4 | 11 - 7-3/4 | 23 - 2 | 35,700 | 35,400 | 48,000 |
| 8E1 | 22 - 6-1/4 | 7 - 2-1/4 | 12 - 7 | 20 - 8 | 39,000 | 38,600 | 53,100 |
| 9E2 | 25 - 0-1/4 | 7 - 2-1/4 | 12 - 7 | 23 - 2 | 43,400 | 43,000 | 59,100 |
| 10E3 | 27 - 6-1/4 | 7 - 2-1/4 | 12 - 7 | 25 - 8 | 48,500 | 48,100 | 65,600 |
| 12F1 | 25 - 0-1/4 | 7 - 10-1/4 | 13 - 10-1/2 | 23 - 2 | 55,100 | 44,400 | 78,300 |
| 13F2 | 27 - 6-1/4 | 7 - 10-1/4 | 13 - 10-1/2 | 25 - 8 | 59,700 | 48,100 | 86,000 |
| 14F3 | 30 - 6-1/4 | 7 - 10-1/4 | 13 - 10-1/2 | 28 - 2 | 63,700 | 50,600 | 90,600 |

NOTES:

- * Maintenance clearance for: 1. End opposite tube maintenance - 7'-0" minimum
2. Front and rear of unit 3'-0" minimum

** Add 8 inches to height dimension for skid allowances on assembled units and to each selection on units shipped knocked down.

UNIT ASSEMBLY CONNECTIONS FOR TWO-PIECE SHIPMENTS

Units shipped in two pieces are charged with nitrogen at a pressure of approximately 2 psig. This charge should be retained until the unit piping is to be completed, at which time nitrogen pressure will be relieved. The nitrogen is relieved from the bottom shell through one of the charging/sample valves located on the unit piping. For the top shell, relieve the nitrogen charge through a coupling plug. Any threaded plugs removed must be re-installed by using Loctite thread sealer 565. **Do not use teflon tape for thread sealing on any YORK absorption machine.**

Welded connections – On two-piece shipment units welding is necessary to complete many connections. These lines usually have closure caps or flat plates covering the openings. **All cutting or welding on any absorption chiller must be done in accordance to YORK form 155.17-M3.**

The unit model number for each unit is stamped on the unit data plate which is attached to the side of the YORK micropanel. Match the model you are assembling with the correct assembly drawing shown in Figs. 4 thru 9.

Carefully follow the notes on each figure when assembling the top shell to the bottom shell.

All piping must be checked and cleaned of all dirt and foreign material. **DO NOT** use oil on internal surfaces of the system, including shipped-loose filler pieces. Once inside the system oil can seriously harm unit performance.

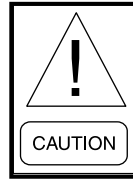

Special care must be exercised to keep dirt and other foreign materials out of the pipes while the unit is open and during the process of opening the unit. Caps and flat plates should be removed just prior to assembly. If there is any delay in the work and the pipes will be open for a number of hours, the ends of the pipe must be taped shut and a nitrogen blanket applied to the unit. DO NOT USE ANY BACK-UP RINGS WHEN WELDING PIPES.

NOTES:

- 1.- 5 (FIVE) PIECES ARE SHIPPED LOOSE FOR MODELS 1A1 & 1A2
- 7 (SEVEN) PIECES ARE SHIPPED LOOSE FOR MODELS 2A3 & 2A4.
- 1 (ONE) REDUCTION No. 023-02462-000
- 1 (ONE) REDUCTION No. 023-02459-000
- 1 (ONE) PIPE 10" LENGTH No. 066R11530-000 2A3 & 2A4.
- 1 (ONE) PIPE 10" LENGTH No. 066R11526-000 2A3 & 2A4.
- 1 (ONE) PIPE 10" LENGTH No. 066R11530-000 1A1 & 1A2.
- 1 (ONE) SCREWS & NUTS PACKET FOR ASSEMBLING THE ANGLES (SUPPORTS OF THE SHELL) No. 021-01518-000 & 021-14232-000.
- 1 (ONE) PIPE 7" LENGTH No. 066R12499-000 1A1 & 1A2.
- 2 (TWO) PIPES 7" LENGTH No. 066R12499-000 2A3 & 2A4.
- 2.- USE BOLTS & NUTS, PROVIDED IN MOUNTING ANGLES, TO ASSEMBLE SHELLS.
- 3.- PANELS AND OTHER ELECTRICAL INSTALLATIONS MAY HAVE TO BE REMOVED IF SPACE IS LIMITED.
- 4.- GRIND OFF PIPE CAPS (DO NOT CUT INTO PIPE).
- 5.- BEVEL BOTH SIDES OF JOINTS (75°).
- 6.- WELD ALL JOINTS (CARE SHOULD BE EXERCISED SO THAT NO DIRT, SCALE, GREASE, ETC. IS ALLOWED TO ENTER PIPING)
- 7.- INSTALLATION INSTRUCTIONS AND PRODUCT DRAWING MUST BE REFERRED TO WHEN MAKING FIELD ASSEMBLY.

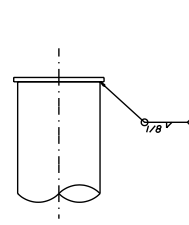

DETAIL "A"

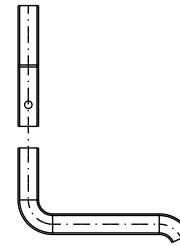

DETAIL "B"

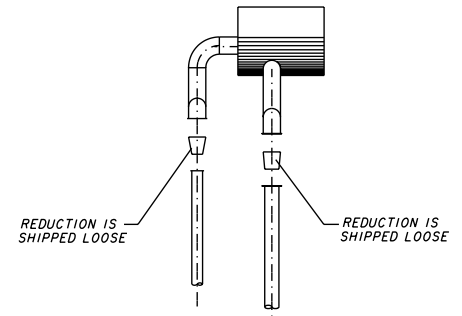

DETAIL "C"

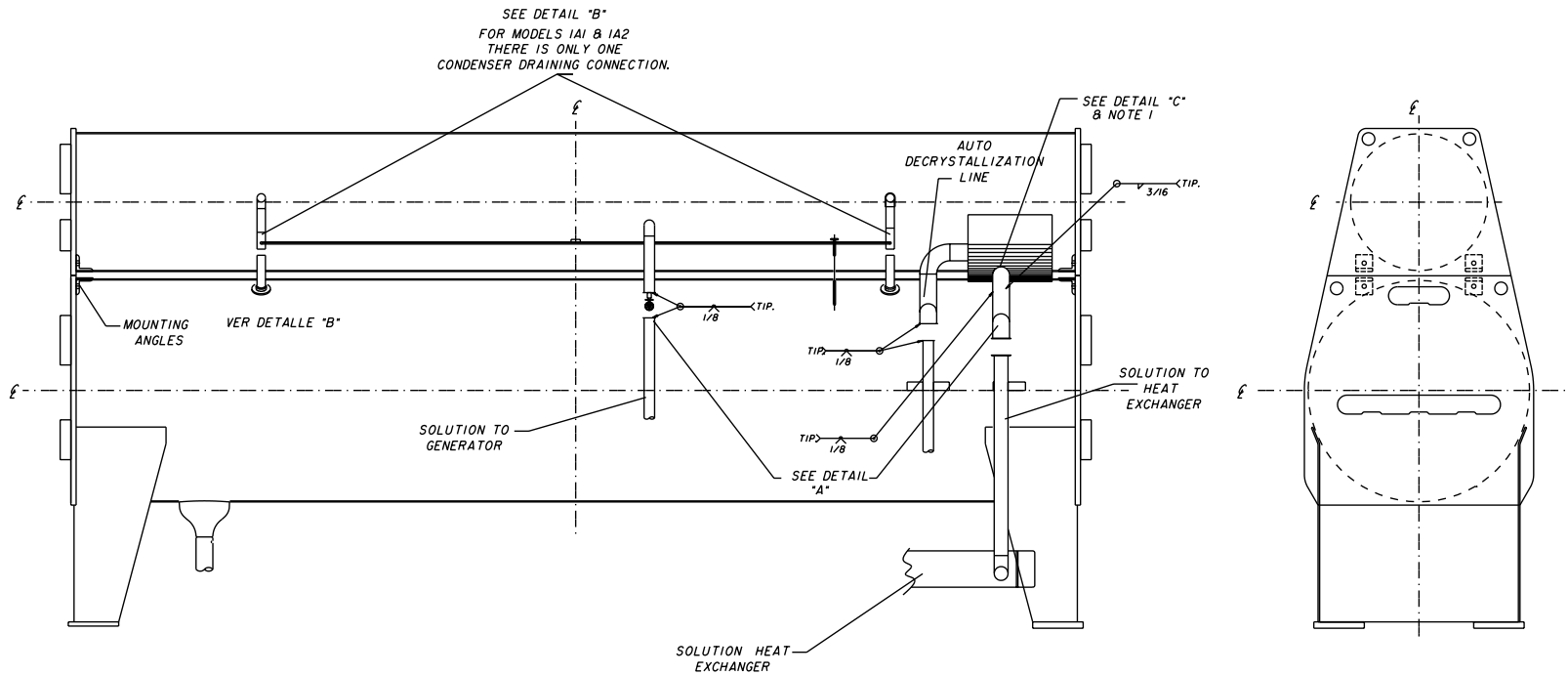

FIG. 4 - UNIT ASSEMBLY FOR MODELS 1A1 THRU 2A4

LD04712

NOTES:

- 1.- 7 (SEVEN) PIECES ARE SHIPPED LOOSE
 - 1 (ONE) REDUCTION No. 023-09892-000.
 - 1 (ONE) PIPE 10" LENGTH No. 066RI1537-000
 - 1 (ONE) PIPE 10" LENGTH No. 066RI1526-000.
 - 1 (ONE) SCREWS & NUTS PACKET FOR ASSEMBLING THE ANGLES (SUPPORTS OF THE SHELL) No. 021-01598-000 & 021-11154-000
 - 2 (TWO) PIPES 7" LENGTH No. 066RI2499-000.
 - 1 (ONE) PIPE 6" LENGTH No. 066RI2612-000.
- 2.- USE BOLTS & NUTS, PROVIDED IN MOUNTING ANGLES, TO ASSEMBLE SHELLS.
- 3.- PANELS AND OTHER ELECTRICAL INSTALLATIONS MAY HAVE TO BE REMOVED IF SPACE IS LIMITED.
- 4.- GRIND OFF PIPE CAPS (DO NOT CUT INTO PIPE).
- 5.- BEVEL BOTH SIDES OF JOINTS (75°).
- 6.- WELD ALL JOINTS (CARE SHOULD BE EXERCISED SO THAT NO DIRT, SCALE, GREASE, ETC. IS ALLOWED TO ENTER PIPING)
- 7.- INSTALLATION INSTRUCTIONS AND PRODUCT DRAWING MUST BE REFERRED TO WHEN MAKING FIELD ASSEMBLY.

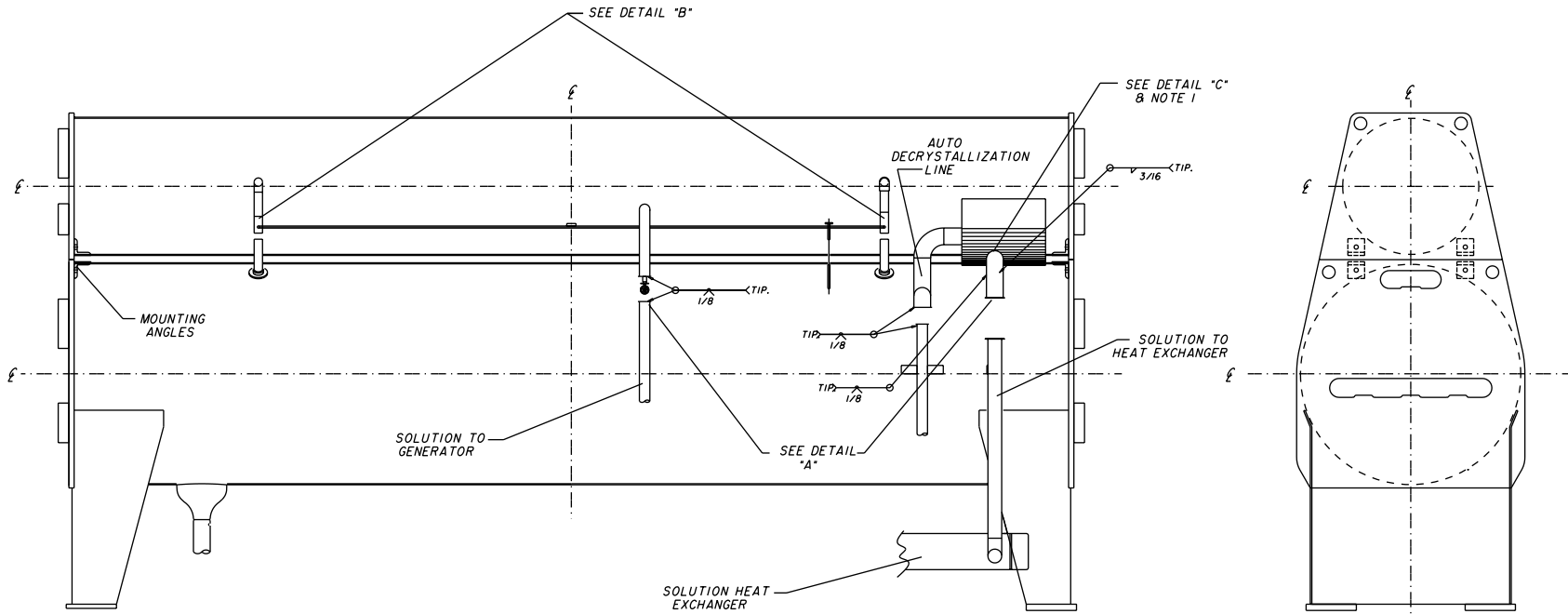
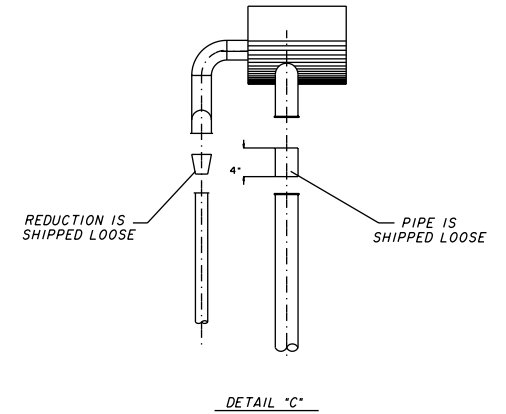
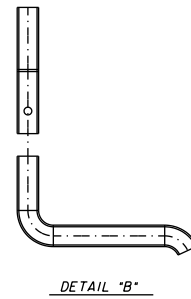
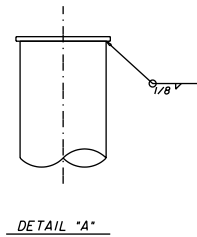

FIG. 5 – UNIT ASSEMBLY FOR MODELS 2B1 THRU 4B4

LD04713

- NOTES:
- 1.- 7 (SEVEN) PIECES ARE SHIPPED LOOSE.
 - 1 (ONE) REDUCTION No. 023-02490-000.
 - 1 (ONE) PIPE 10" LENGTH No. 066R11545-000.
 - 1 (ONE) PIPE 10" LENGTH No. 066R11526-000.
 - 1 (ONE) SCREWS & NUTS PACKET FOR ASSEMBLING THE ANGLES (SUPPORTS OF THE SHELL) No. 021-01598-000 & 021-11154-000.
 - 2 (TWO) PIPES 7" LENGTH No. 066R12500-000.
 - 1 (ONE) PIPE 5" LENGTH No. 066R12613-000.
 - 2.- USE BOLTS & NUTS, PROVIDED IN MOUNTING ANGLES, TO ASSEMBLE SHELLS.
 - 3.- PANELS AND OTHER ELECTRICAL INSTALLATIONS MAY HAVE TO BE REMOVED IF SPACE IS LIMITED.
 - 4.- GRIND OFF PIPE CAPS (DO NOT CUT INTO PIPE).
 - 5.- BEVEL BOTH SIDES OF JOINTS (75°).
 - 6.- WELD ALL JOINTS (CARE SHOULD BE EXERCISED SO THAT NO DIRT, SCALE, GREASE, ETC. IS ALLOWED TO ENTER PIPING).
 - 7.- INSTALLATION INSTRUCTIONS AND PRODUCT DRAWING MUST BE REFERRED TO WHEN MAKING FIELD ASSEMBLY.

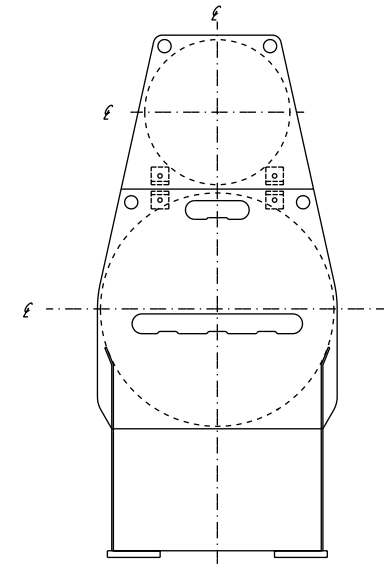
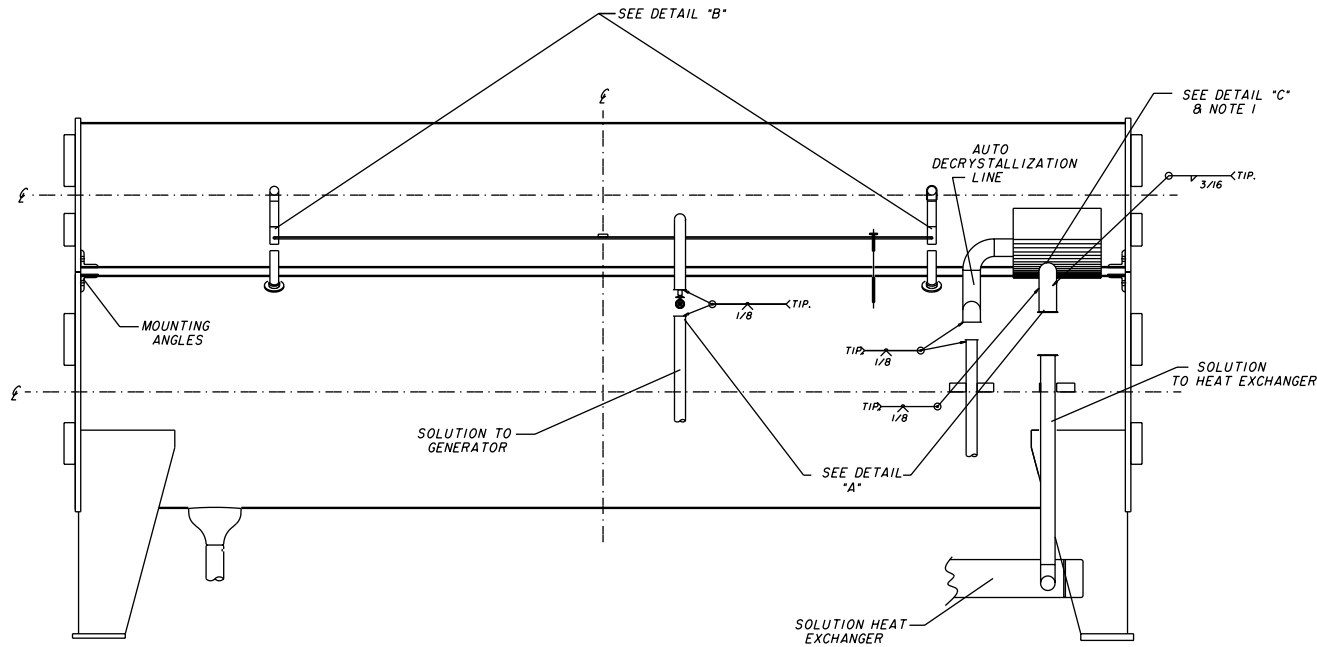
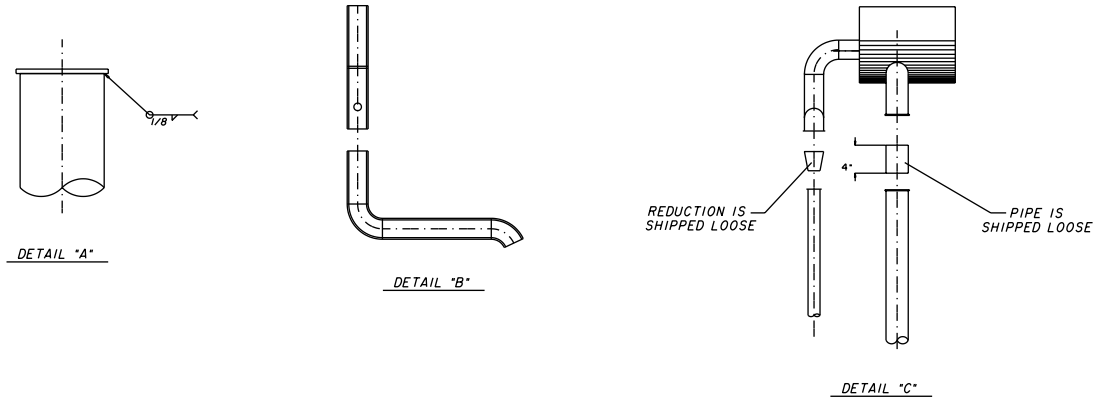

FIG. 6 – UNIT ASSEMBLY FOR MODELS 4C1 THRU 6C4

LD04714

NOTES:

- 1.- 8 (EIGHT) PIECES ARE SHIPPED LOOSE.
 - 1 (ONE) REDUCTION No. 023-02507-000.
 - 1 (ONE) ELBOW No. 023-02475-000.
 - 1 (ONE) PIPE 10" LENGTH No. 066R11545-000.
 - 1 (ONE) PIPE 10" LENGTH No. 066R11526-000.
 - 1 (ONE) REDUCTION No. 023-02510-000.
 - 1 (ONE) SCREWS & NUTS PACKET FOR ASSEMBLING THE ANGLES (SUPPORTS OF THE SHELL) No. 021-02097-000 & 021-00504-000.
 - 2 (TWO) PIPES 7" LENGTH No. 066R12500-000.
- 2.- USE BOLTS & NUTS, PROVIDED IN MOUNTING ANGLES, TO ASSEMBLE SHELLS.
- 3.- PANELS AND OTHER ELECTRICAL INSTALLATIONS MAY HAVE TO BE REMOVED IF SPACE IS LIMITED.
- 4.- GRIND OFF PIPE CAPS (DO NOT CUT INTO PIPE).
- 5.- BEVEL BOTH SIDES OF JOINTS (75°).
- 6.- WELD ALL JOINTS (CARE SHOULD BE EXERCISED SO THAT NO DIRT, SCALE, GREASE, ETC. IS ALLOWED TO ENTER PIPING).
- 7.- INSTALLATION INSTRUCTIONS AND PRODUCT DRAWING MUST BE REFERRED TO WHEN MAKING FIELD ASSEMBLY.

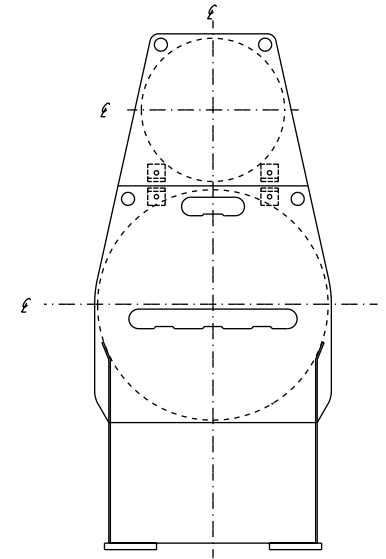
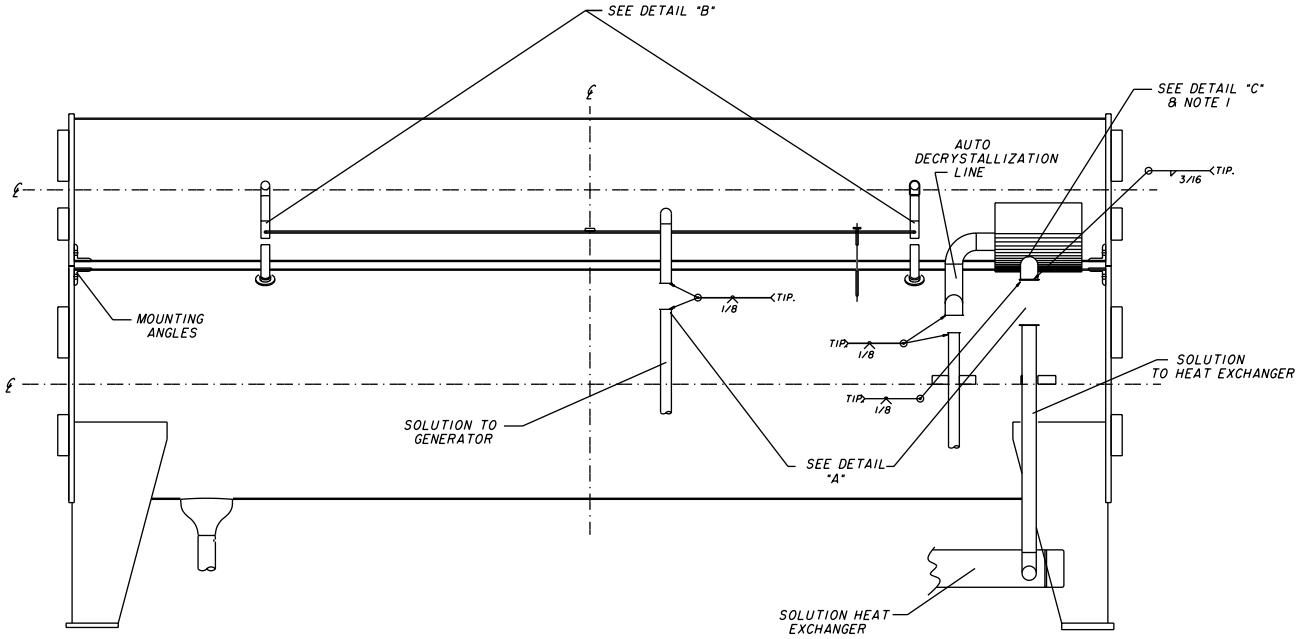
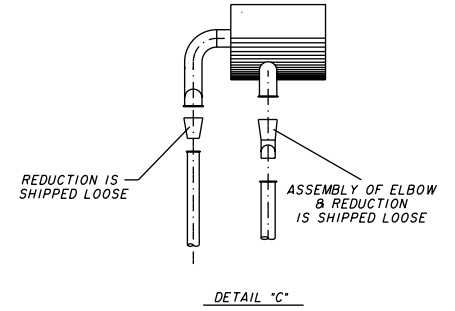
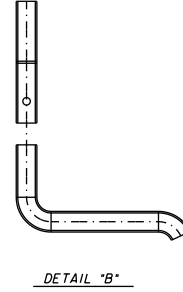
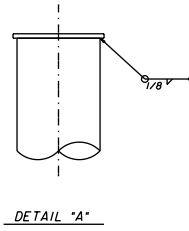
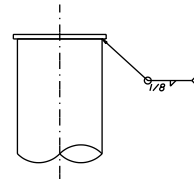

FIG. 7 – UNIT ASSEMBLY FOR MODELS 7D1 THRU 8D3

LD04715

NOTES:

- 1.- 8 (EIGHT) PIECES ARE SHIPPED LOOSE.
 - 1 (ONE) REDUCTION No. 023-02509-000.
 - 1 (ONE) REDUCTION No. 023-02527-000.
 - 1 (ONE) ELBOW No. 023-02495-000.
 - 1 (ONE) PIPE 10" LENGTH No. 066R11526-000.
 - 1 (ONE) PIPE 10" LENGTH No. 066R11527-000.
 - 2 (TWO) PIPES 8" LENGTH No. 067-82917-000.
 - 1 (ONE) SCREWS & NUTS PACKET FOR ASSEMBLING THE ANGLES (SUPPORTS OF THE SHELL) No. 021-02097-000 & 021-00504-000.
- 2.- USE BOLTS & NUTS, PROVIDED IN MOUNTING ANGLES, TO ASSEMBLE SHELLS.
- 3.- PANELS AND OTHER ELECTRICAL INSTALLATIONS MAY HAVE TO BE REMOVED IF SPACE IS LIMITED.
- 4.- GRIND OFF PIPE CAPS (DO NOT CUT INTO PIPE).
- 5.- BEVEL BOTH SIDES OF JOINTS (75°).
- 6.- WELD ALL JOINTS (CARE SHOULD BE EXERCISED SO THAT NO DIRT, SCALE, GREASE, ETC. IS ALLOWED TO ENTER PIPING).
- 7.- INSTALLATION INSTRUCTIONS AND PRODUCT DRAWING MUST BE REFERRED TO WHEN MAKING FIELD ASSEMBLY.



DETAIL "A"

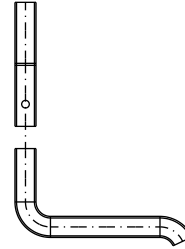

DETAIL "B"

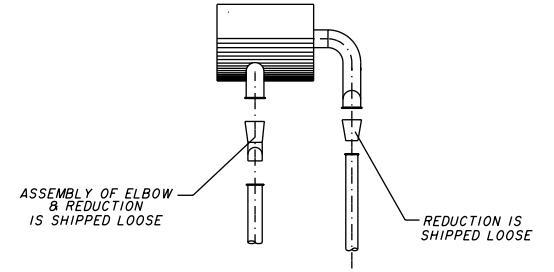

DETAIL "C"

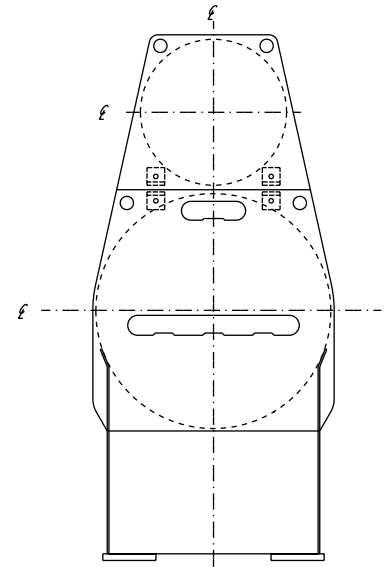
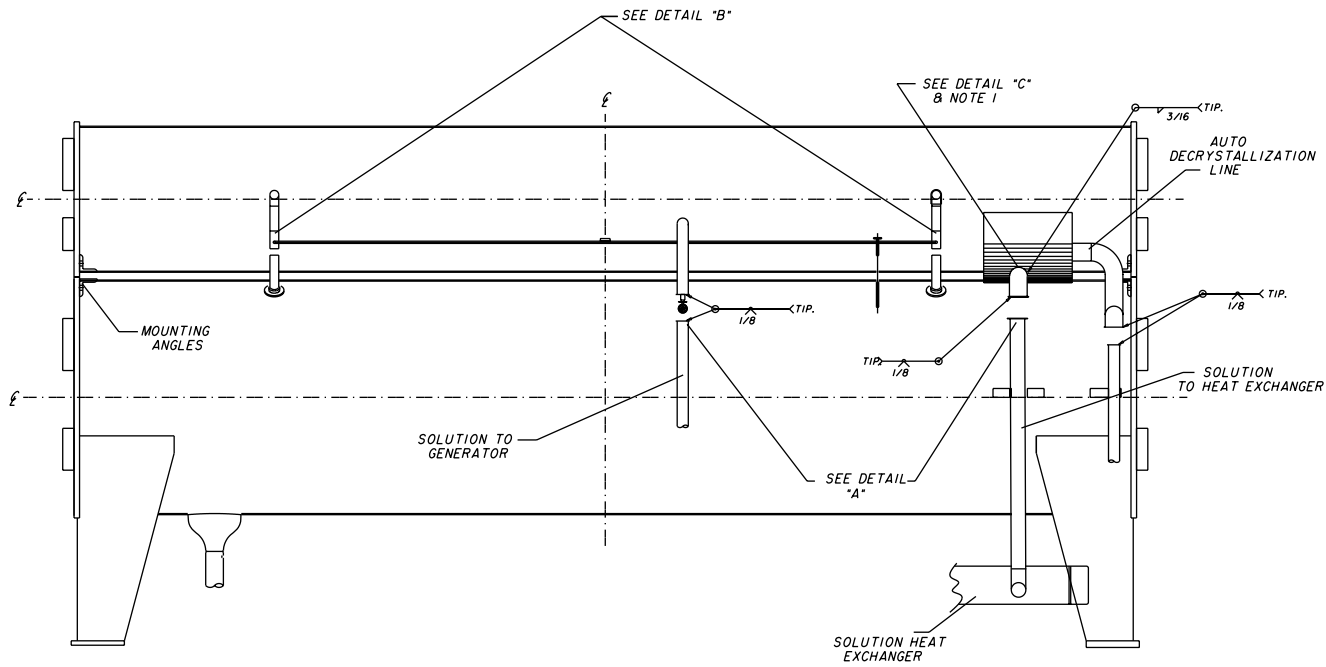

FIG. 8 - UNIT ASSEMBLY FOR MODELS 8E1 THRU 10E3

LD04716

- NOTES:
- 1.- USE BOLTS & NUTS, PROVIDED IN MOUNTING ANGLES, TO ASSEMBLE SHELLS.
 - 2.- PANELS AND OTHER ELECTRICAL INSTALLATIONS MAY HAVE TO BE REMOVED IF SPACE IS LIMITED.
 - 3.- GRIND OFF PIPE CAPS AT A, B, C, D & E (DO NOT CUT INTO PIPE).
 - 4.- BEVEL BOTH SIDE OF JOINTS AT "A". 75°.
 - 5.- WELD ALL JOINTS (CARE SHOULD BE EXERCISED SO THAT NO DIRT, SCALE, GREASE, ETC. IS ALLOWED TO ENTER PIPING)
 - 6.- INSTALLATION INSTRUCTIONS AND PRODUCT DRAWING MUST BE REFERRED TO WHEN MAKING FIELD ASSEMBLY.
 - 7.- 8 (EIGHT) FILL PIECES, TWO (2) REDUCERS, TWO (2) ELBOWS & FOUR (4) PIPES ARE SHIPPED LOOSE.

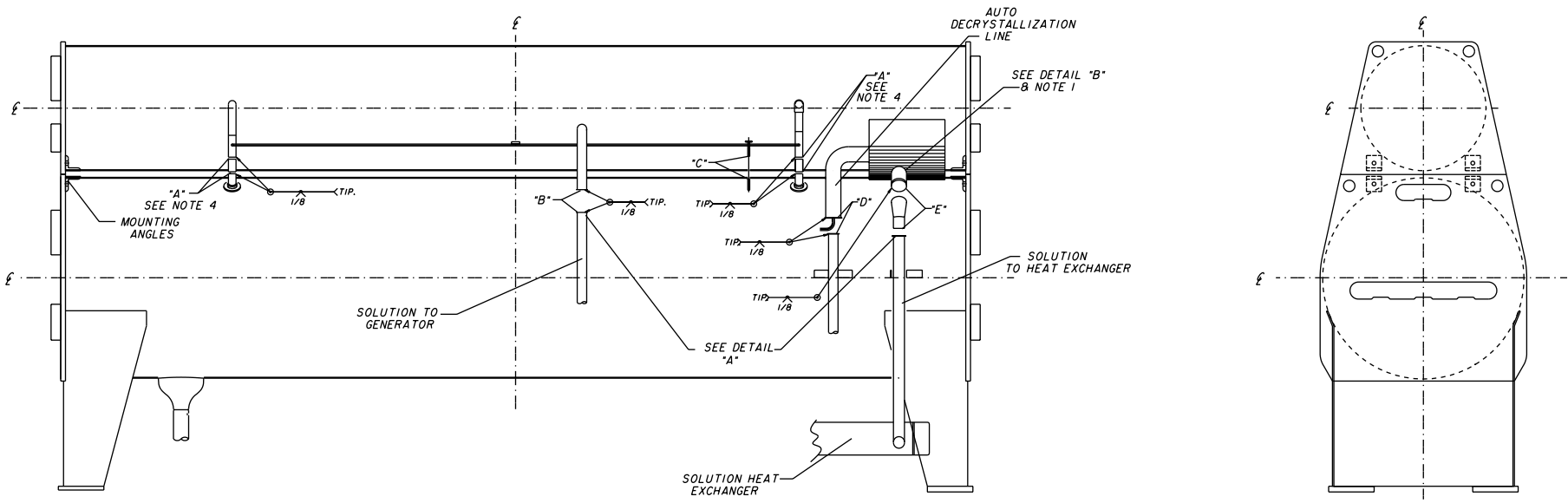
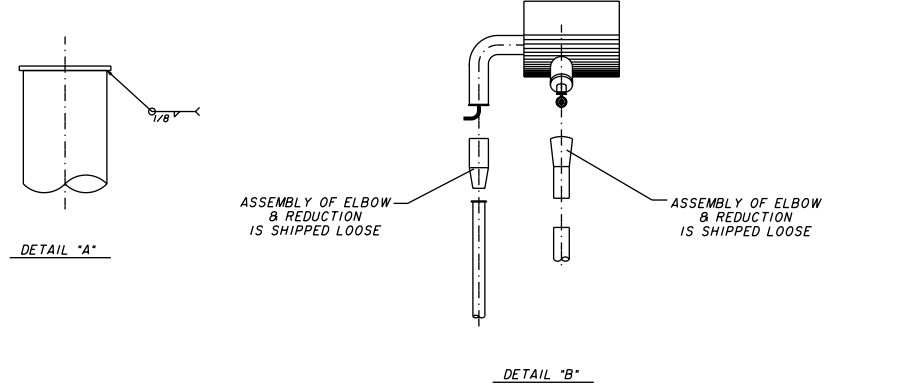

FIG. 9 – UNIT ASSEMBLY FOR MODELS 12F1 THRU 14F3

LD04717

INSTALLING THE ABSOLUTE PRESSURE GAUGE

The absolute pressure gauge is shipped separately for field installation. Mount the gauge on the gauge bracket which is located on the lower shell of the unit adjacent to the purge piping. Use #10-24 UNC x 1 inch long flat head machine screws and #10-24 UNC hex nuts. Make sure the gauge is absolutely vertical by placing a level on the side edge of the gauge before tightening the mounting screws. The gauge can be connected to the manometer isolation hand valve via tubing. When doing so, make sure the hand valve is in the closed position.

COMPLETING THE PURGE PUMP CONNECTIONS

The purge pump should already be mounted on the side of the unit with a special adaptor fitting, tee and ball valve installed at the discharge port of the purge pump. The suction port of the purge pump must be connected to the oil trap canister connection which is located above the purge pump. As part of the unit ship loose parts, there should be two hose clamps and a length of wire reinforced clear 3/4" I.D. tubing. Use this tubing and clamps to complete the connection between the purge pump suction port and the oil trap.

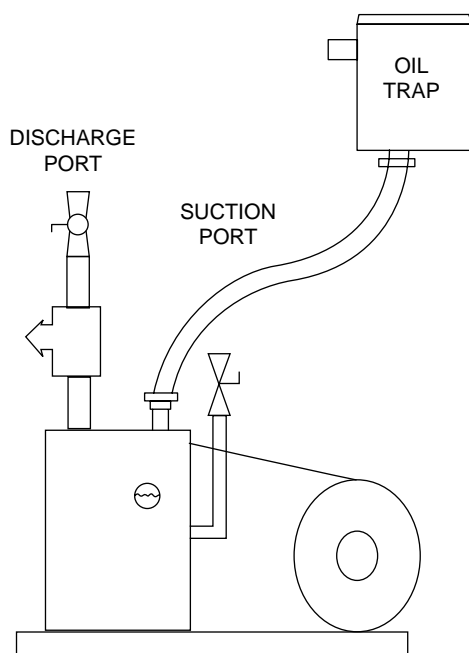

LD04564

FIG. 10 – PURGE PUMP

UNIT WATER PIPING

When the assembly of the unit is complete, and unit is level, the condenser water and chilled water piping may be made.

As standard, the unit nozzles will be provided with victaulic connections suitable for 150 PSIG DWP ANSI flanges for 150 or 300 PSIG DWP are provided only as an option. The piping must be installed in accordance with accepted piping practice and any applicable local piping codes. Provide adequate temperature and pressure wells or taps on all supply and return piping.



All water piping must be adequately supported and braced independent of the chiller. No strain is to be placed on the unit nozzles and/or connection flanges.

The piping should be arranged with offsets for flexibility, and adequately supported and braced independently of the unit to avoid strain on the unit and vibration transmission. Hangers must allow for alignment of pipe. Isolators (by others) in the piping are not necessary but may be desirable, and may be required by customer specifications.

Upon completion of piping, a connection in each line as close to the unit as possible should be opened, by removing the flange bolts or coupling and checked for piping alignment. If any of the bolts are bound in their holes, or if the connection springs are out of alignment, the misalignment must be corrected by properly supporting the piping or by applying heat to anneal the pipe.

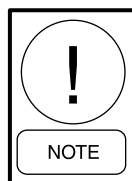

If the piping is annealed to relieve stress, the inside of the pipe must be cleaned of scale before it is finally bolted in place.

Inlet and outlet nozzle connections are identified by labels placed adjacent to each nozzle. Provide adequate temperature and pressure wells or taps on all supply and return piping. A chilled water flow switch is supplied as a ship loose item, which must be installed in either the supply or return chilled water circuit close to the unit. See Fig. 11. YORK highly recommends always mounting the flow switches in a horizontal length of pipe with the switch in a vertical position. It is not recommended to mount the flow switches in a vertical pipe with an upward flow due to the fact that minimum flow may not be substantial enough to lift the switch's paddle.

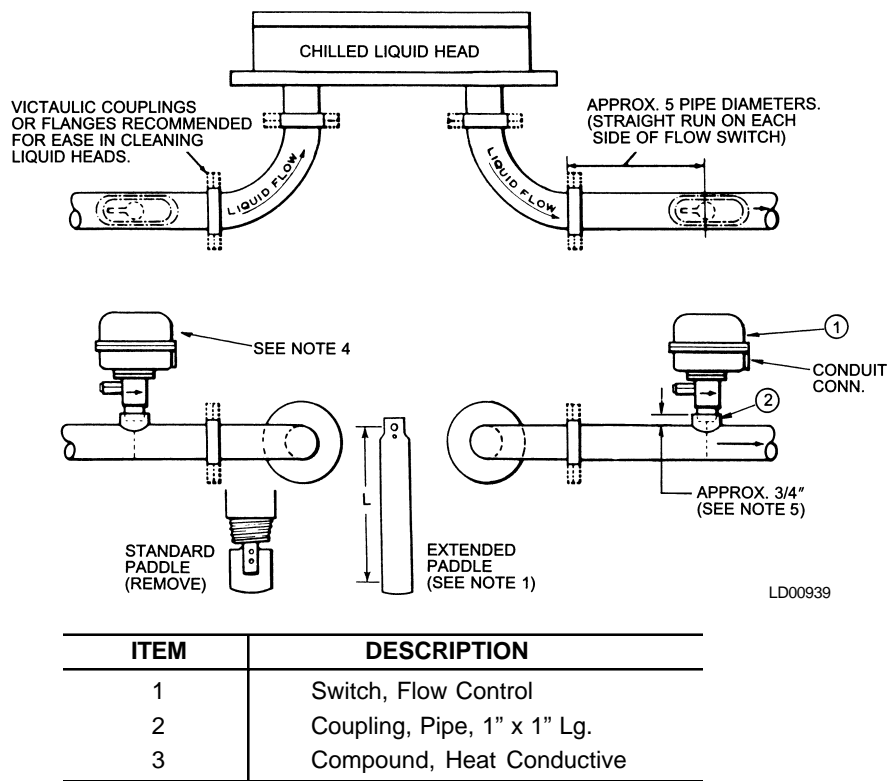

NOTES:

1. Adjust the Flow Switch Paddle to the size of the pipe in which it is to be used. Trim extended paddle to the "L" dimension as follows:

| DIAMETER OF PIPE (INCHES) | "L" DIMENSION (INCHES) |
|---------------------------|------------------------|
| 5 | 4-5/8 |
| 6 | 5-5/8 |
| 8 AND LARGER | FULL PADDLE |

2. The Flow Switch is to be installed and upright, as shown.
3. Screw the Flow Switch in position so that the paddle is at a right angle to the liquid flow. (Arrow mark on side of casting must point in same direction as liquid flow.)
4. The Flow Switch can be installed in either the inlet flow or outlet flow connections.
5. Before installing Item ②, make sure it is 1 inch long maximum.

| ITEM | DESCRIPTION |
|------|-----------------------------|
| 1 | Switch, Flow Control |
| 2 | Coupling, Pipe, 1" x 1" Lg. |
| 3 | Compound, Heat Conductive |

FIG. 11 – INSTALLATION OF FLOW SWITCH

A condenser and/or hot water flow switch is shipped only as an order option but must be used in each installation. See unit shipping papers if these switches are supplied.

Foreign objects which could lodge in, or block flow through, the cooler and absorber tubes must be cleaned or flushed before being connected to the chiller pumps, or other equipment.

STRAINERS

Permanent strainers (supplied by others) are required in both the cooler and tower water circuits to protect the chiller water coils and controls, etc. The strainer should be a #10 mesh and be installed in the entering chilled water line, directly upstream of the chiller. Water piping circuits should be arranged so that the pumps discharge to maintain essentially constant chilled and tower water flows through the unit at all load conditions. If pumps discharge through the chiller, the strainer may be located upstream from the pumps to protect both pump and chiller. (Piping between strainer, pump

and chiller must be very carefully cleaned before start-up.) If pumps are remotely installed from chiller, strainers should be located directly upstream of the chiller.

ABSORBER AND CONDENSER WATER PIPING

The absorber and condenser water piping should be in accordance with the drawings for the specific system. The tower water must be piped into the absorber nozzle and out the condenser nozzle. A factory installed well is located in the absorber inlet nozzle on the absorber inlet water box. This nozzle should also have an inlet sticker attached near it to help the installer identify which nozzle is the inlet. It is also necessary to field fabricate the cooling water crossover pipe from the absorber to the condenser, the material must be field supplied to do this. This pipe diameter must be the same size as the other tower water connections, and have the same pressure rating. Arrange the crossover pipe so that cleaning of the absorber, evaporator and condenser tubes can easily be accessible.

See Fig. 12 for tower water piping.

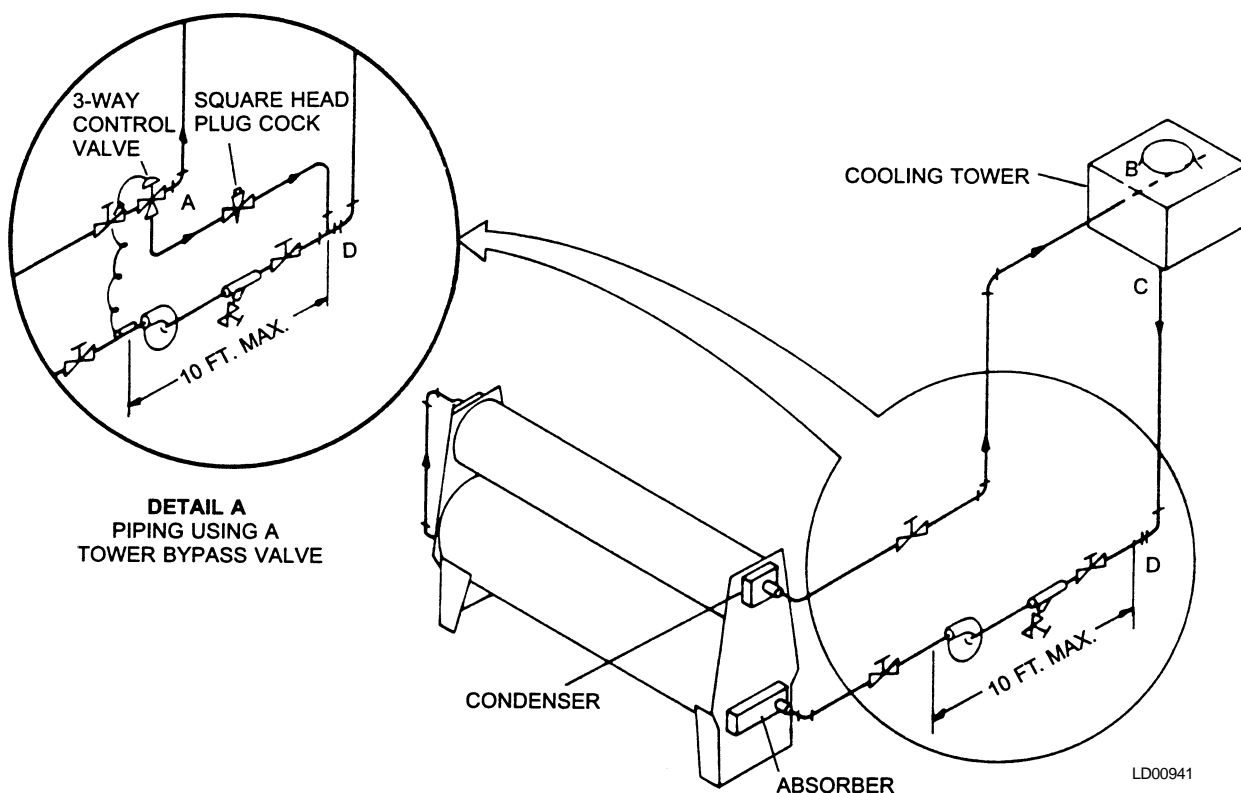

FIG. 12 – TYPICAL COOLING TOWER PIPING

RUPTURE DISK AND RELIEF PIPING (HOT WATER UNITS ONLY)

Only the IsoFlow™ absorption chillers that operate on hot water require a rupture disk. This disk is supplied by the factory and is sent with the chiller ship loose parts. The rupture disk is made of a carbon graphite material that will rupture should the unit pressure exceed 15.0 PSIG. This will protect the unit should there ever be a tube rupture or the extremely unlikely case of abnormally high refrigerant vapor pressure inside the unit. The disk mounts between two neoprene gaskets (also shipped loose) and two steel flanges. Use graphite on the screw threads and torque the screws that hold the rupture disk to a max of 15-1/2 ft.-Lbs.

On the 4" schedule 40 stub provided, butt weld other sections of 4" pipe and route piping over and down to terminate approximately 10"- 12" above a floor drain. Use adequate pipe supports and stand offs to ensure that no weight from the relief piping is bearing on the rupture disk or its flange. All relief piping must be installed in accordance with local, state or federal codes.

INLET STEAM PIPING (REFER TO FIG. 13)

The design level "B" IsoFlow™ absorption chiller is designed for a maximum pressure of 15 PSIG (103 kPa), with a maximum steam temperature of 337°F (169°C). All steam field piping should be installed in accordance with any local, state or federal codes that may apply. Piping should be adequately supported and braced independent of the chiller. The support system must account for the expansion and contraction of the steam piping, avoiding the imposition of strain on chiller components. Steam piping should be designed in accordance with good engineering practice.

A typical steam piping diagram is laid out in Fig. 13. The steam supply may be either low pressure steam or high pressure steam reduced to low pressure steam. Both steam supply and condensate pipes must be properly sized and pitched to prevent liquid hammering. Steam mains should be sized in accordance with the required steam flow and acceptable pressure drop. Wherever possible, the steam supply line to the absorp-

tion unit should be taken off the main steam supply line from the top side to minimize the possibility of condensate carry-over. Additional consideration should be given to steam flow velocity, especially in those applications where noise is a factor. Generally speaking, steam velocities up to 6,000 fpm (30 m/s) will not produce an objectionable noise level. Always pitch steam supply line to prevent hammering.

The factory supplied steam control valve must be installed 4 to 10 feet (1.2 m to 3.0 m) from the generator steam inlet flange in order to minimize the pressure drop from the valve exit to the generator inlet.

The following is a description of each component on the steam entering side of the steam piping. Refer to Fig. 13 for the actual recommended component location.

INLET STEAM PIPING COMPONENTS

Manual Block Valve – This valve is installed to manually shut off the steam supply to the unit, thus allowing ease of serviceability if required.

Desuperheater – A desuperheater must be used upstream of all controls when the steam supply has a temperature in excess of 337° F (169°C). This is for all design level “B” units only. If the unit is not a design level “B”, and it was not sold for Hi-temp. generator applications then the maximum design steam temperature would be 285°F (140°C). The flow of coolant to the desuperheater should be automatically controlled to maintain a constant steam supply temperature to the absorption unit within the limits specified. Suitable automatic means should be provided to remove any condensate which may accumulate. Test thermowells should be provided in the steam inlet and outlet from the desuperheater to check its operation.

Steam Strainer – A fine mesh steam strainer (#50 mesh) is used to capture any impurities in the steam supply line. These impurities may manifest themselves in the form of dirt, rust, or precipitates. This strainer will prevent the chiller system components from getting plugged. Plugged components will reduce system capacity and increase maintenance costs. A pressure gauge must be installed just before and after the steam strainer. If the pressure drop as read from these two gauges increases to an unacceptable level, the steam strainer should be removed and cleaned.

Steam Separator – The steam separator is installed in the steam supply line and is used to separate any liquid present in the steam. This condensate liquid would normally be piped through a steam trap back to the condensate tank. The steam trap will prevent any steam from blowing through the separator into the condensate return system. The use of a steam separator and trap will allow only dry steam to enter the unit at all times.

All IsoFlow™ absorption chillers must operate with only dry steam going into the generator. If dry steam can be supplied without the use of a steam separator, then it is not necessary to install one. In cases where the chiller is located close to the boiler or is supplied with superheat, the steam reaching the chiller may already be dry. However, since any liquid present in the steam supply entering the generator will reduce the heat input, it is important to include a steam separator - unless it is truly not necessary.

Pressure Reducing Valve – A pressure reducing valve must be used if the steam pressure to the chiller is greater than 15 PSIG (103 kPa). For applications where the steam supply pressure is known to fluctuate, it is recommended that a steam pressure regulating valve be used.

When needed, a steam pressure reducing valve suitable for dead-end service must be provided in the steam supply piping ahead of the steam control valve. This pressure reducing valve should be sized on the basis of the pressure drop and absorption unit full load steam flow requirements, not on the basis of steam supply pipe size (which can result in an oversized valve). The pressure reducing valve should be provided with stop valves on both inlet and outlet and a full size bypass with a globe valve to permit manual operation during maintenance.

Two pressure reducing valves, one large and one small, piped in parallel may be desirable for those applications with continued operation at low loads or where highly variable upstream pressures exist. The smaller valve would be set at a slightly higher pressure than the large valve so it will stay open at low flow rates while the large valve closes, thus protecting the seat of the larger valve. The use of two steps of steam pressure reduction may be desirable on applications with pressure differentials in excess of 100 PSIG (690 kPa). The noise generated in a single step of reduction may be objectionable.

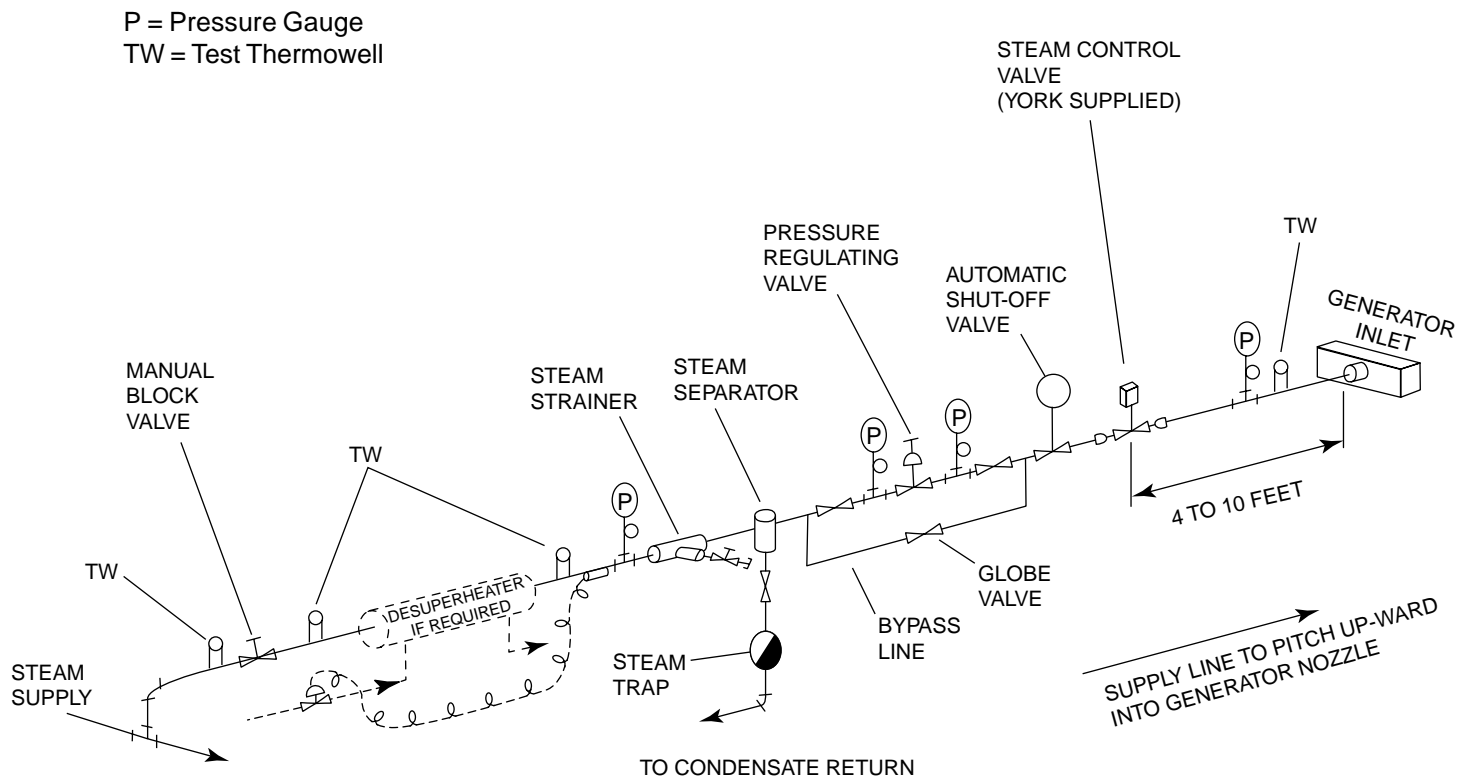

LD04565

FIG. 13 – RECOMMENDED COMPONENT LOCATION FOR INLET STEAM PIPING

Automatic Shut-Off Valve – (Failsafe) This valve must shut off 100% of the steam flow and be bubble tight during a cycling/safety shutdown or a power failure. This valve works in conjunction with the condensate drain solenoid valve.

The YORK supplied steam control valve will remain in whatever position it happened to be in at the time of a power failure. Therefore, a valve that will completely shut-off steam flow to the unit during such a failure is required to keep the unit from crystallization.

Pressure Relief Valve – A 15 PSIG (103 kPa) pressure relief valve should be installed to protect the steam generator vessel. To prevent nuisance blowing of the relief valve, it should be set 2 or 3 PSI (14 to 21 kPa) above the generator operating pressure and within the code requirements. Under no circumstances should the generator steam inlet pressure exceed 15 PSIG (103 kPa). The relief valve should be sized for maximum steam flow and vented in accordance with local codes.

A relief valve is not required if there is a properly sized relief valve provided on the boiler of a low pressure steam system, or in the 15 PSIG (103 kPa) branch circuit of a basically high pressure steam supply.

Steam Control Valve (YORK Supplied) – The steam control valve is supplied by YORK and found among the unit's shipped loose parts. This valve should be connected to the appropriate wiring harness and is used to control the amount of steam that enters the unit. Install the steam control valve between 48 and 120 inches (1.2 m to 3.0 m) from the generator steam inlet flange in order to minimize the pressure drop from the valve exit to the generator inlet.

Steam Inlet Pressure Indicator (if desired) – A pressure gauge can be installed to allow the operator to determine the inlet steam pressure to the unit just before it enters the generator. The inlet steam pressure is indicated by the micropanel, but an additional pressure gauge may be desired.

STEAM CONDENSATE RETURN SYSTEM

Steam condensate return systems should be designed in accordance with good engineering practice for the general purpose of removing condensate from the absorption unit's generator and returning it to the boiler. Either an atmospheric or a vacuum condensate return system may be used with absorption units.

Before a discussion of condensate return systems, it would be beneficial to the reader to have a general understanding of the YORK Single Stage absorption unit operating requirements and characteristics.

The absorption chiller will operate at full load steam pressure in the 9-12 PSIG (62 to 88 kPa) range, down to pressures well into the vacuum region at part load. As the cooling load decreases, the chilled water controller will start closing the steam control valve, hence reducing steam flow and pressure to the generator. At some part load point, say 50% for illustration, the steam pressure will be 0 PSIG, or atmospheric. With further reduction in load, the steam valve will continue to close, resulting in generator steam pressures below atmospheric pressure (providing a vacuum condensate return system is used). If an atmospheric return system is used or if a vacuum breaker is installed at the outlet of the chiller then the generator pressure will not drop below atmospheric. The use of a vacuum breaker is discussed in the component details section which follows.

Three basic types of return systems are possible: **(1)** a completely atmospheric system; **(2)** a system that allows the chiller and steam traps to function at atmospheric pressure, but the remainder of the condensate system/boiler feed to operate in a vacuum; **(3)** a system that operates entirely in a vacuum.

System (1) – For a entirely atmospheric system, a vacuum breaker may be installed at the outlet of the chiller (See Fig. 14). Also in this system both the auxiliary condensate receiver, if needed, and the main condensate receiver must be vented to atmospheric pressure. The auxiliary condensate receiver should be used on completely atmospheric systems when the main condensate receiver is located at some distance from the condensate outlet or above the condensate outlet. This system requires a float controlled pump to move condensate from the auxiliary receiver to the main condensate receiver in addition to the main condensate pump/boiler feed pump.

System (2) – Since the condensate will be at atmospheric pressure until it leaves the auxiliary condensate receiver, a vacuum breaker can still be used if desired (See Fig. 15). The auxiliary condensate receiver must be used in this system. The main condensate tank will no longer be vented to atmospheric pressure. A float control is still used in the auxiliary condensate receiver, however, it controls a valve instead of a pump. The low pressure in the main tank will draw the condensate through when the valve is opened.

For system (2), a condensate cooler must be provided in the line between the steam trap and the auxiliary receiver, as detailed under **condensate cooler** in the component details section of this manual. It must be sized to cool the maximum flow to temperatures 5-10°F (3-6°C) below the saturation point of the vacuum return system.

System (3) – (See Fig. 16) When the low pressure steam for a single stage absorber unit comes at or below atmospheric pressure (i.e. a condensing-type steam turbine exhaust), the entire system can run at a higher efficiency by using a vacuum pump on the condensate return system. At low loads, when the absorption system is operating in the high vacuum region, this vacuum can only be obtained if the condensate return system similarly operates in a vacuum. With a vacuum condensate return system, the steam supply can be at vacuum steam pressure, rather than at a minimum steam pressure of 0 PSIG [as it is limited by systems (1) and (2)]. Discharging at a steam pressure in the vacuum region can improve a condensing-type steam turbine's economy and efficiency.

In system (3) a vacuum breaker cannot be used.

A condensate cooler must be provided in the line between the steam trap and the auxiliary receiver, as detailed under the condensate cooler in the component section of this manual. It must be sized to cool the maximum flow to temperatures 5-10°F (3-6°C) below the saturation point of the vacuum return system.

CONDENSATE RETURN SYSTEM COMPONENTS

Steam Condensate Drain Solenoid Valve – This valve is supplied by YORK. It is used to insure zero steam flow through the generator when the unit is shut down. This valve should be installed in a horizontal run of pipe within 24 inches (0.6 m) of the generator condensate outlet box. This valve works in conjunction with the Automatic Shut-Off Valve at the steam inlet.

Vacuum Breaker (if desired) – A vacuum breaker will often not be necessary, but one can prevent condensate build up in the generator bundle of the chiller at part loads.

If an atmospheric return system is used the generator will not operate in the vacuum region, but will operate at atmospheric pressure even at low load conditions. Throttling of the steam valve at low load results in steam condensate to back-up into the generator tubes. As the load increases, the steam valve will open further to raise the steam pressure and push the backed-up condensate out of the generator. The accumulation of condensate in the generator at reduced loads and subsequent drainage will have no adverse effect on absorption unit efficiency. However, due to the cyclical drainage of condensate from the unit, the main system condensate receiver must be sized with sufficient additional capacity to accommodate this fluctuation of condensate quantities. The capacity of the main system condensate receiver is assumed to be equal to the absorption unit generator tube volume as a maximum - See Table 2 for IsoFlow™ Unit Shell and Tube Volumes.

To help avoid fluctuation in condensate return or water hammer in the generator, a vacuum breaker swing check valve can be added as shown in Fig. 17. A 3/8 inch size is sufficient to prevent condensate build-up and water hammer. For safety, a pipe should be installed from the check valve to a location close to the floor or other safe place. The use of the check valve to permit air entrance into the generator tubes has the disadvantage that this air must later be purged through the thermostatic element of the float trap and tends to entrain air in the condensate return.

Strainer(s) – A fine mesh strainer with a blow-off valve should be provided ahead of the steam trap(s) to protect it from damage.

Float and Thermostatic Steam Trap(s) – This float and trap serve the purpose of passing condensate, but preventing the loss of steam. The float and thermostatic steam trap should be applied in accordance with the manufacturer's recommendations. The trap should be located as close to the generator condensate outlet as possible in the horizontal plane. In the vertical plane, the trap should be located below the generator condensate outlet, a minimum of 12 inches (0.3m).

Preferably, the maximum possible elevation between the generator outlet and the trap should be used.

The condensate outlet line should be sized in accordance with good engineering practice for condensate at the flash point and should be kept as short and simple as possible. Stop valves should be provided ahead of the strainer and after the trap for maintenance purposes. A full size bypass line provided with a globe valve for manual operation during maintenance should be supplied. Also, a full trap outlet line size connection and valve should be provided for blow-off and test purposes.

The steam trap should be selected for about 1.5 times the design full steam flow rate, at the design operating pressure differential. The operating full load pressure differential: $PD = SP - P_1 - P_2 - P_3$

Where:

PD = Trap pressure drop, PSI

SP = Steam pressure, PSIG, at generator flange normally 3 PSI less than the design pressure to the control valve.

P_1 = Condensate line pressure drop losses, PSI

P_2 = Check valve pressure drop loss, PSI

P_3 = Condensate cooler pressure drop loss, PSI

Select float capacity from manufacturer's ratings per above recommendations.

The line from the steam trap to the condensate receiver will contain some flash vapor flowing with the condensate. This line should always be as short as possible, preferably not more than 30 feet (9m) in equivalent length. As a general rule, it should be sized according to the number of traps used and one or more sizes larger in the case of longer piping runs.

Check Valve – A check valve should be provided in the trap outlet line to prevent any possible air or condensate leakage back to the generator under reduced load operating conditions.

Condensate Cooler – The use of a condensate cooler between the trap and the condensate receiver to cool the condensate below its flash point is required for vacuum return systems and may be desirable, though not required, for atmospheric return systems.

The variations in condensate flow must be recognized and the cooler selected to cool the maximum flow of condensate 5 - 10°F (3 - 6°C) below the saturation temperature of the lowest pressure in the system (atmospheric pressure for an atmospheric return or the lowest pressure in a vacuum return system). Sufficient

coolant must be provided to cool the maximum condensate flow to the desired temperature. Coolers may be air or evaporatively cooled, providing they can produce the desired leaving condensate temperature. Coolant flow could be manually set for maximum load and allowed to operate continuously at that level with no operating difficulties, but the poor economics of such an arrangement make automatic control preferable.

Auxiliary Condensate Receiver – An auxiliary condensate receiver must be used if the main condensate receiver is located a great distance from the chiller or above the chiller. An auxiliary condensate pump is used to send condensate from the auxiliary receiver to the main condensate receiver.

The auxiliary condensate receiver should be located at floor level as close to the absorption unit as possible. A check valve in the auxiliary condensate pump discharge line is recommended where condensate backflow may occur.

Auxiliary condensate receivers with condensate pumps are available as a package. They include a float or other control to cycle the pump to suit the condensate flow. Manufacturers' recommendations concerning selection and application of these packages should be followed.

TABLE 2 – SHELL AND TUBE VOLUMES

| CHILLER SHELL AND TUBE VOLUMES | | | | | | | | | | | | |
|--------------------------------|------------|--------|------------|--------|-----------|--------|------------|--------|-----------|--------|-----------|--------|
| Unit Model | SHELL SIDE | | | | TUBE SIDE | | | | | | | |
| | Gen / Cond | | Abs / Evap | | Absorber | | Evaporator | | Generator | | Condenser | |
| | Gallons | Liters | Gallons | Liters | Gallons | Liters | Gallons | Liters | Gallons | Liters | Gallons | Liters |
| 1A1 | 175 | 662 | 543 | 2055 | 45 | 170 | 32 | 121 | 14 | 53 | 16 | 61 |
| 1A2 | 211 | 799 | 653 | 2472 | 52 | 197 | 36 | 136 | 16 | 61 | 18 | 68 |
| 2A3 | 249 | 943 | 764 | 2892 | 58 | 220 | 40 | 151 | 17 | 64 | 25 | 95 |
| 2A4 | 277 | 1049 | 875 | 3312 | 64 | 242 | 45 | 170 | 19 | 72 | 28 | 106 |
| 2B1 | 361 | 1366 | 1006 | 3808 | 81 | 307 | 55 | 208 | 23 | 87 | 28 | 106 |
| 3B2 | 405 | 1533 | 1152 | 4361 | 90 | 341 | 61 | 231 | 25 | 95 | 40 | 151 |
| 3B3 | 456 | 1726 | 1298 | 4913 | 99 | 375 | 67 | 254 | 28 | 106 | 44 | 167 |
| 4B4 | 508 | 1923 | 1444 | 5466 | 108 | 409 | 73 | 276 | 30 | 114 | 48 | 182 |
| 4C1 | 587 | 2222 | 1516 | 5739 | 130 | 492 | 88 | 333 | 37 | 140 | 49 | 185 |
| 5C2 | 646 | 2445 | 1701 | 6439 | 143 | 541 | 96 | 363 | 41 | 155 | 68 | 257 |
| 5C3 | 719 | 2722 | 1899 | 7188 | 156 | 591 | 105 | 397 | 44 | 167 | 75 | 284 |
| 6C4 | 810 | 3066 | 2136 | 8085 | 171 | 647 | 115 | 435 | 49 | 185 | 82 | 310 |
| 7D1 | 904 | 3422 | 2690 | 10182 | 193 | 731 | 134 | 507 | 56 | 212 | 91 | 344 |
| 7D2 | 1004 | 3800 | 2992 | 11326 | 210 | 795 | 146 | 553 | 61 | 231 | 100 | 379 |
| 8D3 | 1130 | 4277 | 3371 | 12760 | 232 | 878 | 160 | 606 | 66 | 250 | 110 | 416 |
| 8E1 | 1264 | 4785 | 3756 | 14218 | 278 | 1052 | 192 | 727 | 82 | 310 | 141 | 534 |
| 9E2 | 1423 | 5386 | 4230 | 16012 | 306 | 1158 | 211 | 799 | 90 | 341 | 156 | 591 |
| 10E3 | 1582 | 5988 | 4705 | 17810 | 334 | 1264 | 230 | 871 | 97 | 367 | 171 | 647 |
| 12F1 | 1911 | 7234 | 5137 | 19445 | 395 | 1495 | 269 | 1018 | 124 | 469 | 204 | 772 |
| 13F2 | 2125 | 8044 | 5730 | 21690 | 431 | 1631 | 293 | 1109 | 135 | 511 | 223 | 844 |
| 14F3 | 2340 | 8858 | 6311 | 23889 | 467 | 1768 | 315 | 1192 | 145 | 549 | 242 | 916 |

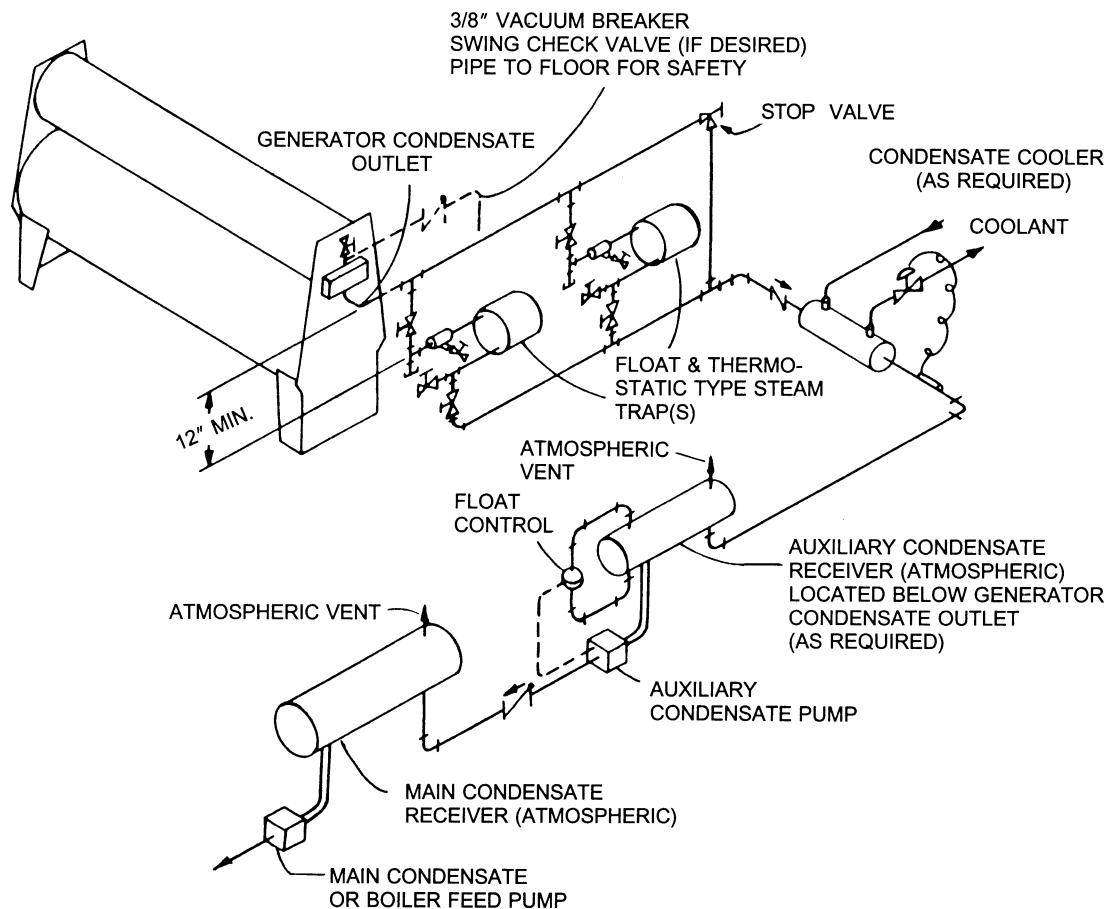

LD00684 (R)

FIG. 14 – SYSTEM 1 - ATMOSPHERIC CONDENSATE RETURN SYSTEM

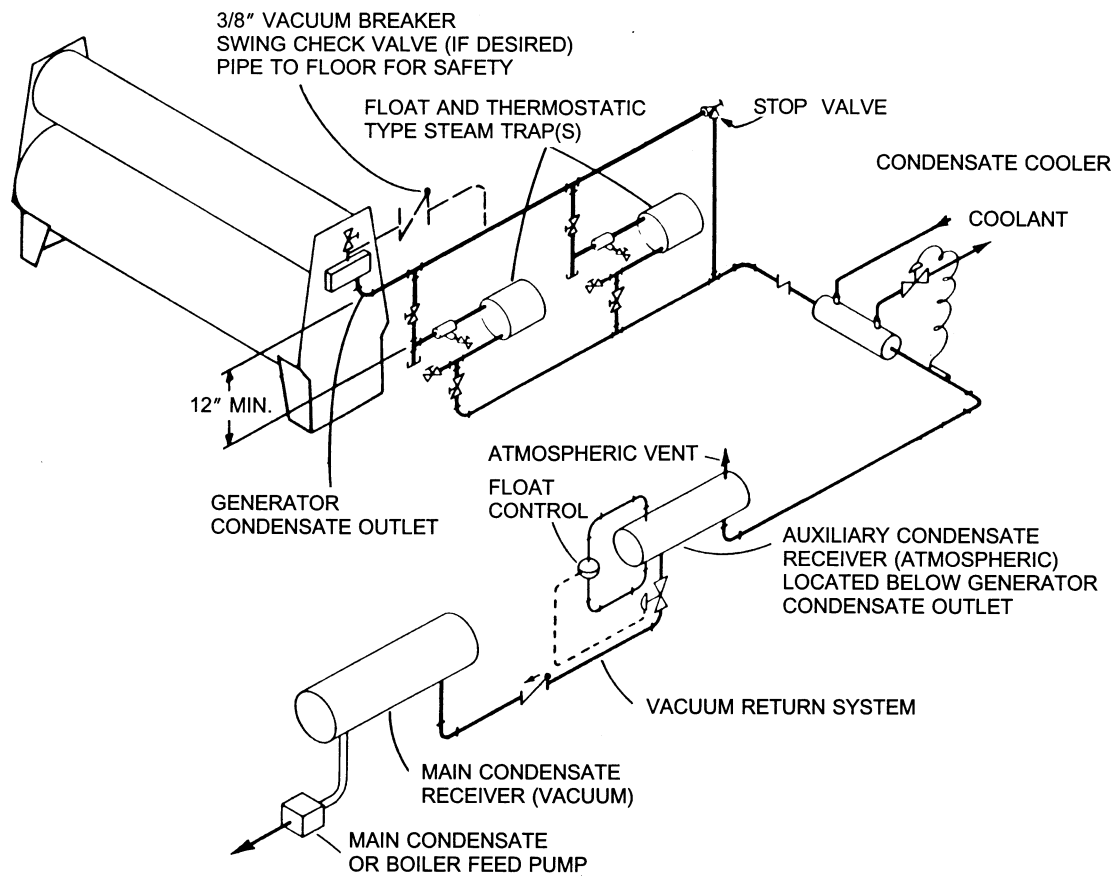

LD00685 (R)

FIG. 15 – SYSTEM 2 - VACUUM CONDENSATE RETURN SYSTEM

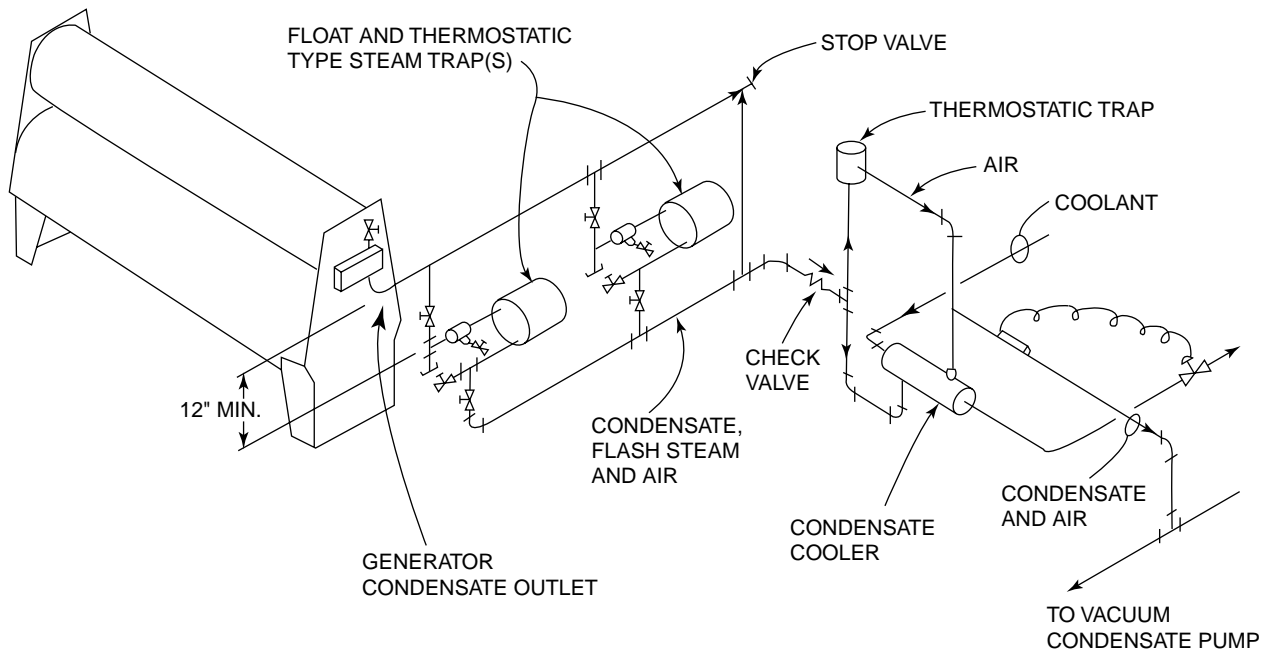

LD04748

FIG. 16 – SYSTEM 3 - VACUUM CONDENSATE RETURN SYSTEM WHEN INLET STEAM AND OUTLET CONDENSATE ARE UNDER VACUUM

HOT WATER PIPING

The design level “B” IsoFlow™ absorption chiller is designed for a maximum hot water entering temperature of up to 266°F (130°C) and a generator working hot water pressure up to 150 PSIG (1034 kPa). A factory special option can be purchased to enable the hot water working pressure up to 300 PSIG (2068 kPa).

All field hot water supply and return piping should be installed in accordance with any local, state or federal codes that may apply. Piping must be adequately supported and braced independent of the chiller. The chiller water boxes and nozzles are not designed to handle any load bearing stress or strain. The support system must account for the expansion and contraction of the hot water being supplied to and returned from the unit. All hot water piping should be designed in accordance with good engineering practice.

For control on hot water IsoFlow™ absorption chillers, YORK utilizes a 3-way control valve. This type of control valve maintains a relatively constant flow rate (GPM) to the generator and will vary the temperature. This type of control is preferred and supports YORK’s software control programming. A 2-way hot water control valve is not recommended because this type of valve will vary the flow rate (GPM) and keep the hot water temperature constant.

One hot water 3-way valve with an electronic actuator is furnished for field installation with each IsoFlow™ Unit sold. This valve is included along with the unit’s shipped loose parts.

The 3-way valve must be installed to facilitate a diverting service. A valve in diverting service will have one inlet port and two outlet ports. It will shut off flow to one outlet port as it simultaneously opens the flow to another

outlet port. Therefore, keeping the flow constant while the temperature changes. This can be done in two different ways depending on the valve manufacturer. See below Fig. 17 for valves manufactured by Honeywell.

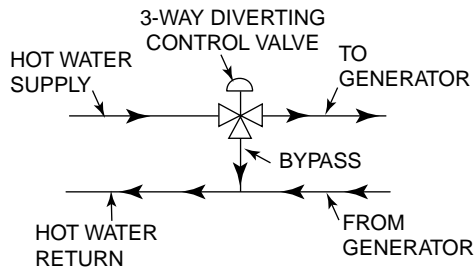

FOR HONEYWELL VALVE LD00944

FIG. 17 – DIVERTING SERVICE FOR HONEYWELL VALVE

For Honeywell valves, the hot water supply enters the valve at the “common” connection. The hot water outlet to the generator is sometimes marked “A” or is unmarked. The bypass connection is sometimes marked “B” or it may also be unmarked.

See Fig. 18 for installing valves manufactured by Fisher.

For Fisher valves the hot water supply enters the valve at the marked “inlet” connection and exits the valve to go to the generator at the marked “unit” connection. The bypass connection is sometimes marked “bypass”.

INLET AND OUTLET HOT WATER PIPING

Fig. 19 is a sample of a hot water piping arrangement for a YORK IsoFlow™ absorption chiller depicting a Fisher 3-way hot water control valve.

The following is a description of each component on the hot water supply/return line to the unit.

Manual Block Valves – These valves are installed, one on the supply line and one on the return line, to manually shut off hot water to the unit, thus allowing ease of serviceability if required.

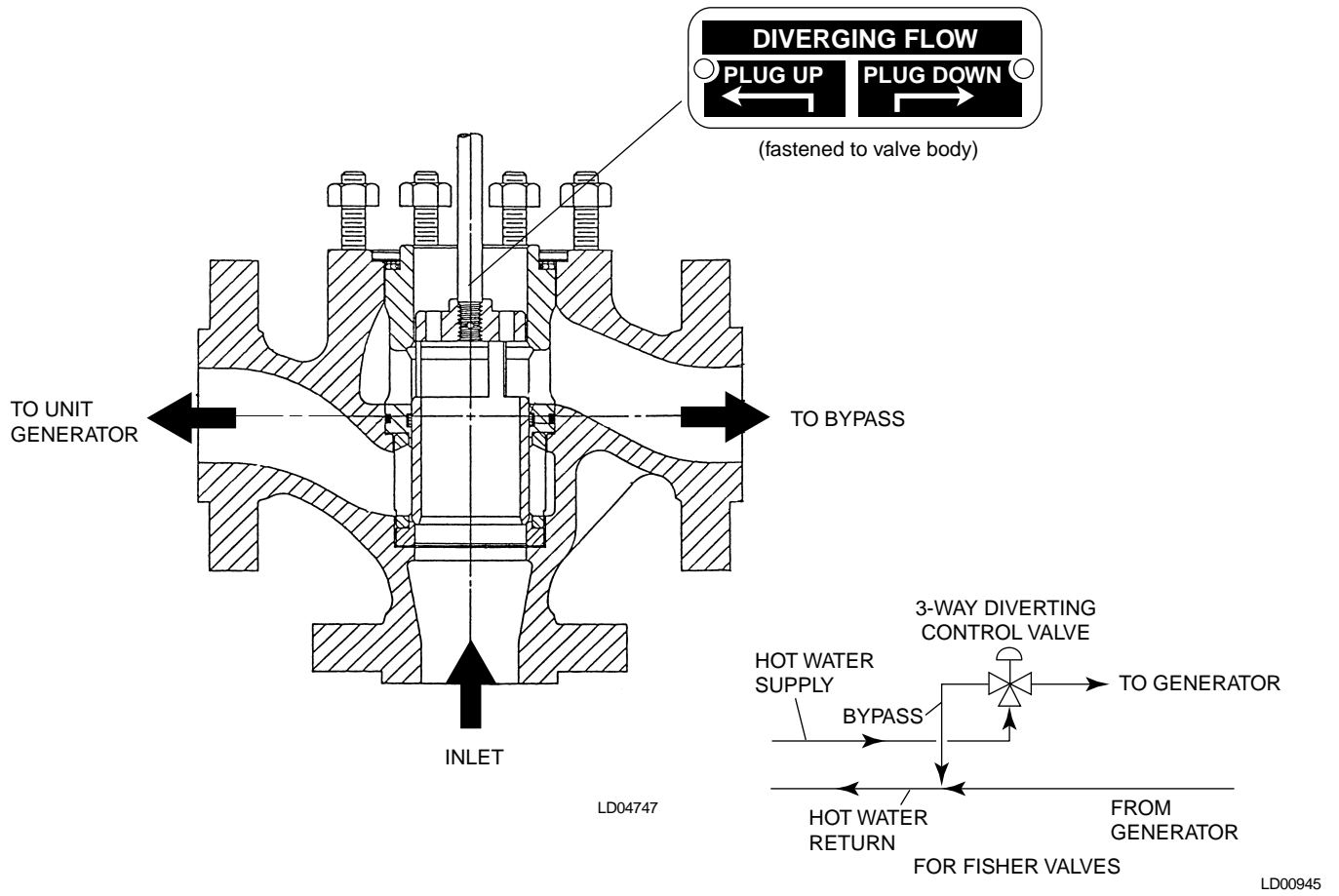

LD04747

LD00945

FIG. 18 – DIVERTING SERVICE FOR FISHER VALVES / DETAIL OF FISHER VALVE

Automatic Shut-Off Valve – (failsafe) This valve must shut off 100% of the hot water supply flow and be bubble tight during a cycling/safety shutdown or a power failure.

The YORK supplied hot water control valve will remain in whatever position it happened to be in at the time of a power failure. Therefore, a valve that will completely shut-off hot water flow to the unit during such a failure is required to keep the unit from crystallization.

Hot Water Control Valve (YORK supplied) – The hot water control valve is supplied by YORK and can be found in a separate box among the unit’s shipped loose parts. This valve must be connected to the appropriate wiring harness and will be used in a diverting service to control the temperature of hot water entering the unit. See Fig. 17 or 18 for a schematic on how to install the hot water control valve in a diverting service according to the valve’s manufacturer.

If hot water supply is not shut off on unit shutdown, water will flow through the bypass. Special precautions

should be taken to prevent heating of the generator by thermal circulation. Either locate the three-way hot water control valve and its bypass line two feet or more above the generator connection, or install a check valve with a 3/4" (19.1 mm) bypass around the check valve.

Check Valve – On hot water unit shutdown, the water left in the generator will start to contract as it cools off. This may form a vacuum inside the generator tube bundle. This can be prevented by installing a check valve in the return hot water piping with a 3/4" (19.1 mm) bypass around the check valve. It should be installed between the generator outlet nozzle and the hot water bypass. See Fig. 19.

Hot water inlet & outlet pressure indicator – A pressure gauge should be installed on the inlet and outlet lines of the generator. This will allow the operator to determine the inlet and outlet hot water pressure and the pressure drop through the generator tube bundle.

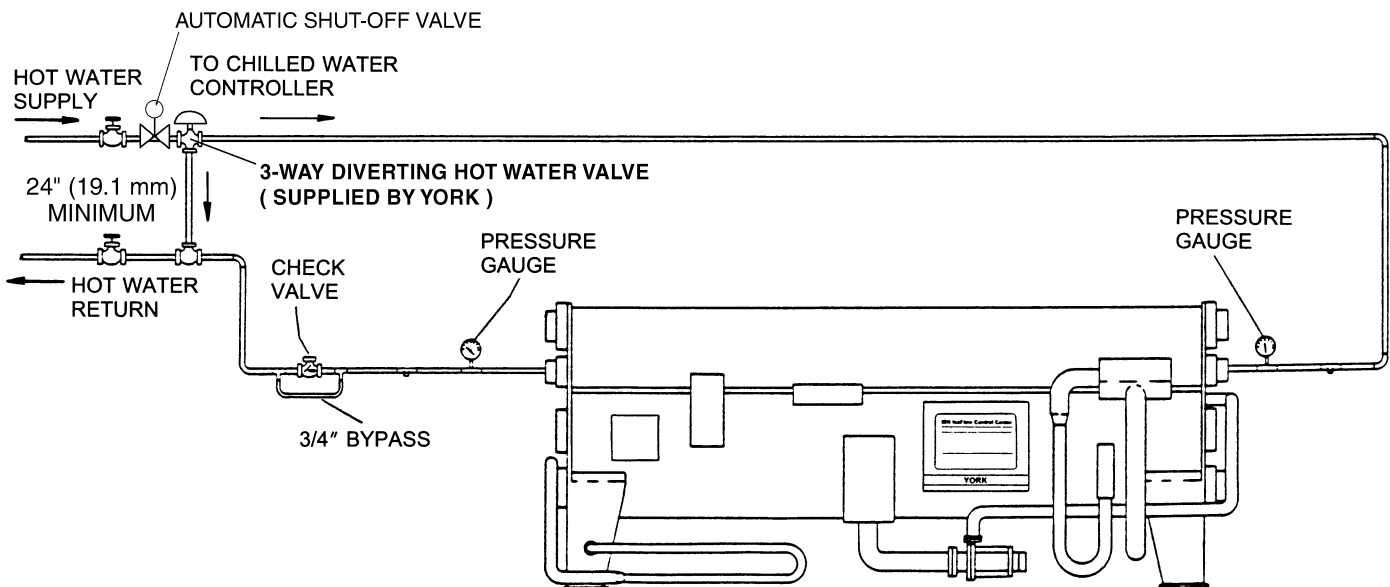

LD00690B

FIG. 19 – TYPICAL HOT WATER PIPING SYSTEM (SINGLE PASS GENERATOR)

ELECTRICAL CONNECTIONS

Included with the unit's literature packet is an elementary and connection wiring diagram. Refer to this diagram for electrical connections. If this literature is not available, refer to York Forms 155.16-PA2 and 155.16-W4, which can be obtained through the your local York Service office.

Located in the power panel in all IsoFlow™ absorption chiller models is a 100 amp, non-fused, service disconnect switch. Throwing this switch will cut power off to the unit controls and devices. In addition to this switch, a customer supplied separate wall mounted, fused unit disconnect switch is necessary to totally shut off power to the unit. See table 3 for fuse sizing and amp requirements for your IsoFlow™ absorption unit.

All wiring must be in accordance with the National Electrical Code (NEC) and any other applicable local codes and specifications. The unit must be grounded in accordance with NEC, Table 250-95. Use only copper conductors for all unit wiring. The power panel is furnished with ground lugs suitable for wire sizes between #14 to 1/0 AWG.

Connect the proper three-phase current supply through the customer supplied fused disconnect switch to L1, L2 and L3 in the unit mounted power panel. This is the only power connection needed to the chiller. The micro panel control power (115V, 50/60 Hz, 10 amps) is supplied through a factory mounted control power transformer (CPT) located inside the power panel. If multiple conduits are used for the incoming three phase power, they should contain an equal number of wires from each phase in each conduit to prevent overheating. Use copper conductors only; do not use aluminum conductors. Flexible conduit for final connection to the power panel should be used in the extreme case of unit vibration. See Fig. 20 for system water pump and flow

switch details. See Fig. 21 for field wiring all models of IsoFlow™ absorption units.

Use #14 AWG copper wire for one way distance of less than 175 feet. Use #12 AWG copper wire for one way distance of more than 175 feet and no more than 300 feet.



Improperly installed or sized capacitors may result in equipment malfunction or damage.

Power factor correction capacitors, when used, must be sized to meet the NEC and verified through the local York International office.

Each 115 VAC field-connected inductive load, i.e., relay coil, motor starter coil, etc. shall have a transient suppressor wired (by others) in parallel with its coil, physically located at the coil. Spare transient suppressors are factory supplied in a bag located in the unit's micro panel.

Fig. 20 shows automatic control of the chilled and condenser water pumps by the micro panel control center. Chilled and condenser water pump motor starter holding coils to be furnished for 115VAC, 50/60 Hz. The total power requirements for the water pump starters (7M, 8M) must be a maximum of 1.0 amp inductive at 115VAC. If power requirements exceed this value, furnish coil for the line voltage, and control relays with 115VAC coil.

Two chilled water pump operating modes are available via the low leaving chilled water temperature (LWT) pump programming jumper J54 on the micro board. With J54 installed, the chilled water pump operates during start sequence, during unit operation, and LWT shutdowns; with J54 removed, the chilled water pump operates as above plus it operates during MULTI-UNIT and REMOTE/LOCAL cycling shutdowns.

TABLE 3 – ELECTRICAL RATINGS

| Chiller Model | Voltage (Volts-Ph-Hz) | Solution Pump | | Refrigerant Pump | | Purge Pump | | Panel (KVA) | Total Amps | Minimum Circuit Ampacity | Max-Dual Elem. Fuse (Customer supplied) |
|---------------|-----------------------|---------------|------|------------------|------|------------|------|-------------|------------|--------------------------|---|
| | | FLA | LRA | FLA | LRA | FLA | LRA | | | | |
| 1A1 | 200/208-3-60 | 12.5 | 51.0 | 12.5 | 51.0 | 2.3 | 12.2 | 5.0 | 32.2 | 35.2 | 45 |
| | 230-3-60 | 12.0 | 55.0 | 12.0 | 55.0 | 2.2 | 11.0 | 4.3 | 30.4 | 33.5 | 45 |
| | 380-3-50 | 6.5 | 23.0 | 6.5 | 23.0 | 1.2 | 6.0 | 2.6 | 16.7 | 18.3 | 20 |
| | 460-3-60 | 6.0 | 27.5 | 6.0 | 27.5 | 1.1 | 5.5 | 2.2 | 15.2 | 16.8 | 20 |
| | 575-3-60 | 4.9 | 24.0 | 4.9 | 24.0 | 0.9 | 8.0 | 1.7 | 12.4 | 13.7 | 15 |
| 1A2 | 200/208-3-60 | 12.5 | 51.0 | 12.5 | 51.0 | 2.3 | 12.2 | 5.0 | 32.2 | 35.2 | 45 |
| | 230-3-60 | 12.0 | 55.0 | 12.0 | 55.0 | 2.2 | 11.0 | 4.3 | 30.4 | 33.5 | 45 |
| | 380-3-50 | 6.5 | 23.0 | 6.5 | 23.0 | 1.2 | 6.0 | 2.6 | 16.7 | 18.3 | 20 |
| | 460-3-60 | 6.0 | 27.5 | 6.0 | 27.5 | 1.1 | 5.5 | 2.2 | 15.2 | 16.8 | 20 |
| | 575-3-60 | 4.9 | 24.0 | 4.9 | 24.0 | 0.9 | 8.0 | 1.7 | 12.4 | 13.7 | 15 |
| 2A3 | 200/208-3-60 | 12.5 | 51.0 | 12.5 | 51.0 | 2.3 | 12.2 | 5.0 | 32.2 | 35.2 | 45 |
| | 230-3-60 | 12.0 | 55.0 | 12.0 | 55.0 | 2.2 | 11.0 | 4.3 | 30.4 | 33.5 | 45 |
| | 380-3-50 | 6.5 | 23.0 | 6.5 | 23.0 | 1.2 | 6.0 | 2.6 | 16.7 | 18.3 | 20 |
| | 460-3-60 | 6.0 | 27.5 | 6.0 | 27.5 | 1.1 | 5.5 | 2.2 | 15.2 | 16.8 | 20 |
| | 575-3-60 | 4.9 | 24.0 | 4.9 | 24.0 | 0.9 | 8.0 | 1.7 | 12.4 | 13.7 | 15 |
| 2A4 | 200/208-3-60 | 12.5 | 51.0 | 12.5 | 51.0 | 2.3 | 12.2 | 5.0 | 32.2 | 35.2 | 45 |
| | 230-3-60 | 12.0 | 55.0 | 12.0 | 55.0 | 2.2 | 11.0 | 4.3 | 30.4 | 33.5 | 45 |
| | 380-3-50 | 6.5 | 23.0 | 6.5 | 23.0 | 1.2 | 6.0 | 2.6 | 16.7 | 18.3 | 20 |
| | 460-3-60 | 6.0 | 27.5 | 6.0 | 27.5 | 1.1 | 5.5 | 2.2 | 15.2 | 16.8 | 20 |
| | 575-3-60 | 4.9 | 24.0 | 4.9 | 24.0 | 0.9 | 8.0 | 1.7 | 12.4 | 13.7 | 15 |
| 2B1 | 200/208-3-60 | 12.5 | 51.0 | 12.5 | 51.0 | 2.3 | 12.2 | 5.0 | 32.2 | 35.2 | 45 |
| | 230-3-60 | 12.0 | 55.0 | 12.0 | 55.0 | 2.2 | 11.0 | 4.3 | 30.4 | 33.5 | 45 |
| | 380-3-50 | 6.5 | 23.0 | 6.5 | 23.0 | 1.2 | 6.0 | 2.6 | 16.7 | 18.3 | 20 |
| | 460-3-60 | 6.0 | 27.5 | 6.0 | 27.5 | 1.1 | 5.5 | 2.2 | 15.2 | 16.8 | 20 |
| | 575-3-60 | 4.9 | 24.0 | 4.9 | 24.0 | 0.9 | 8.0 | 1.7 | 12.4 | 13.7 | 15 |
| 3B2 | 200/208-3-60 | 20.0 | 78.0 | 12.5 | 51.0 | 2.3 | 12.2 | 5.0 | 39.7 | 44.6 | 60 |
| | 230-3-60 | 19.0 | 80.0 | 12.0 | 55.0 | 2.2 | 11.0 | 4.3 | 37.4 | 42.3 | 60 |
| | 380-3-50 | 6.5 | 23.0 | 6.5 | 23.0 | 1.2 | 6.0 | 2.6 | 17.8 | 19.4 | 20 |
| | 460-3-60 | 9.5 | 40.0 | 6.0 | 27.5 | 1.1 | 5.5 | 2.2 | 18.7 | 21.2 | 30 |
| | 575-3-60 | 7.7 | 33.0 | 4.9 | 24.0 | 0.9 | 8.0 | 1.7 | 15.3 | 17.3 | 20 |
| 3B3 | 200/208-3-60 | 20.0 | 78.0 | 12.5 | 51.0 | 2.3 | 12.2 | 5.0 | 38.6 | 43.5 | 60 |
| | 230-3-60 | 19.0 | 80.0 | 12.0 | 55.0 | 2.2 | 11.0 | 4.3 | 37.3 | 42.2 | 60 |
| | 380-3-50 | 9.5 | 38.0 | 6.5 | 23.0 | 1.2 | 6.0 | 2.6 | 20.8 | 23.2 | 30 |
| | 460-3-60 | 9.5 | 40.0 | 6.0 | 27.5 | 1.1 | 5.5 | 2.2 | 18.7 | 21.2 | 30 |
| | 575-3-60 | 7.7 | 33.0 | 4.9 | 24.0 | 0.9 | 8.0 | 1.7 | 15.3 | 17.3 | 20 |
| 4B4 | 200/208-3-60 | 20.0 | 78.0 | 12.5 | 51.0 | 2.3 | 12.2 | 5.0 | 38.6 | 43.5 | 60 |
| | 230-3-60 | 19.0 | 80.0 | 12.0 | 55.0 | 2.2 | 11.0 | 4.3 | 37.3 | 42.2 | 60 |
| | 380-3-50 | 9.5 | 38.0 | 6.5 | 23.0 | 1.2 | 6.0 | 2.6 | 20.8 | 23.2 | 30 |
| | 460-3-60 | 9.5 | 40.0 | 6.0 | 27.5 | 1.1 | 5.5 | 2.2 | 18.7 | 21.2 | 30 |
| | 575-3-60 | 7.7 | 33.0 | 4.9 | 24.0 | 0.9 | 8.0 | 1.7 | 15.3 | 17.3 | 20 |
| 4C1 | 200/208-3-60 | 20.0 | 78.0 | 12.5 | 51.0 | 2.3 | 12.2 | 5.0 | 38.6 | 43.5 | 60 |
| | 230-3-60 | 19.0 | 80.0 | 12.0 | 55.0 | 2.2 | 11.0 | 4.3 | 37.3 | 42.2 | 60 |
| | 380-3-50 | 9.5 | 38.0 | 6.5 | 23.0 | 1.2 | 6.0 | 2.6 | 20.8 | 23.2 | 30 |
| | 460-3-60 | 9.5 | 40.0 | 6.0 | 27.5 | 1.1 | 5.5 | 2.2 | 18.7 | 21.2 | 30 |
| | 575-3-60 | 7.7 | 33.0 | 4.9 | 24.0 | 0.9 | 8.0 | 1.7 | 15.3 | 17.3 | 20 |
| 5C2 | 200/208-3-60 | 20.0 | 78.0 | 12.5 | 51.0 | 2.3 | 12.2 | 5.0 | 39.7 | 43.5 | 60 |
| | 230-3-60 | 19.0 | 80.0 | 12.0 | 55.0 | 2.2 | 11.0 | 4.3 | 37.4 | 42.2 | 60 |
| | 380-3-50 | 9.5 | 38.0 | 6.5 | 23.0 | 1.2 | 6.0 | 2.6 | 19.7 | 23.2 | 30 |
| | 460-3-60 | 9.5 | 40.0 | 6.0 | 27.5 | 1.1 | 5.5 | 2.2 | 18.7 | 21.2 | 30 |
| | 575-3-60 | 7.7 | 33.0 | 4.9 | 24.0 | 0.9 | 8.0 | 1.7 | 15.2 | 17.3 | 20 |
| 5C3 | 200/208-3-60 | 20.0 | 78.0 | 12.5 | 51.0 | 2.3 | 12.2 | 5.0 | 39.7 | 43.5 | 60 |
| | 230-3-60 | 19.0 | 80.0 | 12.0 | 55.0 | 2.2 | 11.0 | 4.3 | 37.4 | 42.2 | 60 |
| | 380-3-50 | 14.0 | 38.0 | 6.5 | 23.0 | 1.2 | 6.0 | 2.6 | 24.2 | 28.8 | 40 |
| | 460-3-60 | 9.5 | 40.0 | 6.0 | 27.5 | 1.1 | 5.5 | 2.2 | 18.7 | 21.2 | 30 |
| | 575-3-60 | 7.7 | 33.0 | 4.9 | 24.0 | 0.9 | 8.0 | 1.7 | 15.2 | 17.3 | 20 |

TABLE 3 – ELECTRICAL RATINGS (Cont'd)

| Chiller Model | Voltage (Volts-Ph-Hz) | Solution Pump | | Refrigerant Pump | | Purge Pump | | Panel (KVA) | Total Amps | Minimum Circuit Ampacity | Max-Dual Elem. Fuse (Customer supplied) |
|---------------|-----------------------|---------------|-------|------------------|-------|------------|------|-------------|------------|--------------------------|---|
| | | FLA | LRA | FLA | LRA | FLA | LRA | | | | |
| 6C4 | 200/208-3-60 | 20.0 | 78.0 | 12.5 | 51.0 | 2.3 | 12.2 | 5.0 | 39.7 | 43.5 | 60 |
| | 230-3-60 | 19.0 | 80.0 | 12.0 | 55.0 | 2.2 | 11.0 | 4.3 | 37.4 | 42.2 | 60 |
| | 380-3-50 | 14.0 | 65.0 | 6.5 | 23.0 | 1.2 | 6.0 | 2.6 | 24.2 | 28.8 | 40 |
| | 460-3-60 | 9.5 | 40.0 | 6.0 | 27.5 | 1.1 | 5.5 | 2.2 | 18.7 | 21.2 | 30 |
| | 575-3-60 | 7.7 | 33.0 | 4.9 | 24.0 | 0.9 | 8.0 | 1.7 | 15.2 | 17.3 | 20 |
| 7D1 | 200/208-3-60 | 20.0 | 78.0 | 12.5 | 51.0 | 2.3 | 12.2 | 5.0 | 39.7 | 60.9 | 90 |
| | 230-3-60 | 19.0 | 80.0 | 12.0 | 55.0 | 2.2 | 11.0 | 4.3 | 37.4 | 56.0 | 80 |
| | 380-3-50 | 14.0 | 65.0 | 6.5 | 23.0 | 1.2 | 6.0 | 2.6 | 24.2 | 27.7 | 40 |
| | 460-3-60 | 9.5 | 40.0 | 6.0 | 27.5 | 1.1 | 5.5 | 2.2 | 18.7 | 28.1 | 40 |
| | 575-3-60 | 7.7 | 33.0 | 4.9 | 24.0 | 0.9 | 8.0 | 1.7 | 15.2 | 22.6 | 30 |
| 7D2 | 200/208-3-60 | 33.0 | 107.0 | 12.5 | 51.0 | 2.3 | 12.2 | 5.0 | 52.7 | 60.9 | 90 |
| | 230-3-60 | 30.0 | 118.0 | 12.0 | 55.0 | 2.2 | 11.0 | 4.3 | 48.4 | 56.0 | 80 |
| | 380-3-50 | 14.0 | 65.0 | 6.5 | 23.0 | 1.2 | 6.0 | 2.6 | 24.2 | 27.7 | 40 |
| | 460-3-60 | 15.0 | 59.0 | 6.0 | 27.5 | 1.1 | 5.5 | 2.2 | 24.2 | 28.1 | 40 |
| | 575-3-60 | 12.0 | 47.0 | 4.9 | 24.0 | 0.9 | 8.0 | 1.7 | 19.5 | 22.6 | 30 |
| 8D3 | 200/208-3-60 | 33.0 | 107.0 | 12.5 | 51.0 | 2.3 | 12.2 | 5.0 | 52.7 | 60.9 | 90 |
| | 230-3-60 | 30.0 | 118.0 | 12.0 | 55.0 | 2.2 | 11.0 | 4.3 | 48.4 | 56.0 | 80 |
| | 380-3-50 | 14.0 | 65.0 | 6.5 | 23.0 | 1.2 | 6.0 | 2.6 | 24.2 | 30.7 | 40 |
| | 460-3-60 | 15.0 | 59.0 | 6.0 | 27.5 | 1.1 | 5.5 | 2.2 | 24.2 | 28.1 | 40 |
| | 575-3-60 | 12.0 | 47.0 | 4.9 | 24.0 | 0.9 | 8.0 | 1.7 | 19.5 | 22.7 | 30 |
| 8E1 | 200/208-3-60 | 33.0 | 107.0 | 12.5 | 51.0 | 2.3 | 12.2 | 5.0 | 52.7 | 79.0 | 110 |
| | 230-3-60 | 30.0 | 118.0 | 12.0 | 55.0 | 2.2 | 11.0 | 4.3 | 48.4 | 71.5 | 100 |
| | 380-3-50 | 14.0 | 65.0 | 9.5 | 38.0 | 1.2 | 6.0 | 2.6 | 27.2 | 35.2 | 45 |
| | 460-3-60 | 15.0 | 59.0 | 6.0 | 27.5 | 1.1 | 5.5 | 2.2 | 24.2 | 35.8 | 50 |
| | 575-3-60 | 12.0 | 47.0 | 4.9 | 24.0 | 0.9 | 8.0 | 1.7 | 19.5 | 29.3 | 40 |
| 9E2 | 200/208-3-60 | 40.7 | 118.0 | 21.0 | 78.0 | 2.3 | 12.2 | 5.0 | 68.9 | 91.0 | 125 |
| | 230-3-60 | 36.8 | 130.0 | 19.0 | 80.0 | 2.2 | 11.0 | 4.3 | 62.2 | 82.5 | 110 |
| | 380-3-50 | 14.0 | 65.0 | 14.0 | 65.0 | 1.2 | 6.0 | 2.6 | 31.7 | 35.2 | 45 |
| | 460-3-60 | 18.4 | 65.0 | 9.5 | 40.0 | 1.1 | 5.5 | 2.2 | 31.1 | 41.3 | 50 |
| | 575-3-60 | 15.0 | 52.0 | 7.7 | 33.0 | 0.9 | 8.0 | 1.7 | 25.3 | 33.6 | 45 |
| 10E3 | 200/208-3-60 | 40.7 | 118.0 | 33.0 | 107.0 | 2.3 | 12.2 | 5.0 | 80.9 | 81.4 | 110 |
| | 230-3-60 | 36.8 | 130.0 | 30.0 | 118.0 | 2.2 | 11.0 | 4.3 | 73.2 | 74.0 | 100 |
| | 380-3-50 | 14.0 | 65.0 | 14.0 | 65.0 | 1.2 | 6.0 | 2.6 | 31.7 | 35.2 | 45 |
| | 460-3-60 | 18.4 | 65.0 | 15.0 | 59.0 | 1.1 | 5.5 | 2.2 | 36.6 | 37.1 | 50 |
| | 575-3-60 | 15.0 | 52.0 | 12.0 | 47.0 | 0.9 | 8.0 | 1.7 | 29.6 | 29.8 | 40 |
| 12F1 | 200/208-3-60 | 33.0 | 107.0 | 33.0 | 107.0 | 2.3 | 12.2 | 5.0 | 73.2 | 81.4 | 110 |
| | 230-3-60 | 30.0 | 118.0 | 30.0 | 118.0 | 2.2 | 11.0 | 4.3 | 66.4 | 74.0 | 100 |
| | 380-3-50 | 14.0 | 65.0 | 14.0 | 65.0 | 1.2 | 6.0 | 2.6 | 31.7 | 35.2 | 45 |
| | 460-3-60 | 15.0 | 59.0 | 15.0 | 59.0 | 1.1 | 5.5 | 2.2 | 33.2 | 37.1 | 50 |
| | 575-3-60 | 12.0 | 47.0 | 12.0 | 47.0 | 0.9 | 8.0 | 1.7 | 26.6 | 29.8 | 40 |
| 13F2 | 200/208-3-60 | 40.7 | 118.0 | 33.0 | 107.0 | 2.3 | 12.2 | 5.0 | 80.9 | 91.0 | 125 |
| | 230-3-60 | 36.8 | 130.0 | 30.0 | 118.0 | 2.2 | 11.0 | 4.3 | 73.2 | 82.5 | 110 |
| | 380-3-50 | 14.0 | 65.0 | 14.0 | 65.0 | 1.2 | 6.0 | 2.6 | 31.7 | 35.2 | 45 |
| | 460-3-60 | 18.4 | 65.0 | 15.0 | 59.0 | 1.1 | 5.5 | 2.2 | 36.6 | 34.1 | 50 |
| | 575-3-60 | 15.0 | 52.0 | 12.0 | 47.0 | 0.9 | 8.0 | 1.7 | 29.6 | 86.7 | 45 |
| 14F3 | 200/208-3-60 | 40.7 | 118.0 | 33.0 | 107.0 | 2.3 | 12.2 | 5.0 | 80.9 | 83.1 | 125 |
| | 230-3-60 | 36.8 | 130.0 | 30.0 | 118.0 | 2.2 | 11.0 | 4.3 | 73.2 | 38.7 | 110 |
| | 380-3-50 | 14.0 | 65.0 | 14.0 | 65.0 | 1.2 | 6.0 | 2.6 | 31.7 | 35.2 | 45 |
| | 460-3-60 | 18.4 | 65.0 | 15.0 | 59.0 | 1.1 | 5.5 | 2.2 | 36.6 | 41.3 | 50 |
| | 575-3-60 | 15.0 | 52.0 | 12.0 | 47.0 | 0.9 | 8.0 | 1.7 | 29.6 | 33.6 | 45 |

NOTES:

1. Table is appropriate for both Hot Water and Steam Units.
2. All purge pump electrical ratings are for the Welch model 1402.
3. A YORK supplied 100 amp, non-fused, unit disconnect switch is located in the power panel of all chiller models.

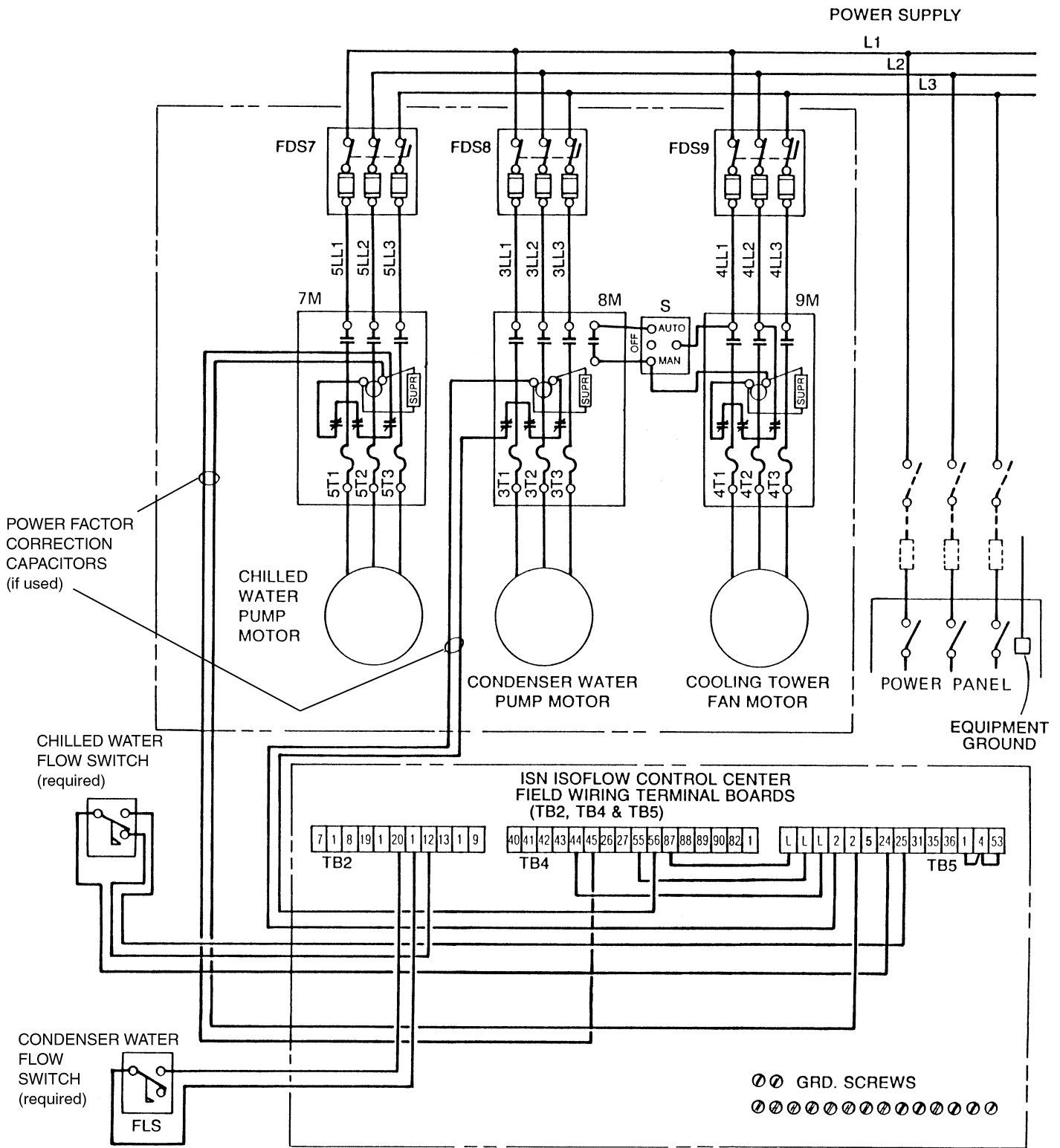

LD04574

FIG. 20 – SYSTEM WATER PUMP AND FLOW SWITCH INTERFACE DETAILS

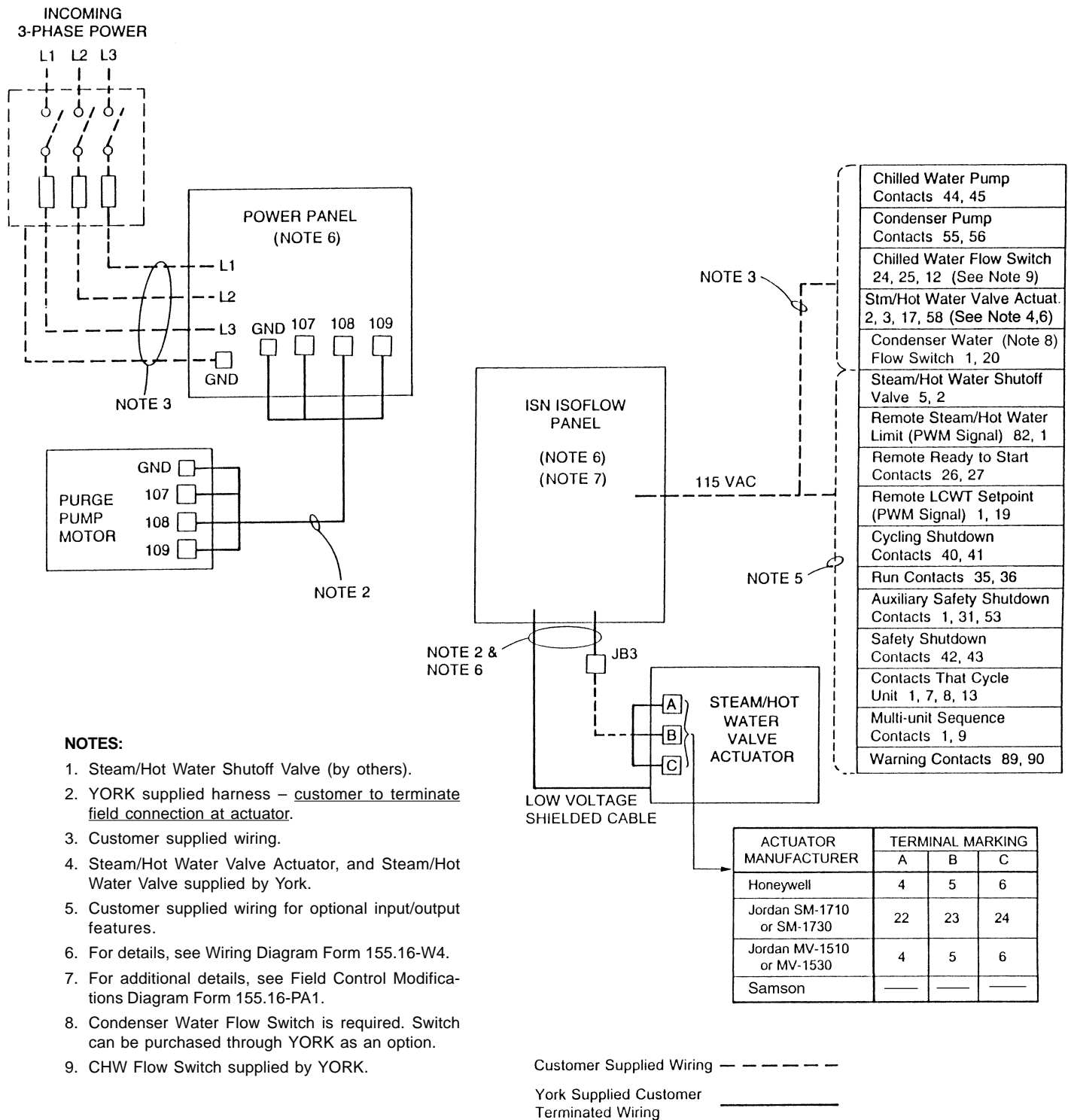

**All customer wiring must be copper.
All customer supplied wiring must conform to NEC as well as local codes.**

FIG. 21 – STEAM AND HOT WATER UNIT FIELD WIRING

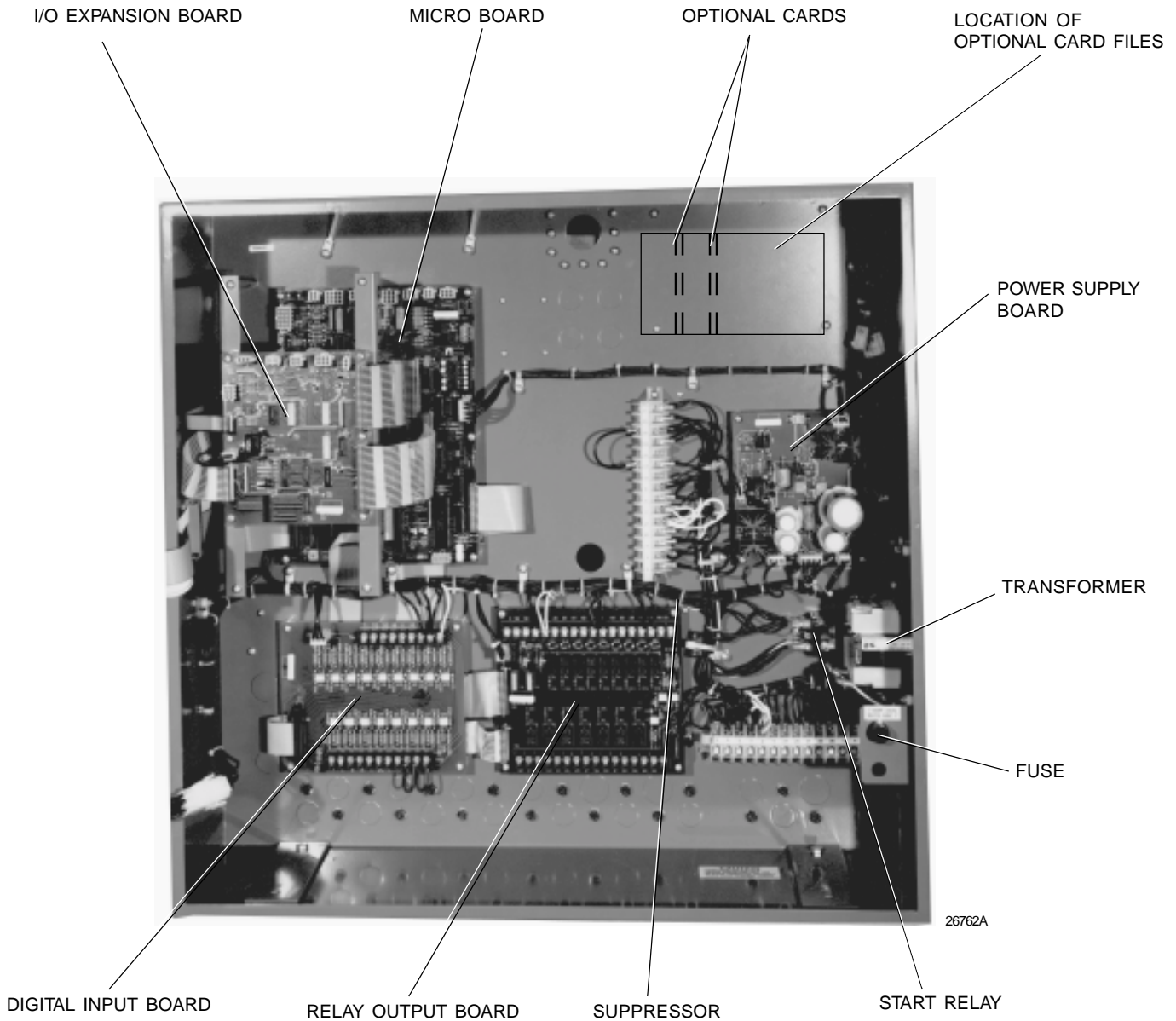
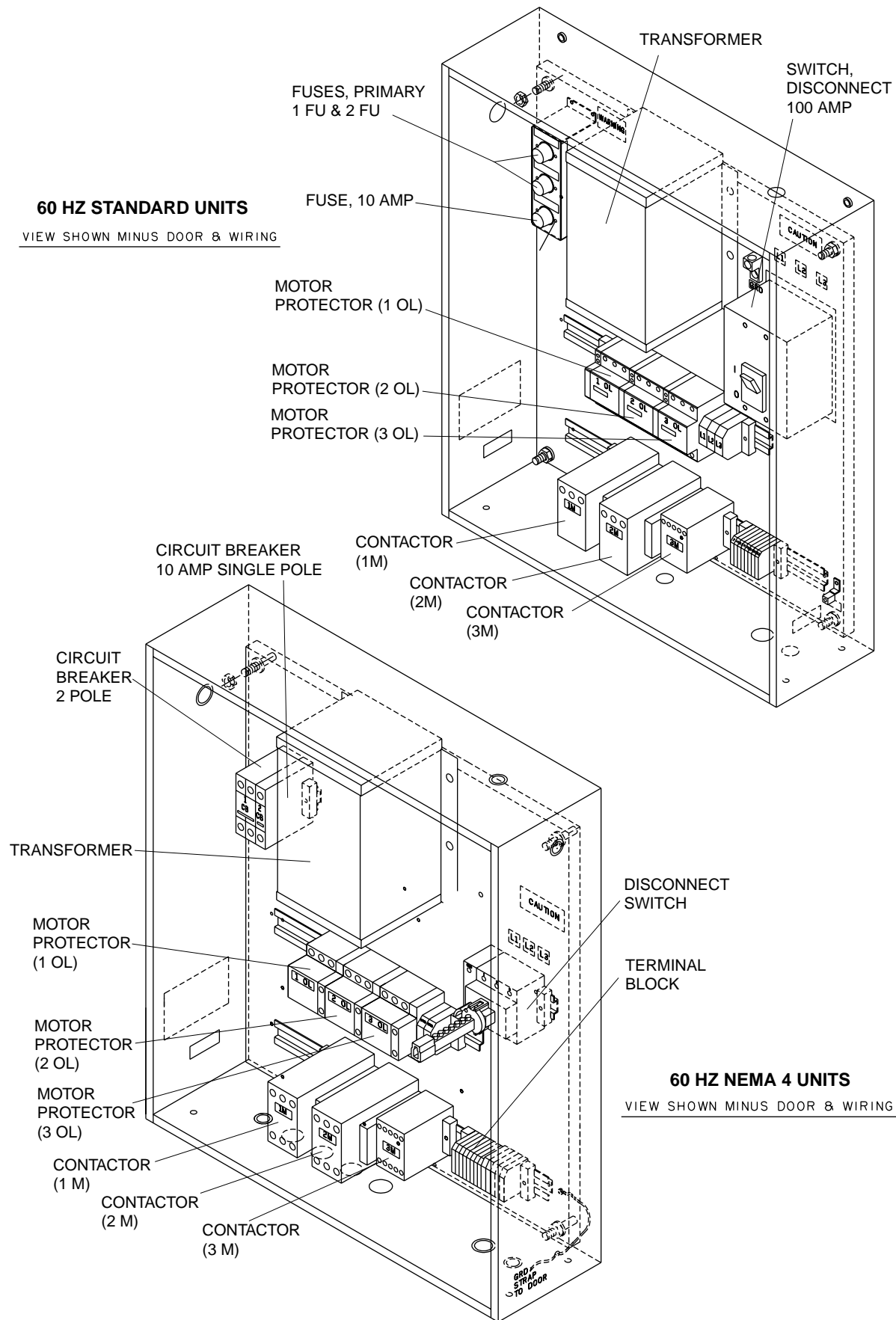
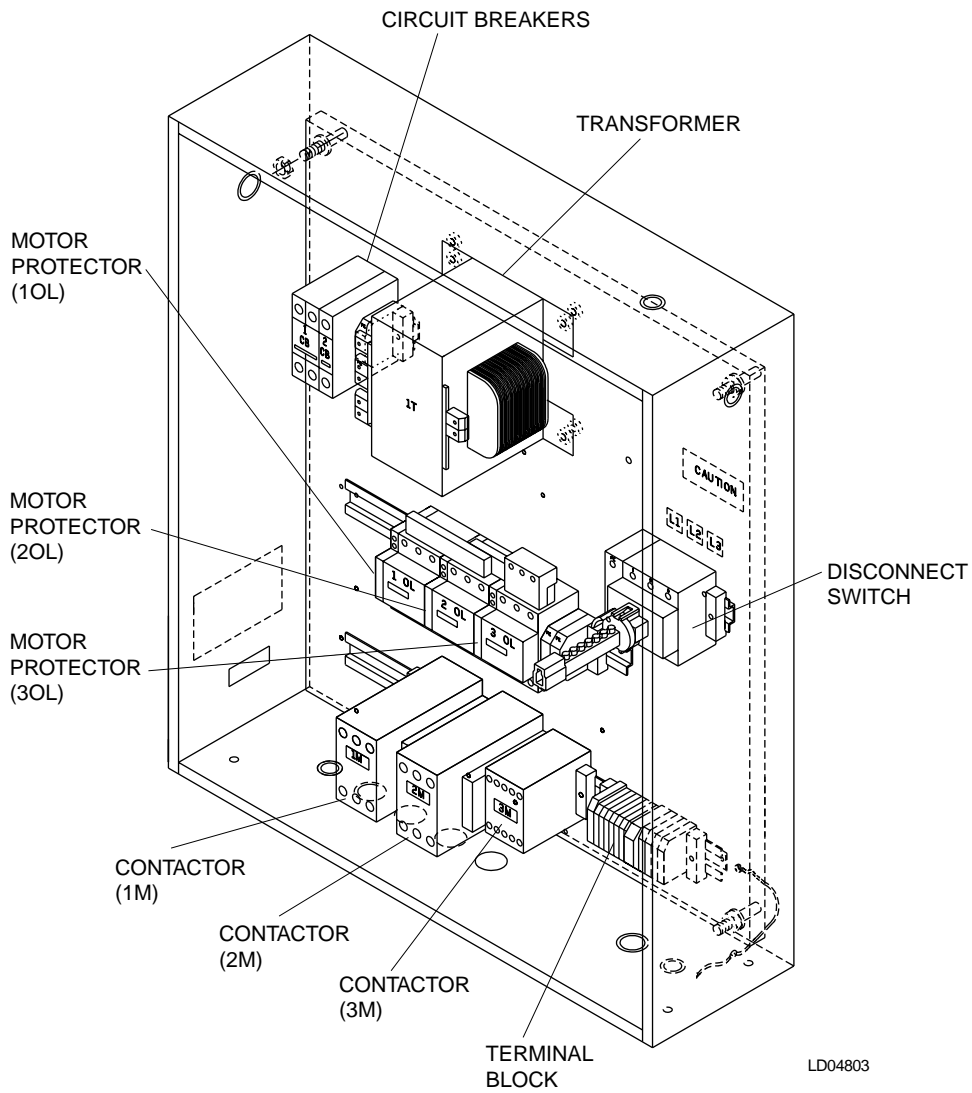

FIG. 22 – ISOFLOW MICRO PANEL CONTROL CENTER COMPONENT LOCATIONS



LD04738

FIG. 23 – ISOFLOW POWER PANEL COMPONENT LOCATIONS



LD04803

50 Hz, 380 volt
 (VDE and European compliance)
 view shown minus door and wiring

FIG. 24 – ISOFLOW POWER PANEL COMPONENT LOCATIONS

INSULATION

YORK recommends that all absorption equipment be insulated properly to optimize operating performance, insure the safety of operating and plant personnel, prevent sweating, and to prevent crystallization up to eight hours during a power failure. YORK performance ratings are based on a properly insulated chiller. Proper insulation limits the heat loss from the chiller to its surroundings. Insulation also protects personnel from the hot surfaces, such as the generator shell and steam/hot water piping and is often required for safety codes.

Insulating an IsoFlow™ absorption chiller requires two separate types of chiller insulation for both the hot and cold temperature surfaces. By insulating the hot surfaces, heat loss to the equipment room is minimized thereby maximizing efficiency and preventing hazardous working conditions. Cold insulation is applied to the chiller to prevent sweating.

For hot surfaces, YORK recommends using a 2 inch thick 3 lb. density fiberglass insulation. Hot surfaces that need insulation are the generator, generator heads, connecting piping, and the solution heat exchanger. Also, insulate the supply steam or hot water piping to the generator.

For cold surfaces, YORK recommends using 3/4 inch, closed-cell foam insulation. Cold surfaces that need insulation are the evaporator heads, refrigerant pump, evaporator overflow refrigerant box, innerconnecting piping between and around the refrigerant pump, and piping to evaporator sprays. As an optional purchase, these areas can be insulated at the factory.

In some rare cases, when the chiller is operating in high humid conditions, moisture in the surrounding air may condense on the evaporator surface. This is normally not so, because YORK uses a double-wall design in the evaporator section of the chiller to prevent sweating on the exterior evaporator surface. If it is preferred to insulate the evaporator surface, YORK recommends using the 3/4 inch, closed-cell foam insulation for this purpose.

INSULATION TIPS

Before proceeding with the unit insulation, please read the below for important information about certain precautions and warnings that must be adhered to.

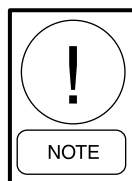

Insulation must not be applied to the chiller until start-up has been successfully completed by a qualified York service technician and chiller is operating with no indication of air leaks.

Glued insulation pins may be used for installing insulation to the chiller surface, **DO NOT USE WELD PINS.** A high temperature adhesive is available and recommended to adhere the insulation pins to the chiller surface (See Chemicals and Compounds section of the Renewal parts form for this epoxy). The surface of the insulation should be sealed vapor tight to prevent sweating and mildew underneath the insulation. All seams must be filled in using insulation tape or thermal mastic compound. Aluminum facing provides an additional layer of protection and a quality finish to the job.



Welding anything to the shell or using weld pins for insulation purposes, may penetrate the shell and may jeopardize the integrity of the chiller. Any welding to the chiller shell without written consent of York Factory Service will result in voiding all warranties.

When insulating the chiller, do not cover any sight glasses, hand valves, or water head bolts and nuts. These areas must be accessible for service and operating personnel. If insulation is desired in these areas, do not glue the insulation to the surface, in that way it can be easily removed for servicing the unit.

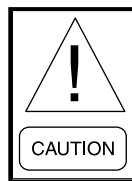

Never insulate the refrigerant or solution pump motors, these surfaces must be kept open to the surrounding air for cooling purposes.

Use Table 4 for purchasing and determining an approximate amount of hot or cold insulation for the York IsoFlow™ absorption chiller.

INSTALLATION CHECK LIST

At the back of this document is an Installation Check List which is to be used to insure that all installation items have been taken care of prior to contacting YORK for start-up supervision. When satisfied that the installation is complete, call for the services of a YORK representative by filling out and submitting the form at the back of this document. (See page 44.)

TABLE 4 – APPROXIMATE INSULATION FOR HOT AND COLD SURFACES

| Chiller Model | COLD SURFACES | | | | HOT SURFACES | |
|---------------|-------------------------------------|--------------------------------------|---|-----------------------------------|------------------------|------------------------|
| | Evap. Heads & End Sheets (Sq. Feet) | Refrig. Outlet Box & Pump (Sq. Feet) | Refrig. Suction & Discharge lines (Tubular insul.) (Dia. inch/lin feet) | Evap. Shell (optional) (Sq. Feet) | Upper Shell (Sq. Feet) | Evap. Heads (Sq. Feet) |
| 1A1 | 16 | 16 | 2"/11', 4"/4' | 52 | 70 | 2 |
| 1A2 | 16 | 16 | 2"/12', 4"/3' | 63 | 70 | 2 |
| 2A3 | 16 | 16 | 2"/12', 4"/3' | 73 | 81 | 2 |
| 2A4 | 16 | 16 | 2"/13', 4"/3' | 84 | 93 | 2 |
| 2B1 | 19 | 17 | 2"/9', 2-1/2"/4', 4"/4' | 84 | 95 | 3 |
| 3B2 | 19 | 17 | 2"/10', 2-1/2"/4', 4"/4' | 96 | 110 | 3 |
| 3B3 | 19 | 17 | 2"/11', 2-1/2"/4', 4"/4' | 108 | 125 | 3 |
| 4B4 | 19 | 18 | 2"/12', 2-1/2"/4', 4"/4' | 120 | 136 | 3 |
| 4C1 | 26 | 18 | 2-1/2"/11', 3"/4', 4"/6' | 111 | 132 | 4 |
| 5C2 | 26 | 18 | 2"/12', 3"/4', 4"/6' | 125 | 148 | 4 |
| 5C3 | 26 | 18 | 2-1/2"/13', 3"/4', 4"/6' | 139 | 165 | 4 |
| 6C4 | 26 | 18 | 2-1/2"/14', 3"/4', 4"/6' | 156 | 185 | 4 |
| 7D1 | 39 | 31 | 3"/17', 4"/6' | 156 | 180 | 7 |
| 7D2 | 39 | 31 | 3"/18', 4"/6' | 173 | 200 | 7 |
| 8D3 | 39 | 31 | 3"/19', 4"/6' | 194 | 225 | 7 |
| 8E1 | 55 | 43 | 3"/22', 4"/8' | 194 | 225 | 8 |
| 9E2 | 55 | 43 | 3"/24', 4"/8' | 218 | 255 | 8 |
| 10E3 | 55 | 43 | 3"/24' | 242 | 285 | 8 |
| 12F1 | 67 | 44 | 3"/21' | 242 | 290 | 10 |
| 13F2 | 67 | 44 | 3"/23' | 268 | 320 | 10 |
| 14F3 | 67 | 44 | 3"/24' | 295 | 355 | 10 |

NOTES:

1. Evaporator shell insulation is only required if evaporator shell surface sweats.
2. Cold surface insulation on the refrigerant outlet box, refrigerant pump, refrigerant pump suction and discharge lines may be purchased as an extra option from the factory.

TABLE 5 – UNIT CHARGE QUANTITIES

| Model Unit | Nominal Tonnage | Solution Charge | | | | | Refrigerant Charge | | | Unit ⁴ Alcohol Charge |
|------------|-----------------|--------------------|--------|---------|--------------------------|---------|--------------------|---------|--------------------------|----------------------------------|
| | | Charge Shipped | | | Unit Charge ³ | | Charge Shipped | | Unit ³ Charge | |
| | | Drums ¹ | Pounds | Gallons | Pounds | Gallons | Drums ² | Gallons | Gallons | Quarts |
| 1A1 | 120 | 4 | 1,608 | 120 | 1,474 | 110 | 1 | 55 | 22 | 2 |
| 1A2 | 155 | 5 | 2,010 | 150 | 1,742 | 130 | 1 | 55 | 33 | 2 |
| 2A3 | 172 | 5 | 2,010 | 150 | 1,876 | 140 | 1 | 55 | 37 | 2 |
| 2A4 | 205 | 6 | 2,412 | 180 | 2,278 | 170 | 1 | 55 | 41 | 2 |
| 2B1 | 235 | 7 | 2,814 | 210 | 2,546 | 190 | 1 | 55 | 52 | 3 |
| 3B2 | 273 | 8 | 3,216 | 240 | 2,948 | 220 | 2 | 110 | 56 | 3 |
| 3B3 | 311 | 8 | 3,216 | 240 | 3,216 | 240 | 2 | 110 | 62 | 3 |
| 4B4 | 334 | 9 | 3,618 | 270 | 3,618 | 270 | 2 | 110 | 69 | 3 |
| 4C1 | 363 | 10 | 4,020 | 300 | 3,752 | 280 | 2 | 110 | 57 | 4 |
| 5C2 | 410 | 11 | 4,422 | 330 | 4,422 | 330 | 2 | 110 | 63 | 4 |
| 5C3 | 446 | 12 | 4,824 | 360 | 4,824 | 360 | 2 | 110 | 72 | 4 |
| 6C4 | 518 | 14 | 5,628 | 420 | 5,494 | 410 | 2 | 110 | 85 | 4 |
| 7D1 | 565 | 14 | 5,628 | 420 | 5,494 | 410 | 2 | 110 | 96 | 5-1/2 |
| 7D2 | 617 | 16 | 6,432 | 480 | 6,164 | 460 | 2 | 110 | 108 | 5-1/2 |
| 8D3 | 704 | 17 | 6,834 | 510 | 6,834 | 510 | 3 | 165 | 121 | 5-1/2 |
| 8E1 | 794 | 21 | 8,442 | 630 | 8,442 | 630 | 3 | 165 | 141 | 6-1/2 |
| 9E2 | 908 | 24 | 9,648 | 720 | 9,514 | 710 | 3 | 165 | 162 | 6-1/2 |
| 10E3 | 960 | 26 | 10,452 | 780 | 10,452 | 780 | 3 | 165 | 183 | 6-1/2 |
| 12F1 | 1148 | 30 | 12,060 | 900 | 12,060 | 900 | 3 | 165 | 179 | 8 |
| 13F2 | 1235 | 34 | 13,668 | 1020 | 13,534 | 1010 | 3 | 165 | 199 | 8 |
| 14F3 | 1377 | 38 | 15,276 | 1140 | 15,008 | 1120 | 3 | 165 | 225 | 8 |

NOTES:

1. Solution drums are 30 gallon capacity.
2. Refrigerant drums are 55 gallon capacity.
3. The unit charge given in the table is typical only at unit start-up. Final trimming of solution and refrigerant may require more or less from the start-up amount.
4. Alcohol quantity in table includes the additional amount.

INSTALLATION CHECK LIST AND REQUEST FOR AUTHORIZED START-UP ENGINEER

To: _____ Job Name: _____
District Service & Maintenance Manager

Location: _____

Customer Order No. _____

York Tel. No. _____ York Order No. _____

ABSORPTION LIQUID CHILLER

Model No. _____ Serial No. _____

This work (as checked below) is in process and will be completed by _____
Month Day Year

The following work must be completed in accordance with YORK Installation Instructions for the above Model Absorption Unit.

- | | |
|--|---|
| <p>A. YORK ABSORPTION LIQUID CHILLER <input checked="" type="checkbox"/></p> <ol style="list-style-type: none"> 1. Unit mounted on a floor level to 1/4" <input type="checkbox"/> 2. Unit located in accordance with the minimum clearance dimensions as recommended in Table 1 <input type="checkbox"/> 3. Isolation pads under all four feet, if required <input type="checkbox"/> 4. If shipped in two sections, unit assembled under YORK supervision <input type="checkbox"/> 5. Unit installed in an area protected from weather and maintained at a temperature above freezing <input type="checkbox"/> <p>B. PIPING</p> <ol style="list-style-type: none"> 1. Condenser water piping installed between condenser, pumps and cooling tower <input type="checkbox"/> 2. Chilled water piping installed between cooler, pumps and cooling coils <input type="checkbox"/> 3. Steam or hot water piping installed between unit and source of supply <input type="checkbox"/> 4. Condensate traps and removal system installed <input type="checkbox"/> 5. Make-up and fill lines installed to cooling tower and chilled water system <input type="checkbox"/> 6. All thermometer wells and gauge connections installed in chilled and condenser water lines - trimmed as necessary <input type="checkbox"/> 7. All water piping checking for strain - Piping should not spring when connections are broken at unit <input type="checkbox"/> 8. Water piping leak tested and flushed, and water strainers cleaned after flushing. Piping systems filled with water and trapped air vented. <input type="checkbox"/> 9. Chilled and condenser water, hot water or steam flow available to meet unit design requirements. <input type="checkbox"/> 10. Pressure relief devices if used are vented to a safe area <input type="checkbox"/> | <p>C. ELECTRIC WIRING <input checked="" type="checkbox"/></p> <ol style="list-style-type: none"> 1. Main and control power supply available <input type="checkbox"/> 2. Wiring completed from main power supply to power panel - but not cut to final length or connected to panel <input type="checkbox"/> 3. 115 volt service completed to Control Center - but not connected <input type="checkbox"/> 4. External control wiring completed from Control Center to flow switch(es), pump motor starters, etc. in accordance with YORK wiring diagram <input type="checkbox"/> 5. Power available and wiring completed to the following starters and motors: <small>NOTE: Do not check unit pump motors rotation.</small> <ul style="list-style-type: none"> (a) Chilled water pumps <input type="checkbox"/> (b) Condenser water pumps <input type="checkbox"/> (c) Cooling tower fan (if used) <input type="checkbox"/> 6. Meg-ohm meter available for checking motor windows ... <input type="checkbox"/> <p>D. TESTING EVACUATING AND CHARGING (Under YORK Supervision Only.)</p> <ol style="list-style-type: none"> 1. R-22 available for testing <input type="checkbox"/> 2. Dry Nitrogen available for testing <input type="checkbox"/> 3. YORK Lithium Bromide charge inhibited with Lithium Molybdate is available for charging <input type="checkbox"/> 4. High vacuum pump available for evacuation <input type="checkbox"/> 5. 2-Ethyl/Hexanol additive is at the job site <input type="checkbox"/> <p>E. CONDITIONS</p> <ol style="list-style-type: none"> 1. YORK purge pump oil available on job <input type="checkbox"/> 2. Cooling load available for testing and operating the unit <input type="checkbox"/> 3. Personnel available for final wiring connections <input type="checkbox"/> 4. Personnel available for start-up and testing <input type="checkbox"/> 5. Owner's operating personnel available for instruction <input type="checkbox"/> <p style="margin-left: 20px;">Names _____</p> <p style="margin-left: 20px;">_____</p> <p style="margin-left: 20px;">_____</p> |
|--|---|

With reference to the terms of the above contract, we are requesting the presence of YORK Authorized Representative at the job site on _____ to start the system and instruct operating personnel. Have him contact _____
Month Day Year Names

We understand that the services of the YORK Authorized Representative will be furnished in accordance with the contract for a period of not more than _____ consecutive normal working hours; and we agree that a charge of _____ per diem plus travel and living expenses will be made to us by YORK if services are required for longer than _____ consecutive normal hours or if repeated calls are required through no fault of the YORK Corporation.

Signed _____ Title _____

