

YCWL0240SE-YCWL0395SE & YCWL / YCRL0200HE-YCWL / YCRL0610HE		
INSTALLATION, OPERATION & MAINTENANCE	Revision 5	Form 201.26-NM2 (0709)

035-21965-110

**WATER AND REMOTE AIR COOLED CHILLERS
WITH SCROLL COMPRESSORS
STYLE A
(188-580 KW)
SE - STANDARD EFFICIENCY & HE - HIGH EFFICIENCY**

Zafiro

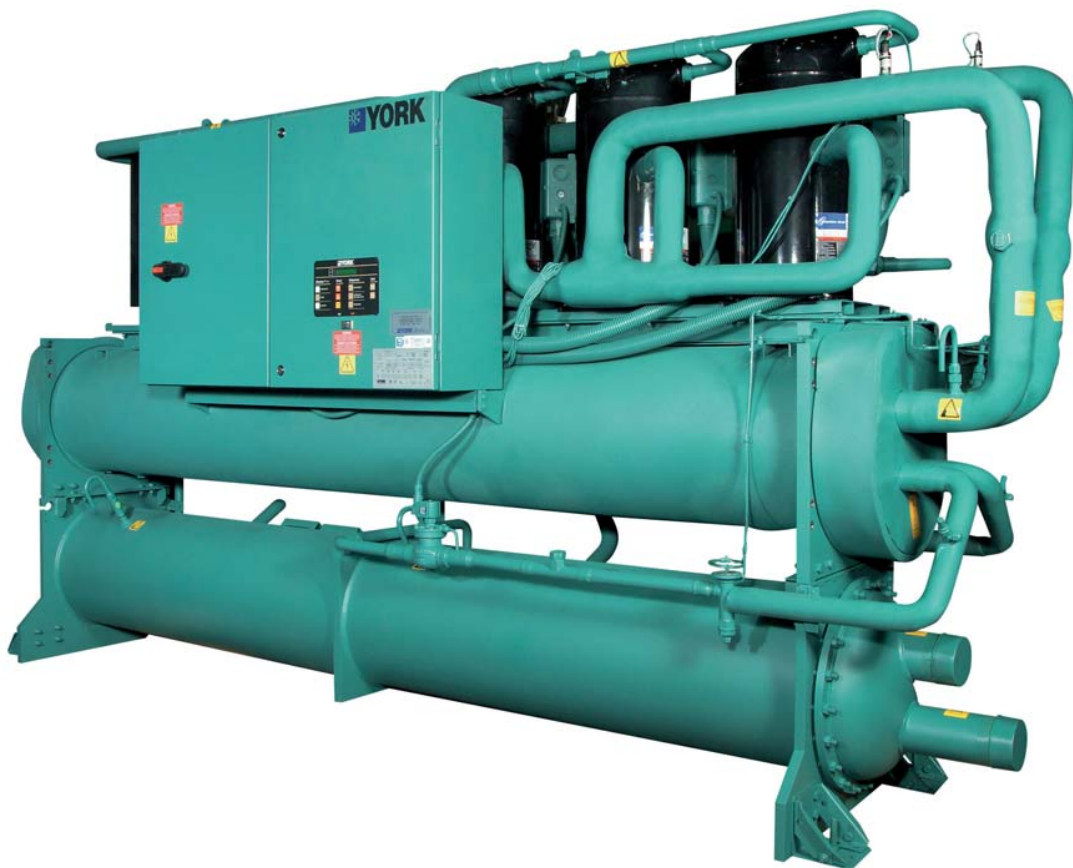

R410A

IMPORTANT!

Read BEFORE PROCEEDING!

GENERAL SAFETY GUIDELINES

This equipment is a relatively complicated apparatus. During installation, operation, maintenance or service, individuals may be exposed to certain components or conditions including, but not limited to: refrigerants, oils, materials under pressure, rotating components, and lethal voltage. Each of these items has the potential, if misused or handled improperly, to cause bodily injury or death. It is the obligation and responsibility of operating/service personnel to identify and recognize these inherent hazards, protect themselves, and proceed safely in completing their tasks. Failure to comply with any of these requirements could result in serious damage to the equipment and the property in which it is situated,

as well as severe personal injury or death to themselves and people at the site.

This document is intended for use by owner-authorized operating/service personnel. It is expected that this individual possesses independent training that will enable them to perform their assigned tasks properly and safely. It is essential that, prior to performing any task on this equipment, this individual shall have read and understood this document and any referenced materials. This individual shall also be familiar with and comply with all applicable governmental standards and regulations pertaining to the task in question.

SAFETY SYMBOLS

The following symbols are used in this document to alert the reader to areas of potential hazard:



DANGER indicates an imminently hazardous situation which, if not avoided, will result in death or serious injury.



CAUTION identifies a hazard which could lead to damage to the machine, damage to other equipment and/or environmental pollution. Usually an instruction will be given, together with a brief explanation.



WARNING indicates a potentially hazardous situation which, if not avoided, could result in death or serious injury.



NOTE is used to highlight additional information which may be helpful to you.



External wiring, unless specified as an optional connection in the manufacturer's product line, is not to be connected inside the micro panel cabinet. Devices such as relays, switches, transducers and controls may not be installed inside the panel. No external wiring is allowed to be run through the micro panel. All wiring must be in accordance with Johnson Controls published specifications and must be performed only by qualified Johnson Controls personnel. Johnson Controls will not be responsible for damages/problems resulting from improper connections to the controls or application of improper control signals. Failure to follow this will void the manufacturer's warranty and cause serious damage to property or injury to persons.

CHANGEABILITY OF THIS DOCUMENT

In complying with Johnson Controls policy for continuous product improvement, the information contained in this document is subject to change without notice. While Johnson Controls makes no commitment to update or provide current information automatically to the manual owner, that information, if applicable, can be obtained by contacting the nearest Johnson Controls Service Centre.

It is the responsibility of operating/service personnel to verify the applicability of these documents to the equipment in question. If there is any question in the mind of operating/service personnel as to the applicability of these documents, then prior to working on the equipment, they should verify with the owner whether the equipment has been modified and if current literature is available.

TABLE OF CONTENTS

<p>GENERAL SAFETY GUIDELINES 2</p> <p>SAFETY SYMBOLS..... 2</p> <p>CHANGEABILITY OF THIS DOCUMENT 3</p> <p>TABLE OF CONTENTS 4</p> <p>1 GENERAL CHILLER INFORMATION & SAFETY</p> <p>INTRODUCTION 6</p> <p>WARRANTY 6</p> <p>SAFETY 6</p> <p>Standards for Safety 6</p> <p>FLUORINATED GREENHOUSE GASES 7</p> <p>RESPONSIBILITY FOR SAFETY 7</p> <p>ABOUT THIS MANUAL 7</p> <p>MISUSE OF EQUIPMENT..... 8</p> <p>Suitability for Application 8</p> <p>Structural Support 8</p> <p>Mechanical Strength 8</p> <p>General Access..... 8</p> <p>Pressure Systems 8</p> <p>Electrical 8</p> <p>Refrigerants and Oils 8</p> <p>High Temperature and Pressure Cleaning..... 8</p> <p>Emergency Shutdown 8</p> <p>Safety Labels..... 9</p> <p>MATERIAL SAFETY DATA 10</p> <p>2 PRODUCT DESCRIPTION</p> <p>INTRODUCTION 15</p> <p>Compressors 15</p> <p>Refrigerant Circuits 16</p> <p>Evaporator..... 16</p> <p>Condenser (YCWL units only) 16</p> <p>Power and Control Panels..... 16</p> <p>The power panel includes: 16</p> <p>The control panel includes:..... 16</p> <p>The microprocessor control includes:..... 17</p> <p>Programmable setpoints: 17</p> <p>Displayed Data: 17</p> <p>Alarm Contacts: 17</p> <p>Soft Starters 18</p> <p>Power Factor Correction..... 18</p> <p>Language LCD and Keypad 18</p> <p>Non-reversible Heat Pump..... 18</p> <p>38 mm Evaporator Insulation 18</p> <p>Pressure Relief (CE/PED) Service Valve Kit 18</p> <p>Dual Pressure Relief Valves..... 18</p>	<p>Suction Service Valves..... 18</p> <p>Victaulic Flange Kit 18</p> <p>Compressor Acoustic Blankets 18</p> <p>Final overspray 18</p> <p>Flow switch..... 18</p> <p>Differential Pressure Switch 18</p> <p>Neoprene Pad Isolators 18</p> <p>25 mm Spring Isolators..... 18</p> <p>Electronic Expansion Valve 18</p> <p>YCWL..... 19</p> <p>YCRL..... 19</p> <p>UNIT MODEL NUMBER NOMENCLATURE 20</p> <p>NOMENCLATURE..... 20</p> <p>3 HANDLING AND STORAGE</p> <p>DELIVERY AND STORAGE 21</p> <p>INSPECTION 21</p> <p>MOVING THE CHILLER 21</p> <p>Lifting by Crane/Hoist 21</p> <p>Lifting by Fork lift 21</p> <p>LIFTING WEIGHTS 21</p> <p>4 INSTALLATION</p> <p>Location Requirements 23</p> <p>Installation of Vibration Isolators 23</p> <p>Pipework Connection..... 23</p> <p>Water Treatment..... 24</p> <p>Chilled Liquid System 24</p> <p>Connection Types & Sizes 25</p> <p>Refrigerant Relief Valve Piping 25</p> <p>Condenser Cooling Liquid Systems 26</p> <p>Inlet Temperature Control (by others) 26</p> <p>CONDENSERLESS UNIT REFRIGERANT PIPING 27</p> <p>General 27</p> <p>Refrigerant Line Sizing..... 27</p> <p>Chiller Below Condenser..... 27</p> <p>Condenser Below Chiller..... 27</p> <p>Oil traps 27</p> <p>Refrigerant Charge..... 27</p> <p>ELECTRICAL CONNECTION 27</p> <p>Power Wiring 27</p> <p>Single Point Power Supply Wiring 28</p> <p>Remote Emergency Stop Device 28</p> <p>Control Wiring - Voltage Free Contacts..... 28</p> <p>Chilled Liquid Pump Starter 28</p> <p>Run Contacts..... 28</p> <p>Alarm Contacts 28</p>
--	--

Control Wiring - System Inputs	28
Flow Switch	28
Remote Start/Stop	28
Remote Reset of Chilled Liquid Setpoint	28
Remote Load Limiting	29
Heat Pump Kit	29
EMS Analogue Input	29
BACnet/Modbus	29
CONNECTION DIAGRAM	30

5 COMMISSIONING

PREPARATION.....	31
Preparation - Power Off.....	31
Soft Start (Option)	32
THE MACHINE IS NOW LIVE!	32
FIRST TIME START-UP.....	33

6 TECHNICAL DATA

PRESSURE DROP GRAPHS	35
OPERATING LIMITATIONS	36
PHYSICAL DATA	38
ELECTRICAL DATA	40
DIMENSIONS	42
DIMENSIONS - YCWL0385HE, YCWL0445HE, WEIGHT DISTRIBUTION & VIBRATION ISOLATOR DATA	50

7 UNIT OPERATION

GENERAL DESCRIPTION	63
START-UP	63
NORMAL RUNNING AND CYCLING.....	63
SHUTDOWN.....	63

8 MAINTENANCE

GENERAL REQUIREMENTS	65
DAILY MAINTENANCE	65
SCHEDULED MAINTENANCE	65
Evaporator/Condenser In-Service Inspection	66

9 TROUBLE SHOOTING

Competent Persons Trouble Shooting Guide.....	67
Sensor Calibration Charts	69
Leaving Liquid Temperature (-BLLT)	69
Discharge Pressure (-BDP) and Suction (-BSP) Transducers	69

SPARE PARTS

RECOMMENDED SPARES	71
RECOMMENDED COMPRESSOR OIL	71
ASSOCIATED DRAWINGS	71
DECOMMISSIONING, DISMANTLING AND DISPOSAL.....	73
GENERAL	73

GENERAL CHILLER INFORMATION & SAFETY

INTRODUCTION

YORK YCWL chillers are manufactured to the highest design and construction standards to ensure high performance, reliability and adaptability to all types of air conditioning installations.

The unit is intended for cooling water or glycol solutions and is not suitable for purposes other than those specified in this manual.

This manual contains all the information required for correct installation and commissioning of the unit, together with operating and maintenance instructions. The manuals should be read thoroughly before attempting to operate or service the unit.

All procedures detailed in the manuals, including installation, commissioning and maintenance tasks must only be performed by suitably trained and qualified personnel.

The manufacturer will not be liable for any injury or damage caused by incorrect installation, commissioning, operation or maintenance resulting from a failure to follow the procedures and instructions detailed in the manuals.

WARRANTY

Johnson Controls warrants all equipment and materials against defects in workmanship and materials for a period of eighteen months from date of shipment, unless labor or extended warranty has been purchased as part of the contract.

The warranty is limited to parts only replacement and shipping of any faulty part, or sub-assembly, which has failed due to poor quality or manufacturing errors. All claims must be supported by evidence that the failure has occurred within the warranty period, and that the unit has been operated within the designed parameters specified.

All warranty claims must specify the unit model, serial number, order number and run hours/starts. Model and serial number information is printed on the unit identification plate.

The unit warranty will be void if any modification to the unit is carried out without prior written approval from Johnson Controls.

For warranty purposes, the following conditions must be satisfied:

- The initial start of the unit must be carried out by trained personnel from an Authorized Johnson Controls Service Centre. See Section 5, Commissioning.
- Only genuine Johnson Controls approved spare parts, oils, coolants, and refrigerants must be used. Recommendations on spare parts stocking can be found in Section 7, Maintenance.
- All the scheduled maintenance operations detailed in this manual must be performed at the specified times by suitably trained and qualified personnel. See Section 7, Maintenance,

Failure to satisfy any of these conditions will automatically void the warranty. See Warranty Policy (Section 7, Maintenance).

SAFETY

Standards for Safety

YCWL and YCRL chillers are designed and built within an EN ISO 9002 accredited manufacturing organisation.

Chillers conform with the following European Directives:

- Machinery Directive (98/37/EC)
- Low Voltage Directive (2006/95/EC)
- EMC Directive (2004/108/EC)
- Pressure Equipment Directive (97/23/EC)

Or conversely comply with the applicable sections of the following Standards and Codes:

- ANSI/ASHRAE Standard 15 - Safety Code for Mechanical Refrigeration.
- ASHRAE 90.1 - Energy Efficiency Compliance.
- ANSI/NFPA Standard 70 - National Electrical Code (N.E.C.).
- ASME Boiler and Pressure Vessel Code, Section VIII Division 1.
- ASHRAE 34 - Number Designation and Safety Classification of Refrigerants.

- ARI Standard 550/590 - Positive Displacement Compressors and Water Cooled Rotary Screw Water Chilling Packages.
- Conform to UL code 1995 for construction of chillers and provide ETL/cETL listing label.
- OSHA - Occupied Safety and Health Act.
- ARI 370 Sound Rating of Large Outdoor Refrigeration and Air Conditioning Equipment.

FLUORINATED GREENHOUSE GASES

- This equipment contains fluorinated greenhouse gases covered by the Kyoto Protocol.
- The global warming potential of the refrigerant (R410A) used in this unit is 1720.
- The refrigerant quantity is stated in the Physical Data table in Section 9 of this document.
- The fluorinated greenhouse gases in this equipment may not be vented to the atmosphere.
- This equipment should only be serviced by qualified technicians.

RESPONSIBILITY FOR SAFETY

Every care has been taken in the design and manufacture of the unit to ensure compliance with the safety requirements listed above. However, the individual operating or working on any machinery is primarily responsible for:

- Personal safety, safety of other personnel, and the machinery.
- Correct utilization of the machinery in accordance with the procedures detailed in the manuals.

ABOUT THIS MANUAL

The following terms are used in this document to alert the reader to areas of potential hazard.



A WARNING is given in this document to identify a hazard, which could lead to personal injury. Usually an instruction will be given, together with a brief explanation and the possible result of ignoring the instruction.



A CAUTION identifies a hazard which could lead to damage to the machine, damage to other equipment and/or environmental pollution. Usually an instruction will be given, together with a brief explanation and the possible result of ignoring the instruction.



A NOTE is used to highlight additional information, which may be helpful to you but where there are no special safety implications.

The contents of this manual include suggested best working practices and procedures. These are issued for guidance only, and they do not take precedence over the above stated individual responsibility and/or local safety regulations.

This manual and any other document supplied with the unit are the property of Johnson Controls which reserves all rights. They may not be reproduced, in whole or in part, without prior written authorization from an authorized Johnson Controls representative.

MISUSE OF EQUIPMENT

Suitability for Application

The unit is intended for cooling water or glycol solutions and is not suitable for purposes other than those specified in these instructions. Any use of the equipment other than its intended use, or operation of the equipment contrary to the relevant procedures may result in injury to the operator, or damage to the equipment.

The unit must not be operated outside the design parameters specified in this manual.

Structural Support

Structural support of the unit must be provided as indicated in these instructions. Failure to provide proper support may result in injury to the operator, or damage to the equipment and/or building.

Mechanical Strength

The unit is not designed to withstand loads or stresses from adjacent equipment, pipework or structures. Additional components must not be mounted on the unit. Any such extraneous loads may cause structural failure and may result in injury to the operator, or damage to the equipment.

General Access

There are a number of areas and features, which may be a hazard and potentially cause injury when working on the unit unless suitable safety precautions are taken. It is important to ensure access to the unit is restricted to suitably qualified persons who are familiar with the potential hazards and precautions necessary for safe operation and maintenance of equipment containing high temperatures, pressures and voltages.

Pressure Systems

The unit contains refrigerant vapor and liquid under pressure, release of which can be a danger and cause injury. The user should ensure that care is taken during installation, operation and maintenance to avoid damage to the pressure system. No attempt should be made to gain access to the component parts of the pressure system other than by suitably trained and qualified personnel.

Electrical

The unit must be earthed. No installation or maintenance work should be attempted on the electrical equipment without first switching power OFF, isolating and locking-off the power supply. Servicing and maintenance on live equipment must only be performed by suitably trained and qualified personnel. No attempt should be made to gain access to the control panel or electrical enclosures during normal operation of the unit.

Refrigerants and Oils

Refrigerants and oils used in the unit are generally nontoxic, non-flammable and non-corrosive, and pose no special safety hazards. Use of gloves and safety glasses is, however, recommended when working on the unit. The build up of refrigerant vapor, from a leak for example, does pose a risk of asphyxiation in confined or enclosed spaces and attention should be given to good ventilation.

High Temperature and Pressure Cleaning

High temperature and pressure cleaning methods (e.g. steam cleaning) should not be used on any part of the pressure system as this may cause operation of the pressure relief device(s). Detergents and solvents, which may cause corrosion, should also be avoided.

Emergency Shutdown

In case of emergency, the control panel is fitted with a incoming supply non-fused disconnect switch which can be used as the emergency stop device. When operated it removes the electrical supply to the control circuit thus shutting down the unit.

Safety Labels

The following labels are fixed to each unit to give instruction, or to indicate potential hazards which may exist.



White symbol on blue background
For safe operation, read the Instructions first



Black symbol on yellow background
Warning: This machine may start automatically without prior warning



Black symbol on yellow background
Warning: Hot surface



Black symbol on yellow background
Warning: Safety relief valve may discharge gas or liquid without prior warning



Black symbol on yellow background
Warning: Isolate all electrical sources of supply before opening or removing the cover, as lethal voltages may exist



Black symbol on yellow background
General attention symbol

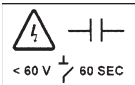

Black symbol on yellow background
Power Factor Correction fitted
Warning: On isolating the supply it may take up to 60 seconds for the capacitor voltage to fall below 60 volts

MATERIAL SAFETY DATA

Refrigerant Safety Data R410A:	
COMPOSITION/INFORMATION ON INGREDIENTS	
Components Material	PENTAFLUOROETHANE (HFC-125) DIFLUOROMETHANE (HFC-32)
CAS Number	354-33-6 75-10-5
%	50 50
HAZARDS IDENTIFICATION	
Potential Health Effects	Inhalation of high concentrations of vapour is harmful and may cause heart irregularities, unconsciousness, or death. Intentional misuse or deliberate inhalation may cause death without warning. Vapour reduces oxygen available for breathing and is heavier than air. Liquid contact can cause frostbite. At flame temperatures, this material can decompose to hydrogen fluoride which can be lethal at much lower concentrations.
Human Health Effects	Overexposure to the vapours by inhalation may include temporary nervous system depression with anaesthetic effects such as dizziness, headache, confusion, incoordination, and loss of consciousness. Higher exposures to the vapours may cause temporary alteration of the heart's electrical activity with irregular pulse, palpitations, or inadequate circulation. Gross overexposure may be fatal. Skin contact with the liquid may cause frostbite. Individuals with preexisting diseases of the central nervous or cardiovascular system may have increased susceptibility to the toxicity of increased exposures.
Carcinogenicity Information	None of the components present in this material at concentrations equal to or greater than 0.1% are listed by IARC, NTP, OSHA or ACGIH as a carcinogen.
FIRST AID MEASURES	
Inhalation	If inhaled, immediately remove to fresh air. Keep person calm. If not breathing, give artificial respiration. If breathing is difficult, give oxygen. Call a physician.
Skin Contact	Flush area with lukewarm water. Do not use hot water. If frostbite has occurred, call a physician.
Eye Contact	In case of contact, immediately flush eyes with plenty of water for at least 15 minutes. Call a physician.
Ingestion	Do not induce vomiting. Give plenty of water in sips
Notes to Physicians	THIS MATERIAL MAY MAKE THE HEART MORE SUSCEPTIBLE TO ARRHYTHMIAS. Catecholamines such as adrenaline, and other compounds having similar effects, should be reserved for emergencies and then used only with special caution.
FIRE FIGHTING MEASURES	
Flammable Properties	Flash Point : No flash point Flammable Limits in Air, % by Volume: LEL : None per ASTM E681 UEL : None per ASTM E681 Autoignition: Not determined
Fire and Explosion Hazards	Cylinders may rupture under fire conditions. Decomposition may occur. Contact of welding or soldering torch flame with high concentrations of refrigerant can result in visible changes in the size and colour of torch flames. This flame effect will only occur in concentrations of product well above the recommended exposure limit, therefore stop all work and ventilate to disperse refrigerant vapours from the work area before using any open flames. R-410A is not flammable in air at temperatures up to 100 deg C (212 deg F) at atmospheric pressure. However, mixtures of R-410A with high concentrations of air at elevated pressure and/or temperature can become combustible in the presence of an ignition source. R-410A can also become combustible in an oxygen enriched environment (oxygen concentrations greater than that in air). Whether a mixture containing R-410A and air, or R-410A in an oxygen enriched atmosphere becomes combustible depends on the inter-relationship of 1) the temperature 2) the pressure, and 3) the proportion of oxygen in the mixture. In general, R-410A should not be allowed to exist with air above atmospheric pressure or at high temperatures; or in an oxygen enriched environment. For example: R-410A should NOT be mixed with air under pressure for leak testing or other purposes.

Refrigerant Safety Data R410A:	
Extinguishing Media	As appropriate for combustibles in area.
Fire Fighting Instructions	Cool cylinder with water spray or fog. Self-contained breathing apparatus (SCBA) is required if cylinders rupture and contents are released under fire conditions. Water runoff should be contained and neutralized prior to release.
ACCIDENTAL RELEASE MEASURES	
Safeguards (Personnel)	NOTE: Review FIRE FIGHTING MEASURES and HANDLING (PERSONNEL) sections before proceeding with clean-up. Use appropriate PERSONAL PROTECTIVE EQUIPMENT during clean-up.
Accidental Release Measures	Ventilate area, especially low or enclosed places where heavy vapours might collect. Extinguish open flames. Use self-contained breathing apparatus (SCBA) for large spills or releases. Eliminate electrical sources.
HANDLING AND STORAGE	
Handling (Personnel)	Avoid breathing vapour. Avoid liquid contact with eyes and skin. Use with sufficient ventilation to keep employee exposure below recommended limits. See Fire and Explosion Data section.
Storage	Clean, dry area. Do not heat above 52 deg C (125 deg F).
EXPOSURE CONTROLS/PERSONAL PROTECTION	
Engineering Controls	Avoid breathing vapours. Avoid contact with skin or eyes. Use with sufficient ventilation to keep employee exposure below the recommended exposure limit. Local exhaust should be used if large amounts are released. Mechanical ventilation should be used in low or enclosed places.
Personal Protective Equipment	Impervious gloves should be used to avoid prolonged or repeated exposure. Chemical splash goggles should be available for use as needed to prevent eye contact. Under normal manufacturing conditions, no respiratory protection is required when using this product provided exposure is maintained at or below occupational limits. Self-contained breathing apparatus (SCBA) is required if a large release occurs.
Exposure Guidelines	Applicable Exposure Limits PENTAFLUOROETHANE (HFC-125) PEL (OSHA) : None Established TLV (ACGIH) : None Established AEL * (DuPont) : 1000 ppm, 8 & 12 Hr. TWA WEEL (AIHA) : 1000 ppm, 4900 mg/m ³ , 8 Hr. TWA DIFLUOROMETHANE (HFC-32) AEL * (DuPont) : 1000 ppm, 8 & 12 Hr. TWA WEEL (AIHA) : 1000 ppm, 8 Hr. TWA * AEL is DuPont's Acceptable Exposure Limit. Where governmentally imposed occupational exposure limits which are lower than the AEL are in effect, such limits shall take precedence.
PHYSICAL AND CHEMICAL PROPERTIES	
Physical Data	Boiling Point : - 60.8 F (-51.6 C) @ 1 atm Vapour Pressure : 239.7 psia 25 C (77 F) % Volatiles : 100 WT% Evaporation Rate : (Cl4 = 1) Greater than 1 Solubility in Water : Not determined Odour : Slight ethereal Form : Liquefied gas Colour : Clear, colourless Specific Gravity : 1.066 @ 25 C (77 F)
STABILITY AND REACTIVITY	
Chemical Stability	Material is stable. However, avoid open flames and high temperatures.
Incompatibility with Other Materials	Incompatible with active metals, alkali or alkaline earth metals--powdered Al, Zn, Be, etc.
Decomposition	Decomposition products are hazardous. This material can be decomposed by high temperatures (open flames, glowing metal surfaces, etc.) forming hydrofluoric acid and possibly carbonyl fluoride. These materials are toxic and irritating. Contact should be avoided.

Refrigerant Safety Data R410A:	
Polymerization	Polymerization will not occur.
Other Hazards	Decomposition : Decomposition products are hazardous. This material can be decomposed by high temperatures (open flames, glowing metal surfaces, etc.) forming hydrofluoric acid, and possibly carbonyl halides.
TOXICOLOGICAL INFORMATION	
Animal Data	<p>The blend is untested.</p> <p>HFC-125 Inhalation 4-hour ALC: >709,000 ppm in rats Single exposure to high doses caused: Lethargy. Laboured breathing. Weak cardiac sensitization, a potentially fatal disturbance of heart rhythm caused by a heightened sensitivity to the action of epinephrine. Lowest-Observed-Adverse-Effect-Level for cardiac sensitization: 100,000 ppm. Repeated exposure caused: No significant toxicological effects. No-Observed-Adverse-Effect-Level(NOAEL): 50,000 ppm</p> <p>ADDITIONAL TOXICOLOGICAL EFFECTS: No animal data are available to define the following effects of this material: carcinogenicity, reproductive toxicity. In animal testing this material has not caused developmental toxicity. Tests have shown that this material does not cause genetic damage in bacterial or mammalian cell cultures, or in animals. This material has not been tested for its ability to cause permanent genetic damage in reproductive cells of mammals (not tested for heritable genetic damage).</p> <p>HFC-32 Inhalation 4 hour-ALC: > 520,000 ppm in rats Single exposure caused: Lethargy. Spasms. Loss of mobility in the hind limbs. Other effects include weak cardiac sensitization, a potentially fatal disturbance of heart rhythm caused by a heightened sensitivity to the action of epinephrine. 250,000 ppm. Repeated exposure caused pathological changes of the lungs, liver, spleen, kidneys. In more recent studies repeated exposure caused: No significant toxicological effects.</p> <p>No-Observed-Effect-Level (NOEL): 49,100 ppm. No animal data are available to define the following effects of this material: carcinogenicity, reproductive toxicity. Animal data show slight fetotoxicity but only at exposure levels producing other toxic effects in the adult animal. Tests have shown that this material does not cause genetic damage in bacterial or mammalian cell cultures, or in animals. This material has not been tested for its ability to cause permanent genetic damage in reproductive cells of mammals (not tested for heritable genetic damage).</p>
DISPOSAL CONSIDERATIONS	
Waste Disposal	Comply with Federal, State, and local regulations. Reclaim by distillation or remove to a permitted waste disposal facility.
TRANSPORTATION INFORMATION	
Shipping Information	<p>DOT/IMO/IATA Proper Shipping Name : Liquefied Gas, N.O.S. (Pentafluoroethane and Difluoromethane)</p> <p>Hazard Class : 2.2 UN No. : 3163 Label(s) : Nonflammable Gas Shipping Containers : Tank Cars. Cylinders. Ton Tanks</p>

Oil Safety Data YORK 'V' Oil:
Section 1 Substance Product Information
Product Trade Name: YORK "V" Oil. Chemical Name: Carboxylic Ester.
Section 2 Components and Hazard Statement
This product is non-hazardous. This material has no known hazards under applicable laws.
Section 3 Safe Handling and Storage
Handling: Keep containers closed when not in use. Wash thoroughly after handling. Empty container contains product Storage: No special storage precautions required.
Section 4 Physical Data
Appearance: Clear liquid. Boiling Point: Not Determined. Vapour Pressure: Not Determined. Specific Gravity (water=1): 0.97 @ 15.6°C. Volatiles, Percent by Volume: Unknown. Odour: Mild. Solubility in Water: Insoluble. Evaporation Rate: Not Determined.
Section 5 Fire and Explosion Hazards
Flash Point: > 232°C, 450°F COC (Minimum). Flammable Limits: not established. Autoignition Temperature: no data. Extinguishing Media: CO ₂ , dry chemical or foam. Water can be used to cool and protect exposed material. Unusual Fire and Explosion Hazards: Toxic fumes, gases or vapours may evolve on burning. Special Fire Fighting Techniques: Firefighters should use approved self-contained breathing apparatus. Water may cause
Section 6 Reactivity Data
Stability: Material is normally stable at moderately elevated temperatures and pressures. Hazardous Polymerization: Will not occur. Incompatible Materials: Strong acids. Strong bases. Strong oxidizing agents. Decomposition Temperature: Not Determined. Thermal Decomposition: Smoke, carbon monoxide, carbon dioxide, aldehydes and other products of incomplete combustion.
Section 7 Health Hazard Data
First Aid Procedures
Ingestion: DO NOT INDUCE VOMITING. If conscious, give 2 glasses of water. Get immediate medical attention. Eyes: Flush with water at least 15 minutes. Get medical attention if eye irritation develops or persists. Skin: Wash with soap and water. Get medical attention if irritation develops. Launder contaminated clothing before reuse. Inhalation: Remove exposed person to fresh air if adverse effects are observed. Additional Information: Note to physician: Treat symptomatically.
Section 8 Personal Protection Information
Respiratory Protection: Use respirator with an organic vapour cartridge if exposure limit is exceeded. Ventilation: Use with adequate ventilation. Protective Gloves: Neoprene. Eye/Face Protection: Safety glasses. Clothing: Long sleeve shirt is recommended.
Section 9 Spill or Leak Procedures
Spill Procedures: Personal Protective Equipment must be worn, see Personal Protection Information (Section 8). Ventilate
Section 10 Waste Disposal Methods
This material, if discarded, should be disposed of in a licensed facility in accordance with local regulations.

Thermal & Acoustic Materials Data	
Health Hazard & First Aid	Toxicity Index <10 to NES713 Issue 3 (1991): Non-hazardous, non-toxic. No first aid necessary.
Stability / Reactivity	Stable.
Handling / Use / Disposal	No special handling precautions required. Dispose of according to local laws and regulations governing non-biodegradable non-hazardous solid wastes.
Fire & Explosion	Flammability rating Class 1 to BS 476 pt 7: Non-flammable. If forced to burn, combustion products are typically over 95% carbon dioxide and carbon monoxide.

PRODUCT DESCRIPTION



2

INTRODUCTION

YORK Zafiro 410A chillers are designed for water or water-glycol cooling.

All units are designed for indoor installation in a plant room.

The YCWL unit is completely factory assembled with all interconnecting refrigerant piping and wiring ready for field installation. The unit is pressure tested, evacuated, and fully factory charged with refrigerant R410A and oil in each of the independent refrigerant circuits. After assembly, an operational test is performed with water flowing through the evaporator and condenser to ensure that each refrigerant circuit operates correctly. The YCRL unit is completely factory assembled with all interconnecting refrigerant piping and internal wiring, ready for field connection to a remote condenser. The unit is pressure-tested, evacuated, and charged with a nitrogen holding charge and oil in each of the independent refrigerant circuits.

The unit structure is manufactured from heavy-gauge, galvanised steel coated with baked-on 'Caribbean Blue' powder paint.

Compressors

The unit has suction-cooled, hermetic scroll compressors. High efficiency is achieved through a controlled orbit and the use of advanced scroll geometry. The compressors incorporate a compliant scroll design in both the axial and radial directions. All rotating parts are statically and dynamically balanced. The compressor motors have integral protection against overloads. The overload protection that will automatically reset. Starting is direct on line, but soft start is available as an option.

The compressors are switched On and Off by the unit microprocessor to provide capacity control. Each compressor is fitted with a crankcase strap heater. All compressors are mounted on isolator pads to reduce transmission of vibration to the rest of the unit.

Refrigerant Circuits

Two independent refrigerant circuits are provided on each unit. Each circuit uses copper refrigerant pipe formed on computer controlled bending machines to reduce the number of brazed joints resulting in a reliable and leak resistant system.

Liquid line components include: a service valve with charging port, a high absorption removable core filter-drier, a solenoid valve, a sight glass with moisture indicator and a thermal expansion valve. Liquid lines between the expansion valve and the cooler are covered with flexible, closed-cell insulation.

Suction line components include: a pressure relief valve, a pressure transducer and a service valve. Optional isolation ball valves are available. Suction lines are covered with flexible, closed-cell insulation.

Discharge lines include service and isolation (ball) valves, two high-pressure cutout switches, a pressure transducer and a pressure relief valve. (YCWL units only).

Evaporator

The 2-pass dual circuit shell and tube type direct expansion (DX) evaporator has refrigerant in the tubes and chilled liquid flowing through the baffled shell. The waterside (shell) design working pressure of the cooler is 10.3 bar g. The refrigerant side (tubes) design working pressure is 27.58 bar g. The refrigerant side is protected by pressure relief valve(s).

The evaporator shall have water pass baffles fabricated from galvanised steel to resist corrosion. Removable heads are provided for access to internally enhanced, seamless, copper tubes. Water vent and drain connections are included. The cooler is insulated with flexible closed-cell foam.

Water Connection to the evaporator is via victaulic-grooved connections. Flange connections are available as an option.

Condenser (YCWL units only)

The twin-refrigerant circuit water-cooled condenser is cleanable shell and tubes type with seamless externally finned copper tubes rolled into tubes sheets, removable water heads and built-in subcooler. The waterside (tubes) design working pressure is 10 bar g. The refrigerant side (shell) design working pressure is 38.61 bar g. The refrigerant side is protected by pressure relief valve(s).

Water Connection to the condenser is via victaulic-grooved connections. Flange connections are available as an option.

Power and Control Panels

All power and controls are contained in a IP32 cabinet with hinged, latched and gasket sealed outer doors.

The power panel includes:

- A factory mounted non-fused disconnect switch with external, lockable handle to enable connection of the unit power supply. The disconnect switch can be used to isolate the power for servicing.
- Factory mounted compressor contactors and manual motor starters to provide overload and short circuit protection.
- Factory mounted control transformer to convert the unit supply voltage to 110 V - 1 Ø - 50 Hz for the control system.
- Control supply fuses and connections for a remote emergency stop device.

The control panel includes:

- A Liquid Crystal Display (two display lines of twenty characters per line) with Light Emitting Diode backlighting for easy viewing.
- A Colour coded 12-button keypad.
- Customer terminal block for control inputs and liquid flow switch.

The microprocessor control includes:

- Automatic control of compressor start/stop, anti-coincidence and anti-recycle timers, automatic pumpdown on shutdown, evaporator pump and unit alarm contacts. Automatic reset to normal chiller operation after power failure.
- Remote water temperature reset via a pulse width modulated (PWM) input signal or up to two steps of demand (load) limiting
- Software is loaded into the microprocessor controller via a SD card, with programmed setpoints retained in a lithium battery backed real time clock (RTC) memory.
- Forty character liquid crystal display, with description available in five languages (English, French, German, Spanish or Italian)

Programmable setpoints:

- Chilled liquid temperature setpoint and range
- Remote reset temperature range
- Set daily schedule/holiday for start/stop
- Manual override for servicing
- Low liquid temperature cutout
- Low suction pressure cutout
- High discharge pressure cutout
- Anti-recycle timer (compressor start cycle time)
- Anti-coincident timer (delay compressor starts)

Displayed Data:

- Return and leaving liquid temperature
- Low leaving liquid temperature cutout setting
- Metric or Imperial data
- Discharge and suction pressure cutout settings
- System discharge and suction pressures
- Anti-recycle timer status for each compressor
- Anti-coincident system start timer condition
- Compressor run status
- No cooling load condition

- Day, date and time
- Daily start/stop times
- Holiday status
- Automatic or manual system lead/lag control
- Lead system definition
- Compressor starts & operating hours (each compressor)
- Run permissive status
- Number of compressors running
- Liquid solenoid valve status
- Load & unload timer status
- Water pump status

System Safeties:

Cause individual compressors to perform auto shut down and require manual reset in the event of 3 trips in a 90-minute time period:

- High discharge pressure
- Low suction pressure
- High pressure switches
- Motor protector
- Unit Safeties:
 - Are automatic reset and cause compressor to shut down
 - Low leaving chilled liquid temperature
 - Under voltage
 - Loss of liquid flow (through flow switch)

Alarm Contacts:

- Low leaving chilled liquid temperature
- Low voltage
- Low battery
- High discharge pressure (per system)
- Low suction pressure (per system)

ACCESSORIES AND OPTIONS

Soft Starters

Factory mounted soft starters reduce the inrush current to the last compressor on each refrigerant circuit. They are preset so that no field adjustment is required.

Power Factor Correction

Factory mounted passive (static) power factor correction capacitors to correct unit compressor power factors to a target of 0.9 (depending on operating conditions).

Language LCD and Keypad

English, French, German, Italian and Spanish unit LCD read-out and keypad available. Standard language is English.

Non-reversible Heat Pump

Allows the chiller to control the leaving condenser liquid temperature (LCLT). The unit will load and unload to maintain fixed LCLT.

38 mm Evaporator Insulation

Double thickness insulation provided for enhanced efficiency, and low temperature applications.

Dual Pressure Relief Valves

Two pressure relief valves mounted on a 3-way valve in parallel of which one is operational and the other one assist during maintenance.

Suction Service Valves

A ball valve is added to each suction line pipework for isolation.

Victaulic Flange Kit

Victaulic PN10 Flange joint kit supplied loose for field installation. Includes flange and companion flange and all necessary nuts, bolts and gaskets.

Compressor Acoustic Blankets

Each compressor is individually enclosed in an acoustic sound blanket. The sound blankets are made with one layer of acoustical absorbent textile fibre of 15 mm thickness and one layer of anti vibrating heavy material thickness of 3 mm. Both are closed by two sheets of welded PVC, reinforced for temperature and UV resistance.

Flow switch

Vapour Proof, paddle-type, 10.3 barg DWP, -29°C to 121°C with 1" NPT connection for upright mounting in horizontal pipe. This flow switch or its equivalent must be supplied with each unit to protect vessels from loss of liquid flow (Field Mounted)

Differential Pressure Switch

Alternative to the paddle type flow switch. 0-3 bar range with ¼" NPTE pressure connections (field mounted).

Neoprene Pad Isolators

Recommended for normal installations (field mounted).

25 mm Spring Isolators

Level adjustable, spring and cage type isolators for mounting under the unit base rails (field mounted).

Electronic Expansion Valve

Factory fitted Electronic Expansion Valve to provide a flexible and reliable range of operation from brine to comfort cooling conditions. Mandatory option for application below -1°C chilled water temperature.

REFRIGERANT FLOW DIAGRAM YCWL

Low-pressure liquid refrigerant enters the cooler tubes and is evaporated and superheated by the heat energy absorbed from the chilled liquid passing through the cooler shell. Low-pressure vapour enters the compressors where pressure and superheat are increased. High pressure superheated refrigerant enters the condenser shell where heat is rejected to the condenser water passing through the tubes. The fully condensed and subcooled liquid leaves the condenser and enters the expansion valve, where pressure reduction and further cooling takes place. The low-pressure liquid refrigerant then returns to the cooler.

YCRL

Low-pressure liquid refrigerant enters the cooler tubes and is evaporated and superheated by the heat energy absorbed from the chilled liquid passing through the cooler shell. Low-pressure vapour enters the compressor where pressure and superheat are increased. The high pressure superheat refrigerant enters the remote air cooled condenser where heat is rejected via the condenser coil & fans. The fully condensed and subcooled liquid leaves the remote air cooled condenser and enters the expansion valve, where pressure reduction and further cooling takes place. The low-pressure liquid refrigerant then returns to the cooler.

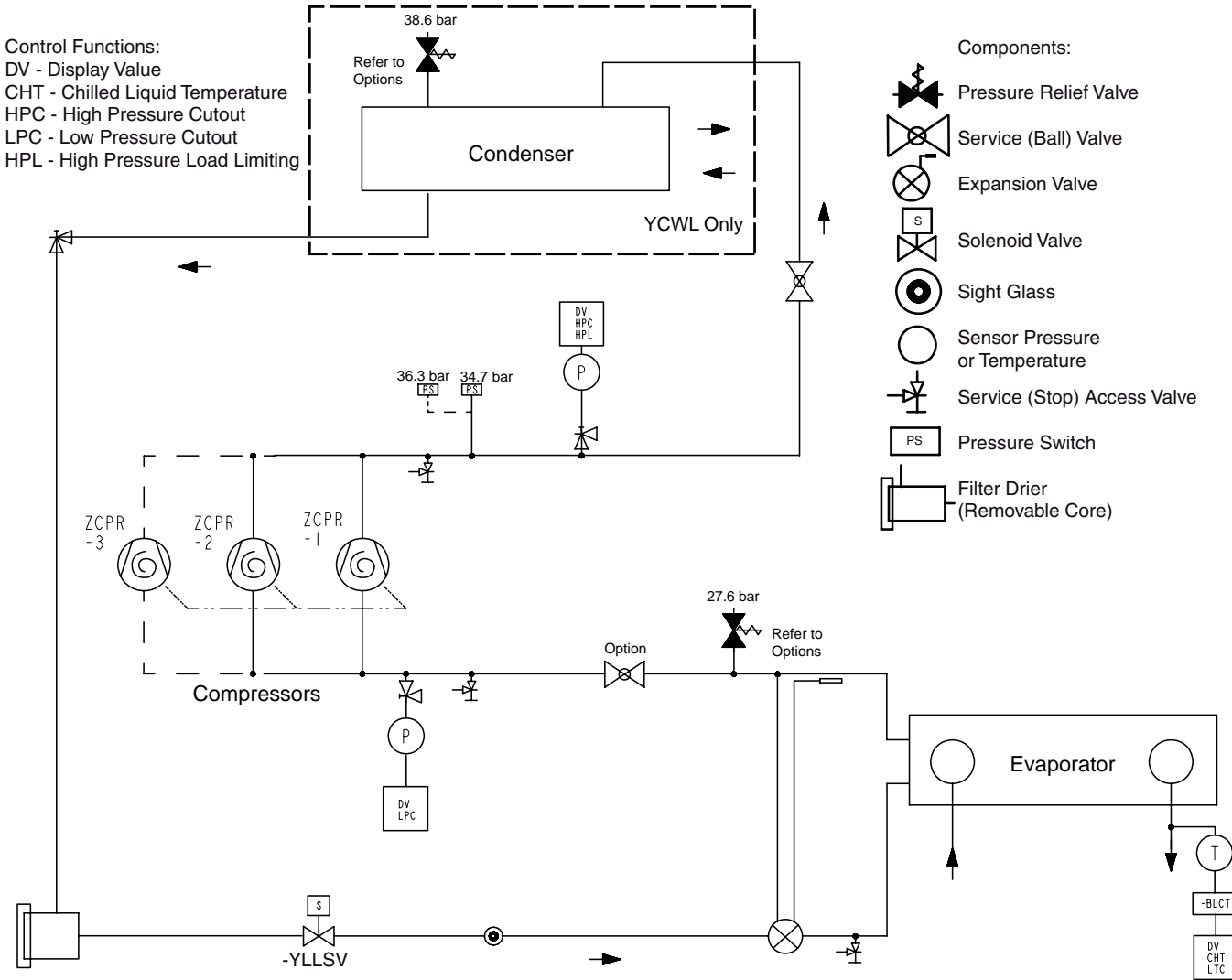

UNIT MODEL NUMBER NOMENCLATURE

NOMENCLATURE

The model number denotes the following characteristics of the unit.

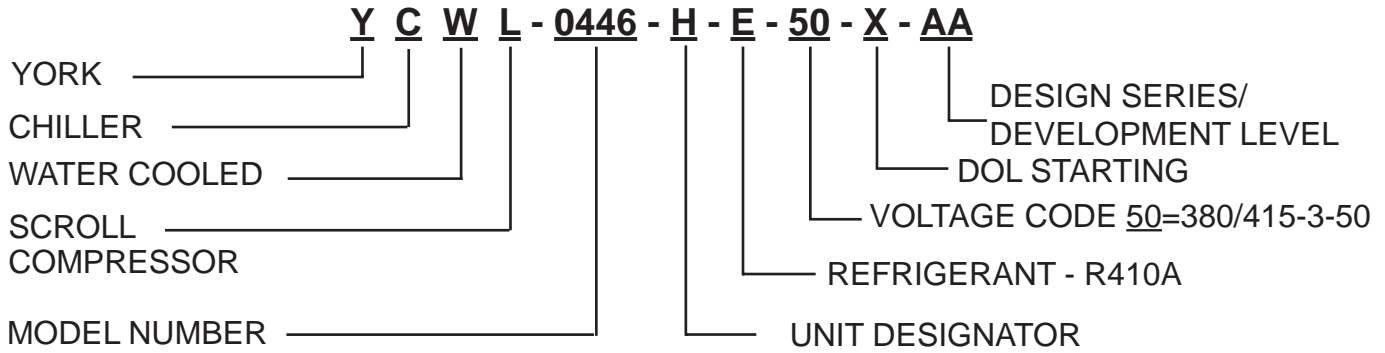

UNIT DESIGNATOR

S - Standard Efficiency

H - High Efficiency

HANDLING AND STORAGE

DELIVERY AND STORAGE

To ensure consistent quality and maximum reliability, all units are tested and inspected before leaving the factory. Units are shipped completely assembled and containing refrigerant under pressure. Units are shipped without export crating unless crating has been specified on the Sales Order.

If the unit is to be put into storage, prior to installation, the following precautions should be observed:

- Ensure that all openings, such as water connections, are securely capped.
- Do not store where exposed to ambient air temperatures exceeding 46°C.
- The unit should be stored in a location where there is minimal activity in order to limit the risk of accidental physical damage.
- To prevent inadvertent operation of the pressure relief devices the unit must not be steam cleaned.
- It is recommended that the unit is periodically inspected during storage.

INSPECTION

Remove any transit packing and inspect the unit to ensure that all components have been delivered and that no damage has occurred during transit. If any damage is evident, it should be noted on the carrier's freight bill and a claim entered in accordance with the instructions given on the advice note.

Major damage must be reported immediately to your local Johnson Controls representative.

MOVING THE CHILLER

Prior to moving the unit, ensure that the installation site is suitable for installing the unit and is easily capable of supporting the weight of the unit and all associated services.

The units are designed to be lifted using lifting chains.

Lifting by Crane/Hoist

Attach the lifting chains to the lifting lugs on each corner of the unit framework. A spreader frame should be used to prevent damage to the unit from the lifting chains.

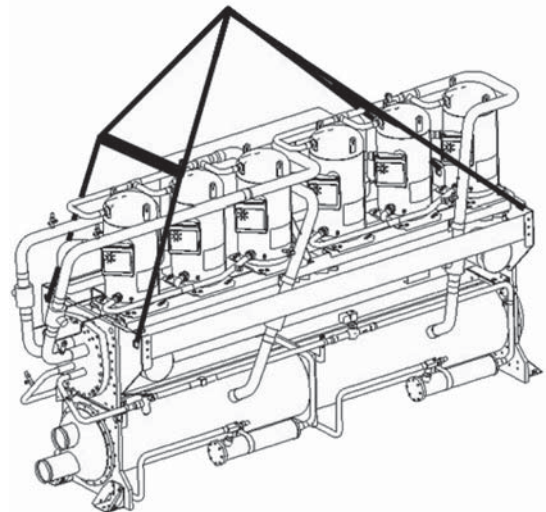

The unit must only be lifted at the points provided.

LIFTING WEIGHTS

For details of weights and weight distribution refer to the Technical Data, Section 6.

This Page Left Intentionally Blank

INSTALLATION

Location Requirements

To achieve optimum performance and trouble-free service, it is essential that the proposed installation site meet with the location and space requirements for the model being installed.

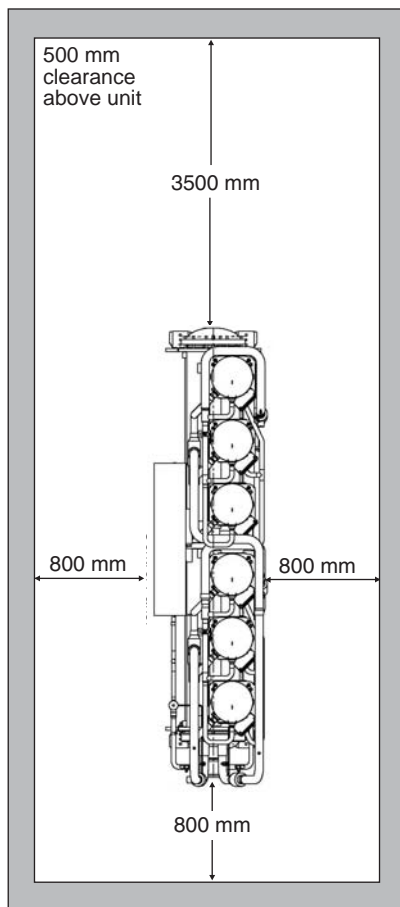

The clearances recommended are nominal for the safe operation and maintenance of the unit and power and control panels. Local health and safety regulations, or practical considerations for service replacement of large components, may require larger clearances than those given in this manual.

Units are designed for indoor installation and not intended for wet, corrosive or explosive atmospheres. Installation should allow for water drain, ventilation and sufficient clearance for service, including tube cleaning/removal.

For installation in equipment rooms near noise-critical areas, common walls should be of adequate sound attenuating construction, all doors should be tightly gasketed, and the unit should have vibration isolators fitted.

The concrete base must be capable of supporting 150% of the operating weight. In case of upper floors, the unit and piping should be isolated from walls and ceiling. The unit may be bolted to the foundation using XX mm \varnothing holes. When lower transmitted vibration levels are required optional anti-vibration isolators can be supplied loose for site installation.

Installation of Vibration Isolators

An optional set of spring type vibration isolators can be supplied loose with each unit.

Pipework Connection

The following piping recommendations are intended to ensure satisfactory operation of the unit. Failure to follow these recommendations could cause damage to the unit, or loss of performance, and may invalidate the warranty.



The maximum flow rate and pressure drop for the cooler and condenser must not be exceeded at any time.

The water must enter the heat exchangers by the inlet connection.

A flow switch must be installed in the customer pipework at the outlet of the exchangers as shown in the arrangement diagrams, and wired back to the control panel using screened cable. This is to prevent damage to the exchangers caused by inadequate liquid flow.

The liquid pumps installed in the pipework systems should discharge directly into the unit heat exchanger sections of the system. The pumps require an auto-starter (by others) to be wired to the control panel.

Pipework and fittings must be separately supported to prevent any loading on the heat exchangers. Flexible connections are recommended which will also minimize transmission of vibrations to the building. Flexible connections must be used if the unit is mounted on anti-vibration mounts as some movement of the unit can be expected in normal operation.

Pipework and fittings immediately next to the heat exchangers should be readily de-mountable to enable cleaning prior to operation, and to facilitate visual inspection of the exchanger nozzles.

Each heat exchanger must be protected by a strainer, preferably of 20 microns, fitted as close as possible to the liquid inlet connection, and provided with a means of local isolation.

The heat exchangers must not be exposed to flushing velocities or debris released during flushing. It is recommended that a suitably sized by-pass and valve arrangement be installed to allow flushing of the pipework system. The by-pass can be used during maintenance to isolate the heat exchanger without disrupting flow to other units.

Thermometer and pressure gauge connections should be provided on the inlet and outlet connections of each heat exchanger.

Drain and air vent connections should be provided at all low and high points in the pipework to permit drainage of the system, and to vent any air in the pipes.

Liquid systems at risk of freezing, due to low ambient temperatures, should be protected using insulation and heater tape and/or a suitable glycol solution. The liquid pumps must also be used to ensure liquid is circulated when the ambient temperature approaches freezing point. Insulation should also be installed around the heat exchanger nozzles.

Water Treatment

The unit performance given in the Design Guide is based on a fouling factor of 0.044 m² °C/kW. Dirt, scale, grease and certain types of water treatment will adversely affect the heat exchanger surfaces and therefore unit performance. Foreign matter in the water system(s) can increase the heat exchanger pressure drop, reducing the flow rate and causing potential damage to the heat exchanger tubes.

Aerated, brackish or salt water is not recommended for use in the water systems. Johnson Controls recommends that a water treatment specialist be consulted to determine that the proposed water composition will not affect the evaporator materials of carbon steel and copper. The pH value of the water flowing through the heat exchangers must be kept between 7 and 8.5.

For unit operation with chilled liquid temperatures leaving the cooler at below 4.5°C, glycol solutions should be used to help prevent freezing. This manual gives recommended solution strength with water, as a percentage by weight, for the most common types of glycol. It is important to check glycol concentration regularly to ensure adequate concentration and avoid possible freeze-up in the cooler.

PIPEWORK ARRANGEMENT







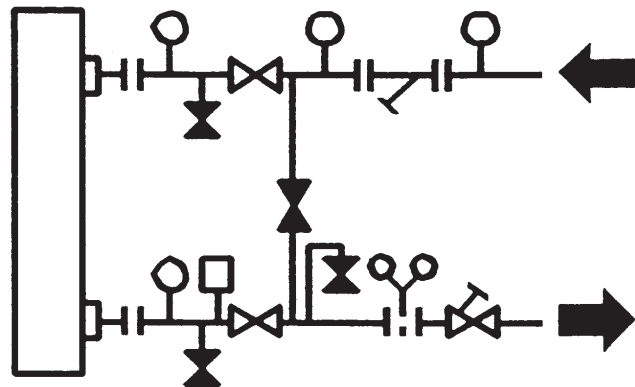

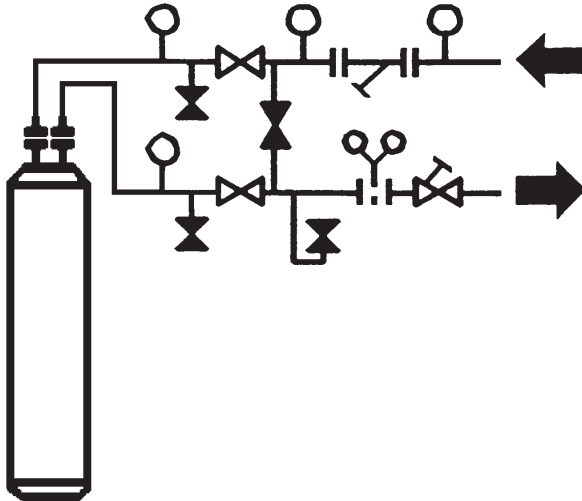
The following are suggested pipework arrangements for single unit installations. For multiple unit installations, each unit should be piped as shown.

Recommendations of the Building Services Research Association

Chilled Liquid System



Condenser Cooling Liquid System

-  -Isolating Valve - Normally Open
-  -Isolating Valve - Normally Closed
-  -Flow Regulating Valve
-  -Flow Measurement Device
-  -Strainer
-  -Pressure Tapping
-  -Flow Switch
-  -Victualic/Flanged Connection
-  -Pipework

Connection Types & Sizes

For connection sizes relevant to individual models refer to the physical data tables in this manual

Refrigerant Relief Valve Piping

The compressor, cooler and condensers are each protected against internal refrigerant over-pressure and fire by refrigerant relief valves. The pressure relief valve is set at the design pressure of the system and has discharge capacity required by the relevant standard.

It is recommended that each valve should be piped to the exterior of the building so that when the valve is activated the release of high pressure gas and liquid cannot be a danger or cause injury.

The size of any pipework attached to a relief valve must be of sufficient diameter so as not to cause resistance to the operation of the valve. For critical or complex installations refer to EN13136.

Unless otherwise specified by local regulations, the internal diameter depends on the length of pipe required and can be estimated with the following formula:

$$D^5 = 1.447 \times L$$

Where:

D = minimum pipe internal diameter (cm)

L = length of pipe (m).

If relief pipework is common to more than one valve its cross sectional area must be at least the total required by each valve. Valve types should not be mixed on a common pipe. Precautions should be taken to ensure that the exit of relief valves/vent pipe remain clear of obstructions at all times.

Condenser Cooling Liquid Systems

For primary cooling of units, condensers are usually piped in conjunction with a cooling tower or a dry cooler, although in some cases they can be cooled by well water.

With liquid cooled units it is necessary to control coolant flow and / or temperature into the condenser to maintain refrigerant pressure as constant as possible to ensure satisfactory operation of the expansion valves.

Direct Pressure Control (by others)

With YCWL units it is possible, if desired, to control the condenser cooling liquid inlet temperature / flow directly from the unit refrigerant pressure.

The refrigerant pressure can either be used to control cooling tower / dry cooler effectiveness by controlling fans or dampers on the tower, or to control condenser flow using a three way bypass valve.

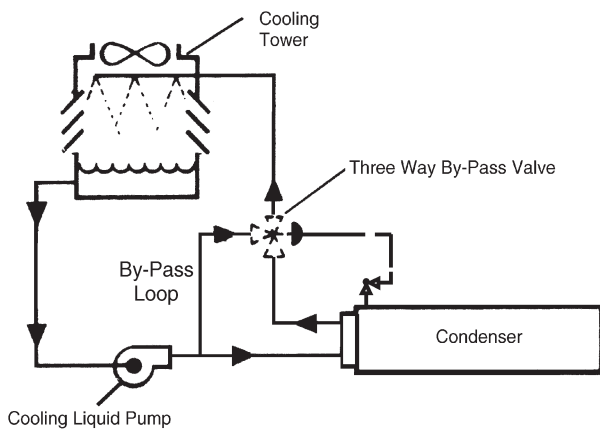

The aim is to maintain a stable discharge pressure as low as possible, but at least 4.8 bar above suction pressure. This can be done at a fixed value above the highest expected suction pressure, or by also measuring suction pressure and using differential control. In either case condenser cooling liquid flow and temperature limits must also be observed.

Inlet Temperature Control (by others)

For a cooling tower / dry cooler system, the simplest forms of control are to use fan cycling, fan speed control, or air damper control, with the tower having a thermostat in its sump. This will ensure stable condenser cooling liquid temperature sensing at design conditions and should be adjusted to ensure a condenser cooling liquid entering temperature of not lower than 18°C at lower ambient conditions.

If these methods are not available, or a cooling tower is not the source of cooling water, then a three way valve recirculation system can be used with control based on condenser inlet liquid temperature. In this case the objective is to maintain the inlet cooling liquid temperature as low as possible, although still observing the minimum limit of 18°C.

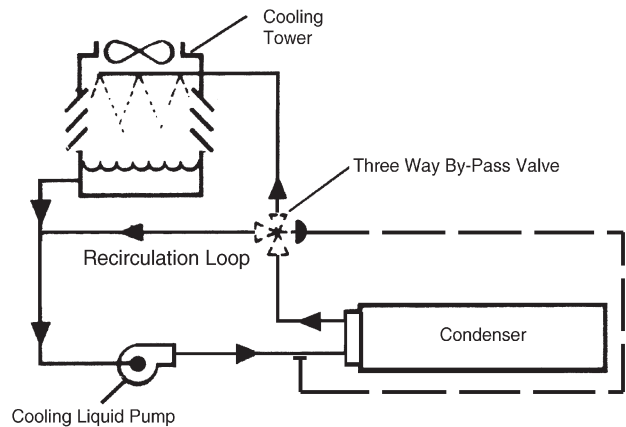

CONDENSERLESS UNIT REFRIGERANT PIPING

General

When the unit has been located in its final position, the unit piping may be connected. Normal installation precautions should be observed in order to receive maximum operating efficiencies. All piping design and installation is the responsibility of the user.

JOHNSON CONTROLS ASSUMES NO WARRANTY RESPONSIBILITY FOR SYSTEM OPERATION OR FAILURES DUE TO IMPROPER PIPING OR PIPING DESIGN.

All filter driers, sight glasses, expansion valves and liquid line solenoid valves are factory installed on each refrigerant circuit. Interconnecting refrigerant piping and refrigerant charge are supplied and installed by others.

Refrigerant Line Sizing

Refrigerant piping systems must be designed to provide practical line sizes without excessive pressure drops, prevent compressor oil from being “trapped” in the refrigerant piping, and ensure proper flow of liquid refrigerant to the thermal expansion valve. Considerations should be given to:

- 1) Discharge line pressure drop due to refrigerant flow.
- 2) Discharge line refrigerant velocity for oil return.
- 3) Liquid line pressure drop due to refrigerant flow.
- 4) Liquid line pressure drop (or gain) due to vertical rise of the liquid line.

To ensure a solid column of liquid refrigerant to the expansion valve, the total liquid line pressure drop should never exceed 275 kPa. Refrigerant vapour in the liquid line will measurably reduce valve capacity and poor system performance can be expected.

To allow adequate oil return to the compressor, discharge risers should be sized for a minimum of 5.1 m/s while the system is operating at minimum capacity to ensure oil return up the suction riser.

Chiller Below Condenser

On a system where the chiller is located below the condenser, the discharge line must be sized for both pressure drop and oil return. In some cases a double discharge riser must be installed to ensure reliable oil return at reduced loads.

Condenser Below Chiller

When the condenser is located below the chiller, the liquid line must be designed for both friction loss and static head loss due the vertical rise. The value of static head loss of 11.3 kPa/m must be added to the friction loss pressure drop in addition to all pressure drops due to driers, valves, etc.

Oil traps

All horizontal discharge lines should be pitched at least 2 cm/m in the direction of the refrigerant flow to aid in the return of oil to the chiller. All discharge lines with a vertical rise exceeding 90 cm should have a “P” trap at the bottom and top of the riser. Discharge lines with a vertical rise exceeding 7.5 m should be trapped every 4.5 m.

Refrigerant Charge

The chiller is charged and shipped with a dry nitrogen holding charge. The operating charge for the chiller, remote condenser and refrigerant piping must be weighed in after all refrigerant piping is installed, leak checked, and evacuated. Final adjustment of refrigerant charge should be verified by subcooling values (refer to IOM section on Pre-Startup for checking subcooling).

ELECTRICAL CONNECTION

The following connection recommendations are intended to ensure safe and satisfactory operation of the unit. Failure to follow these recommendations could cause harm to persons, or damage to the unit, and may invalidate the warranty.

No additional controls (relays, etc.) should be mounted in the control panel. Power and control wiring not connected to the control panel should not be run through the control panel. If these precautions are not followed it could lead to a risk of electrocution. In addition, electrical noise could cause malfunctions or damage the unit and its controls.

Power Wiring

These units are suitable for 380 or 400 V, 3 phase, 50 Hz nominal supplies only.

All electrical wiring should be carried out in accordance with local regulations. Route properly sized cables to the cable entries in the top of the power panel.

In accordance with EN 60204 it is the responsibility of the user to install over current protection devices between the supply conductors and the power supply terminals on the unit.

To ensure that no eddy currents are set up in the power panel, the cables forming each 3 phase power supply must enter via the same cable entry.

All sources of supply to the unit must be taken via a common point of isolation (not supplied by Johnson Controls).

Single Point Power Supply Wiring

All models require one field provided 400 V, 3Ø, 50 Hz + PE (Protected Earth) supply to the unit with circuit protection.

Connect the 3 phase supply to the non-fused disconnect switch located in the power panel using M10 lugs

Connect the earth wire to the main protective earth terminal located in the power panel.

Remote Emergency Stop Device

If required, a remote emergency stop device may be wired into the unit. This device should be rated at 16 amps, 110 V, AC-15. The device should be wired into terminals L and 5 in the power panel after removing the factory fitted link.

Control Wiring - Voltage Free Contacts

All wiring to the voltage free contact terminal block requires a supply provided by the customer maximum voltage 254 Vac, 28 Vdc.

The customer must take particular care deriving the supplies for the voltage free terminals with regard to a common point of isolation. Thus, these circuits when used must be fed via the common point of isolation so the voltage to these circuits is removed when the common point of isolation to the unit is opened. This common point of isolation is not supplied by Johnson Controls.

In accordance with EN 60204 it is recommended that the customer wiring to these terminals uses orange wires. This will ensure that circuits not switched off by the units supply disconnecting device are distinguished by colour, so that they can easily be identified as live even when the unit disconnecting devices are off. The Johnson Controls voltage free contacts are rated at 125 VA.

All inductive devices (relays) switched by the Johnson Controls voltage free contacts must have their coil suppressed using standard RC suppressors. If these precautions are not followed, electrical noise could cause malfunctions or damage to the unit and its controls.

Chilled Liquid Pump Starter

Terminals 23 and 24 close to start the liquid pump. This contact is closed if there is a 'Leaving Liquid

Temperature Cutout' or any of the compressors are running or the daily schedule is not calling for a shutdown with the unit switch on.

The contact must be used to ensure that the pump is running in the event of a 'Leaving Liquid Temperature Cutout'.

The pump contact will not close to run the pump if the unit has been powered up for less than 30 seconds, or if the pump has run in the last 30 seconds, to prevent pump motor overheating.

Run Contacts

Terminals 25 and 26 close to indicate that refrigerant system 1 is running and terminals 27 and 28 close to indicate that refrigerant system 2 is running.

Alarm Contacts

Each refrigerant system has a voltage-free normally open contact that will close when control power is applied to the panel, if no fault conditions are present. When a fault occurs which locks a system out, or there is a power failure the contact opens. To obtain a system alarm signal, connect the alarm circuit to terminals 29 and 30 for No. 1 system and terminals 31 and 32 for No. 2 system.

Control Wiring - System Inputs

All wiring to the control terminal block (nominal 30 Vdc) must be run in screened cable, with the screen earthed at the panel end only. Run screened cable separately from mains cable to avoid electrical noise pick-up.

The voltage free contacts must be suitable for 30 Vdc (gold contacts recommended). If the voltage free contacts form part of a relay or contactor, the coil of the device must be suppressed using a standard RC suppressor. The above precautions must be taken to avoid electrical noise which could cause a malfunction or damage to the unit and its controls.

Flow Switch

A chilled liquid flow switch of suitable type must be connected to terminals 13 and 14 to provide adequate protection against loss of liquid flow.

Remote Start/Stop

Connect a remote switch to terminals 13 and 51 to provide remote start/stop control if required.

Remote Reset of Chilled Liquid Setpoint

The PWM input (terminals 13 and 20) allows reset of the chilled liquid setpoint by supplying a 'timed' contact closure. Refer to Section 6 for details.

Remote Load Limiting

Load limiting prevents the unit from loading beyond a desired value. The unit % load limit depends on the number of compressors on the unit. The load limit inputs to terminals 13 and 21 work in conjunction with the PWM input to terminals 13 and 20.

Heat Pump Kit

When the special quotation Non-reversible Heat Pump Option is fitted the heat pump mode is selected by closing a voltage free contact between terminals 13 and 50.

EMS Analogue Input

Provides a means of resetting the leaving chilled liquid temperature from the BAS/EMS. Accepts 4 to 20 mA, 0 to 20 mA, 0 to 10 Vdc or 2-10 Vdc. Connect to terminal A+ and A-. Disabled when using Modbus or BACnet MS/TP communications.

Modbus and BACnet MS/TP

Enable communications with building protocol systems using Modbus or BACnet protocol. Connect through standard RS485 port. Disabled when using EMS Analogue Input.

CONNECTION DIAGRAM

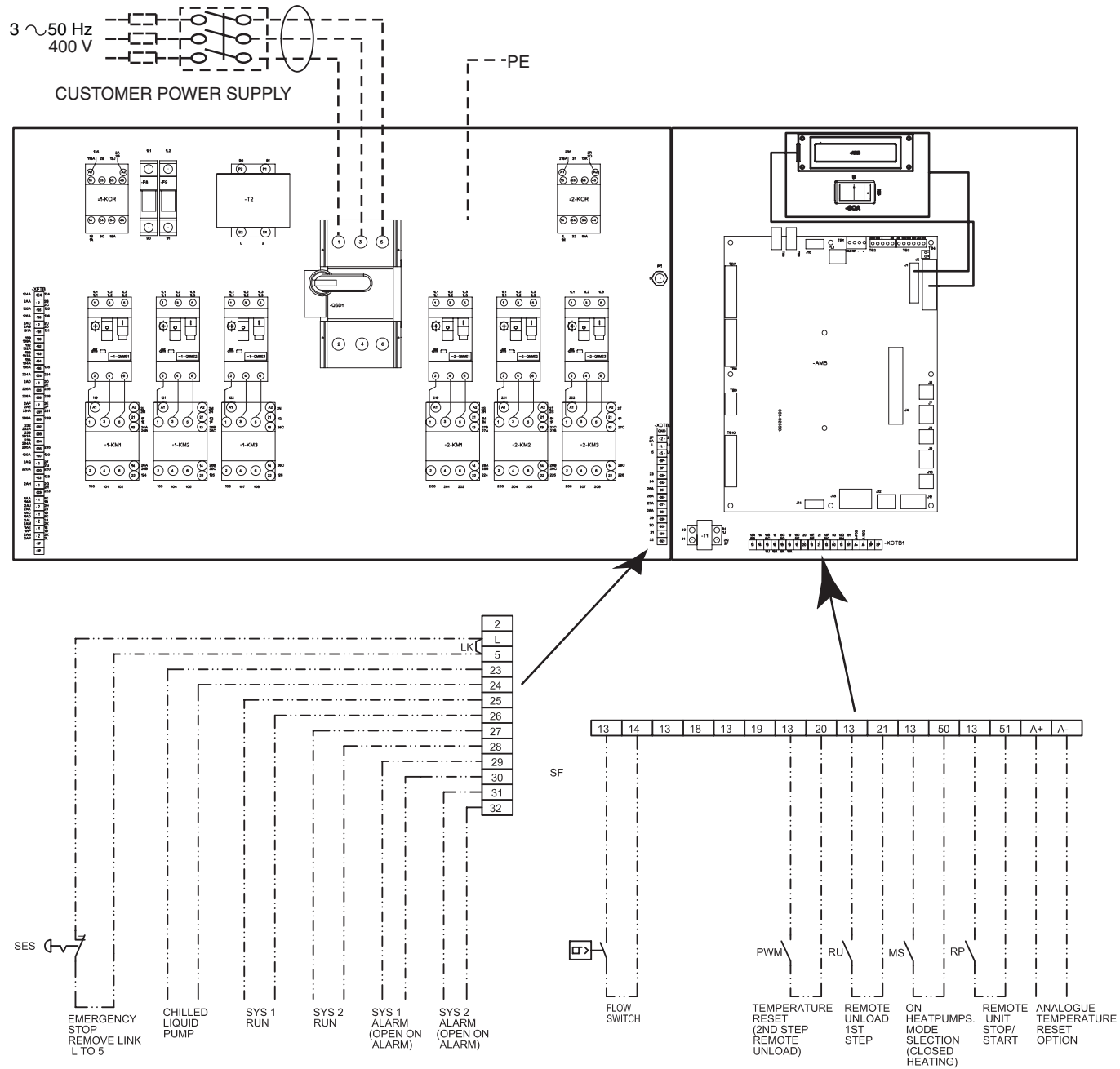

COMMISSIONING

PREPARATION



Commissioning of this unit should only be carried out by Johnson Controls Authorised personnel.

The unit On/Off switch on the front of the control panel has been set to the Off position at the factory. This switch must remain in the Off position, preventing running of the unit until commissioned by Authorised personnel. If the switch has been set to the On position before commissioning then it must be reported to Johnson Controls otherwise the warranty may be invalidated.

Preparation - Power Off

The following checks should be made with the customer supply/supplies to the unit switched OFF.

Inspection: Inspect unit for installation damage. If found take action and/or repair as appropriate.

Refrigerant charge: Units are normally shipped as standard with a full refrigerant operating charge. Check that refrigerant pressure is present in both systems and that no leaks are apparent. If no pressure is present a leak test must be undertaken, the leak(s) located and repaired. Repaired systems must be evacuated with a suitable vacuum pump/recovery unit as appropriate to below 100 microns before charging.

Do not charge liquid refrigerant with static water in the evaporator. Care must also be taken to charge liquid refrigerant slowly to avoid excessive thermal stress at the charging point.

Once the vacuum is broken, charge with the full operating charge as given in Section 9.

Liquid sub-cooling measured at the liquid line should be between 8.5 and 11.0 °C at circuit full load. Sub-cooling is determined by the level of refrigerant charge in each system.

Valves: Ensure that the compressor discharge and suction service valves are set correctly (OPEN).

Compressor oil: The oil level in multiple scroll compressors (piped in parallel) must be checked directly after all compressors are shut down and have been allowed time to stabilise.

The oil level must be between the bottom and middle of the oil sight glass mounted in the oil equalising line between the compressors.

Isolation/protection: Verify that all sources of electrical supply to the unit are taken from a point of isolation.

Control panel: Check the panel to see that it is free of foreign materials (wire, metal chips, etc.) and clean out if required.

Power connections: Check the customer power cables are connected correctly. Ensure that connections of power cables within the power panel to the non-fused switch disconnects are tight.

Earthing: Verify that the unit earth terminal is properly connected to a suitable earthing point. Ensure that all unit internal earth connections are tight.

Compressor Overload Settings: Check the factory setting of the Compressor Motor Starters as follows:

	SYS 1	SYS 2
YCWL0240SE	31.2	31.2
YCWL0291SE	35.9	35.9
YCWL0346SE	51.6	35.9
YCWL0395SE	51.6	51.6
YCWL/YCRL0200HE	23.8	23.8
YCWL/YCRL0230HE	31.2	23.8
YCWL/YCRL0260HE	31.2	31.2
YCWL0301HE/YCRL0300HE	35.9	35.9
YCWL0346HE/YCRL0345HE	51.6	35.9
YCWL/YCRL0385HE	31.2	31.2
YCWL0425HE	51.6	51.6
YCWL0446HE/YCRL0445HE	35.9	35.9
YCWL0531HE/YCRL0530HE	51.6	35.9
YCWL/YCRL0610HE	51.6	51.6

Supply voltage: Verify that the site voltage supply corresponds to the unit requirement and is within the limits given in the Technical Data, Section 6. The phase imbalance should be less than 2% of the average voltage.

Soft Start (Option)

Due to vibration during transport the soft starter internal bypass contactor may be in a undefined state. If the following procedure is not followed this may result in the compressor momentarily starting when the unit power is first turned on.

IMPORTANT

During commissioning or if the soft start is replaced the following procedure **MUST BE PERFORMED**.

1. With the unit switch and unit switch disconnect set to OFF to isolate the unit, remove the fuses from the compressors fitted with a soft starter.
2. Turn ON the unit switch disconnect to turn on the unit supply and thus apply control circuit voltage to soft starter terminals A1 and A2.
3. Turn OFF the unit disconnect switch and refit the compressor fuses.

Switch Settings: Ensure that the unit On/Off toggle switch on the control panel is set to OFF. Set the non-fused disconnect switch to ON. The customers disconnection devices can now be set to ON.

THE MACHINE IS NOW LIVE!

Crankcase Heaters: Verify the heaters are energised.

Depending upon the ambient temperature the crankcase heaters must be on for 12 to 24 hours before start-up.

Water System: Verify that the chilled liquid system has been installed correctly, and has been commissioned with the correct direction of water flow through the evaporator. Inlet should be at the refrigerant pipework connection end of the evaporator. Purge air from the evaporator using the air vent mounted in the pipework.

Verify that the cooling liquid system has been installed correctly, and has been commissioned with the correct direction of water flow through the condenser. Purge air from the evaporator using the air vent mounted in the pipework.

Flow rates and pressure drops must be within the limits given in the Technical Data, Section 6. Operation outside of these limits is undesirable and could cause damage.

Flow switch: Verify a chilled liquid flow switch is correctly fitted in the customer's pipework on the cooler outlet, and wired into the control panel correctly.

Temperature sensor(s): Ensure the leaving (-BLCT) liquid temperature sensor is coated with heat conductive compound (Part No. 013-00890-000) and are inserted in the water inlet and outlet sensor pockets of the cooler.

Control supply: Verify the control panel display is illuminated.

HP cut-out reset: Check that the hand reset mechanical high pressure cut-outs mounted on the discharge lines are at the correct setting and are reset.

Programmed options: Verify that the options factory programmed into the Microprocessor Control Centre are in accordance with the customers order requirements by pressing the 'OPTIONS' key on the keypad and reading the settings from the display. Refer also to the MBCS Manual for notes and explanation of messages.

Programmed settings: Ensure the system cut-out and operational settings are in accordance with operational requirements by pressing the 'PROGRAM' key (refer to MBCS Manual).

Date & time: Press the 'CLOCK' key and set the date and time (refer to MBCS Manual).

Start/Stop schedule: Programme the daily and holiday start/stop by pressing the 'SCHEDULE/ADVANCE DAY' key (refer to MBCS Manual).

Setpoints: Set the required leaving chilled liquid temperature set-point and control range using the 'COOLING SETPOINTS' key (refer to MBCS Manual).

Compressor Operation: Use the 'OPTIONS' key to switch off each refrigerant system in turn (refer to MBCS Manual) and then check the compressors on the active system:

Connect a manifold gauge to each refrigerant circuit suction and discharge service valves and temporarily start each compressor and check that the discharge pressure rises and the suction pressure decreases to ensure that the compressors are operating in the correct direction. Any faults found must be corrected before starting the unit.

After completing the checks on both circuits, set both systems to on using the 'OPTIONS' key.

FIRST TIME START-UP

During the commissioning period there should be sufficient heat load to run the unit under stable full load operation to enable the unit controls, and system operation to be set up correctly and a commissioning log taken. Read the following section in conjunction with the MBCS Manual, then proceed step by step as follows:

Interlocks: Verify that liquid is flowing through the evaporator and that heat load is present. Ensure that any remote run interlocks are in the run position and that the run schedule requires the unit to run or is overridden.

Start-up: Set the unit switch to the ON position to start the unit (there may be a few seconds delay before the first compressor starts because of the anti-recycle timer). Be ready when each compressor starts, to switch the unit off immediately if any unusual noises or other adverse conditions develop. Refer to the Section 6 for the normal operating sequence from start-up.

Refrigerant flow: When a compressor starts a flow of liquid refrigerant will be seen in the liquid line sight glass. After several minutes operation and providing a full charge of refrigerant is in the system, the bubbles will disappear and be replaced by a solid column of liquid. Check that the moisture indicator is satisfactory (Green).

System Operation: Use the 'OPER DATA' key to check the system pressures and temperatures.

Suction Superheat: Check suction superheat at steady full system load only. It is important that no bubbles show in the liquid line sight glass. Measure suction temperature on the copper line about 150 mm before the compressor suction service valve. Measure suction pressure at the compressor service valve. Superheat should be 5.5°C to 7.0°C relative to the 'dew' temperature.

Thermal Expansion valve (when fitted) adjustment:

The expansion valves are factory set and should not need adjustment. If any superheat values are out of range, however, the expansion valve adjusting screw should be adjusted no more than 1 turn at a time ('in' to increase superheat, 'out' to decrease superheat), allowing at least 10 minutes for the valve to stabilise before rechecking the value of superheat.

Subcooling: Check liquid subcooling at steady full compressor load only. Measure liquid line temperature on the copper line beside the main liquid line service valve. Measure liquid pressure at the liquid line service valve. Subcooling should be 5°C to 7°C relative to the 'bubble' temperature. If subcooling is out of range add or remove refrigerant as required. Do not overcharge the unit.

General operation: After completion of the above checks for System 1 repeat the process for system 2. In addition, check that loading occurs as specified in the Section 6 and that general operation is correct.

This Page Left Intentionally Blank

TECHNICAL DATA

EVAPORATOR PRESSURE DROP GRAPH

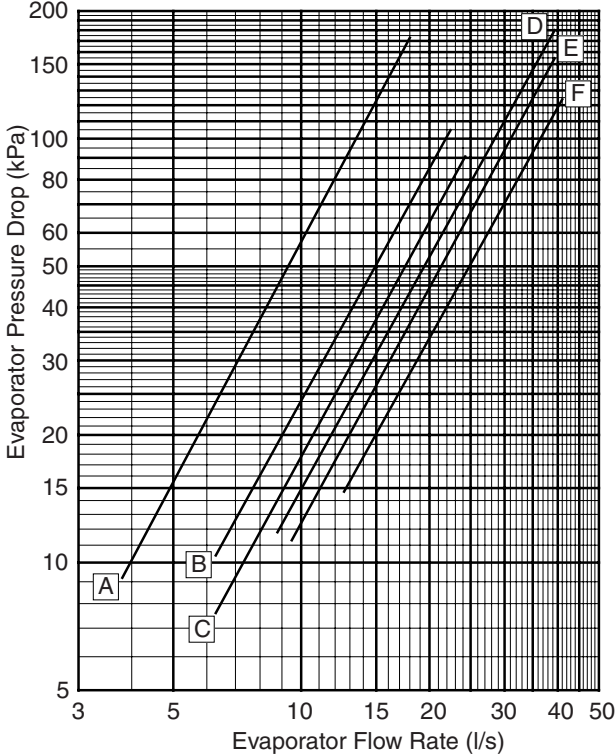

6

PRESSURE DROP FORMULAE

Standard Efficiency (SE) Models	Evaporator Pressure Drop (kPa)	Condenser Pressure Drop (kPa)	Line
YCWL0240SE	$P = 0.7623 \times \text{Flow Rate (l/s)}^{1.8771}$	$P = 0.6822 \times \text{Flow Rate (l/s)}^{1.714}$	A
YCWL0291SE	$P = 0.3651 \times \text{Flow Rate (l/s)}^{1.8204}$	$P = 0.3173 \times \text{Flow Rate (l/s)}^{1.714}$	B
YCWL0346SE	$P = 0.2542 \times \text{Flow Rate (l/s)}^{1.8425}$	$P = 0.3173 \times \text{Flow Rate (l/s)}^{1.714}$	B
YCWL0395SE	$P = 0.2542 \times \text{Flow Rate (l/s)}^{1.8425}$	$P = 0.2165 \times \text{Flow Rate (l/s)}^{1.714}$	C

High Efficiency (HE) Models	Evaporator Pressure Drop (kPa)	Condenser Pressure Drop (kPa) (YCWL Units Only)	Line
YCWL/YCRL0200HE	$P = 0.3651 \times \text{Flow Rate (l/s)}^{1.8204}$	$P = 0.3173 \times \text{Flow Rate (l/s)}^{1.7140}$	B
YCWL/YCRL0230HE	$P = 0.2240 \times \text{Flow Rate (l/s)}^{1.8204}$	$P = 0.3173 \times \text{Flow Rate (l/s)}^{1.7140}$	B
YCWL/YCRL0260HE	$P = 0.2542 \times \text{Flow Rate (l/s)}^{1.8425}$	$P = 0.3173 \times \text{Flow Rate (l/s)}^{1.7140}$	B
YCWL0301HE/YCRL0300HE	$P = 0.2542 \times \text{Flow Rate (l/s)}^{1.8425}$	$P = 0.3173 \times \text{Flow Rate (l/s)}^{1.7140}$	B
YCWL0346HE/YCRL0345HE	$P = 0.2240 \times \text{Flow Rate (l/s)}^{1.8204}$	$P = 0.1470 \times \text{Flow Rate (l/s)}^{1.7140}$	E
YCWL/YCRL0385HE	$P = 0.1844 \times \text{Flow Rate (l/s)}^{1.8320}$	$P = 0.1778 \times \text{Flow Rate (l/s)}^{1.7146}$	D
YCWL0425HE	$P = 0.2240 \times \text{Flow Rate (l/s)}^{1.8204}$	$P = 0.2165 \times \text{Flow Rate (l/s)}^{1.714}$	C
YCWL0446HE/YCRL0445HE	$P = 0.1287 \times \text{Flow Rate (l/s)}^{1.8061}$	$P = 0.1391 \times \text{Flow Rate (l/s)}^{1.7146}$	F
YCWL0531/YCRL0530HE	$P = 0.1287 \times \text{Flow Rate (l/s)}^{1.8061}$	$P = 0.1391 \times \text{Flow Rate (l/s)}^{1.7146}$	F
YCWL/YCRL0610HE	$P = 0.1287 \times \text{Flow Rate (l/s)}^{1.8061}$	$P = 0.1391 \times \text{Flow Rate (l/s)}^{1.7146}$	F

OPERATING LIMITATIONS - YCWL

Standard Efficiency (SE) Models			YCWL0240		YCWL0291		YCWL0346		YCWL0395	
			Min.	Max.	Min.	Max.	Min.	Max.	Min.	Max.
Chilled Liquid	Liquid Outlet Temperature (Water)	°C	4.5 to 15							
	Liquid Outlet Temperature (Glycol)	°C	-7 to 15							
	Liquid Outlet Temperature Range	°C	3 to 8							
	Evaporator Flow Rate	l/s	3.8	18.0	6.3	22.4	6.3	24.3	6.3	24.3
	Evaporator Pressure Drop	kPa	9.2	172.8	10.4	104.8	7.6	90.7	7.6	90.7
Maximum Water Side Pressure	bar	10								
Cooling Liquid	Liquid Outlet Temperature	°C	23 to 50							
	Liquid Outlet Temperature Range	°C	3 to 10							
	Condenser Flow Rate	l/s	5.7	22.7	9.2	28.4	9.2	28.4	11.4	44.2
	Condenser Pressure Drop	kPa	13.4	144.0	14.1	98.2	14.1	98.2	13.9	142.9
	Maximum Water Side Pressure	bar	10							
Maximum Refrigerant Side Pressure	bar	38.6								
Power Supply Voltage 400V, 3 ~, 50 Hz (nominal)	V	360 to 440								
Recommended Minimum System Water Volume	litres	749		901		1063		1218		
Minimum Ambient Air Temperature	°C	4.5								
Maximum Ambient Air Temperature	°C	46								

High Efficiency (HE) Models			YCWL0200		YCWL0230		YCWL0260		YCWL0301		YCWL0346	
			Min.	Max.	Min.	Max.	Min.	Max.	Min.	Max.	Min.	Max.
Chilled Liquid	Liquid Outlet Temperature (Water)	°C	4.5 to 15									
	Liquid Outlet Temperature (Glycol)	°C	-7 to 15									
	Liquid Outlet Temperature Range	°C	3 to 8									
	Evaporator Flow Rate	l/s	6.3	22.4	8.8	39.4	6.3	24.3	6.3	24.3	8.8	39.4
	Evaporator Pressure Drop	kPa	10.4	104.8	11.8	180.0	7.6	90.7	7.6	90.7	11.8	180.0
Maximum Water Side Pressure	bar	10										
Cooling Liquid	Liquid Outlet Temperature	°C	23 to 50									
	Liquid Outlet Temperature Range	°C	3 to 10									
	Condenser Flow Rate	l/s	9.2	28.4	9.2	28.4	9.2	28.4	9.2	28.4	14.2	44.2
	Condenser Pressure Drop	kPa	14.1	98.2	14.1	98.2	14.1	98.2	14.1	98.2	13.9	97.0
	Maximum Water Side Pressure	bar	10									
Maximum Refrigerant Side Pressure	bar	38.6										
Power Supply Voltage 400V, 3 ~, 50 Hz (nominal)	V	360 to 440										
Recommended Minimum System Water Volume	litres	620		726		818		944		1129		
Minimum Ambient Air Temperature	°C	4.5										
Maximum Ambient Air Temperature	°C	46										

High Efficiency (HE) Models			YCWL0385		YCWL0425		YCWL0446		YCWL0531		YCWL0610	
			Min.	Max.	Min.	Max.	Min.	Max.	Min.	Max.	Min.	Max.
Chilled Liquid	Liquid Outlet Temperature (Water)	°C	4.5 to 15									
	Liquid Outlet Temperature (Glycol)	°C	-7 to 15									
	Liquid Outlet Temperature Range	°C	3 to 8									
	Evaporator Flow Rate	l/s	9.5	39.4	8.8	39.4	12.6	41.0	12.6	41.0	12.6	41.0
	Evaporator Pressure Drop	kPa	11.3	154.6	11.8	180.0	14.7	123.9	14.7	123.9	14.7	123.9
Maximum Water Side Pressure	bar	10										
Cooling Liquid	Liquid Outlet Temperature	°C	23 to 50									
	Liquid Outlet Temperature Range	°C	3 to 10									
	Condenser Flow Rate	l/s	14.2	44.2	11.4	44.2	16.4	44.2	16.4	44.2	16.4	44.2
	Condenser Pressure Drop	kPa	16.8	117.6	13.9	142.9	16.8	92.0	16.8	92.0	16.8	92.0
	Maximum Water Side Pressure	bar	10									
Maximum Refrigerant Side Pressure	bar	38.6										
Power Supply Voltage 400V, 3 ~, 50 Hz (nominal)	V	360 to 440										
Recommended Minimum System Water Volume	litres	1244		1353		1432		1670		1914		
Minimum Ambient Air Temperature	°C	4.5										
Maximum Ambient Air Temperature	°C	46										

OPERATING LIMITATIONS - YCRL

YCRL Condenserless Models			YCRL0200		YCRL0230		YCRL0260		YCRL0300		YCRL0345	
			Min.	Max.	Min.	Max.	Min.	Max.	Min.	Max.	Min.	Max.
Chilled Liquid	Liquid Outlet Temperature (Water)	°C	4.5 to 15									
	Liquid Outlet Temperature Range	°C	3 to 8									
	Evaporator Flow Rate	l/s	6.3	22.4	8.8	39.4	6.3	24.3	6.3	24.3	8.8	39.4
	Evaporator Pressure Drop	kPa	10.4	104.8	11.8	180.0	7.6	90.7	7.6	90.7	11.8	180.0
	Maximum Water Side Pressure	bar	10									
Saturated Discharge Temperature		°C	26 to 55									
Maximum Refrigerant Side Pressure		bar	38.6									
Power Supply Voltage 400V, 3 ~, 50 Hz (nominal)		V	360 to 440									
Recommended Minimum System Water Volume		litres	620		726		818		944		1129	
Minimum Ambient Air Temperature		°C	4.5									
Maximum Ambient Air Temperature		°C	46									

YCRL Condenserless Models			YCRL0385		YCRL0445		YCRL0530		YCRL0610	
			Min.	Max.	Min.	Max.	Min.	Max.	Min.	Max.
Chilled Liquid	Liquid Outlet Temperature (Water)	°C	4.5 to 15							
	Liquid Outlet Temperature Range	°C	3 to 8							
	Evaporator Flow Rate	l/s	9.5	39.4	12.6	41.0	12.6	41.0	12.6	41.0
	Evaporator Pressure Drop	kPa	11.3	154.6	14.7	123.9	14.7	123.9	14.7	123.9
	Maximum Water Side Pressure	bar	10							
Saturated Discharge Temperature		°C	26 to 55							
Maximum Refrigerant Side Pressure		bar	38.6							
Power Supply Voltage 400V, 3 ~, 50 Hz (nominal)		V	360 to 440							
Recommended Minimum System Water Volume		litres	1244		1432		1670		1914	
Minimum Ambient Air Temperature		°C	4.5							
Maximum Ambient Air Temperature		°C	46							

PHYSICAL DATA - YCWL

Standard Efficiency (SE) YCWL Models			0240	0291	0346	0395
Number of refrigerant circuits			2			
Refrigerant Charge	Circuit 1 / Circuit 2	kg	27/27	29.5/29.5	36.5/36.5	60/60
Oil Charge	Circuit 1 / Circuit 2	kg	9.3/9.3	11.8/11.8	12.6/11.8	12.6/12.6
Compressor	Number of Compressors		4			
	Type		Scroll			
	Capacity Control	%	100/76/ 51/25	100 /76/ 50/24	100/72/ 50/21	100/75/ 51/25
Evaporator	Number of Evaporator		1			
	Type		Shell and Tubes			
	Water Volume	litre	153	185	194	194
	Water Connections	Inch	6	6	6	6
Condenser	Number of Condenser		1			
	Type		Shell and Tubes			
	Water Volume	litre	74	102	102	133
	Water Connections	Inch	4	4	4	5
Dimensions	Length	mm	3199	3199	3153	3153
	Width	mm	859	859	859	859
	Height	mm	1751	1834	1825	1819
Weight	Shipping Weight	kg	1759	2101	2098	2130
	Operating Weight	kg	1895	2297	2303	2366

High Efficiency (HE) YCWL Models			0200	0230	0260	0301	0346
Number of refrigerant circuits			2				
Refrigerant Charge	Circuit 1 / Circuit 2	kg	29.5/29.5	41/41	36.5/36.5	36.5/36.5	70.5/70.5
Oil Charge	Circuit 1 / Circuit 2	kg	8.3/8.3	12.4/12.4	9.3/8.3	14/12.4	9.3/9.3
Compressor	Number of Compressors		4				
	Type		Scroll				
	Capacity Control	%	100/74/ 48/23	100/71/ 49/22	100/74/ 49/24	100/74/ 49/24	100/71/ 49/20
Evaporator	Number of Evaporator		1				
	Type		Shell and Tubes				
	Water Volume	litre	185	220	194	194	220
	Water Connections	Inch	6	8	6	6	8
Condenser	Number of Condenser		1				
	Type		Shell and Tubes				
	Water Volume	litre	102	102	102	102	167
	Water Connections	Inch	4	4	4	4	5
Dimensions	Length	mm	3159	3132	3153	3153	3132
	Width	mm	859	859	859	859	859
	Height	mm	1717	1895	1825	1825	1943
Weight	Shipping Weight	kg	1771	1948	1954	2051	2410
	Operating Weight	kg	1967	2179	2159	2256	2708

High Efficiency (HE) YCWL Models			0385	0425	0446	0531	0610
Number of refrigerant circuits			2				
Refrigerant Charge	Circuit 1 / Circuit 2	kg	77/77	59/59	88.5/88.5	88.5/88.5	88.5/88.5
Oil Charge	Circuit 1 / Circuit 2	kg	14/14	12.6/12.6	17.7/17.7	18.9/17.7	18.9/18.9
Compressor	Number of Compressors		6	4	6		
	Type		Scroll				
	Capacity Control	%	100/83/66 /49/33/17	100/74/ 49/24	100/83/65 /48/32/17	100/82/66 /46/32/13	100/84/67 /49/32/16
Evaporator	Number of Evaporator		1				
	Type		Shell and Tubes				
	Water Volume	litre	251	220	292	292	292
	Water Connections	Inch	8	8	8	8	8
Condenser	Number of Condenser		1				
	Type		Shell and Tubes				
	Water Volume	litre	198	133	224	224	224
	Water Connections	Inch	5	5	5	5	5
Dimensions	Length	mm	3689	3132	3643	3643	3643
	Width	mm	885	859	885	885	885
	Height	mm	1977	1893	1969	1969	1969
Weight	Shipping Weight	kg	2707	2204	3066	3030	2993
	Operating Weight	kg	3065	2467	3492	3455	3417

PHYSICAL DATA - YCRL

Condenserless YCRL Models			0200	0230	0260	0300	0345
Number of refrigerant circuits			2				
Oil Charge	Circuit 1 / Circuit 2	kg	8.3/8.3	12.4/12.4	9.3/8.3	14/12.4	9.3/9.3
Compressor	Number of Compressors		4				
	Type		Scroll				
	Capacity Control	%	100/74/ 48/23	100/71/ 49/22	100/74/ 49/24	100/74/ 49/24	100/71/ 49/20
Evaporator	Number of Evaporator		1				
	Type		Shell and Tubes				
	Water Volume	litre	185	220	194	194	220
	Water Connections	Inch	6	8	8	8	8
Connection Sizes	Discharge Line (circuit 1 - circuit 2)	Inch	2 1/8-2 1/8	2 1/8-2 1/8	2 1/8-2 1/8	2 5/8-2 5/8	2 5/8-2 5/8
	Liquid Line (circuit 1 - circuit 2)	Inch	7/8-7/8	1 1/8-7/8	1 1/8-1 1/8	1 1/8-1 1/8	1 1/8-1 1/8
Dimensions	Length	mm	3086	3061	3076	3076	3061
	Width	mm	826	856	843	843	856
	Height	mm	1438	1615	1547	1544	1608
Weight	Shipping Weight	kg	1244	1421	1427	1608	1658
	Operating Weight	kg	1338	1551	1531	1711	1788

Condenserless YCRL Models			0385	0445	0530	0610
Number of refrigerant circuits			2			
Oil Charge	Circuit 1 / Circuit 2	kg	14/14	17.7/17.7	18.9/17.7	18.9/18.9
Compressor	Number of Compressors		6			
	Type		Scroll			
	Capacity Control	%	100/83/66 /49/33/17	100/83/65 /48/32/17	100/82/66 /46/32/13	100/84/67 /49/32/16
Evaporator	Number of Evaporator		1			
	Type		Shell and Tubes			
	Water Volume	litre	251	292	292	292
	Water Connections	Inch	8	8	8	8
Connection Sizes	Discharge Line (circuit 1 - circuit 2)	Inch	2 5/8-2 5/8	2 5/8-2 5/8	2 5/8-2 5/8	2 5/8-2 5/8
	Liquid Line (circuit 1 - circuit 2)	Inch	1 1/8-1 1/8	1 1/8-1 1/8	1 3/8-1 1/8	1 3/8-1 3/8
Dimensions	Length	mm	3617	3576	3576	3576
	Width	mm	965	965	965	902
	Height	mm	1641	1638	1641	1641
Weight	Shipping Weight	kg	1904	2224	2187	2150
	Operating Weight	kg	2064	2425	2388	2351

6

ELECTRICAL DATA - YCWL/SE MODELS

Standard Efficiency Units						
YCWL	Nominal Running Conditions		Maximum Running Conditions		Start up Amps Direct on Line	Start up Amps Optional Soft Start
	kW	Amps⁽¹⁾ at 400 V	Amps⁽²⁾ at 360V	Amps⁽²⁾ at 400V		
	without Power Factor Correction					
	with Optional Power Factor Correction Fitted					
0240	48	90	116	114	293	226
	48	80	110	105	288	221
0291	61	117	147	144	360	278
	61	100	138	131	352	270
0346	69	127	166	160	403	288
	69	114	159	149	392	281
0395	77	136	185	176	412	294
	77	127	179	168	408	290

Compressor Data

Standard Efficiency (SE) Models	System	Compressor	Locked Rotor Conditions - Amps at 400V	
			Direct on Line	Optional Soft Start
YCWL0240SE	1 & 2	ZP 235	225	158
YCWL0291SE	1 & 2	ZP 295	272	190
YCWL0346SE	1	ZP 385	310	192
	2	ZP 295	272	190
YCWL0395SE	1 & 2	ZP 385	310	192

ELECTRICAL DATA - YCWL/YCRL HE MODELS

High Efficiency Units						
YCWL/ YCRL	Nominal Running Conditions		Maximum Running Conditions		Start up Amps Direct on Line	Start up Amps Optional Soft Start
	kW	Amps ⁽¹⁾ at 400 V	Amps ⁽²⁾ at 360V	Amps ⁽²⁾ at 400V		
					without Power Factor Correction	
	with Optional Power Factor Correction Fitted					
0200	37	72	90	90	241	187
	37	63	86	82	237	183
0230	44	81	102	101	284	217
	44	72	97	93	277	212
0260	48	90	114	113	293	226
	48	80	109	104	288	221
0301/0300	61	117	147	144	360	278
	61	100	138	130	352	270
0346/0345	69	128	168	162	403	289
	69	115	161	151	393	282
0385	73	137	174	171	339	272
	73	121	166	158	329	262
0425	79	138	190	180	414	296
	79	129	184	172	409	291
0446/0445	92	176	221	217	419	337
	92	151	208	197	402	320
0531/0530	105	192	251	242	467	352
	105	172	240	225	450	339
0610	118	207	280	266	483	365
	118	193	272	254	473	355

(1) For YCWL units, nominal running amps at 35°C leaving condenser liquid temperature and 7°C leaving chilled liquid temperature

For YCRL units, nominal running amps at 45°C saturated discharge temperature and 7°C leaving chilled liquid temperature

(2) Maximum running amps at maximum operating conditions

(3) Start-up amps is the largest compressor starting with all other compressors operating at nominal conditions at 400V

(4) Soft Start is only fitted on the largest compressor in each system

Compressor Data

High Efficiency (HE) Models	System	Compressor	Locked Rotor Conditions - Amps at 400V	
			Direct on Line	Optional Soft Start
YCWL/YCRL0200HE	1 & 2	ZP 180	187	133
YCWL/YCRL0230HE	1	ZP 235	225	158
	2	ZP 180	187	133
YCWL/YCRL0260HE	1 & 2	ZP 235	225	158
YCWL/YCRL0301HE	1 & 2	ZP 295	272	190
YCWL/YCRL0346HE	1	ZP 385	310	192
	2	ZP 295	272	190
YCWL/YCRL0385HE	1 & 2	ZP 235	225	158
YCWL0425HE	1 & 2	ZP 385	310	192
YCWL/YCRL0446HE	1 & 2	ZP 295	272	190
YCWL/YCRL0531HE	1	ZP 385	310	192
	2	ZP 295	272	190
YCWL/YCRL0610HE	1 & 2	ZP 385	310	192

**DIMENSIONS - YCWL0240SE, YCWL0291SE, YCWL0346SE, YCWL0395SE,
YCWL0200HE, YCWL0230HE, YCWL0260HE, YCWL0301HE, YCWL0346HE YCWL0425HE**

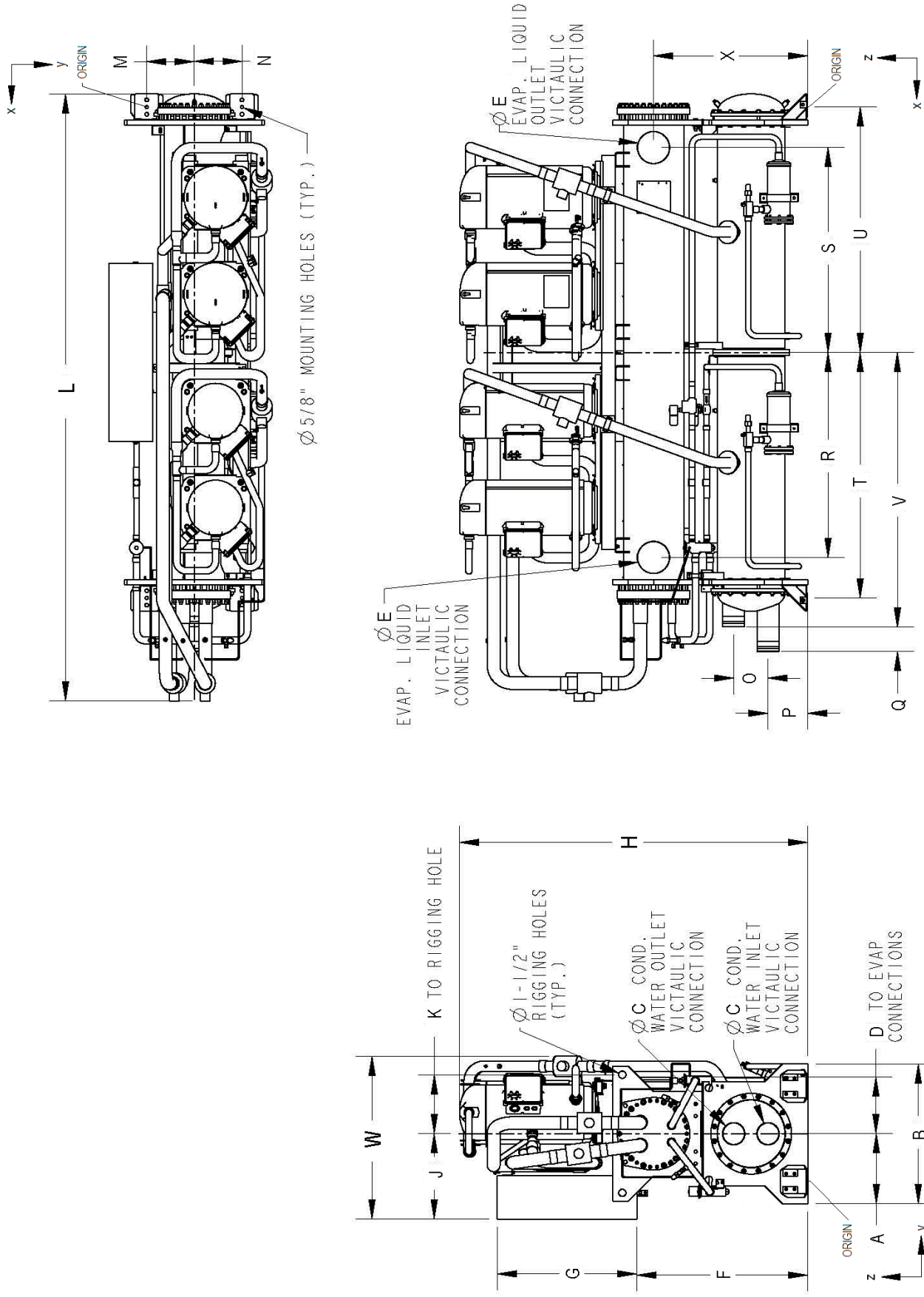

YCWL	0240SE	0291SE	0346SE	0395SE	0200HE	0230HE	0260HE	0301HE	0346HE	0425HE
Dim.	mm	mm	mm	mm	mm	mm	mm	mm	mm	mm
W	859	859	859	859	859	859	859	859	860	859
H	1751	1834	1825	1819	1717	1895	1825	1825	1943	1893
L	3199	3199	3153	3153	3159	3132	3153	3153	3132	3132
A	368	368	368	368	368	368	368	368	381	368
B	737	737	737	737	737	737	737	737	762	737
C	102	102	102	127	102	102	102	102	127	127
D	394	299	394	394	299	407	394	394	407	407
E	152	152	152	152	152	203	152	152	203	203
F	901	901	978	978	901	1016	978	978	1067	1016
G	737	737	737	737	737	737	737	737	737	737
J	450	450	450	450	450	450	450	450	450	450
K	227	311	311	311	311	324	311	311	324	324
M	251	251	251	251	251	251	251	251	251	251
N	251	251	251	251	251	251	251	251	251	251
O	140	181	181	181	181	181	181	181	181	181
P	230	210	210	210	210	210	210	210	235	210
Q	130	130	130	133	130	130	130	130	132	133
R	1073	1080	1080	1080	1080	1054	1080	1080	1054	1054
S	1073	1080	1080	1080	1080	1054	1080	1080	1054	1054
T	1293	1293	1293	1293	1293	1293	1293	1293	1293	1293
U	1293	1293	1293	1293	1293	1293	1293	1293	1293	1293
V	1445	1445	1445	1445	1445	1445	1445	1445	1470	1455
X	772	813	813	813	813	845	813	813	895	845
CG-X	1293	1294	1294	1293	1294	1294	1294	1294	1294	1293
CG-Y	232	229	229	232	241	238	235	229	251	232
CG-Z										
Shipping Weight (kg)	1759	2101	2098	2130	1771	1948	1954	2051	2410	2204
Operating Weight (kg)	1895	2297	2303	2366	1967	2180	2159	2256	2707	2468

6

DIMENSIONS - YCWL0385HE, YCWL0446HE, YCWL0531HE AND YCWL0610HE

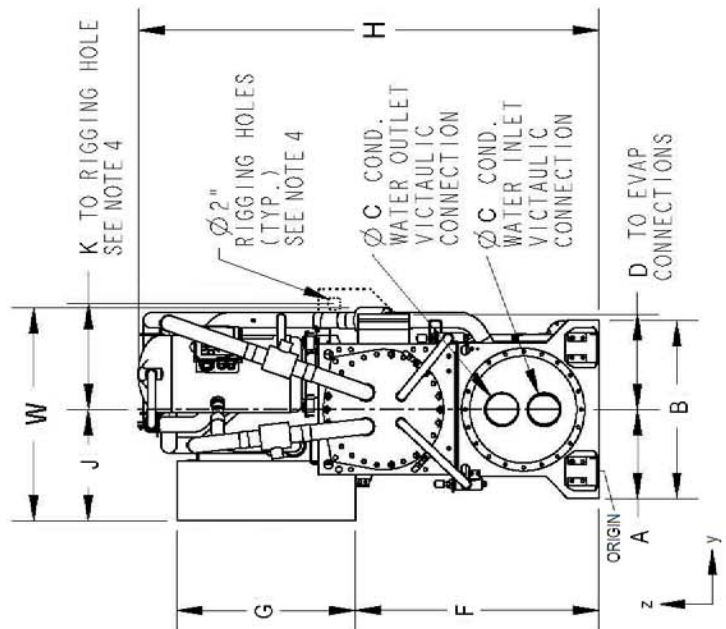
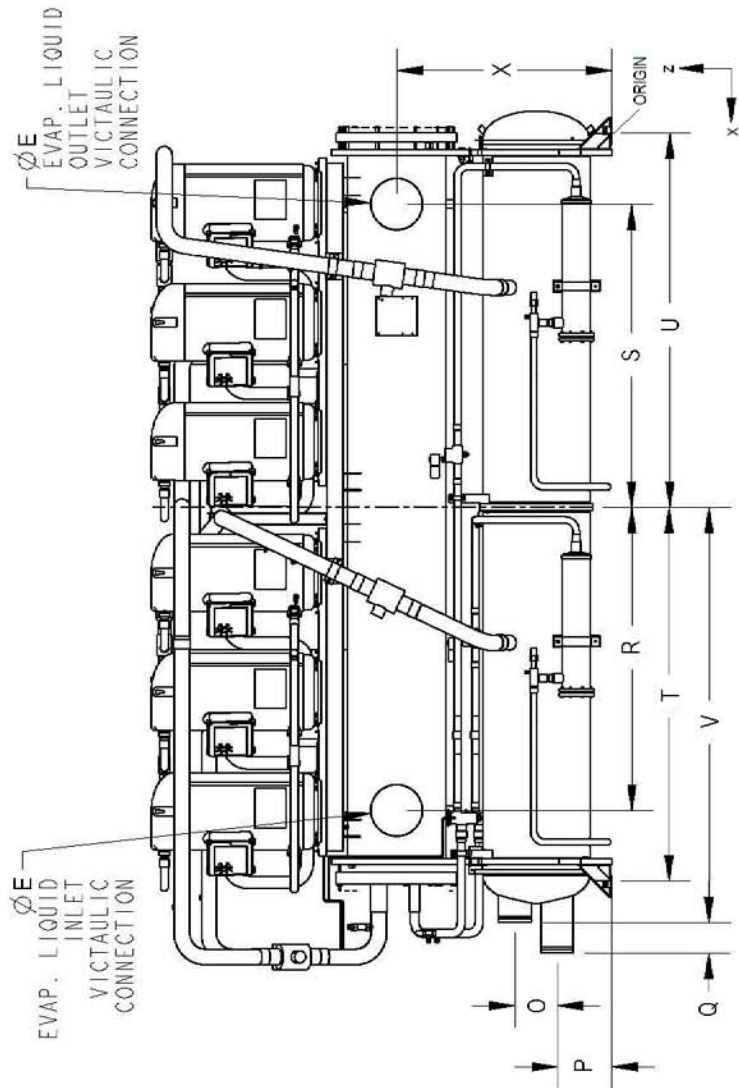
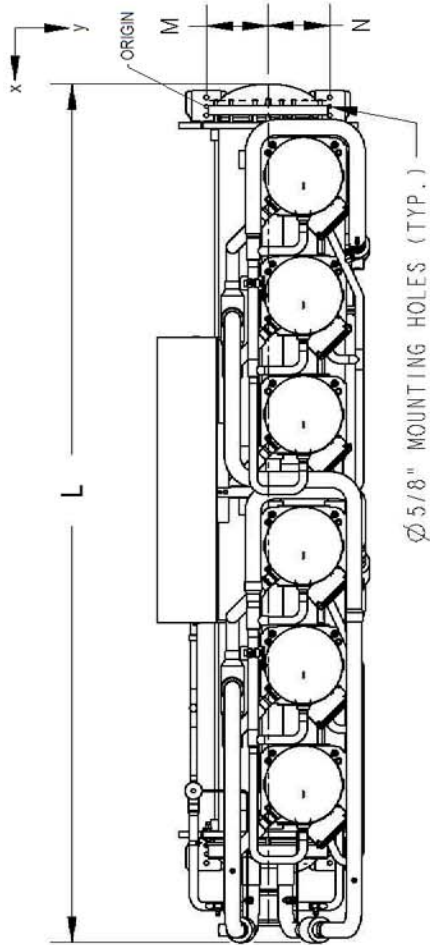

YCWL	0385HE	0446HE	0531HE	0610HE
Dim.	mm	mm	mm	mm
W	885	885	885	885
H	1977	1969	1969	1969
L	3689	3643	3643	3643
A	381	381	381	381
B	762	762	762	762
C	127	127	127	127
D	407	406	406	406
E	203	203	203	203
F	1041	1041	1041	1041
G	737	737	737	737
J	450	450	450	450
K	452	452	452	452
M	264	264	264	264
N	264	264	264	264
O	181	181	181	181
P	235	235	235	235
Q	132	132	132	132
R	1295	1295	1295	1295
S	1295	1295	1295	1295
T	1598	1598	1598	1598
U	1598	1598	1598	1598
V	1774	1774	1774	1774
X	921	921	921	921
CG-X	1597	1597	1597	1597
CG-Y	235	229	229	232
CG-Z				
Shipping Weight (kg)	2707	3066	3030	2993
Operating Weight (kg)	3065	3491	3454	3418

DIMENSIONS - YCRL0200HE, YCRL0230HE, YCRL0260HE, YCRL0300HE, YCRL0345HE

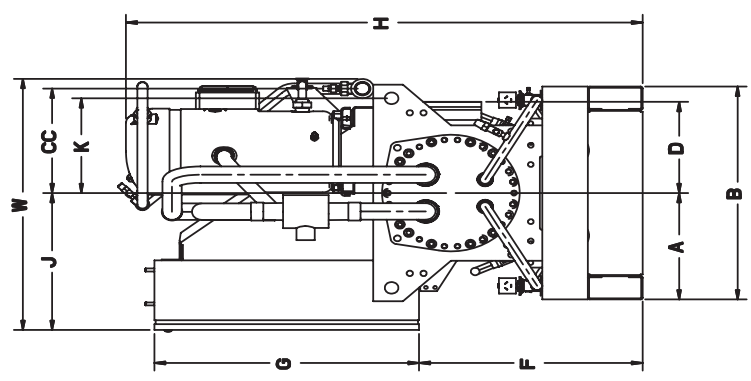
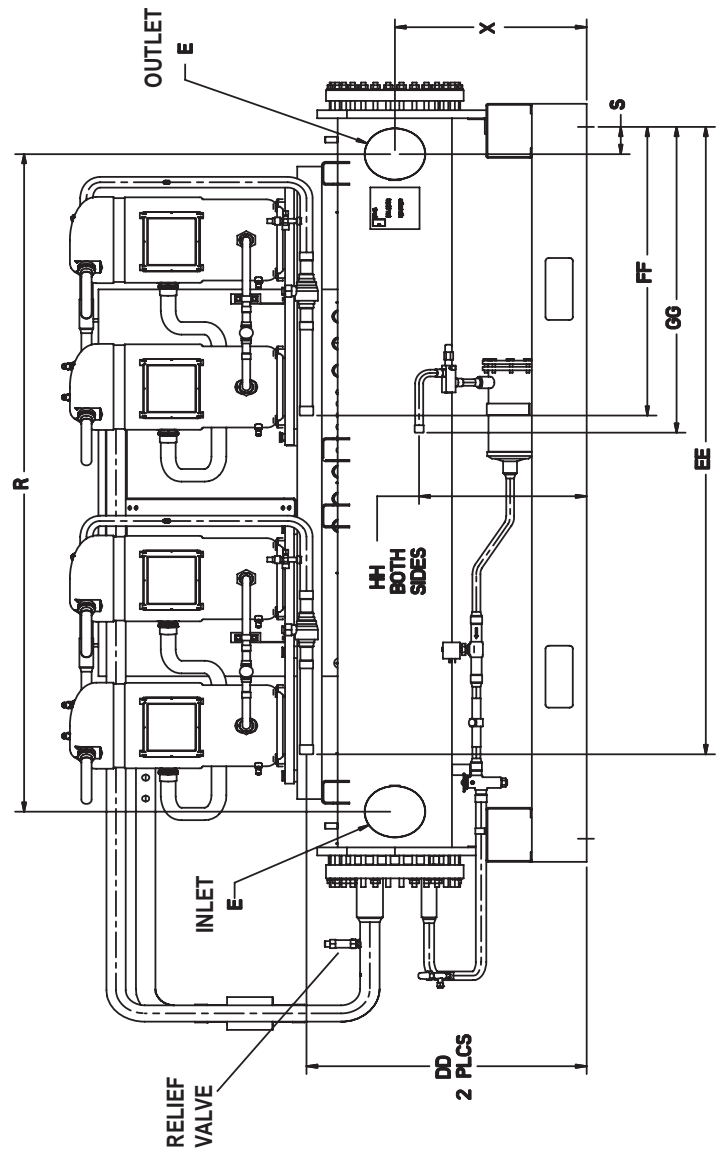
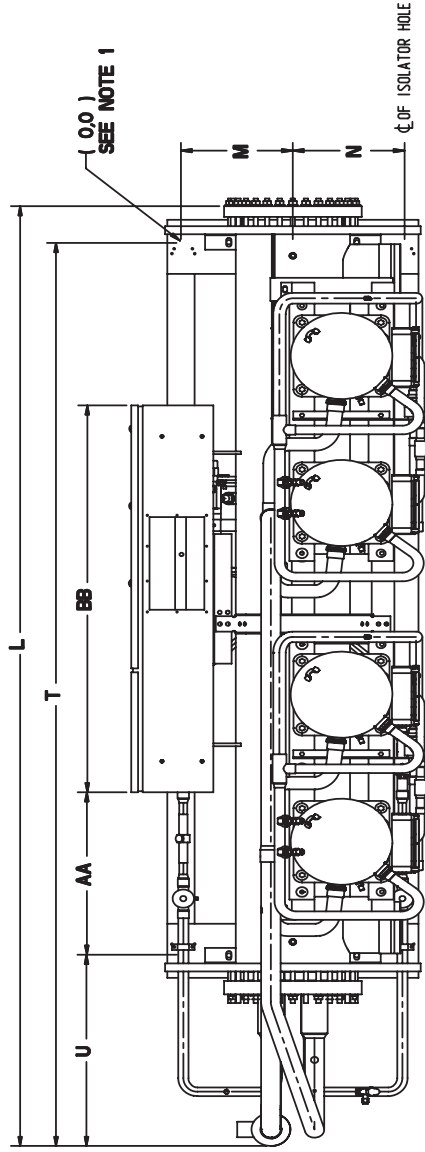

- NOTES:**
1. Recommended service clearances.
 Rear to wall: 20" (508mm)
 Front to wall: 36" (915mm)
 Top: 43" (1092mm)
 Tube cleaning and removal: 132" (3353 mm) either end
 2. Relief valve connection sizes.
 Low side (suction line): 1/2" flare

YCRL	0200HE	0230HE	0260HE	0300HE	0345HE
Dim.	mm	mm	mm	mm	mm
W	826	856	843	843	856
H	1,438	1,615	1,547	1,544	1,608
L	3,086	3,061	3,076	3,076	3,061
A	351	351	351	351	351
B	699	699	699	699	699
D	300	406	396	396	406
E	219	219	168	168	219
F	622	737	699	699	737
G	737	737	737	737	737
J	450	450	450	450	450
K	312	325	343	343	325
M	312	312	312	312	312
N	312	312	312	312	312
R	2,159	2,108	2,159	2,159	2,108
S	89	114	165	89	114
T	2,964	2,939	2,959	2,959	2,939
U	627	602	622	622	561
X	533	564	533	533	564
AA	533	533	533	533	533
BB	1,270	1,270	1,270	1,270	1,270
CC	343	343	312	312	356
DD	780	838	769	770	838
EE	2,060	2,085	1,910	1,999	2,009
FF	947	886	785	874	884
GG-1	1,003	1,003	914	965	1,041
GG-2	1,003	1,003	914	965	1,041
HH	465	373	373	373	378

6

DIMENSIONS - YCRL0385HE, YCRL0445HE, YCRL0530HE AND YCRL0610HE

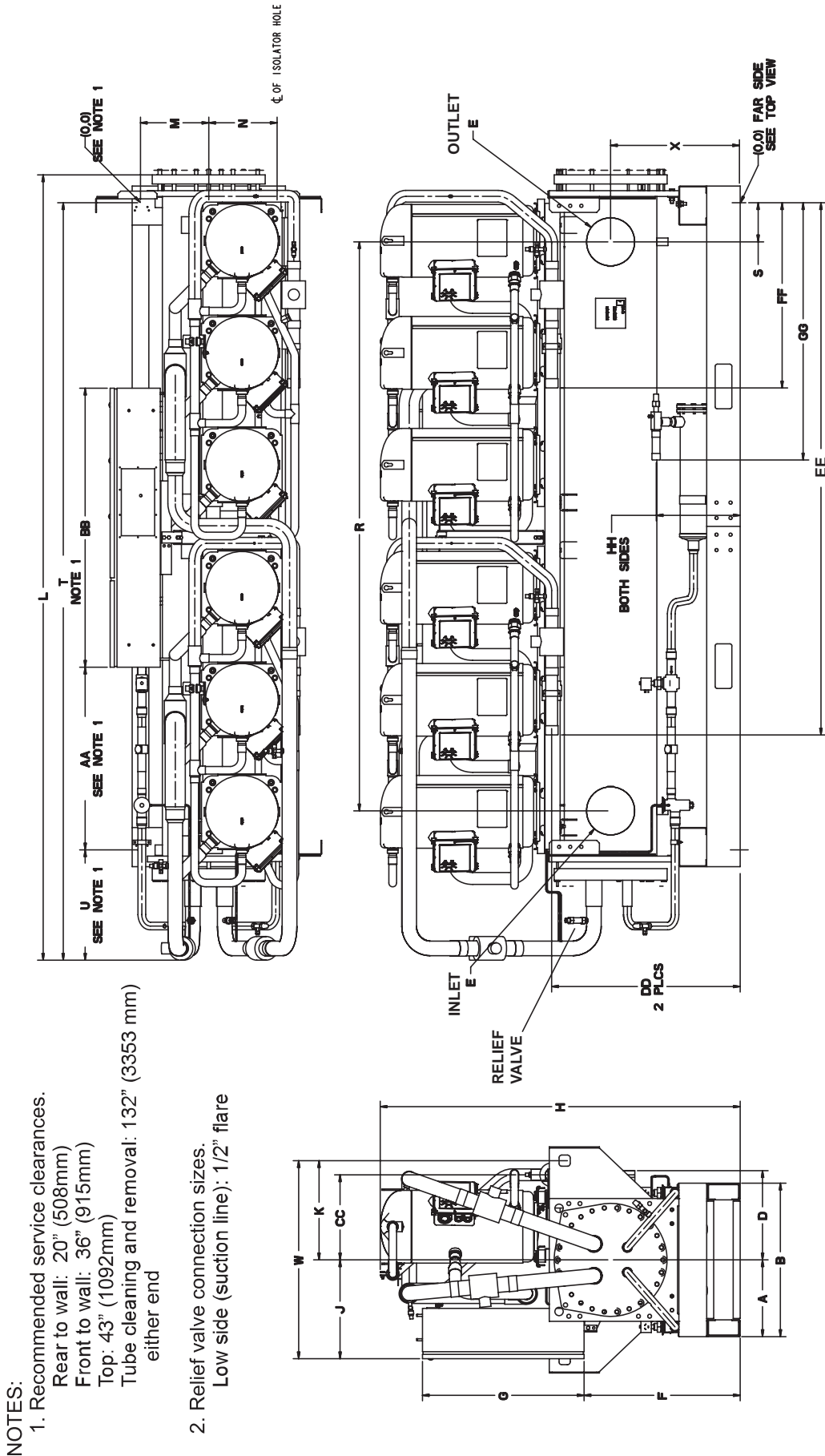

- NOTES:**
1. Recommended service clearances.
 Rear to wall: 20" (508mm)
 Front to wall: 36" (915mm)
 Top: 43" (1092mm)
 Tube cleaning and removal: 132" (3353 mm) either end
 2. Relief valve connection sizes.
 Low side (suction line): 1/2" flare

YCRL	0385HE	0445HE	0530HE	0610HE
Dim.	mm	mm	mm	mm
W	965	965	965	902
H	1641	1638	1641	1641
L	3617	3576	3576	3576
A	351	351	351	351
B	699	699	699	699
D	406	406	406	406
E	219	219	219	219
F	711	711	711	711
G	737	737	737	737
J	450	450	450	450
K	452	389	452	452
M	312	312	312	312
N	312	312	312	312
R	2591	2591	2591	2591
S	178	178	178	178
T	3495	3449	3449	3449
U	549	503	503	503
X	592	589	592	587
AA	833	833	833	833
BB	1270	1270	1270	1270
CC	381	452	389	389
DD	859	859	859	859
EE	2423	2423	2423	2423
FF	843	843	843	843
GG-1	1466	1364	1171	1171
GG-2	1466	1364	1364	1171
HH	378	378	384	384

YCWL WEIGHT DISTRIBUTION & VIBRATION ISOLATOR DATA

Units shipped before 15 June 2008

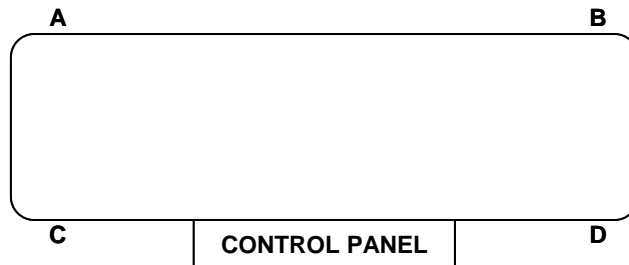

Standard Efficiency Units					
Weight Distribution (kg)					
Model YCWL	A	B	C	D	Total
0240SE	509	509	439	439	1895
0291SE	628	628	520	520	2297
0346SE	627	627	524	524	2303
0395SE	640	640	543	543	2366

High Efficiency Units					
Weight Distribution (kg)					
Model YCWL	A	B	C	D	Total
0200HE	509	509	474	474	1967
0230HE	571	571	518	518	2179
0260HE	575	575	504	504	2159
0301HE	613	613	515	515	2256
0346HE	744	744	610	610	2708
0385HE	852	852	681	681	3065
0425HE	665	665	568	568	2467
0446HE	997	997	749	749	3492
0531HE	982	982	746	746	3455
0610HE	967	967	742	742	3417

Part Number	Colour (Type)	Standard Efficiency Units				High Efficiency Units											
		YCWL0240SE	YCWL0291SE	YCWL0346SE	YCWL0395SE	YCWL0200HE	YCWL0230HE	YCWL0260HE	YCWL0301HE	YCWL0346HE	YCWL0385HE	YCWL0425HE	YCWL0446HE	YCWL0531HE	YCWL0610HE		
Neoprene Pad Isolators																	
029-24584-002	Yellow (ND-D)	4	4	4	4	4	4	4	4	4	4	4	4	4	4		
029-24584-004	Yellow (ND-DS)												4		4	4	4
25 mm Spring Isolators																	
029-24583-006	Black (CIP-B)	4				4											
029-24583-009	Black Stripe (CIP-C)		4	4	4		4	4	4				4				
029-24583-010	Yellow/Red Stripe (25 mm CIP-C)									4							
029-24583-011	Yellow/Green Stripe (25 mm CIP-C)										4						
029-24583-012	Red/Red Stripe (25 mm CIP-C)												4	4	4	4	
Seismic Isolators																	
029-24585-011	Grey	4	4	4	4	4	4	4	4			4					
029-24585-012	Silver										4	4					
029-24585-013	Grey/Red													4	4	4	

Note: Isolators are identical at all positions.

YCWL WEIGHT DISTRIBUTION & VIBRATION ISOLATOR DATA

Units shipped on or after 15 June 2008

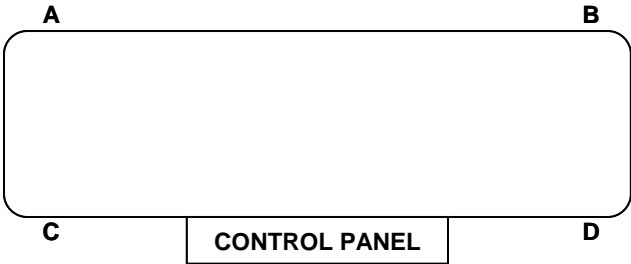

Standard Efficiency Units					
Weight Distribution (kg)					
Model YCWL	A	B	C	D	Total
0240SE	509	509	439	439	1895
0291SE	628	628	520	520	2297
0346SE	627	627	524	524	2303
0395SE	640	640	543	543	2366

High Efficiency Units					
Weight Distribution (kg)					
Model YCWL	A	B	C	D	Total
0200HE	509	509	474	474	1967
0230HE	571	571	518	518	2179
0260HE	575	575	504	504	2159
0301HE	613	613	515	515	2256
0346HE	744	744	610	610	2708
0385HE	852	852	681	681	3065
0425HE	665	665	568	568	2467
0446HE	997	997	749	749	3492
0531HE	982	982	746	746	3455
0610HE	967	967	742	742	3417

Part Number	Colour (Type)	Standard Efficiency Units				High Efficiency Units									
		YCWL0240SE	YCWL0291SE	YCWL0346SE	YCWL0395SE	YCWL0200HE	YCWL0230HE	YCWL0260HE	YCWL0301HE	YCWL0346HE	YCWL0385HE	YCWL0425HE	YCWL0446HE	YCWL0531HE	YCWL0610HE
Durulene Pad Isolators															
029-25335-002	Brick Red	4	4	4	4	4	4	4	4	4					
029-25335-004	Charcoal										4	4	4	4	4
25 mm Spring Isolators															
029-25334-005	White (CP)	4				4									
029-25334-006	Grey/Red (CP)		4	4	4		4	4	4						
029-25334-010	Grey (CP2)									4	4				
029-25334-012	White (CP2)											4	4	4	4
Seismic Isolators															
029-25336-011	Pink	4	4	4	4	4	4	4	4						
029-25336-012	Pink/Grey									4	4	4	4	4	4

Note: Isolators are Identical at all positions.

YCRL WEIGHT DISTRIBUTION & VIBRATION ISOLATOR DATA

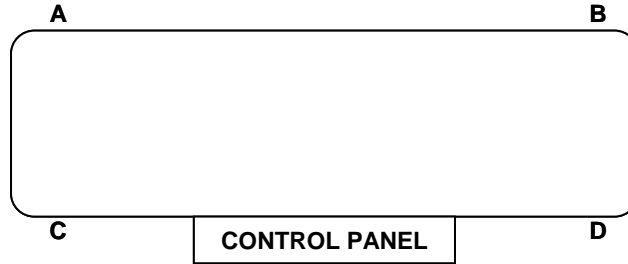

Weight Distribution (kg)					
Model YCRL	A	B	C	D	Total
0200HE	352	352	317	317	1338
0230HE	352	352	317	317	1338
0260HE	352	352	317	317	1338
0300HE	504	504	406	406	1822
0345HE	504	504	406	406	1822
0385HE	629	629	457	457	2172
0445HE	730	730	483	483	2425
0530HE	730	730	483	483	2425
0610HE	730	730	483	483	2425

Part Number	Colour (Type)	High Efficiency Units								
		YCRL0200HE	YCRL0230HE	YCRL0260HE	YCRL0300HE	YCRL0345HE	YCRL0385HE	YCRL0445HE	YCRL0530HE	YCRL0610HE
Durulene Pad Isolators										
029-25335-001	Charcoal	4	4	4						
029-25335-002	Brick Red				4	4	4	4	4	4
25 mm Spring Isolators										
029-25334-004	Grey (CP)	4	4	4						
029-25334-005	White (CP)				4	4				
029-25334-006	Grey/Red (CP)						4			
029-25334-010	Grey (CP2)							4	4	4
Seismic Isolators										
029-25336-010	Red/Black	4	4	4						
029-25336-011	Pink				4	4	4			
029-25336-012	Pink/Grey							4	4	4

Note: Isolators are Identical at all positions.

NEOPRENE ISOLATOR INSTALLATION AND ADJUSTMENT

Units shipped before 15 June 2008

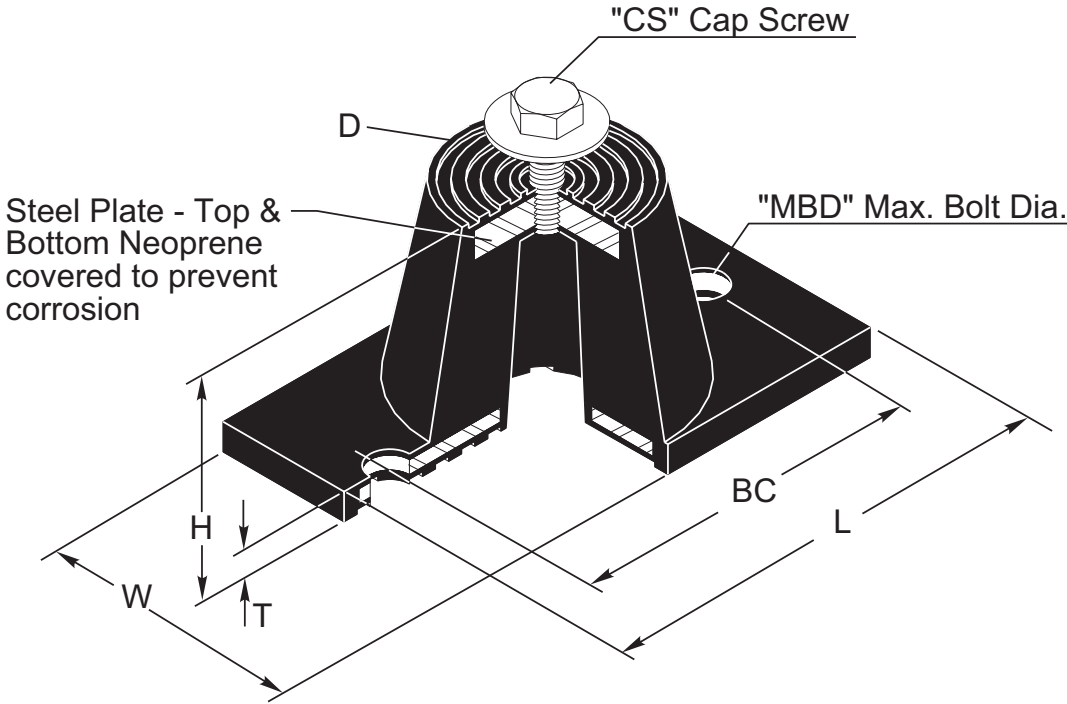

6

Dimension (mm)								
Part No	D	H	L	T	W	BC	CS	MBD
029-24584-002	85.7	69.9	158.8	7.9	101.6	127.0	1/2 - 13 x 1"	13
029-24584-002	86	70	159	8	102	127	1/2 - 13 x 1"	13

INSTALLATION OF NEOPRENE MOUNTS

It is not necessary to bolt the mountings to a concrete pad in most cases. Mountings should always be bolted to the chiller rails. When mountings and the chiller are installed on steel framing above the ground, the mountings should be bolted to the steel framework. Lower the chiller on to the mountings evenly to avoid placing excessive weight on individual isolators.

DURULENE ISOLATOR SPECIFICATIONS

Units shipped on or after 15 June 2008

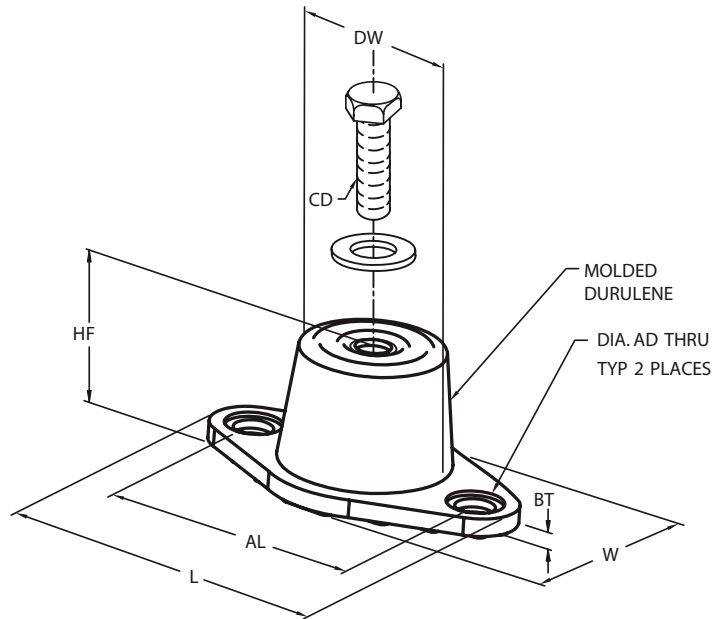

Mount Type	Dimensions (inches)							DW
	L	W	HF	AL	AD	BT	CD	
RD3	5.50	3.38	2.88	4.13	0.56	0.25	1/2-13UNC x 1	2.50
RD4	6.25	4.63	2.75	5.00	0.56	0.38	1/2-13UNC x 1	3.00

Weight Range (kgs)*	Type	Colour	York P/N
255 to 375	RD3	Charcoal	029-25335-001
375 to 766	RD4	Brick Red	029-25335-002
766 to 1361	RD4	Charcoal	029-25335-004

*Values de-rated by 25%

DURULENE ISOLATOR INSTALLATION

Units shipped on or after 15 June 2008

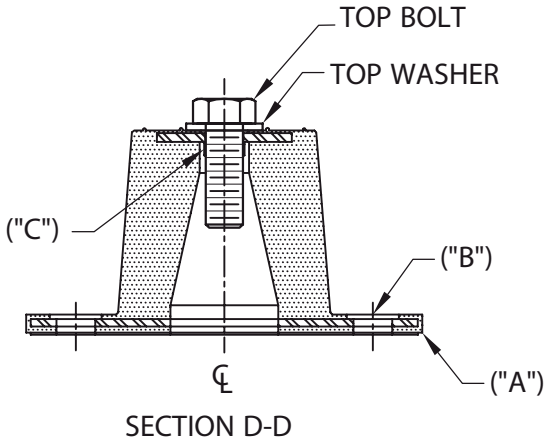
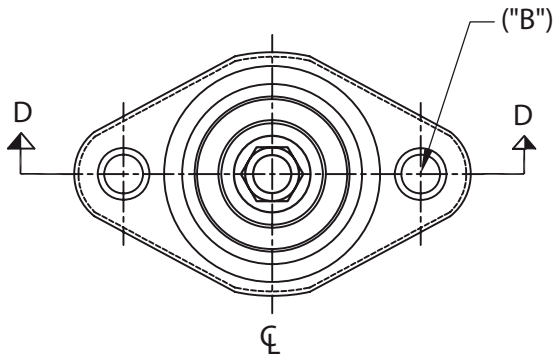

6

1. Read the following instructions before beginning installation.
2. Isolators are shipped fully assembled and are to be positioned in accordance with the submittal drawings or as otherwise recommended.
3. Set isolators on floor, housekeeping pad or subbase, ensuring that all isolator centerlines match the equipment mounting holes. The VMC group recommends that the isolator base ("A") be installed on a level surface. Shim or grout as required, leveling all isolator bases to the same elevation (0.03125-inch maximum difference can be tolerated).
4. Bolt or anchor all isolators to supporting structure utilizing base thru holes ("B").
5. Remove top bolt and top washer. Place equipment on top of isolators so that mounting holes in equipment or base line up with threaded hole ("C").
6. Reinstall top bolt and washer and tighten down.

25 MM ISOLATOR INSTALLATION AND ADJUSTMENT

Units shipped before 15 June 2008

Illustration shows single spring CIP-B or CIP-C mount.

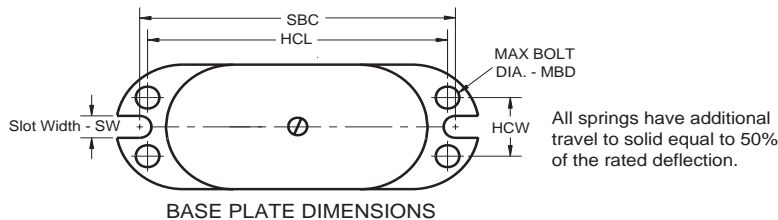
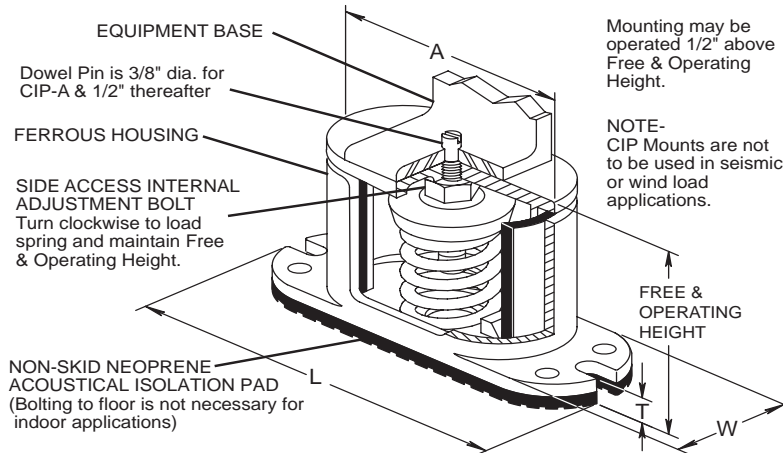

TYPE CIP DIMENSIONS (inches)†

Type	A	L	T	W	SW	HCL	HCW	MBD	SBC	Free Ht.	Min Ht.
CIP-B	5 ³ / ₄	8 ¹ / ₄	1/2	2 ³ / ₄	7/16	6 ¹ / ₂	11/2	3/8	7 ¹ / ₄	6 ¹ / ₈	5 ¹ / ₄
CIP-C	6 ⁵ / ₈	8 ⁷ / ₈	9/16	3 ¹ / ₂	7/16	7 ¹ / ₄	13/4	3/8	7 ⁷ / ₈	6 ³ / ₄	6 ³ / ₄

†Casting dimensions may vary ±1/8"

- Floor or steel frame should be level and smooth.
- For pad installations, isolators do not normally require bolting. If necessary, anchor isolators to floor through bolt holes in the base plate.
- Lubricate the threads of adjusting bolt. Loosen the hold down bolts to allow for isolator adjustment.
- Block the equipment 10mm (1/4") higher than the specified free height of the isolator. To use the isolator as blocking for the equipment, insert a 10mm (1/4") shim between the upper load plate and vertical uprights. Lower the equipment on the blocking or shimmed isolators.
- Complete piping and fill equipment with water, refrigerant, etc.
- Turn leveling bolt of first isolator four full revolutions and proceed to each mount in turn.
- Continue turning leveling bolts until the equipment is fully supported by all mountings and the equipment is raised free of the spacer blocks or shims. Remove the blocks or shims.
- Turn the leveling bolt of all mountings in either direction in order to level the installation.
- Tighten the nuts on the hold down bolts.
- Installation is now complete.



Isolators must be bolted to the substructure and the equipment must be bolted to the isolators when outdoor equipment is exposed to wind forces.

25 MM ISOLATOR SPECIFICATION

Units shipped on or after 15 June 2008

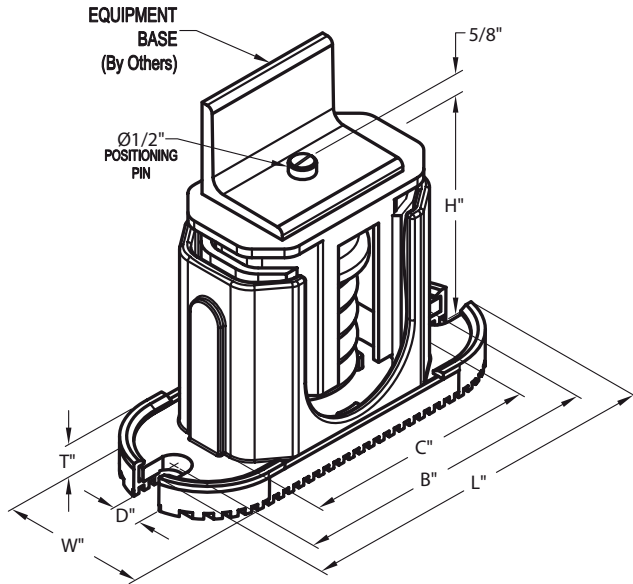

6

Dimensions (inches)							
Mount Type	W	D	L	B	C	T	H
CP	3	0.625	7.75	6.5	4.75	0.5	5.625
C2P	3	0.625	10.5	9.25	7.75	0.5625	6

Weight Range (kgs)*	Type	Colour	York P/N
345 to 463	CP	Grey	029-25334-004
463 to 525	CP	White	029-25334-005
525 to 688	CP	Grey/Red	029-25334-006
694 to 926	C2P	Grey	029-25334-010
926 to 1094	C2P	White	029-25334-012

*Values de-rated by 15%

Notes:

1. Use either all CP's or all CP2's at all locations on a unit.
2. Installation requires bolting or anchoring mount to support structure with a 2 x 0.625" diameter bolts or 2 x 0.5" diameter concrete anchors.
3. All springs are designed for 50% over-travel.

25 MM ISOLATOR INSTALLATION

Units shipped on or after 15 June 2008

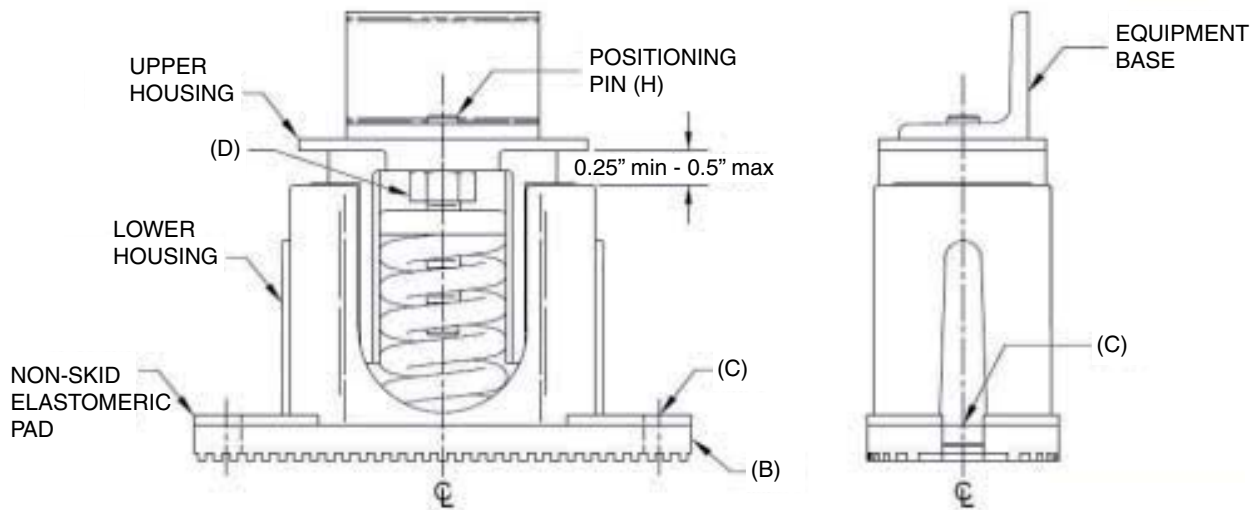

1. Read the following instructions before beginning installation.
2. Isolators are shipped fully assembled and are to be positioned in accordance with the submittal drawings or as otherwise recommended.
3. Set isolators on floor, housekeeping pad or subbase, ensuring that all isolators centrelines match the equipment mounting holes. The VMC group recommends that the isolator base ("B") be installed on a level surface. Shim or grout as required, leveling all isolator bases to the same elevation (0.25-inch maximum difference can be tolerated).
4. Bolt or anchor all isolators to supporting structure utilising base slotted holes ("C").
5. Place equipment on top of isolators making sure that mounting holes of the equipment line up with isolator positioning pin ("H").
6. The adjustment process can only begin after the equipment or machine is at its full operating weight.
7. Adjust each isolator in sequence by turning spring adjusting bolt ("D") one full counterclockwise turn at a time. Repeat this procedure on all isolators, one at a time.
8. Continue adjusting each isolator until a minimum of 0.25" clearance is achieved between the lower housing and upper housing. (See illustration above).
9. Fine adjust isolators to level equipment.

SEISMIC ISOLATOR INSTALLATION AND ADJUSTMENT

Units shipped before 15 June 2008

TO INSTALL AND ADJUST MOUNTS

1. Supports for mountings must be leveled to installation's acceptable tolerances.
2. Mountings not subjected to seismic or wind forces do not require bolting to supports.
3. Mountings subjected to seismic or wind forces must be bolted or welded in position.
4. If mountings are welded in position, remove lower friction pad before welding.
5. Set mountings with top channels held in place by the lower restraining nuts and limit stops.
6. Place equipment on mountings and secure by bolting or welding.
7. Hold lower restraining nut in place and turn vertical limit stop bolt counter-clockwise until there is a 1/8" gap between the bolt head and the steel washer.
8. Turn adjustment bolt 8 turns on each mount.
9. Take one additional complete turn on each adjustment bolt in sequence until the top plate lifts off of the lower restraining nuts. Take no additional turns on that mount. Continue with equal turns on the other mounts until the top plates lift off of the lower restraining nuts of all mounts.
10. Hold the limit stop bolt in place and turn the lower restraining nut clockwise and tighten it against the stanchion. Repeat the same procedure on all mounts.
11. Top plate should remain at a fixed elevation, plus or minus 1/8".

6

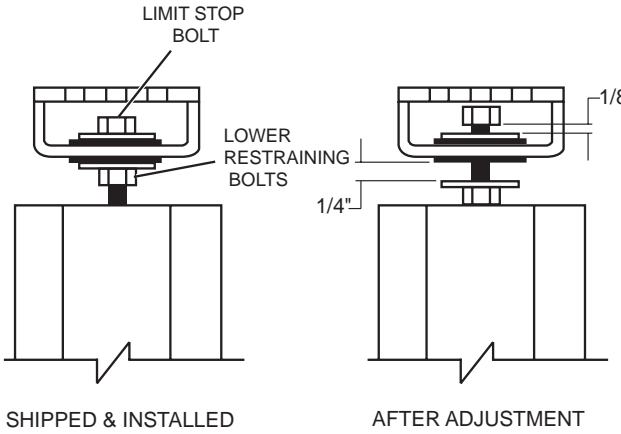
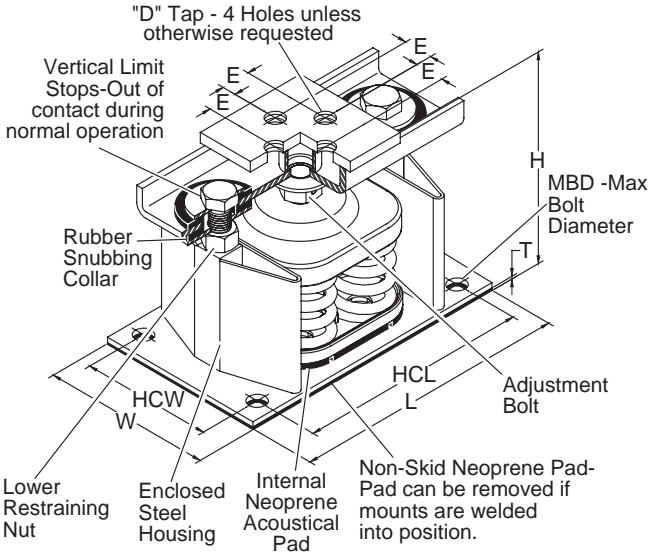

Dimension (mm)									
Part No	H	T	D	E	L	HCL	W	HCW	MBD
029-24585-011									
029-24585-012	215.9	9.5	15.9	34.9	355.6	311.2	133.4	88.9	5/8"
029-24585-013									

50 MM (SEISMIC) ISOLATOR SPECIFICATIONS

Units shipped on or after 15 June 2008

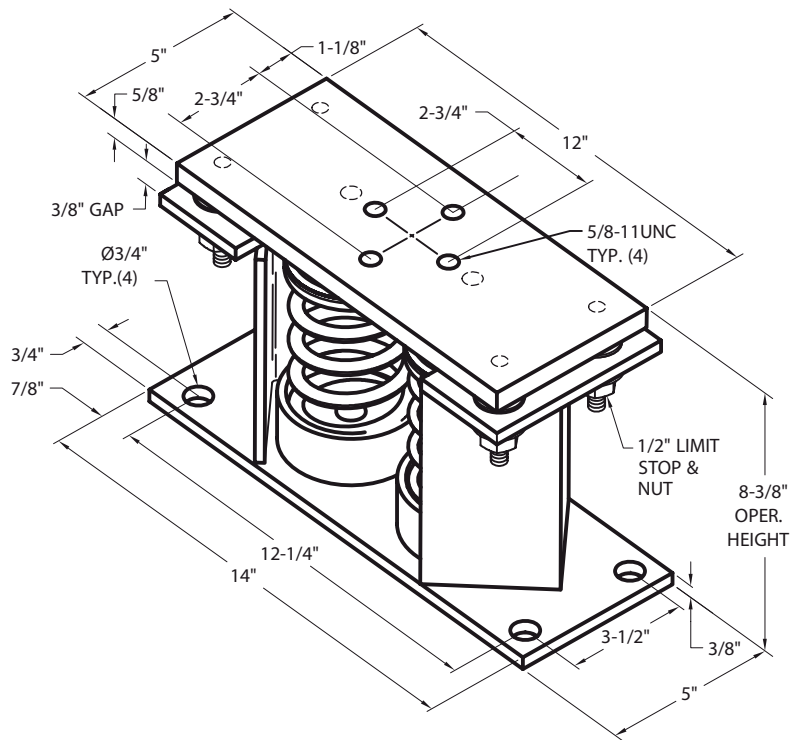

Weight Range (kgs)*	Type	Colour	York P/N
335 to 463	Y2	Red/Black	029-25336-010
463 to 652	Y2	Pink	029-25336-011
652 to 1018	Y2	Pink/Grey	029-25336-012

*Values de-rated by 15%

Notes:

1. All dimensions are in inches, interpret as per ANSI Y14
2. Equipment must be bolted or welded to the top plate to meet allowable seismic ratings.
3. All springs are designed for 50% overload capacity with exception of the 029-25336-013 and 029-25336-014.
4. Consult JCI for concrete installation.

50 MM (SEISMIC) ISOLATOR INSTALLATION AND ADJUSTMENT

Units shipped on or after 15 June 2008

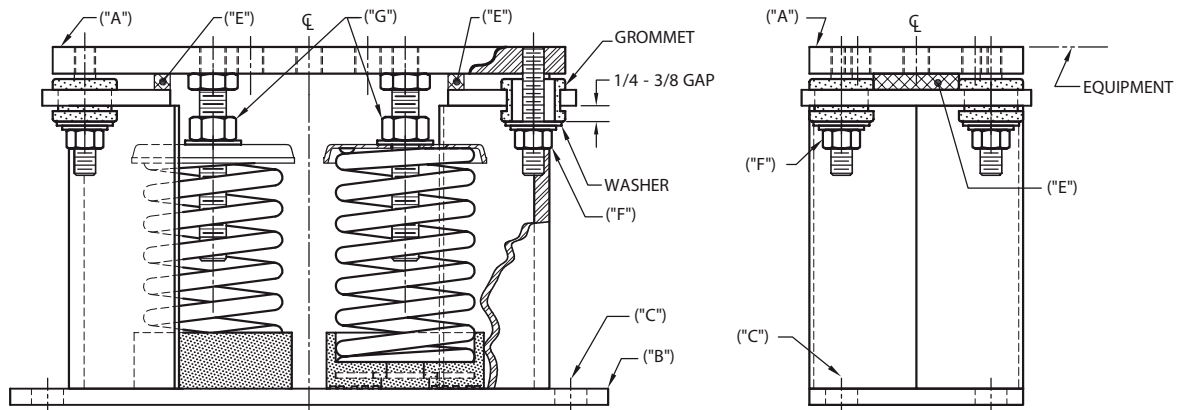

1. Read the following instructions before beginning installation.
2. Isolators are shipped fully assembled and are to be positioned in accordance with the submittal drawings or as otherwise recommended.
3. Set isolators on floor, housekeeping pad, or sub-base, ensuring that all isolator centerlines match the equipment mounting holes. The VMC group recommends that the isolator base plates ("B") be installed on a level surface. Shim or grout as required, leveling all isolator base plates to the same elevation (0.25-inch maximum difference can be tolerated).
4. Bolt or anchor all isolators to supporting structure utilizing base plate thru holes ("C") or weld base plate to supporting structure with 0.375" fillet weld 2" long @ 4" on centre around entire base plate or as engineered for specific load and or field conditions.
5. Isolators are shipped to the job site with (2) removable spacer shims ("E") between the top plate and the housing. These shims must be in place when the equipment is positioned over the isolators.
6. With all shims ("E") in place, position equipment on top of plate ("A") of isolator. Bolt equipment securely to top plate of isolator using a minimum of 2 x 0.625" UNC A325 GRADE 5 SAE bolts or weld equipment or bracket to the top plate ("A") of isolator with a minimum 0.375" fillet welds 2" long @ 3" O.C. for a minimum total weld of 10". (All sides of equipment or bracket resting on top plate ("A") must be welded).
7. The adjustment process can only begin after the equipment or machine is at its full operating weight.
8. Back off each of the 4 limit stop lock nuts ("F") on the isolators 0.5".
9. Adjust each isolator in sequence by turning spring adjusting nuts ("G") one full clockwise turn at a time. Repeat this procedure on all isolators, one at a time. Check the limit stop lock nuts ("F") periodically to ensure that clearance between the washer and rubber grommet is maintained. Stop adjustment of isolator only when the top plate ("A") has risen just above the shim ("E").
10. Remove all spacer shims ("E").
11. Fine adjust isolators to level equipment.
12. Adjust all limit stop lock nuts ("F") per isolator, maintaining 0.25-to 0.375-inch gap. The limit stop nuts must be kept at this gap to ensure uniform bolt loading during uplift (as the case when equipment is drained).

This Page Left Intentionally Blank

UNIT OPERATION

GENERAL DESCRIPTION

The units are designed to work independently, or in conjunction with other equipment via a YORK ISN building management system or other automated control system. When operating, the unit controls monitor the chilled liquid system temperatures at the unit and take the appropriate action to maintain the temperatures within desired limits. This action will involve running one or more compressors to match the cooling effect of the refrigerating systems to the heat load on the liquid system. The heat removed from the chilled liquid is then rejected from the air cooled condenser coils.

The following sections give an overview of the operation of the unit. For detailed information, reference should be made to the MBCS Operating Instructions for the unit.

START-UP

Check the main power supplies to the unit are 'ON', all refrigerant service valves are open (anti-clockwise one turn short of fully open) and chilled liquid flow has been established (unless the unit chilled liquid pump start control is being used, in which case just ensure the pump supply is on). Ensure that the system switches under the 'OPTIONS' key are in the 'ON' position.

Press the 'STATUS' key on the keypad and then switch the unit 'ON/OFF' switch below the keypad to the 'ON' position.

The controller will perform a pre-check to ensure that the daily/holiday schedule and any remote interlocks will allow the unit to run, all safety cut-outs are satisfied and that cooling load is required (i.e. that the chilled liquid temperature is outside the set limits). Any problems found by the pre-check will be displayed if present. If no problems are present and cooling duty is required the lead compressor will start. The display will show the anti-coincidence timer status for the lag compressor.

NORMAL RUNNING AND CYCLING

Once the unit has been started, all operations are fully automatic. After an initial period of operation with the lead compressor, the control system will adjust the unit load depending on the chilled liquid temperature and rate of temperature change. If high heat load is present, the controller will increase the capacity of the unit and start-up the next compressor.

If very little heat load is present, the lead compressor may continue to operate or may simply stop again to avoid overcooling the liquid. If the latter is the case, one compressor will restart automatically should the liquid temperature rise again.

When a compressor is running the controller monitors oil pressure, motor current, and various other system parameters such as discharge pressure, chilled liquid temperature, etc. Should any problems occur, the control system will immediately take appropriate action and display the nature of the fault (see MBCS Manual).

SHUTDOWN

The unit can be stopped at any time by switching the unit 'ON/OFF' switch just below the keypad to the 'OFF' position. The compressor heaters will energise to prevent refrigerant condensing in the compressor rotors and to prevent the compressor oil becoming saturated with refrigerant.

To prevent damage to the unit the control supply to the compressor heaters should not be switched off, even when the unit is not required to run.

If mains power must be switched off, (for extended maintenance or a shutdown period), the compressor suction, discharge and liquid line service valves on both systems should be closed (clockwise) and if there is a possibility of liquid freezing due to low ambient temperatures, the cooler and condenser should be drained. The valves should be opened, the cooler and condenser refilled and the power must be switched on for at least 8 hours before the unit is restarted.

This Page Left Intentionally Blank

MAINTENANCE

GENERAL REQUIREMENTS

The units have been designed to operate continuously provided they are regularly maintained and operated within the limitations given in this manual. Each unit should be included in a routine schedule of daily maintenance checks by the operator/customer, backed up by regular service inspection and maintenance visits by a suitably qualified Service Engineer.

It is entirely the responsibility of the owner to provide for these regular maintenance requirements and/or enter into a maintenance agreement with a Johnson Controls service organisation to protect the operation of the unit. If damage or a system failure occurs due to improper maintenance during the warranty period, Johnson Controls shall not be liable for costs incurred to return the unit to satisfactory condition.

This maintenance section applies to the basic unit only and may, on individual contracts, be supplemented by additional requirements to cover any modifications or ancillary equipment as applicable.

The Safety Section of this manual should be read carefully before attempting any maintenance operations on the unit. This section should be read in conjunction with the Section 7.

DAILY MAINTENANCE

The following maintenance checks should be carried out on a daily basis by the operator/customer. Please note that the units are not generally user serviceable and no attempt should be made to rectify faults or problems found during daily checks unless competent and equipped to do so. If in any doubt, contact your local Johnson Controls Service Centre.

Unit status: Press the 'STATUS' key on the keypad and ensure no fault messages are displayed (refer to the MBCS Manual for explanation of messages and the Trouble Shooting section for courses of action).

Operating conditions: Read the operating pressures and temperatures at the control panel using the 'OPER DATA' key and check that these are within the operating limitations given in the MBCS Manual.

Refrigerant leaks: Visually check the cooler, condenser, compressors and pipework for damage and gas leaks.

Compressor oil level: Check the compressor oil level when the compressor is operating normally. The oil level should be between the $\frac{1}{2}$ and $\frac{3}{4}$ in the oil sight glass.

At shutdown the oil level can fall to the lower limit of the oil sight glass.

Compressor Oil Quality: The oil used in the compressors is pale in colour. If the oil colour darkens or exhibits a change in colour, this may be an indication of contaminants in the refrigerant system. If this occurs, an oil sample should be taken and analysed. If contaminants are present, the system must be cleaned to prevent compressor failure.

Refrigerant Charge: When a system starts up, or sometimes after a change of capacity, a flow of bubbles will be seen in the liquid line sight glass. After a few minutes of stable operation, the bubbles should clear leaving just liquid refrigerant showing in the sight glass.

In addition to the checks listed above, periodic inspections of the unit should be carried out to ensure proper equipment operation. Items such as loose equipment, component operation, unusual noises, etc. should be investigated and corrected immediately.

SCHEDULED MAINTENANCE

The maintenance operations detailed in the following table should be carried out on a regular basis by a suitably qualified Service Engineer. It should be noted that the interval necessary between each 'minor' and 'major' service can vary depending on, for instance, application, site conditions and expected operating schedule. Normally a 'minor' service should be carried out every three to six months and a 'major' service once a year. It is recommended that your local Johnson Controls Service Centre is contacted for recommendations for individual sites.

SERVICE SCHEDULE	MINOR SERVICE	MAJOR SERVICE All items under Minor Service plus:
Unit general:	Check thermal insulation. Check vibration isolators.	Check main structure. Check paint-work.
Refrigerant systems general:	Check relief valves. Check for pipework damage. Check for leaks. Check moisture indicator. Check suction superheat. Check liquid subcooling.	Check solenoid valves.
Compressors:	Check oil level. Check condition of oil.	
Evaporator/Condenser:	Check water flow. Check water pressure drop. Check heater mats.	Check water pH / glycol strength.
Power & Control system general:	Check panel condition. Check mains and control wiring. Check sensor locations. Check mechanical HP cut-outs.	Check all connections. Check compressor contactors. Check sensor / transducer calibration. Check motor protectors. Check contactor contacts.
Microprocessor controls:	Check fault history. Check program settings. Check HP / LP cut-out function's. Check pump-down function. Check load / unload function.	Check ambient cut-out function.

Evaporator/Condenser In-Service Inspection

There is no corrosion on the refrigerant side therefore in-service inspection on the refrigerant side is not necessary.

For the water side, if the water used is treated in accordance with Section 4, in-service inspection is not necessary. In the design of the vessels used in the unit, a 1 mm corrosion allowance has been used to consider slight corrosion on the water side. This allowance is sufficient to cover the lifetime of the unit.

Johnson Controls believes that periodic in service proof testing (e.g.; hydro tests) is not required. However, Johnson Controls recognises that national regulations may require such testing to be conducted.

TROUBLE SHOOTING

Competent Persons Trouble Shooting Guide

PROBLEM	POSSIBLE CAUSE	ACTION
No display on panel — Unit will not operate	<p>Mains supply to unit off.</p> <p>Emergency stop device off.</p> <p>No supply to -T1.</p> <p>No 24 Vac supply to microprocessor board.</p> <p>No 24 Vac output from Transformer -T1.</p> <p>Short circuit in wiring to temperature sensors or pressure transducers.</p> <p>Defective microprocessor board or display board.</p>	<p>Switch on mains supply if safe to do so.</p> <p>Check if remote emergency stop device is in the 'OFF' position. Turn to 'ON' position if safe to do so.</p> <p>Check wiring to -T1 and fuse -F1.</p> <p>Check wiring from -T1 to microprocessor board.</p> <p>Replace -T1.</p> <p>Unplug connections at microprocessor board to isolate.</p> <p>Replace board after contacting YORK Service.</p>
FLOW SWITCH / REM STOP NO RUN PERMISSIVE displayed	<p>No liquid flow through the cooler.</p> <p>Flow switch contacts are not made.</p> <p>Defective flow switch.</p> <p>Remote cycling device open.</p>	<p>Ensure that liquid pumps are running. Valves are correctly set and flow is established.</p> <p>Check the flow switch is functional and is installed according to the manufacturers instructions.</p> <p>Note: On some systems the pump starter may be wired to the unit and controlled to start by the unit.</p> <p>Replace flow switch.</p> <p>Check cycling devices connected to terminals 13 and 14 on the EEV Interface PCB terminal block.</p>
UNIT FAULT: LOW AMBIENT TEMP displayed	Incorrect Low Ambient Mode Settings.	Set Ambient Control Type to 'Low Ambient Mode' and Set Low Ambient Cutout to -17.8°C.
UNIT FAULT: LOW LIQUID TEMP displayed	<p>Improperly adjusted leaving chilled liquid temperature cut-out (glycol only).</p> <p>Control panel setpoint/range values improperly programmed.</p> <p>Chilled liquid flow too low.</p> <p>Defective -BLCT or -BECT sensor. (Check the sensor is properly installed in the bottom of the well with a generous amount of heat conductive compound).</p>	<p>Re-program the leaving chilled liquid temperature cut-out.</p> <p>Re-adjust setpoint/range.</p> <p>Increase chilled liquid flow.</p> <p>Compare sensor against a known good temperature sensing device. Refer to sensor calibration tables.</p>
UNIT FAULT: 115 VAC UNDERVOLTAGE displayed	Poor mains supply voltage.	<p>Check mains supply is stable and within allowable limits.</p> <p>Check for voltage dip on compressor start.</p>

PROBLEM	POSSIBLE CAUSE	ACTION
SYS X HIGH DSCH PRES displayed	Discharge pressure cut-out incorrectly set. Air in refrigerant system. Excessive refrigerant charge. Measured pressure is incorrect.	Adjust in accordance with recommended setting. Check for non-condensables (air) in system. Evacuate and recharge system. Remove refrigerant. Check discharge transducer calibration and wiring.
SYS X LOW SUCT PRESS displayed	Suction pressure cut-out incorrectly set. Faulty expansion valve. Reduced cooler performance. Low refrigerant charge. Restricted refrigerant flow. Measured pressure incorrect.	Adjust in accordance with recommended setting. Replace valve Check for restricted chilled liquid flow. Check for fouled tube surfaces. Check for leaks. Check for blocked filter/drier. Check -YLLSV is operating correctly Check for moisture in the system. Check suction pressure transducer calibration/pressure switch and wiring.
SYS X MP/HPCO FAULT displayed	Compressor internal motor protector (MP) open. External overload tripped. -FHP switch open. Defective -FHP switch. Defective -K1 relay.	Verify refrigerant charge is not low. Verify superheat setting of 5.6° - 8.3°C. Verify correct compressor rotation. Verify compressor is not over loaded. Determine cause and reset. See 'High Discharge Pressure Fault'. Replace -FHP switch. Replace relay.
Compressor(s) do not start	Demand not sufficient. Defective water temperature sensor. Contactor/Overload failure. Compressor failure.	No problem. Compare the display with a thermometer. Should be within +/- 2 degrees. Refer to BECT/ BLCT calibration charts. Replace defective part. Diagnose cause of failure and replace.
Lack of cooling effect	Fouled cooler surface. (Low suction pressure will be observed). Improper flow through the cooler Low refrigerant charge. (Low suction pressure will be observed).	Contact the local YORK service representative. Reduce flow to within unit design specification. Check subcooling and add charge as needed. Check for leaks.
!! LOW BATTERY !! CHECK PROG / SETP / OPTN displayed	RTC battery (U17) flat.	Replace U17 and reprogram setpoints, values, options, time and schedule.

Sensor Calibration Charts**Leaving Liquid Temperature (-BLLT)**

Temperature °C	Resistance ohms	Microboard Voltage Vdc	Sensor Voltage Vdc
-8	14896	1.57	3.43
-6	13388	1.69	3.31
-4	12047	1.81	3.19
-2	10856	1.93	3.07
0	9795	2.05	2.95
2	8849	2.17	2.83
4	8005	2.30	2.70
6	7251	2.42	2.58
8	6575	2.54	2.46
10	5970	2.66	2.34
12	5427	2.78	2.22
14	4937	2.90	2.10

Red wire = 5 V, Black wire = Signal

Test points :

Leaving Liquid Temperature (-BLCT)

Sensor Voltage Input 5V -AMB J6-8/5
Microboard Voltage Input 0V -AMB J6-8/2

Entering Liquid Temperature (-BECT)

Sensor Voltage Input 5V -AMB J6-7/4
Microboard Voltage Input 0V -AMB J6-4/1

Discharge Pressure (-BDP) and Suction (-BSP) Transducers

0 - 400 PSI Transducer		0 - 600 PSI Transducer	
Pressure barg	Voltage Vdc	Pressure barg	Voltage Vdc
0	0.5	0	0.5
50	1.0	75	1.0
100	1.5	150	1.5
150	2.0	225	2.0
200	2.5	300	2.5
250	3.0	375	3.0
300	3.4	450	3.4
350	4.0	525	4.0
400	4.5	600	4.5

Red wire = 5 V, Black wire = 0 V, White wire = signal

Test points :

Discharge Pressure (-BDP) 0 - 600 PSI Transducer:

Refrigerant Circuit 1 -AMB J7-11/7
Refrigerant Circuit 2 -AMB J9-11/9

Voltage = (Pressure (barg) X 0.145) + 0.5

Suction Pressure (-BSP) 0 - 400 PSI Transducer:

Refrigerant Circuit 1 -AMB J7-10/9
Refrigerant Circuit 2 -AMB J9-10/9

0 - 400 PSI Transducer Voltage = (Pressure (PSI) X 0.02) + 0.5

0 - 600 PSI Transducer Voltage = (Pressure (PSI) X 0.01) + 0.5

This Page Left Intentionally Blank

SPARE PARTS

RECOMMENDED SPARES

It is recommended that the common spare parts listed below are held for preventative of corrective maintenance operations.

Details of unit spare parts are given in the Renewal Parts List 035-21977-000. Contact your local Johnson Controls Sales and Service Centre for information and please quote the unit model number and serial number.

Description	Item	Part Number
Pressure Transducer 400psi	-BSP	025-41756-002
Pressure Transducer 600psi	-BDP	025-41756-003
Sensor, Temperature	LWT	025-40273-009
Sensor, Temperature	EWT	025-40273-010
Switch, High Pressure - Manual Reset		025-42135-000
Switch, High Pressure - Internal Reset		025-42136-000

RECOMMENDED COMPRESSOR OIL

The correct type of oil must be used in the unit as shown on the unit data plate and labels. Standard units use the following oil:

Refrigerant	Compressor Oil
R410A	York grade V

ASSOCIATED DRAWINGS

Wiring Diagrams	
Models	YCWL/YCRL SE/HE
Schematic	035-21499-201 & 035-21499-202
Connection	035-21499-203 & 035-21499-204
Legend/Notes	035-21499-205
Models	YCWL/YCRL SE/HE with Soft Start
Connection/Schematic	035-21499-206
Models	YCWL/YCRL SE/HE with EEV
Schematic	035-21499-207
Connection	035-21499-208

This Page Left Intentionally Blank

DECOMMISSIONING. DISMANTLING AND DISPOSAL



Never release refrigerant to the atmosphere when emptying the refrigerating circuits. Suitable retrieval equipment must be used. If reclaimed refrigerant cannot be reused. It must be returned to the manufacturer.



Never discard used compressor oil, as it contains refrigerant in solution. Return used oil to the oil manufacturer.

Unless otherwise indicated, the operations described below can be performed by any properly trained maintenance technician.

GENERAL

Isolate all sources of electrical supply to the unit including any control system supplies switched by the unit. Ensure that all points of isolation are secured in the 'OFF' position. The supply cables may then be disconnected and removed. For connection points refer to Section 4.

Remove all refrigerant from each system of the unit into a suitable container using a refrigerant reclaim or recovery unit. This refrigerant may then be re-used, if appropriate, or returned to the manufacturer for disposal. Under NO circumstances should refrigerant be vented to atmosphere. Drain the refrigerant oil from each system into a suitable container and dispose of according to local laws and regulations governing the disposal of oily wastes. Any spilt oil should be mopped up and similarly disposed of.

Isolate the unit heat exchanger from the external water systems and drain the heat exchanger section of the system. If no isolation valves are installed it may be necessary to drain the complete system.



If glycol or similar solutions have been used in the water system, or chemical additives are contained, the solution **MUST** be disposed of in a suitable and safe manner. Under **NO** circumstances should any system containing glycol or similar solutions be drained directly into domestic waste or natural water systems.

After draining, the water pipework may be disconnected and removed.

Packaged units can generally be removed in one piece after disconnection as above. Any fixing down bolts should be removed and then the unit should be lifted from position using the points provided and equipment of adequate lifting capacity.

Reference should be made to Section 4 for unit installation instructions, Section 9 for unit weights and Section 3 for handling.

Units which cannot be removed in one piece after disconnection as above must be dismantled in position. Special care should be taken regarding the weight and handling of each component. Where possible units should be dismantled in the reverse order of installation.



Residual refrigerant oil and glycol or similar solutions may remain in some parts of the system. These should be mopped up and disposed of as described above.

It is important to ensure that whilst components are being removed the remaining parts are supported in a safe manner.



Only use lifting equipment of adequate capacity.

After removal from position the unit parts may be disposed of according to local laws and regulations.

This Page Left Intentionally Blank



www.johnsoncontrols.com