



Water Cooled Water Chillers, Water-to-Water Reverse Cycle Heat Pumps.

Models CWP / CWP-HP 02 to 35
with HCFC 22 and HFC 407C

F

GB



IMW 910.2M/12.01
Supersedes : IMW 910.1E/01.00

Wesper[®]

Table of Contents

Introduction	p. 3
Safety Precautions	p. 3
General	p. 4
Physical Data	p. 4
Electrical Data	p. 6
Dimensional Data	p. 7
Installation	p. 9
Unit Handling	p. 9
Unit Placement	p. 9
Service Access	p. 9
Vibration Isolators	p. 9
Water Piping	p. 10
Flow Switch	p. 10
Refrigerant Charge	p. 11
Glycol Solution	p. 11
Operating Limits	p. 11
Evaporator Water Pressure Drop Curves	p. 12
Condenser Water Pressure Drop Curves	p. 13
Controls	p. 14
Field Wiring	p. 15
Start-up	p. 18
Maintenance	p. 19
Spare Parts List	p.20
In-Warranty Return Material Procedure	p. 21
Service and Spare Parts Order	p. 21
Troubleshooting Chart	p. 22
Check List	p. 23

1 - Introduction

The purpose of this manual is to provide the installation, start-up, operating and maintenance rules to the users of water cooled water chillers and water-to-water reverse cycle heat pumps.

It does not give a full description of all maintenance works assuring the long life and reliability of this type of equipment. Only the services of qualified personnel, member of a registered maintenance company, can guarantee a reliable and durable running of the machine.

2 - Safety Precautions

Before installing the unit, please read the following safety precautions carefully.



Warning

Installation and maintenance must be performed by qualified personnels who are familiar with local codes and regulations and experienced with this type of equipment.



Caution

Avoid access of non qualified and non authorized persons at the chiller installation site.



Warning

All field wiring must be installed in accordance with the national wiring regulations.



Caution

It is forbidden to undertake any work on electrical components of the unit before disconnecting the power supply.



Warning

Ensure that power supply available for the unit corresponds to the name plate before carrying out the wiring as per the diagram supplied with the unit.



Caution

It is forbidden to undertake any work on electrical components of the unit, if there is presence of water and humidity.



Warning

The unit must be GROUNDED to prevent possible hazards due to insulation failures.



Caution

All works on piping and components of refrigerant circuit under pressure must be only performed by authorized and qualified persons.



Warning

All wiring must not touch the hot refrigerant piping or compressors.



Caution

When undertaking water connection, make sure that any foreign matters will not be introduced into water piping.



Warning

Confirm the unit is switched OFF before installing or servicing the unit.



Caution

Handling of the unit must be done by using the systems designed to support its weight.



Caution

Strainer must be placed in the water lines just prior to the inlets of the water pump and heat exchangers.

3 - General

3.1 - Description

The cooling only and heat pump chillers 02 to 35 are designed for indoor installations.

Each unit consists of hermetic compressor(s), insulated plate type evaporator, plate type condenser (condenser is insulated on heat pump models), refrigerant piping and electrical control panel including all safety and operating controls necessary for dependable automatic operation.

Refrigerant piping includes filter-drier, sight glass with moisture indicator, thermal expansion valve and compressor discharge non-return valves (on size 25 to 35 only). The heat pump models have, in addition, reverse cycle 4-port valve, non-return valves and liquid reservoir.

Each unit is completely assembled, factory wired and charged with oil and refrigerant. Before shipping, the units

are carefully checked and tested, with pure water having positive temperature, in accordance with normal operating conditions.

3.2 - Inspection

Check all items carefully against the bill of lading to insure a complete shipment. Inspect all units for damage upon arrival. Report shipping damage and file a claim with the carrier.

Check the unit name plate before unloading the unit to make certain it agrees with the power supply available.

The constructor is not responsible for physical damage after the unit leaves the factory.

4 - Physical Data

Cooling only models		02	03	04	05	06	07	09
Nominal cooling capacity (1) - HCFC 22	kW	7.9	9.6	13.9	17	20.5	29.1	35
Nominal power input (1) - HCFC 22	kW	1.94	2.35	3.32	3.86	5	7.06	8.64
Nominal cooling capacity (1) - HFC 407C	kW	7.6	9.2	13.3	16.3	19.7	28	33.7
Nominal power input (1) - HFC 407C	kW	1.97	2.38	3.37	3.91	5.08	7.16	8.76
Number of refrigerant circuit		1	1	1	1	1	1	1
Refrigerant charge HCFC 22 / HFC 407C	kg	1.45/1.45	1.6/1.6	1.75/1.75	2.0/2.0	2.7/2.7	2.8/2.8	3.0/3.0
Compressor								
Type / Number		Scroll / 1	Scroll / 1	Scroll / 1	Scroll / 1	Scroll / 1	Scroll / 1	Scroll / 1
No of capacity reduction steps (standard)	#	1	1	1	1	1	1	1
Evaporator								
Number / Water volume	dm ³	1 / 0.7	1 / 1.1	1 / 1.1	1 / 1.7	1 / 1.7	1 / 2.2	1 / 2.2
Inlet water connection (male threaded)		1"1/4	1"1/4	1"1/4	1"1/4	1"1/4	1"1/4	1"1/4
Outlet water connection (male threaded)		1"1/4	1"1/4	1"1/4	1"1/4	1"1/4	1"1/4	1"1/4
Condenser								
Number / Water volume	dm ³	1 / 0.7	1 / 0.7	1 / 1.1	1 / 1.1	1 / 1.7	1 / 1.7	1 / 2.2
Inlet water connection (male threaded)		1"1/4	1"1/4	1"1/4	1"1/4	1"1/4	1"1/4	1"1/4
Outlet water connection (male threaded)		1"1/4	1"1/4	1"1/4	1"1/4	1"1/4	1"1/4	1"1/4
Dimensions and weight								
Length	mm	800	800	800	800	900	900	900
Depth with support feet	mm	600	600	600	600	700	700	700
Height with support feet	mm	910	910	910	910	910	910	910
Shipping weight	kg	115	119	125	138	185	197	201
Operating weight	kg	116	120	127	140	188	200	205

(1) Data based on chilled water temperatures of 12 / 7 °C and condenser water temperatures of 29 / 35 °C.

4 - Physical Data (cont'd)

Cooling only models		15	18	21	25	30	35
Nominal cooling capacity (1) - HCFC 22	kW	42.3	55	64.9	86.1	-	-
Nominal power input (1) - HCFC 22	kW	10.7	14.6	18.7	21.4	-	-
Nominal cooling capacity (1) - HFC 407C	kW	40.7	53	62.3	83	104.7	126.1
Nominal power input (1) - HFC 407C	kW	10.9	14.8	19	21.8	29.6	38.1
Number of refrigerant circuit		1	1	1	1	1	1
Refrigerant charge HCFC 22 / HFC 407C	kg	4.3/4.3	4.5/4.5	5/5	8.5/8.5	9/9	11.2/11.2
Compressor							
Type / Number		Scroll / 1	Recip. / 1	Recip. / 1	Scroll / 2	Recip. / 2	Recip. / 2
No of capacity reduction steps (standard)	#	1	1	1	2	2	2
Evaporator							
Number / Water volume	dm ³	1 / 2.8	1 / 4.4	1 / 5.3	1 / 6.9	1 / 8.6	1 / 10.9
Inlet water connection (male threaded)		1"1/2	1"1/2	1"1/2	2"	2"	2"
Outlet water connection (male threaded)		1"1/2	1"1/2	1"1/2	2"	2"	2"
Condenser							
Number / Water volume	dm ³	1 / 2.8	1 / 4.4	1 / 5.3	1 / 6.9	1 / 8.6	1 / 10.9
Inlet water connection (male threaded)		1"1/2	1"1/2	1"1/2	2"	2"	2"
Outlet water connection (male threaded)		1"1/2	1"1/2	1"1/2	2"	2"	2"
Dimensions and weight							
Length	mm	1100	1100	1100	1700	1700	1700
Depth with support feet	mm	850	850	850	984	984	984
Height with support feet	mm	1110	1110	1110	1210	1210	1210
Shipping weight	kg	270	286	299	503	524	561
Operating weight	kg	274	291	305	511	535	575

(1) Data based on chilled water temperatures of 12 / 7 °C and condenser water temperatures of 29 / 35 °C.

Heat pump models		02	03	04	05	06	07	09
Nominal heating capacity (1) - HCFC 22	kW	9.3	11.1	16.3	19.7	24.2	34.5	41.7
Nominal power input (1) - HCFC 22	kW	2.54	2.93	4.26	4.99	6.41	9.07	11.02
Nominal heating capacity (1) - HFC 407C	kW	9.0	10.7	15.7	19.0	23.3	33.2	40.1
Nominal power input (1) - HFC 407C	kW	2.58	2.97	4.33	5.06	6.51	9.21	11.20
Nominal cooling capacity (1) - HCFC 22	kW	6.8	8.2	12	14.7	17.8	25.3	30.6
Nominal power input (1) - HCFC 22	kW	2.54	2.93	4.26	4.99	6.41	9.07	11.02
Nominal cooling capacity (1) - HFC 407C	kW	6.5	7.9	11.5	14.2	17.1	24.4	29.4
Nominal power input (1) - HFC 407C	kW	2.58	2.97	4.33	5.06	6.51	9.21	11.20
Number of refrigerant circuit		1	1	1	1	1	1	1
Refrigerant charge HCFC 22 / HFC 407C	kg	4/4	4.4/4.4	4.4/4.4	4.5/4.5	5.5/5.5	5.5/5.5	5.6/5.6
Compressor								
Type / Number		Scroll / 1	Scroll / 1	Scroll / 1	Scroll / 1	Scroll / 1	Scroll / 1	Scroll / 1
No of capacity reduction steps (standard)	#	1	1	1	1	1	1	1
Evaporator								
Number / Water volume	dm ³	1 / 0.7	1 / 1.1	1 / 1.1	1 / 1.7	1 / 1.7	1 / 2.2	1 / 2.2
Inlet water connection (male threaded)		1"1/4	1"1/4	1"1/4	1"1/4	1"1/4	1"1/4	1"1/4
Outlet water connection (male threaded)		1"1/4	1"1/4	1"1/4	1"1/4	1"1/4	1"1/4	1"1/4
Condenser								
Number / Water volume	dm ³	1 / 0.7	1 / 1.1	1 / 1.1	1 / 1.7	1 / 1.7	1 / 2.2	1 / 2.2
Inlet water connection (male threaded)		1"1/4	1"1/4	1"1/4	1"1/4	1"1/4	1"1/4	1"1/4
Outlet water connection (male threaded)		1"1/4	1"1/4	1"1/4	1"1/4	1"1/4	1"1/4	1"1/4
Dimensions and weight								
Length	mm	800	800	800	800	900	900	900
Depth with support feet	mm	600	600	600	600	700	700	700
Height with support feet	mm	910	910	910	910	910	910	910
Shipping weight	kg	127	130	137	151	204	216	222
Operating weight	kg	128	132	139	154	207	220	226

(1) Data based on chilled water temperatures of 12 / 7 °C and condenser water temperatures of 40/46 °C.

4 - Physical Data (cont'd)

Heat pump models		15	18	21	25	30	35
Nominal heating capacity (1) - HCFC 22	kW	51.1	62.9	76.2	104.1	125.3	154.4
Nominal power input (1) - HCFC 22	kW	13.7	16.3	20.5	28.4	32.4	41.3
Nominal heating capacity (1) - HFC 407C	kW	49.1	60.4	73.3	100.3	120.5	148.4
Nominal power input (1) - HFC 407C	kW	13.9	16.5	20.8	28.8	32.9	41.9
Nominal cooling capacity (1) - HCFC 22	kW	37.3	46.5	55.7	75.7	92.7	113
Nominal power input (1) - HCFC 22	kW	13.7	16.3	20.5	28.4	32.4	41.3
Nominal cooling capacity (1) - HFC 407C	kW	35.9	44.8	53.5	72.9	89.2	108.5
Nominal power input (1) - HFC 407C	kW	13.9	16.5	20.8	28.8	32.9	41.9
Number of refrigerant circuit		1	1	1	1	1	1
Refrigerant charge HCFC 22 / HFC 407C	kg	8.5/8.5	9.4/9.4	15/15	16/16	17/17	19/19
Compressor							
Type / Number		Scroll / 1	Recip. / 1	Recip. / 1	Scroll / 2	Recip. / 2	Recip. / 2
No of capacity reduction steps (standard)	#	1	1	1	2	2	2
Evaporator							
Number / Water volume	dm ³	1 / 2.8	1 / 4.4	1 / 5.3	1 / 6.9	1 / 8.6	1 / 10.9
Inlet water connection (male threaded)		1"1/2	1"1/2	1"1/2	2"	2"	2"
Outlet water connection (male threaded)		1"1/2	1"1/2	1"1/2	2"	2"	2"
Condenser							
Number / Water volume	dm ³	1 / 2.8	1 / 4.4	1 / 5.3	1 / 6.9	1 / 8.6	1 / 10.9
Inlet water connection (male threaded)		1"1/2	1"1/2	1"1/2	2"	2"	2"
Outlet water connection (male threaded)		1"1/2	1"1/2	1"1/2	2"	2"	2"
Dimensions and weight							
Length	mm	1100	1100	1100	1700	1700	1700
Depth with support feet	mm	850	850	850	984	984	984
Height with support feet	mm	1110	1110	1110	1210	1210	1210
Shipping weight	kg	298	315	330	503	524	561
Operating weight	kg	302	320	336	511	535	575

(1) Data based on chilled water temperatures of 12 / 7 °C and condenser water temperatures of 40/46 °C.

5 - Electrical Data - HCFC 22 & HFC 407C

Cooling only and Heat pump models		02	03	04	05	06	07	09
Standard supply voltage (V / Ph / Hz)		230/1/50	400/3/50 + Neutral + Ground					
Maximum current	A	17.3	6.5	9.7	11.3	14.7	20.0	24.5
Nominal current *	A	9.1	4.4	7.1	7.2	10.5	14.1	15.8
Maximum starting current	A	76	46	66	74	99	127	167

Cooling only and Heat pump models		15	18	21	25	30	35
Standard supply voltage (V / Ph / Hz)		400/3/50 + Neutral + Ground					
Maximum current	A	29	40	48	58	80	96
Nominal current *	A	19.3	26.4	33.4	38.5	52.8	66.8
Maximum starting current	A	198	180	200	227	220	248

Notes : - Tolerance on supply voltage : $\pm 10\%$.
 - Currents are given for a standard voltage.
 * Chilled water : 12 / 7 °C - hot water : 29 / 35 °C.

6 - Dimensional Data

Cooling only and Heat pump 02 to 21

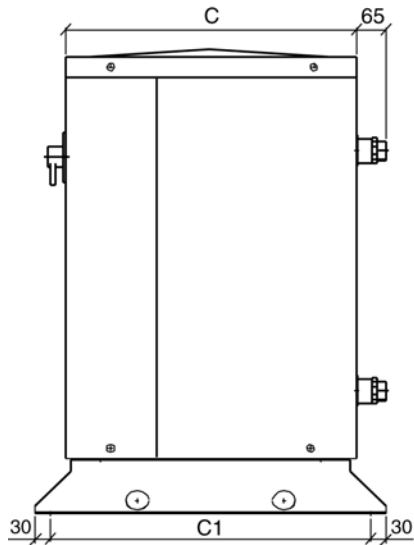

Side view

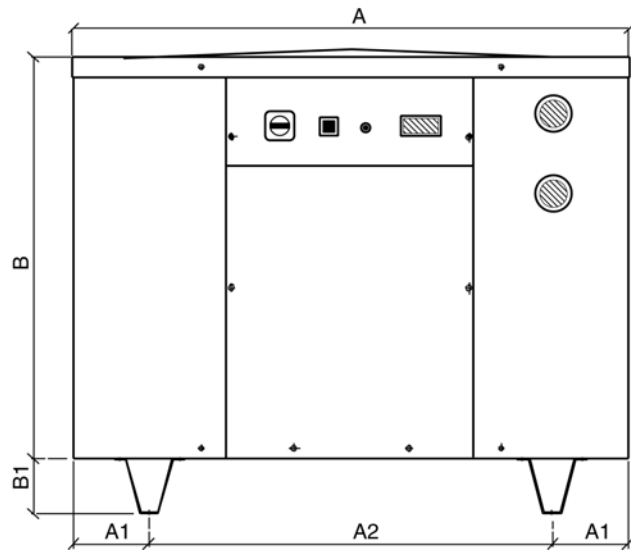

Front view

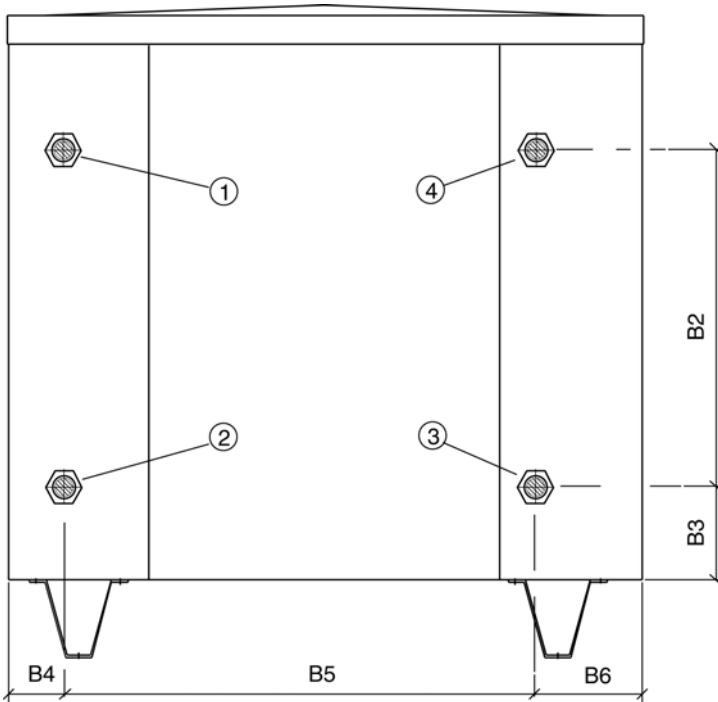

Rear view

- ① **Evaporator inlet** : 1"1/4 male (sizes 02 to 09) or 1"1/2 male (sizes 15 to 21)
- ② **Evaporator outlet** : 1"1/4 male (sizes 02 to 09) or 1"1/2 male (sizes 15 to 21)
- ③ **Condenser inlet** : 1"1/4 male (sizes 02 to 09) or 1"1/2 male (sizes 15 to 21)
- ④ **Condenser outlet** : 1"1/4 male (sizes 02 to 09) or 1"1/2 male (sizes 15 to 21)

For **heat pump** models, make provision for a flow switch per water circuit and water connections must be made as follows :

- ① **Water return from installation**
- ② **Water leaving to installation**
- ③ **External source water outlet**
- ④ **External source water inlet**

Unit size	A	A1	A2	B	B1	B2	B3	B4	B5	B6	C	C1
02 to 05	800	75	650	900	110	478	135	80	567	153	480	540
06 to 09	900	100	700	900	110	478	135	80	667	153	580	640
15 to 21	1100	150	800	1000	110	518	145	100	800	200	730	790

Dimensions in mm.

6 - Dimensional Data (cont'd)

Cooling only and Heat pump 25 to 35

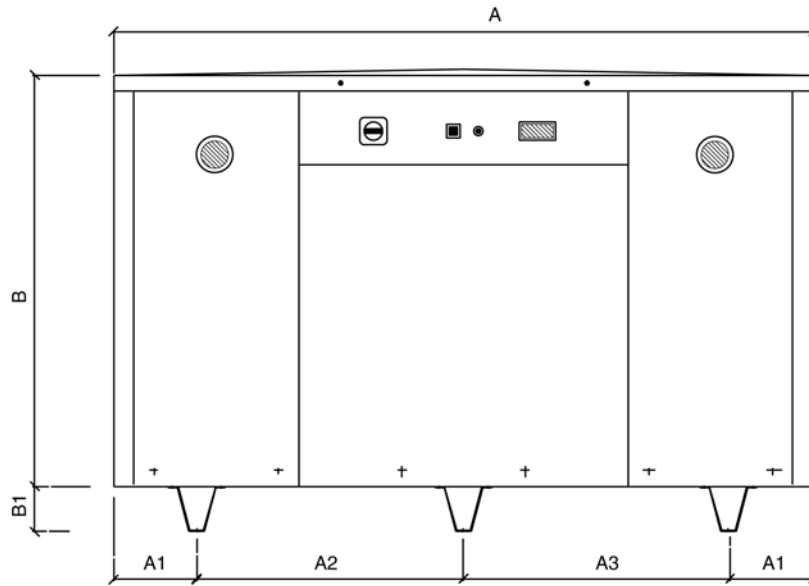

Front view

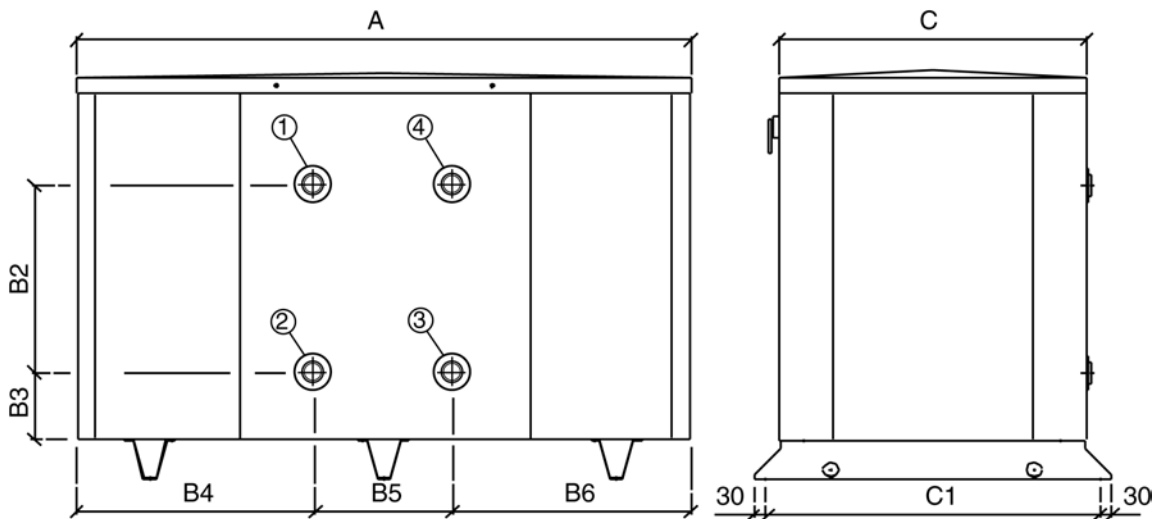

Rear view

Side view

- | | |
|--|--|
| <p>① Evaporator inlet : 2" male</p> <p>② Evaporator outlet : 2" male</p> | <p>③ Condenser inlet : 2" male</p> <p>④ Condenser outlet : 2" male</p> |
|--|--|

For **heat pump** models, make provision for a flow switch per water circuit and water connections must be made as follows :

- | | |
|--|--|
| <p>① External source water inlet</p> <p>② External source water outlet</p> | <p>③ Water leaving to installation</p> <p>④ Water return from installation</p> |
|--|--|

Unit size	A	A1	A2	A3	B	B1	B2	B3	B4	B5	B6	C	C1
25 to 35	1700	200	650	650	1100	110	518	145	660	380	660	850	924

Dimensions in mm.

7 - Installation

7.1 - Unit Handling

Warning

Sharp edges are a potential injury hazard. Avoid contact with them.

Be careful to avoid rough handling of the unit. Do not push or pull the unit anything other than the base. Block the pushing vehicle away from the unit to prevent damage to the sheet metal cabinet and end frame (see Figure 1).

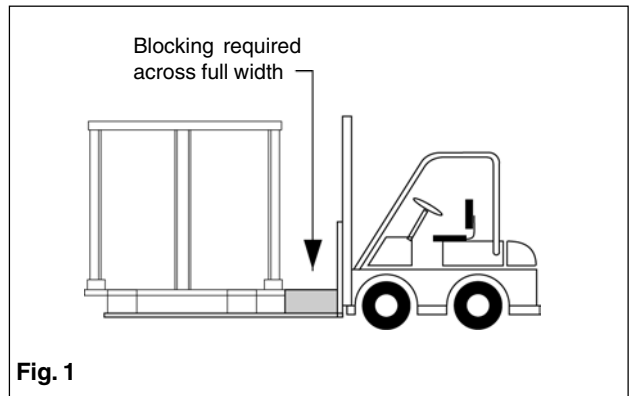

7.2 - Unit Placement

Unit designed for indoor applications and must be located in an area protected from bad weathers and kept out of freezing during winter. The area must be clean, dry and correctly ventilated.

Install the unit with enough side clearance for servicing. Provide service access to the evaporator, condenser, compressor, electrical control panel and piping components as shown in Figure 2.

7.3 - Service Access

All safety and operating controls are accessible from the

electrical control box side being the front side of the unit.

The compressors, evaporator, condenser, refrigerant piping and water piping are accessible from the back side, after removing the access panel.

7.4 - Vibration Isolators

Vibration isolators are recommended for all roof mounted installations or wherever vibration transmission is a consideration (see chapter "Dimensional Data" for the location of each isolator).

Vibration eliminators in all water piping connected to the units are recommended to avoid straining the piping and transmitting vibration and noise.

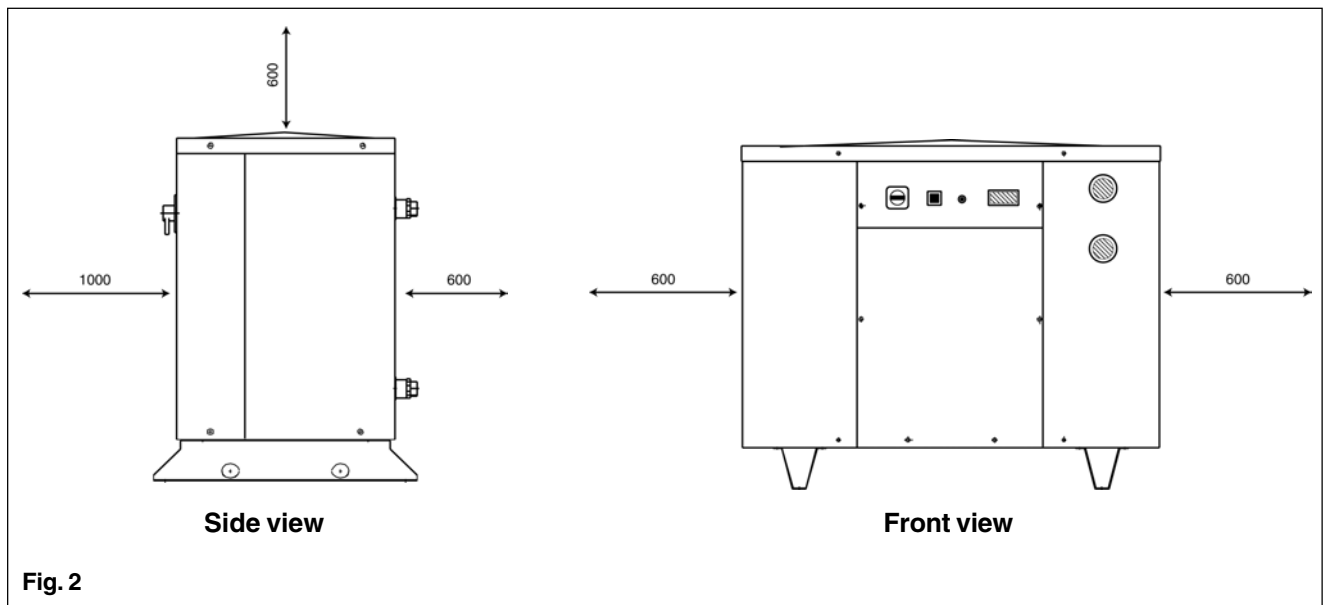

7 - Installation (cont'd)

7.5 - Water Piping

Local authorities can supply the installer with the proper building and safety codes required for safe and proper installation.

Install piping with minimum bends and changes in elevation to minimize pressure drop. Consider the following when installing water piping:

1. All piping should be installed and supported to prevent the unit connections from bearing any strain or weight of the system piping.
2. Vibration eliminators to reduce vibration and noise transmission to the building. Check the free volume expansion of the connection piping.
3. Shut-off valves to isolate the unit from the piping system during unit servicing.
4. Manual or automatic air vent valves at the highest points of the chilled water piping.
5. Some means of maintaining adequate system water pressure (expansion tank or regulating valve).
6. Temperature and pressure indicators located at the inlet and outlet of the heat exchangers to aid in unit servicing.
7. A strainer or other means of removing foreign matter from the water before it enters the pump and heat exchangers is recommended. Place the strainer far enough upstream to prevent cavitation at the pump inlet (consult pump manufacturer for recommendations).
8. Each evaporator and condenser (heat pump models only) have a heating cable and a thermostat to prevent freeze-up down to -18°C .

Caution

During winter shut-down periods, it is recommended to either keep the unit energized or supply the heating cable with a separate 230 V source, although the heating cable is factory wired to the control circuit.

Caution

If separate disconnect is used for the 230 V supply to the heat exchanger heating cable, mark the disconnect clearly to ensure disconnect is not accidentally shut off during cold seasons.

Caution

It is not our policy to make recommendations on water treatment. The general contractor or owner should contact a local water treatment company regarding water treatment. However, this topic is critical and care should be taken to make sure it is done properly to prevent problems related to flow. A fouled water system will lead to premature component failure.

Caution

Water connections could be damaged by an important stress when screwing them. Use a second spanner to compensate the stress of tightening.

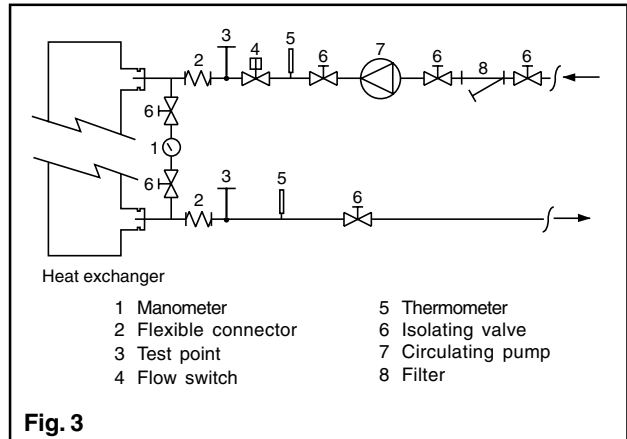

Fig. 3

Although the heat exchangers are equipped with freeze protection, it does not protect water piping external to the unit or protect the heat exchangers in the event of a power failure or heater cable burnout.

To obtain additional freeze protection, it is recommended to drain the heat exchangers and chilled water piping if the unit will not be operated during winter and to add a glycol solution with an adequate % of glycol to the chilled water system to further protect the system during low ambient periods (temperature lower than $+1^{\circ}\text{C}$).

Note : a water flow switch or pressure differential switch must be mounted in the water lines to the heat exchangers assuring water flow before starting the unit.

7.6 - Flow Switch

A water flow switch must be installed on the heat exchanger water inlet piping to ensure that there is sufficient water flow and cooling load in the heat exchanger when the unit is started. This will protect the compressor against any eventual liquid slugging during start-up and prevent accidental freeze-up when water flow is interrupted.

The flow switch is available as an option. It is a "paddle" type switch and adaptable to any pipe.

Installation should be as shown in Figure 4. Connect the normally open contacts of the flow switch to the terminals provided in the unit control center (See wiring diagram supplied with the unit). There is also a set of normally closed contacts on the switch that can be used for an indicator light or an alarm to indicate when a "no flow" condition exists. Freeze protect any flow switch that is installed outdoors.

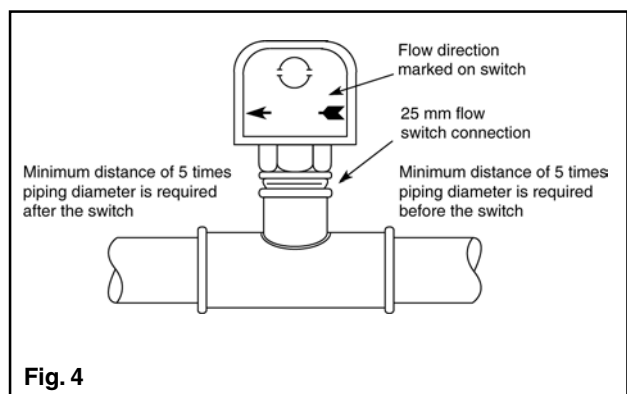

Fig. 4

7 - Installation (cont'd)

7.7 - Refrigerant Charge

All units are designed for use with HCFC 22 and HFC 407C. See nameplate for specific refrigerant used. Units are shipped with an operating charge.

7.8 - Glycol Solution

The use of ethylene glycol to prevent the heat exchangers and the system water piping from freezing, will affect the unit performance. Use the following correction factors for units utilizing glycol solution.

For glycol solution higher than 20 %, it is highly recommended to consult your glycol supplier for recommendations.

Ethylene glycol correction factors

% ethylene glycol by weight	10	20	30	40	50
Amb. air (C)	-3	-8	-14	-22	-33
Cooling capacity	0.991	0.982	0.972	0.961	0.946
Power input	0.996	0.992	0.986	0.976	0.966
Water flow rate	1.013	1.040	1.074	1.121	1.178
Water pressure drop	1.070	1.129	1.181	1.263	1.308

Example: protect the unit against freezing for ambient temperature down to -8 °C.

- Determine ethylene glycol concentration: 20%.
- Find corrected cooling capacity by multiplying the chiller's capacity (kW) by capacity correction factor 0.982.
- Determine corrected water flow rate:

$$l/s = \frac{\text{Corrected cooling capacity} \times 860}{\text{Delta T} \times 3600}$$

Corrected water flow rate = l/s x correction factor (1.04).

- Determine water pressure drop through evaporator, when using glycol: read the pressure drop (from evaporator water pressure drop curve) corresponding to the corrected water flow rate and multiply this pressure drop by correction factor (1.129).

Note : The effect of glycol in the condenser is negligible. As glycol increases in temperature, its characteristics have a tendency to mirror those of water. Therefore, for selection purposes, there is no derate in capacity for the glycol in the condenser.

7.9 - Operating Limits

Heat exchanger pressures

Unit size	Max. operating pressure (bar)		Test pressure (bar)	
	Water side	Refrig. side	Water side	Refrig. side
02 to 35	10.5	13.0	14.0	26.0

Water temperatures - All units

All units	Min. (C)	Max. (C)
Leaving chilled water temp. (1)	6	15
Chilled water delta T (2)	4	6
Condenser leaving water temp.	26	51
Condenser water delta T (2)	5	7
Cond. entering water temp. (3)	20	45
Cond. entering water temp. (4)	15	36

(1) Without glycol.

(2) For operating limits, refer to heat exchanger WPD curves.

(3) For units without pressostatic valve.

(4) For units with pressostatic valve.

Important: For all air conditioning installation with a chilled water distribution, it is necessary that the whole distribution system must be sized to restore a volume of **15 liters/kW** of which the cooling capacity to be considered corresponds to the minimum step of capacity reduction of the machine. In some cases, it will be necessary to add a storage capacity and an expansion tank on the going or the return of the chilled water piping system.

8 - Evaporator Water Pressure Drop Curves

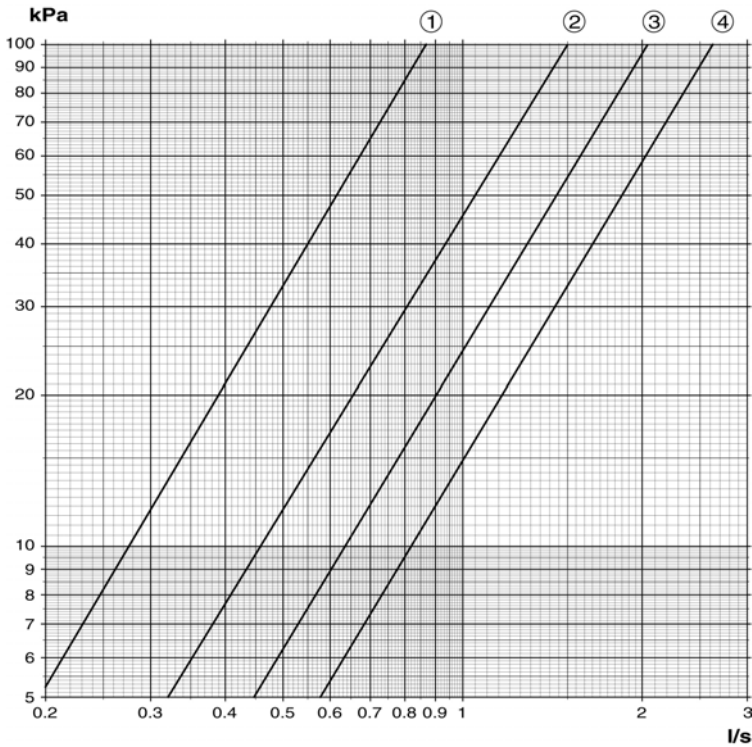

Water flow rate calculation :

$$q_m = \frac{P \times 860}{\Delta t \times 3600}$$

with : q_m water flow in l/s
P capacity in kW
 Δt water delta T in °C

Curve 1 : Cooling only 02 and Heat pump 02
Curve 2 : Cooling only 03 & 04 and Heat pump 03 & 04

Curve 3 : Cooling only 05 & 06 and Heat pump 05 & 06
Curve 4 : Cooling only 07 & 09 and Heat pump 07 & 09

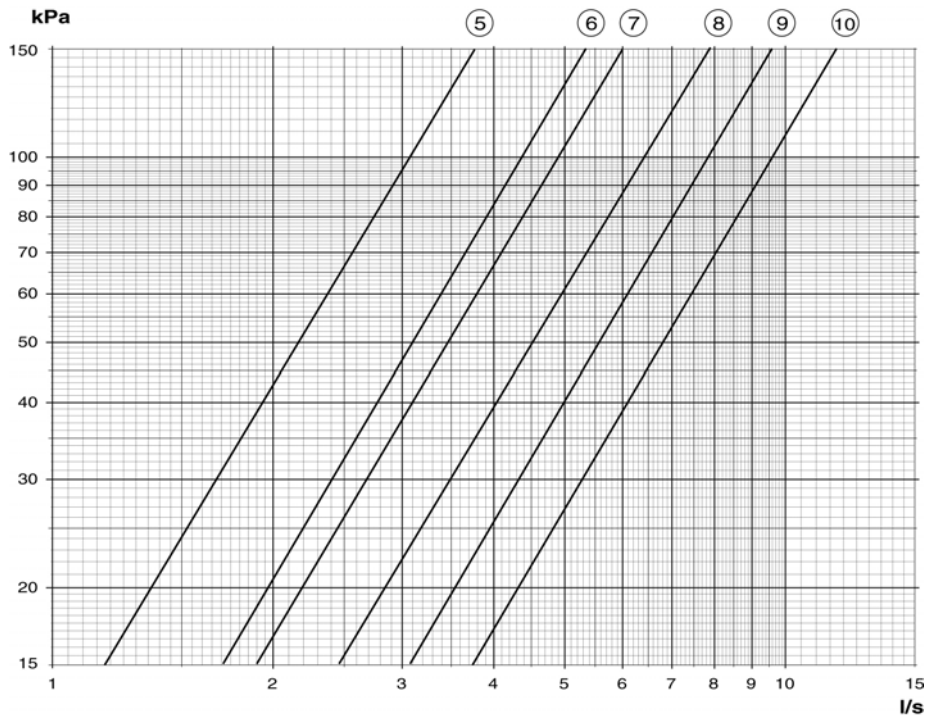

Curve 5 : Cooling only 15 and Heat pump 15
Curve 6 : Cooling only 18 and Heat pump 18
Curve 7 : Cooling only 21 and Heat pump 21

Curve 8 : Cooling only 25 and Heat pump 25
Curve 9 : Cooling only 30 and Heat pump 30
Curve 10 : Cooling only 35 and Heat pump 35

9 - Condenser Water Pressure Drop Curves

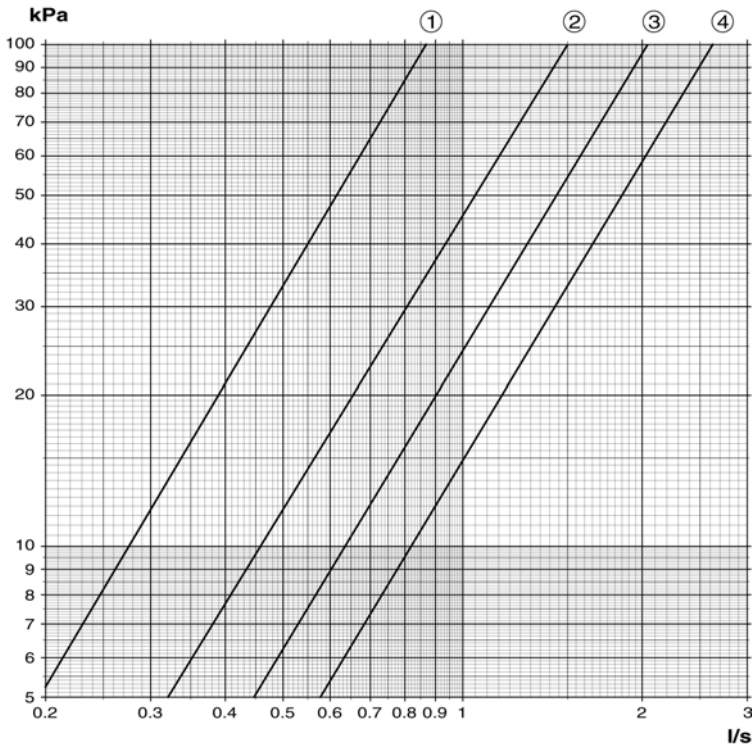

Water flow rate calculation :

$$q_m = \frac{P \times 860}{\Delta t \times 3600}$$

with : q_m water flow in l/s
 P capacity in kW
 Δt water delta T in °C

Curve 1 : Cooling only 02 & 03 and Heat pump 02.
Curve 2 : Cooling only 04 & 05 and Heat pump 03 & 04.

Curve 3 : Cooling only 06 & 07 and Heat pump 05 & 06.
Curve 4 : Cooling only 09 and Heat pump 07 & 09.

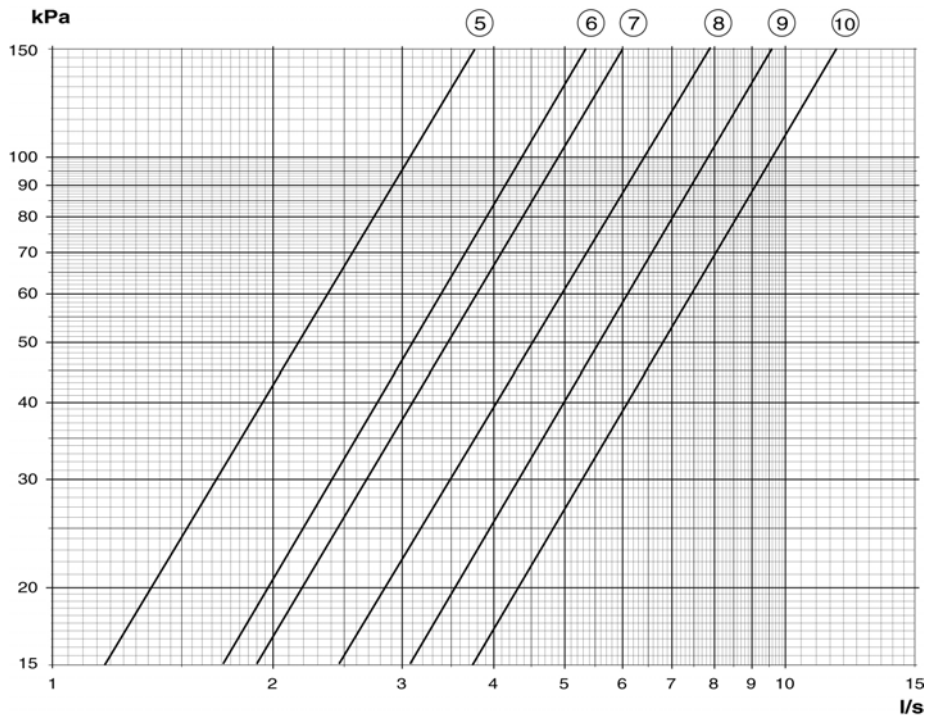

Curve 5 : Cooling only 15 and Heat pump 15.
Curve 6 : Cooling only 18 and Heat pump 18.
Curve 7 : Cooling only 21 and Heat pump 21.

Curve 8 : Cooling only 25 and Heat pump 25.
Curve 9 : Cooling only 30 and Heat pump 30.
Curve 10 : Cooling only 35 and Heat pump 35.

10 - Controls

10.1 - Temperature Controller

The controller fitted on the cooling only and heat pump units 02 to 35 is factory calibrated for operation on return water temperature. For this reason, the controller sensor is located at the evaporator inlet in order to control the system cooling load.

The necessary setting of the controller is the set point adjustment only; this can be adjusted in a setting range from -10 °C to +20 °C. The factory setting is +12 °C for cooling only units. In the case of heat pump units, the controller is set for operation over an adjustable set-point range from +25 to +45 °C (during winter season) and from +10 to +18 °C (during summer season).

If the set points are lower than the factory settings, make sure that glycol solution is used in the system water circuit and that all control and safety devices are adjusted accordingly.

Note: for set points lower than +10 °C (on return water), consult the factory about the precautions to be considered for a good operation of the machine.

10.2 - High Pressure Control

The high pressure control is a pressure activated switch that opens on a rise in pressure. When the switch opens, the safety relay de-energizes the compressor circuit preventing the unit operation until the high pressure control is reset.

The high pressure switch requires manual reset and is factory adjusted to trip out at 27 bar.

10.3 - Low Pressure Control

The low pressure control is a pressure switch activated by evaporator pressure. The switch opens when the pressure decreases abnormally.

The low pressure switch requires manual (cooling only models) and automatic (heat pump models) reset and is factory adjusted to close at 1.7 bar (on cooling only models) and 2.5 bar (on heat pump models).

10.4 - Heat Exchanger Heater Thermostat

The evaporator heater thermostat provides freeze protection down to -18 °C ambient temperature during unit shut down periods.

It closes at +3 °C, activating afterwards the evaporator heating cable.

On heat pump units, both evaporator and condenser are equipped with electric heater cable and thermostat to protect against freezing.

10.5 - Antifreeze Thermostat

The antifreeze electronic thermostat, fitted on cooling only units, prevents the evaporator from freezing up during operation.

The thermostat, manual reset type, is activated when the leaving chilled water temperature is down to +3 °C (other setting for glycol solution, on request).

On heat pump units, both evaporator and condenser are equipped with antifreeze thermostat.

10.6 - Pressostatic Valve Kit (optional)

This item is available only for cooling only units.

The pressostatic valve, controlled by condensing pressure, regulates the water flow to maintain the condensing temperature at the desired value (the condensing temperature of +40 °C is recommended).

11 - Field Wiring

Wiring must be in accordance with all applicable codes and regulations. Warranty is void if wiring does not comply with specifications. A blown fuse indicates a short, ground or overload. Before replacing a fuse or restarting a compressor, find and correct the trouble.

The heat exchanger heater should preferably be energized through a separate disconnect switch from the main unit

power supply, so that the unit can be shut down without defeating the freeze protection provided by the heat exchanger heater.

The remote on/off switch should be wired to terminals as indicated in the wiring diagram supplied with the unit. If this option is not used, "shunt" these both terminals.

The water flow switch must be wired to terminals as shown in the unit wiring diagram.



Caution

Field wiring must be installed according to unit wiring diagram located inside the unit control box.



Caution

Unit must be grounded through terminal provided inside electrical panel.



Caution

Use only copper wire for all power lead terminations at the unit. Aluminium or copper can be used for all other wiring. Wiring must be sized in accordance with the IEC Codes.



Caution

The supply voltage must not vary more than 10 %. the unbalance between the phases must not exceed 3 %.

ALWAYS REFER TO THE UNIT WIRING DIAGRAM LOCATED INSIDE THE ELECTRICAL PANEL

11 - Field Wiring (cont'd)

Example of wiring diagram for single compressor cooling only units - control circuit

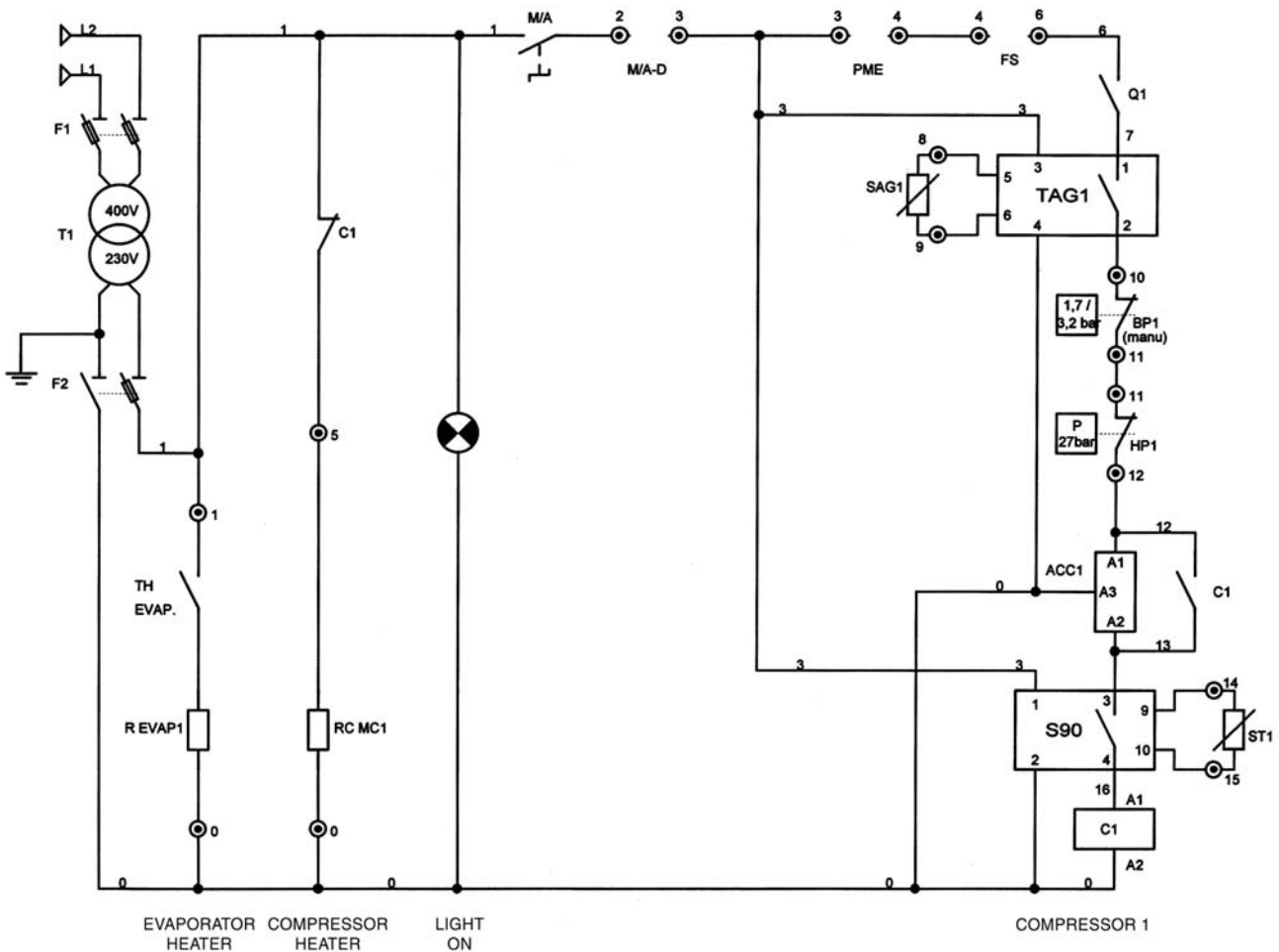

USER JUNCTION BLOCK

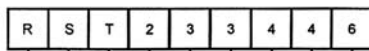

ALIM TRI M/A-D PME FS
400V 50HZ

CONSTRUCTOR JUNCTION BLOCK

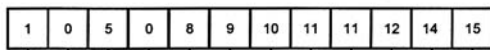

R EVAP1 RC MC1 SAG1 BP1 HP1 ST1

Legend :

- F1, F2 Fuses
- T1 Transformer
- TH EVAP Evaporator heater thermostat
- R EVAP1 Evaporator heater
- RC MC1 Compressor crankcase heater
- M/A On/Off switch
- M/A-D Remote On/Off switch
- PME Safety pressure switch for lack of water detection
- FS Flow switch
- SAG1 Anti-freeze sensor
- TAG1 Anti-freeze thermostat
- BP1 Low pressure switch
- HP1 High pressure switch
- ACC1 Anti-short cycle relay
- S90 Temperature controller
- ST1 Temperature sensor
- C1 Compressor contactor
- ALIM TRI 3-phase power supply

11 - Field Wiring (cont'd)

Example of wiring diagram for single compressor heat pump units - control circuit

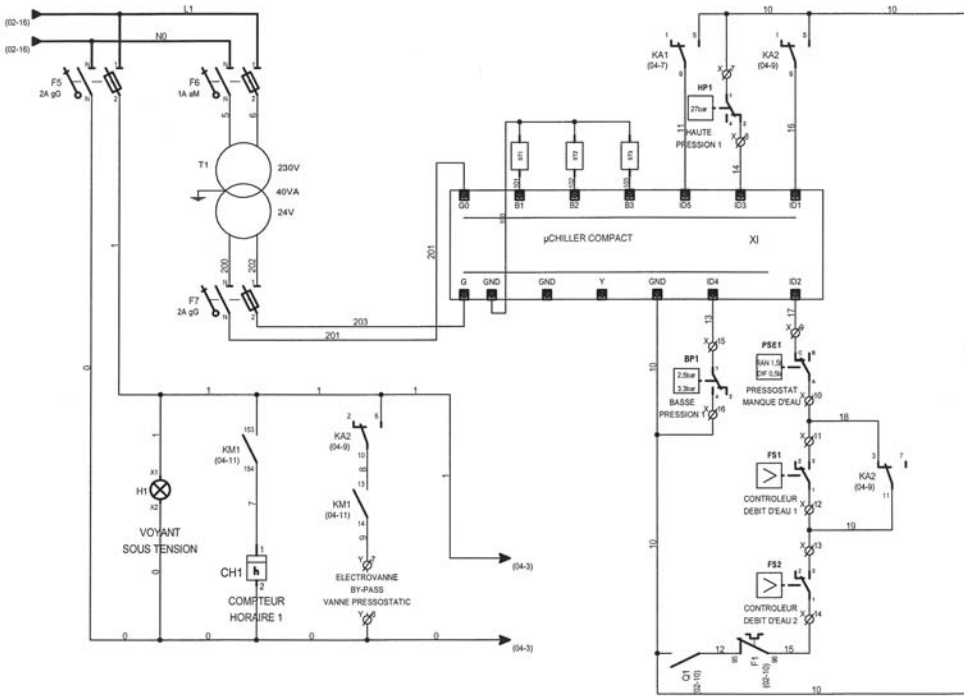

Legend :

- F5, F6, F7 Fuses
- T1 Transformateur
- μCHILLER COMPACT : Controller
- ST1, ST2, ST3 : Temperature sensors
- HP1 High pressure switch
- H1 Indicator light
- CH1 Hour meter
- BP1 Low pressure switch
- PSE1 Safety pressure switch for lack of water detection
- FS1, FS2 Flow switches
- TH1, TH2 Evaporator heater thermostat 1 & 2
- R EVAP1 Evaporator heater 1
- R EVAP2 Evaporator heater 2
- S1 On/Off switch
- S2 Winter/Summer switch
- V4V1 4-way valve

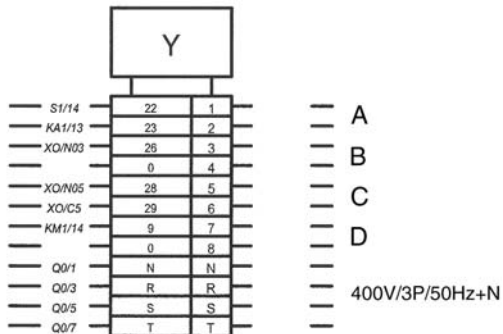
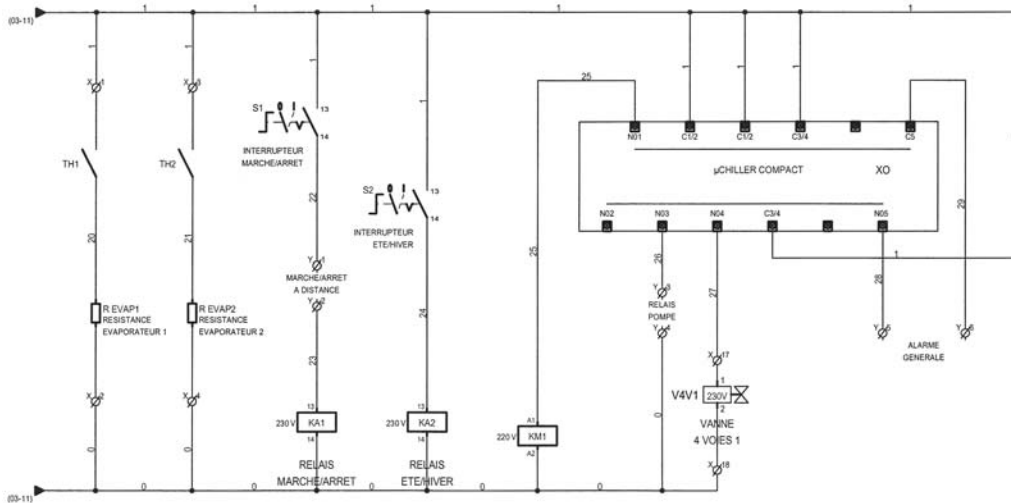

User junction block

- A Remote On/Off
- B Pump relay
- C Main alarm
- D Electrovalve bypassing pressostatic valve

12 - Start-up

12.1 - Pre Start-up

Before starting up the unit, a certain number of verifications must be performed on the installation to ensure that the unit will operate under the best possible conditions. The check list below is not exhaustive and should only be used as a minimum reference basis.

1. Inspect all water piping for flow direction and correct connections at the heat exchangers.
2. Verify all system piping is correct for operation as per installation requirements.
3. Verify minimum cooling load equal or above 60 % of maximum load is available at the start-up.
4. Check voltage of the unit power supply and make certain voltage is within authorized limitations.
5. Make sure unit is properly grounded.
6. **Check the presence of water flow safety devices.**
7. **Make sure unit operation is electrically interlocked with water pumps operation. Any failure of these pumps or lack of water flow in the evaporator and condenser must inevitably shut the compressor down. The non compliance with this procedure will result in suppression of the unit warranty. Refer to wiring diagram for this electrical interlock.**
8. Check all electric connections for tightness.
9. Open all water flow valves and start the water pumps (please refer to constructor's manual for pump startup). Make certain water flow rate complies with installation requirements.
10. Check all piping for leaks and vent the air from the heat exchangers as well as from the system piping before starting the compressor. Flush the heat exchangers and system piping to obtain clean, non corrosive water in the heat exchangers .
11. Supply power to the unit, after having checked that the unit on/off switch is in "OFF" position. Wait at least 2 hours before starting the unit, to ensure crankcase is heated.

12.2 - Start-up

1. On heat pump units, make sure that summer/winter switch is on the desired position.
2. Move on/off switch to "ON" position. On a call for cooling or heating, the compressors will start after a period of 6 minutes (time delay of anti-short cycle relays).

3. Check then the good condition of operation of all control and safety devices of the unit (chilled water temperature controller, high pressure switch and antifreeze thermostat).
4. Check that electrical interlock, assuring compressor shut down when there is no water flow in the evaporator and condenser, is correctly done.

12.3 - Unit Operation

Cooling only models

During the unit operation, the "OUT" symbol of temperature control thermostat and the "ON" symbol of antifreeze thermostat are fed.

When the chilled water set point temperature is satisfied, the "OUT" symbol (sizes 02 to 21) or "DIRECT" symbol (sizes 25 to 35) is turned off and the unit is shut down.

The compressor is protected by a set of electric and refrigerant safety devices. The safety shutdown of the unit will be provoked by the cutoff of one of these protective devices or by the cutoff of antifreeze thermostat materialized by lighting of its "OFF" symbol. This condition remains unchanged as long as the failure detected will not be manually eliminated.

Heat pump models

During the unit operation, the controller display, the compressor light and the "Sun" symbol (cooling mode) or the "Snow" symbol (heating mode) are fed.

When the chilled water or hot water set point temperature is satisfied, the "Sun" symbol or the "Snow" symbol is turned off and the unit is shut down.

The compressors are protected by a set of electric and refrigerant safety devices. The safety shutdown of the unit will be provoked by the cutoff of one of these protective devices or by the cutoff of antifreeze thermostat materialized by lighting of its "OFF" symbol. This condition remains unchanged as long as the failure detected will not be manually eliminated.

The safety shutdown of the unit can be materialized by an optional remote fault relay.

All these safety devices are to be reset (manually) only after having detected the failure and eliminated it.

Each compressor is fitted with an electronic anti-short cycle relay which imposes a compressor minimum shut down time between two start-ups. This **6 minute** time delay is engaged as soon as the compressor is turned off.

13 - Maintenance

Maintenance on this equipment are to be performed by qualified personnel. Causes for repeated tripping of safety controls must be investigated and corrected.

The units are designed to operate for long periods of time with a minimum of maintenance. However, certain preventive maintenance operations must be performed at least every **six months** and after any extended shut down period (cold period).

These operations are mostly routine checks such as **inspection of set points and cutoff points, inspection of voltages and currents, inspection of water flow rates and temperatures, etc.**

Extended Shutdown

The following recommendations may be considered for extended shutdown of unit:

- After the compressors have pumped down, turn off the water pump(s).
- Disconnect all electrical power supply to the unit and to the water pump(s).
- If glycol is not used in the system, drain all water from the unit heat exchangers and water piping, if the unit is to be shut down during winter.

Electrical Terminals

Retighten all power electrical terminals every **six months**.

Evaporator and Condenser

No particular maintenance is required for these heat exchangers, but **it is mandatory to install a strainer (with mesh lower than 1 mm) on the inlet of evaporator water piping to prevent foreign matters from entering and clogging the heat exchangers.**

No mechanical cleaning operation is possible on plate-to-plate type heat exchangers. Clean them with detergents for fatty deposits. For heavier fouling, use chemicals compatible with copper like formic, citric, vinegar or other organic acids. Never wait until the unit is heavily fouled before cleaning.



Warning

Disconnect all power before doing any service inside the unit.

Sight Glass / Moisture Indicator

Visually check refrigerant sight glass at least once a month. Bubbling refrigerant in the sight glass indicates the unit is short of refrigerant charge. Refrigerant gas flashing in the sight glass could also indicate an excessive pressure drop in the line, possible due to a clogged filter-drier or a restriction elsewhere in the refrigerant circuit. In this case, have the installation checked by qualified personnel.

The sight glass has a humidity sensitive element that indicates the level of humidity in the circuit through a colour reference of the element.

Thermal Expansion Valve

The expansion valve allows the proper amount of refrigerant to enter the evaporator (regardless of cooling load) by maintaining a constant superheat (superheat is the difference between refrigerant temperature as it leaves the evaporator and the saturation temperature corresponding to the evaporator pressure).

All units are factory set for an average value of superheat from 4 to 7 K. In case of problem, the setting must be performed only by qualified personnel.

Reverse cycle 4-way valve (Heat pump models)

The 4-way valve allows the cycle reversal for the operation in heating mode (hot water production) and in cooling mode (chilled water production). This valve is factory calibrated and wired; it does not require any particular maintenance.

14 - Spare Parts List

Common parts, All sizes	Code
Sensor well	SOF000005
High pressure switch	R2PHPR036
Low pressure switch	R2PBPR044
Antifreeze thermostat	R1TSEC130
Temperature sensor	R2SSDE033
Safety pressure switch for detection of lack of water	R2PBPE043
Pressostatic valve, 1/2"	R3PVPR008
Pressostatic valve, 3/4"	R3PVPR009
Pressostatic valve, 1"	R3PVPR010
Pressostatic valve, 1" 1/4	R3PVPR011

Common parts, All sizes	Code
Water filter, 33/42	F2FFAT021
Water filter, 40/49	F2FFAT022
Water filter, 50/60	F2FFAT023
Isolating valves (2 nos), 33/42	F1RBTV082
Isolating valves (2 nos), 40/49	F1RBTV084
Isolating valves (2 nos), 50/60	F1RBTV083
High pressure gauge	R7MCAD064
Low pressure gauge	R7MCAD065
Water flow switch	R7CCLQ015

Cooling only/Heat pump models	02	03	04	05	06	07	09
Cooling only model condenser	F4DEVP033	F4DEVP021	F4DEVP021	F4DEVP021	F4DEVP022	F4DEVP022	F4DEVP023
Heat pump model condenser kit	S1FE00002	S1FE00003	S1FE00003	S1FE00005	S1FE00005	S1FE00009	S1FE00009
Thermal expansion valve	R4DTHE051	R4DTHE051	R4DTHE052	R4DTHE050	R4DTHE047	R4DTHE048	R4DTHE048
Filter-drier	F2DCGS019	F2DCGS016	F2DCGS016	F2DCGS016	F2DCGS016	F2DCGS017	F2DCGS017
Liquid sight glass	F1WVLF133	F1WVLF126	F1WVLF126	F1WVLF126	F1WVLF126	F1WVLF127	F1WVLF127
Compressor	Y3CPGF079	Y3CPGF080	Y3CPGF081	Y3CPGF082	Y3CPGF100	Y3CPGF101	Y3CPGF102
Temp. controller S90 *	R1TSEC121	R1TSEC121	R1TSEC121	R1TSEC121	R1TSEC121	R1TSEC121	R1TSEC121
Temp. controller chiller compact **	R7TTER073	R7TTER073	R7TTER073	R7TTER073	R7TTER073	R7TTER073	R7TTER073
Evaporator kit	S1FE00002	S1FE00003	S1FE00003	S1FE00005	S1FE00005	S1FE00009	S1FE00009
Reverse cycle 4-way valve	R3PVPR012	R3PVPR012	R3PVPR012	R3PVPR012	R3PVPR013	R3PVPR013	R3PVPR013

Cooling only/Heat pump models	15	18	21	25	30	35
Cooling only model condenser	F4DEVP049	F4DEVP050	F4DEVP045	F4DEVP046	F4DEVP047	F4DEVP048
Heat pump model condenser kit	S1FE00015	S1FE00018	S1FE00021	S1FE00040	S1FE00050	S1FE00070
Thermal expansion valve	R4DTHE048	R4DTHE049	R4DTHE049	R4DTHE055	R4DTHE054	R4DTHE078
Filter-drier	F2DCGS017	F2DCGS017	F2DCGS018	F2DCGS018	F2DCGS020	F2DCGS020
Liquid sight glass	F1WVLF127	F1WVLF127	F1WVLF128	F1WVLF128	F1WVLF135	F1WVLF135
Compressor	Y3CPGF103	Y3CPGF040	Y3CPGF042	Y3CPGF103	Y3CPGF040	Y3CPGF042
Temp. controller S90 *	R1TSEC121	R1TSEC121	R1TSEC121	-	-	-
Temp. controller IR32W *	-	-	-	R1TSEC122	R1TSEC122	R1TSEC122
Temp. controller chiller compact **	R7TTER073	R7TTER073	R7TTER073	-	-	-
Temp. controller chiller - board **	-	-	-	R7TCAR067	R7TCAR067	R7TCAR067
Temp. controller chiller - terminal **	-	-	-	R7TTER066	R7TTER066	R7TTER066
Evaporator kit	S1FE00015	S1FE00018	S1FE00021	S1FE00040	S1FE00050	S1FE00070
Reverse cycle 4-way valve	R3PVPR014	R3PVPR014	R3PVPR016	R3PVPR017	R3PVPR017	R3PVPR017

* For cooling only models.

** For heat pump models.

15 - In-Warranty Return Material Procedure

Material must not be returned without permission of our After Sales Department. To return the material, contact your nearest sales office and ask for a "return voucher". This return voucher shall be sent out with the returned material and shall contain all necessary information concerning the problem encountered. The return of the part does not constitute an order for replacement. Therefore, a purchase order must be entered through our distributor or regional sales office. The order should include part name, part number, model number and serial number of the unit involved.

Following our personal inspection of the returned part, and if it is determined that the failure is due to faulty material or workmanship, and in warranty, credit will be issued on customer's purchase order. All parts shall be returned to the our factory, transportation charges prepaid.

16 - Service and Spare Parts Order

The model number, the confirmation number and the unit serial number indicated on the name plate must be provided whenever service works or spare parts are ordered.

For any spare part order, indicate the date of unit installation and date of failure. If part number is not available, provide full description of the part required. Indicate also whether HCFC 22 or HFC 407C is used.

17 - Troubleshooting Chart

PROBLEM	POSSIBLE CAUSES	POSSIBLE CORRECTIVE STEPS
COMPRESSOR WILL NOT RUN	<ol style="list-style-type: none"> 1. Main switch open 2. Fuse blown, circuit breaker open 3. Thermal relay tripped. 4. Defective contactor or coil 5. System off by safety device 6. No cooling required 7. Liquid line solenoid will not open 8. Motor electrical problem 9. Loose wiring 	<ol style="list-style-type: none"> 1. Close switch. 2. Check electrical circuits and motor windings for shorts. Check for overloads and loose connections. Replace fuse or reset circuit breaker. 3. Reset thermal relay, check unit when back on line. 4. Repair or replace. 5. Determine cause and correct. 6. None, should start on call for cooling. 7. Repair or replace coil. 8. Check motor for open or short circuit, or burnout 9. Check all wire junction. Tighten all terminals.
COMPRESSOR NOISY OR VIBRATING	<ol style="list-style-type: none"> 1. Refrigerant flooding compressor 2. Improper line support 3. Worn compressor 	<ol style="list-style-type: none"> 1. Check expansion valve setting. 2. Relocate or add supports. 3. Replace.
HIGH DISCHARGE PRESSURE	<ol style="list-style-type: none"> 1. Condenser water insufficient or temperature too high 2. Fouled condenser 3. Non condensables in system 4. System overcharge with refrigerant 5. Condenser undersized 	<ol style="list-style-type: none"> 1. Readjust temperature control or water regulating valve. Investigate ways to increase water supply. 2. Clean. 3. Purge the non condensables. 4. Remove excess refrigerant. 5. Check condenser rating tables against the operation.
LOW DISCHARGE PRESSURE	<ol style="list-style-type: none"> 1. Fault condenser temperature control 2. Low refrigerant charge 3. Low suction pressure 4. Condenser too large 	<ol style="list-style-type: none"> 1. Check condenser control operation. 2. Check for leaks. Add refrigerant. 3. See low suction pressure steps below. 4. Check condenser rating tables against the operation.
HIGH SUCTION PRESSURE	<ol style="list-style-type: none"> 1. Excessive load 2. Expansion valve overfeeding 	<ol style="list-style-type: none"> 1. Reduce load or add capacity. 2. Check remote bulb. Regulate superheat. Replace expansion valve.
LOW SUCTION PRESSURE	<ol style="list-style-type: none"> 1. Lack of refrigerant 2. Evaporator dirty 3. Clogged filter-drier 4. Expansion valve malfunctioning 5. Low condensing temperature 6. Compressor will not load 7. Low evaporator water flow 	<ol style="list-style-type: none"> 1. Check for leaks. Repair and replace refrigerant. 2. Clean chemically. 3. Replace it. Check humidity level via sight glass. 4. Check and adjust for proper superheat. 5. Check head pressure control devices. 6. See steps below for correcting failure to unload. 7. Adjust water flow.
COMPRESSOR FULLY LOADS OR FULLY UNLOADS	<ol style="list-style-type: none"> 1. Faulty control thermostat 2. Faulty thermostat staging control 3. Wrong thermostat capacity control setting 4. Worn or broken compressor 	<ol style="list-style-type: none"> 1. Replace. 2. Replace. 3. Modify setting. 4. Replace compressor.
MOTOR THERMAL RELAY OPEN OR BLOWN FUSES	<ol style="list-style-type: none"> 1. Low voltage during high loads 2. Defective or grounded motor wiring 3. Loose power wiring 4. High condensing temperature 5. Unbalanced voltage 6. High temperature inside control box 	<ol style="list-style-type: none"> 1. Check supply voltage. 2. Replace compressor. 3. Check all connections and tighten. 4. See steps for high discharge pressure. 5. Check voltage. Contact power company. 6. Provide ventilation to reduce heat.
COMPRESSOR THERMAL PROTECTION SWITCH OPEN	<ol style="list-style-type: none"> 1. Operating beyond design conditions 2. Faulty anti-short cycle time delay 	<ol style="list-style-type: none"> 1. Add facilities so conditions are within allowable limits. 2. Replace anti-short cycle relay.

18 - Check List

Make a copy of this sheet, fill in it and paste it on access door of electrical panel.

Job name:		Unit references			
Address:		Unit model:			
		Serial number:			
		Order number:			
1	Is the unit damaged? (if yes, state how)				
2	Unit supply voltage	L1 / L2 - R/S	L1 / L3 - R/T	L2 / L3 - S/T	Hz
		V	V	V	50
3	Control circuit supply voltage	V			
4	Have capacitors been installed on the unit power supply?	YES / NO			
5	Capacitor values in KVAR	YES / NO			
6	Is installed power correct? (if not, give details)	YES / NO			
		Nominal conditions		Actual conditions	
7	Chilled water return temperature				
8	Chilled water leaving temperature				
9	Evaporator water pressure drop				
10	Evaporator water flow rate				
11	Ambient air temperature/Condenser leaving water temperature				
12	Ambient air temperature/Condenser entering water temperature				
13	Condenser water pressure drop				
14	Condenser water flow rate				
15	Job site ambient air temperature				
16	Does the flow switch operate correctly?	YES / NO			
17	Have the propeller/centrifugal fan drives been checked?	YES / NO			
18	Do the condenser fans rotate in the correct direction?	YES / NO			
19	Does the unit have a remote control?	YES / NO			
20	If so, this must first shut the unit down, then the chilled water pump(s)	YES / NO			
21	Has the tightness of all electrical connections been checked?	YES / NO			
22	Does oil pressure switch operate correctly?	YES / NO			
23	Have manual resets and thermal overload settings been checked?	YES / NO			
24	Have motor overload device settings been checked?	YES / NO			
25	Has the capacity unloading sequence been checked?	YES / NO			
26	Do liquid line valve and solenoid valve operate correctly?	YES / NO			
27	Have time delay settings been checked?	YES / NO			
28	Were compressor crankcase heaters energized before the unit was started?	YES / NO			
29	Oil level: 1) before startup 2) after startup	1	2	1	2
30	Compressor model number	N 1	N 2	N 3	N 4
31	Compressor serial number				
32	Discharge pressure	bar			
33	Suction pressure	bar			
34	Oil pressure	bar			
35	Discharge line temperature	C			
36	Condensing temperature	C			
37	Liquid line temperature at condenser outlet	C			
38	Sub-cooling	C			
39	Suction line temperature at expansion valve bulb location	C			
40	Suction superheat	°C			
41	Oil sump temperature	°C			
42	Compressor current draw	A			
43	Low pressure switch, opens / closes at	bar			
44	High pressure switch, opens / closes at	bar			
45	Temperature control thermostat set point	C			
46	Antifreeze thermostat set point	bar			
47	Have condenser fan motor current draw values been checked?	A			
48	Compressor running hours after startup	N 1	N 2	N 3	N 4
		Switch-on / Switch-off (bar)			
49	Fan pressure switch set point				
Date of startup:					
By:					
Company:					



With a concern for a constant improvement, our products can be modified without notice. Photos non contractual.

Your distributor :

Wesper®