

S 24 - S 28 - S 35
+ TOUCH CONTROL Ufly BOX integrate

INSTALLATION AND SERVICING MANUAL



<http://www.unicalag.it/prodotti/domestico-50/condensazione-gas/osa/1635/osa-s>



Provisions for proper disposal of the product in accordance with Directive 2002/96/EC

At the end of its life cycle the product must not be disposed of as urban waste. It can be taken to a special recycling centre managed by the local authorities, or to a dealer who offers this service. Separate disposal of a domestic appliance avoids possible negative consequences for the environment and human health deriving from inappropriate waste handling and allows the recovery of the materials of which it is made, in order to obtain significant energy and resource savings.

Attention: this manual contains instructions for the exclusive use of the professionally qualified installer and/or maintenance technician in compliance with current legislation.

The user is NOT qualified to intervene on the boiler.

The manufacturer will not be held liable in case of damage to persons, animals or objects resulting from failure to comply with the instructions contained in the manuals supplied with the boiler.

1	GENERAL INFORMATION	4
1.1	General warnings	4
1.2	Symbols used in the manual	5
1.3	Appropriate use of appliance.....	5
1.4	Information for system manager.....	5
1.5	Safety warnings.....	6
1.6	Technical data plate	7
1.7	Water treatment.....	8
1.8	Boiler antifreeze protection.....	8

2	TECHNICAL FEATURES AND DIMENSIONS	9
2.1	Technical features	9
2.2	Main components view and dimensions.....	9
2.3	Available flow rate / pressure diagram	14
2.4	Operation data.....	15
2.4.1	Data according to directive ErP	15
2.4.2	Caratteristiche del controllo integrato Ufly BOX	15
2.5	General features	15

3	INSTALLATION INSTRUCTIONS	16
3.1	General warnings	16
3.2	Installation standards	16
3.3	Preventive system verification and adjustment operations	16
3.4	Packaging.....	17
3.4	Positioning the boiler	18
3.6	Flue gas exhaust pipe connection.....	19
3.7	Connections	22
3.8	Filling the system.....	23
3.9	Electrical connections.....	24
3.10	Commissioning	26
3.11	Measurement of combustion efficiency during installation	27
3.11.1	Calibration function activation	27
3.11.2	Probes positioning	28
3.12	Burner adjustment.....	29
3.12.1	Combustion adjustment function activation	30
3.12.3	Adaptation of the power to the heating system.....	31

4	MAINTENANCE INSTRUCTIONS	32
4.1	Inspection and maintenance instructions	32
4.1.1	Pannello comandi Ufly BOX	33
4.2	Parameters that can be edited from the control panel	35
4.3	Adaptation of the power to the heating system	38
4.3.1	GAC adjustment	39
4.4	Wiring diagram.....	43
4.5	Error Code.....	44
4.5.1	Filling system.....	47
4.6	Important Note.....	48
4.6.1	Service panel.....	49

1.1 - GENERAL WARNINGS

The instruction booklet is an integral and essential part of the product and must be kept by the user.

Read the warnings contained in this instruction booklet carefully as they provide important guidelines regarding installation, use and maintenance safety.

Keep the booklet with care for further consultation.

Installation and maintenance must be performed in compliance with the standards in force according to the instructions of the manufacturer, up to standard and by personnel qualified and certified in compliance with law.

Systems for the production of domestic hot water MUST be constructed entirely with compliant materials.

By professionally qualified personnel we mean: personnel with specific technical skill in the field of heating system components for civil use, domestic hot water production and maintenance. Personnel must have the qualifications provided for by current legislation.

Incorrect installation or improper maintenance can cause damage to persons, animals or objects for which the manufacturer is not responsible.

Before performing any cleaning or maintenance, disconnect the appliance from the energy mains by acting on the switch of the system and/or through the specific cut-off devices.

Do not obstruct the terminals of the intake/exhaust ducts.

In the event of failure and/or malfunctioning of the appliance, switch it off and do not try to repair it or intervene on it directly. Contact only personnel qualified in compliance with law.

Any repairs must be performed solely by personnel authorised by Unical AG S.p.A., using original spare parts only. Failure to comply with the above can compromise the safety of the boiler and void the warranty.

To guarantee appliance efficiency and its correct operation, yearly maintenance must be performed by qualified personnel.

Should you decide not to use the appliance, parts entailing potential sources of hazard must be made safe.

Before commissioning an appliance that has not been used, wash the domestic hot water production system, making the water flow until it has been fully replaced.

Should the appliance be sold or transferred to a new owner or if you move and leave the appliance, always make sure that the instruction booklet accompanies it in order to be consulted by the new owner and/or installer.

Only original accessories must be used for all appliances with optionals or kits (including electric).

This boiler is intended solely for the use for which it was expressly designed.

Any other use is to be considered improper and therefore dangerous (*).

1.2 - SYMBOLS USED IN THE MANUAL

Pay special attention when reading this manual to the parts marked by the symbols:



DANGER!
Serious danger
to safety
and health



ATTENTION!
Possible dangerous
situation for the product
and the environment



NOTE!
Tips
for the user



NOTE!
For more information
See Technical Info:
from site indicated at pag. 2

1.3 - APPROPRIATE USE OF APPLIANCE



The boiler has been built according to the current level of engineering and acknowledged technical safety rules.

Nonetheless, if improperly used, dangers could arise for the safety and life of the user and other persons or damage to the equipment or other objects.

The appliance is designed to work in heating systems, with hot water circulation, for the production of domestic hot water.

Any other use is considered improper.

Unical AG S.p.A. will not be held liable for any damage resulting from improper use.

Use according to the intended purposes also includes strict compliance with the instructions in this manual.

1.4 - INFORMATION PROVIDED TO THE USER



The user must be instructed concerning the use and operation of his heating system, in particular:

- Deliver these instructions to the user, as well as other documents concerning the appliance inserted in the envelope inside the packaging. **The user must keep this documentation safe for future consultation.**
- Inform the user about the importance of the air vents and the flue gas exhaust system, highlighting their essential features and the absolute prohibition of modifying them.
- Inform the user concerning controlling the system's water pressure as well as operations to restore it.
- Inform the user concerning correct temperature control, control units/thermostats and radiators for saving energy.
- Please note that, in compliance with the standards in force, the inspection and maintenance of the appliance must be carried out in compliance with the regulations and frequency indicated by the manufacturer.
- Should the appliance be sold or transferred to a new owner or if you move and leave the appliance, always make sure that the instruction booklet accompanies it in order to be consulted by the new owner and/or installer.

The manufacturer will not be held liable in the event of damage to persons, animals or objects resulting from failure to comply with the instructions contained in this manual.

1.5 - SAFETY WARNINGS



ATTENTION!

The boiler cannot be used by children.

The boiler can be used by adults and only after having carefully read the user's manual. Children should be supervised to ensure that they do not play or tamper with the device.



ATTENTION!

The appliance must be installed, adjusted and maintained by professionally qualified personnel, in compliance with the standards and provisions in force. Incorrect installation can cause damage to persons, animals and objects for which the manufacturer cannot be held responsible.



DANGER!

NEVER attempt performing maintenance or repairs on the boiler on your own initiative. Any work must be done by professionally qualified personnel. We recommend stipulating a maintenance contract.

Insufficient or irregular maintenance can jeopardise the operating safety of the appliance and cause damage to persons, animals and objects for which the manufacturer cannot be held responsible.



Changes to the parts connected to the appliance (once the appliance installation is complete)

Do not modify the following parts:

- the boiler
- the gas, air, water and electricity supply lines
- the flue gas pipe, the safety valve and the exhaust pipe
- the construction parts which affect the operating safety of the appliance



Attention!

To tighten or loosen the screwed fittings, use only appropriate fixed spanners.

Incompliant use and/or inappropriate tools can cause damage (e.g. water or gas leakage).



ATTENTION!

Indications for propane gas-fired appliances

Make sure that the gas tank has been deaerated before installing the appliance.

For state-of-the-art tank venting, contact the LPG supplier or person qualified in compliance with the law requirement.

If the tank has not been professionally deaerated, ignition problems could arise.

In that case, contact the supplier of the LPG tank.



Smell of gas

Should a smell of gas be perceived, follow these safety guidelines:

- do not turn electric switches on or off
- do not smoke
- do not use the telephone
- close the gas shut-off valve
- air out the area where the gas leakage has occurred
- inform the gas supplier or a company specialised in installation and maintenance of heating systems.



Explosive and easily flammable substances

Do not use or store explosive or easily flammable materials (e.g. petrol, paints, paper) in the room where the appliance is installed.



DANGER!

Do not use the appliance as a supporting base for objects.

In particular, do not place receptacles containing liquids (Bottles, Glasses, Jars or Detergents) on top of the appliance.

If the appliance is installed inside a housing, do not insert or rest other objects inside this housing.

1.6 - TECHNICAL DATA PLATE

The CE marking

certifies the compliance of the equipment with the essential safety requirements defined in the directives and applicable European regulations and that its functioning satisfy applicable technical standards.

The CE marking is affixed to each piece of equipment with an appropriate label.

The CE declaration of conformity issued in accordance with international standards by the manufacturer, is placed in documentation envelope supplied with the product.



The rating plate is placed inside the boiler,
The rating plate **DUPLICATE** is placed under the front casing (lower-right).

Unical				
2				
Model	3			
S.N°	4	PIN	6	
Type	7	NOx	8	
A Heating	Pn	9 kW	Pcond	10 kW
	Qn	11 kW	Adjusted Qn	12 kW
	PMS	13 bar	T max	14 °C
B DHW	Qhw	15 kW	D	16 l/min
	PMW	19 bar	T max	20 °C
ErP	Tp	24 %	Tph	25 %
E Factory setting		D Countries of destination		
27		26	28	
29				
C Electrical Power supply				
30 V	Hz	31 W		
IP class:		32		
1				
Made in Italy				

KEY:

- 1 = CE monitoring body
- 2 = Type of boiler
- 3 = Boiler model
- 4 = Number of stars (directive 92/42 EEC)
- 5 = **(S.N°) Serial Number**
- 6 = P.I.N. Product Identification Number
- 7 = Types of approved flue gas exhaust configurations
- 8 = (NOx) NOx Class

- A = Heating circuit characteristics
- 9 = (Pn) Effective nominal output
- 10 = (Pcond) Effective output in condensation
- 11 = (Qn) Maximum heat output
- 12 = (Adjusted Qn) Adjusted for rated heat output
- 13 = (PMS) Max. heating operating pressure
- 14 = (T max) Max. heating temperature

- B = Domestic hot water circuit characteristics
- 15 = (Qnw) Rated heat output in domestic hot water function (if different to Qn)
- 16 = (D) Specific D.H.W. flow rate according to EN 625 - EN 13203-1
- 19 = (PMW) Max. domestic hot water operating pressure
- 20 = (T max) Max. domestic hot water temperature

- C = Electrical characteristics
- 21 = Electrical power supply
- 22 = Consumption
- 23 = Protection rating

- D = Countries of destination
- 24 = Direct and indirect countries of destination
- 25 = Gas category
- 26 = Supply pressure

- E = Factory settings
- 27 = Adjusted for gas type X
- 28 = Space for national brands

- G = ErP
- 29 = Seasonal space heating energy efficiency
- 30 = Energy efficiency in DHW production mode

1.7 - WATER TREATMENT



The treatment of the supply water allows to prevent inconveniences and maintain the functionality and efficiency of the generator over time.



The ideal water pH in heating systems must be within:

VALUE	MIN	MAX
PH	6.5	8
Hardness [°fr]	9	15



To minimise corrosion, it is crucial to use a corrosion inhibitor; in order for it to work properly, the metal surfaces must be clean.

(see system protection ACCESSORIES sect. in domestic price list)



ATTENTION!
ANY DAMAGE TO THE BOILER CAUSED BY THE FORMATION OF FOULING OR BY CORROSIVE WATER WILL NOT BE COVERED BY THE WARRANTY.



ATTENTION (*) see general warnings 1.1

The heating only models are NOT suitable for the production of water for human consumption according to Ministerial Decree D.M. 174/2004.

1.8 - BOILER ANTIFREEZE PROTECTION (*)

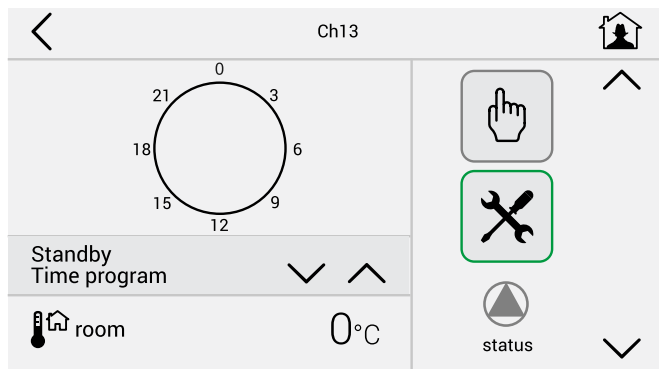

if

If

<

This protection can intervene only if the electricity and gas supplies are connected.

If one of the two is not available and upon reset **11 (SR)** a temperature of 2 °C is detected, the appliance will behave as described in tab. **pos 2**.



The heating system can be protected effectively from frost by using antifreeze products with inhibitor for heating systems (specific for multimetals).

(*) The frost protection is always active. Even disabling the CH and DHW services.

Do not use car engine antifreeze products as they could damage the water gaskets.

POS	ANTIFREEZE FUNCTION				
	Power supplies		11 - SR (*)	Status function antifreeze	Actions
	Electric	Gas			
1	ON	ON	< 6 °C	ON	- Burner and Pump ON until T > 14°C
2	ON	OFF	< 2 °C	ON	Only when both the power supplies are ON: - Burner and Pump OFF until T > 5°C - When T > 5°C then Burner and Pump ON until T > 14°C.
	OFF	ON			
	OFF	OFF			

(*) Sensor 11 par. 2.2

2

TECHNICAL FEATURES AND DIMENSIONS

2.1 - TECHNICAL FEATURES

NOTE!
For more information
See Technical Info
from site indicated at pag. 2

2.2 - VIEW WITH THE INDICATION OF THE MAIN COMPONENTS AND DIMENSIONS

OSA S 24

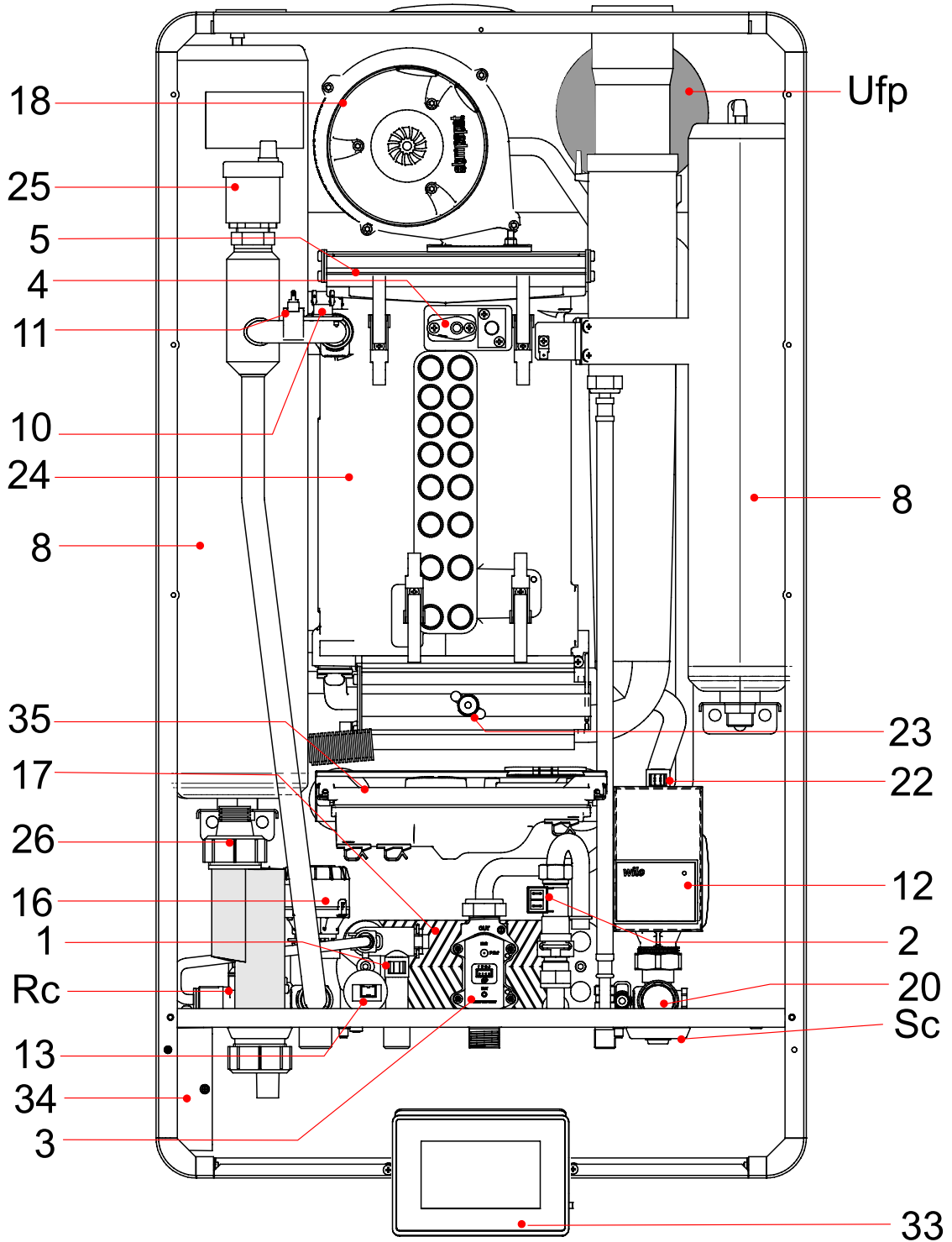

ENGLISH

Technical Features

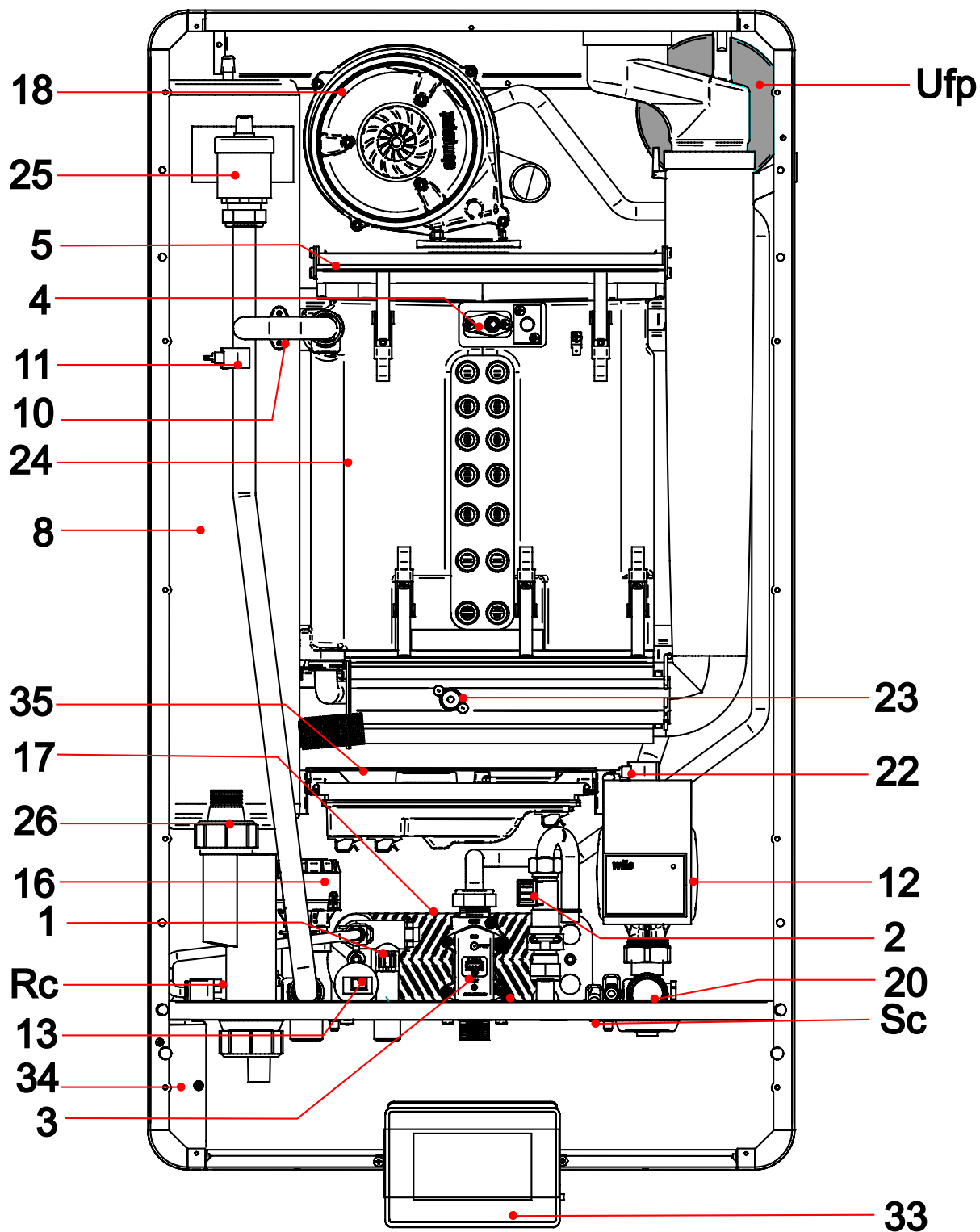

OSA S 24 - OSA S 28 - OSA S 35

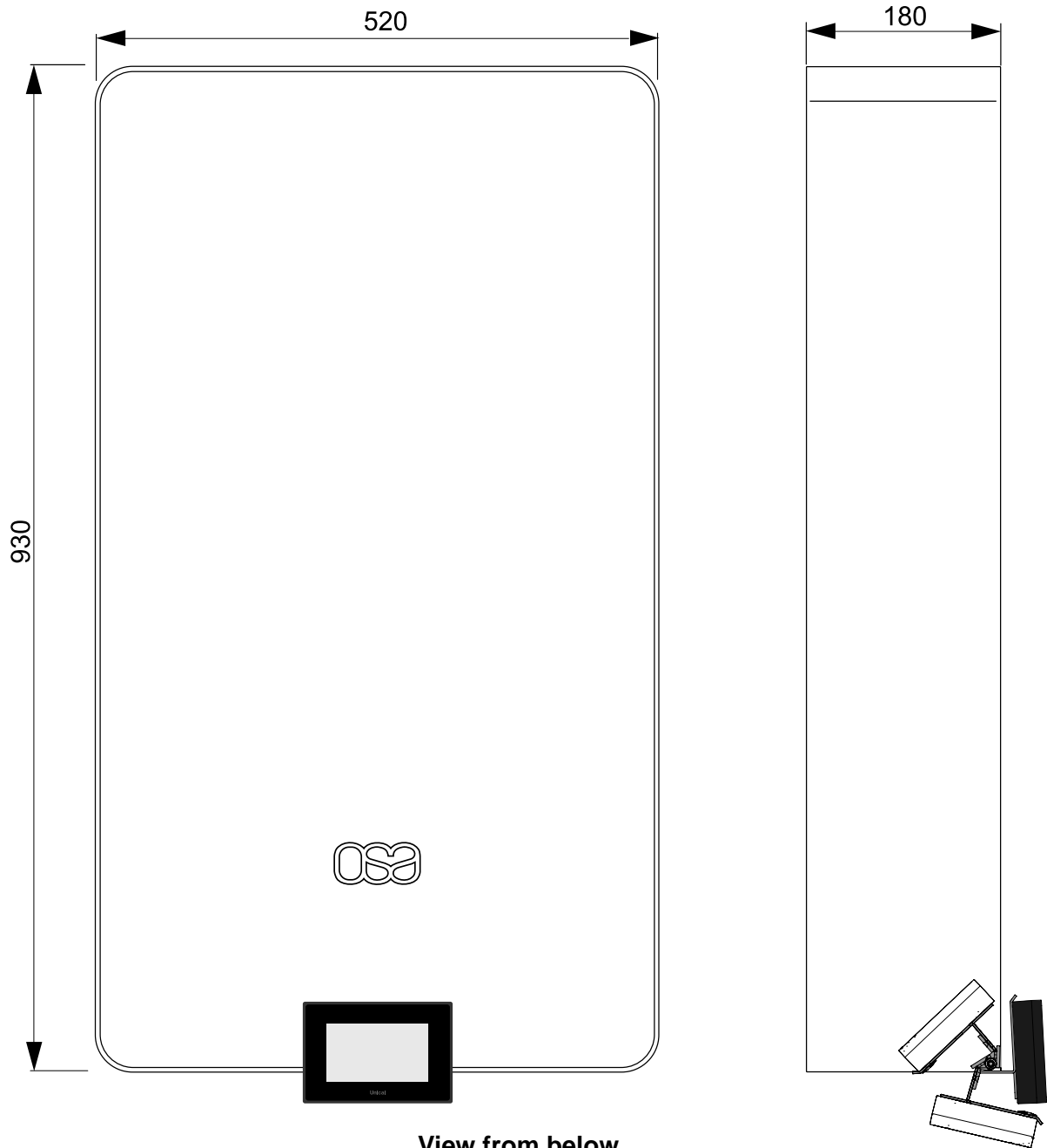

View from below

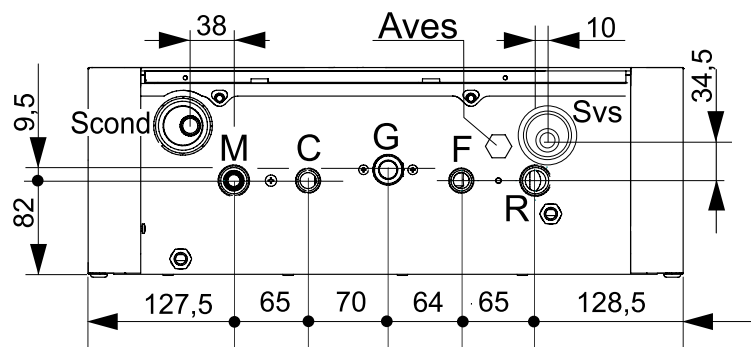

View from above

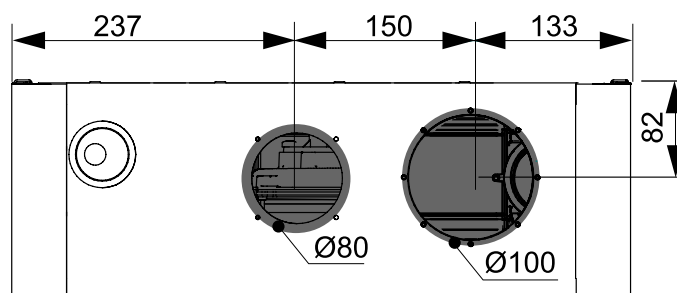

KEY			
N°	C.E.	S.E.	Description
1	db	SS	Domestic hot water temperature sensor
2		FLS	Flow switch with cold water filter
3		VG	Gas valve
4	Fd	E. ACC /RIL	Ignition/detection electrode
5			Burner
8			Expansion vessel
10	HL	TL	Safety thermostat
11	Hb	SR	Heating temperature sensor
12	Ht	P	Pump
13	Lp	DK	Water deficiency pressure switch
16			Diverter valve
17			Plate heat exchanger
18	FL FH	VM	Fan
20			Safety valve
22	rb	SRR	Return temperature sensor
23	tf	TLC	Flue gas collector safety thermostat
24			Aluminium Heat Exchanger/Capacitor
25			Vent valve

26			Condensation drain trap	
33			Ufly BOX (retractable)	
34			Gateway (external links)	
35			Emergency panel	
Aves			Connection for additional expansion vessel	
C			Domestic hot water outlet	G ½
G			Gas inlet	G ¾
F			Cold water inlet	G ½
M			Heating system flow	G ¾
R			Heating system return	G ¾
Rc			Filling valve	
Sc			Boiler drain	
Svs			Safety valve drain	
Scond			Condensation drain	
Ufp			Smoke rear output optional	
	C.E.		= ERROR CODES see par. 4.6	
		S.E.	= WIRING DIAGRAM KEY see par. 4.5	

2.3 - DIAGRAM OF FLOW RATE/PRESSURE AVAILABLE FOR INSTALLATION

MODULATING PUMP

DIAGRAM OF FLOW RATE/PRESSURE AVAILABLE FOR INSTALLATION

OSA S 24

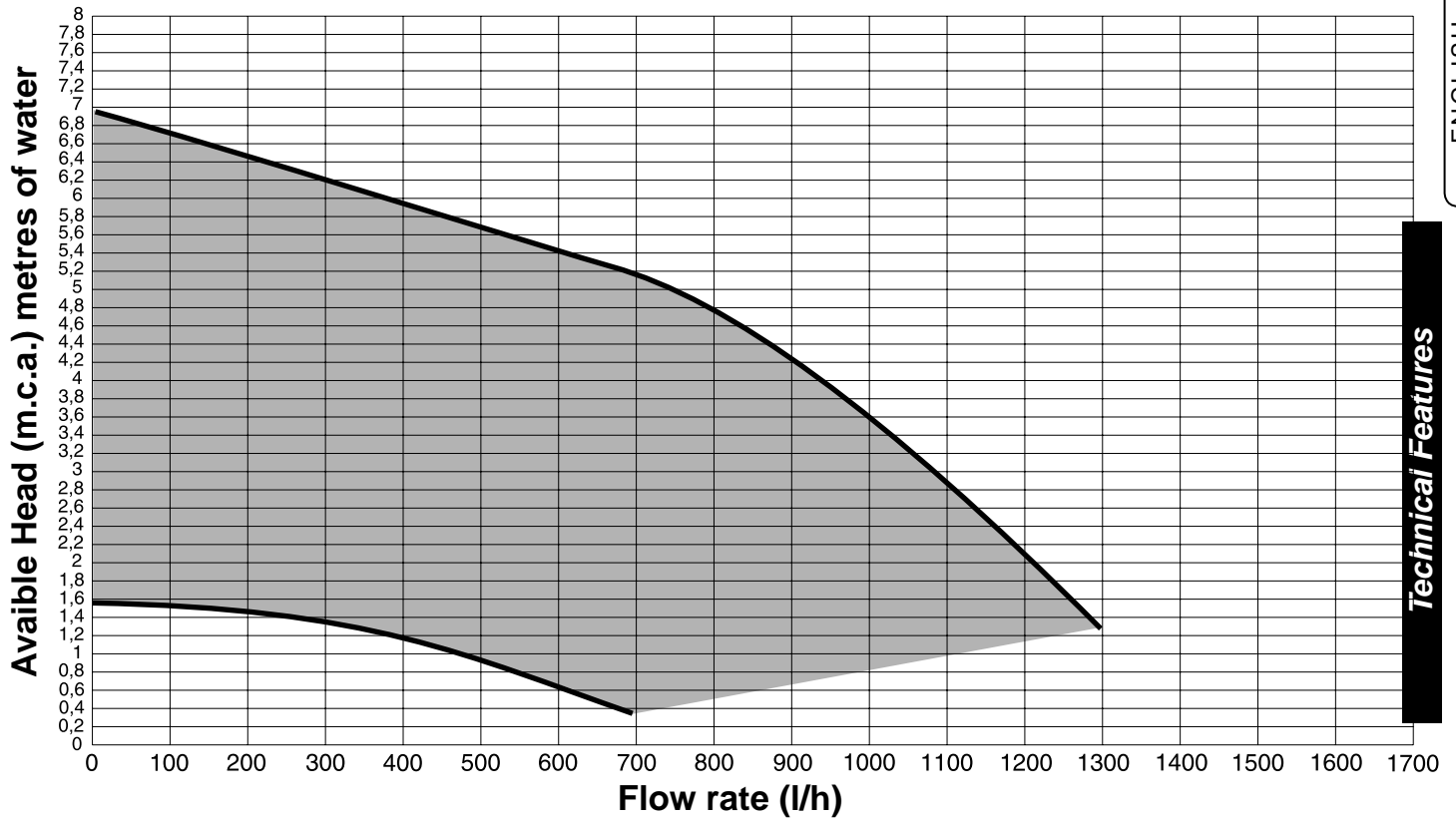

ENGLISH

Technical Features

OSA S 28 - OSA S 35

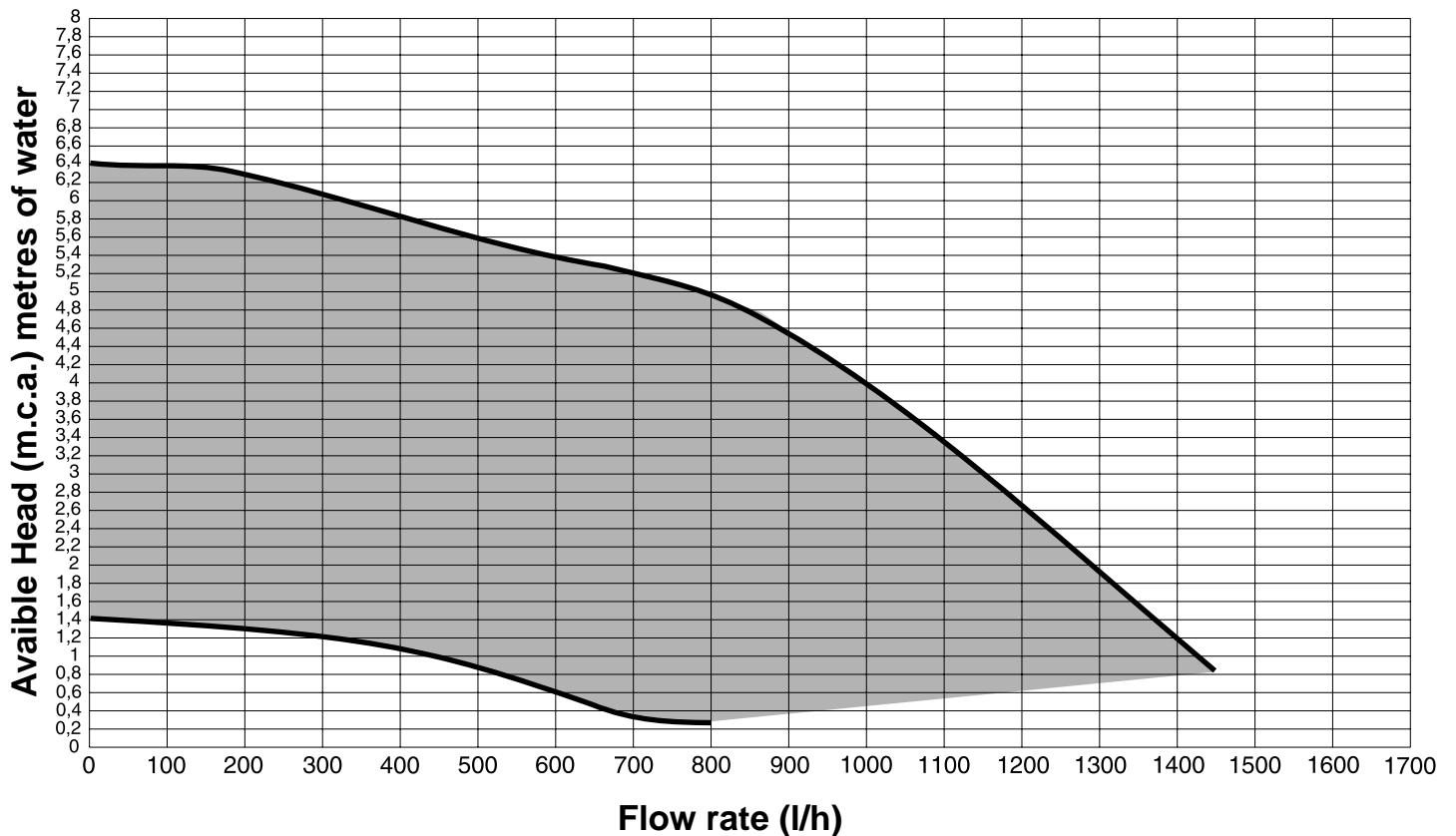

2.4 - OPERATING DATA ACCORDING TO UNI 10348

For the adjustment data: NOZZLES - PRESSURES - DIAPHRAGMS - FLOW RATES - CONSUMPTIONS refer to the paragraph ADAPTATION TO OTHER TYPES OF GAS.

		OSA S 24	OSA S 28	OSA S 35
Nominal heat input in CH / DHW mode	kW	23,4	28,0 / 33,0	33,0
Minimum heat input with Nat. Gas / Propane	kW	3,0 / 3,0	4,4 / 4,4	4,4 / 4,4
Nominal heat output	kW	23,02	27,3	32,2
Minimum heat output	kW	2,96	4,3	4,3
Nominal output in condensation 50/30 °C	kW	23,7	28,9	33,8
Minimum heat output in condensation 50/30 °C	kW	3,22	4,68	4,68
Combustion efficiency at full load	%	97,2	97,8	97,3
Combustion efficiency at part load	%	98,6	98,2	98,1
Heat losses through the casing (min.-max.)	%	1,4 - 1,0	1,1 - 0,2	1,1 - 0,2
(*) Net flue gas temperature $t_f - t_a$ (max.)	°C	56,8	45,1	54,8
Flue gas mass flow rate (min.-max)	g/s	1,35 - 10,5	2,0 - 12,5	2,0 - 14,7
Air excess λ	%	24,3	23,0	23,0
CO ₂	%	9,2 - 9,2	9,2 - 9,3	9,2 - 9,3
CO at 0% of O ₂ (min. - max)	ppm	22 - 114	14 - 88	14 - 94
Maximum production of condensate	kg/h	3,8	4,5	5,3
NOx class		5	5	5
Chimney heat losses with burner ON (min. - max.)	%	1,4 - 2,8	1,8 - 2,2	1,9 - 2,7
Chimney heat losses with burner OFF	%	0,35	0,34	0,34
Max. available pressure at the chimney base min. / max.	Pa	2 / 70	2 / 70	2 / 70

Notes: (*) Room Temperature = 20°C Data obtained with appliance operated with Nat Gas (G20)

2.4.1 - DATA ACCORDING TO ErP DIRECTIVE



Description	Symbol	Unit	OSA S 24	OSA S 28	OSA S 35
Nominal Heat Output	P _{nomiale}	kW	23	27	32
Seasonal space heating energy efficiency	η_s	%	94	94	94
Seasonal efficiency class in heating mode			A	A	A
Integrated Weather compensator and room sensor	Classe VI	%	4	4	4
Seasonal space heating energy efficiency of package	η_s Packaging	%	98	98	98
Seasonal space heating energy efficiency class of package			A+	A+	A+
For CH only and combination boilers: useful heat output					
Useful Heat Output in high-temperature regime (Tr 60 °C / Tm 80 °C)	P ₄	kW	13	16	18,4
Useful efficiency at nom. heat output in high-temperature regime (Tr 60 °C / Tm 80 °C)	η_4	%	88,7	88,9	88,7
Useful heat output at 30% of nom. heat output in low-temperature regime (Tr 30 °C)	P ₁	kW	4,3	5,3	6,1
Useful efficiency at 30% of nom. heat output in low-temperature regime (Tr 30 °C)	η_1	%	99,2	98,1	98,2
Range-rated boiler: YES / NO			YES	YES	YES
Auxiliary electricity consumption					
At full load	el _{max}	kW	0,085	0,093	0,093
At part load	el _{min}	kW	0,012	0,015	0,015
In stand-by mode	P _{SB}	kW	0,003	0,001	0,001
Other items					
Stand-by heat loss	P _{stb}	kW	0,0824	0,113	0,113
Emissions of nitrogen oxides	NOx	Mg/kWh	41	36	39
For CH & DHW production boilers					
Declared load profile			L	XL	XL
Energy efficiency in DHW production mode	η_{wh}	%	84	86	86
Daily electricity consumption	Q _{elec}	kWh	0,0644	0,0813	0,0813
Daily fuel consumption	Q _{fuel}	kWh	14,41	22,97	22,97
Inside sound power level	L _{wa}	dB (A)	53	54	54
Seasonal efficiency class in DHW production mode			A	A	A

2.4.2 - FEATURES OF INTEGRATED Ufly BOX

Ufly BOX control panel, together with room sensor temperature and outer sensor temperature provided as standard, performs the environmental thermoregulation work as described in the document 2014/C 207/02, section 6.1.

Class VI – Weather compensator and room sensor, for use with modulating heaters: A heater flow temperature control that varies the flow temperature of water leaving the heater dependant upon prevailing outside temperature and selected weather compensation curve. A room temperature sensor monitors room temperature and adjusts the compensation curve parallel displacement to improve room comfort. Control is achieved by modulating the output of the heater.

2.5 - GENERAL FEATURES

		OSA S 24	OSA S 28	OSA S 35
Appliance category		II _{ZH3P}	II _{ZH3P}	II _{ZH3P}
Minimum heat. circuit output (Δt 20 °C)	l/min	2,1	3,06	3,08
Minimum heating circuit pressure	bar	0,5	0,5	0,5
Maximum heating circuit pressure	bar	3	3	3
Primary circuit content	l	2,2	2,2	2,2
Maximum operating temperature in heat.	°C	85	85	85
Minimum operating temperature in heat.	°C	30	30	30
Expansion vessel total capacity	l	9 (6+3)	6	6
Expansion vessel pre-load	bar	1	1	1
Maximum system capacity (max temp. calc.)	l	185	123	123
Minimum domestic hot water circuit flow rate	l/min.	2	2	2
Minimum domestic hot water circuit pressure	bar	0,5	0,5	0,5
Maximum domestic hot water circuit pressure	bar	6	6	6
Domestic hot water specific flow rate (Δt 30 °C) "D"	l/min.	11,2	16	16
Domestic hot water flow rate limiter	l/min.	10	15	15
Production of D.H.W. in continuous operation with Δt 45 K	l/min.	7,3	10,3	10,3
Production of D.H.W. in continuous operation with Δt 40 K	l/min.	8,3	11,6	11,6
Production of D.H.W. in continuous operation with Δt 35 K	l/min.	9,4	13,3	13,3
Production of D.H.W. in continuous operation with Δt 30 K	l/min.	11,0	15,5	15,5
Production of D.H.W. in continuous operation with Δt 25 K (*)	l/min.	13,2	18,6	18,6
Voltage/Frequency electric power supply	°C	35-60	35-60	35-60
Fuse on the power supply	V-Hz	230/50	230/50	230/50
Maximum absorbed output	A (F)	3,15	3,15	3,15
Protection rating	IP	X4D	X4D	X4D
Net weight boiler	kg	41	41	41
Gross weight boiler	kg	45,7	45,7	45,7
Net weight front case (shell)	kg	3	3	3
Gross weight front case (shell)	kg	4,9	4,9	4,9
F factor		1	2	2
R factor				
(*) mixed				

3

INSTALLATION INSTRUCTIONS

3.1 - GENERAL WARNINGS



ATTENTION!

This boiler is intended solely for the use for which it was expressly designed. Any other use is to be considered improper and therefore dangerous.

This boiler heats water at a temperature lower than the atmospheric pressure boiling temperature.



Before connecting the boiler, have professionally qualified personnel:

a) **Thoroughly wash all the piping of the system to remove any residues or impurities which could jeopardise proper operation of the boiler, even from a hygienic point of view.**

b) Check that boiler is set up to operate with the available type of fuel. This can be seen written on the package and on the technical feature plate;

c) Check that the chimney/flue has an appropriate draught, without any bottlenecks, and that no exhausts from other appliances are inserted, unless the flue has been implemented to accommodate several utilities according to specific standards and regulations in force. Only after this check can the fitting between the boiler and chimney/flue be mounted;



ATTENTION!

If there is dust and/or if there are aggressive/corrosive vapours present in the installation room, the appliance must be protected suitably and must be able to operate independently from the air in the room.



ATTENTION!

Only mount the appliance on a closed wall, made of non-flammable material, flat, vertical so that the minimum distances required for installation and maintenance can be observed.



The boiler must be connected to a central heating system and/or domestic hot water supply network compatible with its efficiency and output.

NOTE!

**For more information
See Technical Info
from site indicated at pag. 2**

3.2 - INSTALLATION STANDARDS

It must be installed by a professionally qualified technician, **who shall take the responsibility of observing all local and/or national laws published in the official journal, as well as the applicable technical standards.**

NOTE!

For further details relating to the standards, rules and regulations for safe installation of the thermal unit, refer to the section "Technical Information" on the boiler page of the www.unicalag.it website

3.3 - PREVENTIVE VERIFICATION AND VERIFICATION AND ADJUSTMENT OPERATIONS

NOTE!

**For more information
See Technical Info
from site indicated at pag. 2**

3.4 - PACKAGING

The OSA boiler is supplied completely assembled in a sturdy cardboard box.



After having removed the appliance from the packaging, make sure that the supply is complete and undamaged.



The packaging elements (cardboard box, straps, plastic bags, etc.) **must be kept out of the reach of children as they are potential sources of danger.** Unical AG S.p.A. will not be held liable

for damage to persons, animals or objects due to failure to comply with the instruction above.

As well as the appliance, the packaging contains:

- A DOCUMENTATION ENVELOPE
 - User operating instructions booklet
 - Instruction booklet for the installer and maintenance engineer
 - Warranty
 - 2 Spare parts form
 - Certificate of conformity
 - Gas conversion label
- B - Connection predisposition paper template
- D - Chimney spacer
- E - Bracket for fixing
- F - Ufly BOX
- G - Outer sensor + Remote temperature sensor

ENGLISH

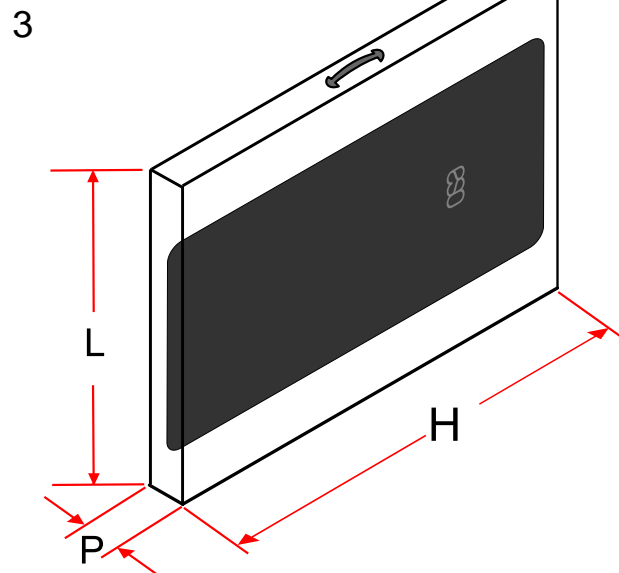
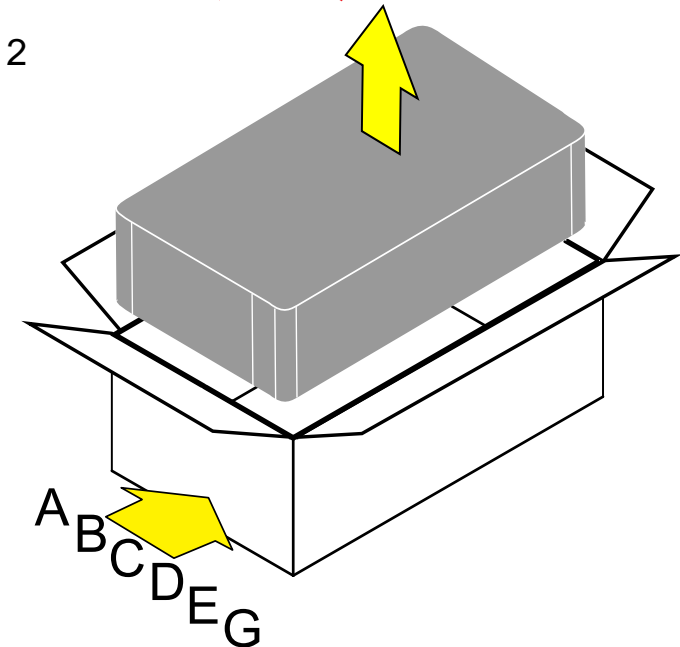
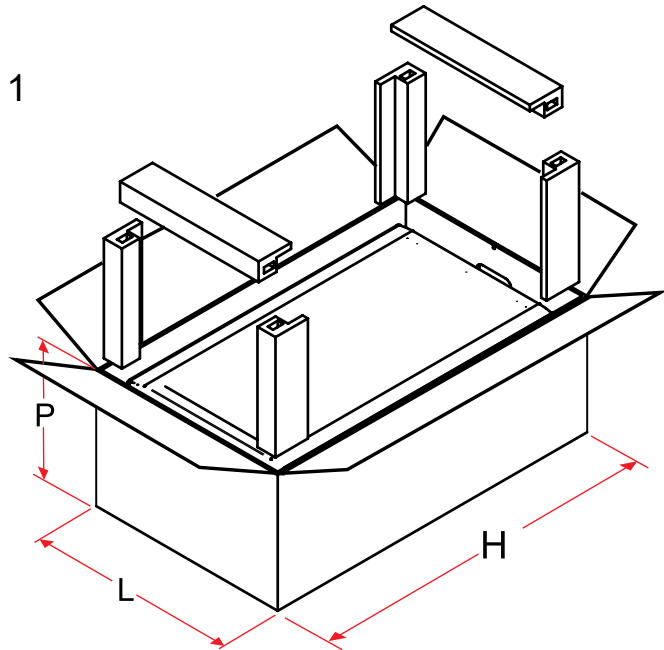

Installation Instructions

BOILER			
OSA S	P Depth	L Width	H Height
	200 mm	540 mm	1010 mm

SHELL			
OSA S	P Depth	L Width	H Height
	62 mm	592 mm	1000 mm

3.5 - POSITIONING THE BOILER

When choosing the place of the installation of the appliance, follow the safety instructions below:

- Place the appliance in rooms protected from frost.
- Avoid installation in rooms with a corrosive or very dusty atmosphere.
- The appliance must only be installed on a vertical and solid wall which can support its weight.
- The wall must not be made of flammable material.

Since the temperature of the wall on which the boiler is installed and the temperature of the coaxial exhaust pipe do not exceed, in normal operating conditions, a room temperature beyond 60 K, it is not necessary to observe the minimum distances from flammable walls.

For boilers with double intake and exhaust pipes, in the event of crossing flammable walls, insert insulation between the wall and the flue gas exhaust pipe.

OSA S 24 - OSA S 28 - OSA S 35

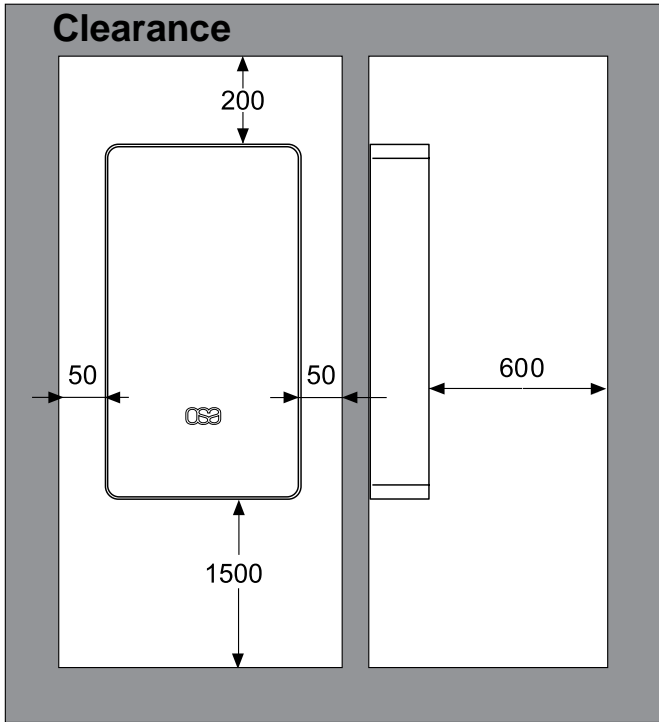
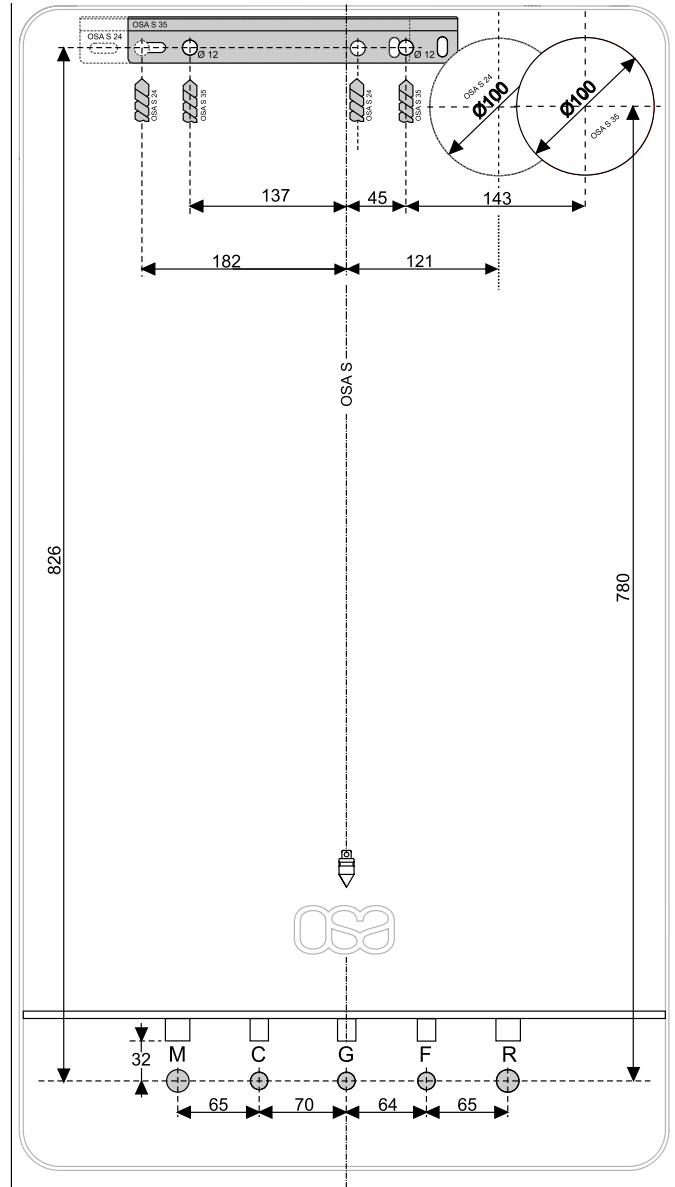

3.6 - FLUE GAS EXHAUST PIPE CONNECTION FOR BOILERS WITH FORCED DRAUGHT

To connect the flue gas exhaust pipe, local and national standards must be observed

In the event the boiler is replaced, ALWAYS re-

place the flue gas pipe as well.

The boiler is type approved for the exhaust configurations listed below:

C13x		C13	
% Slope towards inlet = 3%			
TOTAL LENGTH (LA intake + L Exhaust)			
COAXIAL Ø60/100		DOUBLE Ø80	
FROM [m]	TO [m]	FROM [m]	TO [m]
1	5,5	1 + 1	40 (20A+20S)
COAXIAL Ø80/125		DOUBLE Ø60	
FROM [m]	TO [m]	FROM [m]	TO [m]
1	8	1 + 1	20 (10A+10S)
		Distance between air inlet pipe and flue gas exhaust pipe: min 250 mm - max 500	
Horizontal exhaust and intake terminals directed outside via coaxial or double pipes..			

C33x		C33	
TOTAL LENGTH (LA intake + L Exhaust)			
COAXIAL Ø60/100		DOUBLE Ø80	
FROM [m]	TO [m]	FROM [m]	TO [m]
1	7	0,5 + 0,5	40 (20A+20S)
COAXIAL Ø80/125		DOUBLE Ø60	
FROM [m]	TO [m]	FROM [m]	TO [m]
1	9	1 + 1	20 (10A+10S)
Vertical exhaust and intake terminals directed outside via coaxial or double pipes.			

C43x	C43
Collective chimney flue system, consisting of two pipes, one for combustion air intake and the other one for combustion products evacuation, coaxial or double.	

C53x	C53

C53 NOT ALLOWED	C53
TOTAL LENGTH (LA intake + L Exhaust)	
DOUBLE Ø80	
FROM [m]	TO [m]
1 + 1	40 (max 30 S)
DOUBLE Ø60	
FROM [m]	TOA [m]
1 + 1	20 (max 15 S)
Separate combustion air intake and combustion products evacuation pipes. These pipes can discharge into areas with different pressure.	

ENGLISH

Installation Instructions

C63x	C63
Boiler intended for connection to a combustion air intake and combustion products evacuation system, approved and sold separately	

	ATTENTION: The flue must comply with standards in force.
--	--

C83x	C83
Connection to a terminal for combustion air intake and flue gas exhaust via a single or collective chimney.	

C93x	C93
Air / flue gas through concentric pipes in the boiler room and single pipes in the chimney (combustion air with counterflow in the chimney)	

B23P

TOTAL LENGTH (LS)	
DOUBLE Ø80	
FROM [m]	TO [m]
1	30

Connection to a combustion products evacuation pipe outside the room; the combustion air is taken directly from the room where the appliance is installed.

	ATTENTION: For the type of connection B23P the room follows the same installation rules for boilers with natural draught.
--	--

	CAUTION LT total length is a reference value for the dimensioning of the ducts of A (intake) and S (Exhaust). Subtracting the values of LT reported, at values of bends* / terminals* / extensions* you get the value: if > 0 = OK - POSSIBLE configuration if < 0 = NO - WRONG configuration
--	---

(*) Values in the **MT018** available on the website.

	Please note: These values relate to exhausts/ made by means of rigid pipes and smooth original UNICAL.
--	--

NOTE!
For more information
See Technical Info
from site indicated at pag. 2

GENERAL INFORMATION ON THE FLUE GAS EXHAUST SYSTEM

Rear smoke outlet not possible

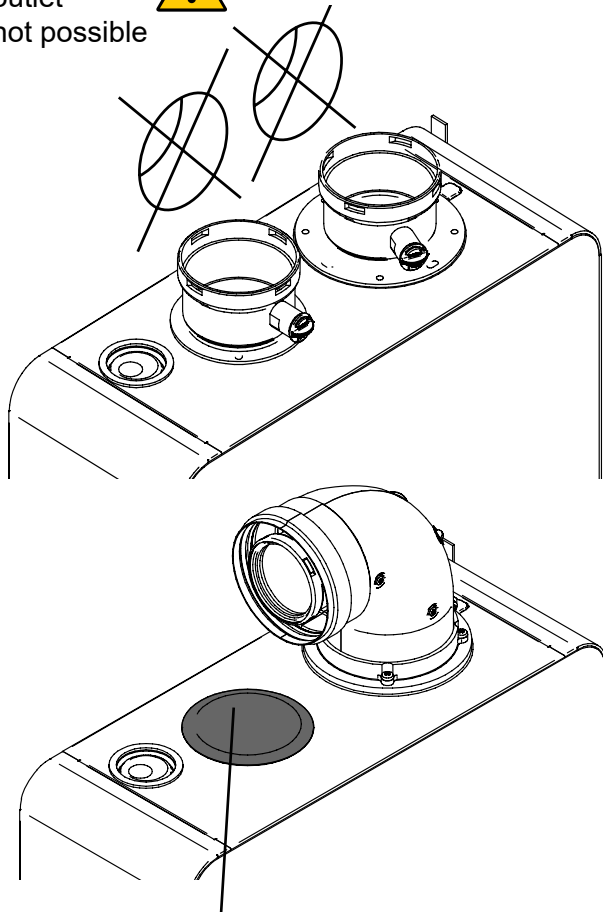

Rubber sealing caps

(Remove according to the type Exhaust used:

HIGHER

- Split (remove both)
- Coaxial (leave only one shown)

REAR NOT VISIBLE

(rear in the boiler)

installation instructions in the kit.

it is possible only with coax (Leave 2 above).

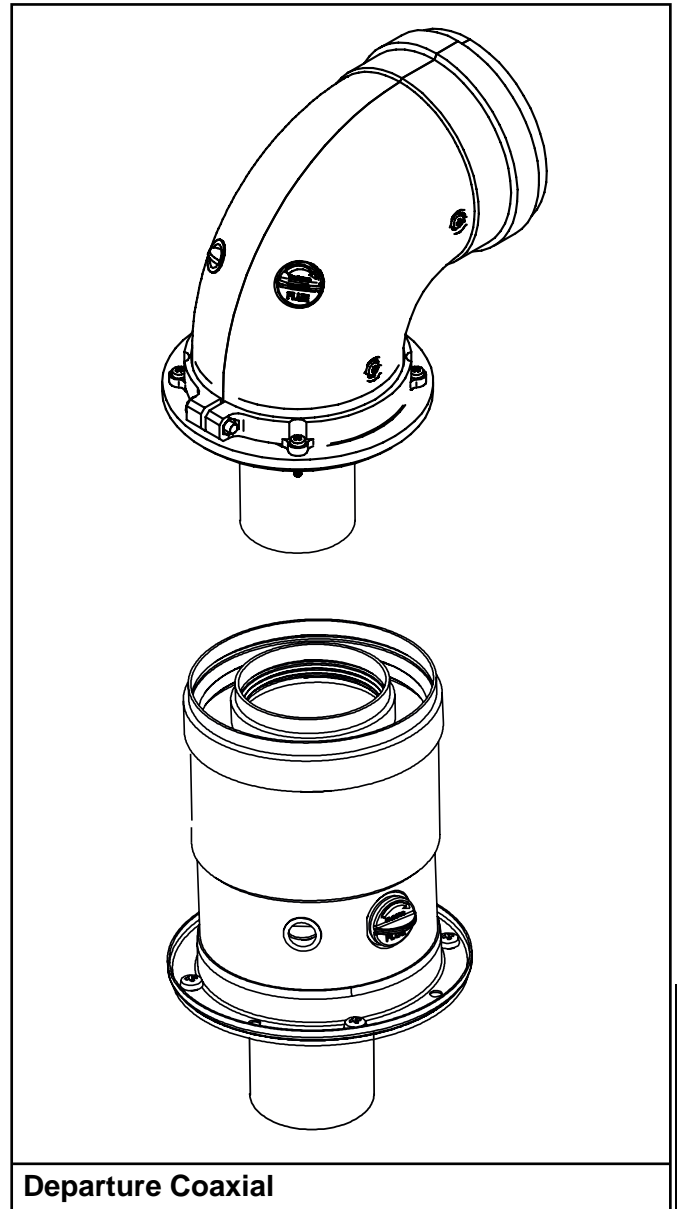

Departure Coaxial



It is recommended to only use original Unical exhaust pipes.

The supplier will have no contractual or extra-contractual liability for damage caused due to incorrect installation and use and in any case failure to comply with the instructions provided by the manufacturer.

NOTE!

For further details relating to pressure drops of the individual components, for information on standards, rules and regulations for proper flue gas exhaust, refer to the "Technical Information" section on the boiler page of the www.unicalag.it website

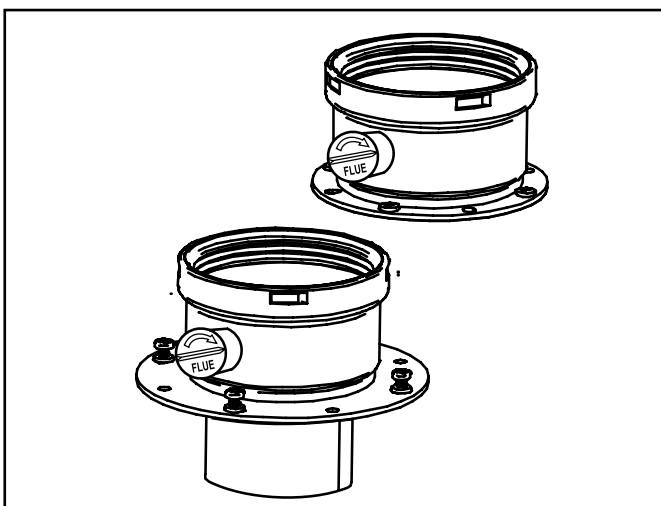

(+) Adapter for double systems

3.7 - CONNECTION

G	GAS	3/4"
---	-----	------



Danger!

The gas connection must be carried out only by a qualified installer who must respect and apply that foreseen by relevant laws in force in the local prescriptions of the supply company. Incorrect installation can cause damage to persons, animals and objects for which the manufacturer cannot be held responsible.



If you smell gas:

- Do not operate electric switches, the telephone or any other object that may cause sparks;
- Immediately open doors and windows to create air current to purify the room;
- Shut the gas cocks.

M	FLOW	3/4"
R	RETURN	3/4"
C	HOT	1/2"
F	COLD	1/2"

Sc	BOILER DRAIN
S.cond	CONDENSATION DRAIN
Rc	FILLING VALVE
Svs	SAFETY VALVE DRAIN Provide a drain pipe with funnel and a trap that lead to a suitable drain, in correspondence of Svs. This drainage must be controlled on sight. If this precaution is not taken, triggering of the safety valve can cause damage to persons, animals and objects, for which the manufacturer cannot be held responsible.
Aves	Connection for additional expansion vessel.

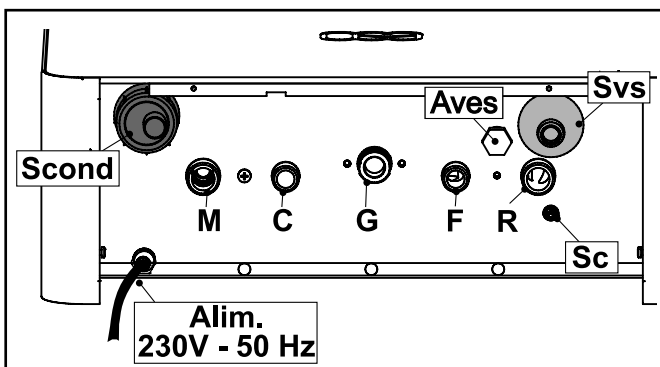

The mains pressure must be within 1 and 3 bar (in the event of greater pressure install a pressure reducer).

Condensation drain

The boiler, during the combustion process, produces condensation that, through pipe "A", flows into the trap.

The condensation that forms inside the boiler flows into a suitable drain via pipe "B".



Danger!

Before commissioning the appliance:

- check that the trap is assembled properly
 - fill the trap and check that the condensation is drained properly
- If the appliance is used with an empty condensation drain trap, there is an intoxication hazard due to the release of exhaust gasses.

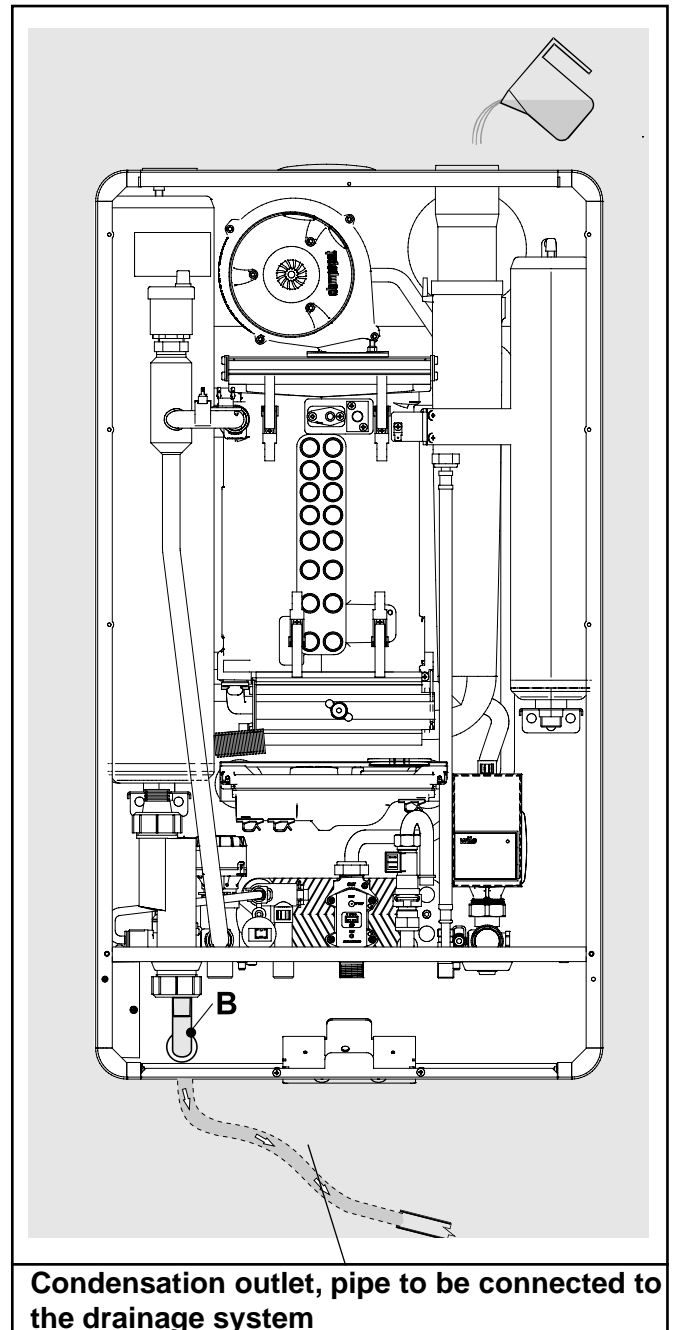

Condensation outlet, pipe to be connected to the drainage system



The connection between the appliance and the domestic waste system must be made in compliance with the specific reference standards.

NOTE!
For more information
See Technical Info
from site indicated at pag. 2

3.8 - FILLING THE SYSTEM



Attention!
Do not mix the heating water with incorrect concentrations of antifreeze or anti-corrosion substances! This could damage the gaskets and cause noise during operation.

When the system connections have been completed, the circuit can be filled.

This operation must be performed carefully, respecting the following phases:

- open the radiator vent valves and make sure the automatic valve is working properly in the boiler.
- ONLY FOR FIRST FILL - normally the filling is automatic - open the filling tap gradually **Rc** (mediante cacciavite) making sure that the automatic air release valves installed on the system work properly.
- close the radiator air release valves as soon as water comes out.
- check the pressure gauge U-fly until pressure reaches approximately 0.8/1 bar.
- close the filling tap **Rc** and bleed air once again through the radiator air release valves.
- make sure that all the connections are watertight.
- after commissioning the boiler (see par. 3.10) and bringing the system to the operating temperature, stop the boiler and repeat the air bleed operations.
- let the system cool down and, if necessary, return the water pressure to 0.8/1 bar.
(See par. 4.5).



Unical will not be held liable for damage to persons, animals or objects due to failure to comply with the above instruction.



Note: The first fill of the boiler must be made manually.

FILLING VALVE
Screw in load position
LOAD

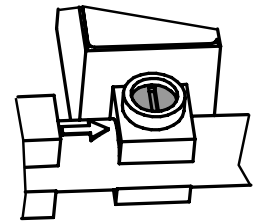

FILLING VALVE
Screw in position of
NORMAL OPERATION.

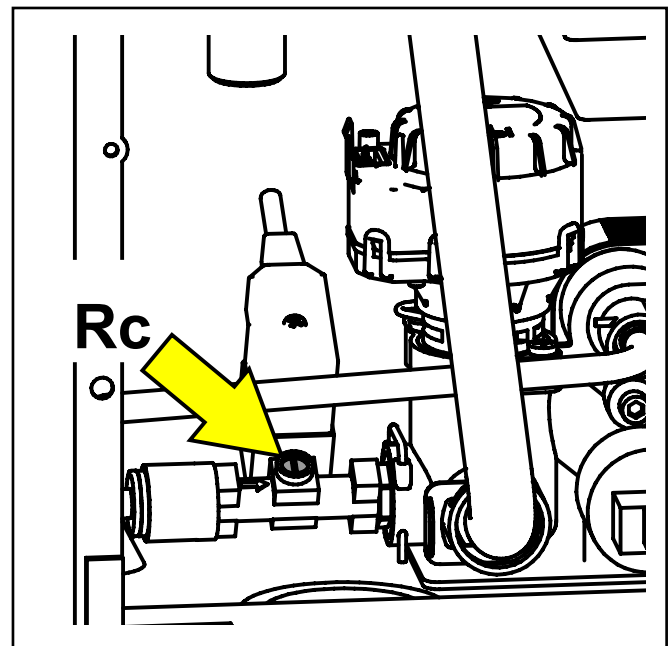
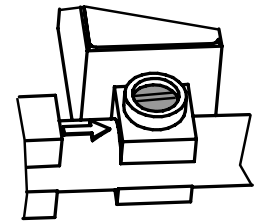

The filling valve **Rc** is positioned behind the siphon.

3.9 - ELECTRICAL CONNECTIONS



Danger!
 Only a qualified technician may perform the electrical installation.
 Before performing connections or

any type of operation on electrical parts, always disconnect electrical power and make sure that it cannot be reconnected accidentally.

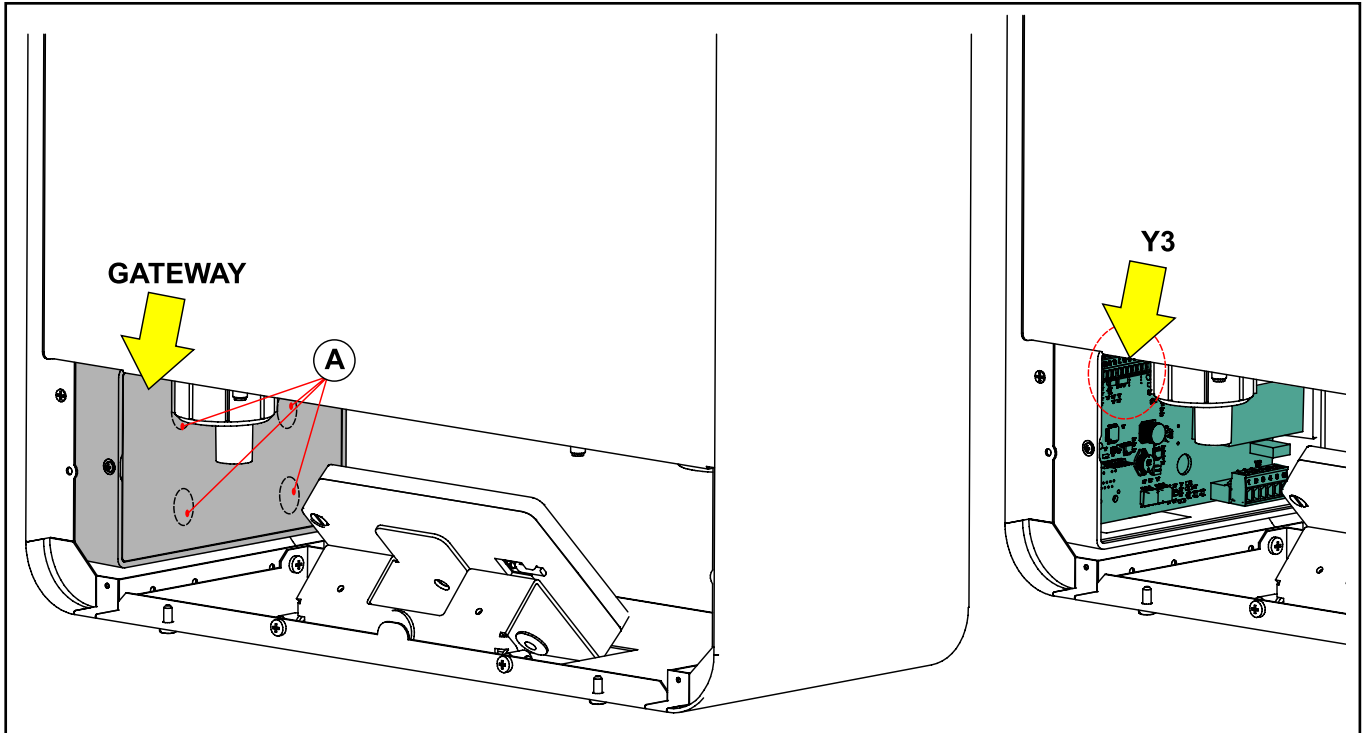

The external connections have to be made on the GATEWAY (connector Y3), the cable exits will be made in grooves on cover A.

(*) Optional

OT/TA = ON-OFF room thermostat (*)
OT (OpenTherm) is not enabled

- Arranged on GATEWAY connector, Y3 5-6. Remove the jumper and connect the wires of the room thermostat between terminals.

SA = Room sensor supplied

- Arranged on GATEWAY connector, Y3 9-10, Remove the bridge between terminals 5-6.

SE = Outside sensor supplied

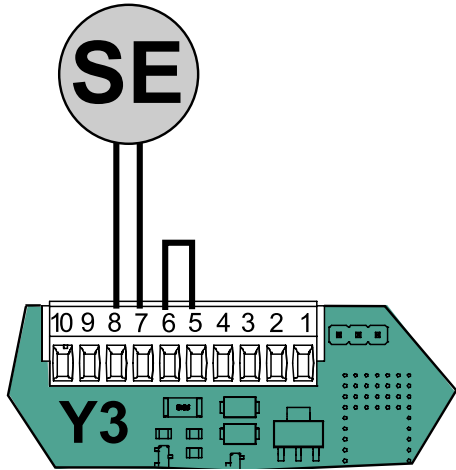

- Arranged on GATEWAY connector, Y3 7-8.

SHC = Multifunction module (*)

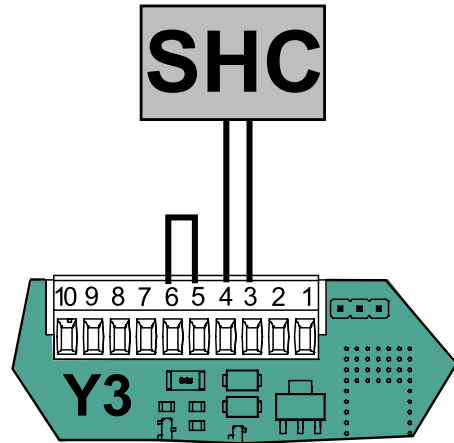

- Arranged on GATEWAY connector, Y3 4-3.

Electric power supply connection

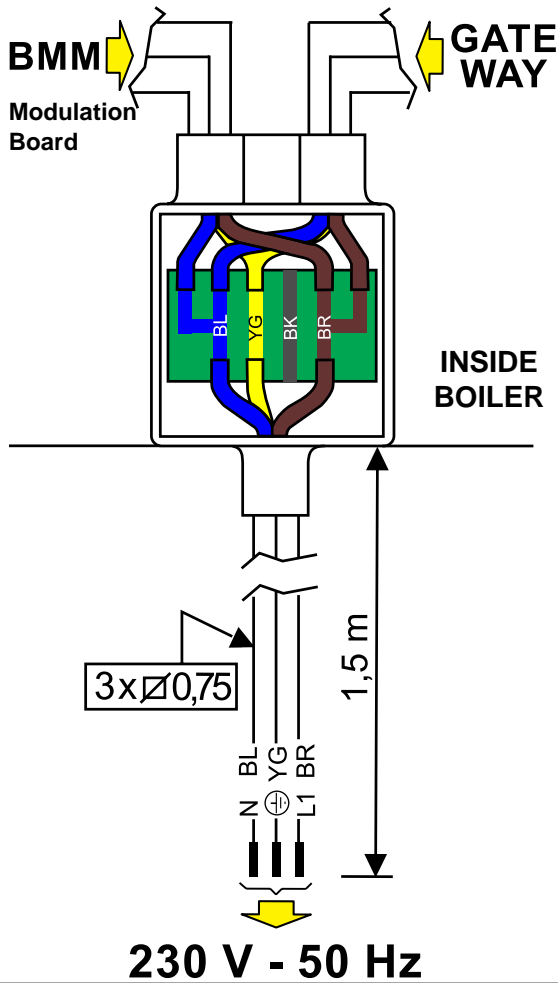

The boiler is equipped with a power cable, boiler installation requires electrical connection to the mains power supply. This connection must be made up to standard, as required the regulations in force.



Remember that a bipolar switch must be installed on the boiler power line with over 3 mm between contacts, easy to access, making maintenance quick and safe.



The power cable must be replaced by technical personnel authorised by UNICALAG S.p.A., using original spare parts only. Failure to comply with the above can jeopardise the safety of the appliance.



If necessary the shield of the sensor cable, can be connected to the terminal. (Ground connections - modulation board).

See par. 4.5 positioning on the board

(*) Optional

Installation Instructions

3.10 - COMMISSIONING



Commissioning must be done by professionally qualified personnel. Unical AG S.p.A. will not be held liable for damage to persons, animals or objects due to

failure to comply with the above instruction. Before commissioning the boiler, check that:

does the installation meet the specific standards and regulations in force, both relating to the gas part as well as the electrical part?	<input type="checkbox"/>
do the combustion air intake and flue gas exhaust take place properly according to what is defined by the specific rules and regulations in force?	<input type="checkbox"/>
is the fuel supply system sized according to the capacity required by the boiler? Is it equipped with all safety and control devices required by the standards in force?	<input type="checkbox"/>
is the power supply of the boiler 230V - 50Hz?	<input type="checkbox"/>
has the system been filled with water (approximately 0.8/1 bar pressure on the pressure gauge with the pump stopped)?	<input type="checkbox"/>
Has the condensation drain trap been filled with water as indicated in chapter 3.7?	<input type="checkbox"/>
are any system shut-off gate valves open?	<input type="checkbox"/>
does the gas to be used correspond to the boiler calibration gas?: otherwise, perform the boiler conversion in order to use the gas available (see section: 4.3"); this operation must be carried out by technical staff qualified in compliance with the standards in force;	<input type="checkbox"/>
is the gas supply valve open?	<input type="checkbox"/>
has the system been checked for gas leaks?	<input type="checkbox"/>
is the outside main switch ON?	<input type="checkbox"/>
is the system safety valve efficient and is it connected to the drains? is the condensation drain trap connected to the drains?	<input type="checkbox"/>
has the system been checked for water leaks?	<input type="checkbox"/>
are the ventilation conditions and minimum distances to perform any maintenance ensured?	<input type="checkbox"/>
have the GAS, HEATING and DOMESTIC HOT WATER pipes been cleaned thoroughly with products suitable for each circuit?	<input type="checkbox"/>
has a surveillance and protection system against gas leaks been installed? (Optional)	<input type="checkbox"/>
are the system pipes NOT used as the electrical system earthing?	<input type="checkbox"/>
has the system been sized properly bearing in mind the radiator pressure drops? thermostatic valves, radiator stop valves	<input type="checkbox"/>
has the operator been trained and has the documentation been supplied?	<input type="checkbox"/>
Please tick the operations performed	

Switching boiler on and off

NOTE!

For more information
See Technical Info
from site indicated at pag. 2

3.11 - MEASUREMENT OF COMBUSTION EFFICIENCY DURING INSTALLATION

3.11.1- ACTIVATION OF THE CALIBRATION FUNCTION

ATTENTION!
 Function reserved for Authorised Assistance Centres only.

ENGLISH

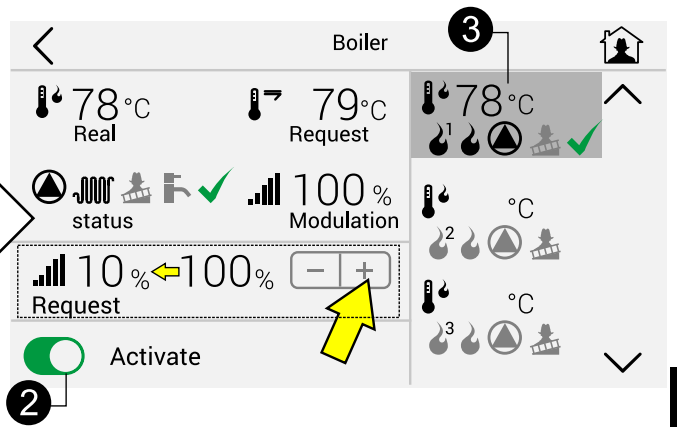
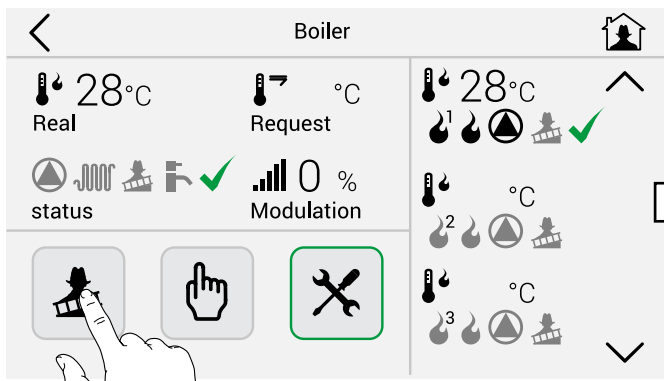
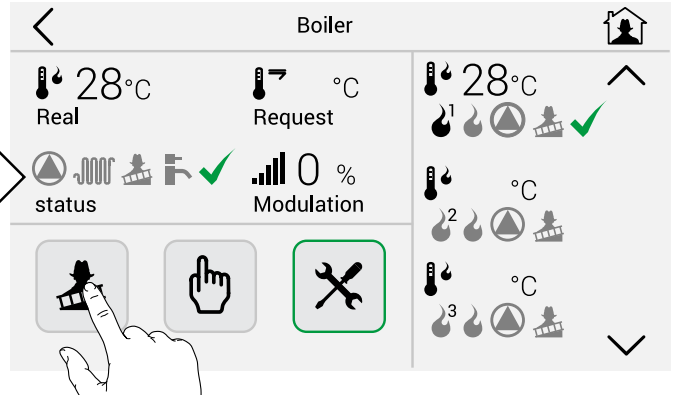
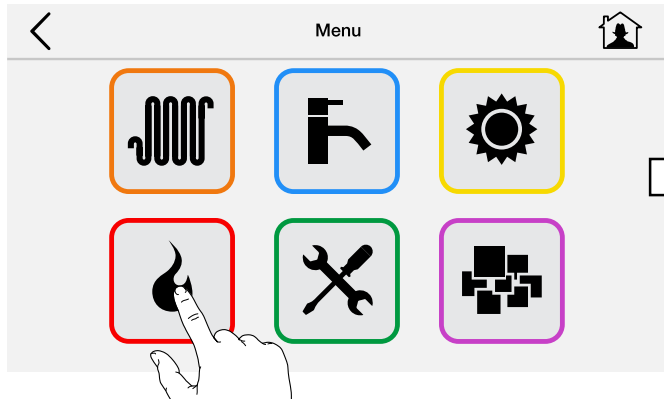

1 - Insert psw and select sweeper again

- Vary % mod. request from 10 % to 100 %
- 2 - Activation
- 3 - Chose burner among those available, eg: usually 1 / modulex (from 1 to 8).

Note: once selected the burner, (3) the display page changes: Burner # 1 # 8

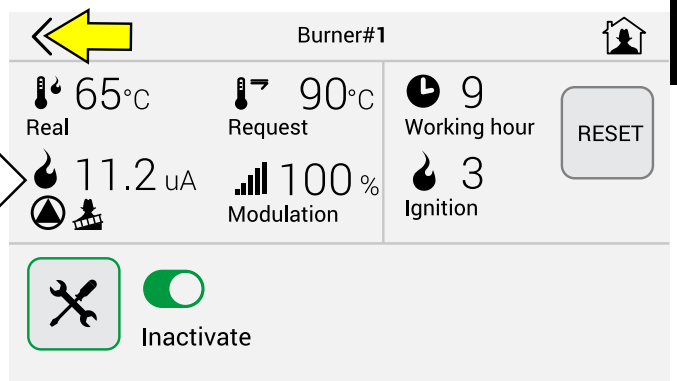
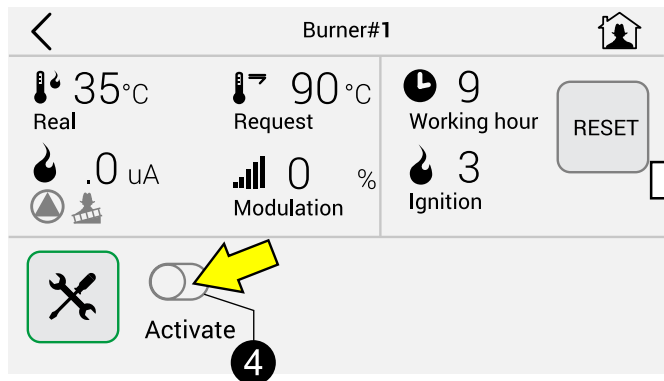

4 - Activation

Note: the selected burner is running at maximum power (modulation 100%)
 Pressing button < go back one page, burner menu'.

Installation Instructions

Boiler control panel showing 100% modulation and 5 burners operating to maximum power.

Boiler control panel showing 0% modulation and 6 burners selected.

Burner#1 control panel showing 0% modulation and burner inactivated.

Burner#1 control panel showing burner activated.

5 - Burner operating to maximum power (modulation 100%).

6 - Vary % of modulation request to the minimum 10% and select the burner

7 - Boiler operating with modulation min. (modulation 0%).

8 - Disable SWEEPER function. Exit by pressing Home icon.

3.11.2 - POSITIONING THE PROBES

To determine the combustion efficiency one must make the following measurements:

- measurement of the combustion air temperature taken in the relevant hole 2.

- measurement of the flue gas temperature and content of CO₂ taken in the relevant hole 1.

Take the measurements with the generator in steady state conditions (see par. 3.11.1).

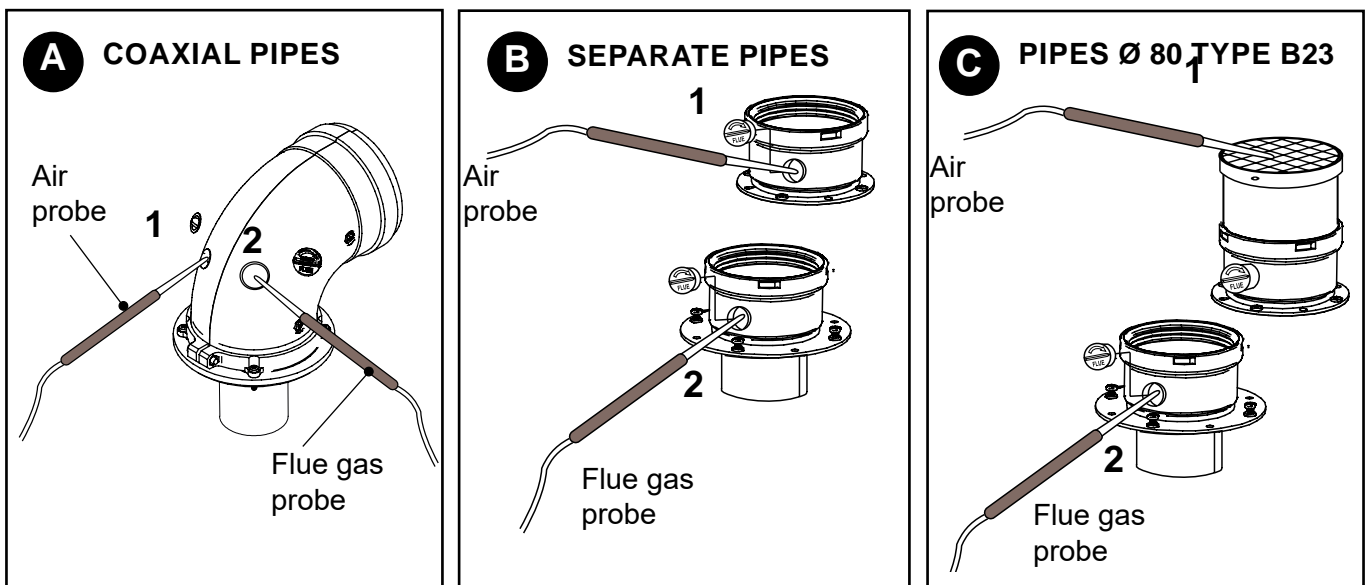

NOTE:
Do not enter immediately the analyzer probe in the sampling point, to avoid the saturation analyzer.



It's important to perform also the combustion air of combustion analysis, (Observing that the concentration of oxygen falls O₂ = 20.8% tolerance 0.2 - 0.4%). This is to prevent there being any recirculation of the fumes.

3.12 - ADJUSTING THE BURNER



Check the levels of CO₂ often, especially with low flow rates. They refer to the boiler with a closed combustion chamber.

PRESSURE - FLOW RATES TABLE

OSA S 24											
Type of Gas	Effective Output [kW]	Heating Thermal [kW] Capacity	Supply Press. [mbar]	Fan speed [rpm]		Collector diaphragm [Ø/n. holes]	CO ₂ levels [%]		Con- sumption	Con- sumption	Start-up power IG [%]
				min	max		min	max	min	max	
Nat. gas (G20)	2,96 - 23,0	3 - 23,4	20	-	-	-	9,2 (*)	9,2 (*)	0,32 m ³ /h	2,48 m ³ /h	-
Propane (G31)	2,96 - 23,0	3 - 23,4	37	-	-	-	10,5(+)	10,5(+)	0,23 kg/h	1,82 kg/h	-
(*) 9,0 ± 9,8 Acceptable range for G20						(+) 10,0 ± 11,0 Acceptable range for G31					

OSA S 28											
Type of Gas	Effective Output [kW]	Heating Thermal [kW] Capacity	Supply Press. [mbar]	Fan speed [rpm]		Collector diaphragm [Ø/n. holes]	CO ₂ levels [%]		Con- sumption	Con- sumption	Start-up power IG [%]
				min	max		min	max	min	max	
Gas nat. (G20)	4,3 - 27,3	4,4 - 28,0	20	-	-	-	9,2 (*)	9,3 (*)	0,47 m ³ /h	2,96 m ³ /h	-
Propano (G31)	4,3 - 27,3	4,4 - 28,0	37	-	-	-	10,4(+)	10,5(+)	0,34 kg/h	2,17 kg/h	-
(*) 9,0 ± 9,8 Acceptable range for G20						(+) 10,0 ± 11,0 Acceptable range for G31					

OSA S 35											
Type of Gas	Effective Output [kW]	Heating Thermal [kW] Capacity	Supply Press. [mbar]	Fan speed [rpm]		Collector diaphragm [Ø/n. holes]	CO ₂ levels [%]		Con- sumption	Con- sumption	Start-up power IG [%]
				min	max		min	max	min	max	
Gas nat. (G20)	4,3 - 32,2	4,4 - 33,0	20	-	-	-	9,2 (*)	9,3 (*)	0,47 m ³ /h	3,49 m ³ /h	-
Propano (G31)	4,3 - 32,2	4,4 - 33,0	37	-	-	-	10,4(+)	10,5(+)	0,34 kg/h	2,56 kg/h	-
(*) 9,0 ± 9,8 Acceptable range for G20						(+) 10,0 ± 11,0 Acceptable range for G31					

If the CO₂ level detected is out of recommended range, verify the integrity of the electrode.
In case of necessity replace the electrode.
If the problem persists you can use the functions described below.

3.12.1 - COMBUSTION ADJUSTMENT FUNCTION ACTIVATION

This function allows a partial adjustment of the CO₂ value on the following modulation points:

Maximum output	100	%
Start-up output	xx	%
Minimum output	0	%

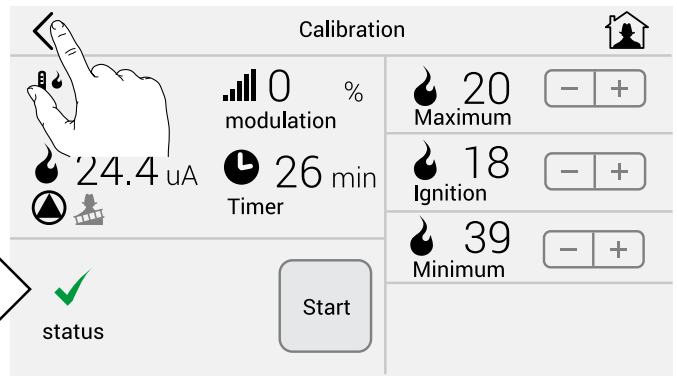

After Auto Calibration GAC par. 4.3.1
Perform combustion adjustment calibration as indicated:

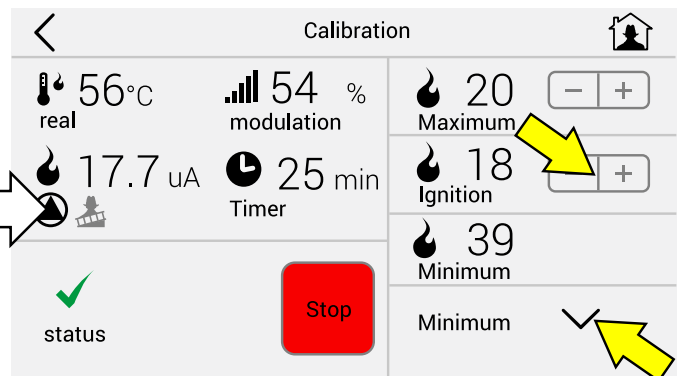
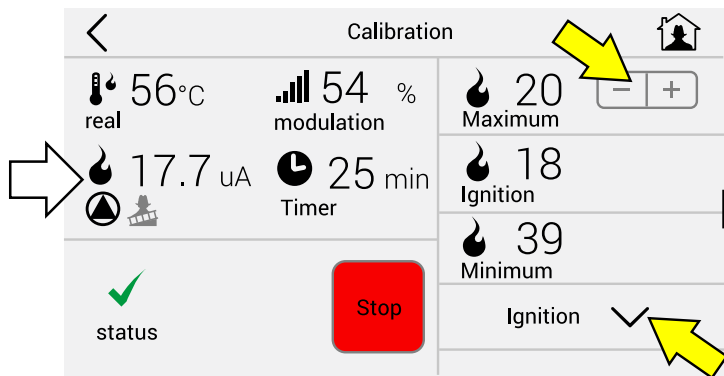
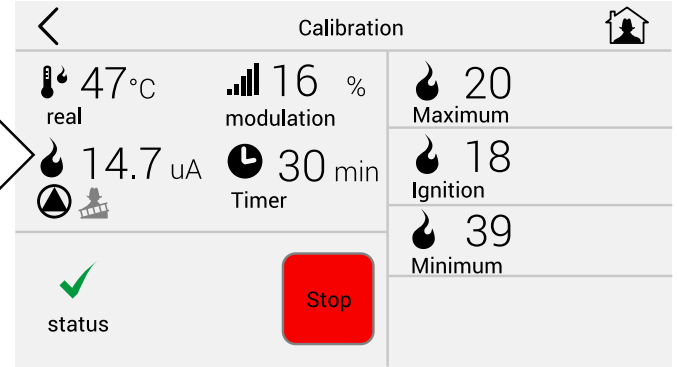
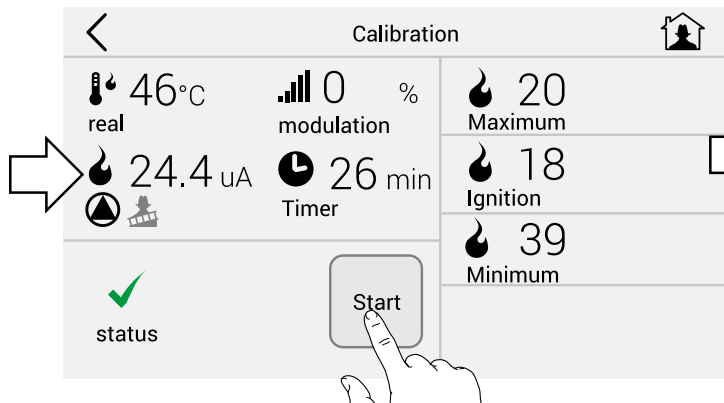

If the CO₂ value is not as expected, when appears **box (+/-)**, you can retouch the value of the Maximum Power.
If the desired value has been reached, proceed to the next level by pressing: Ignition

If the CO₂ value is not as expected, when appears **box (+/-)**, you can retouch the value of the Ignition. If the desired value has been reached, proceed to the next level by pressing: Minimum

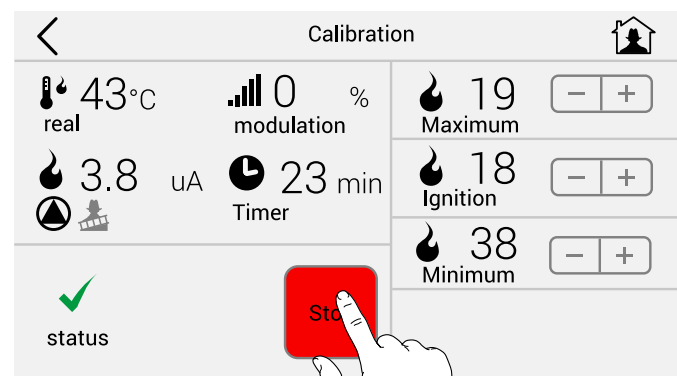
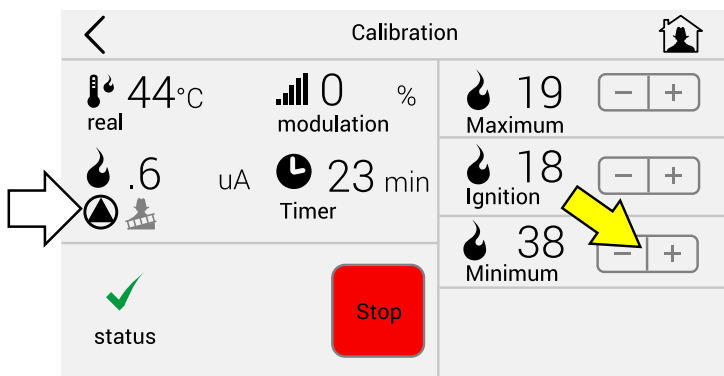

If the CO₂ value is not as expected, when appears **box (+/-)**, you can retouch the value of the Minimum Power.

The combustion adjustment is finished.

3.12.3 - ADAPTATION OF THE POWER TO THE HEATING SYSTEM



ATTENTION!
Function reserved for Authorised Assistance Centres only.

The user is **NOT** authorised to activate the function described below.

It is possible to adjust the maximum thermal capacity in heating mode, by decreasing the burner pressure value.

Act on parameter **792** (par. 4.2 SE parameters list) to achieve the value corresponding to the desired output.

E.g.: **OSA S 24**
to decrease the output of the boiler to 18 kW, edit parameter 792 on Ufly BOX (about 70).

E.g.: **OSA S 28**
to decrease the output of the boiler to 20 kW, edit parameter 792 on Ufly BOX (about 65).

E.g.: **OSA S 35**
to decrease the output of the boiler to 24 kW, edit parameter 792 on Ufly BOX (about 68).

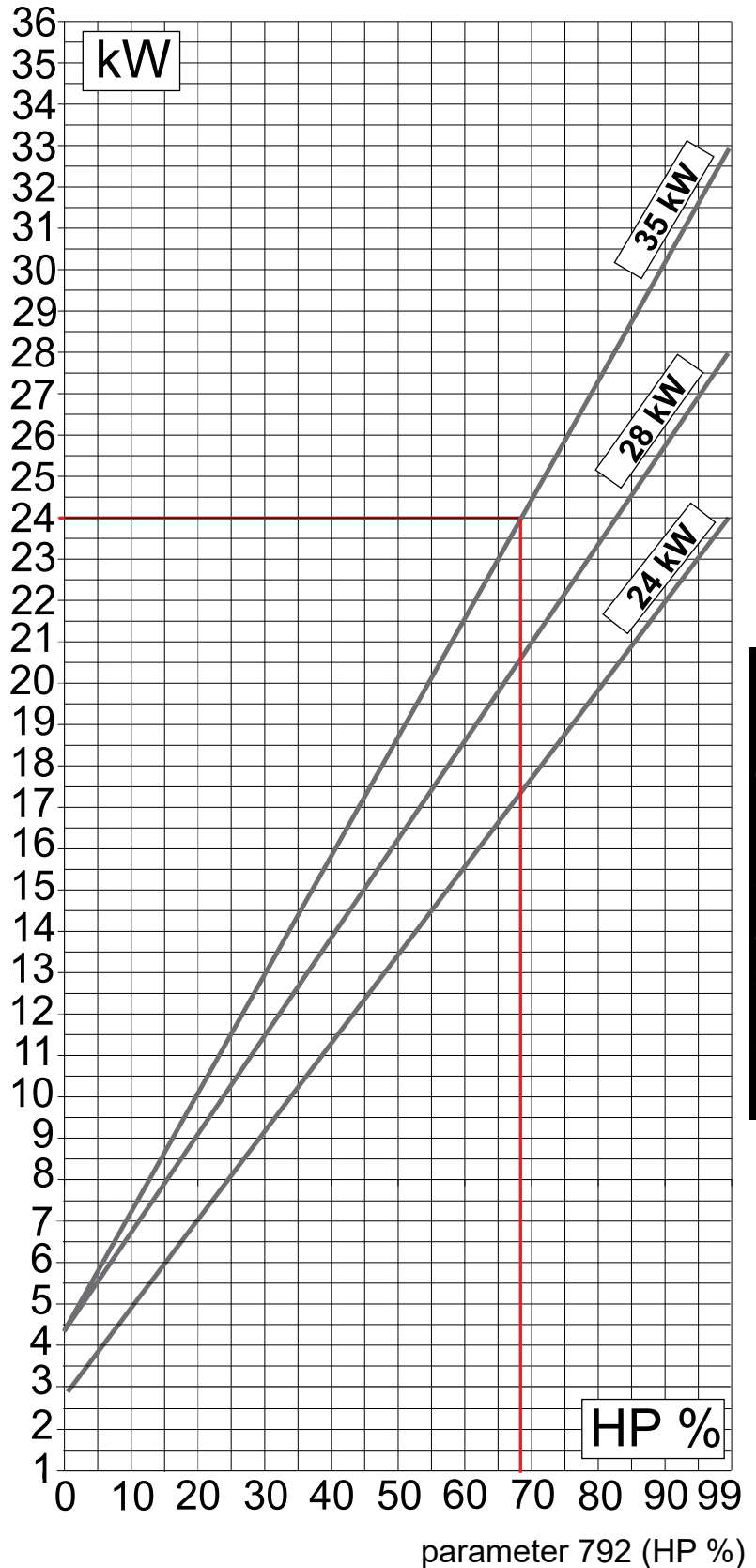

4

INSPECTIONS AND MAINTENANCE



Inspections and maintenance performed professionally and according to a regular schedule, as well as the use of original spare parts, are of the utmost importance for fault-free operation of the boiler and to guarantee its long life.

Yearly maintenance of the appliance is mandatory in compliance with Laws in force.



Failure to perform Inspections and Maintenance can entail material and personal damage.

4.1 - INSPECTION AND MAINTENANCE INSTRUCTIONS

To assure long-term functioning of your appliance and to avoid altering its approved status, only original Unical AG S.p.A. spare parts must be used.

If a component needs to be replaced:

- Disconnect the appliance from the electrical mains and make sure that it cannot be reconnected accidentally.
- Close the gas shut-off valve upstream the boiler.
- If needed, and depending on the intervention to be carried out, close any shut-off valves on the flow and return line of the heating system, as well as the cold water inlet valve.

- Remove the front casing from the appliance.

Once all maintenance operations are complete resume boiler operation

- Open the heating flow and return pipes, as well as the cold water inlet valve (if closed previously).
- Vent and, if necessary, restore the heating pressure until reaching a pressure of 0.8/1.0 bar.
- Open the gas shut-off valve.
- Switch the boiler back on.
- Make sure the appliance is gas tight and water-tight.
- Remount the front casing of the appliance.

TABLE OF RESISTANCE VALUES, ACCORDING TO THE TEMPERATURE, TO THE HEATING PROBE 11 (SR) AND TO THE DOMESTIC HOT WATER PROBE 1 (SS) AND ANY HEATING RETURN PROBE 22 (SRR) see par. 4.5.

T°C	0	1	2	3	4	5	6	7	8	9
0	32755	31137	29607	28161	26795	25502	24278	23121	22025	20987
10	20003	19072	18189	17351	16557	15803	15088	14410	13765	13153
20	12571	12019	11493	10994	10519	10067	9636	9227	8837	8466
30	8112	7775	7454	7147	6855	6577	6311	6057	5815	5584
40	5363	5152	4951	4758	4574	4398	4230	4069	3915	3768
50	3627	3491	3362	3238	3119	3006	2897	2792	2692	2596
60	2504	2415	2330	2249	2171	2096	2023	1954	1888	1824
70	1762	1703	1646	1592	1539	1488	1440	1393	1348	1304
80	1263	1222	1183	1146	1110	1075	1042	1010	979	949
90	920	892	865	839	814	790	766	744	722	701

Relation between the temperature (°C) and the nom. resistance (Ohm) of the heating probe SR and of the domestic hot water probe SS

Example: At 25°C, the nominal resistance is 10067 Ohm At 90°C, the nominal resistance is 920 Ohm

4.1.1- CONTROL PANEL Ufly BOX



Ufly BOX is hidden inside the boiler, to access it, rotate as indicated.



General Operating Instructions for Ufly-BOX, are contained in specific manual provided with the boiler.

This section only lists the steps required to

Adjustment / maintenance of the boiler:

- Chimney sweep function (Par. 3.11.1)
- Calibration (Par. 3.12.1)
- Edit parameters (Par. 4.2)
- Automatic calibration GAC Adaptive Calibration Gas (Par. 4.3.1)

ENGLISH

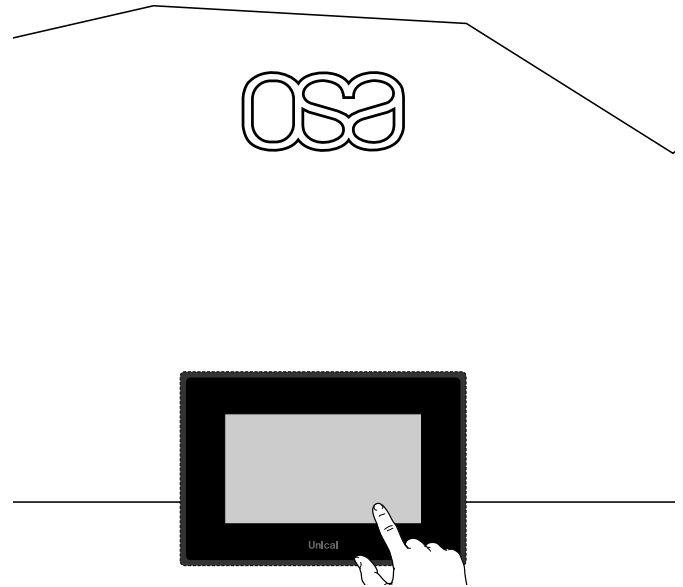
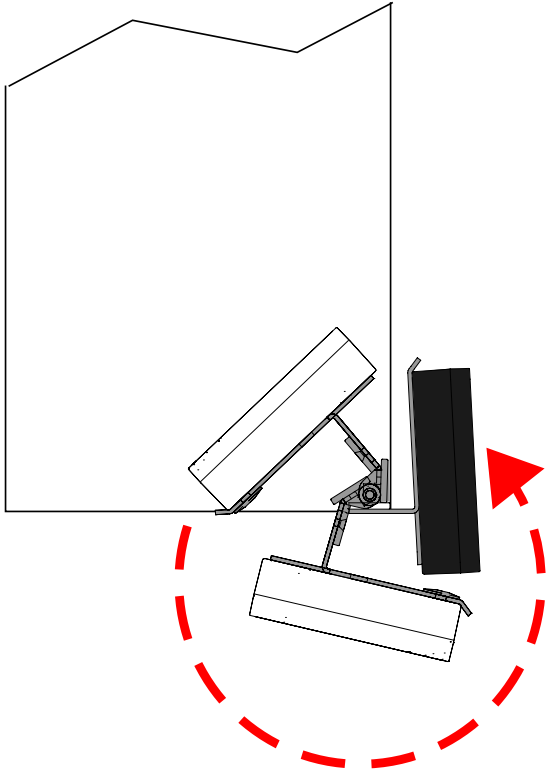

ROUTINE YEARLY VERIFICATION OPERATIONS		
COMPONENT:	VERIFY:	CONTROL/INTERVENTION METHOD:
FL (domestic hot water priority flow switch) (2)	Is the minimum domestic hot water flow rate 3 l/min.?	The burner must ignite with an intake above or equal to: 3 l/min.
VG (Gas valve) (3)	Does the valve modulate properly?	Open a hot water tap at maximum flow rate and then at minimum. Make sure that the flame modulates.
SR (heating sensor)(11) SS (domestic hot water sensor) (1) SSR (return sensor) (22)	Do the sensors maintain the original characteristics?	12571 ohm at 20° C / 1762 ohm at 70° C. Measurement to be taken with the wires disconnected (see table Res/Temp).
E ACC/RIV. (ignition/detection electrode) (4)	Does the discharge of sparks before putting the boiler in safe conditions last less than 10 sec.?	Detach the electrode ionisation wire and check the securing time.
TL (anti-overheating limit thermostat) (10)	Does the TL put the boiler in safety conditions when overheating?	Heat the TL until it intervenes at 95°C and check that it intervenes at 95°.
DK (safety pressure switch against water deficiency) (13)	Does the pressure switch block the boiler if the water pressure is below 0.4 bar?	Without request: close the shut-off valves of the heating circuit, open the drain valve to make the water pressure decrease. Before pressurising again, check the pressure of the expansion vessel.
Expansion vessel (8)	Does the vessel contain the right amount of air?	Check the pressure in expansion vessel (1 bar when the boiler is empty). Pressurise the boiler (open the pump automatic vent valve). Open the heating circuit closing valves.
Condensation drain trap (26)	Has the trap got deposits on the bottom?	Clean the trap with water.
Domestic hot water flow rate	Filter in cold water inlet (2)	Clean the filter with limescale remover.
Heat exchanger body (24)	1) Measure the Thermal Capacity using a meter and compare the value with that contained in table 3.12. The data measured indicates if the exchanger needs cleaning. 2) Check that the space between the rungs of the exchanger are not clogged	It is recommended to use the products purposely created by Unical (see system protection ACCESSORIES sect. in the domestic price list), being careful to wash the area with most rungs first (lowest part visible from above) and then the upper part if necessary.
Burner (5)	Check the state of cleanliness of the burner mesh	Remove any deposits using compressed air, blowing from the mesh side.
(Num) = see key Par. 2.2		

4.2 - PROGRAMMING OF THE OPERATION PARAMETERS

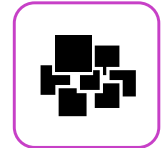

ENGLISH

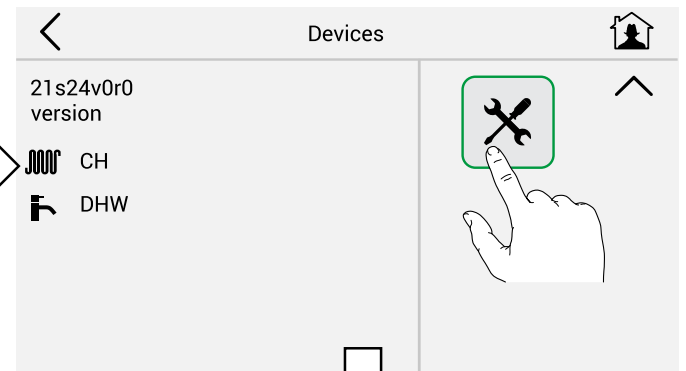
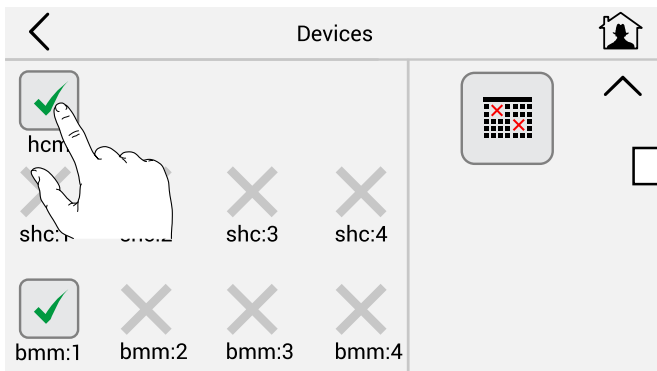
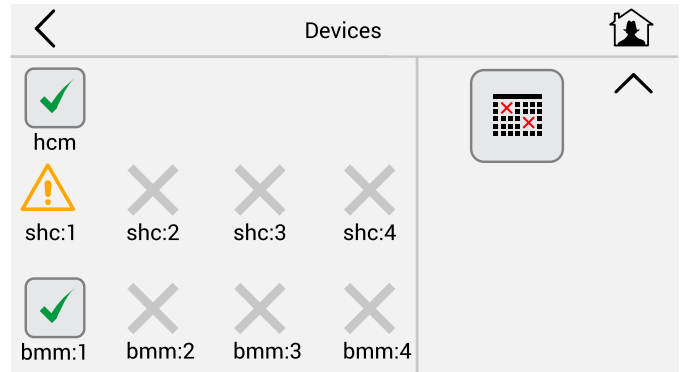
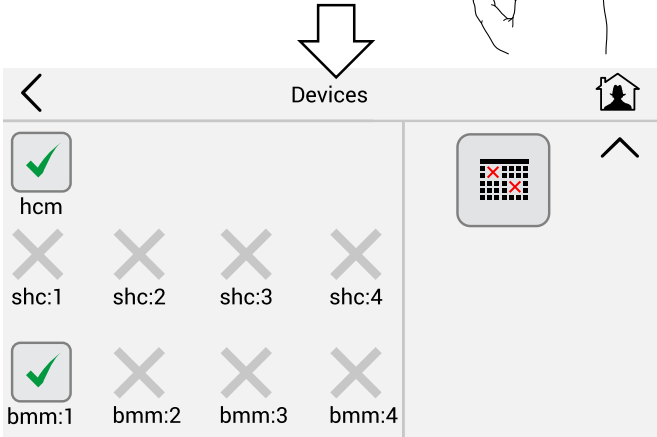
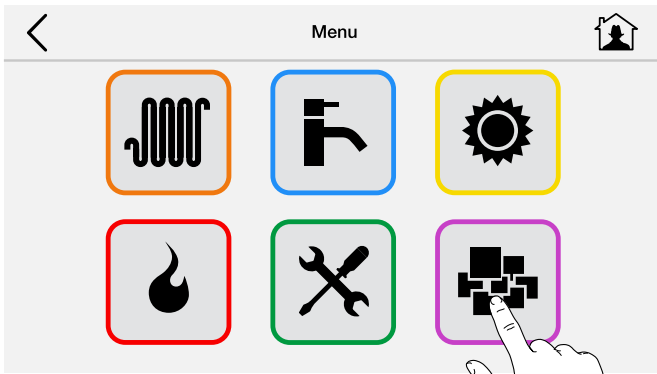

At every boiler lighting UFLY scans devices, if new devices are recognized, such as:

hcm / bcm	Heating / Burner Control Manager
shc	Slave Heating Controller Multifunction module
bmm	Burner Modul Manager

They are displayed on the next screen, and is prompted to save the new configuration.

	Icon scanning devices
	icon save new configuration

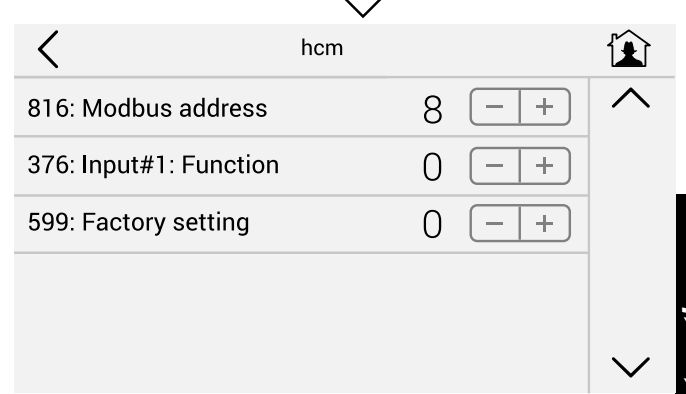

	Device detected
	Not installed device
	previously recognized device, but not detected.

Maintenance instructions

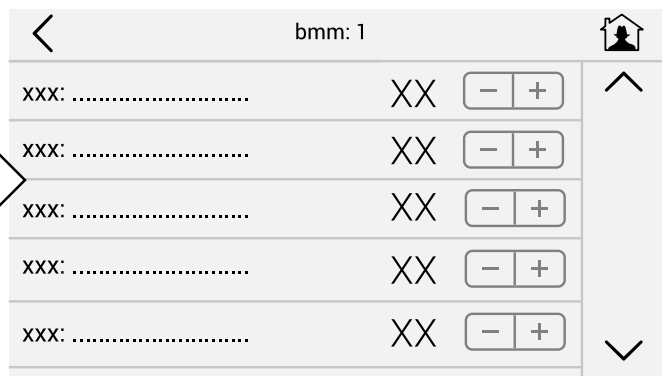
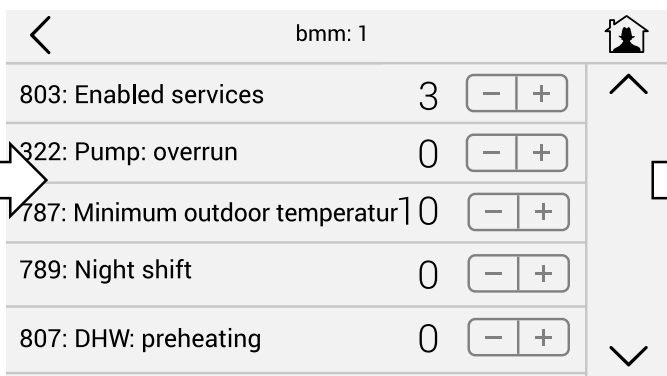
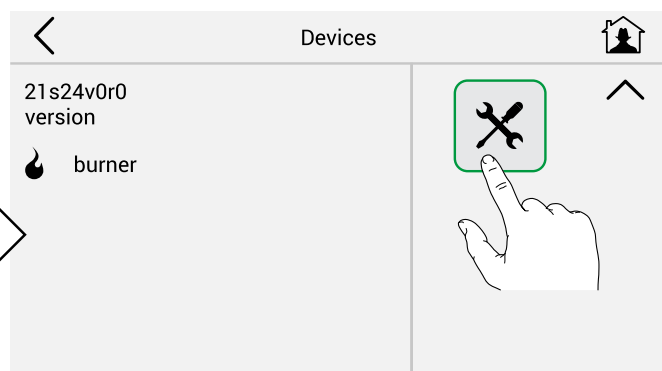
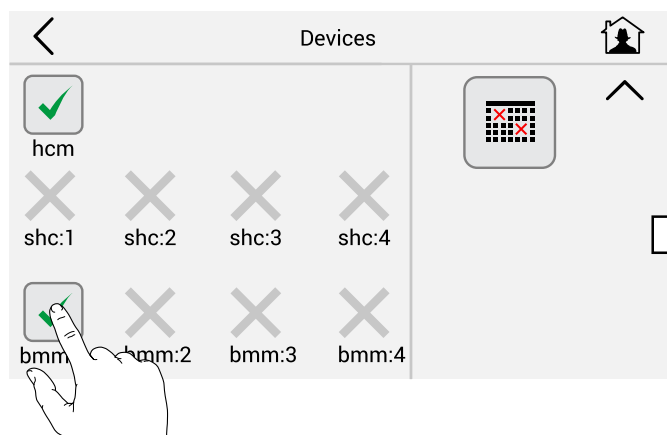
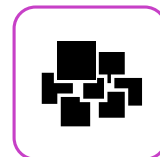

To change the parameters is required password.

Parametri				
Code	Description	Set.	Min.	Max.
803	Enabled Services: 0: CH & DHW disabled 1: CH enabled 2: DHW enabled 3: CH & DHW enabled	3	0	3
322	Pump: Post-circulation 0: overrun 5 min. 1: continuous	0	0	1
787	Outdoor minimum temp °C	10	0	30
789	Night shift °C 0: T.A. 5÷30: Value night shift	0	0/5	30
807	ACS Preheating	0	0	1
792	CH: Modulation max	100	0	100
31	CH#1 Minimum Set point	30	20	45

39	CH#1 Max. Set point	85	50	85
650	ACS Set point Min.	35	25	45
385	ACS Set point Max.	60	50	65
48	CH#1 Set point °C	70	20	85
832	Access Code (#)	0	0	199
To change the following parameters you must enable the access code.				
778	Burner: 0: G20 - 1 GPL	0	0	1
341	Pump: Minimum Control	--	0	100
313	Pump: Maximum Control	--	20	100
312	Pump: temp. diff. °C	--	5	20
775	Valvola Dev.: Stroke time sec.	--	0	6
309	System configurations: 1: W1 2: W2 3: W3 4: W4	--	1	4
771	Sensore pressione Acqua 0: assente - 1 presente	--	0	1

896	Unit: 0 = °C / bar 1 = °Fahrenheit / PSI	0	0	1
806	Frequency: 0: 50 Hz - 1: 60 Hz	0	0	1
848	Dis. local setpoint: 0: bidirectional 1: Only by remote	0	0	1
483	Temp. different. Max	1	0	1
672	Min modulation CH/ACS	0	0	100
2590	Burner power	--	0	9
619	Modulation and ignition	--	10	70

346	Fan min speed	(*)	0	199
319	fan max speed	(**)	0	199
353	Regolation Proportional	--	1	20
354	Regolation Integrative	--	1	20
478	Regolation Derivative	--	1	20
323	ACS PID:Proportional	--	1	20
324	ACS PID:Integrative	--	1	50
325	ACS PID:Derivative	--	1	20
(#) Enable (insert value) to change parameter				
(*) (x 10 + 750) = rpm x 100				
(**) (x 10 + 5000) = rpm x 100				

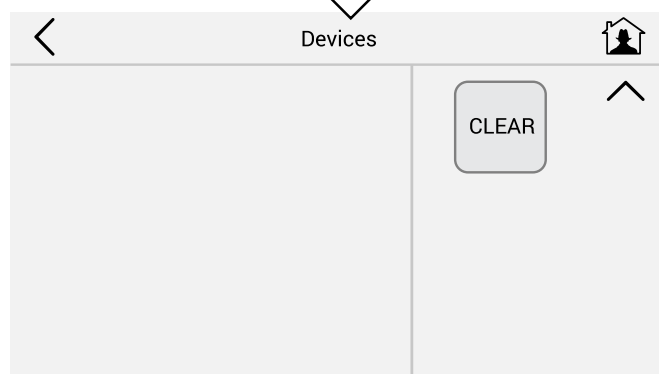
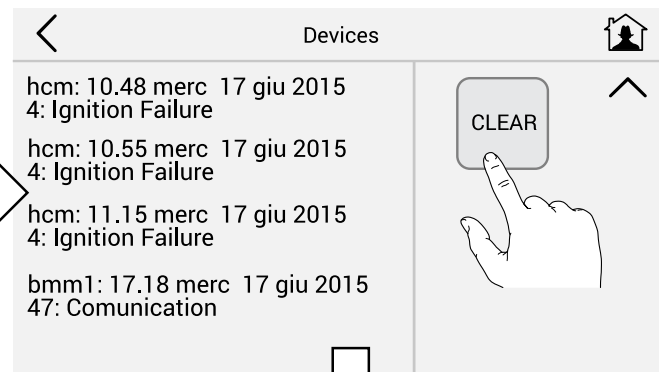
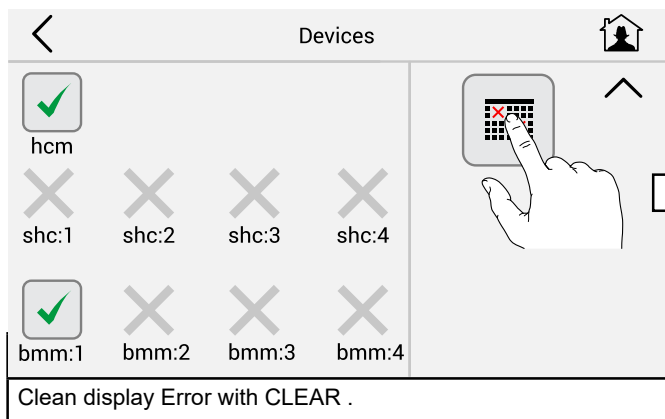

4.3 - ADAPTATION TO THE USE OF OTHER GAS

The boilers are produced for the type of gas specifically requested upon ordering.



DANGER!

The conversion for the operation of the boiler with a type of gas other than that specifically required in the order, must be performed by professionally qualified personnel, in compliance with the standards and regulations in force.

The manufacturer cannot be held liable for any damage resulting from a conversion operation that is incorrect or not performed in compliance with the laws in force and/or with the instructions given.



ATTENTION!

After performing the conversion for the operation of the boiler with a type of gas (e.g. propane gas) other than that specifically requested when ordering, the appliance will only work with this new type of gas.



ATTENTION!

Indications for propane gas-fired appliances

Make sure that the gas tank has been deaerated before installing the appliance.

For state-of-the-art deaeration of the tank, contact the LPG supplier or a person qualified in compliance with law.

If the tank has not been professionally deaerated, ignition problems could arise.

In that case, contact the supplier of the LPG tank.

Gas Conversion

NOTE!

For more information
See Technical Info
from site indicated at pag. 2

In order to change the gas one must change the Factory parameter:

PARAMETER par 4.2		
CODE	GAS NAT.	PROPANE
778	0	1



Once the 778 parameter has been edited one must perform the GAC automatic calibration (Gas Adaptive Calibration) Chapter 4.3.1

- when the conversion is complete, fill in the information required on the label supplied in the documentation envelope and apply it next to the technical data label of the boiler.

EXAMPLE OF COMPILATION

	Data - Fecha Date - Datum	08, 09, 05
	Firma - Signature Unterschrift	
- Regolata per	G 20	<input type="checkbox"/>
- Réglée pour	G 25	<input type="checkbox"/>
- Adjusted for	G 30	<input type="checkbox"/>
- Reglada para	G 31	<input checked="" type="checkbox"/>
- Eingestellt für		<input checked="" type="checkbox"/>

ETI 4530C

4.3.1 - GAC AUTOMATIC CALIBRATION

One can perform the GAC in domestic hot water mode as well.

Make sure that there are no heating requests present and that all the valves of the heating system are open.

If during this stage one wishes to disperse the heat on the domestic hot water circuit, open at least 2 hot water taps (ONLY AFTER HAVING ACTIVATED THE GAC FUNCTION).



WARNING!
Function reserved exclusively to authorized service centers.

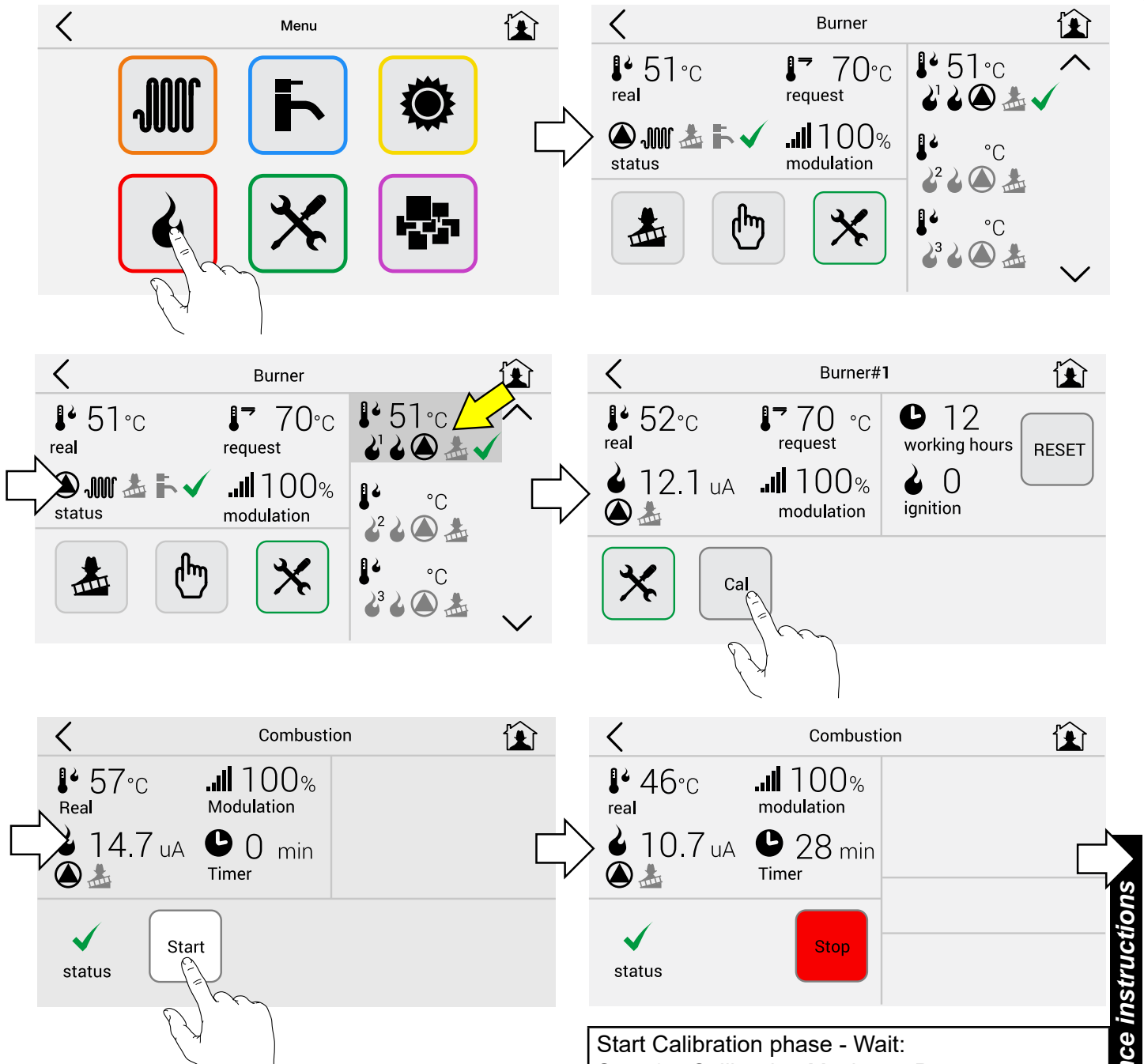

Step 1: CALIBRATION MAX POWER

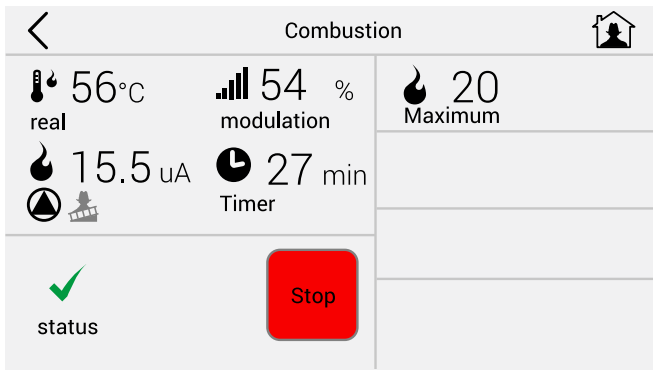

Step 2: CALIBRATION POWER START

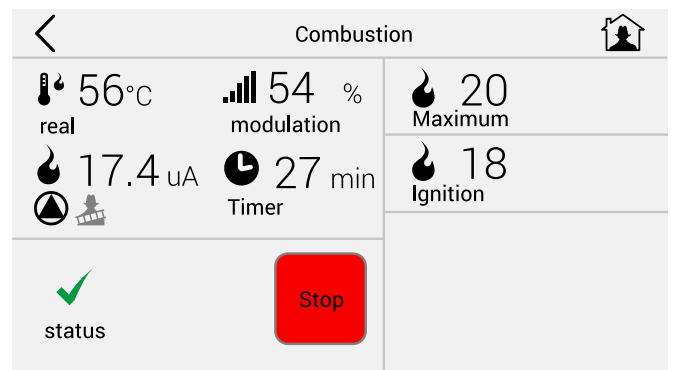

Step 3: CALIBRATION MIN POWER

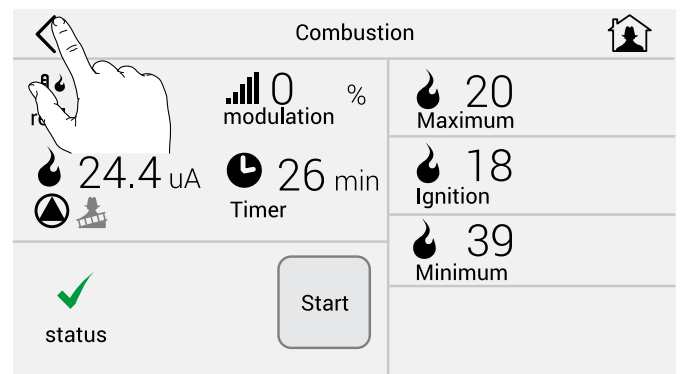
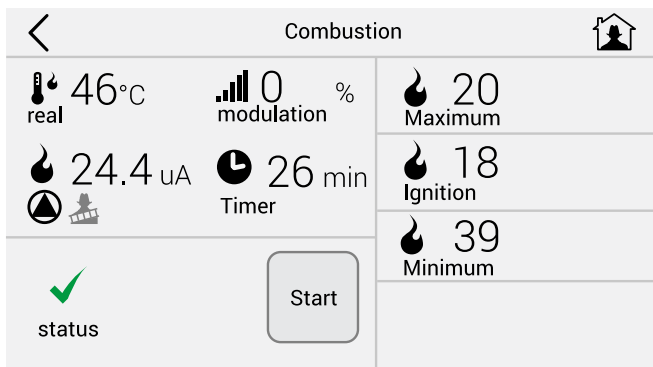

The automatic calibration is completed.

To perform the calibration adjustment of combustion, see par. 3.12.1.

(This page is intentionally left blank)

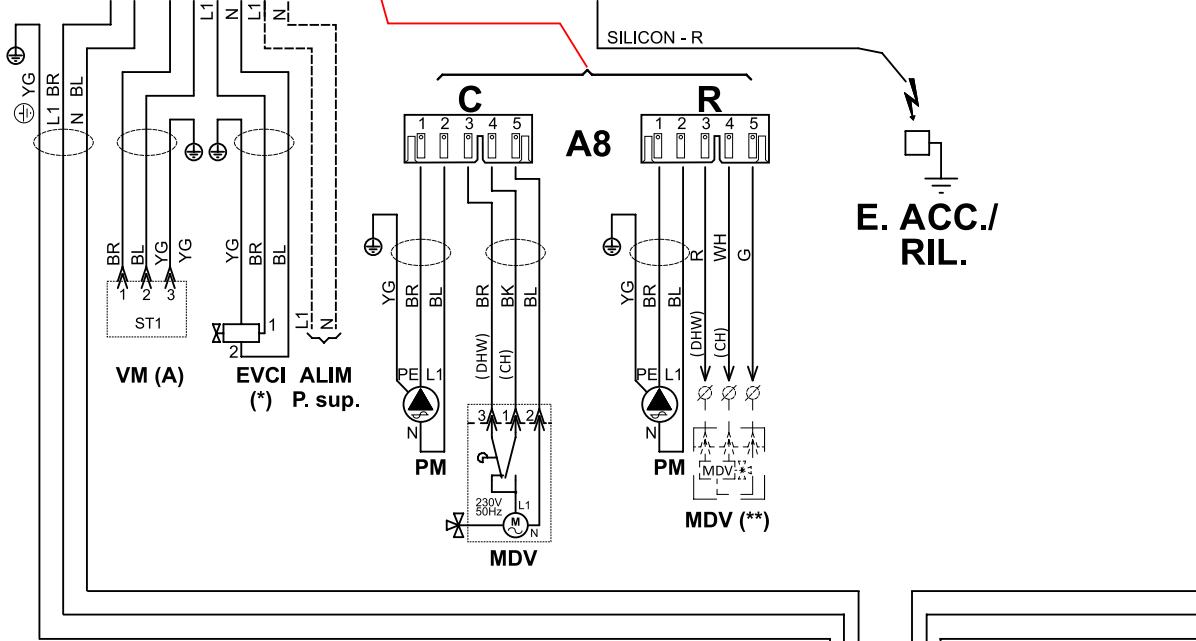
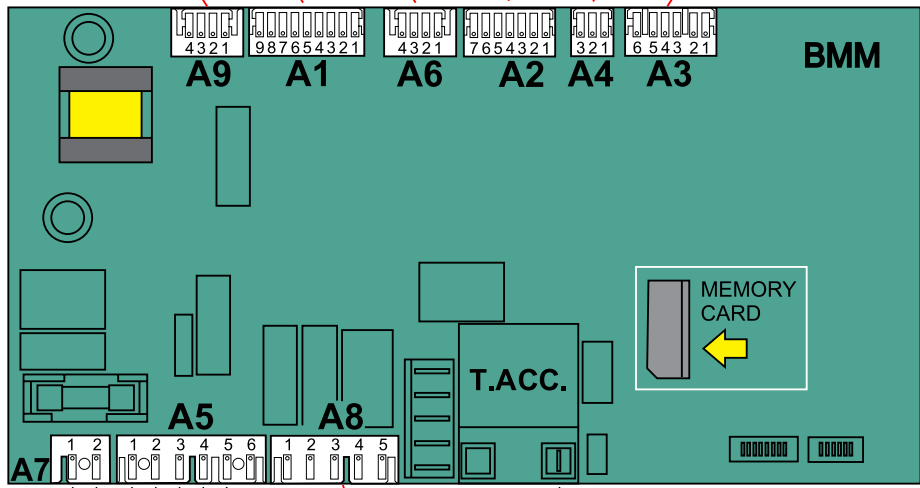
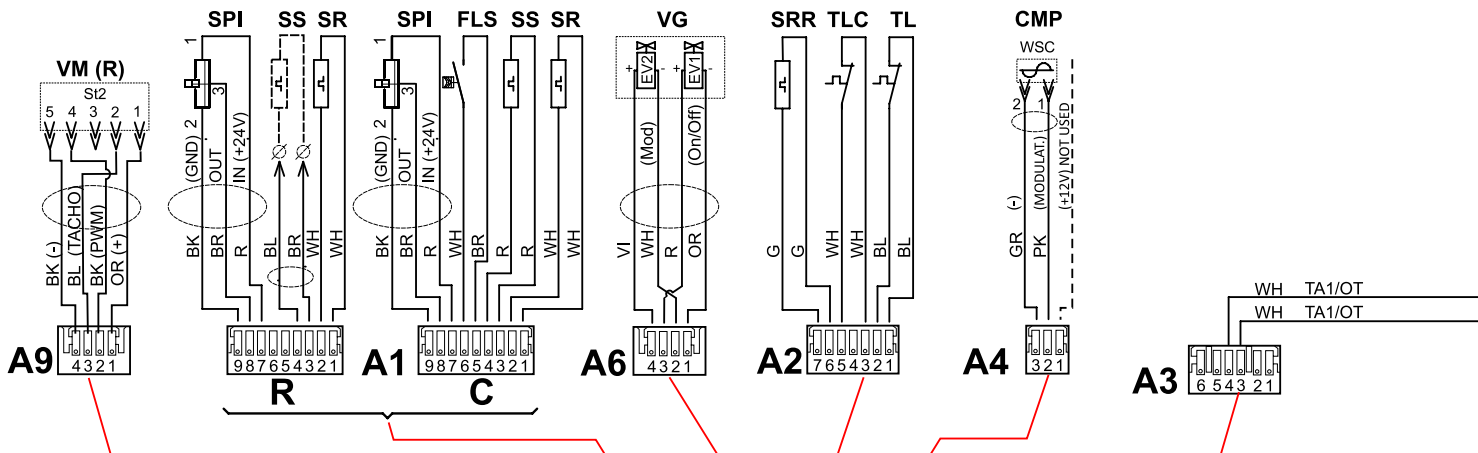

KEY	
BOARD BMM	
A1.....A9	Services connectors
ALIM. P. sup	Supply. Pump Extra
CMP	Control modulating Pump
E. ACC./RIL	Ignition/detection electrode
EVCI (*)	Caricamento Impianto (Only OSA S)
FLS	Domestic hot water request flow switch
MEMORY CARD	Memory

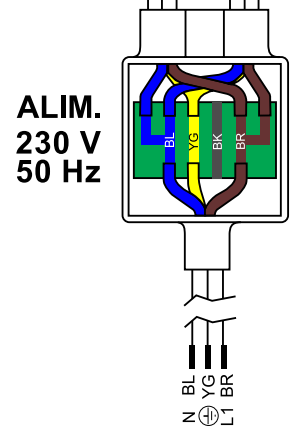

4.4 - WIRING DIAGRAM

Practical connection board

ENGLISH

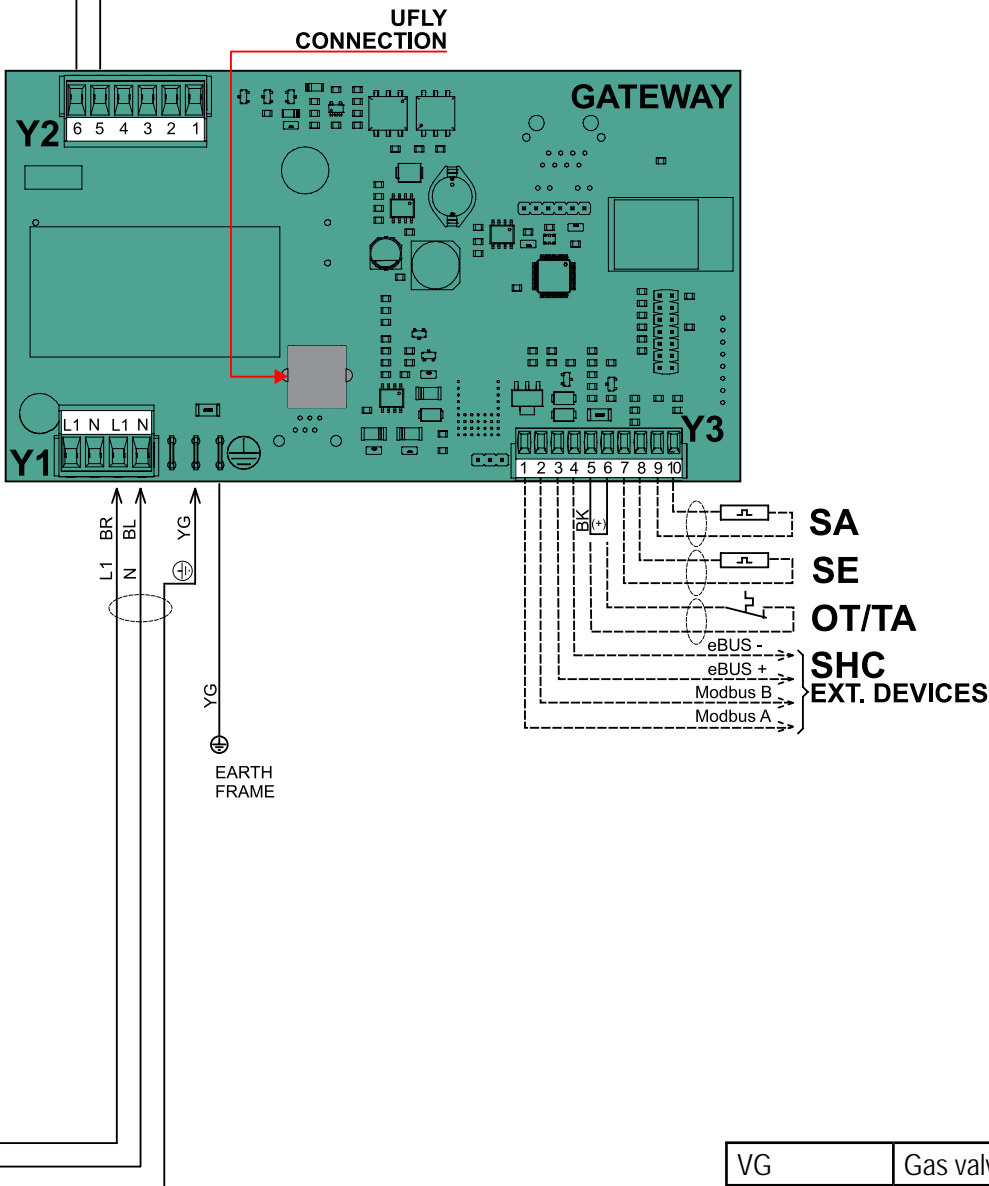

COLORS	
BL	BLUE
BR	BROWN
BK	BLACK
G	GREEN
GR	GREY
L BL	LIGHT BLUE
OR	ORANGE
PK	PINK
R	RED
Y	YELLOW
YG	YELL/GREEN
WH	WHITE
VI	VIOLET

MVD	Diverter valve motor
MDV (**)	Control predisposition diverter (external water heater) only Heating boilers
PM	Circolatore Modulante
SPI	Pressure Sensor System
SR	Flow heating sensor
SRR	Return heating sensor
SS	Domestic hot water probe (Pred. for R models)
TL	Limit thermostat
TLC	Flue gas collector limit thermostat

VG	Gas valve
VM (A)	Supply modulating fan
VM (R)	Rilev./Reg. Modulating Fun
Scheda GATEWAY	
Y1....Y3	Services connectors
230 V - 50 Hz	Boiler Supply
EXT DEVICE	External devices: SHC (eBUS+/-eBUS-)
SA	Terminal Room sensor
SE	Terminal Outer sensor
OT/TA	Terminal TA on-off / OT disabled)
UFLY connection	U-fly BOX supply

Maintenance instructions

4.5 - ERROR CODES

18:28 mon 9 nov 2015 Unical

41 °C real	0 °C request	HCM: 4 Ignition failure
0/1 burner	100% modulation	 status
RESET	MENU	

Failure that causes the stop of the boiler:

- The error code is displayed, the boiler is in lock. After resolving the fault press Reset to restart the boiler.

18:28 mon 9 nov 2015 Unical

41 °C real	0 °C request	HCM: 0 Regular operation
0/1 burner	100% modulation	 status
RESET	MENU	

Failure that could NOT cause stop of the boiler:

- Error code is displayed, the boiler is in CH demand, Icon Reset (note that was detected a fault even if the fault was temporary. Is therefore necessary always push reset to clear the display' "error"

ERROR CODES (FAULT)		(Num) = see key Par. 2.2
CODE	DESCRIPTION	SOLUTIONS
01	SAFETY THERMOSTAT Intervention of the safety thermostat (10)	Press Reset and/or check that the thermostat or its connections are not interrupted.
04	BLOCK No gas or failed burner ignition	Check the gas supply or that the ignition/detection electrode is working properly (4).
06	High Temperature Boiler temperature too high	Check pump operation and if needed clean the exchanger (24)
08	Water Deficiency Insufficient water pressure and consequent intervention of the minimum water pressure - pressure switch (13).	Fill the heating circuit as described in chap. 3.8 and wait for the values to return within default limits. If needed, check the electrical connections and replace the minimum water pressure switch.
09	Outer Sensor	Check the wiring, if needed replace outer sensor
10	Internal failure	
11	Parasite Flame Flame detected upon ignition	Check the wiring of the Ign/Det. electrode and remove any oxidation. Check for humidity between drain wire and ceramic, if necessary, replace the electrode, press the unblock key, if the anomaly persists, replace the electrode (4).
12	Heating Sensor (11) Heating sensor fault	Check the efficiency of the sensor (see table Res/Temp) (Par.4) or its connections.
13	Domestic Hot Water Sensor Domestic hot water sensor fault (1)	Check the efficiency of the sensor (see table Res/Temp) (Par.4) or its connections..
14	Inlet temperature Sensor (SRR)	Check the efficiency of the sensor / and replace it
15	Water circulation insufficient Primary circuit water circulation insufficient ($\Delta t > 35^{\circ} \text{C}$)	Check pump operation (12) and speed - remove any heating system obstructions - clean the scaled domestic hot water exchanger

16	Exchanger Freezing (24) Exchanger freezing is detected If the heating sensor detects a temperature below 2° C, burner ignition is inhibited until the sensor detects a temperature above 5°C	Disconnect the from the power supply, close the gas valve, defrost the exchanger carefully.
20	Parasite Flame Flame detected after swtich-off	Check the wiring and for any leaks from the gas valve (3), if needed replace the gas valve.
24	Speed out of control Check fan operation (18) and the connections	Check fan operation (18) and the connections
25	Exhaust smoke overheating	
26	Speed out of control Alteration of the fan speed; the speed is above that requested	Check fan operation (18) and the connections
28	Scambiatore Ostruito	
30	Service Parameter Service parameters altered due to possible electromagnetic interferences.	Reset and via Ufly restore the altered parameters
31	System configuration invalid or corrupted	
32	Low line voltage	Correction: if the line voltage is <190 Vac: the line voltage is really below the minimum limit, otherwise the line monitor error: replace BMM
38	Factory Parameters Alteration of the factory parameters due to possible electromagnetic interferences.	Press RESET; if the anomaly persists, replace the board.
44	Water sensor pressure detected if the pressure Transducer is present	Wait for the values to return to default limits / Replace the Transducer
45	Water Overheater detected if the H ₂ O pressure Transducer is present with pressure > 2.5 bar; it is reset automatically when H ₂ O pressure < 2 bar	Wait for the values to return to default limits / Replace the Transducer
47	Communication error	
49	HCM, SHC: host controller missing	
50	Room1: temperature sensor	
56	Host controller missing	
57	Burners NOT detected	
58	Global flow temperature sensor	
60	Date and Time not valid	
62	Actuators SGV	
66	Missing calibration	
74	Temp. sensors swap	
75	Temperature slope exceeds the limit	

94	Gas valve wiring	
95	Frequent loss of flame	
99	Internal error	
100	General Lockout not listed	
101	Ignition failure	
102	Short circuit of the iono electrode	
103	Gas valve open delay	

4.5.1 - FILL THE SYSTEM

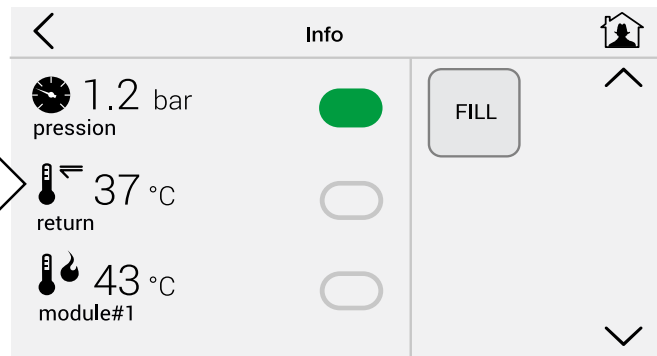
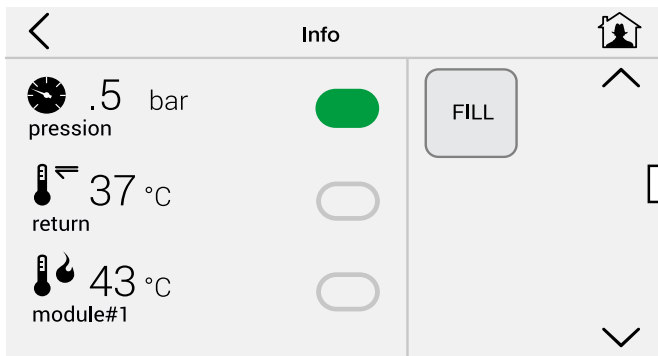
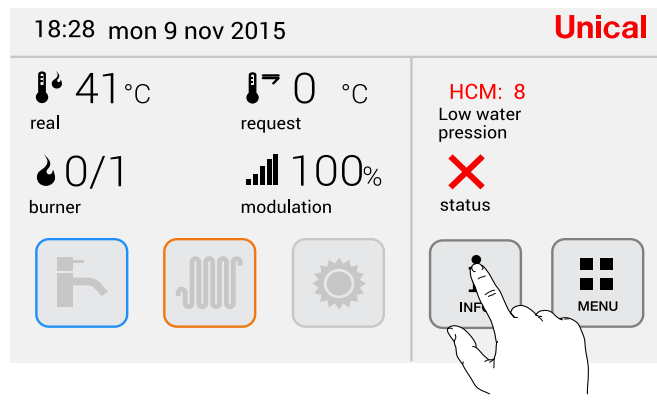
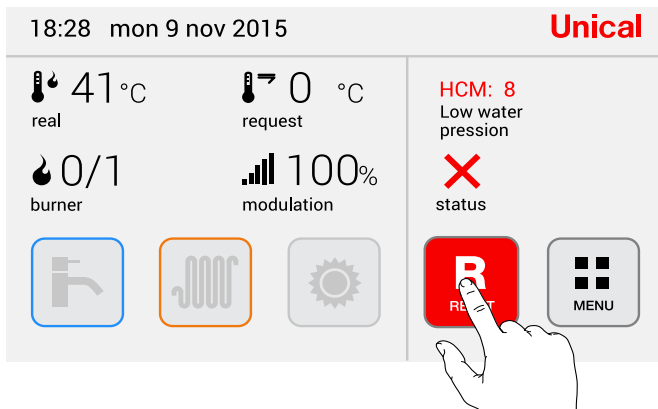

By pressing reset icon, start the automatic filling, up to a pressure of 1.2 bar (60 sec. max).

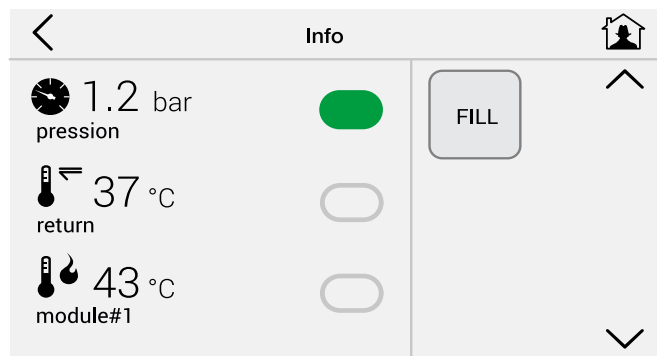
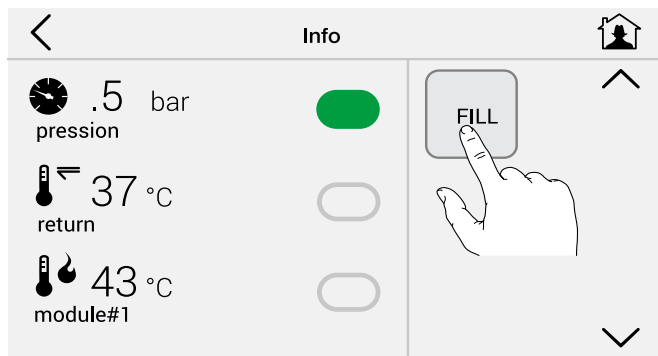

If the system does not reach 1.2 bar pressure within 60 seconds, activate the fill manually by pressing LOAD icon.

4.6 - IMPORTANT NOTES REPLACING COMPONENTS

Before replacing components one must follow the notes of chap. 4 "Inspections and maintenance".

To replace the components:
<ul style="list-style-type: none"> - GAS VALVE - FAN - BURNER, - IGNITION/DETECTION ELECTRODE, - MODULATION BOARD (in the event the memory board CANNOT be reused) (*),
GAC calibration is required

MODULATION BOARD		
A	universal board	
B	memory board (*)	<p>The memory board is programmed by default for METHANE gas operation. In the event of LPG operation the 778 parameter must be edited (Factory parameters), see (Chap. 4.2).</p>
<p>(*) In the event the memory board can be re-used, there is no need to reprogram parameters, settings and automatic calibration.</p>		

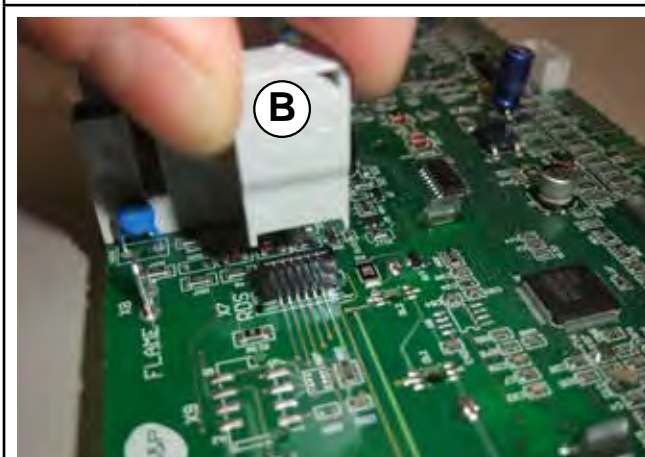
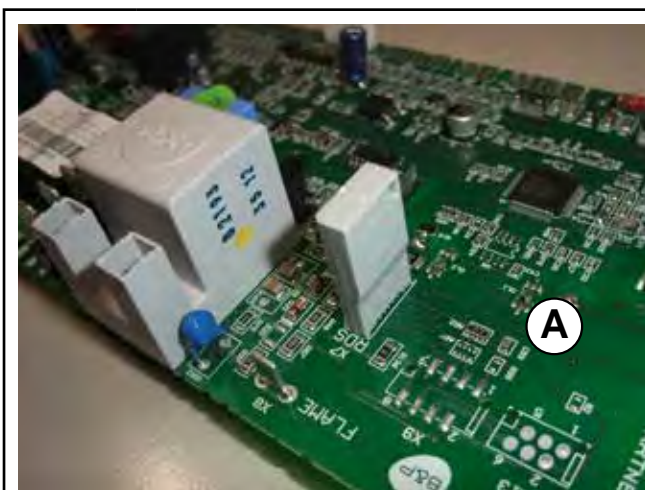

 Act carefully, pay attention to the insertion direction of the memory board.

4.6.1 - SERVICE PANEL

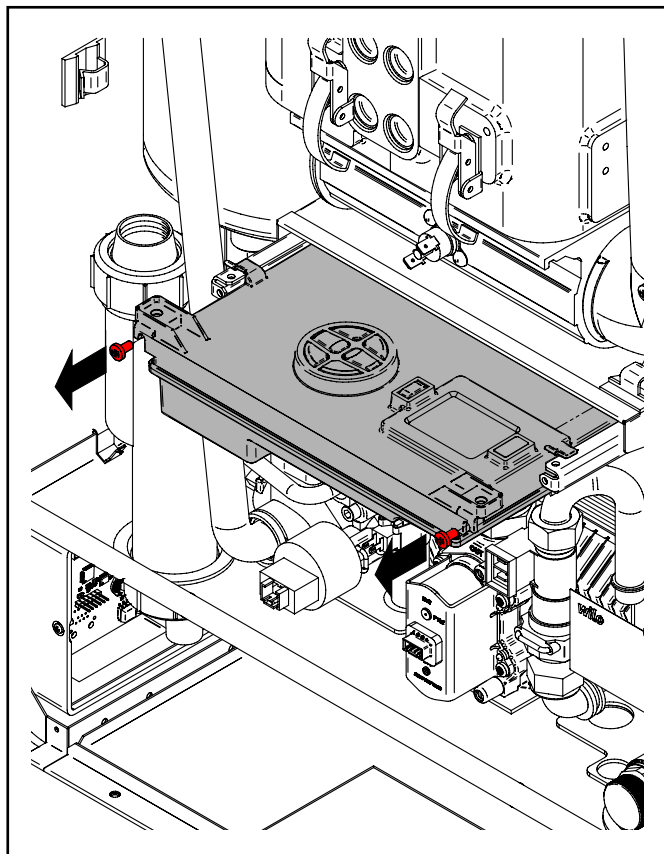

The boiler can be programmed also by means of the service inner panel. Remove the screws indicated to extract the panel and turn.



Indications related to programming with the emergency panel, can be found at the address indicated on page 2, or on the user / installation manual and maintenance of KONE model boiler.

Unical[®]



www.unical.eu

00336315 - 2nd ed. 05/21

Unical AG S.p.A. 46033 casteldario - mantova - italia - tel. +39 0376 57001 - fax +39 0376 660556
info@unical-ag.com - export@unical-ag.com - www.unical.eu

Unical declines every responsibility for the possible inaccuracies if owed to errors of transcript or press.
Also reserves the right to bring those changes that it will hold necessary to its own products or profits, without jeopardizing its essential characteristics.