

**TOSHIBA**  
Leading Innovation >>>

FILE NO. A09-011

# SERVICE MANUAL

# AIR-CONDITIONER

## SPLIT TYPE

***RAS-M10PKVP-E, RAS-M13PKVP-E,  
RAS-M16PKVP-E, RAS-M18PKVP-E /  
RAS-5M34UAV-E***

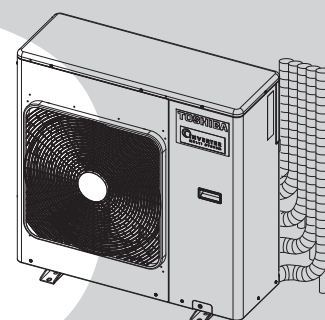
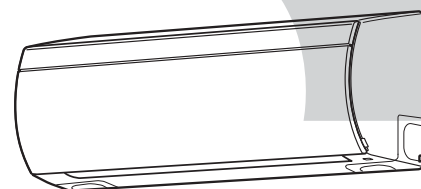



# CONTENTS

1. SAFETY PRECAUTIONS .....	3
2. SPECIFICATIONS .....	5
3. REFRIGERANT R410A .....	26
4. CONSTRUCTION VIEWS .....	34
5. WIRING DIAGRAM .....	36
6. SPECIFICATIONS OF ELECTRICAL PARTS .....	38
7. REFRIGERANT CYCLE DIAGRAM.....	39
8. CONTROL BLOCK DIAGRAM .....	46
9. OPERATION DESCRIPTION .....	48
10. INSTALLATION PROCEDURE .....	74
11. HOW TO DIAGNOSE THE TROUBLE .....	93
12. HOW TO REPLACE THE MAIN PARTS .....	121
13. EXPLODED VIEWS AND PARTS LIST.....	141

# 1. SAFETY PRECAUTIONS



The important contents concerned to the safety are described on the product itself and on this Service Manual. Please read this Service Manual after understanding the described items thoroughly in the following contents (Indications/Illustrated marks), and keep them.

## [Explanation of indications]

Indication	Explanation
 <b>DANGER</b>	Indicates contents assumed that an imminent danger causing a death or serious injury of the repair engineers and the third parties when an incorrect work has been executed.
 <b>WARNING</b>	Indicates possibilities assumed that a danger causing a death or serious injury of the repair engineers, the third parties, and the users due to troubles of the product after work when an incorrect work has been executed.
 <b>CAUTION</b>	Indicates contents assumed that an injury or property damage (*) may be caused on the repair engineers, the third parties, and the users due to troubles of the product after work when an incorrect work has been executed.

\* Property damage : Enlarged damage concerned to property, furniture, and domestic animal/pet

## [Explanation of illustrated marks]

Mark	Explanation
	Indicates prohibited items (Forbidden items to do) The sentences near an illustrated mark describe the concrete prohibited contents.
	Indicates mandatory items (Compulsory items to do) The sentences near an illustrated mark describe the concrete mandatory contents.
	Indicates cautions (including danger/warning) The sentences or illustration near or in an illustrated mark describe the concrete cautious contents.

## For general public use

Power supply cord of outdoor unit shall be more than 2.5 mm<sup>2</sup> (H07RN-F or 60245IEC66) polychloroprene sheathed flexible cord.

- Read this “SAFETY PRECAUTIONS” carefully before servicing.
- The precautions described below include the important items regarding safety. Observe them without fail.
- After the servicing work, perform a trial operation to check for any problem.
- Turn off the main power supply switch (or breaker) before the unit maintenance.

 **CAUTION**

## New Refrigerant Air Conditioner Installation

- **THIS AIR CONDITIONER ADOPTS THE NEW HFC REFRIGERANT (R410A) WHICH DOES NOT DESTROY OZONE LAYER.**

R410A refrigerant is apt to be affected by impurities such as water, oxidizing membrane, and oils because the working pressure of R410A refrigerant is approx. 1.6 times of refrigerant R22. Accompanied with the adoption of the new refrigerant, the refrigeration machine oil has also been changed. Therefore, during installation work, be sure that water, dust, former refrigerant, or refrigeration machine oil does not enter into the new type refrigerant R410A air conditioner circuit.

To prevent mixing of refrigerant or refrigerating machine oil, the sizes of connecting sections of charging port on main unit and installation tools are different from those used for the conventional refrigerant units.

Accordingly, special tools are required for the new refrigerant (R410A) units. For connecting pipes, use new and clean piping materials with high pressure fittings made for R410A only, so that water and/or dust does not enter. Moreover, do not use the existing piping because there are some problems with pressure fittings and possible impurities in existing piping.

---

 **CAUTION**

---

**TO DISCONNECT THE APPLIANCE FROM THE MAIN POWER SUPPLY**

A switch or circuit breaker that can disconnect all poles must be included in the fixed wiring.

Be sure to use an approved circuit breaker or switch.

---

---

 **DANGER**

---

- **Ask an authorized dealer or qualified installation professional to install/maintain the air conditioner.** INAPPROPRIATE SERVICING MAY RESULT IN WATER LEAKAGE, ELECTRIC SHOCK OR FIRE.
- TURN OFF MAIN POWER SUPPLY BEFORE ATTEMPTING ANY ELECTRICAL WORK. MAKE SURE ALL POWER SWITCHES ARE OFF. FAILURE TO DO SO MAY CAUSE ELECTRIC SHOCK.

---

 **DANGER: HIGH VOLTAGE**

---

The high voltage circuit is incorporated.

Be careful to do the check service, as the electric shock may be caused in case of touching parts on the P.C. board by hand.

---

- CORRECTLY CONNECT THE CONNECTING CABLE. IF THE CONNECTING CABLE IS INCORRECTLY CONNECTED, ELECTRIC PARTS MAY BE DAMAGED.
  - CHECK THAT THE EARTH WIRE IS NOT BROKEN OR DISCONNECTED BEFORE SERVICE AND INSTALLATION. FAILURE TO DO SO MAY CAUSE ELECTRIC SHOCK.
  - DO NOT INSTALL NEAR CONCENTRATIONS OF COMBUSTIBLE GAS OR GAS VAPORS. FAILURE TO FOLLOW THIS INSTRUCTION CAN RESULT IN FIRE OR EXPLOSION.
  - TO PREVENT THE INDOOR UNIT FROM OVERHEATING AND CAUSING A FIRE HAZARD, PLACE THE UNIT WELL AWAY (MORE THAN 2 M) FROM HEAT SOURCES SUCH AS RADIATORS, HEAT RESISTORS, FURNACE, STOVES, ETC.
  - WHEN MOVING THE AIR-CONDITIONER FOR INSTALLATION IN ANOTHER PLACE, BE VERY CAREFUL NOT TO ALLOW THE SPECIFIED REFRIGERANT (R410A) TO BECOME MIXED WITH ANY OTHER GASEOUS BODY INTO THE REFRIGERATION CIRCUIT. IF AIR OR ANY OTHER GAS IS MIXED IN THE REFRIGERANT, THE GAS PRESSURE IN THE REFRIGERATION CIRCUIT WILL BECOME ABNORMALLY HIGH AND IT MAY RESULT IN THE PIPE BURSTING AND POSSIBLE PERSONNEL INJURIES.
  - IN THE EVENT THAT THE REFRIGERANT GAS LEAKS OUT OF THE PIPE DURING THE SERVICE WORK AND THE INSTALLATION WORK, IMMEDIATELY LET FRESH AIR INTO THE ROOM. IF THE REFRIGERANT GAS IS HEATED, SUCH AS BY FIRE, GENERATION OF POISONOUS GAS MAY RESULT.
- 

---

 **WARNING**

---

- **Never modify this unit by removing any of the safety guards or bypass any of the safety interlock switches.**
  - **Do not install in a place which cannot bear the weight of the unit.**  
**Personal injury and property damage can result if the unit falls.**
  - **After the installation work, confirm that refrigerant gas does not leak.**  
If refrigerant gas leaks into the room and flows near a fire source such as a cooking range, noxious gas may generate.
  - **The electrical work must be performed by a qualified electrician in accordance with the Installation Manual. Make sure the air conditioner uses an exclusive circuit.**  
An insufficient circuit capacity or inappropriate installation may cause fire.
  - **When wiring, use the specified cables and connect the terminals securely to prevent external forces applied to the cable from affecting the terminals.**
  - **Be sure to provide grounding.**  
Do not connect ground wires to gas pipes, water pipes, lightning rods or ground wires for telephone cables.
  - **Conform to the regulations of the local electric company when wiring the power supply.**  
Inappropriate grounding may cause electric shock.
-



## CAUTION

- Exposure of unit to water or other moisture before installation may result in an electrical short. Do not store in a wet basement or expose to rain or water.
- Do not install in a place that can increase the vibration of the unit. Do not install in a place that can amplify the noise level of the unit or where noise or discharged air might disturb neighbors.
- To avoid personal injury, be careful when handling parts with sharp edges.
- **Perform the specified installation work to guard against an earthquake.**  
If the air conditioner is not installed appropriately, accidents may occur due to the falling unit.

## 2. SPECIFICATIONS

The indoor and outdoor units that can be used in combination are shown in the tables below.

**Table of models that can be connected**

Type	Outdoor unit	Indoor unit			
Heat pump	RAS-5M34UAV-E	RAS-M10PKVP-E	RAS-M13PKVP-E	RAS-M16PKVP-E	RAS-M18PKVP-E
		RAS-M10PKVP-ND	RAS-M13PKVP-ND	RAS-M16PKVP-ND	RAS-M18PKVP-ND
		RAS-B10UFV-E	RAS-B13UFV-E	RAS-B18UFV-E	
		RAS-M07SKV-E	RAS-M10SKV-E	RAS-M13SKV-E	RAS-M16SKV-E
		RAS-M10GDV-E	RAS-M13GDV-E	RAS-M16GDV-E	
		RAS-M10SMUV-E	RAS-M13SMUV-E	RAS-M16SMUV-E	

**Table of models that can be used in combination**

Type	Outdoor unit	Combinations of indoor unit models that can be connected
Heat pump	RAS-5M34UAV-E	Refer to page 7 to 18

### NOTES

A 1-room connection is not an option for the indoor units (you cannot connect only one indoor unit).  
Be sure to connect indoor units in two or more.

The contents noted in this service manual limit the indoor units to the RAS-M10PKVP-E, RAS-M13PKVP-E, RAS-M16PKVP-E, RAS-M18PKVP-E.

For other indoor units that can also be used in combination, see the Service Manual of each indoor unit.

Indoor unit		File No.
RAS-M07SKV-E RAS-M10SKV-E RAS-M13SKV-E	RAS-M16SKV-E	SVM-07034
RAS-M10GDV-E RAS-M13GDV-E RAS-M16GDV-E		A05-010
RAS-B10SKVP-E RAS-B13SKVP-E RAS-B16SKVP-E		A06-014
RAS-M10SMUV-E RAS-M13SMUV-E RAS-M16SMUV-E		A06-015

## 2-1. Specifications

### <Heat Pump Models>

#### RAS-M10PKVP-E, RAS-M13PKVP-E, RAS-M16PKVP-E, RAS-M18PKVP-E / RAS-5M34UAV-E

Unit model		Indoor	RAS-	M10PKVP-E, M13PKVP-E, M16PKVP-E, M18PKVP-E			
		Outdoor	RAS-	5M34UAV-E			
Cooling Capacity		(kW)		10.0			
Cooling Capacity range		(kW)		11.0			
Heating Capacity		(kW)		12.0			
Heating Capacity range		(kW)		14.0			
Power supply		220-240V 1Ph 50Hz / 220V 1Ph 60Hz					
Electric characteristics	Indoor	Unit model	RAS-	M10PKVP-E	M13PKVP-E	M16PKVP-E	M18PKVP-E
		Running current	(A)	0.21 / 0.20 / 0.19	0.24 / 0.23 / 0.22	0.27 / 0.26 / 0.25	0.30 / 0.29 / 0.28
		Power Consumption	(W)	25	30	35	40
		Power factor	(%)	54 / 54 / 55	57 / 57 / 57	59 / 59 / 58	61 / 60 / 60
	Total	Unit model	RAS-	5M34UAV-E			
		Operation mode		Cooling		Heating	
		Running current	(A)	13.99 / 13.38 / 12.82		13.56 / 12.97 / 12.43	
		Power consumption	(W)	2923		2833	
		Power factor	(%)	95		95	
		Starting current	(A)	13.99 / 13.38 / 12.82			
COP		(Cooling/Heating)		3.42 / 4.24			
Operating noise	Indoor (Cooling/Heating)	Unit model	RAS-	M10PKVP-E	M13PKVP-E	M16PKVP-E	M18PKVP-E
		High	dB (A)	43 / 43	45 / 45	47 / 47	49 / 49
		Medium	dB (A)	37 / 35	38 / 36	40 / 38	41 / 41
		Low	dB (A)	31 / 27	31 / 27	34 / 30	34 / 31
	Outdoor (Cooling/Heating)	Unit model	RAS-	5M34UAV-E			
	Full indoor units operating		51 / 54				
Indoor unit	Unit model	RAS-	M10PKVP-E	M13PKVP-E	M16PKVP-E	M18PKVP-E	
	Dimension	Height	(mm)	295	295	295	295
		Width	(mm)	790	790	790	790
		Depth	(mm)	242	242	242	242
	Net weight	(kg)	12	12	12	12	
	Fan motor output	(W)	30	30	30	30	
Air flow rate	(Cooling/Heating)	(m <sup>3</sup> /h)	640 / 640	690 / 690	750 / 750	800 / 800	
Outdoor unit	Unit model	RAS-	5M34UAV-E				
	Dimension	Height	(mm)	890			
		Width	(mm)	900			
		Depth	(mm)	320			
	Net weight	(kg)	75				
	Compressor	Motor output	(W)	2200			
		Type		Twin rotary type with DC-inverter variable speed control			
		Model		DA270A2F-20L			
Fan motor output	(W)	100					
Air flow rate	(m <sup>3</sup> /h)	High: 3562, Medium: 2867					
Type		Flare connection					
Piping connection	Indoor unit	Unit model	RAS-	M10PKVP-E	M13PKVP-E	M16PKVP-E	M18PKVP-E
		Liquid side		Ø6.35	Ø6.35	Ø6.35	Ø6.35
		Gas side		Ø9.52	Ø9.52	Ø12.7	Ø12.7
	Outdoor unit	Unit model	RAS-	5M34UAV-E			
		A unit liquid side/gas side		Ø6.35 / Ø12.7			
		B unit liquid side/gas side		Ø6.35 / Ø12.7			
		C unit liquid side/gas side		Ø6.35 / Ø9.52			
		D unit liquid side/gas side		Ø6.35 / Ø9.52			
	E unit liquid side/gas side		Ø6.35 / Ø9.52				
	Maximum length (per unit)	(m)	25				
	Maximum length (total)	(m)	80				
	Maximum chargeless length	(m)	40				
	Maximum height difference	(m)	15				
Name of refrigerant		R410A					
Weight	(kg)	2.99					
Wiring connection	Power supply interconnection		3 Wires : includes earth, 4 Wires : includes earth				
Usable temperature range	Indoor (Cooling/Heating)	(°C)	21 - 32 / 0 - 28				
	Outdoor (Cooling/Heating)	(°C)	10 - 43 / -10 - 22				
Accessory	Indoor unit	Unit model	RAS-	M10PKVP-E	M13PKVP-E	M16PKVP-E	M18PKVP-E
		Installation plate		1	1	1	1
		Wireless remote controller		1	1	1	1
		Batteries		2	2	2	2
		Remote controller holder		1	1	1	1
		Remote controller holder mounting screw		2 (Ø3.1 × 16L)	2 (Ø3.1 × 16L)	2 (Ø3.1 × 16L)	2 (Ø3.1 × 16L)
		Owner's manual		1	1	1	1
		Mounting screw		7 (Ø4 × 25L)	7 (Ø4 × 25L)	7 (Ø4 × 25L)	7 (Ø4 × 25L)
	Installation manual		1	1	1	1	
	Outdoor unit	Unit model	RAS-	5M34UAV-E			
	Installation manual		1				

- For performance when each indoor unit is combined with other unit, refer to the separate table.
- The specifications may be subject to change without notice for purpose of improvement.

## 2-2. Specifications of Performance When Each Indoor Unit is Combined with Other Unit Outdoor Unit : RAS-5M34UAV-E

<Cooling/220V>

Power supply (V)	Operating status	Indoor unit					Unit Capacity					Total			Outdoor noise (dB)	
		A	B	C	D	E	A	B	C	D	E	Cooling capacity (kW)	Power consumption (W)	Operating current (A)		
220	1 unit	07	—	—	—	—	2.0	—	—	—	—	2.0	650 (1.4 - 2.5)	650 (640 - 700)	3.84 (3.83 - 3.74)	51
		10	—	—	—	—	2.7	—	—	—	—	2.7 (1.4 - 3.2)	750 (640 - 950)	4.43 (3.83 - 4.64)	51	
		13	—	—	—	—	3.7	—	—	—	—	3.7 (1.4 - 4.4)	1200 (640 - 1520)	6.20 (3.68 - 7.20)	51	
		16	—	—	—	—	4.5	—	—	—	—	4.5 (1.4 - 5.0)	1650 (640 - 2000)	7.98 (3.68 - 9.28)	51	
		18	—	—	—	—	5.0	—	—	—	—	5.0 (1.4 - 5.2)	1950 (640 - 2100)	9.33 (3.68 - 9.74)	51	
	2 units	07	07	—	—	—	2.00	2.00	—	—	—	4.0 (2.5 - 5.0)	1520 (640 - 1770)	7.27 (3.64 - 8.21)	51	
		10	07	—	—	—	2.70	2.00	—	—	—	4.7 (2.5 - 5.7)	1530 (640 - 1910)	7.32 (3.64 - 8.86)	51	
		13	07	—	—	—	3.70	2.00	—	—	—	5.7 (2.6 - 6.5)	1810 (660 - 2130)	8.66 (3.75 - 9.88)	51	
		16	07	—	—	—	4.08	1.82	—	—	—	5.9 (2.7 - 6.6)	1810 (660 - 2220)	8.66 (3.75 - 10.30)	51	
		18	07	—	—	—	4.50	1.80	—	—	—	6.3 (2.9 - 6.9)	2040 (670 - 2400)	9.76 (3.81 - 11.13)	51	
		10	10	—	—	—	2.70	2.70	—	—	—	5.4 (2.5 - 6.3)	1530 (640 - 2040)	7.32 (3.64 - 9.46)	51	
		13	10	—	—	—	3.41	2.49	—	—	—	5.9 (2.7 - 6.6)	1810 (660 - 2220)	8.66 (3.75 - 10.30)	51	
		16	10	—	—	—	3.94	2.36	—	—	—	6.3 (2.9 - 6.9)	2040 (670 - 2400)	9.76 (3.81 - 11.13)	51	
		18	10	—	—	—	4.09	2.21	—	—	—	6.3 (2.9 - 6.9)	2040 (670 - 2400)	9.76 (3.81 - 11.13)	51	
		13	13	—	—	—	3.15	3.15	—	—	—	6.3 (2.9 - 6.9)	2040 (670 - 2400)	9.76 (3.81 - 11.13)	51	
		16	13	—	—	—	3.73	3.07	—	—	—	6.8 (3.0 - 7.2)	2320 (690 - 2570)	11.10 (3.92 - 11.92)	51	
		18	13	—	—	—	3.91	2.89	—	—	—	6.8 (3.0 - 7.2)	2320 (690 - 2570)	11.10 (3.92 - 11.92)	51	
		16	16	—	—	—	3.60	3.60	—	—	—	7.2 (3.2 - 7.5)	2550 (700 - 2750)	12.20 (3.98 - 12.76)	51	
		18	16	—	—	—	3.79	3.41	—	—	—	7.2 (3.2 - 7.5)	2550 (700 - 2750)	12.20 (3.98 - 12.76)	51	
		18	18	—	—	—	3.60	3.60	—	—	—	7.2 (3.2 - 7.5)	2550 (700 - 2750)	12.20 (3.98 - 12.76)	51	
		3 units	07	07	07	—	—	2.00	2.00	2.00	—	—	6.0 (3.8 - 7.5)	2400 (950 - 2720)	11.48 (4.80 - 12.62)	51
			10	07	07	—	—	2.70	2.00	2.00	—	—	6.7 (3.8 - 8.2)	2400 (950 - 2720)	11.48 (4.80 - 12.62)	51
			13	07	07	—	—	3.65	1.97	1.97	—	—	7.6 (3.9 - 8.3)	2410 (960 - 2740)	11.53 (4.85 - 12.71)	51
	16		07	07	—	—	4.08	1.81	1.81	—	—	7.7 (4.0 - 8.5)	2410 (960 - 2790)	11.53 (4.85 - 12.94)	51	
	18		07	07	—	—	4.28	1.71	1.71	—	—	7.7 (4.0 - 8.5)	2410 (960 - 2790)	11.53 (4.85 - 12.94)	51	
	10		10	07	—	—	2.70	2.70	2.00	—	—	7.4 (3.8 - 8.2)	2400 (950 - 2720)	11.48 (4.80 - 12.62)	51	
	13		10	07	—	—	3.39	2.48	1.83	—	—	7.7 (3.9 - 8.3)	2410 (960 - 2740)	11.53 (4.85 - 12.71)	51	
	16		10	07	—	—	3.77	2.26	1.67	—	—	7.7 (4.0 - 8.5)	2410 (960 - 2790)	11.53 (4.85 - 12.94)	51	
	18		10	07	—	—	3.97	2.14	1.59	—	—	7.7 (4.0 - 8.5)	2410 (960 - 2790)	11.53 (4.85 - 12.94)	51	
	13		13	07	—	—	3.03	3.03	1.64	—	—	7.7 (4.0 - 8.5)	2410 (960 - 2790)	11.53 (4.85 - 12.94)	51	
	16		13	07	—	—	3.44	2.83	1.53	—	—	7.8 (4.1 - 8.6)	2430 (970 - 2810)	11.63 (4.90 - 13.03)	51	
	18		13	07	—	—	3.64	2.70	1.46	—	—	7.8 (4.1 - 8.6)	2430 (970 - 2810)	11.63 (4.90 - 13.03)	51	
	16		16	07	—	—	3.19	3.19	1.42	—	—	7.8 (4.1 - 8.6)	2430 (970 - 2810)	11.63 (4.90 - 13.03)	51	
	18		16	07	—	—	3.39	3.05	1.36	—	—	7.8 (4.1 - 8.6)	2430 (970 - 2810)	11.63 (4.90 - 13.03)	51	
	18		18	07	—	—	3.29	3.29	1.32	—	—	7.9 (4.1 - 8.7)	2440 (970 - 2830)	11.67 (4.90 - 13.13)	51	
	10		10	10	—	—	2.53	2.53	2.53	—	—	7.6 (3.8 - 8.2)	2400 (950 - 2720)	11.48 (4.80 - 12.62)	51	
	13		10	10	—	—	3.13	2.28	2.28	—	—	7.7 (3.9 - 8.3)	2410 (960 - 2740)	11.53 (4.85 - 12.71)	51	
	16		10	10	—	—	3.50	2.10	2.10	—	—	7.7 (4.0 - 8.5)	2410 (960 - 2790)	11.53 (4.85 - 12.94)	51	
	18		10	10	—	—	3.70	2.00	2.00	—	—	7.7 (4.0 - 8.5)	2410 (960 - 2790)	11.53 (4.85 - 12.94)	51	
	13		13	10	—	—	2.82	2.82	2.06	—	—	7.7 (4.0 - 8.5)	2410 (960 - 2790)	11.53 (4.85 - 12.94)	51	
	16		13	10	—	—	3.22	2.65	1.93	—	—	7.8 (4.1 - 8.6)	2430 (970 - 2810)	11.63 (4.90 - 13.03)	51	
	18		13	10	—	—	3.42	2.53	1.85	—	—	7.8 (4.1 - 8.6)	2430 (970 - 2810)	11.63 (4.90 - 13.03)	51	
	16		16	10	—	—	3.04	3.04	1.82	—	—	7.9 (4.1 - 8.7)	2440 (970 - 2830)	11.67 (4.90 - 13.13)	51	
	18		16	10	—	—	3.20	2.88	1.73	—	—	7.8 (4.1 - 8.6)	2430 (970 - 2810)	11.63 (4.90 - 13.03)	51	
	18		18	10	—	—	3.11	3.11	1.68	—	—	7.9 (4.1 - 8.7)	2440 (970 - 2830)	11.67 (4.90 - 13.13)	51	
13	13		13	—	—	2.60	2.60	2.60	—	—	7.8 (4.1 - 8.6)	2430 (970 - 2810)	11.63 (4.90 - 13.03)	51		
16	13		13	—	—	2.99	2.46	2.46	—	—	7.9 (4.1 - 8.7)	2440 (970 - 2830)	11.67 (4.90 - 13.13)	51		
18	13		13	—	—	3.19	2.36	2.36	—	—	7.9 (4.1 - 8.7)	2440 (970 - 2830)	11.67 (4.90 - 13.13)	51		
16	16		13	—	—	2.80	2.80	2.30	—	—	7.9 (4.1 - 8.7)	2440 (970 - 2830)	11.67 (4.90 - 13.13)	51		
18	16		13	—	—	2.99	2.69	2.21	—	—	7.9 (4.1 - 8.7)	2440 (970 - 2830)	11.67 (4.90 - 13.13)	51		
18	18	13	—	—	2.88	2.88	2.13	—	—	7.9 (4.1 - 8.7)	2440 (970 - 2830)	11.67 (4.90 - 13.13)	51			

• The above specification values are those under the conditions that the indoor DB/WB=27/19°C and the outdoor DB/WB=35/—°C.

<Cooling/220V> (Continued)

Power supply (V)	Operating status	Indoor unit					Unit Capacity					Total			Outdoor noise (dB)
		A	B	C	D	E	A	B	C	D	E	Cooling capacity (kW)	Power consumption (W)	Operating current (A)	
220	4 units	07	07	07	07	—	1.95	1.95	1.95	1.95	—	7.8 (4.0 - 8.7)	2450 (930 - 2800)	11.72 (4.70 - 12.99)	51
		10	07	07	07	—	2.42	1.79	1.79	1.79	—	7.8 (4.0 - 8.7)	2450 (930 - 2800)	11.72 (4.70 - 12.99)	51
		13	07	07	07	—	3.01	1.63	1.63	1.63	—	7.9 (4.1 - 8.8)	2450 (940 - 2820)	11.72 (4.75 - 13.08)	51
		16	07	07	07	—	3.39	1.50	1.50	1.50	—	7.9 (4.1 - 9.0)	2500 (940 - 2860)	11.96 (4.75 - 13.27)	51
		18	07	07	07	—	3.59	1.44	1.44	1.44	—	7.9 (4.1 - 9.0)	2500 (940 - 2860)	11.96 (4.75 - 13.27)	51
		10	10	07	07	—	2.24	2.24	1.66	1.66	—	7.8 (4.0 - 8.7)	2450 (930 - 2800)	11.72 (4.70 - 12.99)	51
		13	10	07	07	—	2.81	2.05	1.52	1.52	—	7.9 (4.1 - 8.8)	2450 (940 - 2820)	11.72 (4.75 - 13.08)	51
		16	10	07	07	—	3.17	1.90	1.41	1.41	—	7.9 (4.1 - 9.0)	2500 (940 - 2860)	11.96 (4.75 - 13.27)	51
		18	10	07	07	—	3.38	1.82	1.35	1.35	—	7.9 (4.1 - 9.0)	2500 (940 - 2860)	11.96 (4.75 - 13.27)	51
		13	13	07	07	—	2.56	2.56	1.39	1.39	—	7.9 (4.1 - 9.0)	2500 (940 - 2860)	11.96 (4.75 - 13.27)	51
		16	13	07	07	—	2.95	2.43	1.31	1.31	—	8.0 (4.2 - 9.1)	2500 (950 - 2880)	11.96 (4.80 - 13.36)	51
		18	13	07	07	—	3.15	2.33	1.26	1.26	—	8.0 (4.2 - 9.1)	2500 (950 - 2880)	11.96 (4.80 - 13.36)	51
		16	16	07	07	—	2.77	2.77	1.23	1.23	—	8.0 (4.2 - 9.2)	2500 (950 - 2900)	11.96 (4.80 - 13.45)	51
		18	16	07	07	—	2.96	2.67	1.19	1.19	—	8.0 (4.2 - 9.2)	2500 (950 - 2900)	11.96 (4.80 - 13.45)	51
		18	18	07	07	—	2.86	2.86	1.14	1.14	—	8.0 (4.2 - 9.2)	2500 (950 - 2900)	11.96 (4.80 - 13.45)	51
		10	10	10	07	—	2.11	2.11	2.11	1.56	—	7.9 (4.0 - 8.7)	2450 (930 - 2800)	11.72 (4.70 - 12.99)	51
		13	10	10	07	—	2.63	1.92	1.92	1.42	—	7.9 (4.1 - 8.8)	2450 (940 - 2820)	11.72 (4.75 - 13.08)	51
		16	10	10	07	—	2.99	1.79	1.79	1.33	—	7.9 (4.1 - 9.0)	2500 (940 - 2860)	11.96 (4.75 - 13.27)	51
		18	10	10	07	—	3.23	1.74	1.74	1.29	—	8.0 (4.1 - 9.0)	2500 (940 - 2860)	11.96 (4.75 - 13.27)	51
		13	13	10	07	—	2.45	2.45	1.79	1.32	—	8.0 (4.1 - 9.0)	2500 (940 - 2860)	11.96 (4.75 - 13.27)	51
		16	13	10	07	—	2.79	2.29	1.67	1.24	—	8.0 (4.2 - 9.1)	2500 (950 - 2880)	11.96 (4.80 - 13.36)	51
		18	13	10	07	—	2.99	2.21	1.61	1.19	—	8.0 (4.2 - 9.1)	2500 (950 - 2880)	11.96 (4.80 - 13.36)	51
		16	16	10	07	—	2.63	2.63	1.58	1.17	—	8.0 (4.2 - 9.2)	2500 (950 - 2900)	11.96 (4.80 - 13.45)	51
		18	16	10	07	—	2.82	2.54	1.52	1.13	—	8.0 (4.2 - 9.2)	2500 (950 - 2900)	11.96 (4.80 - 13.45)	51
		18	18	10	07	—	2.72	2.72	1.47	1.09	—	8.0 (4.2 - 9.2)	2500 (950 - 2900)	11.96 (4.80 - 13.45)	51
		13	13	13	07	—	2.26	2.26	2.26	1.22	—	8.0 (4.2 - 9.1)	2500 (950 - 2880)	11.96 (4.80 - 13.36)	51
		16	13	13	07	—	2.59	2.13	2.13	1.15	—	8.0 (4.2 - 9.2)	2500 (950 - 2900)	11.96 (4.80 - 13.45)	51
		18	13	13	07	—	2.78	2.06	2.06	1.11	—	8.0 (4.2 - 9.2)	2500 (950 - 2900)	11.96 (4.80 - 13.45)	51
		16	16	13	07	—	2.45	2.45	2.01	1.09	—	8.0 (4.2 - 9.2)	2500 (950 - 2900)	11.96 (4.80 - 13.45)	51
		18	16	13	07	—	2.63	2.37	1.95	1.05	—	8.0 (4.2 - 9.2)	2500 (950 - 2900)	11.96 (4.80 - 13.45)	51
		18	18	13	07	—	2.55	2.55	1.89	1.02	—	8.0 (4.2 - 9.2)	2500 (950 - 2900)	11.96 (4.80 - 13.45)	51
		10	10	10	10	—	1.98	1.98	1.98	1.98	—	7.9 (4.0 - 8.7)	2450 (930 - 2800)	11.72 (4.70 - 12.99)	51
		13	10	10	10	—	2.48	1.81	1.81	1.81	—	7.9 (4.1 - 8.8)	2450 (940 - 2820)	11.72 (4.75 - 13.08)	51
		16	10	10	10	—	2.86	1.71	1.71	1.71	—	8.0 (4.1 - 9.0)	2500 (940 - 2860)	11.96 (4.75 - 13.27)	51
		18	10	10	10	—	3.05	1.65	1.65	1.65	—	8.0 (4.1 - 9.0)	2500 (940 - 2860)	11.96 (4.75 - 13.27)	51
		13	13	10	10	—	2.31	2.31	1.69	1.69	—	8.0 (4.1 - 9.0)	2500 (940 - 2860)	11.96 (4.75 - 13.27)	51
		16	13	10	10	—	2.65	2.18	1.59	1.59	—	8.0 (4.2 - 9.1)	2500 (950 - 2880)	11.96 (4.80 - 13.36)	51
		16	16	10	10	—	2.50	2.50	1.50	1.50	—	8.0 (4.2 - 9.2)	2500 (950 - 2900)	11.96 (4.80 - 13.45)	51
		18	13	10	10	—	2.84	2.10	1.53	1.53	—	8.0 (4.2 - 9.1)	2500 (950 - 2880)	11.96 (4.80 - 13.36)	51
		18	16	10	10	—	2.68	2.42	1.45	1.45	—	8.0 (4.2 - 9.2)	2500 (950 - 2900)	11.96 (4.80 - 13.45)	51
		18	18	10	10	—	2.60	2.60	1.40	1.40	—	8.0 (4.2 - 9.2)	2500 (950 - 2900)	11.96 (4.80 - 13.45)	51
		13	13	13	10	—	2.14	2.14	2.14	1.57	—	8.0 (4.2 - 9.1)	2500 (950 - 2880)	11.96 (4.80 - 13.36)	51
		16	13	13	10	—	2.47	2.03	2.03	1.48	—	8.0 (4.2 - 9.2)	2500 (950 - 2900)	11.96 (4.80 - 13.45)	51
		16	16	13	10	—	2.34	2.34	1.92	1.40	—	8.0 (4.2 - 9.1)	2500 (950 - 2880)	11.96 (4.80 - 13.36)	51
		18	13	13	10	—	2.65	1.96	1.96	1.43	—	8.0 (4.2 - 9.2)	2500 (950 - 2900)	11.96 (4.80 - 13.45)	51
		18	16	13	10	—	2.52	2.26	1.86	1.36	—	8.0 (4.2 - 9.2)	2500 (950 - 2900)	11.96 (4.80 - 13.45)	51
		18	18	13	10	—	2.44	2.44	1.80	1.32	—	8.0 (4.2 - 9.2)	2500 (950 - 2900)	11.96 (4.80 - 13.45)	51
		13	13	13	13	—	2.00	2.00	2.00	2.00	—	8.0 (4.2 - 9.2)	2500 (950 - 2900)	11.96 (4.80 - 13.45)	51
16	13	13	13	—	2.31	1.90	1.90	1.90	—	8.0 (4.2 - 9.2)	2500 (950 - 2900)	11.96 (4.80 - 13.45)	51		
18	13	13	13	—	2.48	1.84	1.84	1.84	—	8.0 (4.2 - 9.2)	2500 (950 - 2900)	11.96 (4.80 - 13.45)	51		
16	16	13	13	—	2.20	2.20	1.80	1.80	—	8.0 (4.2 - 9.2)	2500 (950 - 2900)	11.96 (4.80 - 13.45)	51		
18	16	13	13	—	2.37	2.13	1.75	1.75	—	8.0 (4.2 - 9.2)	2500 (950 - 2900)	11.96 (4.80 - 13.45)	51		
18	18	13	13	—	2.30	2.30	1.70	1.70	—	8.0 (4.2 - 9.2)	2500 (950 - 2900)	11.96 (4.80 - 13.45)	51		

• The above specification values are those under the conditions that the indoor DB/WB=27/19°C and the outdoor DB/WB=35/—°C.

<Cooling/220V> (Continued)

Power supply (V)	Operating status	Indoor unit					Unit Capacity					Total			Outdoor noise (dB)
		A	B	C	D	E	A	B	C	D	E	Cooling capacity (kW)	Power consumption (W)	Operating current (A)	
220	5 units	07	07	07	07	07	1.96	1.96	1.96	1.96	1.96	9.8 (3.7 - 10.8)	2865 (950 - 3630)	13.71 (4.80 - 16.84)	51
		10	07	07	07	07	2.50	1.85	1.85	1.85	1.85	9.9 (3.7 - 10.9)	2894 (950 - 3670)	13.85 (4.80 - 17.02)	51
		13	07	07	07	07	3.13	1.69	1.69	1.69	1.69	9.9 (3.7 - 10.9)	2894 (950 - 3670)	13.85 (4.80 - 17.02)	51
		16	07	07	07	07	3.56	1.58	1.58	1.58	1.58	9.9 (3.7 - 10.9)	2894 (950 - 3670)	13.85 (4.80 - 17.02)	51
		18	07	07	07	07	3.81	1.52	1.52	1.52	1.52	9.9 (3.7 - 10.9)	2894 (950 - 3670)	13.85 (4.80 - 17.02)	51
		10	10	07	07	07	2.34	2.34	1.74	1.74	1.74	9.9 (3.7 - 10.9)	2894 (950 - 3670)	13.85 (4.80 - 17.02)	51
		13	10	07	07	07	2.95	2.16	1.60	1.60	1.60	9.9 (3.7 - 10.9)	2894 (950 - 3670)	13.85 (4.80 - 17.02)	51
		16	10	07	07	07	3.38	2.03	1.50	1.50	1.50	9.9 (3.7 - 10.9)	2894 (950 - 3670)	13.85 (4.80 - 17.02)	51
		18	10	07	07	07	3.61	1.95	1.45	1.45	1.45	9.9 (3.7 - 10.9)	2894 (950 - 3670)	13.85 (4.80 - 17.02)	51
		13	13	07	07	07	2.73	2.73	1.48	1.48	1.48	9.9 (3.7 - 10.9)	2894 (950 - 3670)	13.85 (4.80 - 17.02)	51
		16	13	07	07	07	3.14	2.58	1.39	1.39	1.39	9.9 (3.7 - 10.9)	2894 (950 - 3670)	13.85 (4.80 - 17.02)	51
		18	13	07	07	07	3.37	2.49	1.35	1.35	1.35	9.9 (3.7 - 10.9)	2894 (950 - 3670)	13.85 (4.80 - 17.02)	51
		16	16	07	07	07	2.97	2.97	1.32	1.32	1.32	9.9 (3.7 - 10.9)	2894 (950 - 3670)	13.85 (4.80 - 17.02)	51
		18	16	07	07	07	3.19	2.87	1.28	1.28	1.28	9.9 (3.7 - 10.9)	2894 (950 - 3670)	13.85 (4.80 - 17.02)	51
		10	10	10	07	07	2.21	2.21	2.21	1.64	1.64	9.9 (3.7 - 10.9)	2894 (950 - 3670)	13.85 (4.80 - 17.02)	51
		13	10	10	07	07	2.80	2.04	2.04	1.51	1.51	9.9 (3.7 - 10.9)	2894 (950 - 3670)	13.85 (4.80 - 17.02)	51
		13	13	10	07	07	2.60	2.60	1.90	1.40	1.40	9.9 (3.7 - 10.9)	2894 (950 - 3670)	13.85 (4.80 - 17.02)	51
		16	10	10	07	07	3.21	1.92	1.92	1.42	1.42	9.9 (3.7 - 10.9)	2894 (950 - 3670)	13.85 (4.80 - 17.02)	51
		18	10	10	07	07	3.44	1.86	1.86	1.38	1.38	9.9 (3.7 - 10.9)	2894 (950 - 3670)	13.85 (4.80 - 17.02)	51
		13	13	13	07	07	2.43	2.43	2.43	1.31	1.31	9.9 (3.7 - 10.9)	2894 (950 - 3670)	13.85 (4.80 - 17.02)	51
		16	13	13	07	07	2.80	2.30	2.30	1.25	1.25	9.9 (3.7 - 10.9)	2894 (950 - 3670)	13.85 (4.80 - 17.02)	51
		18	13	13	07	07	3.02	2.23	2.23	1.21	1.21	9.9 (3.7 - 10.9)	2894 (950 - 3670)	13.85 (4.80 - 17.02)	51
		16	16	10	07	07	2.84	2.84	1.70	1.26	1.26	9.9 (3.7 - 10.9)	2894 (950 - 3670)	13.85 (4.80 - 17.02)	51
		18	16	10	07	07	3.06	2.75	1.65	1.22	1.22	9.9 (3.7 - 10.9)	2894 (950 - 3670)	13.85 (4.80 - 17.02)	51
		16	16	13	07	07	2.67	2.67	2.19	1.19	1.19	9.9 (3.7 - 10.9)	2894 (950 - 3670)	13.85 (4.80 - 17.02)	51
		18	16	13	07	07	2.88	2.59	2.13	1.15	1.15	9.9 (3.7 - 10.9)	2894 (950 - 3670)	13.85 (4.80 - 17.02)	51
		10	10	10	10	07	2.09	2.09	2.09	2.09	2.09	9.9 (3.7 - 10.9)	2894 (950 - 3670)	13.85 (4.80 - 17.02)	51
		13	10	10	10	07	2.65	1.94	1.94	1.94	1.94	9.9 (3.7 - 10.9)	2894 (950 - 3670)	13.85 (4.80 - 17.02)	51
		16	10	10	10	07	3.05	1.83	1.83	1.83	1.83	9.9 (3.7 - 10.9)	2894 (950 - 3670)	13.85 (4.80 - 17.02)	51
		13	13	10	10	07	2.48	2.48	1.81	1.81	1.81	9.9 (3.7 - 10.9)	2894 (950 - 3670)	13.85 (4.80 - 17.02)	51
		16	13	10	10	07	2.86	2.35	1.71	1.71	1.71	9.9 (3.7 - 10.9)	2894 (950 - 3670)	13.85 (4.80 - 17.02)	51
		16	16	10	10	07	2.72	2.72	1.63	1.63	1.63	9.9 (3.7 - 10.9)	2894 (950 - 3670)	13.85 (4.80 - 17.02)	51
		13	13	13	10	07	2.32	2.32	2.32	1.69	1.69	9.9 (3.7 - 10.9)	2894 (950 - 3670)	13.85 (4.80 - 17.02)	51
		16	13	13	10	07	2.68	2.21	2.21	1.61	1.61	9.9 (3.7 - 10.9)	2894 (950 - 3670)	13.85 (4.80 - 17.02)	51
		16	16	13	10	07	2.56	2.56	2.11	1.54	1.54	9.9 (3.7 - 10.9)	2894 (950 - 3670)	13.85 (4.80 - 17.02)	51
		13	13	13	13	07	2.18	2.18	2.18	2.18	2.18	9.9 (3.7 - 10.9)	2894 (950 - 3670)	13.85 (4.80 - 17.02)	51
		16	13	13	13	07	2.53	2.08	2.08	2.08	2.08	9.9 (3.7 - 10.9)	2894 (950 - 3670)	13.85 (4.80 - 17.02)	51
		16	16	13	13	07	2.42	2.42	1.99	1.99	1.99	9.9 (3.7 - 10.9)	2894 (950 - 3670)	13.85 (4.80 - 17.02)	51
		10	10	10	10	10	1.98	1.98	1.98	1.98	1.98	9.9 (3.7 - 10.9)	2894 (950 - 3670)	13.85 (4.80 - 17.02)	51
		13	10	10	10	10	2.53	1.84	1.84	1.84	1.84	9.9 (3.7 - 10.9)	2894 (950 - 3670)	13.85 (4.80 - 17.02)	51
16	10	10	10	10	2.91	1.75	1.75	1.75	1.75	9.9 (3.7 - 10.9)	2894 (950 - 3670)	13.85 (4.80 - 17.02)	51		
18	10	10	10	10	3.13	1.69	1.69	1.69	1.69	9.9 (3.7 - 10.9)	2894 (950 - 3670)	13.85 (4.80 - 17.02)	51		
13	13	10	10	10	2.36	2.36	1.72	1.72	1.72	9.9 (3.7 - 10.9)	2894 (950 - 3670)	13.85 (4.80 - 17.02)	51		
16	13	10	10	10	2.73	2.25	1.64	1.64	1.64	9.9 (3.7 - 10.9)	2894 (950 - 3670)	13.85 (4.80 - 17.02)	51		
18	13	10	10	10	2.95	2.18	1.59	1.59	1.59	9.9 (3.7 - 10.9)	2894 (950 - 3670)	13.85 (4.80 - 17.02)	51		
16	16	10	10	10	2.61	2.61	1.56	1.56	1.56	9.9 (3.7 - 10.9)	2894 (950 - 3670)	13.85 (4.80 - 17.02)	51		
13	13	13	10	10	2.22	2.22	2.22	1.62	1.62	9.9 (3.7 - 10.9)	2894 (950 - 3670)	13.85 (4.80 - 17.02)	51		
16	13	13	10	10	2.58	2.12	2.12	1.55	1.55	9.9 (3.7 - 10.9)	2894 (950 - 3670)	13.85 (4.80 - 17.02)	51		
18	13	13	10	10	2.78	2.06	2.06	1.50	1.50	9.9 (3.7 - 10.9)	2894 (950 - 3670)	13.85 (4.80 - 17.02)	51		
16	16	13	10	10	2.49	2.49	2.04	1.49	1.49	10.0 (3.7 - 11.0)	2923 (950 - 3700)	13.99 (4.80 - 17.16)	51		
13	13	13	13	10	2.09	2.09	2.09	2.09	2.09	9.9 (3.7 - 10.9)	2894 (950 - 3670)	13.85 (4.80 - 17.02)	51		
16	13	13	13	10	2.46	2.02	2.02	2.02	2.02	10.0 (3.7 - 11.0)	2923 (950 - 3700)	13.99 (4.80 - 17.16)	51		
18	13	13	13	10	2.66	1.97	1.97	1.97	1.97	10.0 (3.7 - 11.0)	2923 (950 - 3700)	13.99 (4.80 - 17.16)	51		
16	16	13	13	10	2.36	2.36	1.94	1.94	1.94	10.0 (3.7 - 11.0)	2923 (950 - 3700)	13.99 (4.80 - 17.16)	51		
13	13	13	13	13	2.00	2.00	2.00	2.00	2.00	10.0 (3.7 - 11.0)	2923 (950 - 3700)	13.99 (4.80 - 17.16)	51		
16	13	13	13	13	2.33	1.92	1.92	1.92	1.92	10.0 (3.7 - 11.0)	2923 (950 - 3700)	13.99 (4.80 - 17.16)	51		

• The above specification values are those under the conditions that the indoor DB/WB=27/19°C and the outdoor DB/WB=35/—°C.

Outdoor Unit : RAS-5M34UAV-E

<Cooling/230V>

Power supply (V)	Operating status	Indoor unit					Unit Capacity					Total			Outdoor noise (dB)
		A	B	C	D	E	A	B	C	D	E	Cooling capacity (kW)	Power consumption (W)	Operating current (A)	
230	1 unit	07	—	—	—	—	2.0	—	—	—	—	2.0 (1.4 - 2.5)	650 (640 - 700)	3.67 (3.66 - 3.58)	51
		10	—	—	—	—	2.7	—	—	—	—	2.7 (1.4 - 3.2)	750 (640 - 950)	4.23 (3.66 - 4.44)	51
		13	—	—	—	—	3.7	—	—	—	—	3.7 (1.4 - 4.4)	1200 (640 - 1520)	5.93 (3.52 - 6.88)	51
		16	—	—	—	—	4.5	—	—	—	—	4.5 (1.4 - 5.0)	1650 (640 - 2000)	7.63 (3.52 - 8.87)	51
		18	—	—	—	—	5.0	—	—	—	—	5.0 (1.4 - 5.2)	1950 (640 - 2100)	8.92 (3.52 - 9.32)	51
	2 units	07	07	—	—	—	2.00	2.00	—	—	—	4.0 (2.5 - 5.0)	1520 (640 - 1770)	6.96 (3.48 - 7.85)	51
		10	07	—	—	—	2.70	2.00	—	—	—	4.7 (2.5 - 5.7)	1530 (640 - 1910)	7.00 (3.48 - 8.47)	51
		13	07	—	—	—	3.70	2.00	—	—	—	5.7 (2.6 - 6.5)	1810 (660 - 2130)	8.28 (3.59 - 9.45)	51
		16	07	—	—	—	4.08	1.82	—	—	—	5.9 (2.7 - 6.6)	1810 (660 - 2220)	8.28 (3.59 - 9.85)	51
		18	07	—	—	—	4.50	1.80	—	—	—	6.3 (2.9 - 6.9)	2040 (670 - 2400)	9.34 (3.64 - 10.65)	51
		10	10	—	—	—	2.70	2.70	—	—	—	5.4 (2.5 - 6.3)	1530 (640 - 2040)	7.00 (3.48 - 9.05)	51
		13	10	—	—	—	3.41	2.49	—	—	—	5.9 (2.7 - 6.6)	1810 (660 - 2220)	8.28 (3.59 - 9.85)	51
		16	10	—	—	—	3.94	2.36	—	—	—	6.3 (2.9 - 6.9)	2040 (670 - 2400)	9.34 (3.64 - 10.65)	51
		18	10	—	—	—	4.09	2.21	—	—	—	6.3 (2.9 - 6.9)	2040 (670 - 2400)	9.34 (3.64 - 10.65)	51
		13	13	—	—	—	3.15	3.15	—	—	—	6.3 (2.9 - 6.9)	2040 (670 - 2400)	9.34 (3.64 - 10.65)	51
		16	13	—	—	—	3.73	3.07	—	—	—	6.8 (3.0 - 7.2)	2320 (690 - 2570)	10.62 (3.75 - 11.40)	51
		18	13	—	—	—	3.91	2.89	—	—	—	6.8 (3.0 - 7.2)	2320 (690 - 2570)	10.62 (3.75 - 11.40)	51
		16	16	—	—	—	3.60	3.60	—	—	—	7.2 (3.2 - 7.5)	2550 (700 - 2750)	11.67 (3.80 - 12.20)	51
		18	16	—	—	—	3.79	3.41	—	—	—	7.2 (3.2 - 7.5)	2550 (700 - 2750)	11.67 (3.80 - 12.20)	51
		18	18	—	—	—	3.60	3.60	—	—	—	7.2 (3.2 - 7.5)	2550 (700 - 2750)	11.67 (3.80 - 12.20)	51
	3 units	07	07	07	—	—	2.00	2.00	2.00	—	—	6.0 (3.8 - 7.5)	2400 (950 - 2720)	10.98 (4.59 - 12.07)	51
		10	07	07	—	—	2.70	2.00	2.00	—	—	6.7 (3.8 - 8.2)	2400 (950 - 2720)	10.98 (4.59 - 12.07)	51
		13	07	07	—	—	3.65	1.97	1.97	—	—	7.6 (3.9 - 8.3)	2410 (960 - 2740)	11.03 (4.64 - 12.16)	51
		16	07	07	—	—	4.08	1.81	1.81	—	—	7.7 (4.0 - 8.5)	2410 (960 - 2790)	11.03 (4.64 - 12.38)	51
		18	07	07	—	—	4.28	1.71	1.71	—	—	7.7 (4.0 - 8.5)	2410 (960 - 2790)	11.03 (4.64 - 12.38)	51
		10	10	07	—	—	2.70	2.70	2.00	—	—	7.4 (3.8 - 8.2)	2400 (950 - 2720)	10.98 (4.59 - 12.07)	51
		13	10	07	—	—	3.39	2.48	1.83	—	—	7.7 (3.9 - 8.3)	2410 (960 - 2740)	11.03 (4.64 - 12.16)	51
		16	10	07	—	—	3.77	2.26	1.67	—	—	7.7 (4.0 - 8.5)	2410 (960 - 2790)	11.03 (4.64 - 12.38)	51
		18	10	07	—	—	3.97	2.14	1.59	—	—	7.7 (4.0 - 8.5)	2410 (960 - 2790)	11.03 (4.64 - 12.38)	51
		13	13	07	—	—	3.03	3.03	1.64	—	—	7.7 (4.0 - 8.5)	2410 (960 - 2790)	11.03 (4.64 - 12.38)	51
		16	13	07	—	—	3.44	2.83	1.53	—	—	7.8 (4.1 - 8.6)	2430 (970 - 2810)	11.12 (4.69 - 12.47)	51
		18	13	07	—	—	3.64	2.70	1.46	—	—	7.8 (4.1 - 8.6)	2430 (970 - 2810)	11.12 (4.69 - 12.47)	51
		16	16	07	—	—	3.19	3.19	1.42	—	—	7.8 (4.1 - 8.6)	2430 (970 - 2810)	11.12 (4.69 - 12.47)	51
		18	16	07	—	—	3.39	3.05	1.36	—	—	7.8 (4.1 - 8.6)	2430 (970 - 2810)	11.12 (4.69 - 12.47)	51
		18	18	07	—	—	3.29	3.29	1.32	—	—	7.9 (4.1 - 8.7)	2440 (970 - 2830)	11.17 (4.69 - 12.56)	51
		10	10	10	—	—	2.53	2.53	2.53	—	—	7.6 (3.8 - 8.2)	2400 (950 - 2720)	10.98 (4.59 - 12.07)	51
		13	10	10	—	—	3.13	2.28	2.28	—	—	7.7 (3.9 - 8.3)	2410 (960 - 2740)	11.03 (4.64 - 12.16)	51
		16	10	10	—	—	3.50	2.10	2.10	—	—	7.7 (4.0 - 8.5)	2410 (960 - 2790)	11.03 (4.64 - 12.38)	51
		18	10	10	—	—	3.70	2.00	2.00	—	—	7.7 (4.0 - 8.5)	2410 (960 - 2790)	11.03 (4.64 - 12.38)	51
		13	13	10	—	—	2.82	2.82	2.06	—	—	7.7 (4.0 - 8.5)	2410 (960 - 2790)	11.03 (4.64 - 12.38)	51
		16	13	10	—	—	3.22	2.65	1.93	—	—	7.8 (4.1 - 8.6)	2430 (970 - 2810)	11.12 (4.69 - 12.47)	51
		18	13	10	—	—	3.42	2.53	1.85	—	—	7.8 (4.1 - 8.6)	2430 (970 - 2810)	11.12 (4.69 - 12.47)	51
		16	16	10	—	—	3.04	3.04	1.82	—	—	7.9 (4.1 - 8.7)	2440 (970 - 2830)	11.17 (4.69 - 12.56)	51
		18	16	10	—	—	3.20	2.88	1.73	—	—	7.8 (4.1 - 8.6)	2430 (970 - 2810)	11.12 (4.69 - 12.47)	51
		18	18	10	—	—	3.11	3.11	1.68	—	—	7.9 (4.1 - 8.7)	2440 (970 - 2830)	11.17 (4.69 - 12.56)	51
13		13	13	—	—	2.60	2.60	2.60	—	—	7.8 (4.1 - 8.6)	2430 (970 - 2810)	11.12 (4.69 - 12.47)	51	
16		13	13	—	—	2.99	2.46	2.46	—	—	7.9 (4.1 - 8.7)	2440 (970 - 2830)	11.17 (4.69 - 12.56)	51	
18		13	13	—	—	3.19	2.36	2.36	—	—	7.9 (4.1 - 8.7)	2440 (970 - 2830)	11.17 (4.69 - 12.56)	51	
16		16	13	—	—	2.80	2.80	2.30	—	—	7.9 (4.1 - 8.7)	2440 (970 - 2830)	11.17 (4.69 - 12.56)	51	
18		16	13	—	—	2.99	2.69	2.21	—	—	7.9 (4.1 - 8.7)	2440 (970 - 2830)	11.17 (4.69 - 12.56)	51	
18	18	13	—	—	2.88	2.88	2.13	—	—	7.9 (4.1 - 8.7)	2440 (970 - 2830)	11.17 (4.69 - 12.56)	51		

• The above specification values are those under the conditions that the indoor DB/WB=27/19°C and the outdoor DB/WB=35/—°C.

<Cooling/230V> (Continued)

Power supply (V)	Operating status	Indoor unit					Unit Capacity					Total			Outdoor noise (dB)
		A	B	C	D	E	A	B	C	D	E	Cooling capacity (kW)	Power consumption (W)	Operating current (A)	
230	4 units	07	07	07	07	—	1.95	1.95	1.95	1.95	—	7.8 (4.0-8.7)	2450 (930-2800)	11.21 (4.49-12.42)	51
		10	07	07	07	—	2.42	1.79	1.79	1.79	—	7.8 (4.0-8.7)	2450 (930-2800)	11.21 (4.49-12.42)	51
		13	07	07	07	—	3.01	1.63	1.63	1.63	—	7.9 (4.1-8.8)	2450 (940-2820)	11.21 (4.54-12.51)	51
		16	07	07	07	—	3.39	1.50	1.50	1.50	—	7.9 (4.1-9.0)	2500 (940-2860)	11.44 (4.54-12.69)	51
		18	07	07	07	—	3.59	1.44	1.44	1.44	—	7.9 (4.1-9.0)	2500 (940-2860)	11.44 (4.54-12.69)	51
		10	10	07	07	—	2.24	2.24	1.66	1.66	—	7.8 (4.0-8.7)	2450 (930-2800)	11.21 (4.49-12.42)	51
		13	10	07	07	—	2.81	2.05	1.52	1.52	—	7.9 (4.1-8.8)	2450 (940-2820)	11.21 (4.54-12.51)	51
		16	10	07	07	—	3.17	1.90	1.41	1.41	—	7.9 (4.1-9.0)	2500 (940-2860)	11.44 (4.54-12.69)	51
		18	10	07	07	—	3.38	1.82	1.35	1.35	—	7.9 (4.1-9.0)	2500 (940-2860)	11.44 (4.54-12.69)	51
		13	13	07	07	—	2.56	2.56	1.39	1.39	—	7.9 (4.1-9.0)	2500 (940-2860)	11.44 (4.54-12.69)	51
		16	13	07	07	—	2.95	2.43	1.31	1.31	—	8.0 (4.2-9.1)	2500 (950-2880)	11.44 (4.59-12.78)	51
		18	13	07	07	—	3.15	2.33	1.26	1.26	—	8.0 (4.2-9.1)	2500 (950-2880)	11.44 (4.59-12.78)	51
		16	16	07	07	—	2.77	2.77	1.23	1.23	—	8.0 (4.2-9.2)	2500 (950-2900)	11.44 (4.59-12.87)	51
		18	16	07	07	—	2.96	2.67	1.19	1.19	—	8.0 (4.2-9.2)	2500 (950-2900)	11.44 (4.59-12.87)	51
		18	18	07	07	—	2.86	2.86	1.14	1.14	—	8.0 (4.2-9.2)	2500 (950-2900)	11.44 (4.59-12.87)	51
		10	10	10	07	—	2.11	2.11	2.11	1.56	—	7.9 (4.0-8.7)	2450 (930-2800)	11.21 (4.49-12.42)	51
		13	10	10	07	—	2.63	1.92	1.92	1.42	—	7.9 (4.1-8.8)	2450 (940-2820)	11.21 (4.54-12.51)	51
		16	10	10	07	—	2.99	1.79	1.79	1.33	—	7.9 (4.1-9.0)	2500 (940-2860)	11.44 (4.54-12.69)	51
		18	10	10	07	—	3.23	1.74	1.74	1.29	—	8.0 (4.1-9.0)	2500 (940-2860)	11.44 (4.54-12.69)	51
		13	13	10	07	—	2.45	2.45	1.79	1.32	—	8.0 (4.1-9.0)	2500 (940-2860)	11.44 (4.54-12.69)	51
		16	13	10	07	—	2.79	2.29	1.67	1.24	—	8.0 (4.2-9.1)	2500 (950-2880)	11.44 (4.59-12.78)	51
		18	13	10	07	—	2.99	2.21	1.61	1.19	—	8.0 (4.2-9.1)	2500 (950-2880)	11.44 (4.59-12.78)	51
		16	16	10	07	—	2.63	2.63	1.58	1.17	—	8.0 (4.2-9.2)	2500 (950-2900)	11.44 (4.59-12.87)	51
		18	16	10	07	—	2.82	2.54	1.52	1.13	—	8.0 (4.2-9.2)	2500 (950-2900)	11.44 (4.59-12.87)	51
		18	18	10	07	—	2.72	2.72	1.47	1.09	—	8.0 (4.2-9.2)	2500 (950-2900)	11.44 (4.59-12.87)	51
		13	13	13	07	—	2.26	2.26	2.26	1.22	—	8.0 (4.2-9.1)	2500 (950-2880)	11.44 (4.59-12.78)	51
		16	13	13	07	—	2.59	2.13	2.13	1.15	—	8.0 (4.2-9.2)	2500 (950-2900)	11.44 (4.59-12.87)	51
		18	13	13	07	—	2.78	2.06	2.06	1.11	—	8.0 (4.2-9.2)	2500 (950-2900)	11.44 (4.59-12.87)	51
		16	16	13	07	—	2.45	2.45	2.01	1.09	—	8.0 (4.2-9.2)	2500 (950-2900)	11.44 (4.59-12.87)	51
		18	16	13	07	—	2.63	2.37	1.95	1.05	—	8.0 (4.2-9.2)	2500 (950-2900)	11.44 (4.59-12.87)	51
		18	18	13	07	—	2.55	2.55	1.89	1.02	—	8.0 (4.2-9.2)	2500 (950-2900)	11.44 (4.59-12.87)	51
		10	10	10	10	—	1.98	1.98	1.98	1.98	—	7.9 (4.0-8.7)	2450 (930-2800)	11.21 (4.49-12.42)	51
		13	10	10	10	—	2.48	1.81	1.81	1.81	—	7.9 (4.1-8.8)	2450 (940-2820)	11.21 (4.54-12.51)	51
		16	10	10	10	—	2.86	1.71	1.71	1.71	—	8.0 (4.1-9.0)	2500 (940-2860)	11.44 (4.54-12.69)	51
		18	10	10	10	—	3.05	1.65	1.65	1.65	—	8.0 (4.1-9.0)	2500 (940-2860)	11.44 (4.54-12.69)	51
		13	13	10	10	—	2.31	2.31	1.69	1.69	—	8.0 (4.1-9.0)	2500 (940-2860)	11.44 (4.54-12.69)	51
		16	13	10	10	—	2.65	2.18	1.59	1.59	—	8.0 (4.2-9.1)	2500 (950-2880)	11.44 (4.59-12.78)	51
		16	16	10	10	—	2.50	2.50	1.50	1.50	—	8.0 (4.2-9.2)	2500 (950-2900)	11.44 (4.59-12.87)	51
		18	13	10	10	—	2.84	2.10	1.53	1.53	—	8.0 (4.2-9.1)	2500 (950-2880)	11.44 (4.59-12.78)	51
		18	16	10	10	—	2.68	2.42	1.45	1.45	—	8.0 (4.2-9.2)	2500 (950-2900)	11.44 (4.59-12.87)	51
		18	18	10	10	—	2.60	2.60	1.40	1.40	—	8.0 (4.2-9.2)	2500 (950-2900)	11.44 (4.59-12.87)	51
		13	13	13	10	—	2.14	2.14	2.14	1.57	—	8.0 (4.2-9.1)	2500 (950-2880)	11.44 (4.59-12.78)	51
		16	13	13	10	—	2.47	2.03	2.03	1.48	—	8.0 (4.2-9.2)	2500 (950-2900)	11.44 (4.59-12.87)	51
		16	16	13	10	—	2.34	2.34	1.92	1.40	—	8.0 (4.2-9.2)	2500 (950-2900)	11.44 (4.59-12.87)	51
		18	13	13	10	—	2.65	1.96	1.96	1.43	—	8.0 (4.2-9.2)	2500 (950-2900)	11.44 (4.59-12.87)	51
		18	16	13	10	—	2.52	2.26	1.86	1.36	—	8.0 (4.2-9.2)	2500 (950-2900)	11.44 (4.59-12.87)	51
		18	18	13	10	—	2.44	2.44	1.80	1.32	—	8.0 (4.2-9.2)	2500 (950-2900)	11.44 (4.59-12.87)	51
		13	13	13	13	—	2.00	2.00	2.00	2.00	—	8.0 (4.2-9.2)	2500 (950-2900)	11.44 (4.59-12.87)	51
16	13	13	13	—	2.31	1.90	1.90	1.90	—	8.0 (4.2-9.2)	2500 (950-2900)	11.44 (4.59-12.87)	51		
18	13	13	13	—	2.48	1.84	1.84	1.84	—	8.0 (4.2-9.2)	2500 (950-2900)	11.44 (4.59-12.87)	51		
16	16	13	13	—	2.20	2.20	1.80	1.80	—	8.0 (4.2-9.2)	2500 (950-2900)	11.44 (4.59-12.87)	51		
18	16	13	13	—	2.37	2.13	1.75	1.75	—	8.0 (4.2-9.2)	2500 (950-2900)	11.44 (4.59-12.87)	51		
18	18	13	13	—	2.30	2.30	1.70	1.70	—	8.0 (4.2-9.2)	2500 (950-2900)	11.44 (4.59-12.87)	51		

• The above specification values are those under the conditions that the indoor DB/WB=27/19°C and the outdoor DB/WB=35/—°C.



<Cooling/230V> (Continued)

Power supply (V)	Operating status	Indoor unit					Unit Capacity					Total			Outdoor noise (dB)
		A	B	C	D	E	A	B	C	D	E	Cooling capacity (kW)	Power consumption (W)	Operating current (A)	
230	5 units	07	07	07	07	07	1.96	1.96	1.96	1.96	1.96	9.8 (3.7 - 10.8)	2865 (950 - 3630)	13.11 (4.59 - 16.10)	51
		10	07	07	07	07	2.50	1.85	1.85	1.85	1.85	9.9 (3.7 - 10.9)	2894 (950 - 3670)	13.24 (4.59 - 16.28)	51
		13	07	07	07	07	3.13	1.69	1.69	1.69	1.69	9.9 (3.7 - 10.9)	2894 (950 - 3670)	13.24 (4.59 - 16.28)	51
		16	07	07	07	07	3.56	1.58	1.58	1.58	1.58	9.9 (3.7 - 10.9)	2894 (950 - 3670)	13.24 (4.59 - 16.28)	51
		18	07	07	07	07	3.81	1.52	1.52	1.52	1.52	9.9 (3.7 - 10.9)	2894 (950 - 3670)	13.24 (4.59 - 16.28)	51
		10	10	07	07	07	2.34	2.34	1.74	1.74	1.74	9.9 (3.7 - 10.9)	2894 (950 - 3670)	13.24 (4.59 - 16.28)	51
		13	10	07	07	07	2.95	2.16	1.60	1.60	1.60	9.9 (3.7 - 10.9)	2894 (950 - 3670)	13.24 (4.59 - 16.28)	51
		16	10	07	07	07	3.38	2.03	1.50	1.50	1.50	9.9 (3.7 - 10.9)	2894 (950 - 3670)	13.24 (4.59 - 16.28)	51
		18	10	07	07	07	3.61	1.95	1.45	1.45	1.45	9.9 (3.7 - 10.9)	2894 (950 - 3670)	13.24 (4.59 - 16.28)	51
		13	13	07	07	07	2.73	2.73	1.48	1.48	1.48	9.9 (3.7 - 10.9)	2894 (950 - 3670)	13.24 (4.59 - 16.28)	51
		16	13	07	07	07	3.14	2.58	1.39	1.39	1.39	9.9 (3.7 - 10.9)	2894 (950 - 3670)	13.24 (4.59 - 16.28)	51
		18	13	07	07	07	3.37	2.49	1.35	1.35	1.35	9.9 (3.7 - 10.9)	2894 (950 - 3670)	13.24 (4.59 - 16.28)	51
		16	16	07	07	07	2.97	2.97	1.32	1.32	1.32	9.9 (3.7 - 10.9)	2894 (950 - 3670)	13.24 (4.59 - 16.28)	51
		18	16	07	07	07	3.19	2.87	1.28	1.28	1.28	9.9 (3.7 - 10.9)	2894 (950 - 3670)	13.24 (4.59 - 16.28)	51
		10	10	10	07	07	2.21	2.21	2.21	1.64	1.64	9.9 (3.7 - 10.9)	2894 (950 - 3670)	13.24 (4.59 - 16.28)	51
		13	10	10	07	07	2.80	2.04	2.04	1.51	1.51	9.9 (3.7 - 10.9)	2894 (950 - 3670)	13.24 (4.59 - 16.28)	51
		13	13	10	07	07	2.60	2.60	1.90	1.40	1.40	9.9 (3.7 - 10.9)	2894 (950 - 3670)	13.24 (4.59 - 16.28)	51
		16	10	10	07	07	3.21	1.92	1.92	1.42	1.42	9.9 (3.7 - 10.9)	2894 (950 - 3670)	13.24 (4.59 - 16.28)	51
		18	10	10	07	07	3.44	1.86	1.86	1.38	1.38	9.9 (3.7 - 10.9)	2894 (950 - 3670)	13.24 (4.59 - 16.28)	51
		13	13	13	07	07	2.43	2.43	2.43	1.31	1.31	9.9 (3.7 - 10.9)	2894 (950 - 3670)	13.24 (4.59 - 16.28)	51
		16	13	13	07	07	2.80	2.30	2.30	1.25	1.25	9.9 (3.7 - 10.9)	2894 (950 - 3670)	13.24 (4.59 - 16.28)	51
		18	13	13	07	07	3.02	2.23	2.23	1.21	1.21	9.9 (3.7 - 10.9)	2894 (950 - 3670)	13.24 (4.59 - 16.28)	51
		16	16	10	07	07	2.84	2.84	1.70	1.26	1.26	9.9 (3.7 - 10.9)	2894 (950 - 3670)	13.24 (4.59 - 16.28)	51
		18	16	10	07	07	3.06	2.75	1.65	1.22	1.22	9.9 (3.7 - 10.9)	2894 (950 - 3670)	13.24 (4.59 - 16.28)	51
		16	16	13	07	07	2.67	2.67	2.19	1.19	1.19	9.9 (3.7 - 10.9)	2894 (950 - 3670)	13.24 (4.59 - 16.28)	51
		18	16	13	07	07	2.88	2.59	2.13	1.15	1.15	9.9 (3.7 - 10.9)	2894 (950 - 3670)	13.24 (4.59 - 16.28)	51
		10	10	10	10	07	2.09	2.09	2.09	2.09	2.09	9.9 (3.7 - 10.9)	2894 (950 - 3670)	13.24 (4.59 - 16.28)	51
		13	10	10	10	07	2.65	1.94	1.94	1.94	1.94	9.9 (3.7 - 10.9)	2894 (950 - 3670)	13.24 (4.59 - 16.28)	51
		16	10	10	10	07	3.05	1.83	1.83	1.83	1.83	9.9 (3.7 - 10.9)	2894 (950 - 3670)	13.24 (4.59 - 16.28)	51
		13	13	10	10	07	2.48	2.48	1.81	1.81	1.81	9.9 (3.7 - 10.9)	2894 (950 - 3670)	13.24 (4.59 - 16.28)	51
		16	13	10	10	07	2.86	2.35	1.71	1.71	1.71	9.9 (3.7 - 10.9)	2894 (950 - 3670)	13.24 (4.59 - 16.28)	51
		16	16	10	10	07	2.72	2.72	1.63	1.63	1.63	9.9 (3.7 - 10.9)	2894 (950 - 3670)	13.24 (4.59 - 16.28)	51
		13	13	13	10	07	2.32	2.32	2.32	1.69	1.69	9.9 (3.7 - 10.9)	2894 (950 - 3670)	13.24 (4.59 - 16.28)	51
		16	13	13	10	07	2.68	2.21	2.21	1.61	1.61	9.9 (3.7 - 10.9)	2894 (950 - 3670)	13.24 (4.59 - 16.28)	51
		16	16	13	10	07	2.56	2.56	2.11	1.54	1.54	9.9 (3.7 - 10.9)	2894 (950 - 3670)	13.24 (4.59 - 16.28)	51
		13	13	13	13	07	2.18	2.18	2.18	2.18	2.18	9.9 (3.7 - 10.9)	2894 (950 - 3670)	13.24 (4.59 - 16.28)	51
		16	13	13	13	07	2.53	2.08	2.08	2.08	2.08	9.9 (3.7 - 10.9)	2894 (950 - 3670)	13.24 (4.59 - 16.28)	51
		16	16	13	13	07	2.42	2.42	1.99	1.99	1.99	9.9 (3.7 - 10.9)	2894 (950 - 3670)	13.24 (4.59 - 16.28)	51
		10	10	10	10	10	1.98	1.98	1.98	1.98	1.98	9.9 (3.7 - 10.9)	2894 (950 - 3670)	13.24 (4.59 - 16.28)	51
		13	10	10	10	10	2.53	1.84	1.84	1.84	1.84	9.9 (3.7 - 10.9)	2894 (950 - 3670)	13.24 (4.59 - 16.28)	51
16	10	10	10	10	2.91	1.75	1.75	1.75	1.75	9.9 (3.7 - 10.9)	2894 (950 - 3670)	13.24 (4.59 - 16.28)	51		
18	10	10	10	10	3.13	1.69	1.69	1.69	1.69	9.9 (3.7 - 10.9)	2894 (950 - 3670)	13.24 (4.59 - 16.28)	51		
13	13	10	10	10	2.36	2.36	1.72	1.72	1.72	9.9 (3.7 - 10.9)	2894 (950 - 3670)	13.24 (4.59 - 16.28)	51		
16	13	10	10	10	2.73	2.25	1.64	1.64	1.64	9.9 (3.7 - 10.9)	2894 (950 - 3670)	13.24 (4.59 - 16.28)	51		
18	13	10	10	10	2.95	2.18	1.59	1.59	1.59	9.9 (3.7 - 10.9)	2894 (950 - 3670)	13.24 (4.59 - 16.28)	51		
16	16	10	10	10	2.61	2.61	1.56	1.56	1.56	9.9 (3.7 - 10.9)	2894 (950 - 3670)	13.24 (4.59 - 16.28)	51		
13	13	13	10	10	2.22	2.22	2.22	1.62	1.62	9.9 (3.7 - 10.9)	2894 (950 - 3670)	13.24 (4.59 - 16.28)	51		
16	13	13	10	10	2.58	2.12	2.12	1.55	1.55	9.9 (3.7 - 10.9)	2894 (950 - 3670)	13.24 (4.59 - 16.28)	51		
18	13	13	10	10	2.78	2.06	2.06	1.50	1.50	9.9 (3.7 - 10.9)	2894 (950 - 3670)	13.24 (4.59 - 16.28)	51		
16	16	13	10	10	2.49	2.49	2.04	1.49	1.49	10.0 (3.7 - 11.0)	2923 (950 - 3700)	13.38 (4.59 - 16.42)	51		
13	13	13	13	10	2.09	2.09	2.09	2.09	2.09	9.9 (3.7 - 10.9)	2894 (950 - 3670)	13.24 (4.59 - 16.28)	51		
16	13	13	13	10	2.46	2.02	2.02	2.02	2.02	10.0 (3.7 - 11.0)	2923 (950 - 3700)	13.38 (4.59 - 16.42)	51		
18	13	13	13	10	2.66	1.97	1.97	1.97	1.97	10.0 (3.7 - 11.0)	2923 (950 - 3700)	13.38 (4.59 - 16.42)	51		
16	16	13	13	10	2.36	2.36	1.94	1.94	1.94	10.0 (3.7 - 11.0)	2923 (950 - 3700)	13.38 (4.59 - 16.42)	51		
13	13	13	13	13	2.00	2.00	2.00	2.00	2.00	10.0 (3.7 - 11.0)	2923 (950 - 3700)	13.38 (4.59 - 16.42)	51		
16	13	13	13	13	2.33	1.92	1.92	1.92	1.92	10.0 (3.7 - 11.0)	2923 (950 - 3700)	13.38 (4.59 - 16.42)	51		

• The above specification values are those under the conditions that the indoor DB/WB=27/19°C and the outdoor DB/WB=35/—°C.



# Outdoor Unit : RAS-5M34UAV-E

## <Cooling/240V>

Power supply (V)	Operating status	Indoor unit					Unit Capacity					Total			Outdoor noise (dB)
		A	B	C	D	E	A	B	C	D	E	Cooling capacity (kW)	Power consumption (W)	Operating current (A)	
240	1 unit	07	—	—	—	—	2.0	—	—	—	—	2.0 (1.4 - 2.5)	650 (640 - 700)	3.52 (3.51 - 3.43)	51
		10	—	—	—	—	2.7	—	—	—	—	2.7 (1.4 - 3.2)	750 (640 - 950)	4.06 (3.51 - 4.26)	51
		13	—	—	—	—	3.7	—	—	—	—	3.7 (1.4 - 4.4)	1200 (640 - 1520)	5.68 (3.38 - 6.60)	51
		16	—	—	—	—	4.5	—	—	—	—	4.5 (1.4 - 5.0)	1650 (640 - 2000)	7.31 (3.38 - 8.50)	51
		18	—	—	—	—	5.0	—	—	—	—	5.0 (1.4 - 5.2)	1950 (640 - 2100)	8.55 (3.38 - 8.93)	51
	2 units	07	07	—	—	—	2.00	2.00	—	—	—	4.0 (2.5 - 5.0)	1520 (640 - 1770)	6.67 (3.33 - 7.53)	51
		10	07	—	—	—	2.70	2.00	—	—	—	4.7 (2.5 - 5.7)	1530 (640 - 1910)	6.71 (3.33 - 8.12)	51
		13	07	—	—	—	3.70	2.00	—	—	—	5.7 (2.6 - 6.5)	1810 (660 - 2130)	7.94 (3.44 - 9.06)	51
		16	07	—	—	—	4.08	1.82	—	—	—	5.9 (2.7 - 6.6)	1810 (660 - 2220)	7.94 (3.44 - 9.44)	51
		18	07	—	—	—	4.50	1.80	—	—	—	6.3 (2.9 - 6.9)	2040 (670 - 2400)	8.95 (3.49 - 10.20)	51
		10	10	—	—	—	2.70	2.70	—	—	—	5.4 (2.5 - 6.3)	1530 (640 - 2040)	6.71 (3.33 - 8.67)	51
		13	10	—	—	—	3.41	2.49	—	—	—	5.9 (2.7 - 6.6)	1810 (660 - 2220)	7.94 (3.44 - 9.44)	51
		16	10	—	—	—	3.94	2.36	—	—	—	6.3 (2.9 - 6.9)	2040 (670 - 2400)	8.95 (3.49 - 10.20)	51
		18	10	—	—	—	4.09	2.21	—	—	—	6.3 (2.9 - 6.9)	2040 (670 - 2400)	8.95 (3.49 - 10.20)	51
		13	13	—	—	—	3.15	3.15	—	—	—	6.3 (2.9 - 6.9)	2040 (670 - 2400)	8.95 (3.49 - 10.20)	51
		16	13	—	—	—	3.73	3.07	—	—	—	6.8 (3.0 - 7.2)	2320 (690 - 2570)	10.18 (3.59 - 10.93)	51
		18	13	—	—	—	3.91	2.89	—	—	—	6.8 (3.0 - 7.2)	2320 (690 - 2570)	10.18 (3.59 - 10.93)	51
		16	16	—	—	—	3.60	3.60	—	—	—	7.2 (3.2 - 7.5)	2550 (700 - 2750)	11.18 (3.65 - 11.69)	51
		18	16	—	—	—	3.79	3.41	—	—	—	7.2 (3.2 - 7.5)	2550 (700 - 2750)	11.18 (3.65 - 11.69)	51
		18	18	—	—	—	3.60	3.60	—	—	—	7.2 (3.2 - 7.5)	2550 (700 - 2750)	11.18 (3.65 - 11.69)	51
	3 units	07	07	07	—	—	2.00	2.00	2.00	—	—	6.0 (3.8 - 7.5)	2400 (950 - 2720)	10.53 (4.40 - 11.56)	51
		10	07	07	—	—	2.70	2.00	2.00	—	—	6.7 (3.8 - 8.2)	2400 (950 - 2720)	10.53 (4.40 - 11.56)	51
		13	07	07	—	—	3.65	1.97	1.97	—	—	7.6 (3.9 - 8.3)	2410 (960 - 2740)	10.57 (4.44 - 11.65)	51
		16	07	07	—	—	4.08	1.81	1.81	—	—	7.7 (4.0 - 8.5)	2410 (960 - 2790)	10.57 (4.44 - 11.86)	51
		18	07	07	—	—	4.28	1.71	1.71	—	—	7.7 (4.0 - 8.5)	2410 (960 - 2790)	10.57 (4.44 - 11.86)	51
		10	10	07	—	—	2.70	2.70	2.00	—	—	7.4 (3.8 - 8.2)	2400 (950 - 2720)	10.53 (4.40 - 11.56)	51
		13	10	07	—	—	3.39	2.48	1.83	—	—	7.7 (3.9 - 8.3)	2410 (960 - 2740)	10.57 (4.44 - 11.65)	51
		16	10	07	—	—	3.77	2.26	1.67	—	—	7.7 (4.0 - 8.5)	2410 (960 - 2790)	10.57 (4.44 - 11.86)	51
		18	10	07	—	—	3.97	2.14	1.59	—	—	7.7 (4.0 - 8.5)	2410 (960 - 2790)	10.57 (4.44 - 11.86)	51
		13	13	07	—	—	3.03	3.03	1.64	—	—	7.7 (4.0 - 8.5)	2410 (960 - 2790)	10.57 (4.44 - 11.86)	51
		16	13	07	—	—	3.44	2.83	1.53	—	—	7.8 (4.1 - 8.6)	2430 (970 - 2810)	10.66 (4.49 - 11.95)	51
		18	13	07	—	—	3.64	2.70	1.46	—	—	7.8 (4.1 - 8.6)	2430 (970 - 2810)	10.66 (4.49 - 11.95)	51
		16	16	07	—	—	3.19	3.19	1.42	—	—	7.8 (4.1 - 8.6)	2430 (970 - 2810)	10.66 (4.49 - 11.95)	51
		18	16	07	—	—	3.39	3.05	1.36	—	—	7.8 (4.1 - 8.6)	2430 (970 - 2810)	10.66 (4.49 - 11.95)	51
		18	18	07	—	—	3.29	3.29	1.32	—	—	7.9 (4.1 - 8.7)	2440 (970 - 2830)	10.70 (4.49 - 12.03)	51
		10	10	10	—	—	2.53	2.53	2.53	—	—	7.6 (3.8 - 8.2)	2400 (950 - 2720)	10.53 (4.40 - 11.56)	51
		13	10	10	—	—	3.13	2.28	2.28	—	—	7.7 (3.9 - 8.3)	2410 (960 - 2740)	10.57 (4.44 - 11.65)	51
		16	10	10	—	—	3.50	2.10	2.10	—	—	7.7 (4.0 - 8.5)	2410 (960 - 2790)	10.57 (4.44 - 11.86)	51
		18	10	10	—	—	3.70	2.00	2.00	—	—	7.7 (4.0 - 8.5)	2410 (960 - 2790)	10.57 (4.44 - 11.86)	51
		13	13	10	—	—	2.82	2.82	2.06	—	—	7.7 (4.0 - 8.5)	2410 (960 - 2790)	10.57 (4.44 - 11.86)	51
		16	13	10	—	—	3.22	2.65	1.93	—	—	7.8 (4.1 - 8.6)	2430 (970 - 2810)	10.66 (4.49 - 11.95)	51
		18	13	10	—	—	3.42	2.53	1.85	—	—	7.8 (4.1 - 8.6)	2430 (970 - 2810)	10.66 (4.49 - 11.95)	51
		16	16	10	—	—	3.04	3.04	1.82	—	—	7.9 (4.1 - 8.7)	2440 (970 - 2830)	10.70 (4.49 - 12.03)	51
		18	16	10	—	—	3.20	2.88	1.73	—	—	7.8 (4.1 - 8.6)	2430 (970 - 2810)	10.66 (4.49 - 11.95)	51
		18	18	10	—	—	3.11	3.11	1.68	—	—	7.9 (4.1 - 8.7)	2440 (970 - 2830)	10.70 (4.49 - 12.03)	51
13		13	13	—	—	2.60	2.60	2.60	—	—	7.8 (4.1 - 8.6)	2430 (970 - 2810)	10.66 (4.49 - 11.95)	51	
16		13	13	—	—	2.99	2.46	2.46	—	—	7.9 (4.1 - 8.7)	2440 (970 - 2830)	10.70 (4.49 - 12.03)	51	
18		13	13	—	—	3.19	2.36	2.36	—	—	7.9 (4.1 - 8.7)	2440 (970 - 2830)	10.70 (4.49 - 12.03)	51	
16		16	13	—	—	2.80	2.80	2.30	—	—	7.9 (4.1 - 8.7)	2440 (970 - 2830)	10.70 (4.49 - 12.03)	51	
18		16	13	—	—	2.99	2.69	2.21	—	—	7.9 (4.1 - 8.7)	2440 (970 - 2830)	10.70 (4.49 - 12.03)	51	
18	18	13	—	—	2.88	2.88	2.13	—	—	7.9 (4.1 - 8.7)	2440 (970 - 2830)	10.70 (4.49 - 12.03)	51		

• The above specification values are those under the conditions that the indoor DB/WB=27/19°C and the outdoor DB/WB=35/—°C.

<Cooling/240V> (Continued)

Power supply (V)	Operating status	Indoor unit					Unit Capacity					Total			Outdoor noise (dB)
		A	B	C	D	E	A	B	C	D	E	Cooling capacity (kW)	Power consumption (W)	Operating current (A)	
240	4 units	07	07	07	07	—	1.95	1.95	1.95	1.95	—	7.8 (4.0-8.7)	2450 (930-2800)	10.75 (4.31-11.90)	51
		10	07	07	07	—	2.42	1.79	1.79	1.79	—	7.8 (4.0-8.7)	2450 (930-2800)	10.75 (4.31-11.90)	51
		13	07	07	07	—	3.01	1.63	1.63	1.63	—	7.9 (4.1-8.8)	2450 (940-2820)	10.75 (4.35-11.99)	51
		16	07	07	07	—	3.39	1.50	1.50	1.50	—	7.9 (4.1-9.0)	2500 (940-2860)	10.96 (4.35-12.16)	51
		18	07	07	07	—	3.59	1.44	1.44	1.44	—	7.9 (4.1-9.0)	2500 (940-2860)	10.96 (4.35-12.16)	51
		10	10	07	07	—	2.24	2.24	1.66	1.66	—	7.8 (4.0-8.7)	2450 (930-2800)	10.75 (4.31-11.90)	51
		13	10	07	07	—	2.81	2.05	1.52	1.52	—	7.9 (4.1-8.8)	2450 (940-2820)	10.75 (4.35-11.99)	51
		16	10	07	07	—	3.17	1.90	1.41	1.41	—	7.9 (4.1-9.0)	2500 (940-2860)	10.96 (4.35-12.16)	51
		18	10	07	07	—	3.38	1.82	1.35	1.35	—	7.9 (4.1-9.0)	2500 (940-2860)	10.96 (4.35-12.16)	51
		13	13	07	07	—	2.56	2.56	1.39	1.39	—	7.9 (4.1-9.0)	2500 (940-2860)	10.96 (4.35-12.16)	51
		16	13	07	07	—	2.95	2.43	1.31	1.31	—	8.0 (4.2-9.1)	2500 (950-2880)	10.96 (4.40-12.24)	51
		18	13	07	07	—	3.15	2.33	1.26	1.26	—	8.0 (4.2-9.1)	2500 (950-2880)	10.96 (4.40-12.24)	51
		16	16	07	07	—	2.77	2.77	1.23	1.23	—	8.0 (4.2-9.2)	2500 (950-2900)	10.96 (4.40-12.33)	51
		18	16	07	07	—	2.96	2.67	1.19	1.19	—	8.0 (4.2-9.2)	2500 (950-2900)	10.96 (4.40-12.33)	51
		18	18	07	07	—	2.86	2.86	1.14	1.14	—	8.0 (4.2-9.2)	2500 (950-2900)	10.96 (4.40-12.33)	51
		10	10	10	07	—	2.11	2.11	2.11	1.56	—	7.9 (4.0-8.7)	2450 (930-2800)	10.75 (4.31-11.90)	51
		13	10	10	07	—	2.63	1.92	1.92	1.42	—	7.9 (4.1-8.8)	2450 (940-2820)	10.75 (4.35-11.99)	51
		16	10	10	07	—	2.99	1.79	1.79	1.33	—	7.9 (4.1-9.0)	2500 (940-2860)	10.96 (4.35-12.16)	51
		18	10	10	07	—	3.23	1.74	1.74	1.29	—	8.0 (4.1-9.0)	2500 (940-2860)	10.96 (4.35-12.16)	51
		13	13	10	07	—	2.45	2.45	1.79	1.32	—	8.0 (4.1-9.0)	2500 (940-2860)	10.96 (4.35-12.16)	51
		16	13	10	07	—	2.79	2.29	1.67	1.24	—	8.0 (4.2-9.1)	2500 (950-2880)	10.96 (4.40-12.24)	51
		18	13	10	07	—	2.99	2.21	1.61	1.19	—	8.0 (4.2-9.1)	2500 (950-2880)	10.96 (4.40-12.24)	51
		16	16	10	07	—	2.63	2.63	1.58	1.17	—	8.0 (4.2-9.2)	2500 (950-2900)	10.96 (4.40-12.33)	51
		18	16	10	07	—	2.82	2.54	1.52	1.13	—	8.0 (4.2-9.2)	2500 (950-2900)	10.96 (4.40-12.33)	51
		18	18	10	07	—	2.72	2.72	1.47	1.09	—	8.0 (4.2-9.2)	2500 (950-2900)	10.96 (4.40-12.33)	51
		13	13	13	07	—	2.26	2.26	2.26	1.22	—	8.0 (4.2-9.1)	2500 (950-2880)	10.96 (4.40-12.24)	51
		16	13	13	07	—	2.59	2.13	2.13	1.15	—	8.0 (4.2-9.2)	2500 (950-2900)	10.96 (4.40-12.33)	51
		18	13	13	07	—	2.78	2.06	2.06	1.11	—	8.0 (4.2-9.2)	2500 (950-2900)	10.96 (4.40-12.33)	51
		16	16	13	07	—	2.45	2.45	2.01	1.09	—	8.0 (4.2-9.2)	2500 (950-2900)	10.96 (4.40-12.33)	51
		18	16	13	07	—	2.63	2.37	1.95	1.05	—	8.0 (4.2-9.2)	2500 (950-2900)	10.96 (4.40-12.33)	51
		18	18	13	07	—	2.55	2.55	1.89	1.02	—	8.0 (4.2-9.2)	2500 (950-2900)	10.96 (4.40-12.33)	51
		10	10	10	10	—	1.98	1.98	1.98	1.98	—	7.9 (4.0-8.7)	2450 (930-2800)	10.75 (4.31-11.90)	51
		13	10	10	10	—	2.48	1.81	1.81	1.81	—	7.9 (4.1-8.8)	2450 (940-2820)	10.75 (4.35-11.99)	51
		16	10	10	10	—	2.86	1.71	1.71	1.71	—	8.0 (4.1-9.0)	2500 (940-2860)	10.96 (4.35-12.16)	51
		18	10	10	10	—	3.05	1.65	1.65	1.65	—	8.0 (4.1-9.0)	2500 (940-2860)	10.96 (4.35-12.16)	51
		13	13	10	10	—	2.31	2.31	1.69	1.69	—	8.0 (4.1-9.0)	2500 (940-2860)	10.96 (4.35-12.16)	51
		16	13	10	10	—	2.65	2.18	1.59	1.59	—	8.0 (4.2-9.1)	2500 (950-2880)	10.96 (4.40-12.24)	51
		16	16	10	10	—	2.50	2.50	1.50	1.50	—	8.0 (4.2-9.2)	2500 (950-2900)	10.96 (4.40-12.33)	51
		18	13	10	10	—	2.84	2.10	1.53	1.53	—	8.0 (4.2-9.1)	2500 (950-2880)	10.96 (4.40-12.24)	51
		18	16	10	10	—	2.68	2.42	1.45	1.45	—	8.0 (4.2-9.2)	2500 (950-2900)	10.96 (4.40-12.33)	51
		18	18	10	10	—	2.60	2.60	1.40	1.40	—	8.0 (4.2-9.2)	2500 (950-2900)	10.96 (4.40-12.33)	51
		13	13	13	10	—	2.14	2.14	2.14	1.57	—	8.0 (4.2-9.1)	2500 (950-2880)	10.96 (4.40-12.24)	51
		16	13	13	10	—	2.47	2.03	2.03	1.48	—	8.0 (4.2-9.2)	2500 (950-2900)	10.96 (4.40-12.33)	51
		16	16	13	10	—	2.34	2.34	1.92	1.40	—	8.0 (4.2-9.2)	2500 (950-2900)	10.96 (4.40-12.33)	51
		18	13	13	10	—	2.65	1.96	1.96	1.43	—	8.0 (4.2-9.2)	2500 (950-2900)	10.96 (4.40-12.33)	51
		18	16	13	10	—	2.52	2.26	1.86	1.36	—	8.0 (4.2-9.2)	2500 (950-2900)	10.96 (4.40-12.33)	51
		18	18	13	10	—	2.44	2.44	1.80	1.32	—	8.0 (4.2-9.2)	2500 (950-2900)	10.96 (4.40-12.33)	51
		13	13	13	13	—	2.00	2.00	2.00	2.00	—	8.0 (4.2-9.2)	2500 (950-2900)	10.96 (4.40-12.33)	51
16	13	13	13	—	2.31	1.90	1.90	1.90	—	8.0 (4.2-9.2)	2500 (950-2900)	10.96 (4.40-12.33)	51		
18	13	13	13	—	2.48	1.84	1.84	1.84	—	8.0 (4.2-9.2)	2500 (950-2900)	10.96 (4.40-12.33)	51		
16	16	13	13	—	2.20	2.20	1.80	1.80	—	8.0 (4.2-9.2)	2500 (950-2900)	10.96 (4.40-12.33)	51		
18	16	13	13	—	2.37	2.13	1.75	1.75	—	8.0 (4.2-9.2)	2500 (950-2900)	10.96 (4.40-12.33)	51		
18	18	13	13	—	2.30	2.30	1.70	1.70	—	8.0 (4.2-9.2)	2500 (950-2900)	10.96 (4.40-12.33)	51		

• The above specification values are those under the conditions that the indoor DB/WB=27/19°C and the outdoor DB/WB=35/—°C.

<Cooling/240V> (Continued)

Power supply (V)	Operating status	Indoor unit					Unit Capacity					Total			Outdoor noise (dB)
		A	B	C	D	E	A	B	C	D	E	Cooling capacity (kW)	Power consumption (W)	Operating current (A)	
240	5 units	07	07	07	07	07	1.96	1.96	1.96	1.96	1.96	9.8 (3.7 - 10.8)	2865 (950 - 3630)	12.57 (4.40 - 15.43)	51
		10	07	07	07	07	2.50	1.85	1.85	1.85	1.85	9.9 (3.7 - 10.9)	2894 (950 - 3670)	12.69 (4.40 - 15.60)	51
		13	07	07	07	07	3.13	1.69	1.69	1.69	1.69	9.9 (3.7 - 10.9)	2894 (950 - 3670)	12.69 (4.40 - 15.60)	51
		16	07	07	07	07	3.56	1.58	1.58	1.58	1.58	9.9 (3.7 - 10.9)	2894 (950 - 3670)	12.69 (4.40 - 15.60)	51
		18	07	07	07	07	3.81	1.52	1.52	1.52	1.52	9.9 (3.7 - 10.9)	2894 (950 - 3670)	12.69 (4.40 - 15.60)	51
		10	10	07	07	07	2.34	2.34	1.74	1.74	1.74	9.9 (3.7 - 10.9)	2894 (950 - 3670)	12.69 (4.40 - 15.60)	51
		13	10	07	07	07	2.95	2.16	1.60	1.60	1.60	9.9 (3.7 - 10.9)	2894 (950 - 3670)	12.69 (4.40 - 15.60)	51
		16	10	07	07	07	3.38	2.03	1.50	1.50	1.50	9.9 (3.7 - 10.9)	2894 (950 - 3670)	12.69 (4.40 - 15.60)	51
		18	10	07	07	07	3.61	1.95	1.45	1.45	1.45	9.9 (3.7 - 10.9)	2894 (950 - 3670)	12.69 (4.40 - 15.60)	51
		13	13	07	07	07	2.73	2.73	1.48	1.48	1.48	9.9 (3.7 - 10.9)	2894 (950 - 3670)	12.69 (4.40 - 15.60)	51
		16	13	07	07	07	3.14	2.58	1.39	1.39	1.39	9.9 (3.7 - 10.9)	2894 (950 - 3670)	12.69 (4.40 - 15.60)	51
		18	13	07	07	07	3.37	2.49	1.35	1.35	1.35	9.9 (3.7 - 10.9)	2894 (950 - 3670)	12.69 (4.40 - 15.60)	51
		16	16	07	07	07	2.97	2.97	1.32	1.32	1.32	9.9 (3.7 - 10.9)	2894 (950 - 3670)	12.69 (4.40 - 15.60)	51
		18	16	07	07	07	3.19	2.87	1.28	1.28	1.28	9.9 (3.7 - 10.9)	2894 (950 - 3670)	12.69 (4.40 - 15.60)	51
		10	10	10	07	07	2.21	2.21	2.21	1.64	1.64	9.9 (3.7 - 10.9)	2894 (950 - 3670)	12.69 (4.40 - 15.60)	51
		13	10	10	07	07	2.80	2.04	2.04	1.51	1.51	9.9 (3.7 - 10.9)	2894 (950 - 3670)	12.69 (4.40 - 15.60)	51
		13	13	10	07	07	2.60	2.60	1.90	1.40	1.40	9.9 (3.7 - 10.9)	2894 (950 - 3670)	12.69 (4.40 - 15.60)	51
		16	10	10	07	07	3.21	1.92	1.92	1.42	1.42	9.9 (3.7 - 10.9)	2894 (950 - 3670)	12.69 (4.40 - 15.60)	51
		18	10	10	07	07	3.44	1.86	1.86	1.38	1.38	9.9 (3.7 - 10.9)	2894 (950 - 3670)	12.69 (4.40 - 15.60)	51
		13	13	13	07	07	2.43	2.43	2.43	1.31	1.31	9.9 (3.7 - 10.9)	2894 (950 - 3670)	12.69 (4.40 - 15.60)	51
		16	13	13	07	07	2.80	2.30	2.30	1.25	1.25	9.9 (3.7 - 10.9)	2894 (950 - 3670)	12.69 (4.40 - 15.60)	51
		18	13	13	07	07	3.02	2.23	2.23	1.21	1.21	9.9 (3.7 - 10.9)	2894 (950 - 3670)	12.69 (4.40 - 15.60)	51
		16	16	10	07	07	2.84	2.84	1.70	1.26	1.26	9.9 (3.7 - 10.9)	2894 (950 - 3670)	12.69 (4.40 - 15.60)	51
		18	16	10	07	07	3.06	2.75	1.65	1.22	1.22	9.9 (3.7 - 10.9)	2894 (950 - 3670)	12.69 (4.40 - 15.60)	51
		16	16	13	07	07	2.67	2.67	2.19	1.19	1.19	9.9 (3.7 - 10.9)	2894 (950 - 3670)	12.69 (4.40 - 15.60)	51
		18	16	13	07	07	2.88	2.59	2.13	1.15	1.15	9.9 (3.7 - 10.9)	2894 (950 - 3670)	12.69 (4.40 - 15.60)	51
		10	10	10	10	07	2.09	2.09	2.09	2.09	2.09	9.9 (3.7 - 10.9)	2894 (950 - 3670)	12.69 (4.40 - 15.60)	51
		13	10	10	10	07	2.65	1.94	1.94	1.94	1.94	9.9 (3.7 - 10.9)	2894 (950 - 3670)	12.69 (4.40 - 15.60)	51
		16	10	10	10	07	3.05	1.83	1.83	1.83	1.83	9.9 (3.7 - 10.9)	2894 (950 - 3670)	12.69 (4.40 - 15.60)	51
		13	13	10	10	07	2.48	2.48	1.81	1.81	1.81	9.9 (3.7 - 10.9)	2894 (950 - 3670)	12.69 (4.40 - 15.60)	51
		16	13	10	10	07	2.86	2.35	1.71	1.71	1.71	9.9 (3.7 - 10.9)	2894 (950 - 3670)	12.69 (4.40 - 15.60)	51
		16	16	10	10	07	2.72	2.72	1.63	1.63	1.63	9.9 (3.7 - 10.9)	2894 (950 - 3670)	12.69 (4.40 - 15.60)	51
		13	13	13	10	07	2.32	2.32	2.32	1.69	1.69	9.9 (3.7 - 10.9)	2894 (950 - 3670)	12.69 (4.40 - 15.60)	51
		16	13	13	10	07	2.68	2.21	2.21	1.61	1.61	9.9 (3.7 - 10.9)	2894 (950 - 3670)	12.69 (4.40 - 15.60)	51
		16	16	13	10	07	2.56	2.56	2.11	1.54	1.54	9.9 (3.7 - 10.9)	2894 (950 - 3670)	12.69 (4.40 - 15.60)	51
		13	13	13	13	07	2.18	2.18	2.18	2.18	2.18	9.9 (3.7 - 10.9)	2894 (950 - 3670)	12.69 (4.40 - 15.60)	51
		16	13	13	13	07	2.53	2.08	2.08	2.08	2.08	9.9 (3.7 - 10.9)	2894 (950 - 3670)	12.69 (4.40 - 15.60)	51
		16	16	13	13	07	2.42	2.42	1.99	1.99	1.99	9.9 (3.7 - 10.9)	2894 (950 - 3670)	12.69 (4.40 - 15.60)	51
		10	10	10	10	10	1.98	1.98	1.98	1.98	1.98	9.9 (3.7 - 10.9)	2894 (950 - 3670)	12.69 (4.40 - 15.60)	51
		13	10	10	10	10	2.53	1.84	1.84	1.84	1.84	9.9 (3.7 - 10.9)	2894 (950 - 3670)	12.69 (4.40 - 15.60)	51
16	10	10	10	10	2.91	1.75	1.75	1.75	1.75	9.9 (3.7 - 10.9)	2894 (950 - 3670)	12.69 (4.40 - 15.60)	51		
18	10	10	10	10	3.13	1.69	1.69	1.69	1.69	9.9 (3.7 - 10.9)	2894 (950 - 3670)	12.69 (4.40 - 15.60)	51		
13	13	10	10	10	2.36	2.36	1.72	1.72	1.72	9.9 (3.7 - 10.9)	2894 (950 - 3670)	12.69 (4.40 - 15.60)	51		
16	13	10	10	10	2.73	2.25	1.64	1.64	1.64	9.9 (3.7 - 10.9)	2894 (950 - 3670)	12.69 (4.40 - 15.60)	51		
18	13	10	10	10	2.95	2.18	1.59	1.59	1.59	9.9 (3.7 - 10.9)	2894 (950 - 3670)	12.69 (4.40 - 15.60)	51		
16	16	10	10	10	2.61	2.61	1.56	1.56	1.56	9.9 (3.7 - 10.9)	2894 (950 - 3670)	12.69 (4.40 - 15.60)	51		
13	13	13	10	10	2.22	2.22	2.22	1.62	1.62	9.9 (3.7 - 10.9)	2894 (950 - 3670)	12.69 (4.40 - 15.60)	51		
16	13	13	10	10	2.58	2.12	2.12	1.55	1.55	9.9 (3.7 - 10.9)	2894 (950 - 3670)	12.69 (4.40 - 15.60)	51		
18	13	13	10	10	2.78	2.06	2.06	1.50	1.50	9.9 (3.7 - 10.9)	2894 (950 - 3670)	12.69 (4.40 - 15.60)	51		
16	16	13	10	10	2.49	2.49	2.04	1.49	1.49	10.0 (3.7 - 11.0)	2923 (950 - 3700)	12.82 (4.40 - 15.73)	51		
13	13	13	13	10	2.09	2.09	2.09	2.09	2.09	9.9 (3.7 - 10.9)	2894 (950 - 3670)	12.69 (4.40 - 15.60)	51		
16	13	13	13	10	2.46	2.02	2.02	2.02	2.02	10.0 (3.7 - 11.0)	2923 (950 - 3700)	12.82 (4.40 - 15.73)	51		
18	13	13	13	10	2.66	1.97	1.97	1.97	1.97	10.0 (3.7 - 11.0)	2923 (950 - 3700)	12.82 (4.40 - 15.73)	51		
16	16	13	13	10	2.36	2.36	1.94	1.94	1.94	10.0 (3.7 - 11.0)	2923 (950 - 3700)	12.82 (4.40 - 15.73)	51		
13	13	13	13	13	2.00	2.00	2.00	2.00	2.00	10.0 (3.7 - 11.0)	2923 (950 - 3700)	12.82 (4.40 - 15.73)	51		
16	13	13	13	13	2.33	1.92	1.92	1.92	1.92	10.0 (3.7 - 11.0)	2923 (950 - 3700)	12.82 (4.40 - 15.73)	51		

• The above specification values are those under the conditions that the indoor DB/WB=27/19°C and the outdoor DB/WB=35/—°C.

# Outdoor Unit : RAS-5M34UAV-E

## <Heating/220V>

Power supply (V)	Operating status	Indoor unit					Unit Capacity					Total			Outdoor noise (dB)
		A	B	C	D	E	A	B	C	D	E	Heating capacity (kW)	Power consumption (W)	Operating current (A)	
220	1 unit	07	—	—	—	—	2.7	—	—	—	—	2.7 (0.8 - 3.7)	900 (300 - 1340)	4.70 (1.87 - 6.22)	54
		10	—	—	—	—	4.0	—	—	—	—	4.0 (0.8 - 5.2)	1450 (300 - 1980)	6.94 (1.87 - 9.18)	54
		13	—	—	—	—	5.0	—	—	—	—	5.0 (0.8 - 6.5)	2050 (310 - 2750)	9.81 (1.93 - 12.76)	54
		16	—	—	—	—	5.5	—	—	—	—	5.5 (0.8 - 6.9)	2400 (310 - 3000)	11.48 (1.93 - 13.91)	54
		18	—	—	—	—	6.0	—	—	—	—	6.0 (0.8 - 7.1)	2630 (310 - 3200)	12.58 (1.93 - 14.84)	54
	2 units	07	07	—	—	—	2.70	2.70	—	—	—	5.4 (1.5 - 7.4)	2050 (320 - 3200)	9.81 (1.94 - 14.84)	54
		10	07	—	—	—	4.00	2.70	—	—	—	6.7 (1.5 - 8.9)	2080 (320 - 3200)	9.95 (1.94 - 14.84)	54
		13	07	—	—	—	4.81	2.59	—	—	—	7.4 (1.5 - 10.1)	2320 (320 - 3210)	11.10 (1.94 - 14.89)	54
		16	07	—	—	—	5.10	2.50	—	—	—	7.6 (1.5 - 10.1)	2480 (320 - 3230)	11.87 (1.94 - 14.98)	54
		18	07	—	—	—	5.45	2.45	—	—	—	7.9 (1.5 - 10.1)	2480 (320 - 3230)	11.87 (1.94 - 14.98)	54
		10	10	—	—	—	3.60	3.60	—	—	—	7.2 (1.5 - 10.0)	2100 (320 - 3200)	10.05 (1.94 - 14.84)	54
		13	10	—	—	—	4.22	3.38	—	—	—	7.6 (1.5 - 10.1)	2320 (320 - 3210)	11.10 (1.94 - 14.89)	54
		16	10	—	—	—	4.57	3.33	—	—	—	7.9 (1.5 - 10.1)	2480 (320 - 3230)	11.87 (1.94 - 14.98)	54
		18	10	—	—	—	4.74	3.16	—	—	—	7.9 (1.5 - 10.1)	2480 (320 - 3230)	11.87 (1.94 - 14.98)	54
		13	13	—	—	—	3.95	3.95	—	—	—	7.9 (1.5 - 10.1)	2480 (320 - 3230)	11.87 (1.94 - 14.98)	54
		16	13	—	—	—	4.35	3.95	—	—	—	8.3 (1.5 - 10.2)	2700 (320 - 3240)	12.92 (1.94 - 15.03)	54
		18	13	—	—	—	4.53	3.77	—	—	—	8.3 (1.5 - 10.2)	2700 (320 - 3240)	12.92 (1.94 - 15.03)	54
		16	16	—	—	—	4.30	4.30	—	—	—	8.6 (1.5 - 10.2)	2860 (320 - 3250)	13.68 (1.94 - 15.07)	54
		18	16	—	—	—	4.49	4.11	—	—	—	8.6 (1.5 - 10.2)	2860 (320 - 3250)	13.68 (1.94 - 15.07)	54
		18	18	—	—	—	4.30	4.30	—	—	—	8.6 (1.5 - 10.2)	2860 (320 - 3250)	13.68 (1.94 - 15.07)	54
	3 units	07	07	07	—	—	2.70	2.70	2.70	—	—	8.1 (2.0 - 10.4)	2290 (380 - 2750)	10.96 (2.16 - 12.76)	54
		10	07	07	—	—	3.53	2.38	2.38	—	—	8.3 (2.0 - 10.4)	2300 (380 - 2750)	11.00 (2.16 - 12.76)	54
		13	07	07	—	—	4.13	2.23	2.23	—	—	8.6 (2.0 - 10.4)	2300 (380 - 2750)	11.00 (2.16 - 12.76)	54
		16	07	07	—	—	4.39	2.16	2.16	—	—	8.7 (2.0 - 10.5)	2350 (380 - 2760)	11.24 (2.16 - 12.80)	54
		18	07	07	—	—	4.58	2.06	2.06	—	—	8.7 (2.0 - 10.5)	2350 (380 - 2760)	11.24 (2.16 - 12.80)	54
		10	10	07	—	—	3.18	3.18	2.14	—	—	8.5 (2.0 - 10.4)	2300 (380 - 2750)	11.00 (2.16 - 12.76)	54
		13	10	07	—	—	3.72	2.97	2.01	—	—	8.7 (2.0 - 10.5)	2350 (380 - 2760)	11.24 (2.16 - 12.80)	54
		16	10	07	—	—	3.92	2.85	1.93	—	—	8.7 (2.0 - 10.5)	2350 (380 - 2760)	11.24 (2.16 - 12.80)	54
		18	10	07	—	—	4.11	2.74	1.85	—	—	8.7 (2.0 - 10.5)	2350 (380 - 2760)	11.24 (2.16 - 12.80)	54
		13	13	07	—	—	3.43	3.43	1.85	—	—	8.7 (2.0 - 10.5)	2350 (380 - 2760)	11.24 (2.16 - 12.80)	54
		16	13	07	—	—	3.67	3.33	1.80	—	—	8.8 (2.0 - 10.6)	2400 (380 - 2780)	11.48 (2.16 - 12.89)	54
		18	13	07	—	—	3.85	3.21	1.73	—	—	8.8 (2.0 - 10.6)	2400 (380 - 2780)	11.48 (2.16 - 12.89)	54
		16	16	07	—	—	3.57	3.57	1.75	—	—	8.9 (2.0 - 10.7)	2450 (380 - 2790)	11.72 (2.16 - 12.94)	54
		18	16	07	—	—	3.76	3.45	1.69	—	—	8.9 (2.0 - 10.7)	2450 (380 - 2790)	11.72 (2.16 - 12.94)	54
		18	18	07	—	—	3.63	3.63	1.63	—	—	8.9 (2.0 - 10.7)	2450 (380 - 2790)	11.72 (2.16 - 12.94)	54
		10	10	10	—	—	2.87	2.87	2.87	—	—	8.6 (2.0 - 10.4)	2300 (380 - 2750)	11.00 (2.16 - 12.76)	54
		13	10	10	—	—	3.35	2.68	2.68	—	—	8.7 (2.0 - 10.5)	2350 (380 - 2760)	11.24 (2.16 - 12.80)	54
		16	10	10	—	—	3.54	2.58	2.58	—	—	8.7 (2.0 - 10.5)	2350 (380 - 2760)	11.24 (2.16 - 12.80)	54
		18	10	10	—	—	3.73	2.49	2.49	—	—	8.7 (2.0 - 10.5)	2350 (380 - 2760)	11.24 (2.16 - 12.80)	54
		13	13	10	—	—	3.11	3.11	2.49	—	—	8.7 (2.0 - 10.5)	2350 (380 - 2760)	11.24 (2.16 - 12.80)	54
		16	13	10	—	—	3.34	3.03	2.43	—	—	8.8 (2.0 - 10.6)	2400 (380 - 2780)	11.48 (2.16 - 12.89)	54
		18	13	10	—	—	3.52	2.93	2.35	—	—	8.8 (2.0 - 10.6)	2400 (380 - 2780)	11.48 (2.16 - 12.89)	54
		16	16	10	—	—	3.26	3.26	2.37	—	—	8.9 (2.0 - 10.7)	2450 (380 - 2790)	11.72 (2.16 - 12.94)	54
		18	16	10	—	—	3.45	3.16	2.30	—	—	8.9 (2.0 - 10.7)	2450 (380-2790)	11.72 (2.16 - 12.94)	54
		18	18	10	—	—	3.34	3.34	2.23	—	—	8.9 (2.0 - 10.7)	2450 (380 - 2790)	11.72 (2.16 - 12.94)	54
13		13	13	—	—	2.93	2.93	2.93	—	—	8.8 (2.0 - 10.6)	2400 (380 - 2780)	11.48 (2.16 - 12.89)	54	
16		13	13	—	—	3.16	2.87	2.87	—	—	8.9 (2.0 - 10.7)	2450 (380 - 2790)	11.72 (2.16 - 12.94)	54	
18		13	13	—	—	3.34	2.78	2.78	—	—	8.9 (2.0 - 10.7)	2450 (380 - 2790)	11.72 (2.16 - 12.94)	54	
16		16	13	—	—	3.06	3.06	2.78	—	—	8.9 (2.0 - 10.7)	2450 (380 - 2790)	11.72 (2.16 - 12.94)	54	
18		16	13	—	—	3.24	2.97	2.70	—	—	8.9 (2.0 - 10.7)	2450 (380 - 2790)	11.72 (2.16 - 12.94)	54	
18	18	13	—	—	3.14	3.14	2.62	—	—	8.9 (2.0 - 10.7)	2450 (380 - 2790)	11.72 (2.16 - 12.94)	54		

• The above specification values are those under the conditions that the indoor DB/WB=20/—°C and the outdoor DB/WB=7/6°C.

<Heating/220V> (Continued)

Power supply (V)	Operating status	Indoor unit					Unit Capacity					Total			Outdoor noise (dB)
		A	B	C	D	E	A	B	C	D	E	Heating capacity (kW)	Power consumption (W)	Operating current (A)	
220	4 units	07	07	07	07	—	2.20	2.20	2.20	2.20	—	8.8 (2.2 - 10.8)	2100 (450 - 2810)	10.05 (2.56 - 13.03)	54
		10	07	07	07	—	2.91	1.96	1.96	1.96	—	8.8 (2.2 - 10.8)	2100 (450 - 2810)	10.05 (2.56 - 13.03)	54
		13	07	07	07	—	3.36	1.81	1.81	1.81	—	8.8 (2.2 - 10.9)	2100 (460 - 2830)	10.05 (2.61 - 13.13)	54
		16	07	07	07	—	3.64	1.79	1.79	1.79	—	9.0 (2.2 - 10.9)	2250 (460 - 2830)	10.77 (2.61 - 13.13)	54
		18	07	07	07	—	3.83	1.72	1.72	1.72	—	9.0 (2.2 - 10.9)	2250 (460 - 2830)	10.77 (2.61 - 13.13)	54
		10	10	07	07	—	2.63	2.63	1.77	1.77	—	8.8 (2.2 - 10.8)	2100 (450 - 2810)	10.05 (2.56 - 13.03)	54
		13	10	07	07	—	3.09	2.47	1.67	1.67	—	8.9 (2.2 - 10.9)	2100 (460 - 2830)	10.05 (2.61 - 13.13)	54
		16	10	07	07	—	3.32	2.42	1.63	1.63	—	9.0 (2.2 - 10.9)	2250 (460 - 2830)	10.77 (2.61 - 13.13)	54
		18	10	07	07	—	3.51	2.34	1.58	1.58	—	9.0 (2.2 - 10.9)	2250 (460 - 2830)	10.77 (2.61 - 13.13)	54
		13	13	07	07	—	2.92	2.92	1.58	1.58	—	9.0 (2.2 - 10.9)	2250 (470 - 2830)	10.77 (2.67 - 13.13)	54
		16	13	07	07	—	3.11	2.83	1.53	1.53	—	9.0 (2.2 - 11.0)	2250 (480 - 2850)	10.77 (2.73 - 13.22)	54
		18	13	07	07	—	3.29	2.74	1.48	1.48	—	9.0 (2.2 - 11.0)	2250 (490 - 2850)	10.77 (2.78 - 13.22)	54
		16	16	07	07	—	3.02	3.02	1.48	1.48	—	9.0 (2.2 - 11.0)	2250 (500 - 2850)	10.77 (2.84 - 13.22)	54
		18	16	07	07	—	3.20	2.93	1.44	1.44	—	9.0 (2.2 - 11.0)	2250 (500 - 2850)	10.77 (2.84 - 13.22)	54
		18	18	07	07	—	3.10	3.10	1.40	1.40	—	9.0 (2.2 - 11.0)	2250 (490 - 2850)	10.77 (2.78 - 13.22)	54
		10	10	10	07	—	2.39	2.39	2.39	1.62	—	8.8 (2.2 - 10.8)	2100 (450 - 2810)	10.05 (2.56 - 13.03)	54
		13	10	10	07	—	2.83	2.27	2.27	1.53	—	8.9 (2.2 - 10.9)	2100 (460 - 2830)	10.05 (2.61 - 13.13)	54
		16	10	10	07	—	3.06	2.22	2.22	1.50	—	9.0 (2.2 - 10.9)	2250 (460 - 2830)	10.77 (2.61 - 13.13)	54
		18	10	10	07	—	3.23	2.16	2.16	1.46	—	9.0 (2.2 - 10.9)	2250 (460 - 2830)	10.77 (2.61 - 13.13)	54
		13	13	10	07	—	2.69	2.69	2.16	1.46	—	9.0 (2.2 - 10.9)	2250 (470 - 2830)	10.77 (2.67 - 13.13)	54
		16	13	10	07	—	2.88	2.62	2.09	1.41	—	9.0 (2.2 - 11.0)	2250 (480 - 2850)	10.77 (2.73 - 13.22)	54
		18	13	10	07	—	3.05	2.54	2.03	1.37	—	9.0 (2.2 - 11.0)	2250 (490 - 2850)	10.77 (2.78 - 13.22)	54
		16	16	10	07	—	2.80	2.80	2.03	1.37	—	9.0 (2.2 - 11.0)	2250 (500 - 2850)	10.77 (2.84 - 13.22)	54
		18	16	10	07	—	2.97	2.72	1.98	1.34	—	9.0 (2.2 - 11.0)	2250 (500 - 2850)	10.77 (2.84 - 13.22)	54
		18	18	10	07	—	2.89	2.89	1.93	1.30	—	9.0 (2.2 - 11.0)	2250 (490 - 2850)	10.77 (2.78 - 13.22)	54
		13	13	13	07	—	2.54	2.54	2.54	1.37	—	9.0 (2.2 - 11.0)	2250 (480 - 2850)	10.77 (2.73 - 13.22)	54
		16	13	13	07	—	2.72	2.47	2.47	1.34	—	9.0 (2.2 - 11.0)	2250 (490 - 2850)	10.77 (2.78 - 13.22)	54
		18	13	13	07	—	2.89	2.41	2.41	1.30	—	9.0 (2.2 - 11.0)	2250 (490 - 2850)	10.77 (2.78 - 13.22)	54
		16	16	13	07	—	2.65	2.65	2.41	1.30	—	9.0 (2.2 - 11.0)	2250 (490 - 2850)	10.77 (2.78 - 13.22)	54
		18	16	13	07	—	2.81	2.58	2.34	1.27	—	9.0 (2.2 - 11.0)	2250 (490 - 2850)	10.77 (2.78 - 13.22)	54
		18	18	13	07	—	2.74	2.74	2.28	1.23	—	9.0 (2.2 - 11.0)	2250 (490 - 2850)	10.77 (2.78 - 13.22)	54
		10	10	10	10	—	2.23	2.23	2.23	2.23	—	8.9 (2.2 - 10.8)	2100 (450 - 2810)	10.05 (2.56 - 13.03)	54
		13	10	10	10	—	2.62	2.09	2.09	2.09	—	8.9 (2.2 - 10.9)	2100 (460 - 2830)	10.05 (2.61 - 13.13)	54
		16	10	10	10	—	2.83	2.06	2.06	2.06	—	9.0 (2.2 - 10.9)	2250 (460 - 2830)	10.77 (2.61 - 13.13)	54
		18	10	10	10	—	3.00	2.00	2.00	2.00	—	9.0 (2.2 - 10.9)	2250 (460 - 2830)	10.77 (2.61 - 13.13)	54
		13	13	10	10	—	2.50	2.50	2.00	2.00	—	9.0 (2.2 - 10.9)	2250 (470 - 2830)	10.77 (2.67 - 13.13)	54
		16	13	10	10	—	2.68	2.43	1.95	1.95	—	9.0 (2.2 - 11.0)	2250 (480 - 2850)	10.77 (2.73 - 13.22)	54
		16	16	10	10	—	2.61	2.61	1.89	1.89	—	9.0 (2.2 - 11.0)	2250 (500 - 2850)	10.77 (2.84 - 13.22)	54
		18	13	10	10	—	2.84	2.37	1.89	1.89	—	9.0 (2.2 - 11.0)	2250 (490 - 2850)	10.77 (2.78 - 13.22)	54
		18	16	10	10	—	2.77	2.54	1.85	1.85	—	9.0 (2.2 - 11.0)	2250 (490 - 2850)	10.77 (2.78 - 13.22)	54
		18	18	10	10	—	2.70	2.70	1.80	1.80	—	9.0 (2.2 - 11.0)	2250 (490 - 2850)	10.77 (2.78 - 13.22)	54
		13	13	13	10	—	2.37	2.37	2.37	1.89	—	9.0 (2.2 - 11.0)	2250 (480 - 2850)	10.77 (2.73 - 13.22)	54
		16	13	13	10	—	2.54	2.31	2.31	1.85	—	9.0 (2.2 - 11.0)	2250 (490 - 2850)	10.77 (2.78 - 13.22)	54
		16	16	13	10	—	2.48	2.48	2.25	1.80	—	9.0 (2.2 - 11.0)	2250 (490 - 2850)	10.77 (2.78 - 13.22)	54
		18	13	13	10	—	2.70	2.25	2.25	1.80	—	9.0 (2.2 - 11.0)	2250 (490 - 2850)	10.77 (2.78 - 13.22)	54
		18	16	13	10	—	2.63	2.41	2.20	1.76	—	9.0 (2.2 - 11.0)	2250 (490 - 2850)	10.77 (2.78 - 13.22)	54
		18	18	13	10	—	2.57	2.57	2.14	1.71	—	9.0 (2.2 - 11.0)	2250 (490 - 2850)	10.77 (2.78 - 13.22)	54
		13	13	13	13	—	2.25	2.25	2.25	2.25	—	9.0 (2.2 - 11.0)	2250 (490 - 2850)	10.77 (2.78 - 13.22)	54
16	13	13	13	—	2.41	2.20	2.20	2.20	—	9.0 (2.2 - 11.0)	2250 (490 - 2850)	10.77 (2.78 - 13.22)	54		
18	13	13	13	—	2.57	2.14	2.14	2.14	—	9.0 (2.2 - 11.0)	2250 (490 - 2850)	10.77 (2.78 - 13.22)	54		
16	16	13	13	—	2.36	2.36	2.14	2.14	—	9.0 (2.2 - 11.0)	2250 (490 - 2850)	10.77 (2.78 - 13.22)	54		
18	16	13	13	—	2.51	2.30	2.09	2.09	—	9.0 (2.2 - 11.0)	2250 (490 - 2850)	10.77 (2.78 - 13.22)	54		
18	18	13	13	—	2.45	2.45	2.05	2.05	—	9.0 (2.2 - 11.0)	2250 (490 - 2850)	10.77 (2.78 - 13.22)	54		

• The above specification values are those under the conditions that the indoor DB/WB=20/—°C and the outdoor DB/WB=7/6°C.

<Heating/220V> (Continued)

Power supply (V)	Operating status	Indoor unit					Unit Capacity					Total			Outdoor noise (dB)
		A	B	C	D	E	A	B	C	D	E	Heating capacity (kW)	Power consumption (W)	Operating current (A)	
220	5 units	07	07	07	07	07	2.28	2.28	2.28	2.28	2.28	11.4 (3.4 - 13.4)	2690 (775 - 4020)	12.87 (4.40 - 18.65)	54
		10	07	07	07	07	3.16	2.13	2.13	2.13	2.13	11.7 (3.4 - 13.7)	2762 (775 - 4120)	13.22 (4.40 - 19.11)	54
		13	07	07	07	07	3.70	2.00	2.00	2.00	2.00	11.7 (3.4 - 13.7)	2762 (775 - 4120)	13.22 (4.40 - 19.11)	54
		16	07	07	07	07	3.95	1.94	1.94	1.94	1.94	11.7 (3.4 - 13.7)	2762 (775 - 4120)	13.22 (4.40 - 19.11)	54
		18	07	07	07	07	4.18	1.88	1.88	1.88	1.88	11.7 (3.4 - 13.7)	2762 (775 - 4120)	13.22 (4.40 - 19.11)	54
		10	10	07	07	07	2.91	2.91	1.96	1.96	1.96	11.7 (3.4 - 13.7)	2762 (775 - 4120)	13.22 (4.40 - 19.11)	54
		13	10	07	07	07	3.42	2.74	1.85	1.85	1.85	11.7 (3.4 - 13.7)	2762 (775 - 4120)	13.22 (4.40 - 19.11)	54
		16	10	07	07	07	3.66	2.66	1.79	1.79	1.79	11.7 (3.4 - 13.7)	2762 (775 - 4120)	13.22 (4.40 - 19.11)	54
		18	10	07	07	07	3.88	2.59	1.75	1.75	1.75	11.7 (3.4 - 13.7)	2762 (775 - 4120)	13.22 (4.40 - 19.11)	54
		13	13	07	07	07	3.23	3.23	1.75	1.75	1.75	11.7 (3.4 - 13.7)	2762 (775 - 4120)	13.22 (4.40 - 19.11)	54
		16	13	07	07	07	3.46	3.15	1.70	1.70	1.70	11.7 (3.4 - 13.7)	2762 (775 - 4120)	13.22 (4.40 - 19.11)	54
		18	13	07	07	07	3.68	3.06	1.65	1.65	1.65	11.7 (3.4 - 13.7)	2762 (775 - 4120)	13.22 (4.40 - 19.11)	54
		16	16	07	07	07	3.37	3.37	1.65	1.65	1.65	11.7 (3.4 - 13.7)	2762 (775 - 4120)	13.22 (4.40 - 19.11)	54
		18	16	07	07	07	3.58	3.28	1.61	1.61	1.61	11.7 (3.4 - 13.7)	2762 (775 - 4120)	13.22 (4.40 - 19.11)	54
		10	10	10	07	07	2.69	2.69	2.69	1.82	1.82	11.7 (3.4 - 13.7)	2762 (775 - 4120)	13.22 (4.40 - 19.11)	54
		13	10	10	07	07	3.18	2.54	2.54	1.72	1.72	11.7 (3.4 - 13.7)	2762 (775 - 4120)	13.22 (4.40 - 19.11)	54
		13	13	10	07	07	3.02	3.02	2.41	1.63	1.63	11.7 (3.4 - 13.7)	2762 (775 - 4120)	13.22 (4.40 - 19.11)	54
		16	10	10	07	07	3.40	2.48	2.48	1.67	1.67	11.7 (3.4 - 13.7)	2762 (775 - 4120)	13.22 (4.40 - 19.11)	54
		18	10	10	07	07	3.62	2.41	2.41	1.63	1.63	11.7 (3.4 - 13.7)	2762 (775 - 4120)	13.22 (4.40 - 19.11)	54
		13	13	13	07	07	2.87	2.87	2.87	1.55	1.55	11.7 (3.4 - 13.7)	2762 (775 - 4120)	13.22 (4.40 - 19.11)	54
		16	13	13	07	07	3.08	2.80	2.80	1.51	1.51	11.7 (3.4 - 13.7)	2762 (775 - 4120)	13.22 (4.40 - 19.11)	54
		18	13	13	07	07	3.28	2.73	2.73	1.48	1.48	11.7 (3.4 - 13.7)	2762 (775 - 4120)	13.22 (4.40 - 19.11)	54
		16	16	10	07	07	3.15	3.15	2.29	1.55	1.55	11.7 (3.4 - 13.7)	2762 (775 - 4120)	13.22 (4.40 - 19.11)	54
		18	16	10	07	07	3.36	3.08	2.24	1.51	1.51	11.7 (3.4 - 13.7)	2762 (775 - 4120)	13.22 (4.40 - 19.11)	54
		16	16	13	07	07	3.01	3.01	2.73	1.48	1.48	11.7 (3.4 - 13.7)	2762 (775 - 4120)	13.22 (4.40 - 19.11)	54
		18	16	13	07	07	3.21	2.94	2.67	1.44	1.44	11.7 (3.4 - 13.7)	2762 (775 - 4120)	13.22 (4.40 - 19.11)	54
		10	10	10	10	07	2.50	2.50	2.50	2.50	2.50	11.7 (3.4 - 13.7)	2762 (775 - 4120)	13.22 (4.40 - 19.11)	54
		13	10	10	10	07	2.97	2.38	2.38	2.38	2.38	11.7 (3.4 - 13.7)	2762 (775 - 4120)	13.22 (4.40 - 19.11)	54
		16	10	10	10	07	3.19	2.32	2.32	2.32	2.32	11.7 (3.4 - 13.7)	2762 (775 - 4120)	13.22 (4.40 - 19.11)	54
		13	13	10	10	07	2.83	2.83	2.26	2.26	2.26	11.7 (3.4 - 13.7)	2762 (775 - 4120)	13.22 (4.40 - 19.11)	54
		16	13	10	10	07	3.04	2.76	2.21	2.21	2.21	11.7 (3.4 - 13.7)	2762 (775 - 4120)	13.22 (4.40 - 19.11)	54
		16	16	10	10	07	2.97	2.97	2.16	2.16	2.16	11.7 (3.4 - 13.7)	2762 (775 - 4120)	13.22 (4.40 - 19.11)	54
		13	13	13	10	07	2.70	2.70	2.70	2.16	2.16	11.7 (3.4 - 13.7)	2762 (775 - 4120)	13.22 (4.40 - 19.11)	54
		16	13	13	10	07	2.90	2.64	2.64	2.11	2.11	11.7 (3.4 - 13.7)	2762 (775 - 4120)	13.22 (4.40 - 19.11)	54
		16	16	13	10	07	2.83	2.83	2.58	2.06	2.06	11.7 (3.4 - 13.7)	2762 (775 - 4120)	13.22 (4.40 - 19.11)	54
		13	13	13	13	07	2.58	2.58	2.58	2.58	2.58	11.7 (3.4 - 13.7)	2762 (775 - 4120)	13.22 (4.40 - 19.11)	54
		16	13	13	13	07	2.77	2.52	2.52	2.52	2.52	11.7 (3.4 - 13.7)	2762 (775 - 4120)	13.22 (4.40 - 19.11)	54
		16	16	13	13	07	2.72	2.72	2.47	2.47	2.47	11.7 (3.4 - 13.7)	2762 (775 - 4120)	13.22 (4.40 - 19.11)	54
		10	10	10	10	10	2.34	2.34	2.34	2.34	2.34	11.7 (3.4 - 13.7)	2762 (775 - 4120)	13.22 (4.40 - 19.11)	54
		13	10	10	10	10	2.79	2.23	2.23	2.23	2.23	11.7 (3.4 - 13.7)	2762 (775 - 4120)	13.22 (4.40 - 19.11)	54
16	10	10	10	10	2.99	2.18	2.18	2.18	2.18	11.7 (3.4 - 13.7)	2762 (775 - 4120)	13.22 (4.40 - 19.11)	54		
18	10	10	10	10	3.19	2.13	2.13	2.13	2.13	11.7 (3.4 - 13.7)	2762 (775 - 4120)	13.22 (4.40 - 19.11)	54		
13	13	10	10	10	2.66	2.66	2.13	2.13	2.13	11.7 (3.4 - 13.7)	2762 (775 - 4120)	13.22 (4.40 - 19.11)	54		
16	13	10	10	10	2.86	2.60	2.08	2.08	2.08	11.7 (3.4 - 13.7)	2762 (775 - 4120)	13.22 (4.40 - 19.11)	54		
18	13	10	10	10	3.05	2.54	2.03	2.03	2.03	11.7 (3.4 - 13.7)	2762 (775 - 4120)	13.22 (4.40 - 19.11)	54		
16	16	10	10	10	2.80	2.80	2.03	2.03	2.03	11.7 (3.4 - 13.7)	2762 (775 - 4120)	13.22 (4.40 - 19.11)	54		
13	13	13	10	10	2.54	2.54	2.54	2.03	2.03	11.7 (3.4 - 13.7)	2762 (775 - 4120)	13.22 (4.40 - 19.11)	54		
16	13	13	10	10	2.74	2.49	2.49	1.99	1.99	11.7 (3.4 - 13.7)	2762 (775 - 4120)	13.22 (4.40 - 19.11)	54		
18	13	13	10	10	2.93	2.44	2.44	1.95	1.95	11.7 (3.4 - 13.7)	2762 (775 - 4120)	13.22 (4.40 - 19.11)	54		
16	16	13	10	10	2.75	2.75	2.50	2.00	2.00	12.0 (3.4 - 14.0)	2833 (775 - 4200)	13.56 (4.40 - 19.48)	54		
13	13	13	13	10	2.44	2.44	2.44	2.44	2.44	11.7 (3.4 - 13.7)	2762 (775 - 4120)	13.22 (4.40 - 19.11)	54		
16	13	13	13	10	2.69	2.45	2.45	2.45	2.45	12.0 (3.4 - 14.0)	2833 (775 - 4200)	13.56 (4.40 - 19.48)	54		
18	13	13	13	10	2.88	2.40	2.40	2.40	2.40	12.0 (3.4 - 14.0)	2833 (775 - 4200)	13.56 (4.40 - 19.48)	54		
16	16	13	13	10	2.64	2.64	2.40	2.40	2.40	12.0 (3.4 - 14.0)	2833 (775 - 4200)	13.56 (4.40 - 19.48)	54		
13	13	13	13	13	2.40	2.40	2.40	2.40	2.40	12.0 (3.4 - 14.0)	2833 (775 - 4200)	13.56 (4.40 - 19.48)	54		
16	13	13	13	13	2.59	2.35	2.35	2.35	2.35	12.0 (3.4 - 14.0)	2833 (775 - 4200)	13.56 (4.40 - 19.48)	54		

• The above specification values are those under the conditions that the indoor DB/WB=20/—°C and the outdoor DB/WB=7/6°C.

# Outdoor Unit : RAS-5M34UAV-E

## <Heating/230V>

Power supply (V)	Operating status	Indoor unit					Unit Capacity					Total			Outdoor noise (dB)
		A	B	C	D	E	A	B	C	D	E	Heating capacity (kW)	Power consumption (W)	Operating current (A)	
230	1 unit	07	—	—	—	—	2.7	—	—	—	—	2.7 (0.8 - 3.7)	900 (300 - 1340)	4.50 (1.79 - 5.94)	54
		10	—	—	—	—	4.0	—	—	—	—	4.0 (0.8 - 5.2)	1450 (300 - 1980)	6.64 (1.79 - 8.78)	54
		13	—	—	—	—	5.0	—	—	—	—	5.0 (0.8 - 6.5)	2050 (310 - 2750)	9.38 (1.85 - 12.20)	54
		16	—	—	—	—	5.5	—	—	—	—	5.5 (0.8 - 6.9)	2400 (310 - 3000)	10.98 (1.85 - 13.31)	54
		18	—	—	—	—	6.0	—	—	—	—	6.0 (0.8 - 7.1)	2630 (310 - 3200)	12.04 (1.85 - 14.20)	54
	2 units	07	07	—	—	—	2.70	2.70	—	—	—	5.4 (1.5 - 7.4)	2050 (320 - 3200)	9.38 (1.86 - 14.20)	54
		10	07	—	—	—	4.00	2.70	—	—	—	6.7 (1.5 - 8.9)	2080 (320 - 3200)	9.52 (1.86 - 14.20)	54
		13	07	—	—	—	4.81	2.59	—	—	—	7.4 (1.5 - 10.1)	2320 (320 - 3210)	10.62 (1.86 - 14.24)	54
		16	07	—	—	—	5.10	2.50	—	—	—	7.6 (1.5 - 10.1)	2480 (320 - 3230)	11.35 (1.86 - 14.33)	54
		18	07	—	—	—	5.45	2.45	—	—	—	7.9 (1.5 - 10.1)	2480 (320 - 3230)	11.35 (1.86 - 14.33)	54
		10	10	—	—	—	3.60	3.60	—	—	—	7.2 (1.5 - 10.0)	2100 (320 - 3200)	9.61 (1.86 - 14.20)	54
		13	10	—	—	—	4.22	3.38	—	—	—	7.6 (1.5 - 10.1)	2320 (320 - 3210)	10.62 (1.86 - 14.24)	54
		16	10	—	—	—	4.57	3.33	—	—	—	7.9 (1.5 - 10.1)	2480 (320 - 3230)	11.35 (1.86 - 14.33)	54
		18	10	—	—	—	4.74	3.16	—	—	—	7.9 (1.5 - 10.1)	2480 (320 - 3230)	11.35 (1.86 - 14.33)	54
		13	13	—	—	—	3.95	3.95	—	—	—	7.9 (1.5 - 10.1)	2480 (320 - 3230)	11.35 (1.86 - 14.33)	54
		16	13	—	—	—	4.35	3.95	—	—	—	8.3 (1.5 - 10.2)	2700 (320 - 3240)	12.36 (1.86 - 14.37)	54
		18	13	—	—	—	4.53	3.77	—	—	—	8.3 (1.5 - 10.2)	2700 (320 - 3240)	12.36 (1.86 - 14.37)	54
		16	16	—	—	—	4.30	4.30	—	—	—	8.6 (1.5 - 10.2)	2860 (320 - 3250)	13.09 (1.86 - 14.42)	54
		18	16	—	—	—	4.49	4.11	—	—	—	8.6 (1.5 - 10.2)	2860 (320 - 3250)	13.09 (1.86 - 14.42)	54
		18	18	—	—	—	4.30	4.30	—	—	—	8.6 (1.5 - 10.2)	2860 (320 - 3250)	13.09 (1.86 - 14.42)	54
	3 units	07	07	07	—	—	2.70	2.70	2.70	—	—	8.1 (2.0 - 10.4)	2290 (380 - 2750)	10.48 (2.07 - 12.20)	54
		10	07	07	—	—	3.53	2.38	2.38	—	—	8.3 (2.0 - 10.4)	2300 (380 - 2750)	10.53 (2.07 - 12.20)	54
		13	07	07	—	—	4.13	2.23	2.23	—	—	8.6 (2.0 - 10.4)	2300 (380 - 2750)	10.53 (2.07 - 12.20)	54
		16	07	07	—	—	4.39	2.16	2.16	—	—	8.7 (2.0 - 10.5)	2350 (380 - 2760)	10.76 (2.07 - 12.24)	54
		18	07	07	—	—	4.58	2.06	2.06	—	—	8.7 (2.0 - 10.5)	2350 (380 - 2760)	10.76 (2.07 - 12.24)	54
		10	10	07	—	—	3.18	3.18	2.14	—	—	8.5 (2.0 - 10.4)	2300 (380 - 2750)	10.53 (2.07 - 12.20)	54
		13	10	07	—	—	3.72	2.97	2.01	—	—	8.7 (2.0 - 10.5)	2350 (380 - 2760)	10.76 (2.07 - 12.24)	54
		16	10	07	—	—	3.92	2.85	1.93	—	—	8.7 (2.0 - 10.5)	2350 (380 - 2760)	10.76 (2.07 - 12.24)	54
		18	10	07	—	—	4.11	2.74	1.85	—	—	8.7 (2.0 - 10.5)	2350 (380 - 2760)	10.76 (2.07 - 12.24)	54
		13	13	07	—	—	3.43	3.43	1.85	—	—	8.7 (2.0 - 10.5)	2350 (380 - 2760)	10.76 (2.07 - 12.24)	54
		16	13	07	—	—	3.67	3.33	1.80	—	—	8.8 (2.0 - 10.6)	2400 (380 - 2780)	10.98 (2.07 - 12.33)	54
		18	13	07	—	—	3.85	3.21	1.73	—	—	8.8 (2.0 - 10.6)	2400 (380 - 2780)	10.98 (2.07 - 12.33)	54
		16	16	07	—	—	3.57	3.57	1.75	—	—	8.9 (2.0 - 10.7)	2450 (380 - 2790)	11.21 (2.07 - 12.38)	54
		18	16	07	—	—	3.76	3.45	1.69	—	—	8.9 (2.0 - 10.7)	2450 (380 - 2790)	11.21 (2.07 - 12.38)	54
		18	18	07	—	—	3.63	3.63	1.63	—	—	8.9 (2.0 - 10.7)	2450 (380 - 2790)	11.21 (2.07 - 12.38)	54
		10	10	10	—	—	2.87	2.87	2.87	—	—	8.6 (2.0 - 10.4)	2300 (380 - 2750)	10.53 (2.07 - 12.20)	54
		13	10	10	—	—	3.35	2.68	2.68	—	—	8.7 (2.0 - 10.5)	2350 (380 - 2760)	10.76 (2.07 - 12.24)	54
		16	10	10	—	—	3.54	2.58	2.58	—	—	8.7 (2.0 - 10.5)	2350 (380 - 2760)	10.76 (2.07 - 12.24)	54
		18	10	10	—	—	3.73	2.49	2.49	—	—	8.7 (2.0 - 10.5)	2350 (380 - 2760)	10.76 (2.07 - 12.24)	54
		13	13	10	—	—	3.11	3.11	2.49	—	—	8.7 (2.0 - 10.5)	2350 (380 - 2760)	10.76 (2.07 - 12.24)	54
		16	13	10	—	—	3.34	3.03	2.43	—	—	8.8 (2.0 - 10.6)	2400 (380 - 2780)	10.98 (2.07 - 12.33)	54
		18	13	10	—	—	3.52	2.93	2.35	—	—	8.8 (2.0 - 10.6)	2400 (380 - 2780)	10.98 (2.07 - 12.33)	54
		16	16	10	—	—	3.26	3.26	2.37	—	—	8.9 (2.0 - 10.7)	2450 (380 - 2790)	11.21 (2.07 - 12.38)	54
		18	16	10	—	—	3.45	3.16	2.30	—	—	8.9 (2.0 - 10.7)	2450 (380 - 2790)	11.21 (2.07 - 12.38)	54
		18	18	10	—	—	3.34	3.34	2.23	—	—	8.9 (2.0 - 10.7)	2450 (380 - 2790)	11.21 (2.07 - 12.38)	54
13		13	13	—	—	2.93	2.93	2.93	—	—	8.8 (2.0 - 10.6)	2400 (380 - 2780)	10.98 (2.07 - 12.33)	54	
16		13	13	—	—	3.16	2.87	2.87	—	—	8.9 (2.0 - 10.7)	2450 (380 - 2790)	11.21 (2.07 - 12.38)	54	
18		13	13	—	—	3.34	2.78	2.78	—	—	8.9 (2.0 - 10.7)	2450 (380 - 2790)	11.21 (2.07 - 12.38)	54	
16		16	13	—	—	3.06	3.06	2.78	—	—	8.9 (2.0 - 10.7)	2450 (380 - 2790)	11.21 (2.07 - 12.38)	54	
18		16	13	—	—	3.24	2.97	2.70	—	—	8.9 (2.0 - 10.7)	2450 (380 - 2790)	11.21 (2.07 - 12.38)	54	
18		18	13	—	—	3.14	3.14	2.62	—	—	8.9 (2.0 - 10.7)	2450 (380 - 2790)	11.21 (2.07 - 12.38)	54	

• The above specification values are those under the conditions that the indoor DB/WB=20/—°C and the outdoor DB/WB=7/6°C.



<Heating/230V> (Continued)

Power supply (V)	Operating status	Indoor unit					Unit Capacity					Total			Outdoor noise (dB)
		A	B	C	D	E	A	B	C	D	E	Heating capacity (kW)	Power consumption (W)	Operating current (A)	
230	4 units	07	07	07	07	—	2.20	2.20	2.20	2.20	—	8.8 (2.2 - 10.8)	2100 (450 - 2810)	9.61 (2.45 - 12.47)	54
		10	07	07	07	—	2.91	1.96	1.96	1.96	—	8.8 (2.2 - 10.8)	2100 (450 - 2810)	9.61 (2.45 - 12.47)	54
		13	07	07	07	—	3.36	1.81	1.81	1.81	—	8.8 (2.2 - 10.9)	2100 (460 - 2830)	9.61 (2.50 - 12.56)	54
		16	07	07	07	—	3.64	1.79	1.79	1.79	—	9.0 (2.2 - 10.9)	2250 (460 - 2830)	10.30 (2.50 - 12.56)	54
		18	07	07	07	—	3.83	1.72	1.72	1.72	—	9.0 (2.2 - 10.9)	2250 (460 - 2830)	10.30 (2.50 - 12.56)	54
		10	10	07	07	—	2.63	2.63	1.77	1.77	—	8.8 (2.2 - 10.8)	2100 (450 - 2810)	9.61 (2.45 - 12.47)	54
		13	10	07	07	—	3.09	2.47	1.67	1.67	—	8.9 (2.2 - 10.9)	2100 (460 - 2830)	9.61 (2.50 - 12.56)	54
		16	10	07	07	—	3.32	2.42	1.63	1.63	—	9.0 (2.2 - 10.9)	2250 (460 - 2830)	10.30 (2.50 - 12.56)	54
		18	10	07	07	—	3.51	2.34	1.58	1.58	—	9.0 (2.2 - 10.9)	2250 (460 - 2830)	10.30 (2.50 - 12.56)	54
		13	13	07	07	—	2.92	2.92	1.58	1.58	—	9.0 (2.2 - 10.9)	2250 (470 - 2830)	10.30 (2.55 - 12.56)	54
		16	13	07	07	—	3.11	2.83	1.53	1.53	—	9.0 (2.2 - 11.0)	2250 (480 - 2850)	10.30 (2.61 - 12.64)	54
		18	13	07	07	—	3.29	2.74	1.48	1.48	—	9.0 (2.2 - 11.0)	2250 (490 - 2850)	10.30 (2.66 - 12.64)	54
		16	16	07	07	—	3.02	3.02	1.48	1.48	—	9.0 (2.2 - 11.0)	2250 (500 - 2850)	10.30 (2.72 - 12.64)	54
		18	16	07	07	—	3.20	2.93	1.44	1.44	—	9.0 (2.2 - 11.0)	2250 (500 - 2850)	10.30 (2.72 - 12.64)	54
		18	18	07	07	—	3.10	3.10	1.40	1.40	—	9.0 (2.2 - 11.0)	2250 (490 - 2850)	10.30 (2.66 - 12.64)	54
		10	10	10	07	—	2.39	2.39	2.39	1.62	—	8.8 (2.2 - 10.8)	2100 (450 - 2810)	9.61 (2.45 - 12.47)	54
		13	10	10	07	—	2.83	2.27	2.27	1.53	—	8.9 (2.2 - 10.9)	2100 (460 - 2830)	9.61 (2.50 - 12.56)	54
		16	10	10	07	—	3.06	2.22	2.22	1.50	—	9.0 (2.2 - 10.9)	2250 (460 - 2830)	10.30 (2.50 - 12.56)	54
		18	10	10	07	—	3.23	2.16	2.16	1.46	—	9.0 (2.2 - 10.9)	2250 (460 - 2830)	10.30 (2.50 - 12.56)	54
		13	13	10	07	—	2.69	2.69	2.16	1.46	—	9.0 (2.2 - 10.9)	2250 (470 - 2830)	10.30 (2.55 - 12.56)	54
		16	13	10	07	—	2.88	2.62	2.09	1.41	—	9.0 (2.2 - 11.0)	2250 (480 - 2850)	10.30 (2.61 - 12.64)	54
		18	13	10	07	—	3.05	2.54	2.03	1.37	—	9.0 (2.2 - 11.0)	2250 (490 - 2850)	10.30 (2.66 - 12.64)	54
		16	16	10	07	—	2.80	2.80	2.03	1.37	—	9.0 (2.2 - 11.0)	2250 (500 - 2850)	10.30 (2.72 - 12.64)	54
		18	16	10	07	—	2.97	2.72	1.98	1.34	—	9.0 (2.2 - 11.0)	2250 (500 - 2850)	10.30 (2.72 - 12.64)	54
		18	18	10	07	—	2.89	2.89	1.93	1.30	—	9.0 (2.2 - 11.0)	2250 (490 - 2850)	10.30 (2.66 - 12.64)	54
		13	13	13	07	—	2.54	2.54	2.54	1.37	—	9.0 (2.2 - 11.0)	2250 (480 - 2850)	10.30 (2.61 - 12.64)	54
		16	13	13	07	—	2.72	2.47	2.47	1.34	—	9.0 (2.2 - 11.0)	2250 (490 - 2850)	10.30 (2.66 - 12.64)	54
		18	13	13	07	—	2.89	2.41	2.41	1.30	—	9.0 (2.2 - 11.0)	2250 (490 - 2850)	10.30 (2.66 - 12.64)	54
		16	16	13	07	—	2.65	2.65	2.41	1.30	—	9.0 (2.2 - 11.0)	2250 (490 - 2850)	10.30 (2.66 - 12.64)	54
		18	16	13	07	—	2.81	2.58	2.34	1.27	—	9.0 (2.2 - 11.0)	2250 (490 - 2850)	10.30 (2.66 - 12.64)	54
		18	18	13	07	—	2.74	2.74	2.28	1.23	—	9.0 (2.2 - 11.0)	2250 (490 - 2850)	10.30 (2.66 - 12.64)	54
		10	10	10	10	—	2.23	2.23	2.23	2.23	—	8.9 (2.2 - 10.8)	2100 (450 - 2810)	9.61 (2.45 - 12.47)	54
		13	10	10	10	—	2.62	2.09	2.09	2.09	—	8.9 (2.2 - 10.9)	2100 (460 - 2830)	9.61 (2.50 - 12.56)	54
		16	10	10	10	—	2.83	2.06	2.06	2.06	—	9.0 (2.2 - 10.9)	2250 (460 - 2830)	10.30 (2.50 - 12.56)	54
		18	10	10	10	—	3.00	2.00	2.00	2.00	—	9.0 (2.2 - 10.9)	2250 (460 - 2830)	10.30 (2.50 - 12.56)	54
		13	13	10	10	—	2.50	2.50	2.00	2.00	—	9.0 (2.2 - 10.9)	2250 (470 - 2830)	10.30 (2.55 - 12.56)	54
		16	13	10	10	—	2.68	2.43	1.95	1.95	—	9.0 (2.2 - 11.0)	2250 (480 - 2850)	10.30 (2.61 - 12.64)	54
		16	16	10	10	—	2.61	2.61	1.89	1.89	—	9.0 (2.2 - 11.0)	2250 (500 - 2850)	10.30 (2.72 - 12.64)	54
		18	13	10	10	—	2.84	2.37	1.89	1.89	—	9.0 (2.2 - 11.0)	2250 (490 - 2850)	10.30 (2.66 - 12.64)	54
		18	16	10	10	—	2.77	2.54	1.85	1.85	—	9.0 (2.2 - 11.0)	2250 (490 - 2850)	10.30 (2.66 - 12.64)	54
		18	18	10	10	—	2.70	2.70	1.80	1.80	—	9.0 (2.2 - 11.0)	2250 (490 - 2850)	10.30 (2.66 - 12.64)	54
		13	13	13	10	—	2.37	2.37	2.37	1.89	—	9.0 (2.2 - 11.0)	2250 (480 - 2850)	10.30 (2.61 - 12.64)	54
		16	13	13	10	—	2.54	2.31	2.31	1.85	—	9.0 (2.2 - 11.0)	2250 (490 - 2850)	10.30 (2.66 - 12.64)	54
		16	16	13	10	—	2.48	2.48	2.25	1.80	—	9.0 (2.2 - 11.0)	2250 (490 - 2850)	10.30 (2.66 - 12.64)	54
		18	13	13	10	—	2.70	2.25	2.25	1.80	—	9.0 (2.2 - 11.0)	2250 (490 - 2850)	10.30 (2.66 - 12.64)	54
		18	16	13	10	—	2.63	2.41	2.20	1.76	—	9.0 (2.2 - 11.0)	2250 (490 - 2850)	10.30 (2.66 - 12.64)	54
		18	18	13	10	—	2.57	2.57	2.14	1.71	—	9.0 (2.2 - 11.0)	2250 (490 - 2850)	10.30 (2.66 - 12.64)	54
		13	13	13	13	—	2.25	2.25	2.25	2.25	—	9.0 (2.2 - 11.0)	2250 (490 - 2850)	10.30 (2.66 - 12.64)	54
16	13	13	13	—	2.41	2.20	2.20	2.20	—	9.0 (2.2 - 11.0)	2250 (490 - 2850)	10.30 (2.66 - 12.64)	54		
18	13	13	13	—	2.57	2.14	2.14	2.14	—	9.0 (2.2 - 11.0)	2250 (490 - 2850)	10.30 (2.66 - 12.64)	54		
16	16	13	13	—	2.36	2.36	2.14	2.14	—	9.0 (2.2 - 11.0)	2250 (490 - 2850)	10.30 (2.66 - 12.64)	54		
18	16	13	13	—	2.51	2.30	2.09	2.09	—	9.0 (2.2 - 11.0)	2250 (490 - 2850)	10.30 (2.66 - 12.64)	54		
18	18	13	13	—	2.45	2.45	2.05	2.05	—	9.0 (2.2 - 11.0)	2250 (490 - 2850)	10.30 (2.66 - 12.64)	54		

• The above specification values are those under the conditions that the indoor DB/WB=20/—°C and the outdoor DB/WB=7/6°C.



<Heating/230V> (Continued)

Power supply (V)	Operating status	Indoor unit					Unit Capacity					Total			Outdoor noise (dB)
		A	B	C	D	E	A	B	C	D	E	Heating capacity (kW)	Power consumption (W)	Operating current (A)	
230	5 units	07	07	07	07	07	2.28	2.28	2.28	2.28	2.28	11.4 (3.4 - 13.4)	2690 (775 - 4020)	12.31 (4.21 - 17.83)	54
		10	07	07	07	07	3.16	2.13	2.13	2.13	2.13	11.7 (3.4 - 13.7)	2762 (775 - 4120)	12.64 (4.21 - 18.28)	54
		13	07	07	07	07	3.70	2.00	2.00	2.00	2.00	11.7 (3.4 - 13.7)	2762 (775 - 4120)	12.64 (4.21 - 18.28)	54
		16	07	07	07	07	3.95	1.94	1.94	1.94	1.94	11.7 (3.4 - 13.7)	2762 (775 - 4120)	12.64 (4.21 - 18.28)	54
		18	07	07	07	07	4.18	1.88	1.88	1.88	1.88	11.7 (3.4 - 13.7)	2762 (775 - 4120)	12.64 (4.21 - 18.28)	54
		10	10	07	07	07	2.91	2.91	1.96	1.96	1.96	11.7 (3.4 - 13.7)	2762 (775 - 4120)	12.64 (4.21 - 18.28)	54
		13	10	07	07	07	3.42	2.74	1.85	1.85	1.85	11.7 (3.4 - 13.7)	2762 (775 - 4120)	12.64 (4.21 - 18.28)	54
		16	10	07	07	07	3.66	2.66	1.79	1.79	1.79	11.7 (3.4 - 13.7)	2762 (775 - 4120)	12.64 (4.21 - 18.28)	54
		18	10	07	07	07	3.88	2.59	1.75	1.75	1.75	11.7 (3.4 - 13.7)	2762 (775 - 4120)	12.64 (4.21 - 18.28)	54
		13	13	07	07	07	3.23	3.23	1.75	1.75	1.75	11.7 (3.4 - 13.7)	2762 (775 - 4120)	12.64 (4.21 - 18.28)	54
		16	13	07	07	07	3.46	3.15	1.70	1.70	1.70	11.7 (3.4 - 13.7)	2762 (775 - 4120)	12.64 (4.21 - 18.28)	54
		18	13	07	07	07	3.68	3.06	1.65	1.65	1.65	11.7 (3.4 - 13.7)	2762 (775 - 4120)	12.64 (4.21 - 18.28)	54
		16	16	07	07	07	3.37	3.37	1.65	1.65	1.65	11.7 (3.4 - 13.7)	2762 (775 - 4120)	12.64 (4.21 - 18.28)	54
		18	16	07	07	07	3.58	3.28	1.61	1.61	1.61	11.7 (3.4 - 13.7)	2762 (775 - 4120)	12.64 (4.21 - 18.28)	54
		10	10	10	07	07	2.69	2.69	2.69	1.82	1.82	11.7 (3.4 - 13.7)	2762 (775 - 4120)	12.64 (4.21 - 18.28)	54
		13	10	10	07	07	3.18	2.54	2.54	1.72	1.72	11.7 (3.4 - 13.7)	2762 (775 - 4120)	12.64 (4.21 - 18.28)	54
		13	13	10	07	07	3.02	3.02	2.41	1.63	1.63	11.7 (3.4 - 13.7)	2762 (775 - 4120)	12.64 (4.21 - 18.28)	54
		16	10	10	07	07	3.40	2.48	2.48	1.67	1.67	11.7 (3.4 - 13.7)	2762 (775 - 4120)	12.64 (4.21 - 18.28)	54
		18	10	10	07	07	3.62	2.41	2.41	1.63	1.63	11.7 (3.4 - 13.7)	2762 (775 - 4120)	12.64 (4.21 - 18.28)	54
		13	13	13	07	07	2.87	2.87	2.87	1.55	1.55	11.7 (3.4 - 13.7)	2762 (775 - 4120)	12.64 (4.21 - 18.28)	54
		16	13	13	07	07	3.08	2.80	2.80	1.51	1.51	11.7 (3.4 - 13.7)	2762 (775 - 4120)	12.64 (4.21 - 18.28)	54
		18	13	13	07	07	3.28	2.73	2.73	1.48	1.48	11.7 (3.4 - 13.7)	2762 (775 - 4120)	12.64 (4.21 - 18.28)	54
		16	16	10	07	07	3.15	3.15	2.29	1.55	1.55	11.7 (3.4 - 13.7)	2762 (775 - 4120)	12.64 (4.21 - 18.28)	54
		18	16	10	07	07	3.36	3.08	2.24	1.51	1.51	11.7 (3.4 - 13.7)	2762 (775 - 4120)	12.64 (4.21 - 18.28)	54
		16	16	13	07	07	3.01	3.01	2.73	1.48	1.48	11.7 (3.4 - 13.7)	2762 (775 - 4120)	12.64 (4.21 - 18.28)	54
		18	16	13	07	07	3.21	2.94	2.67	1.44	1.44	11.7 (3.4 - 13.7)	2762 (775 - 4120)	12.64 (4.21 - 18.28)	54
		10	10	10	10	07	2.50	2.50	2.50	2.50	2.50	11.7 (3.4 - 13.7)	2762 (775 - 4120)	12.64 (4.21 - 18.28)	54
		13	10	10	10	07	2.97	2.38	2.38	2.38	2.38	11.7 (3.4 - 13.7)	2762 (775 - 4120)	12.64 (4.21 - 18.28)	54
		16	10	10	10	07	3.19	2.32	2.32	2.32	2.32	11.7 (3.4 - 13.7)	2762 (775 - 4120)	12.64 (4.21 - 18.28)	54
		13	13	10	10	07	2.83	2.83	2.26	2.26	2.26	11.7 (3.4 - 13.7)	2762 (775 - 4120)	12.64 (4.21 - 18.28)	54
		16	13	10	10	07	3.04	2.76	2.21	2.21	2.21	11.7 (3.4 - 13.7)	2762 (775 - 4120)	12.64 (4.21 - 18.28)	54
		16	16	10	10	07	2.97	2.97	2.16	2.16	2.16	11.7 (3.4 - 13.7)	2762 (775 - 4120)	12.64 (4.21 - 18.28)	54
		13	13	13	10	07	2.70	2.70	2.70	2.16	2.16	11.7 (3.4 - 13.7)	2762 (775 - 4120)	12.64 (4.21 - 18.28)	54
		16	13	13	10	07	2.90	2.64	2.64	2.11	2.11	11.7 (3.4 - 13.7)	2762 (775 - 4120)	12.64 (4.21 - 18.28)	54
		16	16	13	10	07	2.83	2.83	2.58	2.06	2.06	11.7 (3.4 - 13.7)	2762 (775 - 4120)	12.64 (4.21 - 18.28)	54
		13	13	13	13	07	2.58	2.58	2.58	2.58	2.58	11.7 (3.4 - 13.7)	2762 (775 - 4120)	12.64 (4.21 - 18.28)	54
		16	13	13	13	07	2.77	2.52	2.52	2.52	2.52	11.7 (3.4 - 13.7)	2762 (775 - 4120)	12.64 (4.21 - 18.28)	54
		16	16	13	13	07	2.72	2.72	2.47	2.47	2.47	11.7 (3.4 - 13.7)	2762 (775 - 4120)	12.64 (4.21 - 18.28)	54
		10	10	10	10	10	2.34	2.34	2.34	2.34	2.34	11.7 (3.4 - 13.7)	2762 (775 - 4120)	12.64 (4.21 - 18.28)	54
		13	10	10	10	10	2.79	2.23	2.23	2.23	2.23	11.7 (3.4 - 13.7)	2762 (775 - 4120)	12.64 (4.21 - 18.28)	54
16	10	10	10	10	2.99	2.18	2.18	2.18	2.18	11.7 (3.4 - 13.7)	2762 (775 - 4120)	12.64 (4.21 - 18.28)	54		
18	10	10	10	10	3.19	2.13	2.13	2.13	2.13	11.7 (3.4 - 13.7)	2762 (775 - 4120)	12.64 (4.21 - 18.28)	54		
13	13	10	10	10	2.66	2.66	2.13	2.13	2.13	11.7 (3.4 - 13.7)	2762 (775 - 4120)	12.64 (4.21 - 18.28)	54		
16	13	10	10	10	2.86	2.60	2.08	2.08	2.08	11.7 (3.4 - 13.7)	2762 (775 - 4120)	12.64 (4.21 - 18.28)	54		
18	13	10	10	10	3.05	2.54	2.03	2.03	2.03	11.7 (3.4 - 13.7)	2762 (775 - 4120)	12.64 (4.21 - 18.28)	54		
16	16	10	10	10	2.80	2.80	2.03	2.03	2.03	11.7 (3.4 - 13.7)	2762 (775 - 4120)	12.64 (4.21 - 18.28)	54		
13	13	13	10	10	2.54	2.54	2.54	2.03	2.03	11.7 (3.4 - 13.7)	2762 (775 - 4120)	12.64 (4.21 - 18.28)	54		
16	13	13	10	10	2.74	2.49	2.49	1.99	1.99	11.7 (3.4 - 13.7)	2762 (775 - 4120)	12.64 (4.21 - 18.28)	54		
18	13	13	10	10	2.93	2.44	2.44	1.95	1.95	11.7 (3.4 - 13.7)	2762 (775 - 4120)	12.64 (4.21 - 18.28)	54		
16	16	13	10	10	2.75	2.75	2.50	2.00	2.00	12.0 (3.4 - 14.0)	2833 (775 - 4200)	12.97 (4.21 - 18.63)	54		
13	13	13	13	10	2.44	2.44	2.44	2.44	2.44	11.7 (3.4 - 13.7)	2762 (775 - 4120)	12.64 (4.21 - 18.28)	54		
16	13	13	13	10	2.69	2.45	2.45	2.45	2.45	12.0 (3.4 - 14.0)	2833 (775 - 4200)	12.97 (4.21 - 18.63)	54		
18	13	13	13	10	2.88	2.40	2.40	2.40	2.40	12.0 (3.4 - 14.0)	2833 (775 - 4200)	12.97 (4.21 - 18.63)	54		
16	16	13	13	10	2.64	2.64	2.40	2.40	2.40	12.0 (3.4 - 14.0)	2833 (775 - 4200)	12.97 (4.21 - 18.63)	54		
13	13	13	13	13	2.40	2.40	2.40	2.40	2.40	12.0 (3.4 - 14.0)	2833 (775 - 4200)	12.97 (4.21 - 18.63)	54		
16	13	13	13	13	2.59	2.35	2.35	2.35	2.35	12.0 (3.4 - 14.0)	2833 (775 - 4200)	12.97 (4.21 - 18.63)	54		

• The above specification values are those under the conditions that the indoor DB/WB=20/–°C and the outdoor DB/WB=7/6°C.

# Outdoor Unit : RAS-5M34UAV-E

## <Heating/240V>

Power supply (V)	Operating status	Indoor unit					Unit Capacity					Total			Outdoor noise (dB)
		A	B	C	D	E	A	B	C	D	E	Heating capacity (kW)	Power consumption (W)	Operating current (A)	
240	1 unit	07	—	—	—	—	2.7	—	—	—	—	2.7 (0.8 - 3.7)	900 (300 - 1340)	4.31 (1.71 - 5.70)	54
		10	—	—	—	—	4.0	—	—	—	—	4.0 (0.8 - 5.2)	1450 (300 - 1980)	6.36 (1.71 - 8.42)	54
		13	—	—	—	—	5.0	—	—	—	—	5.0 (0.8 - 6.5)	2050 (310 - 2750)	8.99 (1.77 - 11.69)	54
		16	—	—	—	—	5.5	—	—	—	—	5.5 (0.8 - 6.9)	2400 (310 - 3000)	10.53 (1.77 - 12.76)	54
		18	—	—	—	—	6.0	—	—	—	—	6.0 (0.8 - 7.1)	2630 (310 - 3200)	11.54 (1.77 - 13.61)	54
	2 units	07	07	—	—	—	2.70	2.70	—	—	—	5.4 (1.5 - 7.4)	2050 (320 - 3200)	8.99 (1.78 - 13.61)	54
		10	07	—	—	—	4.00	2.70	—	—	—	6.7 (1.5 - 8.9)	2080 (320 - 3200)	9.12 (1.78 - 13.61)	54
		13	07	—	—	—	4.81	2.59	—	—	—	7.4 (1.5 - 10.1)	2320 (320 - 3210)	10.18 (1.78 - 13.65)	54
		16	07	—	—	—	5.10	2.50	—	—	—	7.6 (1.5 - 10.1)	2480 (320 - 3230)	10.88 (1.78 - 13.73)	54
		18	07	—	—	—	5.45	2.45	—	—	—	7.9 (1.5 - 10.1)	2480 (320 - 3230)	10.88 (1.78 - 13.73)	54
		10	10	—	—	—	3.60	3.60	—	—	—	7.2 (1.5 - 10.0)	2100 (320 - 3200)	9.21 (1.78 - 13.61)	54
		13	10	—	—	—	4.22	3.38	—	—	—	7.6 (1.5 - 10.1)	2320 (320 - 3210)	10.18 (1.78 - 13.65)	54
		16	10	—	—	—	4.57	3.33	—	—	—	7.9 (1.5 - 10.1)	2480 (320 - 3230)	10.88 (1.78 - 13.73)	54
		18	10	—	—	—	4.74	3.16	—	—	—	7.9 (1.5 - 10.1)	2480 (320 - 3230)	10.88 (1.78 - 13.73)	54
		13	13	—	—	—	3.95	3.95	—	—	—	7.9 (1.5 - 10.1)	2480 (320 - 3230)	10.88 (1.78 - 13.73)	54
		16	13	—	—	—	4.35	3.95	—	—	—	8.3 (1.5 - 10.2)	2700 (320 - 3240)	11.84 (1.78 - 13.78)	54
		18	13	—	—	—	4.53	3.77	—	—	—	8.3 (1.5 - 10.2)	2700 (320 - 3240)	11.84 (1.78 - 13.78)	54
		16	16	—	—	—	4.30	4.30	—	—	—	8.6 (1.5 - 10.2)	2860 (320 - 3250)	12.54 (1.78 - 13.82)	54
		18	16	—	—	—	4.49	4.11	—	—	—	8.6 (1.5 - 10.2)	2860 (320 - 3250)	12.54 (1.78 - 13.82)	54
		18	18	—	—	—	4.30	4.30	—	—	—	8.6 (1.5 - 10.2)	2860 (320 - 3250)	12.54 (1.78 - 13.82)	54
	3 units	07	07	07	—	—	2.70	2.70	2.70	—	—	8.1 (2.0 - 10.4)	2290 (380 - 2750)	10.04 (1.98 - 11.69)	54
		10	07	07	—	—	3.53	2.38	2.38	—	—	8.3 (2.0 - 10.4)	2300 (380 - 2750)	10.09 (1.98 - 11.69)	54
		13	07	07	—	—	4.13	2.23	2.23	—	—	8.6 (2.0 - 10.4)	2300 (380 - 2750)	10.09 (1.98 - 11.69)	54
		16	07	07	—	—	4.39	2.16	2.16	—	—	8.7 (2.0 - 10.5)	2350 (380 - 2760)	10.31 (1.98 - 11.73)	54
		18	07	07	—	—	4.58	2.06	2.06	—	—	8.7 (2.0 - 10.5)	2350 (380 - 2760)	10.31 (1.98 - 11.73)	54
		10	10	07	—	—	3.18	3.18	2.14	—	—	8.5 (2.0 - 10.4)	2300 (380 - 2750)	10.09 (1.98 - 11.69)	54
		13	10	07	—	—	3.72	2.97	2.01	—	—	8.7 (2.0 - 10.5)	2350 (380 - 2760)	10.31 (1.98 - 11.73)	54
		16	10	07	—	—	3.92	2.85	1.93	—	—	8.7 (2.0 - 10.5)	2350 (380 - 2760)	10.31 (1.98 - 11.73)	54
		18	10	07	—	—	4.11	2.74	1.85	—	—	8.7 (2.0 - 10.5)	2350 (380 - 2760)	10.31 (1.98 - 11.73)	54
		13	13	07	—	—	3.43	3.43	1.85	—	—	8.7 (2.0 - 10.5)	2350 (380 - 2760)	10.31 (1.98 - 11.73)	54
		16	13	07	—	—	3.67	3.33	1.80	—	—	8.8 (2.0 - 10.6)	2400 (380 - 2780)	10.53 (1.98 - 11.82)	54
		18	13	07	—	—	3.85	3.21	1.73	—	—	8.8 (2.0 - 10.6)	2400 (380 - 2780)	10.53 (1.98 - 11.82)	54
		16	16	07	—	—	3.57	3.57	1.75	—	—	8.9 (2.0 - 10.7)	2450 (380 - 2790)	10.75 (1.98 - 11.86)	54
		18	16	07	—	—	3.76	3.45	1.69	—	—	8.9 (2.0 - 10.7)	2450 (380 - 2790)	10.75 (1.98 - 11.86)	54
		18	18	07	—	—	3.63	3.63	1.63	—	—	8.9 (2.0 - 10.7)	2450 (380 - 2790)	10.75 (1.98 - 11.86)	54
		10	10	10	—	—	2.87	2.87	2.87	—	—	8.6 (2.0 - 10.4)	2300 (380 - 2750)	10.09 (1.98 - 11.69)	54
13		10	10	—	—	3.35	2.68	2.68	—	—	8.7 (2.0 - 10.5)	2350 (380 - 2760)	10.31 (1.98 - 11.73)	54	
16		10	10	—	—	3.54	2.58	2.58	—	—	8.7 (2.0 - 10.5)	2350 (380 - 2760)	10.31 (1.98 - 11.73)	54	
18		10	10	—	—	3.73	2.49	2.49	—	—	8.7 (2.0 - 10.5)	2350 (380 - 2760)	10.31 (1.98 - 11.73)	54	
13		13	10	—	—	3.11	3.11	2.49	—	—	8.7 (2.0 - 10.5)	2350 (380 - 2760)	10.31 (1.98 - 11.73)	54	
16		13	10	—	—	3.34	3.03	2.43	—	—	8.8 (2.0 - 10.6)	2400 (380 - 2780)	10.53 (1.98 - 11.82)	54	
18		13	10	—	—	3.52	2.93	2.35	—	—	8.8 (2.0 - 10.6)	2400 (380 - 2780)	10.53 (1.98 - 11.82)	54	
16		16	10	—	—	3.26	3.26	2.37	—	—	8.9 (2.0 - 10.7)	2450 (380 - 2790)	10.75 (1.98 - 11.86)	54	
18		16	10	—	—	3.45	3.16	2.30	—	—	8.9 (2.0 - 10.7)	2450 (380 - 2790)	10.75 (1.98 - 11.86)	54	
18		18	10	—	—	3.34	3.34	2.23	—	—	8.9 (2.0 - 10.7)	2450 (380 - 2790)	10.75 (1.98 - 11.86)	54	
13		13	13	—	—	2.93	2.93	2.93	—	—	8.8 (2.0 - 10.6)	2400 (380 - 2780)	10.57 (1.98 - 11.82)	54	
16		13	13	—	—	3.16	2.87	2.87	—	—	8.9 (2.0 - 10.7)	2450 (380 - 2790)	10.75 (1.98 - 11.86)	54	
18	13	13	—	—	3.34	2.78	2.78	—	—	8.9 (2.0 - 10.7)	2450 (380 - 2790)	10.75 (1.98 - 11.86)	54		
16	16	13	—	—	3.06	3.06	2.78	—	—	8.9 (2.0 - 10.7)	2450 (380 - 2790)	10.75 (1.98 - 11.86)	54		
18	16	13	—	—	3.24	2.97	2.70	—	—	8.9 (2.0 - 10.7)	2450 (380 - 2790)	10.75 (1.98 - 11.86)	54		
18	18	13	—	—	3.14	3.14	2.62	—	—	8.9 (2.0 - 10.7)	2450 (380 - 2790)	10.75 (1.98 - 11.86)	54		

• The above specification values are those under the conditions that the indoor DB/WB=20/—°C and the outdoor DB/WB=7/6°C.

<Heating/240V> (Continued)

Power supply (V)	Operating status	Indoor unit					Unit Capacity					Total			Outdoor noise (dB)
		A	B	C	D	E	A	B	C	D	E	Heating capacity (kW)	Power consumption (W)	Operating current (A)	
240	4 units	07	07	07	07	—	2.20	2.20	2.20	2.20	—	8.8 (2.2 - 10.8)	2100 (450 - 2810)	9.21 (2.34 - 11.95)	54
		10	07	07	07	—	2.91	1.96	1.96	1.96	—	8.8 (2.2 - 10.8)	2100 (450 - 2810)	9.21 (2.34 - 11.95)	54
		13	07	07	07	—	3.36	1.81	1.81	1.81	—	8.8 (2.2 - 10.9)	2100 (460 - 2830)	9.21 (2.40 - 12.03)	54
		16	07	07	07	—	3.64	1.79	1.79	1.79	—	9.0 (2.2 - 10.9)	2250 (460 - 2830)	9.87 (2.40 - 12.03)	54
		18	07	07	07	—	3.83	1.72	1.72	1.72	—	9.0 (2.2 - 10.9)	2250 (460 - 2830)	9.87 (2.40 - 12.03)	54
		10	10	07	07	—	2.63	2.63	1.77	1.77	—	8.8 (2.2 - 10.8)	2100 (450 - 2810)	9.21 (2.34 - 11.95)	54
		13	10	07	07	—	3.09	2.47	1.67	1.67	—	8.9 (2.2 - 10.9)	2100 (460 - 2830)	9.21 (2.40 - 12.03)	54
		16	10	07	07	—	3.32	2.42	1.63	1.63	—	9.0 (2.2 - 10.9)	2250 (460 - 2830)	9.87 (2.40 - 12.03)	54
		18	10	07	07	—	3.51	2.34	1.58	1.58	—	9.0 (2.2 - 10.9)	2250 (460 - 2830)	9.87 (2.40 - 12.03)	54
		13	13	07	07	—	2.92	2.92	1.58	1.58	—	9.0 (2.2 - 10.9)	2250 (470 - 2830)	9.87 (2.45 - 12.03)	54
		16	13	07	07	—	3.11	2.83	1.53	1.53	—	9.0 (2.2 - 11.0)	2250 (480 - 2850)	9.87 (2.50 - 12.12)	54
		18	13	07	07	—	3.29	2.74	1.48	1.48	—	9.0 (2.2 - 11.0)	2250 (490 - 2850)	9.87 (2.55 - 12.12)	54
		16	16	07	07	—	3.02	3.02	1.48	1.48	—	9.0 (2.2 - 11.0)	2250 (500 - 2850)	9.87 (2.60 - 12.12)	54
		18	16	07	07	—	3.20	2.93	1.44	1.44	—	9.0 (2.2 - 11.0)	2250 (500 - 2850)	9.87 (2.60 - 12.12)	54
		18	18	07	07	—	3.10	3.10	1.40	1.40	—	9.0 (2.2 - 11.0)	2250 (490 - 2850)	9.87 (2.55 - 12.12)	54
		10	10	10	07	—	2.39	2.39	2.39	1.62	—	8.8 (2.2 - 10.8)	2100 (450 - 2810)	9.21 (2.34 - 11.95)	54
		13	10	10	07	—	2.83	2.27	2.27	1.53	—	8.9 (2.2 - 10.9)	2100 (460 - 2830)	9.21 (2.40 - 12.03)	54
		16	10	10	07	—	3.06	2.22	2.22	1.50	—	9.0 (2.2 - 10.9)	2250 (460 - 2830)	9.87 (2.40 - 12.03)	54
		18	10	10	07	—	3.23	2.16	2.16	1.46	—	9.0 (2.2 - 10.9)	2250 (460 - 2830)	9.87 (2.40 - 12.03)	54
		13	13	10	07	—	2.69	2.69	2.16	1.46	—	9.0 (2.2 - 10.9)	2250 (470 - 2830)	9.87 (2.45 - 12.03)	54
		16	13	10	07	—	2.88	2.62	2.09	1.41	—	9.0 (2.2 - 11.0)	2250 (480 - 2850)	9.87 (2.50 - 12.12)	54
		18	13	10	07	—	3.05	2.54	2.03	1.37	—	9.0 (2.2 - 11.0)	2250 (490 - 2850)	9.87 (2.55 - 12.12)	54
		16	16	10	07	—	2.80	2.80	2.03	1.37	—	9.0 (2.2 - 11.0)	2250 (500 - 2850)	9.87 (2.60 - 12.12)	54
		18	16	10	07	—	2.97	2.72	1.98	1.34	—	9.0 (2.2 - 11.0)	2250 (500 - 2850)	9.87 (2.60 - 12.12)	54
		18	18	10	07	—	2.89	2.89	1.93	1.30	—	9.0 (2.2 - 11.0)	2250 (490 - 2850)	9.87 (2.55 - 12.12)	54
		13	13	13	07	—	2.54	2.54	2.54	1.37	—	9.0 (2.2 - 11.0)	2250 (480 - 2850)	9.87 (2.50 - 12.12)	54
		16	13	13	07	—	2.72	2.47	2.47	1.34	—	9.0 (2.2 - 11.0)	2250 (490 - 2850)	9.87 (2.55 - 12.12)	54
		18	13	13	07	—	2.89	2.41	2.41	1.30	—	9.0 (2.2 - 11.0)	2250 (490 - 2850)	9.87 (2.55 - 12.12)	54
		16	16	13	07	—	2.65	2.65	2.41	1.30	—	9.0 (2.2 - 11.0)	2250 (490 - 2850)	9.87 (2.55 - 12.12)	54
		18	16	13	07	—	2.81	2.58	2.34	1.27	—	9.0 (2.2 - 11.0)	2250 (490 - 2850)	9.87 (2.55 - 12.12)	54
		18	18	13	07	—	2.74	2.74	2.28	1.23	—	9.0 (2.2 - 11.0)	2250 (490 - 2850)	9.87 (2.55 - 12.12)	54
		10	10	10	10	—	2.23	2.23	2.23	2.23	—	8.9 (2.2 - 10.8)	2100 (450 - 2810)	9.21 (2.34 - 11.95)	54
		13	10	10	10	—	2.62	2.09	2.09	2.09	—	8.9 (2.2 - 10.9)	2100 (460 - 2830)	9.21 (2.40 - 12.03)	54
		16	10	10	10	—	2.83	2.06	2.06	2.06	—	9.0 (2.2 - 10.9)	2250 (460 - 2830)	9.87 (2.40 - 12.03)	54
		18	10	10	10	—	3.00	2.00	2.00	2.00	—	9.0 (2.2 - 10.9)	2250 (460 - 2830)	9.87 (2.40 - 12.03)	54
		13	13	10	10	—	2.50	2.50	2.00	2.00	—	9.0 (2.2 - 10.9)	2250 (470 - 2830)	9.87 (2.45 - 12.03)	54
		16	13	10	10	—	2.68	2.43	1.95	1.95	—	9.0 (2.2 - 11.0)	2250 (480 - 2850)	9.87 (2.50 - 12.12)	54
		16	16	10	10	—	2.61	2.61	1.89	1.89	—	9.0 (2.2 - 11.0)	2250 (500 - 2850)	9.87 (2.60 - 12.12)	54
		18	13	10	10	—	2.84	2.37	1.89	1.89	—	9.0 (2.2 - 11.0)	2250 (490 - 2850)	9.87 (2.55 - 12.12)	54
		18	16	10	10	—	2.77	2.54	1.85	1.85	—	9.0 (2.2 - 11.0)	2250 (490 - 2850)	9.87 (2.55 - 12.12)	54
		18	18	10	10	—	2.70	2.70	1.80	1.80	—	9.0 (2.2 - 11.0)	2250 (490 - 2850)	9.87 (2.55 - 12.12)	54
		13	13	13	10	—	2.37	2.37	2.37	1.89	—	9.0 (2.2 - 11.0)	2250 (480 - 2850)	9.87 (2.50 - 12.12)	54
		16	13	13	10	—	2.54	2.31	2.31	1.85	—	9.0 (2.2 - 11.0)	2250 (490 - 2850)	9.87 (2.55 - 12.12)	54
		16	16	13	10	—	2.48	2.48	2.25	1.80	—	9.0 (2.2 - 11.0)	2250 (490 - 2850)	9.87 (2.55 - 12.12)	54
		18	13	13	10	—	2.70	2.25	2.25	1.80	—	9.0 (2.2 - 11.0)	2250 (490 - 2850)	9.87 (2.55 - 12.12)	54
		18	16	13	10	—	2.63	2.41	2.20	1.76	—	9.0 (2.2 - 11.0)	2250 (490 - 2850)	9.87 (2.55 - 12.12)	54
		18	18	13	10	—	2.57	2.57	2.14	1.71	—	9.0 (2.2 - 11.0)	2250 (490 - 2850)	9.87 (2.55 - 12.12)	54
		13	13	13	13	—	2.25	2.25	2.25	2.25	—	9.0 (2.2 - 11.0)	2250 (490 - 2850)	9.87 (2.55 - 12.12)	54
16	13	13	13	—	2.41	2.20	2.20	2.20	—	9.0 (2.2 - 11.0)	2250 (490 - 2850)	9.87 (2.55 - 12.12)	54		
18	13	13	13	—	2.57	2.14	2.14	2.14	—	9.0 (2.2 - 11.0)	2250 (490 - 2850)	9.87 (2.55 - 12.12)	54		
16	16	13	13	—	2.36	2.36	2.14	2.14	—	9.0 (2.2 - 11.0)	2250 (490 - 2850)	9.87 (2.55 - 12.12)	54		
18	16	13	13	—	2.51	2.30	2.09	2.09	—	9.0 (2.2 - 11.0)	2250 (490 - 2850)	9.87 (2.55 - 12.12)	54		
18	18	13	13	—	2.45	2.45	2.05	2.05	—	9.0 (2.2 - 11.0)	2250 (490 - 2850)	9.87 (2.55 - 12.12)	54		

• The above specification values are those under the conditions that the indoor DB/WB=20/—°C and the outdoor DB/WB=7/6°C.

<Heating/240V> (Continued)

Power supply (V)	Operating status	Indoor unit					Unit Capacity					Total			Outdoor noise (dB)
		A	B	C	D	E	A	B	C	D	E	Heating capacity (kW)	Power consumption (W)	Operating current (A)	
240	5 units	07	07	07	07	07	2.28	2.28	2.28	2.28	2.28	11.4 (3.4 - 13.4)	2690 (775 - 4020)	11.80 (4.04 - 17.09)	54
		10	07	07	07	07	3.16	2.13	2.13	2.13	2.13	11.7 (3.4 - 13.7)	2762 (775 - 4120)	12.11 (4.04 - 17.52)	54
		13	07	07	07	07	3.70	2.00	2.00	2.00	2.00	11.7 (3.4 - 13.7)	2762 (775 - 4120)	12.11 (4.04 - 17.52)	54
		16	07	07	07	07	3.95	1.94	1.94	1.94	1.94	11.7 (3.4 - 13.7)	2762 (775 - 4120)	12.11 (4.04 - 17.52)	54
		18	07	07	07	07	4.18	1.88	1.88	1.88	1.88	11.7 (3.4 - 13.7)	2762 (775 - 4120)	12.11 (4.04 - 17.52)	54
		10	10	07	07	07	2.91	2.91	1.96	1.96	1.96	11.7 (3.4 - 13.7)	2762 (775 - 4120)	12.11 (4.04 - 17.52)	54
		13	10	07	07	07	3.42	2.74	1.85	1.85	1.85	11.7 (3.4 - 13.7)	2762 (775 - 4120)	12.11 (4.04 - 17.52)	54
		16	10	07	07	07	3.66	2.66	1.79	1.79	1.79	11.7 (3.4 - 13.7)	2762 (775 - 4120)	12.11 (4.04 - 17.52)	54
		18	10	07	07	07	3.88	2.59	1.75	1.75	1.75	11.7 (3.4 - 13.7)	2762 (775 - 4120)	12.11 (4.04 - 17.52)	54
		13	13	07	07	07	3.23	3.23	1.75	1.75	1.75	11.7 (3.4 - 13.7)	2762 (775 - 4120)	12.11 (4.04 - 17.52)	54
		16	13	07	07	07	3.46	3.15	1.70	1.70	1.70	11.7 (3.4 - 13.7)	2762 (775 - 4120)	12.11 (4.04 - 17.52)	54
		18	13	07	07	07	3.68	3.06	1.65	1.65	1.65	11.7 (3.4 - 13.7)	2762 (775 - 4120)	12.11 (4.04 - 17.52)	54
		16	16	07	07	07	3.37	3.37	1.65	1.65	1.65	11.7 (3.4 - 13.7)	2762 (775 - 4120)	12.11 (4.04 - 17.52)	54
		18	16	07	07	07	3.58	3.28	1.61	1.61	1.61	11.7 (3.4 - 13.7)	2762 (775 - 4120)	12.11 (4.04 - 17.52)	54
		10	10	10	07	07	2.69	2.69	2.69	1.82	1.82	11.7 (3.4 - 13.7)	2762 (775 - 4120)	12.11 (4.04 - 17.52)	54
		13	10	10	07	07	3.18	2.54	2.54	1.72	1.72	11.7 (3.4 - 13.7)	2762 (775 - 4120)	12.11 (4.04 - 17.52)	54
		13	13	10	07	07	3.02	3.02	2.41	1.63	1.63	11.7 (3.4 - 13.7)	2762 (775 - 4120)	12.11 (4.04 - 17.52)	54
		16	10	10	07	07	3.40	2.48	2.48	1.67	1.67	11.7 (3.4 - 13.7)	2762 (775 - 4120)	12.11 (4.04 - 17.52)	54
		18	10	10	07	07	3.62	2.41	2.41	1.63	1.63	11.7 (3.4 - 13.7)	2762 (775 - 4120)	12.11 (4.04 - 17.52)	54
		13	13	13	07	07	2.87	2.87	2.87	1.55	1.55	11.7 (3.4 - 13.7)	2762 (775 - 4120)	12.11 (4.04 - 17.52)	54
		16	13	13	07	07	3.08	2.80	2.80	1.51	1.51	11.7 (3.4 - 13.7)	2762 (775 - 4120)	12.11 (4.04 - 17.52)	54
		18	13	13	07	07	3.28	2.73	2.73	1.48	1.48	11.7 (3.4 - 13.7)	2762 (775 - 4120)	12.11 (4.04 - 17.52)	54
		16	16	10	07	07	3.15	3.15	2.29	1.55	1.55	11.7 (3.4 - 13.7)	2762 (775 - 4120)	12.11 (4.04 - 17.52)	54
		18	16	10	07	07	3.36	3.08	2.24	1.51	1.51	11.7 (3.4 - 13.7)	2762 (775 - 4120)	12.11 (4.04 - 17.52)	54
		16	16	13	07	07	3.01	3.01	2.73	1.48	1.48	11.7 (3.4 - 13.7)	2762 (775 - 4120)	12.11 (4.04 - 17.52)	54
		18	16	13	07	07	3.21	2.94	2.67	1.44	1.44	11.7 (3.4 - 13.7)	2762 (775 - 4120)	12.11 (4.04 - 17.52)	54
		10	10	10	10	07	2.50	2.50	2.50	2.50	2.50	11.7 (3.4 - 13.7)	2762 (775 - 4120)	12.11 (4.04 - 17.52)	54
		13	10	10	10	07	2.97	2.38	2.38	2.38	2.38	11.7 (3.4 - 13.7)	2762 (775 - 4120)	12.11 (4.04 - 17.52)	54
		16	10	10	10	07	3.19	2.32	2.32	2.32	2.32	11.7 (3.4 - 13.7)	2762 (775 - 4120)	12.11 (4.04 - 17.52)	54
		13	13	10	10	07	2.83	2.83	2.26	2.26	2.26	11.7 (3.4 - 13.7)	2762 (775 - 4120)	12.11 (4.04 - 17.52)	54
		16	13	10	10	07	3.04	2.76	2.21	2.21	2.21	11.7 (3.4 - 13.7)	2762 (775 - 4120)	12.11 (4.04 - 17.52)	54
		16	16	10	10	07	2.97	2.97	2.16	2.16	2.16	11.7 (3.4 - 13.7)	2762 (775 - 4120)	12.11 (4.04 - 17.52)	54
		13	13	13	10	07	2.70	2.70	2.70	2.16	2.16	11.7 (3.4 - 13.7)	2762 (775 - 4120)	12.11 (4.04 - 17.52)	54
		16	13	13	10	07	2.90	2.64	2.64	2.11	2.11	11.7 (3.4 - 13.7)	2762 (775 - 4120)	12.11 (4.04 - 17.52)	54
		16	16	13	10	07	2.83	2.83	2.58	2.06	2.06	11.7 (3.4 - 13.7)	2762 (775 - 4120)	12.11 (4.04 - 17.52)	54
		13	13	13	13	07	2.58	2.58	2.58	2.58	2.58	11.7 (3.4 - 13.7)	2762 (775 - 4120)	12.11 (4.04 - 17.52)	54
		16	13	13	13	07	2.77	2.52	2.52	2.52	2.52	11.7 (3.4 - 13.7)	2762 (775 - 4120)	12.11 (4.04 - 17.52)	54
		16	16	13	13	07	2.72	2.72	2.47	2.47	2.47	11.7 (3.4 - 13.7)	2762 (775 - 4120)	12.11 (4.04 - 17.52)	54
		10	10	10	10	10	2.34	2.34	2.34	2.34	2.34	11.7 (3.4 - 13.7)	2762 (775 - 4120)	12.11 (4.04 - 17.52)	54
		13	10	10	10	10	2.79	2.23	2.23	2.23	2.23	11.7 (3.4 - 13.7)	2762 (775 - 4120)	12.11 (4.04 - 17.52)	54
16	10	10	10	10	2.99	2.18	2.18	2.18	2.18	11.7 (3.4 - 13.7)	2762 (775 - 4120)	12.11 (4.04 - 17.52)	54		
18	10	10	10	10	3.19	2.13	2.13	2.13	2.13	11.7 (3.4 - 13.7)	2762 (775 - 4120)	12.11 (4.04 - 17.52)	54		
13	13	10	10	10	2.66	2.66	2.13	2.13	2.13	11.7 (3.4 - 13.7)	2762 (775 - 4120)	12.11 (4.04 - 17.52)	54		
16	13	10	10	10	2.86	2.60	2.08	2.08	2.08	11.7 (3.4 - 13.7)	2762 (775 - 4120)	12.11 (4.04 - 17.52)	54		
18	13	10	10	10	3.05	2.54	2.03	2.03	2.03	11.7 (3.4 - 13.7)	2762 (775 - 4120)	12.11 (4.04 - 17.52)	54		
16	16	10	10	10	2.80	2.80	2.03	2.03	2.03	11.7 (3.4 - 13.7)	2762 (775 - 4120)	12.11 (4.04 - 17.52)	54		
13	13	13	10	10	2.54	2.54	2.54	2.03	2.03	11.7 (3.4 - 13.7)	2762 (775 - 4120)	12.11 (4.04 - 17.52)	54		
16	13	13	10	10	2.74	2.49	2.49	1.99	1.99	11.7 (3.4 - 13.7)	2762 (775 - 4120)	12.11 (4.04 - 17.52)	54		
18	13	13	10	10	2.93	2.44	2.44	1.95	1.95	11.7 (3.4 - 13.7)	2762 (775 - 4120)	12.11 (4.04 - 17.52)	54		
16	16	13	10	10	2.75	2.75	2.50	2.00	2.00	12.0 (3.4 - 14.0)	2833 (775 - 4200)	12.43 (4.04 - 17.86)	54		
13	13	13	13	10	2.44	2.44	2.44	2.44	2.44	11.7 (3.4 - 13.7)	2762 (775 - 4120)	12.11 (4.04 - 17.52)	54		
16	13	13	13	10	2.69	2.45	2.45	2.45	2.45	12.0 (3.4 - 14.0)	2833 (775 - 4200)	12.43 (4.04 - 17.86)	54		
18	13	13	13	10	2.88	2.40	2.40	2.40	2.40	12.0 (3.4 - 14.0)	2833 (775 - 4200)	12.43 (4.04 - 17.86)	54		
16	16	13	13	10	2.64	2.64	2.40	2.40	2.40	12.0 (3.4 - 14.0)	2833 (775 - 4200)	12.43 (4.04 - 17.86)	54		
13	13	13	13	13	2.40	2.40	2.40	2.40	2.40	12.0 (3.4 - 14.0)	2833 (775 - 4200)	12.43 (4.04 - 17.86)	54		
16	13	13	13	13	2.59	2.35	2.35	2.35	2.35	12.0 (3.4 - 14.0)	2833 (775 - 4200)	12.43 (4.04 - 17.86)	54		

• The above specification values are those under the conditions that the indoor DB/WB=20/–°C and the outdoor DB/WB=7/6°C.

## 2-2-1. Operation Characteristic Curve

<Cooling>

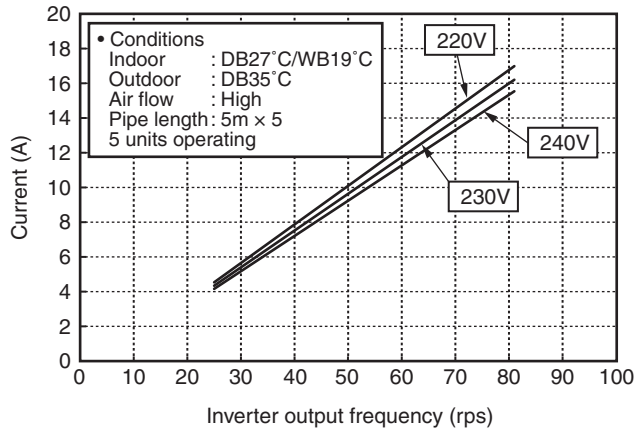

<Heating>

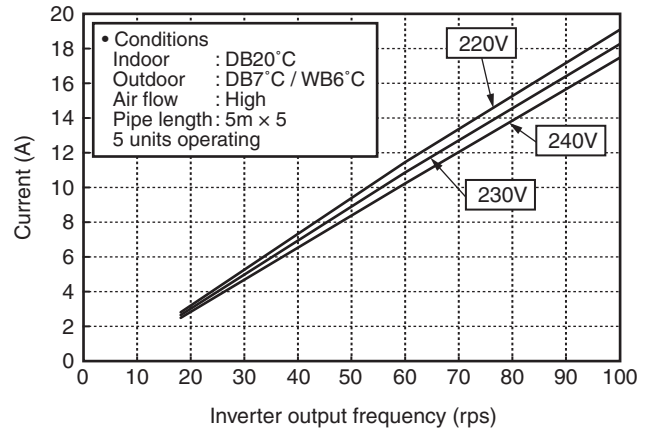

## 2-2-2. Capacity Variation Ratio According to Outdoor Temperature

<Cooling>

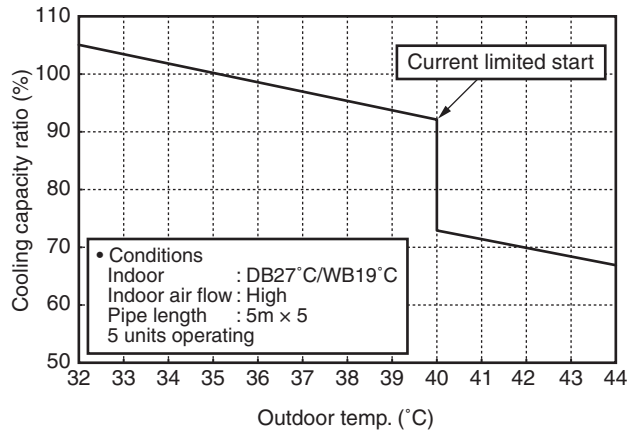

<Heating>

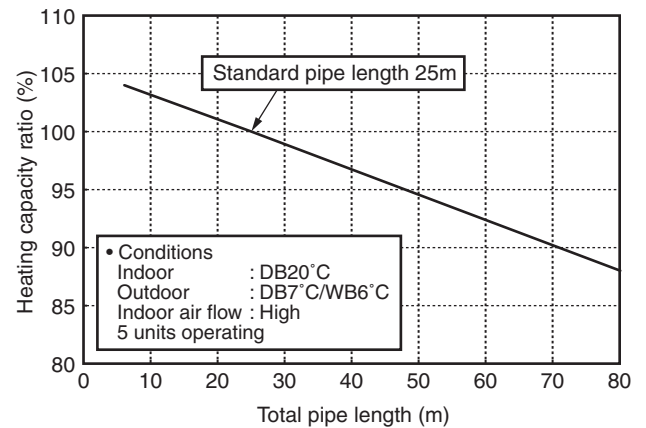
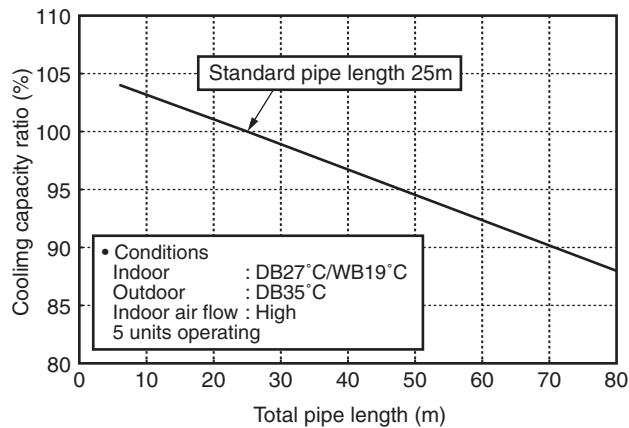
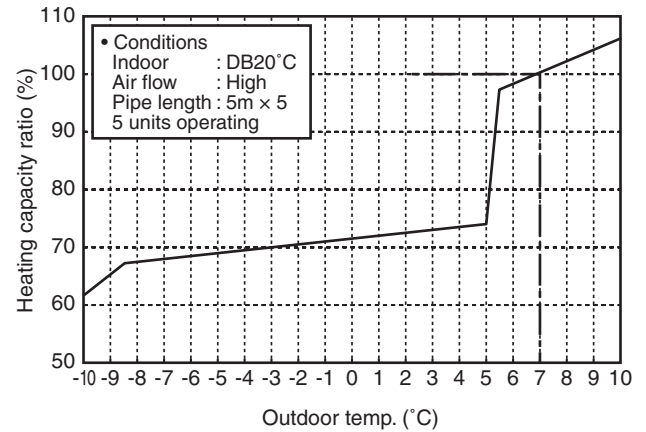

### 3. REFRIGERANT R410A

This air conditioner adopts the new refrigerant HFC (R410A) which does not damage the ozone layer.

The working pressure of the new refrigerant R410A is 1.6 times higher than conventional refrigerant (R22). The refrigerating oil is also changed in accordance with change of refrigerant, so be careful that water, dust, and existing refrigerant or refrigerating oil are not entered in the refrigerant cycle of the air conditioner using the new refrigerant during installation work or servicing time.

The next section describes the precautions for air conditioner using the new refrigerant. Conforming to contents of the next section together with the general cautions included in this manual, perform the correct and safe work.

#### 3-1. Safety During Installation/Servicing

As R410A's pressure is about 1.6 times higher than that of R22, improper installation/servicing may cause a serious trouble. By using tools and materials exclusive for R410A, it is necessary to carry out installation/servicing safely while taking the following precautions into consideration.

1. Never use refrigerant other than R410A in an air conditioner which is designed to operate with R410A.

If other refrigerant than R410A is mixed, pressure in the refrigeration cycle becomes abnormally high, and it may cause personal injury, etc. by a rupture.

2. Confirm the used refrigerant name, and use tools and materials exclusive for the refrigerant R410A.

The refrigerant name R410A is indicated on the visible place of the outdoor unit of the air conditioner using R410A as refrigerant. To prevent mischarging, the diameter of the service port differs from that of R22.

3. If a refrigeration gas leakage occurs during installation/servicing, be sure to ventilate fully.  
If the refrigerant gas comes into contact with fire, a poisonous gas may occur.
4. When installing or removing an air conditioner, do not allow air or moisture to remain in the refrigeration cycle. Otherwise, pressure in the refrigeration cycle may become abnormally high so that a rupture or personal injury may be caused.
5. After completion of installation work, check to make sure that there is no refrigeration gas leakage.

If the refrigerant gas leaks into the room, coming into contact with fire in the fan-driven heater, space heater, etc., a poisonous gas may occur.

6. When an air conditioning system charged with a large volume of refrigerant is installed in a small room, it is necessary to exercise care so that, even when refrigerant leaks, its concentration does not exceed the marginal level.

If the refrigerant gas leakage occurs and its concentration exceeds the marginal level, an oxygen starvation accident may result.

7. Be sure to carry out installation or removal according to the installation manual.  
Improper installation may cause refrigeration trouble, water leakage, electric shock, fire, etc.
8. Unauthorized modifications to the air conditioner may be dangerous. If a breakdown occurs please call a qualified air conditioner technician or electrician.

Improper repair may result in water leakage, electric shock and fire, etc.

#### 3-2. Refrigerant Piping Installation

##### 3-2-1. Piping Materials and Joints Used

For the refrigerant piping installation, copper pipes and joints are mainly used. Copper pipes and joints suitable for the refrigerant must be chosen and installed. Furthermore, it is necessary to use clean copper pipes and joints whose interior surfaces are less affected by contaminants.

##### 1. Copper Pipes

It is necessary to use seamless copper pipes which are made of either copper or copper alloy and it is desirable that the amount of residual oil is less than 40 mg/10 m. Do not use copper pipes having a collapsed, deformed or discolored portion (especially on the interior surface).

Otherwise, the expansion valve or capillary tube may become blocked with contaminants.

As an air conditioner using R410A incurs pressure higher than when using R22, it is necessary to choose adequate materials.

Thicknesses of copper pipes used with R410A are as shown in Table 3-2-1. Never use copper pipes thinner than 0.8 mm even when it is available on the market.

**Table 3-2-1 Thicknesses of annealed copper pipes**

		Thickness (mm)	
Nominal diameter	Outer diameter (mm)	R410A	R22
1/4	6.35	0.80	0.80
3/8	9.52	0.80	0.80
1/2	12.70	0.80	0.80
5/8	15.88	1.00	1.00

## 2. Joints

For copper pipes, flare joints or socket joints are used. Prior to use, be sure to remove all contaminants.

### a) Flare Joints

Flare joints used to connect the copper pipes cannot be used for pipings whose outer diameter exceeds 20 mm. In such a case, socket joints can be used.

Sizes of flare pipe ends, flare joint ends and flare nuts are as shown in Tables 3-2-3 to 3-2-6 below.

### b) Socket Joints

Socket joints are such that they are brazed for connections, and used mainly for thick pipings whose diameter is larger than 20 mm.

Thicknesses of socket joints are as shown in Table 3-2-2.

**Table 3-2-2 Minimum thicknesses of socket joints**

Nominal diameter	Reference outer diameter of copper pipe jointed (mm)	Minimum joint thickness (mm)
1/4	6.35	0.50
3/8	9.52	0.60
1/2	12.70	0.70
5/8	15.88	0.80

## 3-2-2. Processing of Piping Materials

When performing the refrigerant piping installation, care should be taken to ensure that water or dust does not enter the pipe interior, that no other oil than lubricating oils used in the installed air-water heat pump is used, and that refrigerant does not leak.

When using lubricating oils in the piping processing, use such lubricating oils whose water content has been removed. When stored, be sure to seal the container with an airtight cap or any other cover.

### 1. Flare processing procedures and precautions

#### a) Cutting the Pipe

By means of a pipe cutter, slowly cut the pipe so that it is not deformed.

#### b) Removing Burrs and Chips

If the flared section has chips or burrs, refrigerant leakage may occur.

Carefully remove all burrs and clean the cut surface before installation.

#### c) Insertion of Flare Nut



d) Flare Processing

Make certain that a clamp bar and copper pipe have been cleaned.

By means of the clamp bar, perform the flare processing correctly.

Use either a flare tool for R410A or conventional flare tool.

Flare processing dimensions differ according to the type of flare tool.

When using a conventional flare tool, be sure to secure "dimension A" by using a gauge for size adjustment.

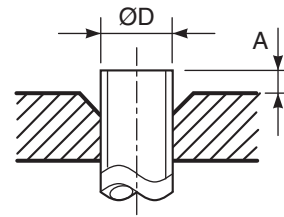

Fig. 3-2-1 Flare processing dimensions

Table 3-2-3 Dimensions related to flare processing for R410A

Nominal diameter	Outer diameter (mm)	Thickness (mm)	A (mm)		
			Flare tool for R410A clutch type	Conventional flare tool	
				Clutch type	Wing nut type
1/4	6.35	0.8	0 to 0.5	1.0 to 1.5	1.5 to 2.0
3/8	9.52	0.8	0 to 0.5	1.0 to 1.5	1.5 to 2.0
1/2	12.70	0.8	0 to 0.5	1.0 to 1.5	2.0 to 2.5
5/8	15.88	1.0	0 to 0.5	1.0 to 1.5	2.0 to 2.5

Table 3-2-4 Dimensions related to flare processing for R22

Nominal diameter	Outer diameter (mm)	Thickness (mm)	A (mm)		
			Flare tool for R22 clutch type	Conventional flare tool	
				Clutch type	Wing nut type
1/4	6.35	0.8	0 to 0.5	0.5 to 1.0	1.0 to 1.5
3/8	9.52	0.8	0 to 0.5	0.5 to 1.0	1.0 to 1.5
1/2	12.70	0.8	0 to 0.5	0.5 to 1.0	1.5 to 2.0
5/8	15.88	1.0	0 to 0.5	0.5 to 1.0	1.5 to 2.0

Table 3-2-5 Flare and flare nut dimensions for R410A

Nominal diameter	Outer diameter (mm)	Thickness (mm)	Dimension (mm)				Flare nut width (mm)
			A	B	C	D	
1/4	6.35	0.8	9.1	9.2	6.5	13	17
3/8	9.52	0.8	13.2	13.5	9.7	20	22
1/2	12.70	0.8	16.6	16.0	12.9	23	26
5/8	15.88	1.0	19.7	19.0	16.0	25	29



**Table 3-2-6 Flare and flare nut dimensions for R22**

Nominal diameter	Outer diameter (mm)	Thickness (mm)	Dimension (mm)				Flare nut width (mm)
			A	B	C	D	
1/4	6.35	0.8	9.0	9.2	6.5	13	17
3/8	9.52	0.8	13.0	13.5	9.7	20	22
1/2	12.70	0.8	16.2	16.0	12.9	20	24
5/8	15.88	1.0	19.7	19.0	16.0	23	27
3/4	19.05	1.0	23.3	24.0	19.2	34	36

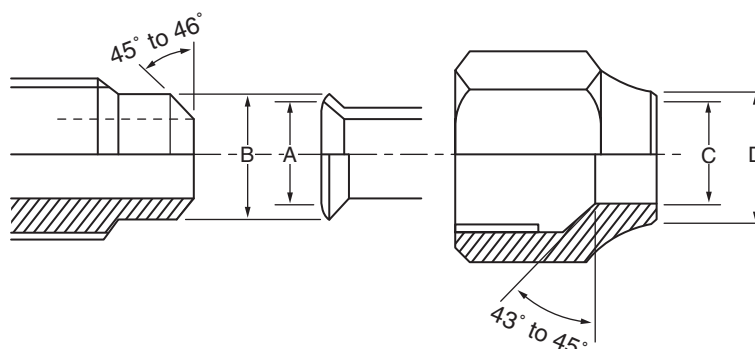

**Fig. 3-2-2 Relations between flare nut and flare seal surface**

## 2. Flare Connecting Procedures and Precautions

- Make sure that the flare and union portions do not have any scar or dust, etc.
- Correctly align the processed flare surface with the union axis.
- Tighten the flare with designated torque by means of a torque wrench.

The tightening torque for R410A is the same as that for conventional R22.

Incidentally, when the torque is weak, the gas leakage may occur. When it is strong, the flare nut may crack and may be made non-removable. When choosing the tightening torque, comply with values designated by manufacturers. Table 3-2-7 shows reference values.

### NOTE :

When applying oil to the flare surface, be sure to use oil designated by the manufacturer.

If any other oil is used, the lubricating oils may deteriorate and cause the compressor to burn out.

**Table 3-2-7 Tightening torque of flare for R410A [Reference values]**

Nominal diameter	Outer diameter (mm)	Tightening torque N·m (kgf·cm)	Tightening torque of torque wrenches available on the market N·m (kgf·cm)
1/4	6.35	14 to 18 (140 to 180)	16 (160), 18 (180)
3/8	9.52	33 to 42 (330 to 420)	42 (420)
1/2	12.70	50 to 62 (500 to 620)	55 (550)
5/8	15.88	63 to 77 (630 to 770)	65 (650)

### 3-3. Tools

#### 3-3-1. Required Tools

The service port diameter of packed valve of the outdoor unit in the air-water heat pump using R410A is changed to prevent mixing of other refrigerant.

To reinforce the pressure-resisting strength, flare processing dimensions and opposite side dimension of flare nut (For Ø12.7 copper pipe) of the refrigerant piping are lengthened.

The used refrigerating oil is changed, and mixing of oil may cause a trouble such as generation of sludge, clogging of capillary, etc. Accordingly, the tools to be used are classified into the following three types.

1. Tools exclusive for R410A (Those which cannot be used for conventional refrigerant (R22))
2. Tools exclusive for R410A, but can be also used for conventional refrigerant (R22)
3. Tools commonly used for R410A and for conventional refrigerant (R22)

The table below shows the tools exclusive for R410A and their interchangeability.

#### Tools exclusive for R410A (The following tools for R410A are required.)

Tools whose specifications are changed for R410A and their interchangeability

No.	Used tool	Usage	R410A air-water heat pump installation		Conventional air-water heat pump installation
			Existence of new equipment for R410A	Whether conventional equipment can be used	Whether new equipment can be used with conventional refrigerant
1	Flare tool	Pipe flaring	Yes	* (Note 1)	Yes
2	Copper pipe gauge for adjusting projection margin	Flaring by conventional flare tool	Yes	* (Note 1)	* (Note 1)
3	Torque wrench (For Ø12.7)	Connection of flare nut	Yes	No	No
4	Gauge manifold	Evacuating, refrigerant charge, run check, etc.	Yes	No	No
5	Charge hose				
6	Vacuum pump adapter	Vacuum evacuating	Yes	No	Yes
7	Electronic balance for refrigerant charging	Refrigerant charge	Yes	No	Yes
8	Refrigerant cylinder	Refrigerant charge	Yes	No	No
9	Leakage detector	Gas leakage check	Yes	No	Yes
10	Charging cylinder	Refrigerant charge	(Note 2)	No	No

**(Note 1)** When flaring is carried out for R410A using the conventional flare tools, adjustment of projection margin is necessary. For this adjustment, a copper pipe gauge, etc. are necessary.

**(Note 2)** Charging cylinder for R410A is being currently developed.

#### General tools (Conventional tools can be used.)

In addition to the above exclusive tools, the following equipments which serve also for R22 are necessary as the general tools.

- |   |   |
|---|---|
| <ol style="list-style-type: none"> <li>1. Vacuum pump<br/>Use vacuum pump by attaching vacuum pump adapter.</li> <li>2. Torque wrench (For Ø6.35, Ø9.52)</li> <li>3. Pipe cutter</li> <li>4. Reamer</li> <li>5. Pipe bender</li> <li>6. Level vial</li> </ol> | <ol style="list-style-type: none"> <li>7. Screwdriver (+, -)</li> <li>8. Spanner or Monkey wrench</li> <li>9. Hole core drill (Ø65)</li> <li>10. Hexagon wrench (Opposite side 4mm)</li> <li>11. Tape measure</li> <li>12. Metal saw</li> </ol> |
|---|---|

Also prepare the following equipments for other installation method and run check.

- |  |   |
|--|---|
| <ol style="list-style-type: none"> <li>1. Clamp meter</li> <li>2. Thermometer</li> </ol> | <ol style="list-style-type: none"> <li>3. Insulation resistance tester</li> <li>4. Electro-scope</li> </ol> |
|--|---|

### 3-4. Recharging of Refrigerant

When it is necessary to recharge refrigerant, charge the specified amount of new refrigerant according to the following steps.

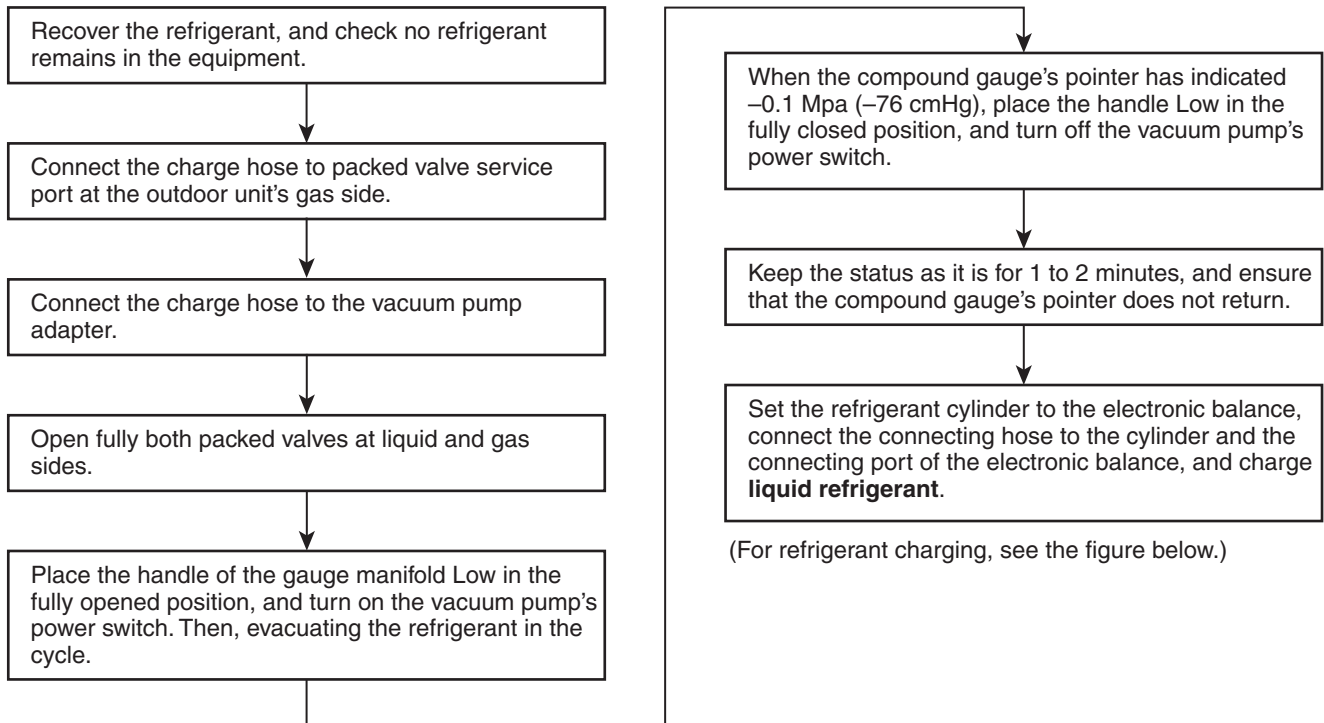

### ⚠ CAUTION

1. Never charge refrigerant exceeding the specified amount.
2. If the specified amount of refrigerant cannot be charged, charge refrigerant **bit by bit** in COOL mode.
3. Do not carry out additional charging.

When additional charging is carried out if refrigerant leaks, the refrigerant composition changes in the refrigeration cycle, that is characteristics of the air conditioner changes, refrigerant exceeding the specified amount is charged, and working pressure in the refrigeration cycle becomes abnormally high pressure, and may cause a rupture or personal injury.

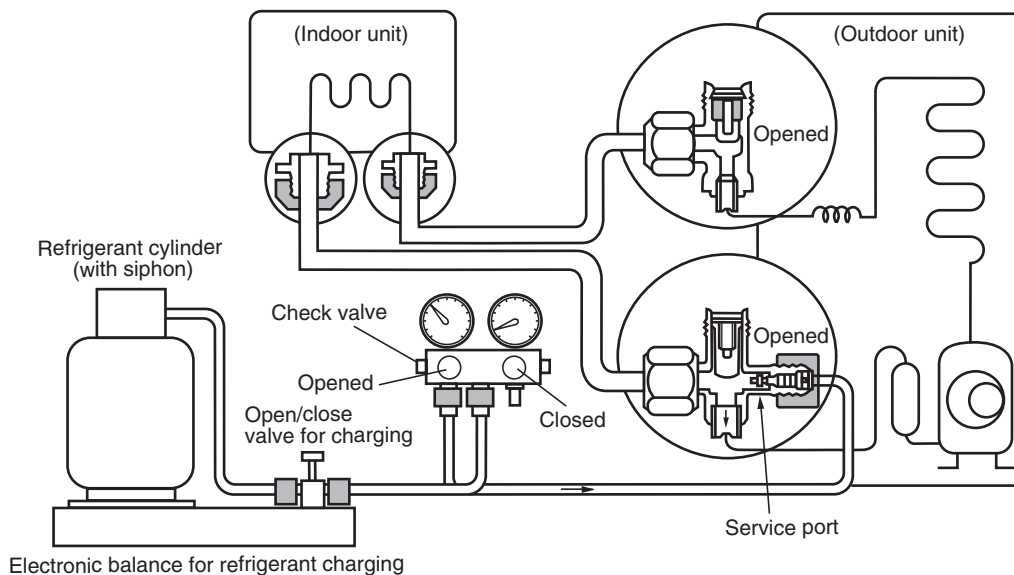
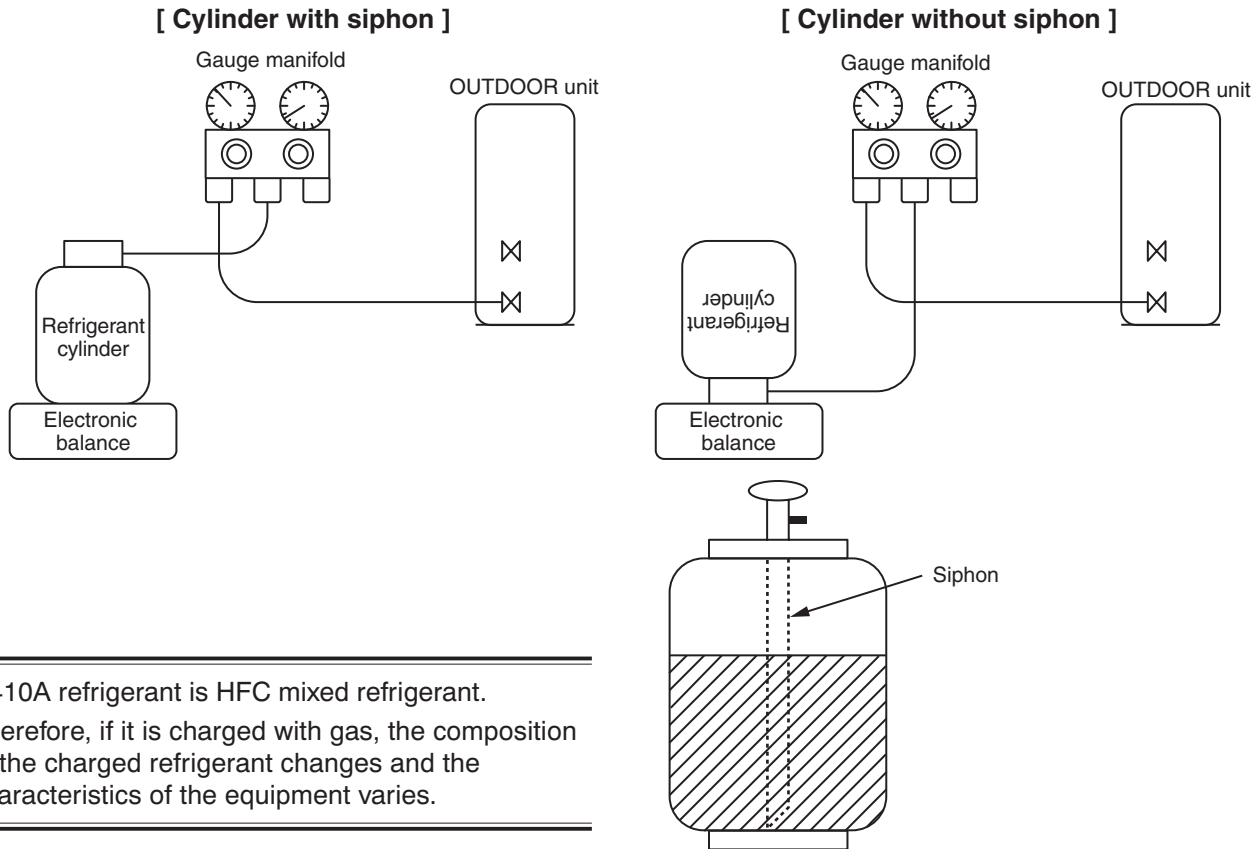

Fig. 3-4-1 Configuration of refrigerant charging

1. Be sure to make setting so that **liquid** can be charged.
2. When using a cylinder equipped with a siphon, liquid can be charged without turning it upside down.

It is necessary for charging refrigerant under condition of liquid because R410A is mixed type of refrigerant. Accordingly, when charging refrigerant from the refrigerant cylinder to the equipment, charge it turning the cylinder upside down if cylinder is not equipped with siphon.



R410A refrigerant is HFC mixed refrigerant. Therefore, if it is charged with gas, the composition of the charged refrigerant changes and the characteristics of the equipment varies.

Fig. 3-4-2

### 3-5. Brazing of Pipes

#### 3-5-1. Materials for Brazing

##### 1. Silver brazing filler

Silver brazing filler is an alloy mainly composed of silver and copper.

It is used to join iron, copper or copper alloy, and is relatively expensive though it excels in solderability.

##### 2. Phosphor bronze brazing filler

Phosphor bronze brazing filler is generally used to join copper or copper alloy.

##### 3. Low temperature brazing filler

Low temperature brazing filler is generally called solder, and is an alloy of tin and lead.

Since it is weak in adhesive strength, do not use it for refrigerant pipes.

1. Phosphor bronze brazing filler tends to react with sulfur and produce a fragile compound water solution, which may cause a gas leakage.

Therefore, use any other type of brazing filler at a hot spring resort, etc., and coat the surface with a paint.

2. When performing brazing again at time of servicing, use the same type of brazing filler.

#### 3-5-2. Flux

##### 1. Reason why flux is necessary

- By removing the oxide film and any foreign matter on the metal surface, it assists the flow of brazing filler.
- In the brazing process, it prevents the metal surface from being oxidized.
- By reducing the brazing filler's surface tension, the brazing filler adheres better to the treated metal.

## 2. Characteristics required for flux

- Activated temperature of flux coincides with the brazing temperature.
- Due to a wide effective temperature range, flux is hard to carbonize.
- It is easy to remove slag after brazing.
- The corrosive action to the treated metal and brazing filler is minimum.
- It excels in coating performance and is harmless to the human body.

As the flux works in a complicated manner as described above, it is necessary to select an adequate type of flux according to the type and shape of treated metal, type of brazing filler and brazing method, etc.

## 3. Types of flux

### • Noncorrosive flux

Generally, it is a compound of borax and boric acid.

It is effective in case where the brazing temperature is higher than 800°C.

### • Activated flux

Most of fluxes generally used for silver brazing are this type.

It features an increased oxide film removing capability due to the addition of compounds such as potassium fluoride, potassium chloride and sodium fluoride to the borax-boric acid compound.

## 4. Piping materials for brazing and used brazing filler/flux

Piping material	Used brazing filler	Used flux
Copper - Copper	Phosphor copper	Do not use
Copper - Iron	Silver	Paste flux
Iron - Iron	Silver	Vapor flux

1. Do not enter flux into the refrigeration cycle.
2. When chlorine contained in the flux remains within the pipe, the lubricating oil deteriorates. Therefore, use a flux which does not contain chlorine.
3. When adding water to the flux, use water which does not contain chlorine (e.g. distilled water or ion-exchange water).
4. Remove the flux after brazing.

## 3-5-3. Brazing

As brazing work requires sophisticated techniques, experiences based upon a theoretical knowledge, it must be performed by a person qualified.

In order to prevent the oxide film from occurring in the pipe interior during brazing, it is effective to proceed with brazing while letting dry Nitrogen gas (N<sub>2</sub>) flow.

### Never use gas other than Nitrogen gas.

#### 1. Brazing method to prevent oxidation

- 1) Attach a reducing valve and a flow-meter to the Nitrogen gas cylinder.
- 2) Use a copper pipe to direct the piping material, and attach a flow-meter to the cylinder.
- 3) Apply a seal onto the clearance between the piping material and inserted copper pipe for Nitrogen in order to prevent backflow of the Nitrogen gas.
- 4) When the Nitrogen gas is flowing, be sure to keep the piping end open.
- 5) Adjust the flow rate of Nitrogen gas so that it is lower than 0.05 m<sup>3</sup>/Hr or 0.02 MPa (0.2kgf/cm<sup>2</sup>) by means of the reducing valve.
- 6) After performing the steps above, keep the Nitrogen gas flowing until the pipe cools down to a certain extent (temperature at which pipes are touchable with hands).
- 7) Remove the flux completely after brazing.

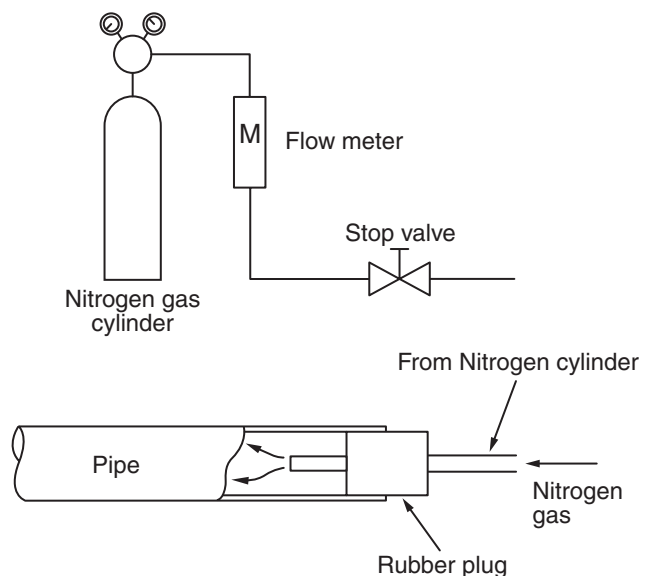
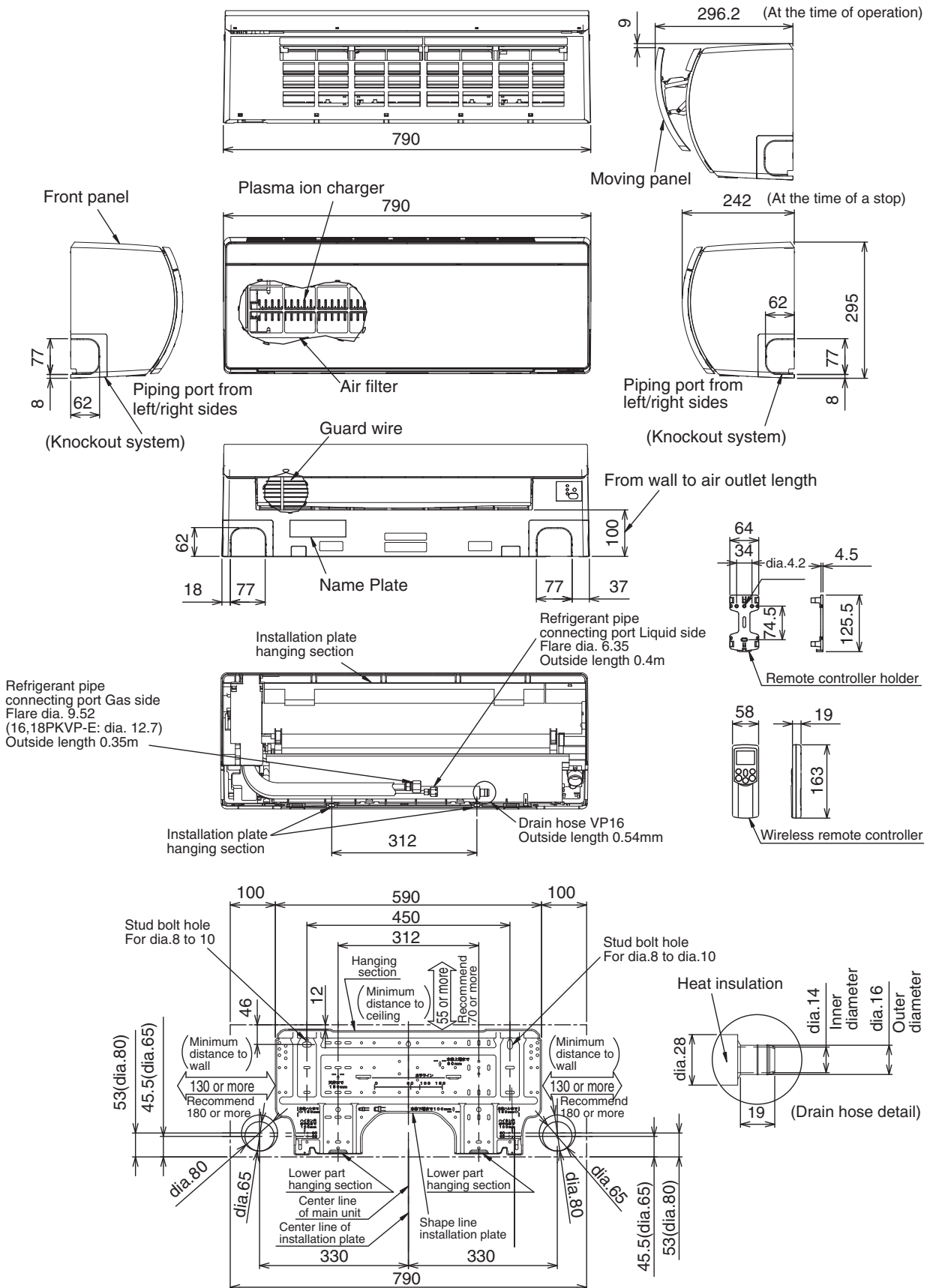

Fig. 3-5-1 Prevention of oxidation during brazing

## 4. CONSTRUCTION VIEWS

### 4-1. Indoor Unit

RAS-M10PKVP-E, RAS-M13PKVP-E, RAS-M16PKVP-E, RAS-M18PKVP-E





# 5. WIRING DIAGRAM

## 5-1. Indoor Unit

RAS-M10PKVP-E, RAS-M13PKVP-E, RAS-M16PKVP-E, RAS-M18PKVP-E

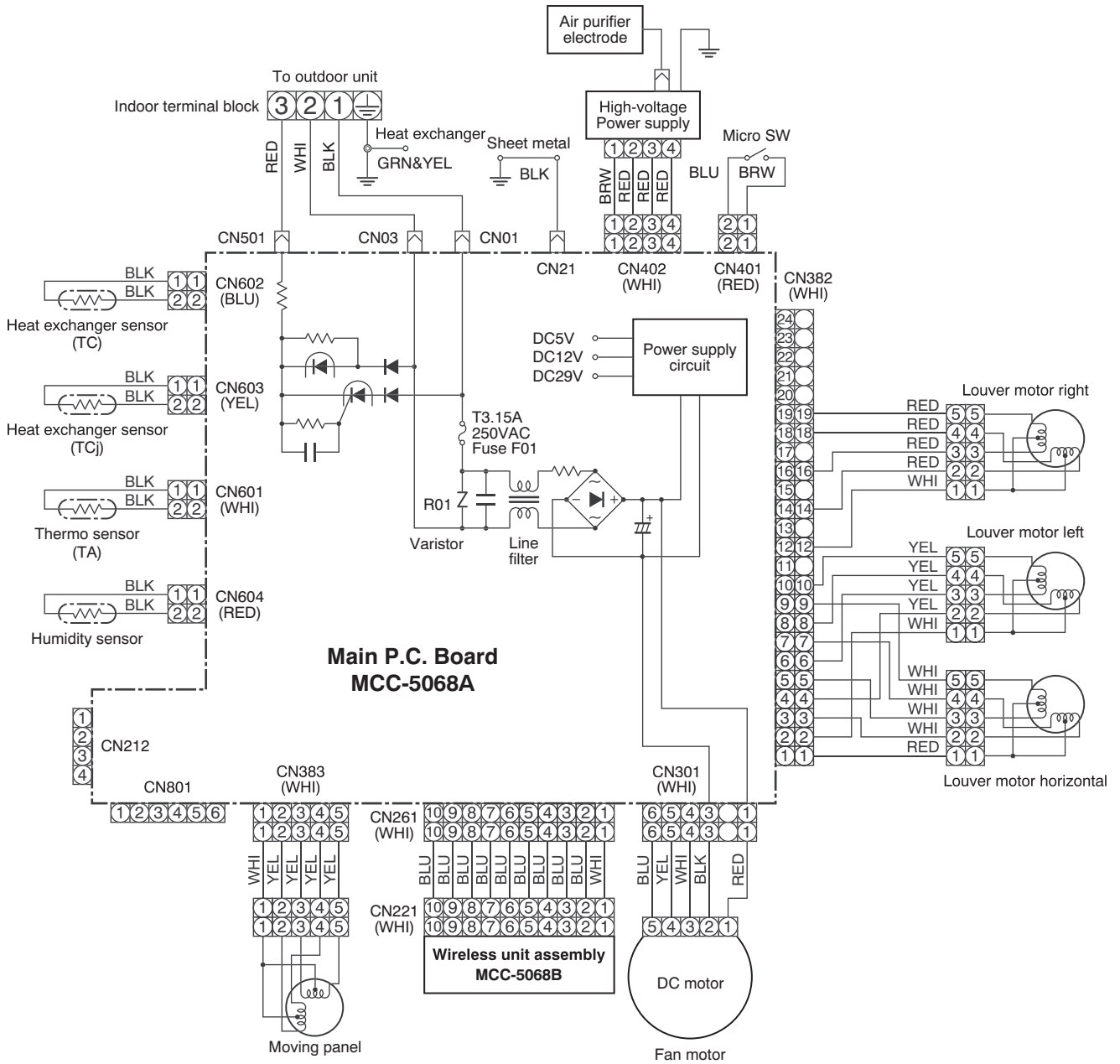



## 5-2. Outdoor Unit

### RAS-5M34UAV-E

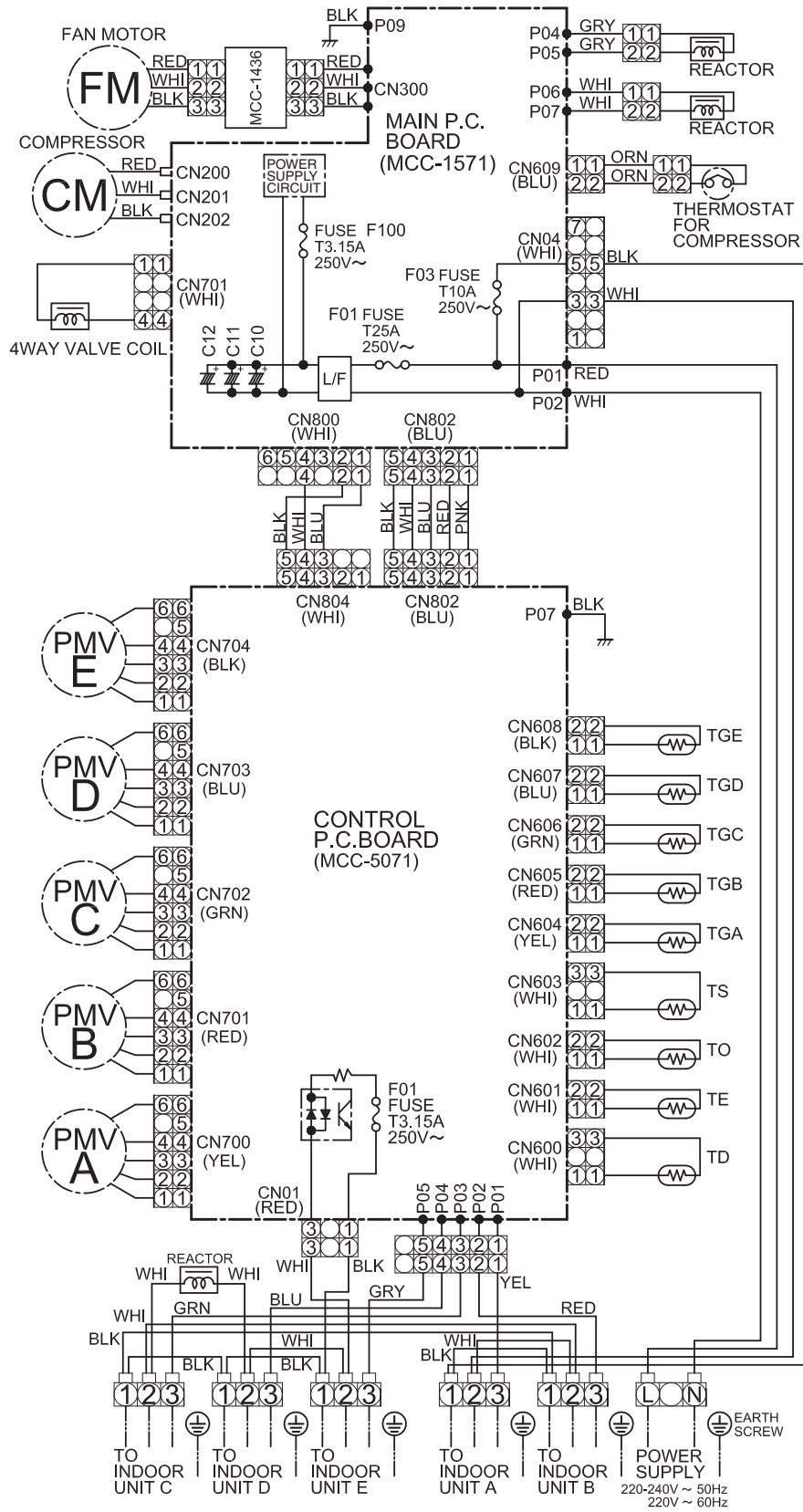

#### COLOR IDENTIFICATION

BLK:BLACK    GRN:GREEN  
 BLU:BLUE    WHI:WHITE  
 RED:RED     ORN:ORANGE  
 GRY:GRAY    YEL:YELLOW  
 PNK:PINK

Symbol	Part name
PMV	PULSE MOTOR VALVE
TD	DISCHARGE PIPE TEMP. SENSOR
TE	CONDENSER PIPE TEMP. SENSOR
TO	OUTDOOR TEMP. SENSOR
TS	SUCTION PIPE TEMP. SENSOR
TGA ~ TGE	GAS SIDE PIPE TEMP. SENSOR. A ~ E
L / F	LINE FILTER

## 6. SPECIFICATIONS OF ELECTRICAL PARTS

### 6-1. Indoor Unit

RAS-M10PKVP-E, RAS-M13PKVP-E, RAS-M16PKVP-E, RAS-M18PKVP-E

No.	Parts name	Type	Specifications
1	Fan motor (for indoor unit)	E: ICF-340-30-4 ND: ICF-340-30-4A	DC 280–340 V, 30 W
2	Room temp. sensor (TA-sensor)	(–)	10 kΩ at 25°C
3	Heat exchanger temp. sensor (TC-sensor)	(–)	10 kΩ at 25°C
4	Heat exchanger temp. sensor (TCj-sensor)	(–)	10 kΩ at 25°C
5	Humidity sensor	C7-M3R-TC2	31 kΩ, 60 % RH
6	Louver motor (Right, Left, Horizontal)	MP24Z3N	Output (Rated) 1 W, 16 poles, DC12 V
7	Louver motor (Moving panel)	MP24Z4N	Output (Rated) 1 W, 16 poles, DC12 V

### 6-2. Outdoor Unit

RAS-5M34UAV-E

No.	Parts name	Model name	Rating
1	Compressor	DA270A2F-20L	—
2	Outdoor fan motor	ICF-280-A100-1 (A)	Output 100 W
3	Reactor	CH-56	5.8 mH, 18.5 A
4	Reactor	CH-76	9.9 mH, 1 A
5	4-way valve coil	VHV-H	AC 200–240 V
6	PMV coil	UKV-A	DC 12 V
7	P.C. board (Main PCB)	MCC-1571	AC 220–240 V
8	P.C. board (Control PCB)	MCC-5071	AC 220–240 V
9	P.C. board (Fan motor connection)	MCC-1436	AC 220–240V
10	Fuse (Mounted on P.C. board MCC-1571)	—	AC 250V, 25 A
11	Fuse (Mounted on P.C. board MCC-1571)	—	AC 250V, 10 A
12	Fuse (Mounted on P.C. board MCC-1571, MCC-5071)	—	AC 250V, 3.15 A
13	Outdoor temp. sensor (TO sensor)	—	10 kΩ (25°C)
14	Evaporator temp. sensor (Te sensor)	—	10 kΩ (25°C)
15	Discharge temp. sensor (Td sensor)	—	50 kΩ (25°C)
16	Suction temp. sensor (Ts sensor)	—	10 kΩ (25°C)
17	Temp. sensor at A room gas side (TGa-sensor)	—	10 kΩ (25°C)
18	Temp. sensor at B room gas side (TGb-sensor)	—	10 kΩ (25°C)
19	Temp. sensor at C room gas side (TGc-sensor)	—	10 kΩ (25°C)
20	Temp. sensor at D room gas side (TGd-sensor)	—	10 kΩ (25°C)
21	Temp. sensor at E room gas side (TGe-sensor)	—	10 kΩ (25°C)
22	Compressor thermo.	US-622	ON: 90°C, OFF: 125°C
23	Terminal block (9P)	—	AC 250 V, 20 A

## 7. REFRIGERANT CYCLE DIAGRAM

RAS-M10PKVP-E, RAS-M13PKVP-E, RAS-M16PKVP-E, RAS-M18PKVP-E / RAS-5M34UAV-E

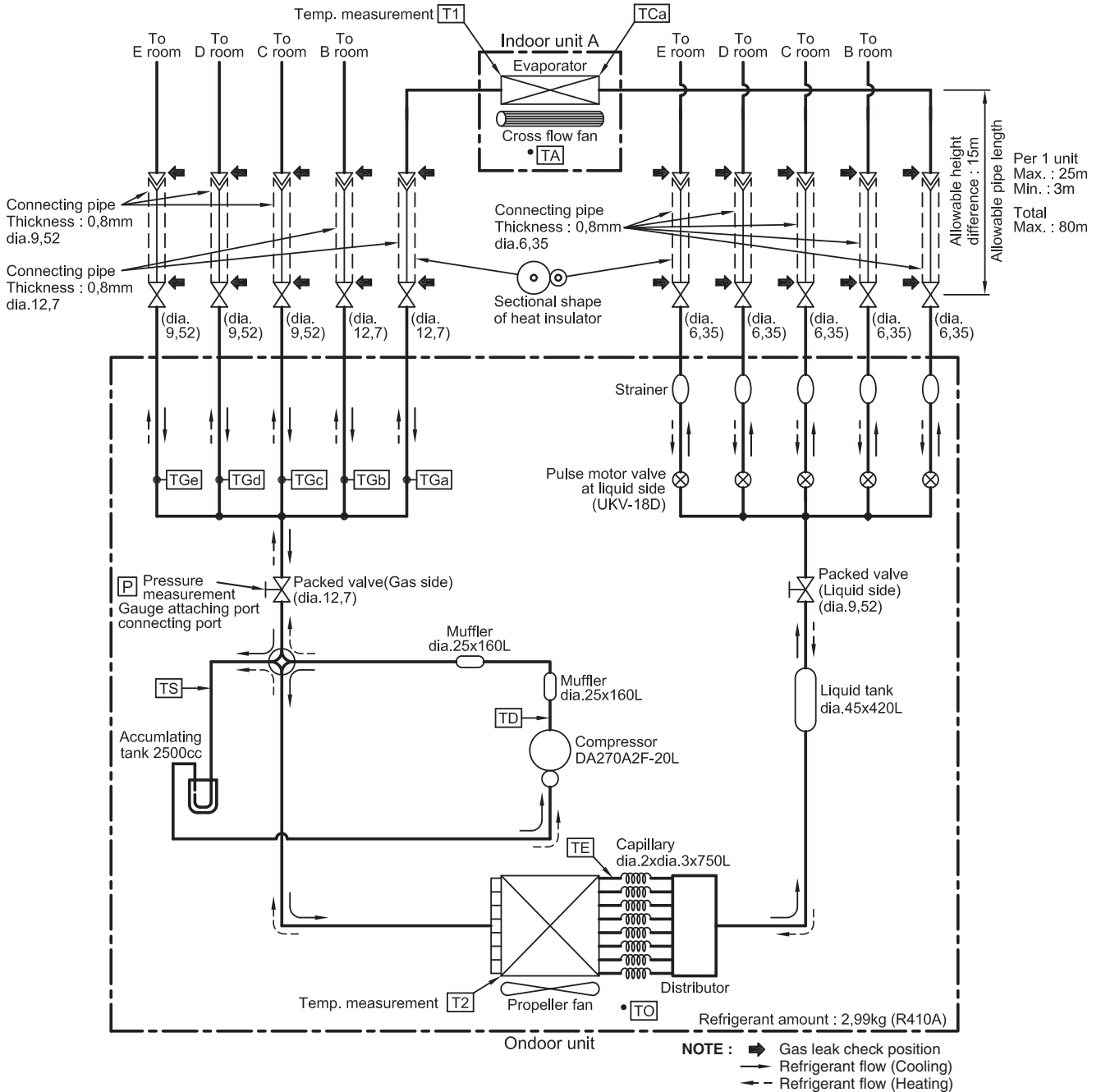

### NOTE :

- You need not add refrigerant if the piping length is 40m or less.
- If the length exceeds 41m, add 20g of refrigerant per 1 meter over.
- Connection of only one indoor unit is unavailable. Two or more indoor units should be connected.

## 7-2. Operation Data

### Outdoor Unit : RAS-5M34UAV-E

<Cooling>

Temperature condition		No. of operating units	Indoor unit					Standard pressure	Heat exchanger pipe temperature		Indoor fan	Outdoor fan	Compressor revolution (rps)
Indoor	Outdoor		A	B	C	D	E	P (MPa)	T1 (°C)	T2 (°C)			
27 / 19	35 / —	1 unit	07	—	—	—	—	0.9 to 1.1	15 to 17	36 to 42	High	LOW	16
			10	—	—	—	—	0.8 to 1.0	12 to 14	36 to 42	High	MED	19
			13	—	—	—	—	0.7 to 0.9	10 to 12	36 to 44	High	MED	31
			16	—	—	—	—	0.6 to 0.8	9 to 11	36 to 46	High	MED	40
			18	—	—	—	—	0.6 to 0.8	10 to 12	36 to 47	High	MED	45
		2 units	16	07	—	—	—	0.8 to 1.0	10 to 12	47 to 49	High	MED	40
			16	10	—	—	—	0.8 to 1.0	10 to 12	49 to 51	High	MED	43
			16	13	—	—	—	0.7 to 0.9	9 to 11	51 to 53	High	MED	48
			16	16	—	—	—	0.7 to 0.9	9 to 11	52 to 54	High	MED	51
			18	07	—	—	—	0.8 to 1.0	10 to 12	47 to 49	High	MED	43
			18	10	—	—	—	0.8 to 1.0	10 to 12	49 to 51	High	MED	46
			18	13	—	—	—	0.7 to 0.9	9 to 11	51 to 53	High	MED	51
			18	16	—	—	—	0.7 to 0.9	9 to 11	52 to 54	High	MED	51
		3 units	07	07	07	—	—	0.8 to 1.0	11 to 13	51 to 53	High	MED	49
			10	07	07	—	—	0.8 to 1.0	11 to 13	51 to 53	High	MED	49
			13	07	07	—	—	0.8 to 1.0	11 to 13	51 to 53	High	MED	49
			16	07	07	—	—	0.8 to 1.0	11 to 13	51 to 53	High	MED	49
			18	07	07	—	—	0.8 to 1.0	11 to 13	51 to 53	High	MED	49
			10	10	07	—	—	0.8 to 1.0	11 to 13	51 to 53	High	MED	49
			13	10	07	—	—	0.8 to 1.0	11 to 13	51 to 53	High	MED	49
			16	10	07	—	—	0.8 to 1.0	11 to 13	51 to 53	High	MED	49
			18	10	07	—	—	0.8 to 1.0	11 to 13	51 to 53	High	MED	49
			13	13	07	—	—	0.8 to 1.0	11 to 13	51 to 53	High	MED	49
			16	13	07	—	—	0.8 to 1.0	11 to 13	51 to 53	High	MED	49
			18	13	07	—	—	0.8 to 1.0	11 to 13	51 to 53	High	MED	49
			16	16	07	—	—	0.8 to 1.0	11 to 13	51 to 53	High	MED	49
			18	16	07	—	—	0.8 to 1.0	11 to 13	51 to 53	High	MED	49
			18	18	07	—	—	0.8 to 1.0	11 to 13	51 to 53	High	MED	49
			10	10	10	—	—	0.8 to 1.0	11 to 13	51 to 53	High	MED	49
			13	10	10	—	—	0.8 to 1.0	11 to 13	51 to 53	High	MED	49
			16	10	10	—	—	0.8 to 1.0	11 to 13	51 to 53	High	MED	49
			18	10	10	—	—	0.8 to 1.0	11 to 13	51 to 53	High	MED	49
			13	13	10	—	—	0.8 to 1.0	11 to 13	51 to 53	High	MED	49
			16	13	10	—	—	0.8 to 1.0	11 to 13	51 to 53	High	MED	49
			18	13	10	—	—	0.8 to 1.0	11 to 13	51 to 53	High	MED	49
			16	16	10	—	—	0.8 to 1.0	11 to 13	51 to 53	High	MED	49
			18	16	10	—	—	0.8 to 1.0	11 to 13	51 to 53	High	MED	49
			18	18	10	—	—	0.8 to 1.0	11 to 13	51 to 53	High	MED	49
			13	13	13	—	—	0.8 to 1.0	11 to 13	51 to 53	High	MED	49
			16	13	13	—	—	0.8 to 1.0	11 to 13	51 to 53	High	MED	49
18	13		13	—	—	0.8 to 1.0	11 to 13	51 to 53	High	MED	49		
16	16		13	—	—	0.8 to 1.0	11 to 13	51 to 53	High	MED	49		
18	16		13	—	—	0.8 to 1.0	11 to 13	51 to 53	High	MED	49		
18	18		13	—	—	0.8 to 1.0	11 to 13	51 to 53	High	MED	49		

### NOTES :

1. Measure surface temperature of heat exchanger pipe around of heat exchanger path U bent. (Thermistor thermometer)
2. Connecting piping condition : 5 meters × 5 units (5m/each indoor unit)

<Cooling> (Continued)

Temperature condition		No. of operating units	Indoor unit					Standard pressure P (MPa)	Heat exchanger pipe temperature		Indoor fan	Outdoor fan	Compressor revolution (rps)
Indoor	Outdoor		A	B	C	D	E		T1 (°C)	T2 (°C)			
27 / 19	35 / —	4 units	07	07	07	07	—	0.9 to 1.1	12 to 14	51 to 53	High	MED	50
			10	07	07	07	—	0.9 to 1.1	12 to 14	51 to 53	High	MED	50
			13	07	07	07	—	0.9 to 1.1	12 to 14	51 to 53	High	MED	50
			16	07	07	07	—	0.9 to 1.1	12 to 14	51 to 53	High	MED	50
			18	07	07	07	—	0.9 to 1.1	12 to 14	51 to 53	High	MED	50
			10	10	07	07	—	0.9 to 1.1	12 to 14	51 to 53	High	MED	50
			13	10	07	07	—	0.9 to 1.1	12 to 14	51 to 53	High	MED	50
			16	10	07	07	—	0.9 to 1.1	12 to 14	51 to 53	High	MED	50
			18	10	07	07	—	0.9 to 1.1	12 to 14	51 to 53	High	MED	50
			13	13	07	07	—	0.9 to 1.1	12 to 14	51 to 53	High	MED	50
			16	13	07	07	—	0.9 to 1.1	12 to 14	51 to 53	High	MED	50
			18	13	07	07	—	0.9 to 1.1	12 to 14	51 to 53	High	MED	50
			16	16	07	07	—	0.9 to 1.1	12 to 14	51 to 53	High	MED	50
			18	16	07	07	—	1.0 to 1.2	15 to 17	51 to 53	High	High	53
			18	18	07	07	—	1.0 to 1.2	15 to 17	51 to 53	High	High	55
			10	10	10	07	—	0.9 to 1.1	12 to 14	51 to 53	High	MED	50
			13	10	10	07	—	0.9 to 1.1	12 to 14	51 to 53	High	MED	50
			16	10	10	07	—	0.9 to 1.1	12 to 14	51 to 53	High	MED	50
			18	10	10	07	—	0.9 to 1.1	12 to 14	51 to 53	High	MED	50
			13	13	10	07	—	0.9 to 1.1	12 to 14	51 to 53	High	MED	50
			16	13	10	07	—	0.9 to 1.1	12 to 14	51 to 53	High	MED	50
			18	13	10	07	—	0.9 to 1.1	12 to 14	51 to 53	High	MED	50
			16	16	10	07	—	1.0 to 1.2	15 to 17	51 to 53	High	High	53
			18	16	10	07	—	1.0 to 1.2	15 to 17	51 to 53	High	High	55
			18	18	10	07	—	1.0 to 1.2	15 to 17	51 to 53	High	High	55
			13	13	13	07	—	1.0 to 1.2	15 to 17	51 to 53	High	High	53
			16	13	13	07	—	1.0 to 1.2	15 to 17	51 to 53	High	High	55
			18	13	13	07	—	1.0 to 1.2	15 to 17	51 to 53	High	High	55
			16	16	13	07	—	1.0 to 1.2	15 to 17	51 to 53	High	High	55
			18	16	13	07	—	1.0 to 1.2	15 to 17	51 to 53	High	High	55
			18	18	13	07	—	1.0 to 1.2	15 to 17	51 to 53	High	High	55
			10	10	10	10	—	0.9 to 1.1	12 to 14	51 to 53	High	MED	50
			13	10	10	10	—	0.9 to 1.1	12 to 14	51 to 53	High	MED	50
			16	10	10	10	—	0.9 to 1.1	12 to 14	51 to 53	High	MED	50
			18	10	10	10	—	0.9 to 1.1	12 to 14	51 to 53	High	MED	50
			13	13	10	10	—	0.9 to 1.1	12 to 14	51 to 53	High	MED	50
			16	13	10	10	—	1.0 to 1.2	15 to 17	51 to 53	High	High	53
			16	16	10	10	—	1.0 to 1.2	15 to 17	51 to 53	High	High	55
			18	13	10	10	—	1.0 to 1.2	15 to 17	51 to 53	High	High	55
			18	16	10	10	—	1.0 to 1.2	15 to 17	51 to 53	High	High	55
18	18	10	10	—	1.0 to 1.2	15 to 17	51 to 53	High	High	55			
13	13	13	10	—	1.0 to 1.2	15 to 17	51 to 53	High	High	55			
16	13	13	10	—	1.0 to 1.2	15 to 17	51 to 53	High	High	55			
18	13	13	10	—	1.0 to 1.2	15 to 17	51 to 53	High	High	55			
18	16	13	10	—	1.0 to 1.2	15 to 17	51 to 53	High	High	55			
18	18	13	10	—	1.0 to 1.2	15 to 17	51 to 53	High	High	55			
13	13	13	13	—	1.0 to 1.2	15 to 17	51 to 53	High	High	55			
16	13	13	13	—	1.0 to 1.2	15 to 17	51 to 53	High	High	55			
18	13	13	13	—	1.0 to 1.2	15 to 17	51 to 53	High	High	55			
16	16	13	13	—	1.0 to 1.2	15 to 17	51 to 53	High	High	55			
18	16	13	13	—	1.0 to 1.2	15 to 17	51 to 53	High	High	55			
18	18	13	13	—	1.0 to 1.2	15 to 17	51 to 53	High	High	55			

**NOTES :**

1. Measure surface temperature of heat exchanger pipe around of heat exchanger path U bent. (Thermistor thermometer)
2. Connecting piping condition : 5 meters × 5 units (5m/each indoor unit)

<Cooling> (Continued)

Temperature condition		No. of operating units	Indoor unit					Standard pressure P (MPa)	Heat exchanger pipe temperature		Indoor fan	Outdoor fan	Compressor revolution (rps)
Indoor	Outdoor		A	B	C	D	E		T1 (°C)	T2 (°C)			
27 / 19	35 / —	5 units	07	07	07	07	07	1.0 to 1.2	15 to 17	51 to 53	High	High	65
			10	07	07	07	07	1.0 to 1.2	15 to 17	51 to 53	High	High	65
			13	07	07	07	07	1.0 to 1.2	15 to 17	51 to 53	High	High	65
			16	07	07	07	07	1.0 to 1.2	15 to 17	51 to 53	High	High	65
			18	07	07	07	07	1.0 to 1.2	15 to 17	51 to 53	High	High	65
			10	10	07	07	07	1.0 to 1.2	15 to 17	51 to 53	High	High	65
			13	10	07	07	07	1.0 to 1.2	15 to 17	51 to 53	High	High	65
			16	10	07	07	07	1.0 to 1.2	15 to 17	51 to 53	High	High	65
			18	10	07	07	07	1.0 to 1.2	15 to 17	51 to 53	High	High	65
			13	13	07	07	07	1.0 to 1.2	15 to 17	51 to 53	High	High	65
			16	13	07	07	07	1.0 to 1.2	15 to 17	51 to 53	High	High	65
			18	13	07	07	07	1.0 to 1.2	15 to 17	51 to 53	High	High	65
			16	16	07	07	07	1.0 to 1.2	15 to 17	51 to 53	High	High	65
			18	16	07	07	07	1.0 to 1.2	15 to 17	51 to 53	High	High	65
			10	10	10	07	07	1.0 to 1.2	15 to 17	51 to 53	High	High	65
			13	10	10	07	07	1.0 to 1.2	15 to 17	51 to 53	High	High	65
			13	13	10	07	07	1.0 to 1.2	15 to 17	51 to 53	High	High	65
			16	10	10	07	07	1.0 to 1.2	15 to 17	51 to 53	High	High	65
			18	10	10	07	07	1.0 to 1.2	15 to 17	51 to 53	High	High	65
			13	13	13	07	07	1.0 to 1.2	15 to 17	51 to 53	High	High	65
			16	13	13	07	07	1.0 to 1.2	15 to 17	51 to 53	High	High	65
			18	13	13	07	07	1.0 to 1.2	15 to 17	51 to 53	High	High	65
			16	16	10	07	07	1.0 to 1.2	15 to 17	51 to 53	High	High	65
			18	16	10	07	07	1.0 to 1.2	15 to 17	51 to 53	High	High	65
			18	13	13	07	07	1.0 to 1.2	15 to 17	51 to 53	High	High	65
			16	16	13	07	07	1.0 to 1.2	15 to 17	51 to 53	High	High	65
			18	16	13	07	07	1.0 to 1.2	15 to 17	51 to 53	High	High	65
			10	10	10	10	07	1.0 to 1.2	15 to 17	51 to 53	High	High	65
			13	10	10	10	07	1.0 to 1.2	15 to 17	51 to 53	High	High	65
			16	10	10	10	07	1.0 to 1.2	15 to 17	51 to 53	High	High	65
			13	13	10	10	07	1.0 to 1.2	15 to 17	51 to 53	High	High	65
			16	13	10	10	07	1.0 to 1.2	15 to 17	51 to 53	High	High	65
			16	16	10	10	07	1.0 to 1.2	15 to 17	51 to 53	High	High	65
			13	13	13	10	07	1.0 to 1.2	15 to 17	51 to 53	High	High	65
			16	13	13	10	07	1.0 to 1.2	15 to 17	51 to 53	High	High	65
			13	13	13	13	07	1.0 to 1.2	15 to 17	51 to 53	High	High	65
			16	13	13	13	07	1.0 to 1.2	15 to 17	51 to 53	High	High	65
			16	16	13	13	07	1.0 to 1.2	15 to 17	51 to 53	High	High	65
			10	10	10	10	10	1.0 to 1.2	15 to 17	51 to 53	High	High	65
			13	10	10	10	10	1.0 to 1.2	15 to 17	51 to 53	High	High	65
			16	10	10	10	10	1.0 to 1.2	15 to 17	51 to 53	High	High	65
			18	10	10	10	10	1.0 to 1.2	15 to 17	51 to 53	High	High	65
			13	13	10	10	10	1.0 to 1.2	15 to 17	51 to 53	High	High	65
			16	13	10	10	10	1.0 to 1.2	15 to 17	51 to 53	High	High	65
			18	13	10	10	10	1.0 to 1.2	15 to 17	51 to 53	High	High	65
			16	16	10	10	10	1.0 to 1.2	15 to 17	51 to 53	High	High	65
			13	13	13	10	10	1.0 to 1.2	15 to 17	51 to 53	High	High	65
			16	13	13	10	10	1.0 to 1.2	15 to 17	51 to 53	High	High	65
18	13	13	10	10	1.0 to 1.2	15 to 17	51 to 53	High	High	65			
16	16	13	10	10	1.0 to 1.2	15 to 17	51 to 53	High	High	65			
13	13	13	13	10	1.0 to 1.2	15 to 17	51 to 53	High	High	65			
16	13	13	13	10	1.0 to 1.2	15 to 17	51 to 53	High	High	65			
18	13	13	13	10	1.0 to 1.2	15 to 17	51 to 53	High	High	65			
16	16	13	13	10	1.0 to 1.2	15 to 17	51 to 53	High	High	65			
13	13	13	13	13	1.0 to 1.2	15 to 17	51 to 53	High	High	65			
16	13	13	13	13	1.0 to 1.2	15 to 17	51 to 53	High	High	65			

**NOTES :**

1. Measure surface temperature of heat exchanger pipe around of heat exchanger path U bent. (Thermistor thermometer)
2. Connecting piping condition : 5 meters × 5 units (5m/each indoor unit)

**Outdoor Unit : RAS-5M34UAV-E**

<Heating>

Temperature condition		No. of operating units	Indoor unit					Standard pressure	Heat exchanger pipe temperature		Indoor fan	Outdoor fan	Compressor revolution (rps)
Indoor	Outdoor		A	B	C	D	E	P (MPa)	T1 (°C)	T2 (°C)			
20 / —	7 / 6	1 unit	07	—	—	—	—	2.1 to 2.3	36 to 38	3 to 5	High	MED	27
			10	—	—	—	—	2.7 to 2.9	44 to 46	2 to 4	High	MED	38
			13	—	—	—	—	3.2 to 3.4	52 to 54	2 to 4	High	MED	46
			16	—	—	—	—	3.6 to 3.9	53 to 55	2 to 4	High	MED	50
			18	—	—	—	—	3.6 to 3.9	53 to 55	2 to 4	High	MED	53
		2 units	16	07	—	—	—	2.8 to 3.0	45 to 47	0 to 2	High	MED	48
			16	10	—	—	—	2.9 to 3.1	46 to 48	0 to 2	High	MED	49
			16	13	—	—	—	3.0 to 3.2	47 to 49	-1 to 1	High	MED	52
			16	16	—	—	—	3.1 to 3.3	48 to 50	-1 to 1	High	MED	53
			18	07	—	—	—	2.9 to 3.1	46 to 48	0 to 2	High	MED	49
			18	10	—	—	—	2.9 to 3.1	46 to 48	0 to 2	High	MED	50
			18	13	—	—	—	3.1 to 3.3	48 to 50	-1 to 1	High	MED	53
			18	16	—	—	—	3.1 to 3.3	48 to 50	-1 to 1	High	MED	53
		3 units	07	07	07	—	—	2.3 to 2.5	38 to 40	-1 to 1	High	MED	59
			10	07	07	—	—	2.3 to 2.5	38 to 40	-1 to 1	High	MED	59
			13	07	07	—	—	2.3 to 2.5	38 to 40	-1 to 1	High	MED	59
			16	07	07	—	—	2.3 to 2.5	38 to 40	-1 to 1	High	MED	59
			18	07	07	—	—	2.3 to 2.5	38 to 40	-1 to 1	High	MED	59
			10	10	07	—	—	2.3 to 2.5	38 to 40	-1 to 1	High	MED	59
			13	10	07	—	—	2.3 to 2.5	38 to 40	-1 to 1	High	MED	59
			16	10	07	—	—	2.3 to 2.5	38 to 40	-1 to 1	High	MED	59
			18	10	07	—	—	2.5 to 2.7	37 to 39	-2 to 0	High	MED	60
			13	13	07	—	—	2.5 to 2.7	37 to 39	-2 to 0	High	MED	60
			16	13	07	—	—	2.5 to 2.7	37 to 39	-2 to 0	High	MED	60
			18	13	07	—	—	2.5 to 2.7	37 to 39	-2 to 0	High	MED	60
			16	16	07	—	—	2.5 to 2.7	37 to 39	-2 to 0	High	MED	60
			18	16	07	—	—	2.5 to 2.7	37 to 39	-2 to 0	High	MED	60
			18	18	07	—	—	2.5 to 2.7	37 to 39	-2 to 0	High	MED	60
			10	10	10	—	—	2.3 to 2.5	38 to 40	-1 to 1	High	MED	59
			13	10	10	—	—	2.3 to 2.5	38 to 40	-1 to 1	High	MED	59
			16	10	10	—	—	2.5 to 2.7	37 to 39	-2 to 0	High	MED	60
			18	10	10	—	—	2.5 to 2.7	37 to 39	-2 to 0	High	MED	60
			13	13	10	—	—	2.5 to 2.7	37 to 39	-2 to 0	High	MED	60
			16	13	10	—	—	2.5 to 2.7	37 to 39	-2 to 0	High	MED	60
			18	13	10	—	—	2.5 to 2.7	37 to 39	-2 to 0	High	MED	60
			16	16	10	—	—	2.5 to 2.7	37 to 39	-2 to 0	High	MED	60
			18	16	10	—	—	2.5 to 2.7	37 to 39	-2 to 0	High	MED	60
			18	18	10	—	—	2.5 to 2.7	37 to 39	-2 to 0	High	MED	60
			13	13	13	—	—	2.5 to 2.7	37 to 39	-2 to 0	High	MED	60
			16	13	13	—	—	2.5 to 2.7	37 to 39	-2 to 0	High	MED	60
			18	13	13	—	—	2.5 to 2.7	37 to 39	-2 to 0	High	MED	60
		16	16	13	—	—	2.5 to 2.7	37 to 39	-2 to 0	High	MED	60	
18	16	13	—	—	2.5 to 2.7	37 to 39	-2 to 0	High	MED	60			
18	18	13	—	—	2.5 to 2.7	37 to 39	-2 to 0	High	MED	60			

**NOTES :**

1. Measure surface temperature of heat exchanger pipe around of heat exchanger path U bent. (Thermistor thermometer)
2. Connecting piping condition : 5 meters × 5 units (5m/each indoor unit)



<Heating> (Continued)

Temperature condition		No. of operating units	Indoor unit					Standard pressure P (MPa)	Heat exchanger pipe temperature		Indoor fan	Outdoor fan	Compressor revolution (rps)
Indoor	Outdoor		A	B	C	D	E		T1 (°C)	T2 (°C)			
20 / —	7 / 6	4 units	07	07	07	07	—	2.5 to 2.7	35 to 37	-2 to 0	High	MED	60
			10	07	07	07	—	2.5 to 2.7	35 to 37	-2 to 0	High	MED	60
			13	07	07	07	—	2.5 to 2.7	35 to 37	-2 to 0	High	MED	60
			16	07	07	07	—	2.5 to 2.7	35 to 37	-2 to 0	High	MED	60
			18	07	07	07	—	2.5 to 2.7	35 to 37	-2 to 0	High	MED	60
			10	10	07	07	—	2.5 to 2.7	35 to 37	-2 to 0	High	MED	60
			13	10	07	07	—	2.5 to 2.7	35 to 37	-2 to 0	High	MED	60
			16	10	07	07	—	2.5 to 2.7	35 to 37	-2 to 0	High	MED	60
			18	10	07	07	—	2.5 to 2.7	35 to 37	-2 to 0	High	MED	60
			13	13	07	07	—	2.5 to 2.7	35 to 37	-2 to 0	High	MED	60
			16	13	07	07	—	2.5 to 2.7	35 to 37	-2 to 0	High	MED	60
			18	13	07	07	—	2.5 to 2.7	35 to 37	-2 to 0	High	MED	60
			16	16	07	07	—	2.5 to 2.7	35 to 37	-2 to 0	High	MED	60
			18	16	07	07	—	2.4 to 2.6	34 to 36	-2 to 0	High	MED	60
			18	18	07	07	—	2.2 to 2.4	33 to 35	-2 to 0	High	MED	60
			10	10	10	07	—	2.5 to 2.7	35 to 37	-2 to 0	High	MED	60
			13	10	10	07	—	2.5 to 2.7	35 to 37	-2 to 0	High	MED	60
			16	10	10	07	—	2.5 to 2.7	35 to 37	-2 to 0	High	MED	60
			18	10	10	07	—	2.5 to 2.7	35 to 37	-2 to 0	High	MED	60
			13	13	10	07	—	2.5 to 2.7	35 to 37	-2 to 0	High	MED	60
			16	13	10	07	—	2.5 to 2.7	35 to 37	-2 to 0	High	MED	60
			18	13	10	07	—	2.5 to 2.7	35 to 37	-2 to 0	High	MED	60
			16	16	10	07	—	2.4 to 2.6	34 to 36	-2 to 0	High	MED	69
			18	16	10	07	—	2.2 to 2.4	33 to 35	-2 to 0	High	MED	60
			18	18	10	07	—	2.2 to 2.4	33 to 35	-2 to 0	High	MED	60
			13	13	13	07	—	2.4 to 2.6	34 to 36	-2 to 0	High	MED	60
			16	13	13	07	—	2.2 to 2.4	33 to 35	-2 to 0	High	MED	60
			18	13	13	07	—	2.2 to 2.4	33 to 35	-2 to 0	High	MED	60
			16	16	13	07	—	2.2 to 2.4	33 to 35	-2 to 0	High	MED	60
			18	16	13	07	—	2.2 to 2.4	33 to 35	-2 to 0	High	MED	60
			18	18	13	07	—	2.2 to 2.4	33 to 35	-2 to 0	High	MED	60
			10	10	10	10	—	2.5 to 2.7	35 to 37	-2 to 0	High	MED	60
			13	10	10	10	—	2.5 to 2.7	35 to 37	-2 to 0	High	MED	60
			16	10	10	10	—	2.5 to 2.7	35 to 37	-2 to 0	High	MED	60
			18	10	10	10	—	2.5 to 2.7	35 to 37	-2 to 0	High	MED	60
			13	13	10	10	—	2.5 to 2.7	35 to 37	-2 to 0	High	MED	60
			16	13	10	10	—	2.4 to 2.6	34 to 36	-2 to 0	High	MED	60
			16	16	10	10	—	2.2 to 2.4	33 to 35	-2 to 0	High	MED	60
			18	13	10	10	—	2.2 to 2.4	33 to 35	-2 to 0	High	MED	60
			18	16	10	10	—	2.2 to 2.4	33 to 35	-2 to 0	High	MED	60
18	18	10	10	—	2.2 to 2.4	33 to 35	-2 to 0	High	MED	60			
13	13	13	10	—	2.2 to 2.4	33 to 35	-2 to 0	High	MED	60			
16	13	13	10	—	2.2 to 2.4	33 to 35	-2 to 0	High	MED	60			
18	13	13	10	—	2.2 to 2.4	33 to 35	-2 to 0	High	MED	60			
18	16	13	10	—	2.2 to 2.4	33 to 35	-2 to 0	High	MED	60			
18	18	13	10	—	2.2 to 2.4	33 to 35	-2 to 0	High	MED	60			
13	13	13	13	—	2.2 to 2.4	33 to 35	-2 to 0	High	MED	60			
16	13	13	13	—	2.2 to 2.4	33 to 35	-2 to 0	High	MED	60			
18	13	13	13	—	2.2 to 2.4	33 to 35	-2 to 0	High	MED	60			
16	16	13	13	—	2.2 to 2.4	33 to 35	-2 to 0	High	MED	60			
18	16	13	13	—	2.2 to 2.4	33 to 35	-2 to 0	High	MED	60			
18	18	13	13	—	2.2 to 2.4	33 to 35	-2 to 0	High	MED	60			

**NOTES :**

1. Measure surface temperature of heat exchanger pipe around of heat exchanger path U bent. (Thermistor thermometer)
2. Connecting piping condition : 5 meters × 5 units (5m/each indoor unit)

<Heating> (Continued)

Temperature condition		No. of operating units	Indoor unit					Standard pressure P (MPa)	Heat exchanger pipe temperature		Indoor fan	Outdoor fan	Compressor revolution (rps)
Indoor	Outdoor		A	B	C	D	E		T1 (°C)	T2 (°C)			
20 / —	7 / 6	5 units	07	07	07	07	07	2.0 to 2.2	32 to 35	-2 to 0	High	MED	78
			10	07	07	07	07	2.0 to 2.2	32 to 35	-2 to 0	High	MED	78
			13	07	07	07	07	2.0 to 2.2	32 to 35	-2 to 0	High	MED	78
			16	07	07	07	07	2.0 to 2.2	32 to 35	-2 to 0	High	MED	78
			18	07	07	07	07	2.0 to 2.2	32 to 35	-2 to 0	High	MED	78
			10	10	07	07	07	2.0 to 2.2	32 to 35	-2 to 0	High	MED	78
			13	10	07	07	07	2.0 to 2.2	32 to 35	-2 to 0	High	MED	78
			16	10	07	07	07	2.0 to 2.2	32 to 35	-2 to 0	High	MED	78
			18	10	07	07	07	2.0 to 2.2	32 to 35	-2 to 0	High	MED	78
			13	13	07	07	07	2.0 to 2.2	32 to 35	-2 to 0	High	MED	78
			16	13	07	07	07	2.0 to 2.2	32 to 35	-2 to 0	High	MED	78
			18	13	07	07	07	2.0 to 2.2	32 to 35	-2 to 0	High	MED	78
			16	16	07	07	07	2.0 to 2.2	32 to 35	-2 to 0	High	MED	78
			18	16	07	07	07	2.0 to 2.2	32 to 35	-2 to 0	High	MED	78
			10	10	10	07	07	2.0 to 2.2	32 to 35	-2 to 0	High	MED	78
			13	10	10	07	07	2.0 to 2.2	32 to 35	-2 to 0	High	MED	78
			13	13	10	07	07	2.0 to 2.2	32 to 35	-2 to 0	High	MED	78
			16	10	10	07	07	2.0 to 2.2	32 to 35	-2 to 0	High	MED	78
			18	10	10	07	07	2.0 to 2.2	32 to 35	-2 to 0	High	MED	78
			13	13	13	07	07	2.0 to 2.2	32 to 35	-2 to 0	High	MED	78
			16	13	13	07	07	2.0 to 2.2	32 to 35	-2 to 0	High	MED	78
			18	13	13	07	07	2.0 to 2.2	32 to 35	-2 to 0	High	MED	78
			16	16	10	07	07	2.0 to 2.2	32 to 35	-2 to 0	High	MED	78
			18	16	10	07	07	2.0 to 2.2	32 to 35	-2 to 0	High	MED	78
			18	13	13	07	07	2.0 to 2.2	32 to 35	-2 to 0	High	MED	78
			16	16	13	07	07	2.0 to 2.2	32 to 35	-2 to 0	High	MED	78
			18	16	13	07	07	2.0 to 2.2	32 to 35	-2 to 0	High	MED	78
			10	10	10	10	07	2.0 to 2.2	32 to 35	-2 to 0	High	MED	78
			13	10	10	10	07	2.0 to 2.2	32 to 35	-2 to 0	High	MED	78
			16	10	10	10	07	2.0 to 2.2	32 to 35	-2 to 0	High	MED	78
			13	13	10	10	07	2.0 to 2.2	32 to 35	-2 to 0	High	MED	78
			16	13	10	10	07	2.0 to 2.2	32 to 35	-2 to 0	High	MED	78
			16	16	10	10	07	2.0 to 2.2	32 to 35	-2 to 0	High	MED	78
			13	13	13	10	07	2.0 to 2.2	32 to 35	-2 to 0	High	MED	78
			16	13	13	10	07	2.0 to 2.2	32 to 35	-2 to 0	High	MED	78
			13	13	13	13	07	2.0 to 2.2	32 to 35	-2 to 0	High	MED	78
			16	13	13	13	07	2.0 to 2.2	32 to 35	-2 to 0	High	MED	78
			16	16	13	13	07	2.0 to 2.2	32 to 35	-2 to 0	High	MED	78
			10	10	10	10	10	2.0 to 2.2	32 to 35	-2 to 0	High	MED	78
			13	10	10	10	10	2.0 to 2.2	32 to 35	-2 to 0	High	MED	78
16	10	10	10	10	2.0 to 2.2	32 to 35	-2 to 0	High	MED	78			
18	10	10	10	10	2.0 to 2.2	32 to 35	-2 to 0	High	MED	78			
13	13	10	10	10	2.0 to 2.2	32 to 35	-2 to 0	High	MED	78			
16	13	10	10	10	2.0 to 2.2	32 to 35	-2 to 0	High	MED	78			
18	13	10	10	10	2.0 to 2.2	32 to 35	-2 to 0	High	MED	78			
16	16	10	10	10	2.0 to 2.2	32 to 35	-2 to 0	High	MED	78			
13	13	13	10	10	2.0 to 2.2	32 to 35	-2 to 0	High	MED	78			
16	13	13	10	10	2.0 to 2.2	32 to 35	-2 to 0	High	MED	78			
18	13	13	10	10	2.0 to 2.2	32 to 35	-2 to 0	High	MED	78			
16	16	13	10	10	2.0 to 2.2	32 to 35	-2 to 0	High	MED	78			
13	13	13	13	10	2.0 to 2.2	32 to 35	-2 to 0	High	MED	78			
16	13	13	13	10	2.0 to 2.2	32 to 35	-2 to 0	High	MED	78			
18	13	13	13	10	2.0 to 2.2	32 to 35	-2 to 0	High	MED	78			
16	16	13	13	10	2.0 to 2.2	32 to 35	-2 to 0	High	MED	78			
13	13	13	13	13	2.0 to 2.2	32 to 35	-2 to 0	High	MED	78			
16	13	13	13	13	2.0 to 2.2	32 to 35	-2 to 0	High	MED	78			

**NOTES :**

1. Measure surface temperature of heat exchanger pipe around of heat exchanger path U bent. (Thermistor thermometer)
2. Connecting piping condition : 5 meters × 5 units (5m/each indoor unit)

## 8. CONTROL BLOCK DIAGRAM

### 8-1. Indoor Unit

RAS-M10PKVP-E, RAS-M13PKVP-E, RAS-M16PKVP-E, RAS-M18PKVP-E

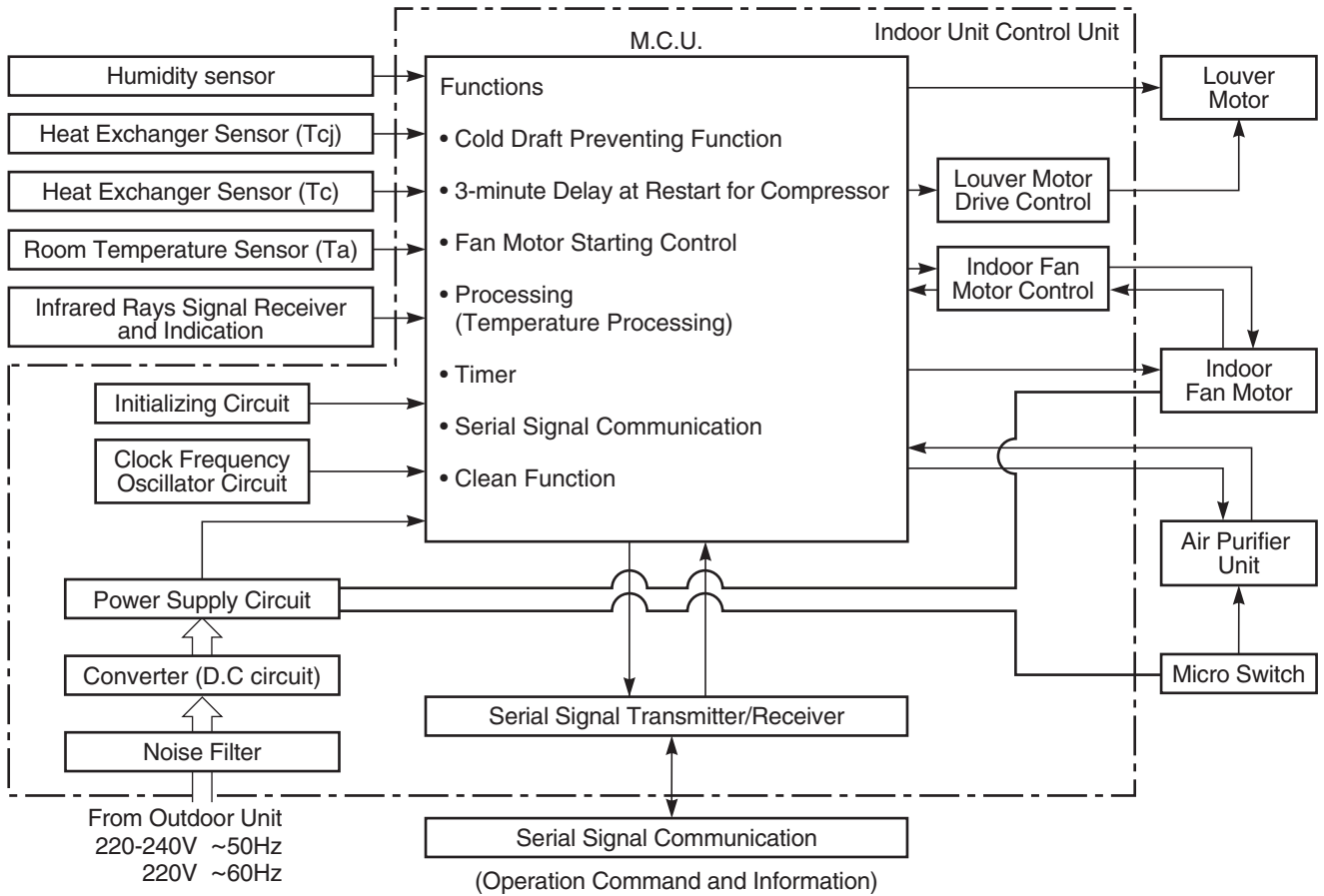

### REMOTE CONTROLLER

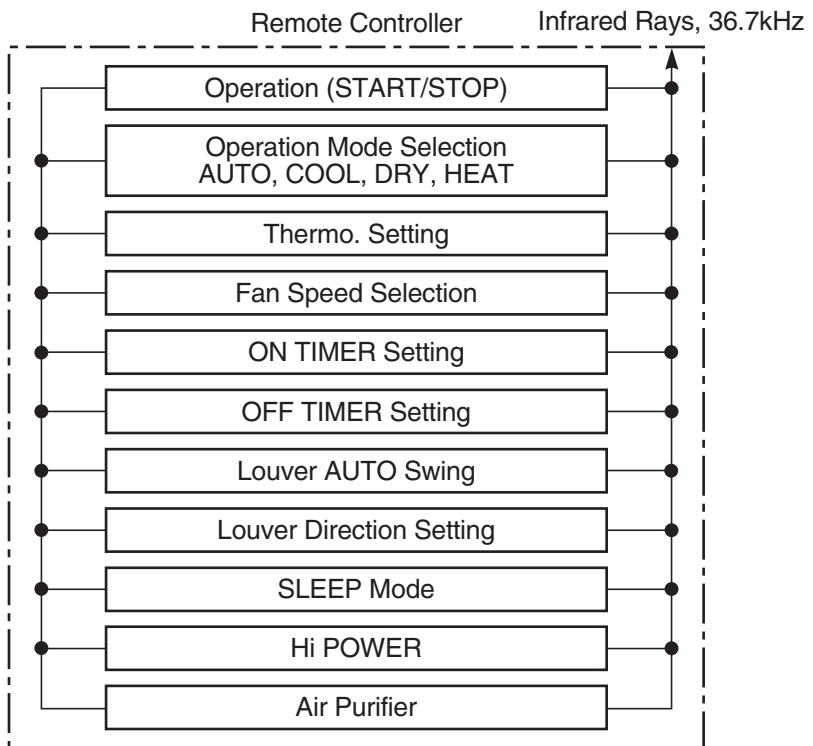

## 8-2. Outdoor Unit (Inverter Assembly)

RAS-5M34UAV-E

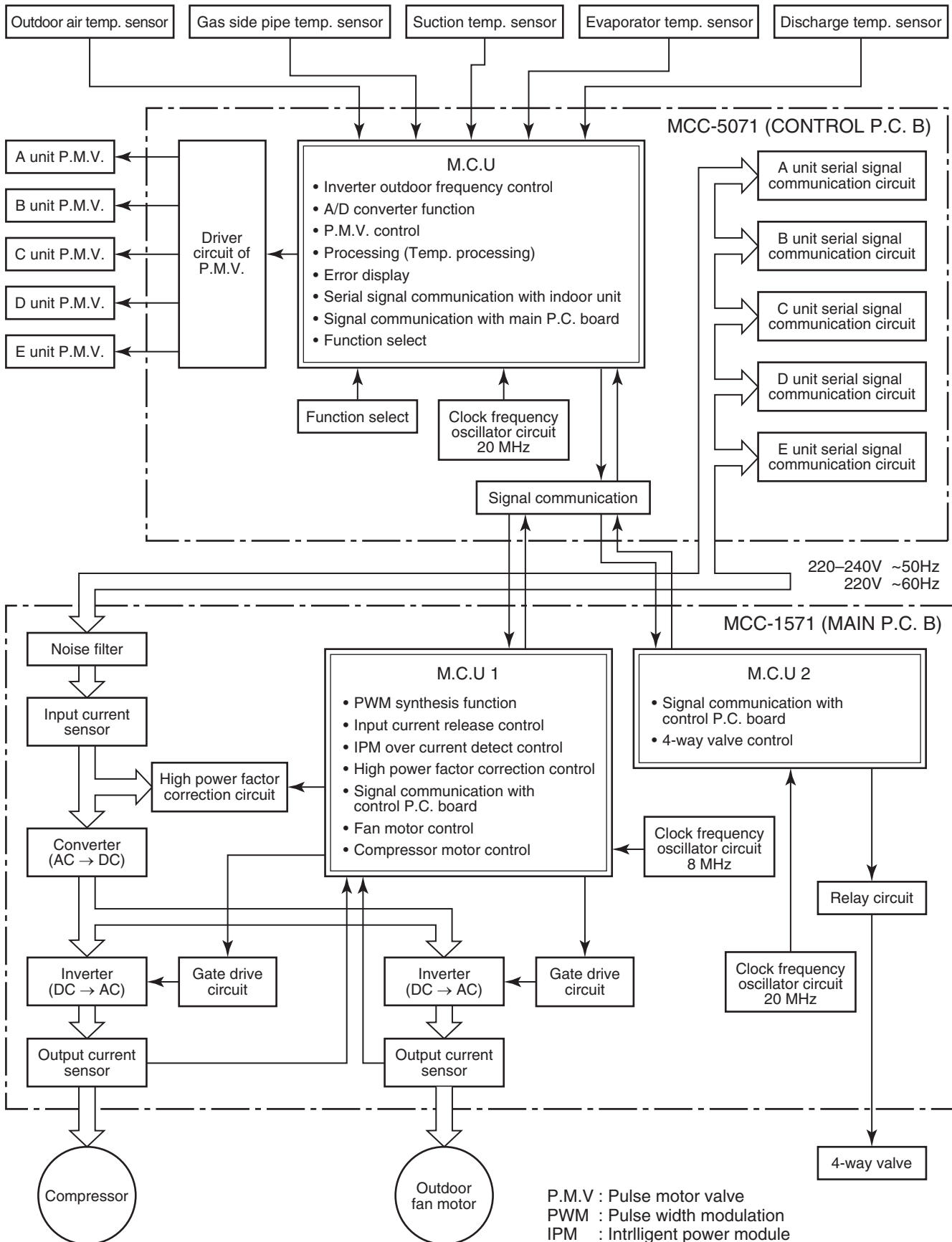

## 9. OPERATION DESCRIPTION

### 9-1. Outline of Air Conditioner Control

This air conditioner is a capacity-variable type air conditioner, which uses DC motor for the indoor fan motor and the outdoor fan motor. And the capacity-proportional control compressor which can change the motor speed in the range from 12 to 100 rps is mounted.

The DC motor drive circuit is mounted to the indoor unit. The compressor and the inverter to control fan motor are mounted to the outdoor unit.

The entire air conditioner is mainly controlled by the indoor unit controller.

The indoor unit controller drives the indoor fan motor based upon command sent from the remote controller, and transfers the operation command to the outdoor unit controller.

The outdoor unit controller receives operation command from the indoor unit side, and controls the outdoor fan and the pulse motor valve. (PMV)

Besides, detecting revolution position of the compressor motor, the outdoor unit controller controls speed of the compressor motor by controlling output voltage of the inverter and switching timing of the supply power (current transfer timing) so that motors drive according to the operation command.

And then, the outdoor unit controller transfers reversely the operating status information of the outdoor unit to control the indoor unit controller.

---

**As the compressor adopts four-pole brushless DC motor, the frequency of the supply power from inverter to compressor is two-times cycles of the actual number of revolution.**

---

#### 1. Role of indoor unit controller

The indoor unit controller judges the operation commands from the remote controller and assumes the following functions.

- Judgment of suction air temperature of the indoor heat exchanger by using the indoor temp. sensor. (TA sensor)
- Judgment of the indoor heat exchanger temperature by using heat exchanger sensor (TC sensor) (Prevent-freezing control, etc.)
- Louver motor control
- Indoor fan motor operation control
- LED (Light Emitting Diode) display control
- Transferring of operation command signal (Serial signal) to the outdoor unit
- Reception of information of operation status (Serial signal including outside temp. data) to the outdoor unit and judgment/display of error
- Air purifier operation control

#### 2. Role of outdoor unit controller

Receiving the operation command signal (Serial signal) from the indoor unit controller, the outdoor unit performs its role.

- Compressor operation control
  - Operation control of outdoor fan motor
  - P.M.V. control
  - 4-way valve control
- } Operations followed to judgment of serial signal from indoor side.

- Detection of inverter input current and current release operation
- Over-current detection and prevention operation to IGBT module (Compressor stop function)
- Compressor and outdoor fan stop function when serial signal is off (when the serial signal does not reach the board assembly of outdoor control by trouble of the signal system)
- Transferring of operation information (Serial signal) from outdoor unit controller to indoor unit controller
- Detection of outdoor temperature and operation revolution control
- Defrost control in heating operation (Temp. measurement by outdoor heat exchanger and control for 4-way valve and outdoor fan)

#### 3. Contents of operation command signal (Serial signal) from indoor unit controller to outdoor unit controller

The following three types of signals are sent from the indoor unit controller.

- Operation mode set on the remote controller
- Compressor revolution command signal defined by indoor temperature and set temperature (Correction along with variation of room temperature and correction of indoor heat exchanger temperature are added.)
- Temperature of indoor heat exchanger
- For these signals ([Operation mode] and [Compressor revolution] indoor heat exchanger temperature), the outdoor unit controller monitors the input current to the inverter, and performs the followed operation within the range that current does not exceed the allowable value.

#### 4. Contents of operation command signal (Serial signal) from outdoor unit controller to indoor unit controller

The following signals are sent from the outdoor unit controller.

- The current operation mode
  - The current compressor revolution
  - Outdoor temperature
  - Existence of protective circuit operation
- For transferring of these signals, the indoor unit controller monitors the contents of signals, and judges existence of trouble occurrence. Contents of judgment are described below.
- Whether distinction of the current operation status meets to the operation command signal
  - Whether protective circuit operates
- When no signal is received from the outdoor unit controller, it is assumed as a trouble.

## 9-2. Operation Description

1. Basic operation .....	50
1. Operation control .....	50
2. Operating mode selection when performing 2-room operation .....	51
3. Cooling/Heating operation .....	51
4. AUTO operation .....	52
5. DRY operation .....	52
2. Indoor fan motor control .....	53
<In cooling operation> .....	53
<In heating operation> (Heat pump model) .....	54
3. Outdoor fan motor control .....	56
4. Capacity control .....	57
5. Current release control .....	57
6. Release protective control by temperature of indoor heat exchanger .....	58
7. Winding/Coil heating control .....	59
8. Defrost control (Only in heating operation) .....	59
9. Compressor protective control .....	59
10. Louver control .....	60
1) Louver position .....	60
2) Air direction adjustment .....	60
3) Swing .....	60
11. SLEEP MODE operation .....	61
12. Temporary operation .....	62
13. Air purifying control .....	62
1. Purpose .....	62
2. Description .....	63
3. Operation .....	63
14. Discharge temperature control .....	64
15. Pulse motor valve (PMV) control .....	64
16. Clean operation .....	65
17. Clean operation cancel .....	66
18. Select switch on remote controller .....	67
19. Set temperature correction .....	68
20. Various setting on outdoor unit (Power save, Cooking-only, etc.) .....	68
<b>9-3. Auto Restart Function .....</b>	<b>69</b>
<b>9-3-1. Setting the Auto Restart Function .....</b>	<b>69</b>
<b>9-3-2. Cancel the Auto Restart Function .....</b>	<b>70</b>
<b>9-3-3. Power Failure During Timer Operation .....</b>	<b>70</b>
<b>9-4. Remote Controller and Its Functions .....</b>	<b>71</b>
<b>9-4-1. Parts Name of Remote Controller .....</b>	<b>71</b>
<b>9-4-2. Name and Functions of Indications on Remote Controller .....</b>	<b>72</b>
<b>9-5. Hi POWER Mode .....</b>	<b>73</b>
<b>9-6. Intermittent Operation Control for Indoor Fans of the Indoor Unit at Thermo-off Side in Heating Operation .....</b>	<b>73</b>

Item	Operation flow and applicable data, etc.	Description
1. Basic operation	<p><b>1. Operation control</b></p> <p>Receiving the user's operation condition setup, the operation statuses of indoor/outdoor units are controlled.</p> <ol style="list-style-type: none"> <li>1) The operation conditions are selected by the remote controller as shown in the below.</li> <li>2) A signal is sent by ON button of the remote controller.</li> <li>3) The signal is received by a sensor of the indoor unit and processed by the indoor controllers as shown in the below.</li> <li>4) The indoor controller controls the indoor fan motor and louver motor.</li> <li>5) The indoor controller sends the operation command to the outdoor controller, and sends/receives the control status with a serial signal.</li> <li>6) The outdoor controller controls the operation as shown in the below, and also controls the compressor, outdoor fan motor, 4-way valve and pulse motor valve.</li> </ol>	

**Remote controller**

  

**Indoor unit**







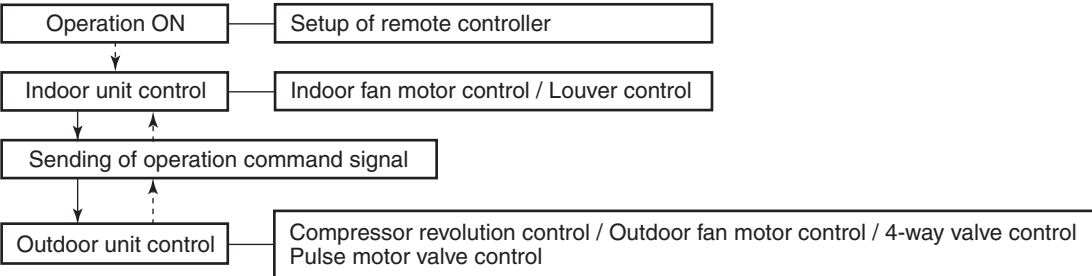

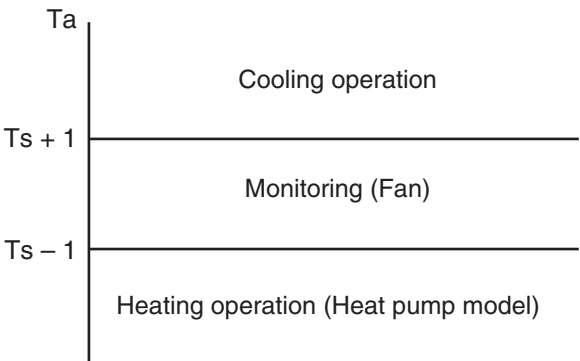
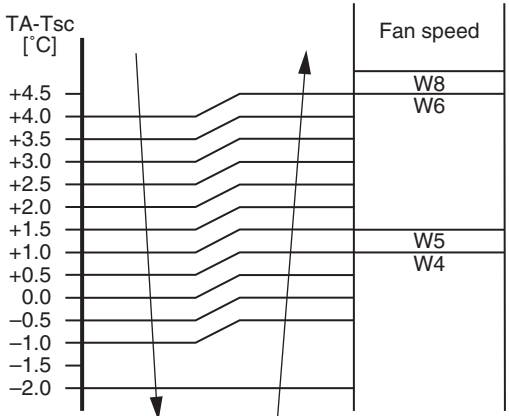

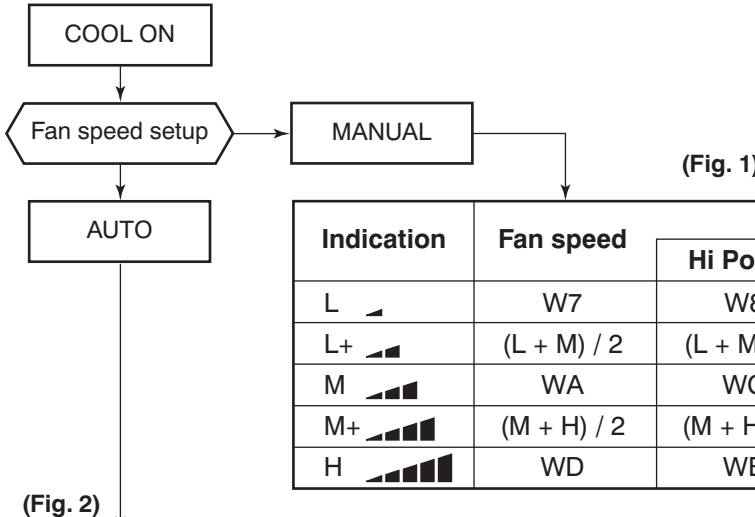





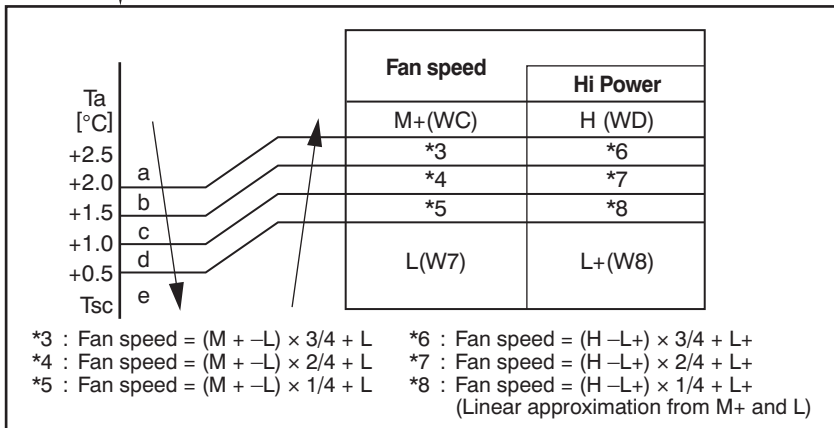

**Outdoor unit**



Item	Operation flow and applicable data, etc.	Description																																																																																																																																					
1. Basic operation	<p><b>2. Operating mode selection when performing 2-room operation</b></p> <p>1) The outdoor unit operating mode conforms to the instructions of the indoor unit that was pushed first.</p> <p>2) When combined operation consisting of cooling (dry) and heating, fan (air purification) and heating, or cleaning operation and heating is performed, operation conforms to the instructions of the indoor unit that was pushed first as shown in the following table.</p> <p>3) The indoor fan stops for the indoor unit that was pushed last and which instructions are ignored.</p> <p>4) When three or four indoor units are operated concurrently, the priority is also given to operating mode of the indoor unit which was pushed first as same as the case when two indoor units are operated concurrently.</p> <table border="1" data-bbox="331 504 1428 1413"> <thead> <tr> <th>No.</th> <th>Indoor unit</th> <th>Set operating mode</th> <th>Actual indoor unit operation</th> <th>Actual outdoor unit operation</th> </tr> </thead> <tbody> <tr> <td rowspan="2">1</td> <td>Pushed first</td> <td>Cooling (dry)</td> <td>Cooling (dry)</td> <td rowspan="2">Cooling</td> </tr> <tr> <td>Pushed last</td> <td>Cooling (dry)</td> <td>Cooling (dry)</td> </tr> <tr> <td rowspan="2">2</td> <td>Pushed first</td> <td>Heating</td> <td>Heating</td> <td rowspan="2">Heating</td> </tr> <tr> <td>Pushed last</td> <td>Heating</td> <td>Heating</td> </tr> <tr> <td rowspan="2">3</td> <td>Pushed first</td> <td>Fan (solo air purification)</td> <td>Fan (solo air purification)</td> <td rowspan="2">Stopped</td> </tr> <tr> <td>Pushed last</td> <td>Fan (solo air purification)</td> <td>Fan (solo air purification)</td> </tr> <tr> <td rowspan="2">4</td> <td>Pushed first</td> <td>Fan (solo air purification)</td> <td>Fan (solo air purification)</td> <td rowspan="2">Cooling</td> </tr> <tr> <td>Pushed last</td> <td>Cooling (dry)</td> <td>Cooling (dry)</td> </tr> <tr> <td rowspan="2">5</td> <td>Pushed first</td> <td>Cooling (dry)</td> <td>Cooling (dry)</td> <td rowspan="2">Cooling</td> </tr> <tr> <td>Pushed last</td> <td>Fan (solo air purification)</td> <td>Fan (solo air purification)</td> </tr> <tr> <td rowspan="2">6</td> <td>Pushed first</td> <td>Cooling (dry)</td> <td>Cooling (dry)</td> <td rowspan="2">Cooling</td> </tr> <tr> <td>Pushed last</td> <td>Heating</td> <td>Fan stopped</td> </tr> <tr> <td rowspan="2">7</td> <td>Pushed first</td> <td>Heating</td> <td>Heating</td> <td rowspan="2">Heating</td> </tr> <tr> <td>Pushed last</td> <td>Cooling (dry)</td> <td>Fan stopped</td> </tr> <tr> <td rowspan="2">8</td> <td>Pushed first</td> <td>Fan (solo air purification)</td> <td>Fan (solo air purification)</td> <td rowspan="2">Stopped</td> </tr> <tr> <td>Pushed last</td> <td>Heating</td> <td>Fan stopped</td> </tr> <tr> <td rowspan="2">9</td> <td>Pushed first</td> <td>Heating</td> <td>Heating</td> <td rowspan="2">Heating</td> </tr> <tr> <td>Pushed last</td> <td>Fan (solo air purification)</td> <td>Fan stopped</td> </tr> <tr> <td rowspan="2">10</td> <td>Pushed first</td> <td>Cleaning operation</td> <td>Cleaning operation</td> <td rowspan="2">Stopped</td> </tr> <tr> <td>Pushed last</td> <td>Cleaning operation</td> <td>Cleaning operation</td> </tr> <tr> <td rowspan="2">11</td> <td>Pushed first</td> <td>Cleaning operation</td> <td>Cleaning operation</td> <td rowspan="2">Cooling</td> </tr> <tr> <td>Pushed last</td> <td>Cooling (dry)</td> <td>Cooling (dry)</td> </tr> <tr> <td rowspan="2">12</td> <td>Pushed first</td> <td>Cooling (dry)</td> <td>Cooling (dry)</td> <td rowspan="2">Cooling</td> </tr> <tr> <td>Pushed last</td> <td>Cleaning operation</td> <td>Cleaning operation</td> </tr> <tr> <td rowspan="2">13</td> <td>Pushed first</td> <td>Cleaning operation</td> <td>Cleaning operation</td> <td rowspan="2">Stopped</td> </tr> <tr> <td>Pushed last</td> <td>Fan (solo air purification)</td> <td>Fan (solo air purification)</td> </tr> <tr> <td rowspan="2">14</td> <td>Pushed first</td> <td>Fan (solo air purification)</td> <td>Fan (solo air purification)</td> <td rowspan="2">Stopped</td> </tr> <tr> <td>Pushed last</td> <td>Cleaning operation</td> <td>Cleaning operation</td> </tr> <tr> <td rowspan="2">15</td> <td>Pushed first</td> <td>Cleaning operation</td> <td>Cleaning operation</td> <td rowspan="2">Stopped</td> </tr> <tr> <td>Pushed last</td> <td>Heating</td> <td>Fan stopped</td> </tr> <tr> <td rowspan="2">16</td> <td>Pushed first</td> <td>Heating</td> <td>Heating</td> <td rowspan="2">Heating</td> </tr> <tr> <td>Pushed last</td> <td>Cleaning operation</td> <td>Fan stopped</td> </tr> </tbody> </table>	No.	Indoor unit	Set operating mode	Actual indoor unit operation	Actual outdoor unit operation	1	Pushed first	Cooling (dry)	Cooling (dry)	Cooling	Pushed last	Cooling (dry)	Cooling (dry)	2	Pushed first	Heating	Heating	Heating	Pushed last	Heating	Heating	3	Pushed first	Fan (solo air purification)	Fan (solo air purification)	Stopped	Pushed last	Fan (solo air purification)	Fan (solo air purification)	4	Pushed first	Fan (solo air purification)	Fan (solo air purification)	Cooling	Pushed last	Cooling (dry)	Cooling (dry)	5	Pushed first	Cooling (dry)	Cooling (dry)	Cooling	Pushed last	Fan (solo air purification)	Fan (solo air purification)	6	Pushed first	Cooling (dry)	Cooling (dry)	Cooling	Pushed last	Heating	Fan stopped	7	Pushed first	Heating	Heating	Heating	Pushed last	Cooling (dry)	Fan stopped	8	Pushed first	Fan (solo air purification)	Fan (solo air purification)	Stopped	Pushed last	Heating	Fan stopped	9	Pushed first	Heating	Heating	Heating	Pushed last	Fan (solo air purification)	Fan stopped	10	Pushed first	Cleaning operation	Cleaning operation	Stopped	Pushed last	Cleaning operation	Cleaning operation	11	Pushed first	Cleaning operation	Cleaning operation	Cooling	Pushed last	Cooling (dry)	Cooling (dry)	12	Pushed first	Cooling (dry)	Cooling (dry)	Cooling	Pushed last	Cleaning operation	Cleaning operation	13	Pushed first	Cleaning operation	Cleaning operation	Stopped	Pushed last	Fan (solo air purification)	Fan (solo air purification)	14	Pushed first	Fan (solo air purification)	Fan (solo air purification)	Stopped	Pushed last	Cleaning operation	Cleaning operation	15	Pushed first	Cleaning operation	Cleaning operation	Stopped	Pushed last	Heating	Fan stopped	16	Pushed first	Heating	Heating	Heating	Pushed last	Cleaning operation	Fan stopped	
No.	Indoor unit	Set operating mode	Actual indoor unit operation	Actual outdoor unit operation																																																																																																																																			
1	Pushed first	Cooling (dry)	Cooling (dry)	Cooling																																																																																																																																			
	Pushed last	Cooling (dry)	Cooling (dry)																																																																																																																																				
2	Pushed first	Heating	Heating	Heating																																																																																																																																			
	Pushed last	Heating	Heating																																																																																																																																				
3	Pushed first	Fan (solo air purification)	Fan (solo air purification)	Stopped																																																																																																																																			
	Pushed last	Fan (solo air purification)	Fan (solo air purification)																																																																																																																																				
4	Pushed first	Fan (solo air purification)	Fan (solo air purification)	Cooling																																																																																																																																			
	Pushed last	Cooling (dry)	Cooling (dry)																																																																																																																																				
5	Pushed first	Cooling (dry)	Cooling (dry)	Cooling																																																																																																																																			
	Pushed last	Fan (solo air purification)	Fan (solo air purification)																																																																																																																																				
6	Pushed first	Cooling (dry)	Cooling (dry)	Cooling																																																																																																																																			
	Pushed last	Heating	Fan stopped																																																																																																																																				
7	Pushed first	Heating	Heating	Heating																																																																																																																																			
	Pushed last	Cooling (dry)	Fan stopped																																																																																																																																				
8	Pushed first	Fan (solo air purification)	Fan (solo air purification)	Stopped																																																																																																																																			
	Pushed last	Heating	Fan stopped																																																																																																																																				
9	Pushed first	Heating	Heating	Heating																																																																																																																																			
	Pushed last	Fan (solo air purification)	Fan stopped																																																																																																																																				
10	Pushed first	Cleaning operation	Cleaning operation	Stopped																																																																																																																																			
	Pushed last	Cleaning operation	Cleaning operation																																																																																																																																				
11	Pushed first	Cleaning operation	Cleaning operation	Cooling																																																																																																																																			
	Pushed last	Cooling (dry)	Cooling (dry)																																																																																																																																				
12	Pushed first	Cooling (dry)	Cooling (dry)	Cooling																																																																																																																																			
	Pushed last	Cleaning operation	Cleaning operation																																																																																																																																				
13	Pushed first	Cleaning operation	Cleaning operation	Stopped																																																																																																																																			
	Pushed last	Fan (solo air purification)	Fan (solo air purification)																																																																																																																																				
14	Pushed first	Fan (solo air purification)	Fan (solo air purification)	Stopped																																																																																																																																			
	Pushed last	Cleaning operation	Cleaning operation																																																																																																																																				
15	Pushed first	Cleaning operation	Cleaning operation	Stopped																																																																																																																																			
	Pushed last	Heating	Fan stopped																																																																																																																																				
16	Pushed first	Heating	Heating	Heating																																																																																																																																			
	Pushed last	Cleaning operation	Fan stopped																																																																																																																																				
	<p><b>3. Cooling/Heating operation</b></p> <p>The operations are performed in the following parts by controls according to cooling/heating conditions.</p> <p>1) Receiving the operation ON signal of the remote controller, the cooling or heating operation signal starts being transferred from the indoor controller to the outdoor unit.</p> <p>2) At the indoor unit side, the indoor fan is operated according to the contents of “<b>2. Indoor fan motor control</b>” and the louver according to the contents of “<b>10. Louver control</b>”, respectively.</p> <p>3) The outdoor unit controls the outdoor fan motor, compressor, pulse motor valve (PMV) and 4-way valve according to the operation signal sent from the indoor unit.</p> <p>*1. The relay of 4-way valve is turned on, for a few seconds when 4-way valve is driven.</p>  <pre> graph TD     A[Operation ON] --&gt; B[Indoor unit control]     C[Setup of remote controller] --- A     B --&gt; D[Sending of operation command signal]     D --&gt; E[Outdoor unit control]     E --&gt; B     F[Indoor fan motor control / Louver control] --- B     G[Compressor revolution control / Outdoor fan motor control / 4-way valve control / Pulse motor valve control] --- E   </pre>																																																																																																																																						

Item	Operation flow and applicable data, etc.	Description
1. Basic operation	<p><b>4. AUTO operation</b></p> <p>Selection of operation mode As shown in the following figure, the operation starts by selecting automatically the status of room temperature (Ta) when starting AUTO operation.</p>  <p>*1. When reselecting the operation mode, the fan speed is controlled by the previous operation mode.</p>	<ol style="list-style-type: none"> <li>1) Detects the room temperature (Ta) when the operation started.</li> <li>2) Selects an operation mode from Ta in the left figure.</li> <li>3) Fan operation continues until an operation mode is selected.</li> <li>4) When AUTO operation has started within 2 hours after heating operation stopped and if the room temperature is 20°C or more, the fan operation is performed with "Super Ultra LOW" mode for 3 minutes. Then, select an operation mode.</li> <li>5) If the status of compressor-OFF continues for 15 minutes the room temperature after selecting an operation mode (COOL/HEAT), reselect an operation mode.</li> </ol>
	<p><b>5. DRY operation</b></p> <p>DRY operation is performed according to the difference between room temperature and the setup temperature as shown below.</p> <p>In DRY operation, fan speed is controlled in order to prevent lowering of the room temperature.</p> 	<ol style="list-style-type: none"> <li>1) Detects the room temperature (Ta) when the DRY operation started.</li> <li>2) Starts operation under conditions in the left figure according to the temperature difference between the room temperature and the setup temperature (Tsc). Setup temperature (Tsc) = Set temperature on remote controller (Ts) + (-1.5 to 2.0)</li> <li>3) When the room temperature is lower 2°C or less than the setup temperature, turn off the compressor.</li> </ol>

Item	Operation flow and applicable data, etc.	Description																																						
2. Indoor fan motor control	<p><b>&lt;In cooling operation&gt;</b> (This operation controls the fan speed at indoor unit side.) The indoor fan (cross flow fan) is operated by the phase control induction motor. The fan rotates in 5 stages in MANUAL mode, and in 5 stages in AUTO mode, respectively. (Table 1)</p>  <p>(Fig. 1)</p> <table border="1"> <thead> <tr> <th rowspan="2">Indication</th> <th colspan="2">Fan speed</th> </tr> <tr> <th></th> <th>Hi Power</th> </tr> </thead> <tbody> <tr> <td>L </td> <td>W7</td> <td>W8</td> </tr> <tr> <td>L+ </td> <td><math>(L + M) / 2</math></td> <td><math>(L + M) / 2</math></td> </tr> <tr> <td>M </td> <td>WA</td> <td>WC</td> </tr> <tr> <td>M+ </td> <td><math>(M + H) / 2</math></td> <td><math>(M + H) / 2</math></td> </tr> <tr> <td>H </td> <td>WD</td> <td>WE</td> </tr> </tbody> </table> <p>(Fig. 2)</p>  <p>(Fig. 2)</p> <table border="1"> <thead> <tr> <th colspan="2">Fan speed</th> <th>Hi Power</th> </tr> </thead> <tbody> <tr> <td>M+(WC)</td> <td></td> <td>H (WD)</td> </tr> <tr> <td>*3</td> <td></td> <td>*6</td> </tr> <tr> <td>*4</td> <td></td> <td>*7</td> </tr> <tr> <td>*5</td> <td></td> <td>*8</td> </tr> <tr> <td>L(W7)</td> <td></td> <td>L+(W8)</td> </tr> </tbody> </table> <p>*3 : Fan speed = <math>(M + -L) \times 3/4 + L</math>      *6 : Fan speed = <math>(H - L+) \times 3/4 + L+</math>  *4 : Fan speed = <math>(M + -L) \times 2/4 + L</math>      *7 : Fan speed = <math>(H - L+) \times 2/4 + L+</math>  *5 : Fan speed = <math>(M + -L) \times 1/4 + L</math>      *8 : Fan speed = <math>(H - L+) \times 1/4 + L+</math>  (Linear approximation from M+ and L)</p>	Indication	Fan speed			Hi Power	L 	W7	W8	L+ 	$(L + M) / 2$	$(L + M) / 2$	M 	WA	WC	M+ 	$(M + H) / 2$	$(M + H) / 2$	H 	WD	WE	Fan speed		Hi Power	M+(WC)		H (WD)	*3		*6	*4		*7	*5		*8	L(W7)		L+(W8)	<p><b>* Symbols</b></p> <p>UH : Ultra High  H : High  M+ : Medium+  M : Medium  L+ : Low+  L : Low  L- : Low-  UL : Ultra Low  SUL : Super Ultra Low</p> <p>* The fan speed broadly varies due to position of the louver, etc.  The described value indicates one under condition of inclining downward blowing.</p> <ol style="list-style-type: none"> <li>1) When setting the fan speed to L, L+, M, M+ or H on the remote controller, the operation is performed with the constant speed shown in Fig. 1.</li> <li>2) When the fan speed mode is manual and <math>T_a &lt; 22^\circ\text{C}</math> and the compressor stops, the fan speed is controlled from W2 (20 seconds) to 0 rpm (40 seconds).</li> <li>3) When setting the fan speed to AUTO on the remote controller, revolution of the fan motor is controlled to the fan speed level shown in Fig. 2 and Table 1 according to the setup temperature, room temperature, and heat exchanger temperature.</li> <li>4) When the fan speed mode is AUTO and the compressor stops, the fan speed is controlled from W2 (20 seconds) to 0 rpm (40 seconds).</li> </ol>
Indication	Fan speed																																							
		Hi Power																																						
L 	W7	W8																																						
L+ 	$(L + M) / 2$	$(L + M) / 2$																																						
M 	WA	WC																																						
M+ 	$(M + H) / 2$	$(M + H) / 2$																																						
H 	WD	WE																																						
Fan speed		Hi Power																																						
M+(WC)		H (WD)																																						
*3		*6																																						
*4		*7																																						
*5		*8																																						
L(W7)		L+(W8)																																						
<b>(Table 1) Indoor fan air flow rate (Cooling, Dry)</b>																																								
Fan speed level	RAS-M10PKVP-E		RAS-M13PKVP-E		RAS-M16PKVP-E		RAS-M18PKVP-E																																	
	Fan speed (rpm)	Air flow rate (m <sup>3</sup> /h)	Fan speed (rpm)	Air flow rate (m <sup>3</sup> /h)	Fan speed (rpm)	Air flow rate (m <sup>3</sup> /h)	Fan speed (rpm)	Air flow rate (m <sup>3</sup> /h)																																
WF		1200	690	1260	730	1340	790	1450	845																															
WE	UH	1200	690	1260	730	1340	790	1450	845																															
WD	H	1140	640	1210	690	1280	750	1390	805																															
WC	M+	1080	600	1130	640	1200	690	1310	745																															
WB		1020	560	1060	590	1120	630	1220	680																															
WA	M	960	510	990	530	1040	570	1130	620																															
W9		910	480	930	490	980	530	1070	575																															
W8	L+	850	430	870	450	930	490	1000	525																															
W7	L	790	390	810	400	880	450	930	475																															
W6	L-	770	370	770	370	770	370	800	380																															
W5	UL	700	320	700	320	700	320	700	310																															
W4		650	290	650	290	650	290	650	275																															
W3	SUL	600	250	600	250	600	250	600	240																															
W2		600	250	600	250	600	250	600	240																															
W1		520	190	520	190	520	190	520	185																															

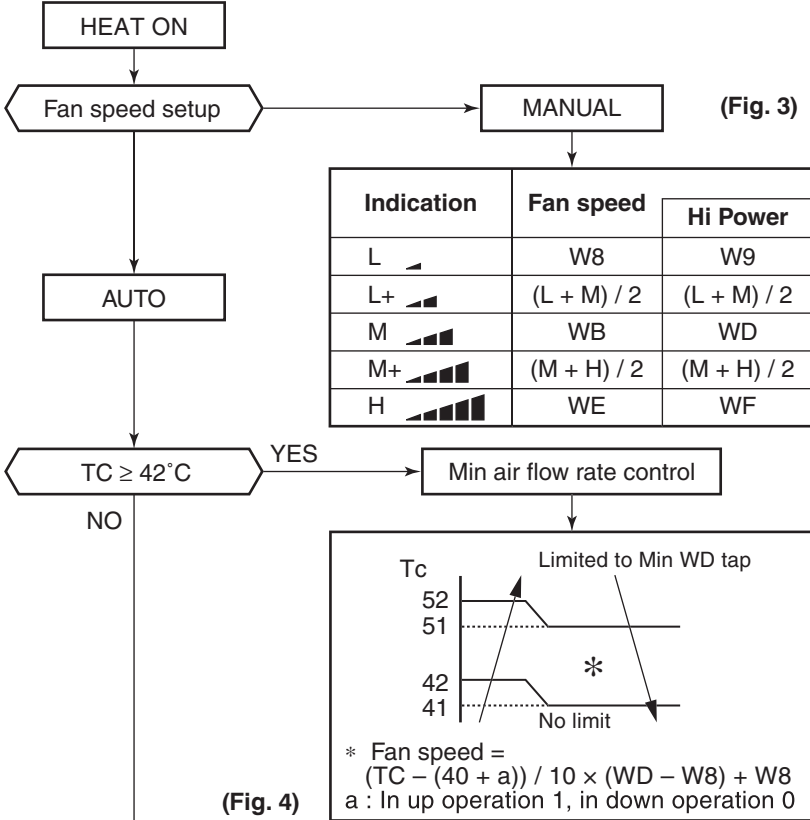
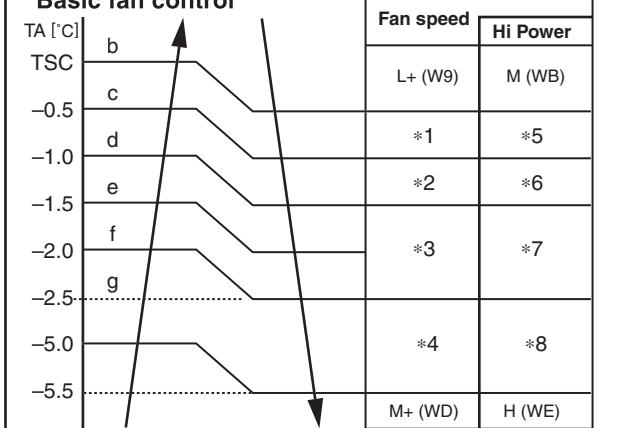
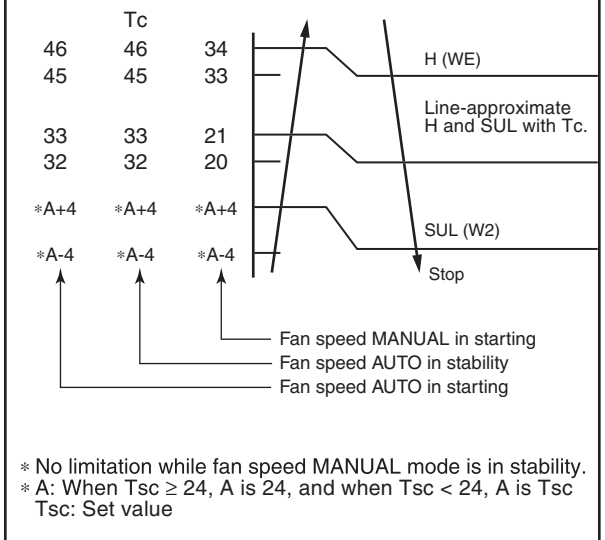
Item	Operation flow and applicable data, etc.	Description																		
<p>2. Indoor fan motor control (Continued)</p>	<p><b>&lt;In heating operation&gt; (Heat pump model)</b>            (This operation controls the fan speed at indoor unit side.)            The indoor fan (cross flow fan) is operated by the phase control induction motor.            The fan rotates in 5 stages in MANUAL mode, and in 5 stages in AUTO mode, respectively. (Table 2)</p>  <p>(Fig. 3)</p> <table border="1" data-bbox="496 600 981 857"> <thead> <tr> <th>Indication</th> <th>Fan speed</th> <th>Hi Power</th> </tr> </thead> <tbody> <tr> <td>L</td> <td>W8</td> <td>W9</td> </tr> <tr> <td>L+</td> <td>(L + M) / 2</td> <td>(L + M) / 2</td> </tr> <tr> <td>M</td> <td>WB</td> <td>WD</td> </tr> <tr> <td>M+</td> <td>(M + H) / 2</td> <td>(M + H) / 2</td> </tr> <tr> <td>H</td> <td>WE</td> <td>WF</td> </tr> </tbody> </table> <p>(Fig. 4)</p>	Indication	Fan speed	Hi Power	L	W8	W9	L+	(L + M) / 2	(L + M) / 2	M	WB	WD	M+	(M + H) / 2	(M + H) / 2	H	WE	WF	<ol style="list-style-type: none"> <li>When setting the fan speed to L, L+, M, M+ or H on the remote controller, the operation is performed with the constant speed shown in Fig. 3 and Table 2.</li> <li>When setting the fan speed to AUTO on the remote controller, revolution of the fan motor is controlled to the fan speed level shown in Fig. 5 according to the set temperature and room temperature.</li> <li>Min air flow rate is controlled by temperature of the indoor heat exchanger (Tc) as shown in Fig. 4.</li> <li>Cold draft prevention, the fan speed is controlled by temperature of the indoor heat exchanger (Tc) as shown in Fig. 6.</li> </ol>
Indication	Fan speed	Hi Power																		
L	W8	W9																		
L+	(L + M) / 2	(L + M) / 2																		
M	WB	WD																		
M+	(M + H) / 2	(M + H) / 2																		
H	WE	WF																		
	<p><b>Basic fan control</b></p>  <table border="1" data-bbox="534 1310 758 1736"> <thead> <tr> <th>Fan speed</th> <th>Hi Power</th> </tr> </thead> <tbody> <tr> <td>L+ (W9)</td> <td>M (WB)</td> </tr> <tr> <td>*1</td> <td>*5</td> </tr> <tr> <td>*2</td> <td>*6</td> </tr> <tr> <td>*3</td> <td>*7</td> </tr> <tr> <td>*4</td> <td>*8</td> </tr> <tr> <td>M+ (WD)</td> <td>H (WE)</td> </tr> </tbody> </table> <p>(Fig. 5)</p>	Fan speed	Hi Power	L+ (W9)	M (WB)	*1	*5	*2	*6	*3	*7	*4	*8	M+ (WD)	H (WE)	<p><b>Cold draft preventive control</b></p>  <p>(Fig. 6)</p>				
Fan speed	Hi Power																			
L+ (W9)	M (WB)																			
*1	*5																			
*2	*6																			
*3	*7																			
*4	*8																			
M+ (WD)	H (WE)																			

Item	Operation flow and applicable data, etc.	Description
2. Indoor fan motor control (Continued)		

**[In starting and in stability]**

	In starting	In stability
FAN AUTO	<ul style="list-style-type: none"> <li>• Until 12 minutes passed after operation start</li> <li>• When 12 to 25 minutes passed after operation start and room temp. is 3°C or lower than set temp.</li> </ul>	<ul style="list-style-type: none"> <li>• When 12 to 25 minutes passed after operation start and room temp. is higher than (set temp. -3°C)</li> <li>• When 25 minutes or more passed after operation start</li> </ul>
FAN Manual	<ul style="list-style-type: none"> <li>• Room temp. &lt; Set temp. -4°C</li> </ul>	<ul style="list-style-type: none"> <li>• Room temp. ≥ Set temp. -3.5°C</li> </ul>

**(Table 2) Indoor fan air flow rate (Heating)**

Fan speed level		RAS-M10PKVP-E		RAS-M13PKVP-E		RAS-M16PKVP-E		RAS-M18PKVP-E	
		Fan speed (rpm)	Air flow rate (m³/h)	Fan speed (rpm)	Air flow rate (m³/h)	Fan speed (rpm)	Air flow rate (m³/h)	Fan speed (rpm)	Air flow rate (m³/h)
WF		1140	640	1200	690	1280	750	1390	805
WE	UH	1140	640	1200	690	1280	750	1390	805
WD	H	1070	590	1100	610	1180	670	1290	730
WC	M+	980	530	1010	550	1090	610	1180	655
WB		900	470	930	490	980	530	1070	575
WA	M	850	430	850	430	900	470	980	510
W9		810	400	810	400	880	450	950	490
W8	L+	710	330	710	330	780	380	850	420
W7	L	710	330	710	330	710	330	850	420
W6	L-	650	290	650	290	700	320	700	310
W5	UL	650	290	650	290	650	290	650	275
W4		650	290	650	290	650	290	650	275
W3	SUL	650	290	650	290	650	290	650	275
W2		560	220	560	220	560	220	560	210
W1		420	120	420	120	420	120	420	110



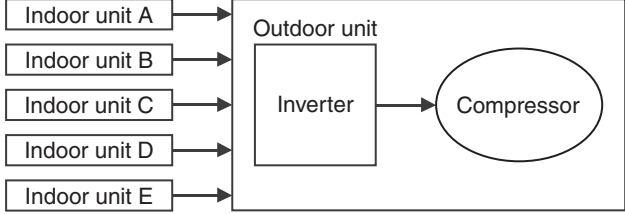
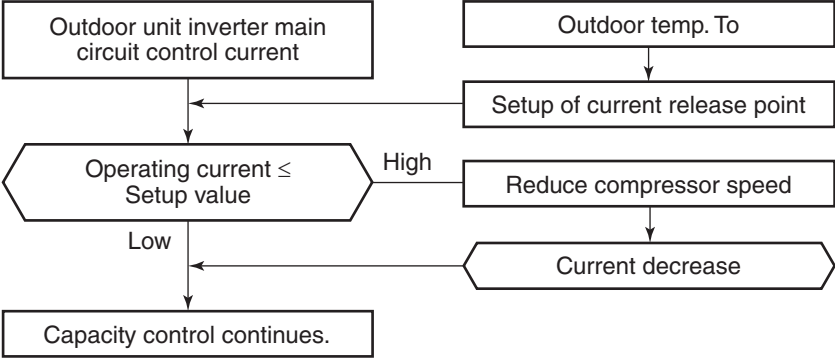





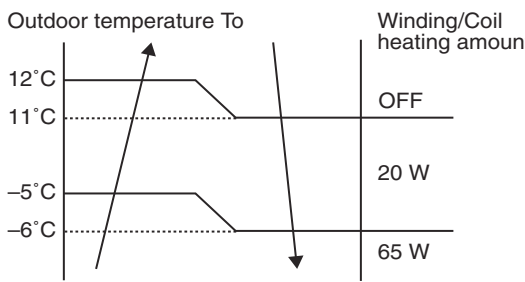
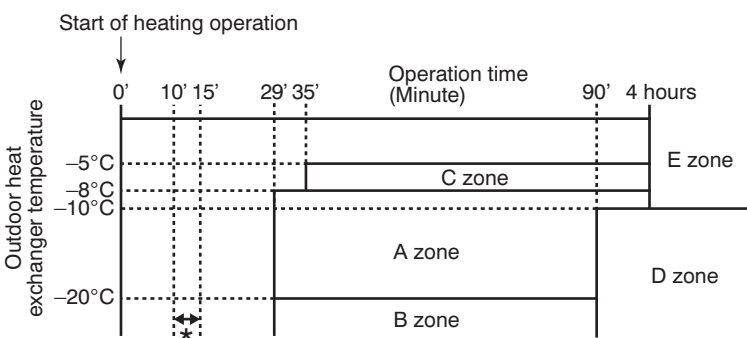







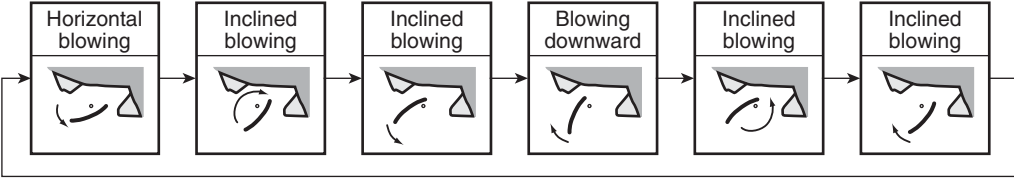



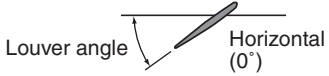

Item	Operation flow and applicable data, etc.	Description																																							
3. Outdoor fan motor control	<p>The blowing air volume at the outdoor unit side is controlled. Receiving the operation command from the controller of indoor unit, the controller of outdoor unit controls fan speed.</p> <p>* For the fan motor, a DC motor with non-stage variable speed system is used. However, it is limited to 8 stages for reasons of controlling.</p>	<ol style="list-style-type: none"> <li>1) The operation command sent from the remote controller is processed by the indoor unit controller and transferred to the controller of the outdoor unit.</li> <li>2) When strong wind blows at outdoor side, the operation of air conditioner continues with the fan motor stopped.</li> <li>3) Whether the fan is locked or not is detected, and the operation of air conditioner stops and an alarm is displayed if the fan is locked.</li> <li>4) According to each operation mode, by the conditions of outdoor temperature (To) and compressor revolution, the speed of the outdoor fan shown in the table is selected.</li> </ol>																																							
<b>Cooling operation, dry operation</b>																																									
<table border="1" style="width: 100%; border-collapse: collapse;"> <thead> <tr> <th colspan="2" style="text-align: center;">Compressor revolution (rps)</th> <th style="text-align: center;">~16.8</th> <th style="text-align: center;">~41.3</th> <th style="text-align: center;">~51.5</th> <th style="text-align: center;">51.5~</th> </tr> </thead> <tbody> <tr> <td rowspan="3" style="text-align: center;">Outdoor temp. sensor TO</td> <td style="text-align: center;">TO ≥ 38°C</td> <td style="text-align: center;">450 (rpm)</td> <td style="text-align: center;">650 (rpm)</td> <td style="text-align: center;">730 (rpm)</td> <td style="text-align: center;">730 (rpm)</td> </tr> <tr> <td rowspan="2" style="text-align: center;">TO &lt; 38°C</td> <td style="text-align: center;">1 to 2 units</td> <td style="text-align: center;">450 (rpm)</td> <td style="text-align: center;">650 (rpm)</td> <td style="text-align: center;">730 (rpm)</td> </tr> <tr> <td style="text-align: center;">1 to 2 units</td> <td style="text-align: center;">450 (rpm)</td> <td style="text-align: center;">650 (rpm)</td> <td style="text-align: center;">650 (rpm)</td> <td style="text-align: center;">730 (rpm)</td> </tr> <tr> <td rowspan="2" style="text-align: center;">Sleep operation</td> <td style="text-align: center;">TO ≥ 38°C</td> <td style="text-align: center;">450 (rpm)</td> <td style="text-align: center;">650 (rpm)</td> <td style="text-align: center;">650 (rpm)</td> <td style="text-align: center;">730 (rpm)</td> </tr> <tr> <td style="text-align: center;">TO &lt; 38°C</td> <td style="text-align: center;">450 (rpm)</td> <td style="text-align: center;">650 (rpm)</td> <td style="text-align: center;">650 (rpm)</td> <td style="text-align: center;">650 (rpm)</td> </tr> <tr> <td colspan="2" style="text-align: center;">TO is abnormal</td> <td style="text-align: center;">450 (rpm)</td> <td style="text-align: center;">650 (rpm)</td> <td style="text-align: center;">730 (rpm)</td> <td style="text-align: center;">730 (rpm)</td> </tr> </tbody> </table>			Compressor revolution (rps)		~16.8	~41.3	~51.5	51.5~	Outdoor temp. sensor TO	TO ≥ 38°C	450 (rpm)	650 (rpm)	730 (rpm)	730 (rpm)	TO < 38°C	1 to 2 units	450 (rpm)	650 (rpm)	730 (rpm)	1 to 2 units	450 (rpm)	650 (rpm)	650 (rpm)	730 (rpm)	Sleep operation	TO ≥ 38°C	450 (rpm)	650 (rpm)	650 (rpm)	730 (rpm)	TO < 38°C	450 (rpm)	650 (rpm)	650 (rpm)	650 (rpm)	TO is abnormal		450 (rpm)	650 (rpm)	730 (rpm)	730 (rpm)
Compressor revolution (rps)		~16.8	~41.3	~51.5	51.5~																																				
Outdoor temp. sensor TO	TO ≥ 38°C	450 (rpm)	650 (rpm)	730 (rpm)	730 (rpm)																																				
	TO < 38°C	1 to 2 units	450 (rpm)	650 (rpm)	730 (rpm)																																				
		1 to 2 units	450 (rpm)	650 (rpm)	650 (rpm)	730 (rpm)																																			
Sleep operation	TO ≥ 38°C	450 (rpm)	650 (rpm)	650 (rpm)	730 (rpm)																																				
	TO < 38°C	450 (rpm)	650 (rpm)	650 (rpm)	650 (rpm)																																				
TO is abnormal		450 (rpm)	650 (rpm)	730 (rpm)	730 (rpm)																																				
TO : Outdoor temp. sensor																																									
<b>Heating operation</b>																																									
<table border="1" style="width: 100%; border-collapse: collapse;"> <thead> <tr> <th colspan="2" style="text-align: center;">Compressor revolution (rps)</th> <th style="text-align: center;">16.8</th> <th style="text-align: center;">~27.5</th> <th style="text-align: center;">27.5~</th> </tr> </thead> <tbody> <tr> <td rowspan="3" style="text-align: center;">Outdoor temp. sensor TO</td> <td style="text-align: center;">TO &gt; 10°C</td> <td style="text-align: center;">390 (rpm)</td> <td style="text-align: center;">650 (rpm)</td> <td style="text-align: center;">650 (rpm)</td> </tr> <tr> <td style="text-align: center;">TO ≤ 10°C</td> <td style="text-align: center;">500 (rpm)</td> <td style="text-align: center;">650 (rpm)</td> <td style="text-align: center;">790 (rpm)</td> </tr> <tr> <td style="text-align: center;">TO ≤ 5°C</td> <td style="text-align: center;">650 (rpm)</td> <td style="text-align: center;">790 (rpm)</td> <td style="text-align: center;">850 (rpm)</td> </tr> <tr> <td rowspan="3" style="text-align: center;">Sleep operation</td> <td style="text-align: center;">TO &gt; 10°C</td> <td style="text-align: center;">390 (rpm)</td> <td style="text-align: center;">500 (rpm)</td> <td style="text-align: center;">650 (rpm)</td> </tr> <tr> <td style="text-align: center;">TO ≤ 10°C</td> <td style="text-align: center;">390 (rpm)</td> <td style="text-align: center;">650 (rpm)</td> <td style="text-align: center;">650 (rpm)</td> </tr> <tr> <td style="text-align: center;">TO ≤ 5°C</td> <td style="text-align: center;">390 (rpm)</td> <td style="text-align: center;">650 (rpm)</td> <td style="text-align: center;">650 (rpm)</td> </tr> <tr> <td colspan="2" style="text-align: center;">TO is abnormal</td> <td style="text-align: center;">390 (rpm)</td> <td style="text-align: center;">650 (rpm)</td> <td style="text-align: center;">790 (rpm)</td> </tr> </tbody> </table>			Compressor revolution (rps)		16.8	~27.5	27.5~	Outdoor temp. sensor TO	TO > 10°C	390 (rpm)	650 (rpm)	650 (rpm)	TO ≤ 10°C	500 (rpm)	650 (rpm)	790 (rpm)	TO ≤ 5°C	650 (rpm)	790 (rpm)	850 (rpm)	Sleep operation	TO > 10°C	390 (rpm)	500 (rpm)	650 (rpm)	TO ≤ 10°C	390 (rpm)	650 (rpm)	650 (rpm)	TO ≤ 5°C	390 (rpm)	650 (rpm)	650 (rpm)	TO is abnormal		390 (rpm)	650 (rpm)	790 (rpm)			
Compressor revolution (rps)		16.8	~27.5	27.5~																																					
Outdoor temp. sensor TO	TO > 10°C	390 (rpm)	650 (rpm)	650 (rpm)																																					
	TO ≤ 10°C	500 (rpm)	650 (rpm)	790 (rpm)																																					
	TO ≤ 5°C	650 (rpm)	790 (rpm)	850 (rpm)																																					
Sleep operation	TO > 10°C	390 (rpm)	500 (rpm)	650 (rpm)																																					
	TO ≤ 10°C	390 (rpm)	650 (rpm)	650 (rpm)																																					
	TO ≤ 5°C	390 (rpm)	650 (rpm)	650 (rpm)																																					
TO is abnormal		390 (rpm)	650 (rpm)	790 (rpm)																																					
TO : Outdoor temp. sensor																																									

Item	Operation flow and applicable data, etc.	Description																																																																																				
4. Capacity control	<p>1) Four indoor units from A to E determine the respective instruction revolutions from the difference between the remote controller setting temperature (Ts) and the indoor temperature (Ta), and transmit this to the outdoor unit.</p> <p>2) The outdoor unit receives the instructions from the indoor units, and the inverter operates the compressor at the calculated revolutions.</p> <p>3) The compressor operation range in each operating mode is shown in the left table.</p> 																																																																																					
<table border="1"> <thead> <tr> <th>Operation mode</th> <th>No. of operating unit</th> <th>Combination of indoor units</th> <th>Compressor revolution (rps)</th> </tr> </thead> <tbody> <tr> <td rowspan="10">COOL</td> <td rowspan="5">1 unit</td> <td>M07</td> <td>12 to 22.1</td> </tr> <tr> <td>M10</td> <td>12 to 22.1</td> </tr> <tr> <td>M13</td> <td>12 to 34.1</td> </tr> <tr> <td>M16</td> <td>12 to 43.1</td> </tr> <tr> <td>M18</td> <td>12 to 44.9</td> </tr> <tr> <td>2 units</td> <td>○ *</td> <td>12 to 53.3</td> </tr> <tr> <td>3 units</td> <td>○ *</td> <td>24.5 to 56.2</td> </tr> <tr> <td>4 units</td> <td>○ *</td> <td>24.5 to 56.2</td> </tr> <tr> <td>5 units</td> <td>○ *</td> <td>24.5 to 80.2</td> </tr> </tbody> </table>	Operation mode	No. of operating unit	Combination of indoor units	Compressor revolution (rps)	COOL	1 unit	M07	12 to 22.1	M10	12 to 22.1	M13	12 to 34.1	M16	12 to 43.1	M18	12 to 44.9	2 units	○ *	12 to 53.3	3 units	○ *	24.5 to 56.2	4 units	○ *	24.5 to 56.2	5 units	○ *	24.5 to 80.2	<table border="1"> <thead> <tr> <th>Operation mode</th> <th>No. of operating unit</th> <th>Combination of indoor units</th> <th>Compressor revolution (rps)</th> </tr> </thead> <tbody> <tr> <td rowspan="10">HEAT</td> <td rowspan="5">1 unit</td> <td>M07</td> <td>12 to 42.5</td> </tr> <tr> <td>M10</td> <td>12 to 42.5</td> </tr> <tr> <td>M13</td> <td>12 to 51.5</td> </tr> <tr> <td>M16</td> <td>12 to 54.4</td> </tr> <tr> <td>M18</td> <td>12 to 69.4</td> </tr> <tr> <td>2 units</td> <td>○ *</td> <td>12 to 73.6</td> </tr> <tr> <td>3 units</td> <td>○ *</td> <td>14.4 to 73.6</td> </tr> <tr> <td>4 units</td> <td>○ *</td> <td>18.0 to 73.6</td> </tr> <tr> <td>5 units</td> <td>○ *</td> <td>18.0 to 100.5</td> </tr> </tbody> </table>	Operation mode	No. of operating unit	Combination of indoor units	Compressor revolution (rps)	HEAT	1 unit	M07	12 to 42.5	M10	12 to 42.5	M13	12 to 51.5	M16	12 to 54.4	M18	12 to 69.4	2 units	○ *	12 to 73.6	3 units	○ *	14.4 to 73.6	4 units	○ *	18.0 to 73.6	5 units	○ *	18.0 to 100.5	<table border="1"> <thead> <tr> <th>Operation mode</th> <th>No. of operating unit</th> <th>Combination of indoor units</th> <th>Compressor revolution (rps)</th> </tr> </thead> <tbody> <tr> <td rowspan="10">HEAT</td> <td rowspan="5">1 unit</td> <td>M07</td> <td>12 to 42.5</td> </tr> <tr> <td>M10</td> <td>12 to 42.5</td> </tr> <tr> <td>M13</td> <td>12 to 51.5</td> </tr> <tr> <td>M16</td> <td>12 to 54.4</td> </tr> <tr> <td>M18</td> <td>12 to 69.4</td> </tr> <tr> <td>2 units</td> <td>○ *</td> <td>12 to 73.6</td> </tr> <tr> <td>3 units</td> <td>○ *</td> <td>14.4 to 73.6</td> </tr> <tr> <td>4 units</td> <td>○ *</td> <td>18.0 to 73.6</td> </tr> <tr> <td>5 units</td> <td>○ *</td> <td>18.0 to 100.5</td> </tr> </tbody> </table>	Operation mode	No. of operating unit	Combination of indoor units	Compressor revolution (rps)	HEAT	1 unit	M07	12 to 42.5	M10	12 to 42.5	M13	12 to 51.5	M16	12 to 54.4	M18	12 to 69.4	2 units	○ *	12 to 73.6	3 units	○ *	14.4 to 73.6	4 units	○ *	18.0 to 73.6	5 units	○ *	18.0 to 100.5
Operation mode	No. of operating unit	Combination of indoor units	Compressor revolution (rps)																																																																																			
COOL	1 unit	M07	12 to 22.1																																																																																			
		M10	12 to 22.1																																																																																			
		M13	12 to 34.1																																																																																			
		M16	12 to 43.1																																																																																			
		M18	12 to 44.9																																																																																			
	2 units	○ *	12 to 53.3																																																																																			
	3 units	○ *	24.5 to 56.2																																																																																			
	4 units	○ *	24.5 to 56.2																																																																																			
	5 units	○ *	24.5 to 80.2																																																																																			
	Operation mode	No. of operating unit	Combination of indoor units	Compressor revolution (rps)																																																																																		
HEAT	1 unit	M07	12 to 42.5																																																																																			
		M10	12 to 42.5																																																																																			
		M13	12 to 51.5																																																																																			
		M16	12 to 54.4																																																																																			
		M18	12 to 69.4																																																																																			
	2 units	○ *	12 to 73.6																																																																																			
	3 units	○ *	14.4 to 73.6																																																																																			
	4 units	○ *	18.0 to 73.6																																																																																			
	5 units	○ *	18.0 to 100.5																																																																																			
	Operation mode	No. of operating unit	Combination of indoor units	Compressor revolution (rps)																																																																																		
HEAT	1 unit	M07	12 to 42.5																																																																																			
		M10	12 to 42.5																																																																																			
		M13	12 to 51.5																																																																																			
		M16	12 to 54.4																																																																																			
		M18	12 to 69.4																																																																																			
	2 units	○ *	12 to 73.6																																																																																			
	3 units	○ *	14.4 to 73.6																																																																																			
	4 units	○ *	18.0 to 73.6																																																																																			
	5 units	○ *	18.0 to 100.5																																																																																			
	* : In case that any multiple indoor units are combined.																																																																																					
5. Current release control	<p>This function prevents troubles on the electronic parts of the compressor driving inverter.</p> <p>This function also controls drive circuit of the compressor speed so that electric power of the compressor drive circuit does not exceed the specified value.</p>  <table border="1" data-bbox="172 1727 1011 2047"> <thead> <tr> <th>Outdoor temp.</th> <th>Cooling current release value</th> <th>Heating current release value</th> </tr> </thead> <tbody> <tr> <td>40°C</td> <td rowspan="2">13.1 A</td> <td rowspan="2">12.6 A</td> </tr> <tr> <td>16°C</td> </tr> <tr> <td>11°C</td> <td rowspan="2">15.0 A</td> <td>12.6 A</td> </tr> <tr> <td>10.5°C</td> <td>18.0 A</td> </tr> </tbody> </table>	Outdoor temp.	Cooling current release value	Heating current release value	40°C	13.1 A	12.6 A	16°C	11°C	15.0 A	12.6 A	10.5°C	18.0 A	<ol style="list-style-type: none"> <li>The input current of the outdoor unit is detected in the inverter section of the outdoor unit.</li> <li>According to the detected outdoor temperature, the specified value of the current is selected.</li> <li>Whether the current value exceeds the specified value or not is judged.</li> <li>If the current value exceeds the specified value, this function reduces the compressor speed and controls speed up to the closest one commanded from the indoor unit within the range which does not exceed the specified value.</li> </ol>																																																																								
Outdoor temp.	Cooling current release value	Heating current release value																																																																																				
40°C	13.1 A	12.6 A																																																																																				
16°C																																																																																						
11°C	15.0 A	12.6 A																																																																																				
10.5°C		18.0 A																																																																																				



Item	Operation flow and applicable data, etc.	Description
<p>6. Release protective control by temperature of indoor heat exchanger</p>	<p><b>&lt;In cooling/dry operation&gt;</b>            (Prevent-freezing control for indoor heat exchanger)            In cooling/dry operation, the sensor of indoor heat exchanger detects evaporation temperature and controls the compressor speed so that temperature of the heat exchanger does not exceed the specified value.</p>	<ol style="list-style-type: none"> <li>1) When temperature of the indoor heat exchanger drops below 5°C, the compressor speed is reduced. (P zone)</li> <li>2) When temperature of the indoor heat exchanger rises in the range from 6°C to under 7°C, the compressor speed is kept. (Q zone)</li> <li>3) When temperature of the indoor heat exchanger rises to 7°C or higher, the capacity control operation returns to the usual control in cooling operation. (R zone)</li> </ol>
	<p><b>&lt;In heating operation&gt;</b>            (Prevent-overpressure control for refrigerating cycle)            In heating operation, the sensor of indoor heat exchanger detects condensation temperature and controls the compressor speed so that temperature of the heat exchanger does not exceed the specified value.</p>	<ol style="list-style-type: none"> <li>1) When temperature of the indoor heat exchanger rises in the range from 52°C to 55°C, the compressor speed is kept. (Q zone)            When temperature of the indoor heat exchanger drops in the range from 48°C to under 55°C, the compressor speed is kept. (Q zone)</li> <li>2) When temperature of the indoor heat exchanger rises to 55°C or higher, the compressor speed is reduced. (P zone)</li> <li>3) When temperature of the indoor heat exchanger does not rise to 52°C, or when it drops below to 48°C, the capacity control operation returns to the usual control in heating operation. (R zone)</li> </ol>

Item	Operation flow and applicable data, etc.	Description										
7. Winding/Coil heating control	<p>When the outdoor temperature is low, the windings/coils are heated to ensure compressor reliability.</p> 	<p>Winding/Coil heating is performed when the following conditions are met.</p> <p><b>Condition 1 :</b> When the discharge sensor temperature (Td) is less than 30°C.</p> <p><b>Condition 2 :</b> When the outdoor sensor temperature (To) is as shown in the left figure.</p>										
8. Defrost control (Only in heating operation)	<p>(This function removes frost adhered to the outdoor heat exchanger.)</p> <p>The temperature sensor of the outdoor heat exchanger (Te sensor) judges the frosting status of the outdoor heat exchanger and the defrost operation is performed with 4-way valve reverse defrost system.</p>  <p>* The minimum value of Te sensor 10 to 15 minutes after start of operation is stored in memory as Te0 and Te1. (-10°C &lt; Te1 ≤ 10°C)</p> <p style="text-align: center;"><b>Table 1</b></p> <table border="1" data-bbox="167 1377 933 1724"> <tr> <td><b>A zone</b></td> <td>When Te0 - TE ≥ 2.5 continued for 2 minutes in A zone, defrost operation starts.</td> </tr> <tr> <td><b>B zone</b></td> <td>When the operation continued for 2 minutes in B zone, defrost operation starts.</td> </tr> <tr> <td><b>C zone</b></td> <td>When Te0 - TE ≥ 3 continued for 2 minutes in C zone, defrost operation starts.</td> </tr> <tr> <td><b>D zone</b></td> <td>When the operation continued for 2 minutes in D zone, defrost operation starts.</td> </tr> <tr> <td><b>E zone</b></td> <td>When Te1 - TE ≥ 1 continued for 2 minutes in E zone, defrost operation starts.</td> </tr> </table>	<b>A zone</b>	When Te0 - TE ≥ 2.5 continued for 2 minutes in A zone, defrost operation starts.	<b>B zone</b>	When the operation continued for 2 minutes in B zone, defrost operation starts.	<b>C zone</b>	When Te0 - TE ≥ 3 continued for 2 minutes in C zone, defrost operation starts.	<b>D zone</b>	When the operation continued for 2 minutes in D zone, defrost operation starts.	<b>E zone</b>	When Te1 - TE ≥ 1 continued for 2 minutes in E zone, defrost operation starts.	<p>The necessity of defrost operation is detected by the outdoor heat exchanger temperature. The conditions to detect the necessity of defrost operation differ in A, B, C, D or E zone each. (Table 1)</p> <p><b>&lt;Defrost operation&gt;</b></p> <ul style="list-style-type: none"> <li>Defrost operation in A to E zones</li> </ul> <ol style="list-style-type: none"> <li>Stop operation of the compressor for 30 seconds.</li> <li>Invert (OFF) 4-way valve 10 seconds after stop of the compressor.</li> <li>The outdoor fan stops at the same time when the compressor stops.</li> <li>When temperature of the indoor heat exchanger becomes 38°C or lower, stop the indoor fan.</li> </ol> <p><b>&lt;Finish of defrost operation&gt;</b></p> <ul style="list-style-type: none"> <li>Returning conditions from defrost operation to heating operation</li> </ul> <ol style="list-style-type: none"> <li>Temperature of outdoor heat exchanger rises to +8°C or higher.</li> <li>Temperature of outdoor heat exchanger is kept at +5°C or higher for 80 seconds.</li> <li>Defrost operation continues for 10 minutes.</li> </ol> <p><b>&lt;Returning from defrost operation&gt;</b></p> <ol style="list-style-type: none"> <li>Stop operation of the compressor for approx. 60 seconds.</li> <li>Invert (ON) 4-way valve approx. 40 seconds after stop of the compressor.</li> <li>The outdoor fan starts rotating at the same time when the compressor starts.</li> </ol>
<b>A zone</b>	When Te0 - TE ≥ 2.5 continued for 2 minutes in A zone, defrost operation starts.											
<b>B zone</b>	When the operation continued for 2 minutes in B zone, defrost operation starts.											
<b>C zone</b>	When Te0 - TE ≥ 3 continued for 2 minutes in C zone, defrost operation starts.											
<b>D zone</b>	When the operation continued for 2 minutes in D zone, defrost operation starts.											
<b>E zone</b>	When Te1 - TE ≥ 1 continued for 2 minutes in E zone, defrost operation starts.											
9. Compressor protective control	<ol style="list-style-type: none"> <li>This control purposes to raise the operation frequency until 36Hz for 2 minutes in order to protect the compressor (Prevention of oil accumulation in the refrigerating cycle) when the status that the operation frequency is 36Hz or less has continued for 10 hours was calculated. The operation frequency follows the normal indoor command after controlling.</li> <li>Although the compressor may stop by THERMO-OFF control when the room temperature varies and then attains the set temperature by this control, it is not abnormal.</li> <li>During this control works, it stopping the operation by the remote controller, the operation does not continue.</li> </ol>											

Item	Operation flow and applicable data, etc.	Description																							
<p>10. Louver control</p> <p>1) Louver position</p> <p>2) Air direction adjustment</p> <p>3) Swing</p>	<p>This function controls the air direction of the indoor unit.</p> <ul style="list-style-type: none"> <li>The position is automatically controlled according to the operation mode (COOL/HEAT).</li> <li>The set louver position is stored in memory by the microcomputer, and the louver returns to the stored position when the next operation is performed. (Cooling/heating memory position)</li> </ul> <p>The angle of the louver is indicated as the horizontal angle is 0°. When the louver closes fully, it directs approx. 10° upward.</p> <p><b>1) Louver position in cooling operation</b></p> <table border="1" data-bbox="399 459 1417 638"> <thead> <tr> <th>Cooling operation/AUTO (COOL)</th> <th>Powerful</th> </tr> </thead> <tbody> <tr> <td></td> <td></td> </tr> <tr> <td>Initial setting of "Cooling storage position" Louver : Directs downward (23°) *1</td> <td>"Cooling storage position" Louver : Directs downward (34°)</td> </tr> </tbody> </table> <p>*1 When the indoor humidity is high (Hu sensor valve) <math>\geq 70\%</math>, the compressor speed is 23 rps or more and the position of the louver is less than 29°, the louver moves to 29° to prevent the air outlet from dew drop. And the louver can't move to less than 29°. When the indoor humidity becomes low or the compressor speed becomes less than 23 rps, the louver returns to the storage position.</p> <p><b>2) Louver position in heating operation</b></p> <table border="1" data-bbox="399 855 1417 1041"> <thead> <tr> <th>Heating operation/AUTO (HEAT)</th> <th>Powerful</th> </tr> </thead> <tbody> <tr> <td></td> <td></td> </tr> <tr> <td>Initial setting of "Heating storage position" Louver : Directs downward (72°)</td> <td>"Heating storage position" Louver : Directs downward (58°)</td> </tr> </tbody> </table> <p><b>SLEEP MODE operation</b></p> <table border="1" data-bbox="399 1066 1417 1384"> <thead> <tr> <th colspan="2">SLEEP MODE operation</th> </tr> </thead> <tbody> <tr> <td>In case that the following temperature is obtained during 12 minutes or 12 to 25 minutes from start of heating operation: Room temperature (TA) &lt; Set temperature (Tsc) -3.0</td> <td>In case that the following temperature is obtained during 12 to 25 minutes from start of heating operation: Room temperature (TA) <math>\geq</math> Set temperature (Tsc) -3.0 or when 25 minutes or more passed from start of heating operation.</td> </tr> <tr> <td></td> <td></td> </tr> <tr> <td>"Heating storage position" Louver : Directs downward (72°)</td> <td>"Cooling storage position" Louver : Directs downward (23°)</td> </tr> </tbody> </table> <p><b>3) Louver position in dry operation</b></p> <table border="1" data-bbox="906 1406 1417 1585"> <thead> <tr> <th>Dry operation</th> </tr> </thead> <tbody> <tr> <td></td> </tr> <tr> <td>Initial setting of "Cooling storage position" Louver : Directs downward (23°)*1</td> </tr> </tbody> </table> <p><b>Air direction adjustment sequence:</b></p>  <ul style="list-style-type: none"> <li>The louver position can be arbitrarily set up by pushing [FIX] button.</li> </ul> <p><b>Swing operation:</b></p> <ol style="list-style-type: none"> <li>When pushing [SWING] button during operation, the louver starts swinging.</li> <li>Each time you push the SWING button, you can change the swing mode. (Vertical swing → Horizontal swing → Vertical and Horizontal swing ® Stop swinging) <ul style="list-style-type: none"> <li>Swing operation is performed in width 35° with the stop position as the centre.</li> <li>If the stop position exceeds either upper or lower limit position, swing operation is performed in width 35° from the limit which the stop position exceeded.</li> </ul> </li> </ol>	Cooling operation/AUTO (COOL)	Powerful			Initial setting of "Cooling storage position" Louver : Directs downward (23°) *1	"Cooling storage position" Louver : Directs downward (34°)	Heating operation/AUTO (HEAT)	Powerful			Initial setting of "Heating storage position" Louver : Directs downward (72°)	"Heating storage position" Louver : Directs downward (58°)	SLEEP MODE operation		In case that the following temperature is obtained during 12 minutes or 12 to 25 minutes from start of heating operation: Room temperature (TA) < Set temperature (Tsc) -3.0	In case that the following temperature is obtained during 12 to 25 minutes from start of heating operation: Room temperature (TA) $\geq$ Set temperature (Tsc) -3.0 or when 25 minutes or more passed from start of heating operation.			"Heating storage position" Louver : Directs downward (72°)	"Cooling storage position" Louver : Directs downward (23°)	Dry operation		Initial setting of "Cooling storage position" Louver : Directs downward (23°)*1	
Cooling operation/AUTO (COOL)	Powerful																								
																									
Initial setting of "Cooling storage position" Louver : Directs downward (23°) *1	"Cooling storage position" Louver : Directs downward (34°)																								
Heating operation/AUTO (HEAT)	Powerful																								
																									
Initial setting of "Heating storage position" Louver : Directs downward (72°)	"Heating storage position" Louver : Directs downward (58°)																								
SLEEP MODE operation																									
In case that the following temperature is obtained during 12 minutes or 12 to 25 minutes from start of heating operation: Room temperature (TA) < Set temperature (Tsc) -3.0	In case that the following temperature is obtained during 12 to 25 minutes from start of heating operation: Room temperature (TA) $\geq$ Set temperature (Tsc) -3.0 or when 25 minutes or more passed from start of heating operation.																								
																									
"Heating storage position" Louver : Directs downward (72°)	"Cooling storage position" Louver : Directs downward (23°)																								
Dry operation																									
																									
Initial setting of "Cooling storage position" Louver : Directs downward (23°)*1																									

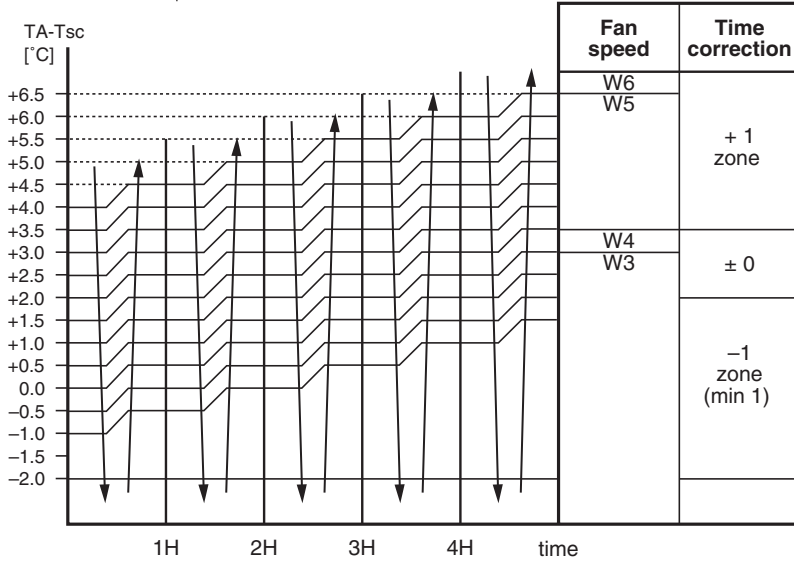
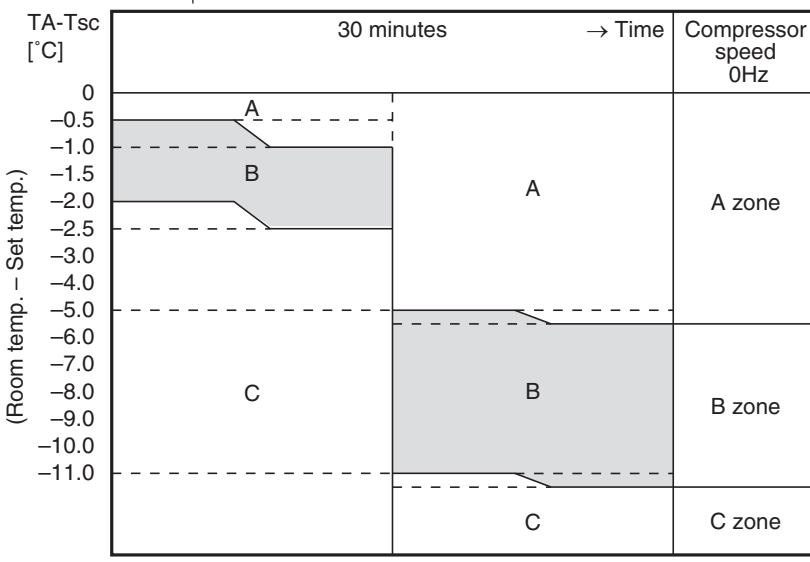
Item	Operation flow and applicable data, etc.	Description
<p>11. SLEEP MODE operation</p>	<p>When pushing [SLEEP MODE] button on the remote controller, a quiet and mild operation is performed by reducing the fan speed and the compressor speed.</p> <p><b>&lt;Cooling operation&gt;</b>  This function operates the air conditioner with the difference between the set and the room temperature as shown in the following figure.  The time correction is performed for 8 minutes each.</p>  <p><b>&lt;Heating operation&gt;</b></p> 	<p><b>&lt;Cooling operation&gt;</b></p> <ol style="list-style-type: none"> <li>1) The indoor fan speed is controlled between W6 and W3.  The compressor speed in control as shown in the left figure.</li> <li>2) The set temperature increased 0.5°C per hour up to 2°C starting from the set temperature when SLEEP MODE has been received.</li> </ol> <p><b>&lt;Heating operation&gt;</b></p> <ol style="list-style-type: none"> <li>1) The indoor fan speed is controlled within (W7) as maximum value.</li> <li>2) The louver position is set horizontally (Standard cooling position) when the room temperature comes close to the set temperature or when 25 minutes passed after starting SLEEP MODE operation.</li> </ol>

Item	Operation flow and applicable data, etc.	Description
12. Temporary operation	<p>Pushing [RESET] button starts the temporary operation of [AUTO] operation. When keeping [RESET] button pushed for 10 seconds or more, the temporary [COOL] operation is performed.</p>	<ol style="list-style-type: none"> <li>When pushing [RESET] button, the temporary [AUTO] operation starts.</li> <li>When keeping [RESET] button pushed for 3 seconds or more, “beep, beep, beep” sound is heard and [AUTO RESTART] control is changed.</li> <li>When keeping [RESET] button pushed for 10 seconds or more, “beep” sound is heard and the temporary [COOL] operation starts.</li> <li>If the filter lamp goes on, push [RESET] button to go off the filter lamp, and then push [RESET] button again.</li> <li>To stop the temporary operation, push the button again.</li> </ol>

Present status	Operation button	
	PURE button	Air conditioner
Stop	Air purifier	AC operation*
Air purifier only	Stop (All)	AC + Air purifier
Air conditioner	AC + Air purifier	All stop
Joint use of AC and air purifier	AC operation	All stop

  

	Louver swing is available	Fan speed *1
Air purifying operation	Cooling position	AUTO, L, L+, M, M+, H
AC + Air purifying operation	Follows to AC operation	Follows to AC operation

### 1. Purpose

This function generates negative ion while cleaning the air in the room. The air purifying control function is to alert the user that something is wrong in the ionizing or air purifying operation. If air purifier-ON signal is received while the air conditioner stops, the air purifier starts operation, and if it is received while the air conditioner operates, the air conditioner and the air purifier start operation. The air ion generator operates linked with the air purifying operation.

**NOTE** When the previous operation was the operation of air conditioner + air purifier, an operation of air conditioner + air purifier starts by pushing AC button on the remote controller. (Operation of air conditioner + air purifier is stored in memory.)

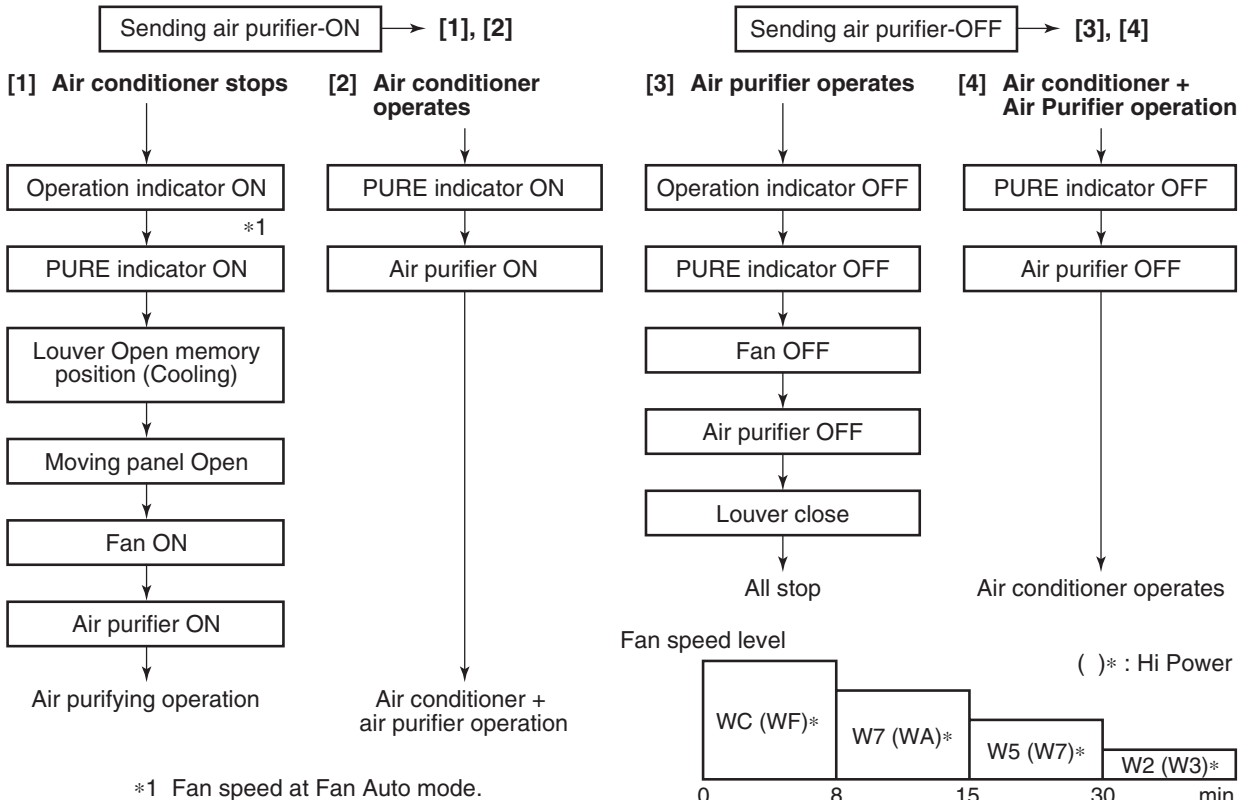

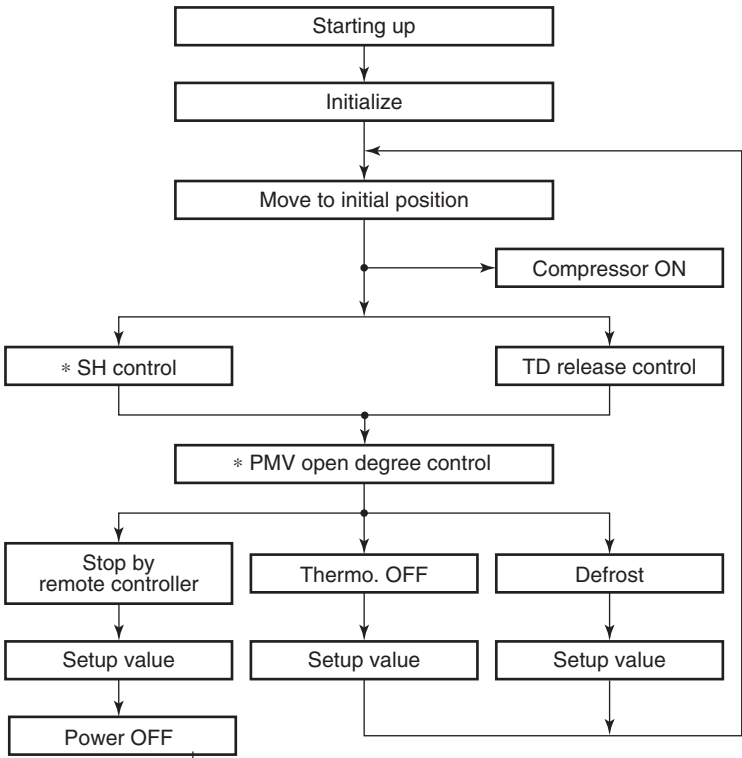

Item	Operation flow and applicable data, etc.	Description
<p>13. Air purifying control (Continued)</p> <p>Air purifying operation</p> <pre> graph TD     A[Operation indicator ON] --&gt; B[PURE indicator Blue ON]     B --&gt; C[Air purifier ON]     C --&gt; D{Error input is detected}     D -- NO --&gt; C     D -- YES --&gt; E[Air purifier OFF]     E --&gt; F{Error input was detected 5 times or more}     F -- NO --&gt; D     F -- YES --&gt; G[Air purifier power estimates 1000H]     G --&gt; H{Approx. 10 minutes passed from the error input was detected.}     H -- NO --&gt; F     H -- YES --&gt; I[PURE indicator Orange ON]     I --&gt; J[ ]     J --&gt; K[ ]     style J fill:none,stroke:none     style K fill:none,stroke:none     </pre> <p>[1] Reset by RESET button. [2] Reset by RESET button or by the stop direction from the remote controller.</p> <p><b>NOTE</b> When the breaker is turned [ON] or RESET button is pushed while the FILTER indicator is turned on, the air purifier is not turned on until the integrated operation time of the indoor fan exceeds 1 hour after operation start. It is the safety measures considering an incomplete drain when electric dust collector has been cleaned with water.</p>	<p><b>2. Description</b></p> <p>Error is determined to have occurred (indicated by the PURE indicator (Orange) in the following two cases.</p> <ol style="list-style-type: none"> <li>1) When the panel switch has been set to OFF by the opening of the air inlet grill, etc.</li> <li>2) When an abnormal discharge caused by a symptom such as the build-up of dirt has been detected while the air purifier is ON.</li> </ol> <p><b>NOTE</b> The above case 1) or 2) is deemed to have occurred when the action concerned continues for more than one second.</p> <p><b>3. Operation</b></p> <p>The sequence that PURE indicator (Orange) is turned on are described in the following flowchart.</p> <ol style="list-style-type: none"> <li>1) If the air purifying error input was detected by 5 times or under, turn on the purifier again approx. 10 minutes after and judge it again.</li> <li>2) If the air purifying error input was detected by 5 times or more and 1000 H timer counts up, determine the error and turn on the PURE indicator (Orange).</li> <li>3) The FILTER indicator keeps lighting even if the operation is stopped by the remote controller.</li> </ol> <p>The timer is stored in memory of the microcomputer, and the operation time is cleared by filter RESET button on the indoor unit. (FILTER indicator goes off.)</p>	

Item	Operation flow and applicable data, etc.	Description														
<p>14. Discharge temperature control</p> <table border="1" data-bbox="167 347 912 683"> <thead> <tr> <th>Td value</th> <th>Control operation</th> </tr> </thead> <tbody> <tr> <td>117°C</td> <td>Judges as an error and stops the compressor.</td> </tr> <tr> <td>112°C</td> <td>Reduce the compressor speed.</td> </tr> <tr> <td>108°C</td> <td>Reduce slowly compressor speed.</td> </tr> <tr> <td>105°C</td> <td>Keeps the compressor speed.</td> </tr> <tr> <td>98°C</td> <td>If the operation is performed with lower speed than one commanded by the serial signal, speed is slowly raised up to the commanded speed.</td> </tr> <tr> <td></td> <td>Operates with speed commanded by the serial signal.</td> </tr> </tbody> </table>	Td value	Control operation	117°C	Judges as an error and stops the compressor.	112°C	Reduce the compressor speed.	108°C	Reduce slowly compressor speed.	105°C	Keeps the compressor speed.	98°C	If the operation is performed with lower speed than one commanded by the serial signal, speed is slowly raised up to the commanded speed.		Operates with speed commanded by the serial signal.		<p><b>1. Purpose</b> This function detects error on the refrigerating cycle or error on the compressor, and performs protective control.</p> <p><b>2. Operation</b></p> <ul style="list-style-type: none"> <li>Control of the compressor speed The speed control is performed as described in the left table based upon the discharge temperature.</li> </ul>
Td value	Control operation															
117°C	Judges as an error and stops the compressor.															
112°C	Reduce the compressor speed.															
108°C	Reduce slowly compressor speed.															
105°C	Keeps the compressor speed.															
98°C	If the operation is performed with lower speed than one commanded by the serial signal, speed is slowly raised up to the commanded speed.															
	Operates with speed commanded by the serial signal.															
<p>15. Pulse motor valve (PMV) control</p>  <pre> graph TD     Start[Starting up] --&gt; Init[Initialize]     Init --&gt; Move[Move to initial position]     Move --&gt; Comp[Compressor ON]     Move --&gt; SH[* SH control]     Move --&gt; TD[TD release control]     SH --&gt; PMV[* PMV open degree control]     TD --&gt; PMV     PMV --&gt; Remote[Stop by remote controller]     PMV --&gt; Thermo[Thermo. OFF]     PMV --&gt; Defrost[Defrost]     Remote --&gt; Setup1[Setup value]     Thermo --&gt; Setup2[Setup value]     Defrost --&gt; Setup3[Setup value]     Setup1 --&gt; Power[Power OFF]     Setup2 --&gt; Power     Setup3 --&gt; Power   </pre> <p>* SH (Super Heat amount) = Ts (Temperature of suction pipe of the compressor) – Tc or Te (Heat exchanger temperature at evaporation side)</p> <p>* PMV: Pulse Motor Valve</p>		<ol style="list-style-type: none"> <li>When starting the operation, move the valve once until it fits to the stopper. (Initialize) * In this time, "Click" sound may be heard.</li> <li>Adjust the open degree of valve by super heat amount. (SH control)</li> <li>If the discharge temperature was excessively up, adjust the open degree of valve so that it is in the range of set temperature. (Discharge temp. control)</li> <li>When defrost operation is performed, the open degree of PMV is adjusted according to each setup conditions during preparation for defrost and during defrost operation (4-way valve is inversed.).</li> <li>When turning off the compressor by thermo. OFF or STOP by remote controller, the open degree of the PMV is adjusted to the setup value.</li> </ol>														

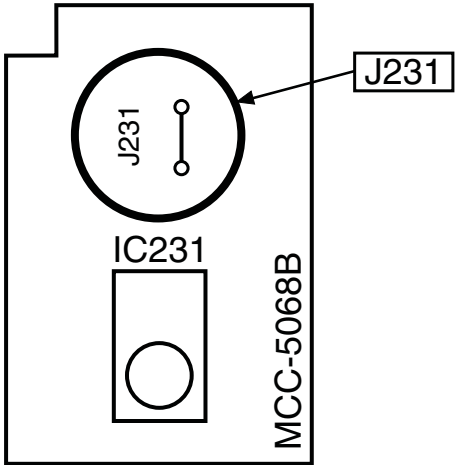

Item	Operation flow and applicable data, etc.	Description													
16. Clean operation	<div style="text-align: center;"> <pre> graph TD     A[Unit now performing cooling or dry operation] --&gt; B[Push "STOP" button]     B --&gt; C[Only S.CLEAN indicator lights, and clean operation starts]     C --&gt; D[Time set now elapses]     D --&gt; E[Operation stops]           </pre> </div> <ul style="list-style-type: none"> <li>• During clean operations: The louver opens slightly. The indoor fan operates continuously at a speed of 450 rpm. Clean operation times</li> </ul> <p><b>Clean operation times</b></p> <table border="1" data-bbox="406 1164 1420 1467"> <thead> <tr> <th>Operation mode</th> <th>Operation time</th> <th>Clean operation time</th> </tr> </thead> <tbody> <tr> <td rowspan="2">Cooling: Auto (cooling) Dry</td> <td>Up to 10 minutes</td> <td>No clean operation performed (0 minutes)</td> </tr> <tr> <td>10 minutes or longer</td> <td>4 hours</td> </tr> <tr> <td>Heating: Auto (heating)</td> <td rowspan="3">No clean operation performed</td> <td></td> </tr> <tr> <td>Auto (fan only)</td> </tr> <tr> <td>Shutdown</td> </tr> </tbody> </table> <ul style="list-style-type: none"> <li>• To stop an ongoing clean operation at any time Push the start/stop button on the remote controller twice during the clean operation. (After pushing the button for the first time, push it for the second time without delay (within 10 minutes).)</li> </ul>	Operation mode	Operation time	Clean operation time	Cooling: Auto (cooling) Dry	Up to 10 minutes	No clean operation performed (0 minutes)	10 minutes or longer	4 hours	Heating: Auto (heating)	No clean operation performed		Auto (fan only)	Shutdown	<p><b>1. Purpose</b></p> <p>The clean operation is to minimize the growth of mold, bacteria etc. by running the fan and drying so as to keep the inside of the air conditioner clean.</p> <p><b>Clean operation</b></p> <p>When the cooling or dry operation shuts down, the unit automatically starts the clean operation which is then performed for the specified period based on duration of the operation which was performed prior to the shutdown, after which the clean operation stops. (The clean operation is not performed after a heating operation.)</p> <p><b>2. Operation</b></p> <ol style="list-style-type: none"> <li>1) When the stop signal from the remote controller is received, the S.CLEAN indicator (Orange) on the main body lights, and the clean operation starts. (Neither the OPERATION indicator nor the PURE indicator light.)</li> <li>2) The period of the clean operation is determined by the duration of the operation performed prior to the reception of the stop code.</li> <li>3) After the clean operation has been performed for the specified period, the unit stops operating.</li> </ol>
Operation mode	Operation time	Clean operation time													
Cooling: Auto (cooling) Dry	Up to 10 minutes	No clean operation performed (0 minutes)													
	10 minutes or longer	4 hours													
Heating: Auto (heating)	No clean operation performed														
Auto (fan only)															
Shutdown															

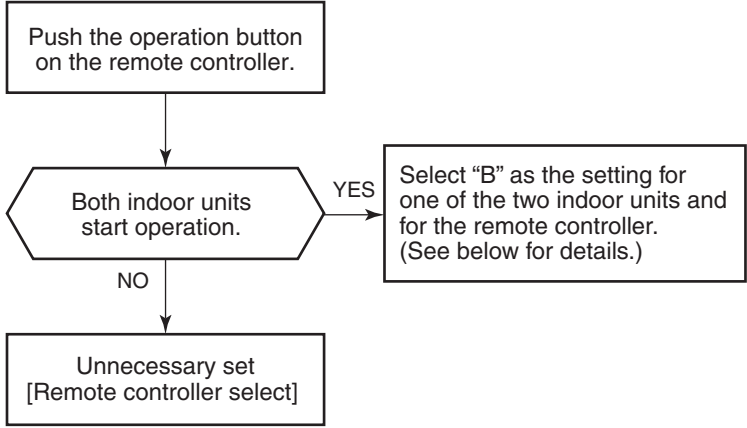
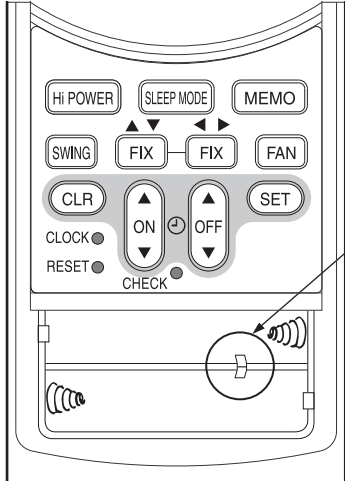
Item	Operation flow and applicable data, etc.	Description
17. Clean operation	<p><b>Setting the clean operation cancel</b></p> <div style="border: 1px solid black; padding: 5px; margin-bottom: 5px;">Add J231 of the wireless unit P.C. board assembly. * This cancels the auto restart function.</div> <p style="text-align: center;">↓</p> <div style="border: 1px solid black; padding: 5px; margin-bottom: 5px;">Hold down the [RESET] button on the indoor unit for at least 3 seconds but not more than 10 seconds.</div> <p style="text-align: center;">↓</p> <div style="border: 1px solid black; padding: 5px; margin-bottom: 5px;">The indoor unit's buzzer emits three beeps.</div> <p style="text-align: center;">↓</p> <div style="border: 1px solid black; padding: 5px; margin-bottom: 5px;">This completes the clean operation cancel setting.</div> <p><b>Setting the clean operation</b></p> <div style="border: 1px solid black; padding: 5px; margin-bottom: 5px;">Hold down the [RESET] button on the indoor unit for at least 3 seconds but not more than 10 seconds.</div> <p style="text-align: center;">↓</p> <div style="border: 1px solid black; padding: 5px; margin-bottom: 5px;">The indoor unit's buzzer emits three beeps, and the OPERATION indicator flashes at 5 Hz intervals.</div> <p style="text-align: center;">↓</p> <div style="border: 1px solid black; padding: 5px; margin-bottom: 5px;">This completes the clean operation setting.</div> <p><b>Indoor P.C. board</b></p> 	<p style="text-align: center;"><b>⚠ CAUTION</b></p> <p>* J231 will be near the MCU so take steps to ensure that it will not be exposed to excessive levels of heat. Also take care to avoid solder bridging with the surrounding components.</p> <p><b>NOTE</b> Once J231 is added, the [RESET] button on the unit is designated for CLEAN OPERATION (Set/Cancel), therefore the [RESET] button can not be used for the selection (Set/ Cancel) of AUTO RESTART function (Refer to <b>9-3. Auto Restart Function</b>).</p>

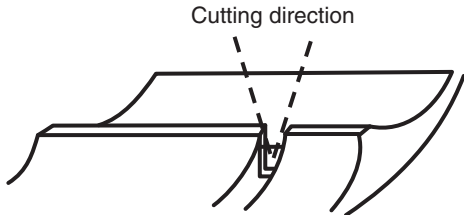
Item	Operation flow and applicable data, etc.	Description
<p>18. Select switch on remote controller</p>		<p><b>1. Purpose</b> This operation is to operate only one indoor unit using one remote controller.</p> <p><b>2. Description</b> When operating one indoor unit in a situation where two indoor units have been installed in the same room or nearby rooms, this operation prevents the remote controller signal from being received simultaneously by both units, thus preventing both units from operating.</p> <p><b>3. Operation</b> The indoor unit on which the remote controller selection has been set to B receives the signal of the remote controller also set to B. (At the factory the remote controller selection is set to A on all the indoor units. There is no A setting display.)</p>
	<p><b>Setting the remote controller</b> Switching between A and B is enabled by cutting the jumper wire inside the battery box using pliers.</p> <ol style="list-style-type: none"> <li>Slide open the remote controller cover and remove the batteries.</li> <li>Cut the jumper wire inside the battery compartment using nippers. <ul style="list-style-type: none"> <li>The jumper wire should not remain in contact after being cut. Also, be careful not to let plastic scraps, jumper wire cuttings or other debris enter the inside of the remote controller.</li> </ul> </li> <li>Insert the batteries. "B" appears in the remote controller display. <ul style="list-style-type: none"> <li>* Even after the jumper wire has been cut, switching between A and B is still possible by pushing the CHECK button and FIX button together. The A or B setting, which was switched by pushing the CHECK button and FIX (▲ / ▼) button together, is restored to the setting established prior to the switching when the battery is replaced or the RESET button is pushed.</li> <li>* When switching between settings "A" and "B", always switch the indoor unit board and the remote controller as a pair. (Otherwise, the indoor unit will not accept the remote controller's signals.)</li> </ul> </li> <li>Push the RESET button (Indoor unit) to start automatic operation.</li> <li>Push the  button of the remote controller that was set in step 1 to stop the air conditioner. (This operation will change the setting to "B".)</li> <li>Check that the remote controller operates the indoor unit.</li> </ol>	

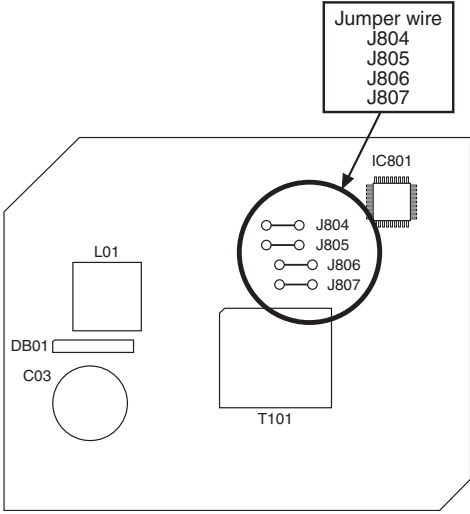
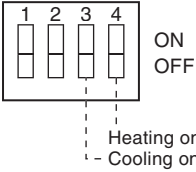
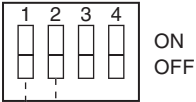
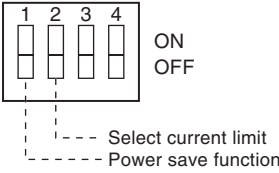
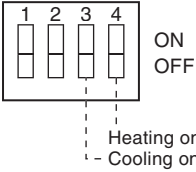
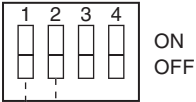
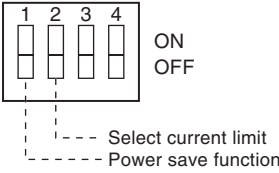
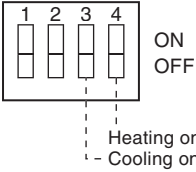
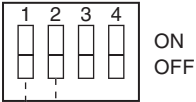
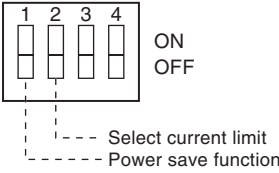
Item	Operation flow and applicable data, etc.	Description																																
<p>19. Set temperature correction</p>	<p><b>Indoor Control P.C. Board (Factory Default)</b></p>  <p><b>In HEAT Operation</b></p> <table border="1" data-bbox="427 922 898 1151"> <thead> <tr> <th colspan="2">Jumper wire setup</th> <th rowspan="2">HEAT shift value</th> </tr> <tr> <th>J804</th> <th>J805</th> </tr> </thead> <tbody> <tr> <td>X</td> <td>X</td> <td>-2</td> </tr> <tr> <td>X</td> <td>O</td> <td>+4</td> </tr> <tr> <td>O</td> <td>X</td> <td>+2</td> </tr> <tr> <td>O</td> <td>O</td> <td>0</td> </tr> </tbody> </table> <p>O : With Jumper wire X : Cut Jumper wire</p>	Jumper wire setup		HEAT shift value	J804	J805	X	X	-2	X	O	+4	O	X	+2	O	O	0	<p><b>1. Purpose</b></p> <p>When the difference between the set temp. of the remote controller and the room temp. is wide due to the installation condition, etc, the set temp. is corrected. (HEAT operation only)</p> <p><b>2. Description</b></p> <p>The set temp. received from the remote controller is corrected.</p> <p>The correct value from <math>-2^{\circ}\text{C}</math> to <math>+4^{\circ}\text{C}</math> is changed by the jumper wire on P.C. board of the indoor microcomputer.</p> <p>← At shipment</p>															
Jumper wire setup		HEAT shift value																																
J804	J805																																	
X	X	-2																																
X	O	+4																																
O	X	+2																																
O	O	0																																
<p>20. Various setting on outdoor unit (Power save, Cooling-only, etc.)</p>	<p><b>The following settings are available by DIP switch setup.</b></p> <table border="1" data-bbox="427 1335 1430 1886"> <thead> <tr> <th>Function</th> <th>Setting position</th> <th>Control contents</th> </tr> </thead> <tbody> <tr> <td>Power save setup</td> <td> <p>SW801</p>  </td> <td> <p>Turn the switch to ON, when using the power save function.</p> <p>SW802</p> <table border="1" data-bbox="898 1469 1401 1603"> <thead> <tr> <th>No.</th> <th>1</th> <th>2</th> <th>3</th> <th>4</th> </tr> </thead> <tbody> <tr> <td>No.1</td> <td>ON</td> <td>ON</td> <td>OFF</td> <td>OFF</td> </tr> <tr> <td>No.2</td> <td>OFF</td> <td>ON</td> <td>ON</td> <td>OFF</td> </tr> <tr> <td>Current limit</td> <td>11A</td> <td>8.5A</td> <td>Full</td> <td>Full (Default)</td> </tr> </tbody> </table> </td> </tr> <tr> <td>Cooling-only setup</td> <td> <p>SW802</p>  </td> <td> <p>When using the air conditioner as a cooling-only conditioner, turn the switch to ON. (If the heating mode is selected by remote control, outdoor unit will remain stop. If mixed with indoor unit cooling and heating, outdoor unit performs cooling operation.)</p> </td> </tr> <tr> <td>Heating-only setup</td> <td>  </td> <td> <p>When using the air conditioner as a heating-only conditioner, turn the switch to ON. (If the cooling mode is selected by remote control, outdoor unit will remain stop. If mixed with indoor unit cooling and heating, outdoor unit performs heating operation.)</p> </td> </tr> </tbody> </table> <p>Caution: Set the switch before turning on the power supply.</p>	Function	Setting position	Control contents	Power save setup	<p>SW801</p> 	<p>Turn the switch to ON, when using the power save function.</p> <p>SW802</p> <table border="1" data-bbox="898 1469 1401 1603"> <thead> <tr> <th>No.</th> <th>1</th> <th>2</th> <th>3</th> <th>4</th> </tr> </thead> <tbody> <tr> <td>No.1</td> <td>ON</td> <td>ON</td> <td>OFF</td> <td>OFF</td> </tr> <tr> <td>No.2</td> <td>OFF</td> <td>ON</td> <td>ON</td> <td>OFF</td> </tr> <tr> <td>Current limit</td> <td>11A</td> <td>8.5A</td> <td>Full</td> <td>Full (Default)</td> </tr> </tbody> </table>	No.	1	2	3	4	No.1	ON	ON	OFF	OFF	No.2	OFF	ON	ON	OFF	Current limit	11A	8.5A	Full	Full (Default)	Cooling-only setup	<p>SW802</p> 	<p>When using the air conditioner as a cooling-only conditioner, turn the switch to ON. (If the heating mode is selected by remote control, outdoor unit will remain stop. If mixed with indoor unit cooling and heating, outdoor unit performs cooling operation.)</p>	Heating-only setup		<p>When using the air conditioner as a heating-only conditioner, turn the switch to ON. (If the cooling mode is selected by remote control, outdoor unit will remain stop. If mixed with indoor unit cooling and heating, outdoor unit performs heating operation.)</p>	
Function	Setting position	Control contents																																
Power save setup	<p>SW801</p> 	<p>Turn the switch to ON, when using the power save function.</p> <p>SW802</p> <table border="1" data-bbox="898 1469 1401 1603"> <thead> <tr> <th>No.</th> <th>1</th> <th>2</th> <th>3</th> <th>4</th> </tr> </thead> <tbody> <tr> <td>No.1</td> <td>ON</td> <td>ON</td> <td>OFF</td> <td>OFF</td> </tr> <tr> <td>No.2</td> <td>OFF</td> <td>ON</td> <td>ON</td> <td>OFF</td> </tr> <tr> <td>Current limit</td> <td>11A</td> <td>8.5A</td> <td>Full</td> <td>Full (Default)</td> </tr> </tbody> </table>	No.	1	2	3	4	No.1	ON	ON	OFF	OFF	No.2	OFF	ON	ON	OFF	Current limit	11A	8.5A	Full	Full (Default)												
No.	1	2	3	4																														
No.1	ON	ON	OFF	OFF																														
No.2	OFF	ON	ON	OFF																														
Current limit	11A	8.5A	Full	Full (Default)																														
Cooling-only setup	<p>SW802</p> 	<p>When using the air conditioner as a cooling-only conditioner, turn the switch to ON. (If the heating mode is selected by remote control, outdoor unit will remain stop. If mixed with indoor unit cooling and heating, outdoor unit performs cooling operation.)</p>																																
Heating-only setup		<p>When using the air conditioner as a heating-only conditioner, turn the switch to ON. (If the cooling mode is selected by remote control, outdoor unit will remain stop. If mixed with indoor unit cooling and heating, outdoor unit performs heating operation.)</p>																																

### 9-3. Auto Restart Function

This indoor unit is equipped with an automatic restarting function which allows the unit to restart operating with the set operating conditions in the event of a power supply being accidentally shut down.

The operation will resume without warning 3 minutes after power is restored.

This function is not set to work when shipped from the factory. Therefore it is necessary to set it to work.

#### 9-3-1. Setting the Auto Restart Function

To set the auto restart function, proceed as follows:

The power supply to the unit must be on ; the function will not set if the power is off.

Push the [RESET] button located in the center of the front panel continuously for 3 seconds.

The unit receives the signal and beeps 3 times.

The unit then restarts operating automatically in the event of power supply being accidentally shut down.

#### • When the unit is standby (Not operating)

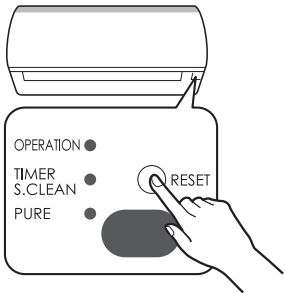
Operation	Motions
<p>Push [RESET] button for more than 3 seconds. (Less than 10 seconds)</p> 	<p>The unit is on standby. ↓ (Push [RESET] button for more than 3 seconds.) The unit starts to operate. The green indicator is on. ↓ After approx. 3 seconds, The unit beeps 3 times and continues to operate. <b>The green indicator flashes for 5 seconds.</b> If the unit is not required to operate at this time, push [RESET] button once more or use the remote controller to turn it off.</p>

#### • When the unit is in operation

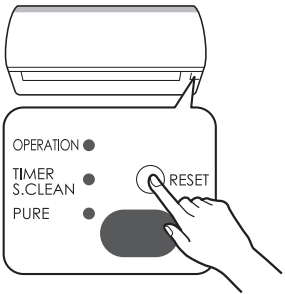
Operation	Motions
<p>Push [RESET] button for more than 3 seconds. (Less than 10 seconds)</p> 	<p>The unit is in operation. The green indicator is on. ↓ (Push [RESET] button for more than 3 seconds.) The unit stops operating. The green indicator is turned off. ↓ After approx. 3 seconds, The unit beeps 3 times. <b>The green indicator flashes for 5 seconds.</b> If the unit is required to operate at this time, push [RESET] button once more or use the remote controller to turn it on.</p>

### NOTE

- After restarting the air conditioner by the AUTO RESTART OPERATION, the louver swing (AUTO) operation doesn't resume.
- While the PURE indicator (Orange) is on, the RESET button has the function of air purifier reset button.

### 9-3-2. Cancel the Auto Restart Function

To cancel auto restart function, proceed as follows :

Repeat the setting procedure : the unit receives the signal and beeps 3 times.

The unit will be required to be turned on with the remote controller after the main power supply is turned off.

#### • When the system is on stand-by (not operating)

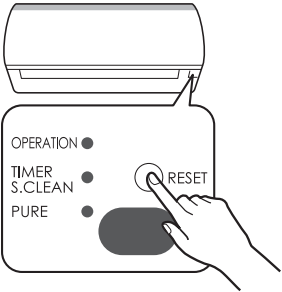
Operation	Motions
<p>Push [RESET] button for more than 3 seconds. (Less than 10 seconds)</p> 	<p>The unit is on standby.            ↓ (Push [RESET] button for more than 3 seconds.)            The unit starts to operate. The green indicator is on.            ↓ After approx. 3 seconds,            The unit beeps 3 times and continues to operate.            If the unit is not required to operate at this time, push [RESET] button once more or use the remote controller to turn it off.</p>

#### • When the system is operating

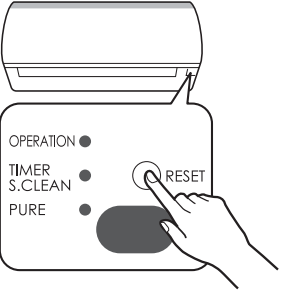
Operation	Motions
<p>Push [RESET] button for more than 3 seconds. (Less than 10 seconds)</p> 	<p>The unit is in operation. The green indicator is on.            ↓ (Push [RESET] button for more than 3 seconds.)            The unit stops operating. The green indicator is turned off.            ↓ After approx. 3 seconds,            The unit beeps 3 times.            If the unit is required to operate at this time, push [RESET] button once more or use the remote controller to turn it on.</p>

### 9-3-3. Power Failure During Timer Operation

When the unit is turned off because of power failure during timer operation, the timer operation is cancelled.

In that case, set the timer operation again.

#### NOTE

The Everyday Timer is reset while a command signal can be received from the remote controller even if it stopped due to a power failure.

## 9-4. Remote Controller and Its Functions

### 9-4-1. Parts Name of Remote Controller

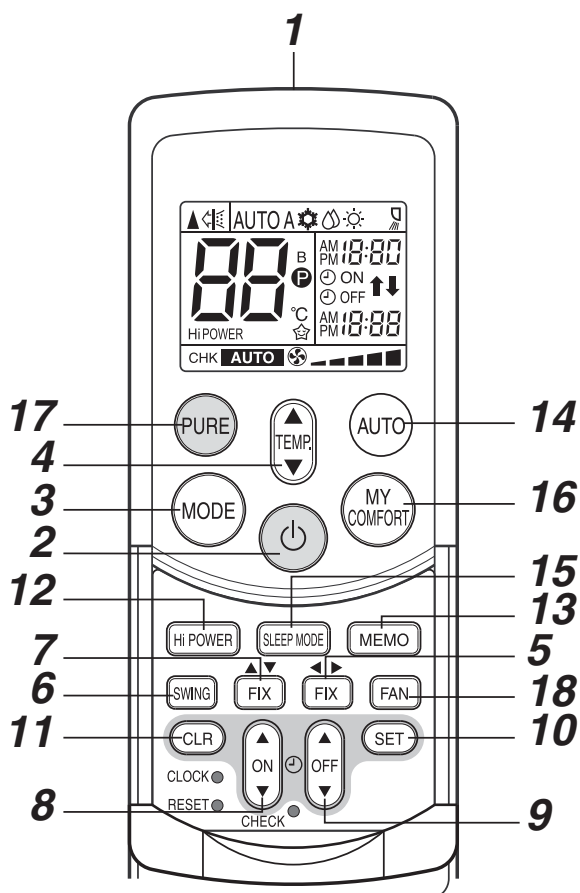

#### 1 Infrared signal transmitter

Transmits signals to the indoor unit.

#### 2 button

Push the button to start operation.

(A receiving beep is heard.)

Push the button again to stop operation.

(A receiving beep is heard.)

If the receiving beep isn't heard from the indoor unit, push the button again.

#### 3 Mode select button (MODE)

Push this button to select a mode.

Each time you push the button, the modes cycle in

order from A: Auto change over control,

 : COOL,  : DRY,  : HEAT and back to A.

(A receiving beep is heard.)

#### 4 Temperature button ( )

▲ ... The temperature setting is raised to 30°C.

▼ ... The temperature setting is lowered to 17°C.

(A receiving beep is heard.)...

#### 5 Set horizontal air flow button (FIX)

Push this button to adjust the horizontal air flow direction. (A receiving beep is heard.)

#### 6 Set vertical air flow button (FIX)

Push this button to adjust the vertical air flow direction. (A receiving beep is heard.)

#### 7 Auto louver button (SWING)

Each time you push the SWING button, you can change the swing mode. (A receiving beep is heard.) (Vertical swing → Horizontal swing → Vertical and Horizontal swing → Stop swinging)

Push the button again to stop the swinging mode. (A receiving beep is heard.)

#### 8 ON timer button (ON)

Use this button to change the clock and ON timer times.

To move up the time, push ▲ of the ON  button.

To move down the time, push ▼ of the ON  button.

#### 9 OFF timer button (OFF)

Use this button to change the OFF timer times.

To move up the time, push ▲ of the OFF  button.

To move down the time, push ▼ of the OFF  button.

#### 10 Reserve button (SET)

Push this button to store the time settings.

(A receiving beep is heard.)

#### 11 Cancel button (CLR)

Push this button to cancel the ON timer and OFF timer. (A receiving beep is heard.)

#### 12 High power button (Hi POWER)

Push this button to start high power operation.

#### 13 Memory button (MEMO)

Push this button to ready for storing the settings.

Hold down the button for 3 seconds or more to store the  mark is displayed.

#### 14 Automatic operation button (AUTO)

Push this button to operate the air conditioner automatically. (A receiving beep is heard.)

#### 15 SLEEP MODE button

Push this button to start sleep mode.

#### 16 MY COMFORT button

Push this button to operate the air conditioner according to the settings stored using the MEMO button.

#### 17 PURE button (PURE)

Push this button to start the electrical air purifying operation.





Push the button again to stop operation.

#### 18 Fan speed button (FAN)

Push this button to select the fan speed.

When you select AUTO, the fan speed is automatically adjusted according to the room temperature.

You can also manually select the desired fan speed from five available settings.

(LOW , LOW+ , MED , MED+ , HIGH ) (A receiving beep is heard.)



## 9-4-2. Name and Functions of Indications on Remote Controller



### [Display]

All indications, except for the clock time indicator, are displayed by pushing the  button.

#### 1 Transmission mark

This transmission mark  indicates when the remote controller transmits signals to the indoor unit.

#### 2 Mode indicator

Indicates the current operation mode.  
(AUTO : Automatic control, A : Auto changeover control,  : Cool,  : Dry,  : Heat)

#### 3 Temperature indicator





Indicates the temperature setting. (17°C to 30°C)

#### 4 PURE indicator

Shows that the electrical air purifying operation is in progress.

#### 5 FAN speed indicator

Indicates the selected fan speed.

AUTO or five fan speed levels (LOW , LOW+ , MED , MED+ , HIGH ) can be shown.

Indicates AUTO when the operating mode is either AUTO or  : Dry.

#### 6 TIMER and clock time indicator

The time setting for timer operation or the clock time is indicated.

The current time is always indicated except during TIMER operation.

#### 7 Hi POWER indicator

Indicates when the Hi POWER operation starts.

Push the Hi POWER button to start and push it again to stop the operation.

#### 8 (MEMORY) indicator

Flashes for 3 seconds when the MEMO button is pushed during operation.

The  mark is shown when holding down the button for 3 seconds or more while the mark is flashing. Push another button to turn off the mark.

#### 9 SLEEP mode indicator

Indicates when the SLEEP MODE is in activated.

Push the SLEEP MODE button to start and push it again to stop operation.

#### 10 A, B change indicator remote controller

When the remote controller switching function is set, "B" appears in the remote controller display. (When the remote controller setting is "A", there is no indication at this position.)

### NOTE

Remote controller switching function

- If two indoor units are installed in the same room or adjoining rooms, both units may start and stop at the same time when the remote controller is operated.

This can be prevented by setting the switching function so that each indoor unit is operated only by the corresponding remote controller.

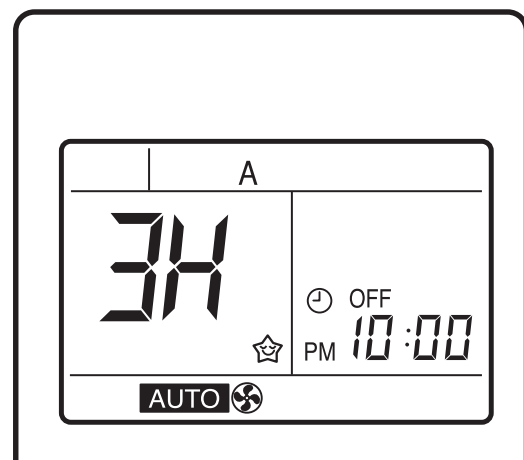
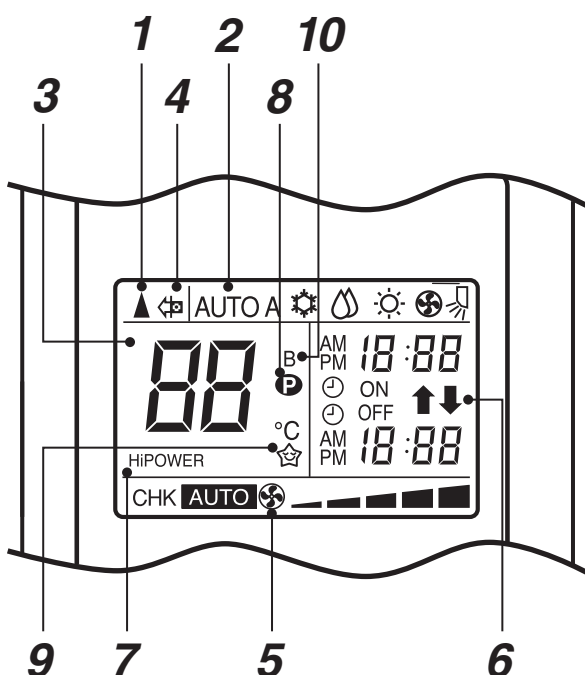

### 9-5. Hi POWER Mode

When [Hi POWER] button is pushed while the indoor unit is in Auto, Cooling or Heating operation, Hi POWER mark is indicated on the display of the remote controller and the unit operates according to the present operation mode as described below.

#### 1. Automatic operation

The preset temperature changes according to the operation mode selected.

In the Cooling operation, the preset temperature drops by 1°C.

In the Heating operation, the preset temperature increases by 2°C.

#### 2. Cooling operation (Manual)

The preset temperature drops 1°C.

(The value of the preset temperature on the remote controller does not change.)

#### 3. Heating operation (Manual)

The preset temperature increases 2°C.

(The value of the preset temperature on the remote controller does not change.)

#### 4. The Hi POWER mode can not be set in Dry operation

#### 5. Release of Hi POWER mode

Push [Hi POWER] button on the remote controller again.

### 9-6. Intermittent Operation Control for Indoor Fans of the Indoor Unit at Thermo-off Side in Heating Operation

While heating operation is executed in two rooms, if room temperature reached the setup temperature in one room and thermo-off occurred, the following operations start. (Refer to the figure below.)

1. The indoor unit of the room (A room) in which thermo-off did not occur starts a continuous operation with the setup number of revolution.
2. The indoor unit of the room (B room) in which thermo-off occurred starts intermittent operation of the indoor fan. The indoor fan operates with number of revolution of UL or SUL. Fan-ON time is 2 minutes and Fan-OFF time is 2 to 4 minutes.

However if temperature of the indoor heat exchanger becomes over 55°C or more in B room, the indoor fan stops the intermittent operation and starts continuous operation.

While heating operation is executed in 2 rooms, if room temperature reached the setup temperature in both rooms and thermo-off occurred, both indoor units start intermittent operation of the indoor fan.

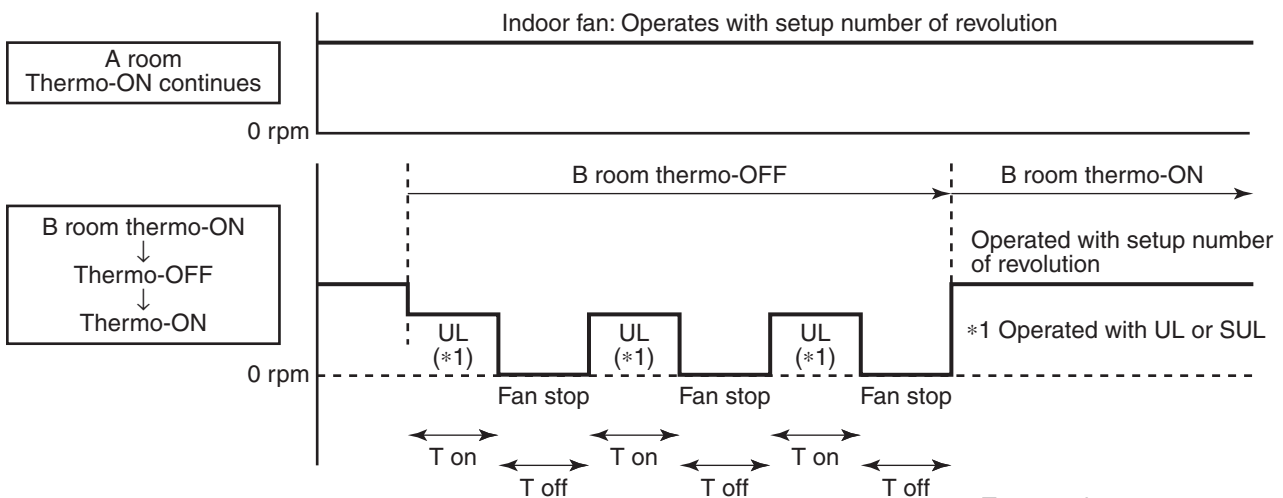

\* In case which Tc sensor temperature exceeds 55°C in B room, the fan stops intermittent operation and starts continuous operation with UL or SUL (\*1).

T on=2 min.

T off time	
To < 5°C	2 min.
5 ≤ To < 10	3 min.
10 ≤ To	4 min.

# 10. INSTALLATION PROCEDURE

## 10-1. Safety Cautions

The indoor unit shall be installed so that the top of the indoor unit is positioned at least 2 m high.  
Also, avoid putting anything on the top of the indoor unit.

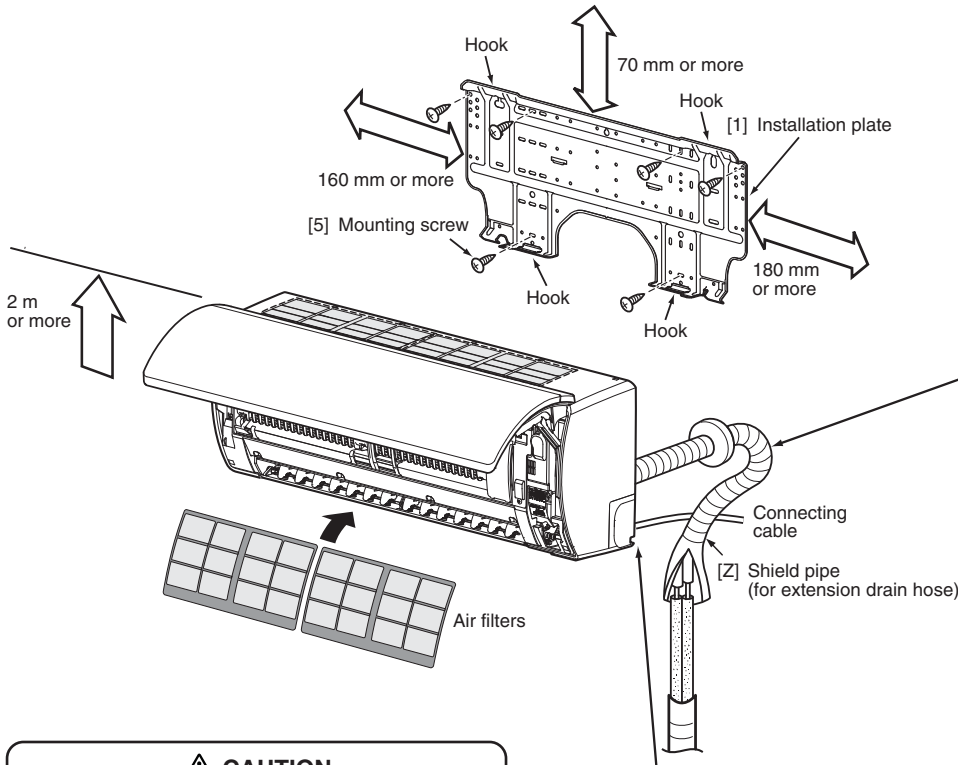

**CAUTION**  
Install in rooms that are 13 m<sup>3</sup> or larger.  
If a leak of refrigerant gas occurs inside the room, an oxygen deficiency can occur.

For the rear left and left piping

Insert the cushion between the indoor unit and wall, and tilt the indoor unit for better installation work.

Do not allow the drain hose to become slack.

Cut the piping hole slightly sloped

Make sure the drain hose is sloped downward.

The auxiliary piping can be connected at the left, rear left, rear right, right, bottom right or bottom left as shown below.

Insulate the refrigerant pipes separately, not together.

8 mm thick heat resisting polyethylene foam

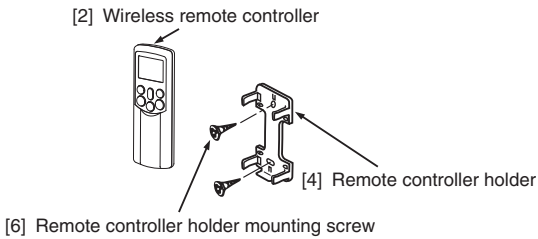

Before installing the wireless remote controller

- With the remote controller cover removed, correctly load the supplied batteries while observing their polarity.

[2] Wireless remote controller  
Cover  
[3] Batteries





- If the system will be used in cooling mode when the outdoor temperature is below zero, take measures to ensure that the drain water does not freeze.
- When the outdoor unit is installed in a place that is always exposed to strong winds like on the coast or on a high story of a building, secure the normal fan operation using a duct or a wind shield.

## 10-2. Optional Parts, Accessories and Tools

### 10-2-1. Optional Installation Parts

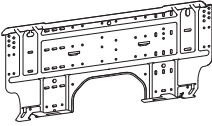
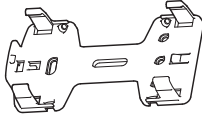
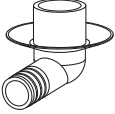
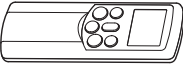
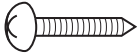
Part Code	Parts name			Q'ty
	Refrigerant piping			
[Y]	Indoor unit name	Liquid side (Outer diameter)	Gas side (Outer diameter)	1 ea.
	RAS-M10PKVP-E, RAS-M13PKVP-E	6.35 mm	9.52 mm	
	RAS-M16PKVP-E, RAS-M18PKVP-E	6.35 mm	12.7 mm	
[Z]	Shield pipe (for extension drain hose) (polyethylene foam, 8 mm thick)			1

### 10-2-2. Accessory and Installation Parts

Part No.	Part name (Q'ty)	Part No.	Part name (Q'ty)	Part No.	Part name (Q'ty)					
[1]	 Installation plate × 1	[4]	 Remote controller holder × 1	[7]	 Drain nipple * × 1					
[2]	 Wireless remote controller × 1	[5]	 Mounting screw Ø4 × 25L × 7	[8]	 Water-proof rubber cap * × 5					
[3]	 Battery × 2	[6]	 Remote controller holder mounting screw Ø3.1 × 16L × 2	Parts marked with asterisk (*) are packaged with the outdoor unit.  <b>&lt;Others&gt;</b> <table border="1" data-bbox="1054 1541 1461 1839"> <thead> <tr> <th>Name</th> </tr> </thead> <tbody> <tr> <td>Owner's manual (Indoor unit)</td> </tr> <tr> <td>Installation manual</td> </tr> <tr> <td>Important information and warning *</td> </tr> <tr> <td>B/W strips * (Energy efficiency labels)</td> </tr> </tbody> </table>		Name	Owner's manual (Indoor unit)	Installation manual	Important information and warning *	B/W strips * (Energy efficiency labels)
Name										
Owner's manual (Indoor unit)										
Installation manual										
Important information and warning *										
B/W strips * (Energy efficiency labels)										

This model is not equipped with an extension drain hose.

- For the extension drain hose, use a commercially available one.







### 10-2-3. Installation/Serviceing Tools

#### Changes in the product and components

In the case of an air conditioner using R410A, in order to prevent any other refrigerant from being charged accidentally, the service port diameter of the outdoor unit control valve (3-way valve) has been changed. (1/2 UNF 20 threads per inch)

- In order to increase the pressure resisting strength of the refrigerant piping flare processing diameter and size of opposite side of flare nuts has been changed. (for copper pipes with nominal dimensions 1/2 and 5/8)

#### New tools for R410A

New tools for R410A	Applicable to R22 model		Changes
Gauge manifold	×		As pressure is high, it is impossible to measure by means of conventional gauge. In order to prevent any other refrigerant from being charged, each port diameter has been changed.
Charge hose	×		In order to increase pressure resisting strength, hose materials and port size have been changed (to 1/2 UNF 20 threads per inch). When purchasing a charge hose, be sure to confirm the port size.
Electronic balance for refrigerant charging	○		As pressure is high and gasification speed is fast, it is difficult to read the indicated value by means of charging cylinder, as air bubbles occur.
Torque wrench (nominal diam. 1/2, 5/8)	×		The size of opposite sides of flare nuts have been increased. Incidentally, a common wrench is used for nominal diameters 1/4 and 3/8.
Flare tool (clutch type)	○		By increasing the clamp bar's receiving hole, strength of spring in the tool has been improved.
Gauge for projection adjustment	—	—	Used when flare is made by using conventional flare tool.
Vacuum pump adapter	○		Connected to conventional vacuum pump. It is necessary to use an adapter to prevent vacuum pump oil from flowing back to the charge hose. The charge hose connecting part has two ports-one for conventional refrigerant (7/16 UNF 20 threads per inch) and one for R410A. If the vacuum pump oil (mineral) mixes with R410A a sludge may occur and damage the equipment.
Gas leakage detector	×		Exclusive for HFC refrigerant.

- Incidentally, the “refrigerant cylinder” comes with the refrigerant designation (R410A) and protector coating in the U. S.’s ARI specified rose color (ARI color code: PMS 507).
- Also, the “charge port and packing for refrigerant cylinder” require 1/2 UNF 20 threads per inch corresponding to the charge hose’s port size.

### CAUTION

- Incorrect wiring connection may cause electrical parts to burn out.
- Be sure to comply with local regulations/codes when running the wire from outdoor unit to indoor unit. (Size of wire and wiring method etc.)
- Every wire must be securely connected.
- If incorrect or incomplete wiring is carried out, fire or smoke may result.
- Prepare the power supply for the exclusive use of the air conditioner.

## 10-3. Indoor Unit

### 10-3-1. Installation Place

- A place which provides enough spaces around the indoor unit as shown in the diagram.
- A place where there are no obstacle near the air inlet and outlet.
- A place which allows easy installation of the piping to the outdoor unit.
- A place which allows the front panel to be opened.
- The indoor unit shall be installed so that the top of the indoor unit is positioned at least 2m in height.
- Also, avoid putting anything on the top of the indoor unit.

### ◆ Remote controller

- Should be placed where there are no obstacles, such as curtains, that may block the signal.
- Do not install the remote controller in a place exposed to direct sunlight or close to a heating source, such as a stove.
- Keep the remote controller at least 1 m away from the nearest TV set or stereo equipment. (This is necessary to prevent image disturbances or noise interference.)
- Do not install near high-frequency devices or wireless devices.
- The location of the remote controller should be determined as shown below.

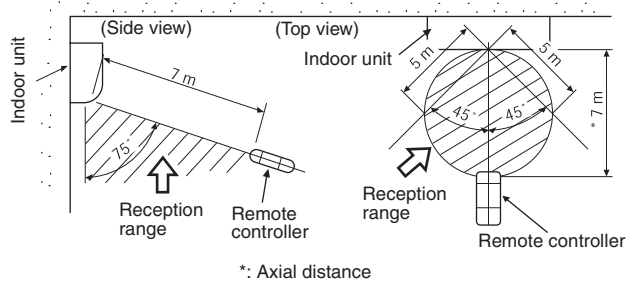

Fig. 10-3-1

### 10-3-2. Drilling and Mounting Installation Plate

#### ◆ Drilling

When installing the refrigerant pipes from the rear.

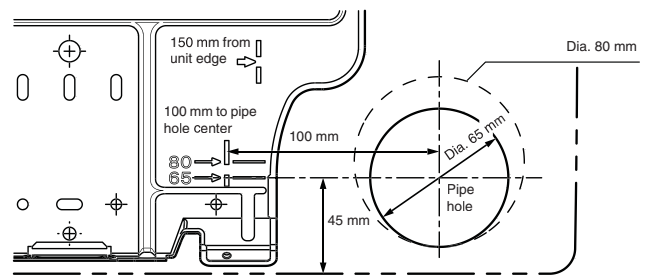

Fig. 10-3-2

- 1) Decide the installation plate mounting position on the wall.
- 2) Mark the corresponding pipe hole wall positions according to the positioning marks ( ⇔ ) on the installation plate.
- 3) Drill the pipe holes (Dia. 65 mm or Dia. 80 mm) slightly slanted downward to the outside.

#### NOTE

- When drilling into a wall that contains a metal lath, wire lath or metal plate, be sure to use a pipe hole brim ring sold separately.
- The unit is designed to enable installation using holes of 65 mm in diameter. However, if installation is difficult, make holes that are 80 mm in diameter.

#### CAUTION

Completely fill in the gaps in the pipe holes with noncombustible material (such as putty) to prevent condensation and fire in the casing.

#### ◆ Mounting the installation plate

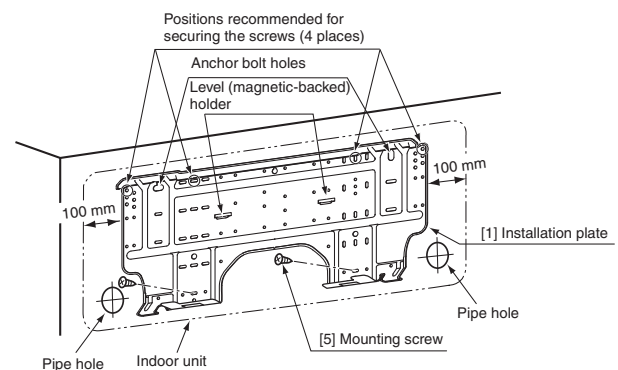

Fig. 10-3-3

### ◆ Mounting the installation plate directly on a wall

- 1) Securely fit the installation plate onto the wall by screws with the upper and lower catches.
- 2) To mount the installation plate on a concrete wall use anchor bolts. Drill the anchor bolt holes as illustrated in the above figure.
- 3) Place the level at the top end of the installation plate, and check that the plate is horizontal.

### CAUTION

When installing the installation plate with mounting screws, do not use anchor bolt holes.

Otherwise the unit may fall down and result in personal injury and property damage.

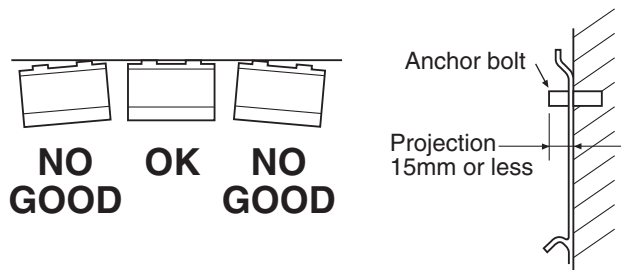

Fig. 10-3-4

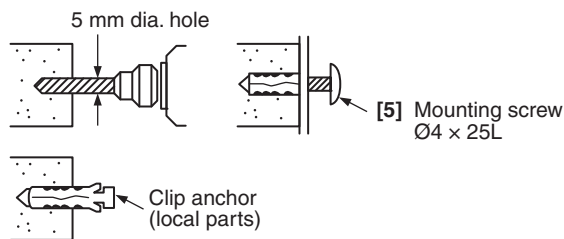

Fig. 10-3-5

### CAUTION

Failure to securely install the unit may result in personal injury and/or property damage if the unit falls.

- In case of block, brick, concrete or similar type walls, drill 5 mm dia. holes in the wall.
- Insert clip anchors for the [5] mounting screws.

### NOTE

Install the installation plate using between 4 to 6 mounting screws, making sure all four corners are secure.

### 10-3-3. Electrical Work

1. The supply voltage must be the same as the rated voltage of the air conditioner.
2. Prepare a power source for the exclusive use of the air conditioner.

### NOTE

- Wire type: H07RN-F or 60245IEC66 (1.0 mm<sup>2</sup>)
- Make sure the wire length is sufficient before performing wiring work.



## 10-3-4. Wiring Connection

### ◆ Connecting cable

Wiring the connecting cable can be carried out without removing the front panel.

1. Remove the air inlet grille.  
Open the air inlet grille upward and pull it toward you.
2. Remove the terminal cover and cord clamp.
3. Insert the connecting cable (or as according to local regulations/codes) into the pipe hole on the wall.
4. Pull the connecting cable through the cable slot on the rear panel so that it protrudes about 15 cm out of the front.
5. Insert the connecting cable fully into the terminal block and secure it tightly with screws.  
Make a loop with the earth wire under the terminal block and secure it with the earth screw.
6. Tightening torque: 1.2 N•m (0.12 kgf•m)
7. Secure the connecting cable with the cord clamp.
8. Attach the terminal cover and moving panel on the indoor unit.

### CAUTION

- Be sure to refer to the wiring system diagram labelled inside the front panel.
- Check local electrical regulations for any specific wiring instructions or limitations.

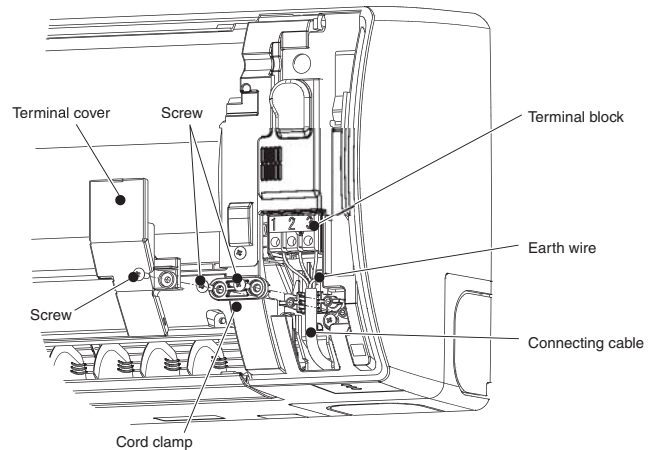

Fig. 10-3-6

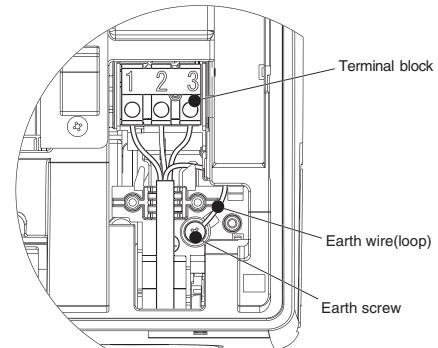

Fig. 10-3-7

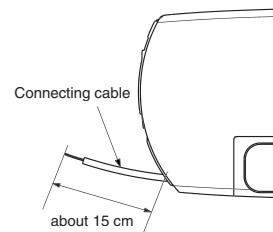

Fig. 10-3-8

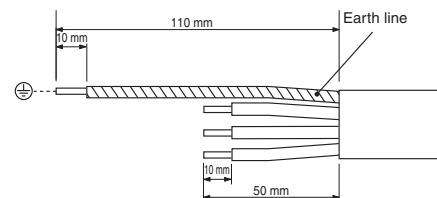

Fig. 10-3-9

### NOTE

- Connecting cable (Indoor unit/outdoor unit)
- Wire type: H07RN-F or 60245IEC66 (1.0 mm<sup>2</sup>)

## 10-3-5. Piping and Drain Hose Installation

### ◆ Piping and drain hose forming

Since condensation results in machine trouble, make sure to insulate both the connecting pipes separately.

(Use polyethylene foam as insulating material.)

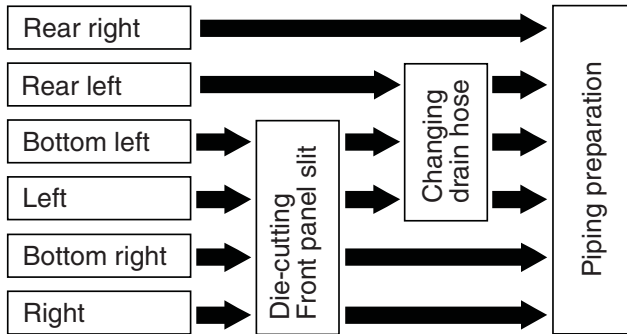

Fig. 10-3-10

### ◆ Relocating drain hose

For left connection, left-bottom connection and rear-left connection's piping, it is necessary to relocate the drain hose and drain cap.

#### 1) Cutting front panel slit.

Cut out the slit on the left or right side of the front panel for the left or right connection and the slit on the bottom left or right side of the front panel for the bottom left or right connection with a pair of nippers.

#### 2) Remove the drain cap

Clamp drain cap with needle-nose pliers, and pull out.

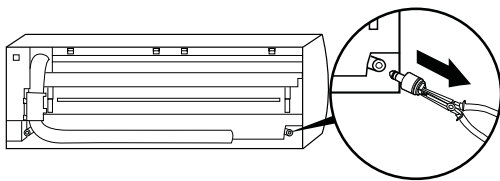

Fig. 10-3-11

#### 3) Remove the drain hose

The drain hose is secured in place by a screw. Remove the screw securing the drain hose, then pull out the drain hose.

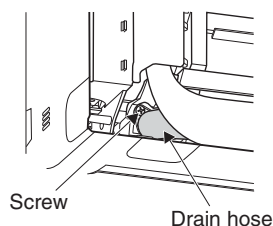

Fig. 10-3-12

#### 4) Attach the drain cap

- Insert hexagonal wrench (4 mm).

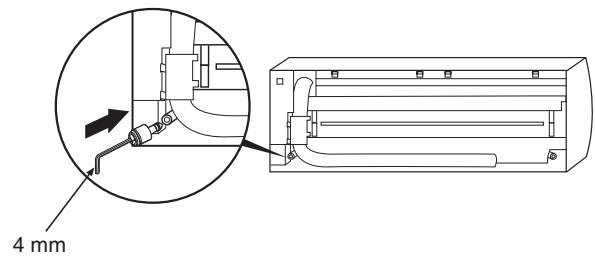

Fig. 10-3-13

#### 5) Firmly insert drain cap.

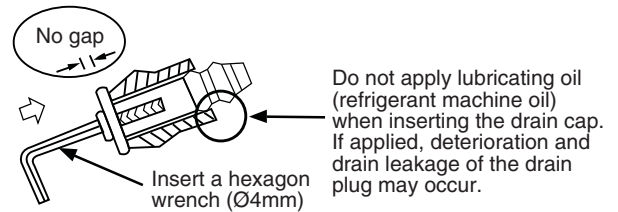

Fig. 10-3-14

#### 6) Attach the drain hose

Insert the drain hose firmly until the connector contacts with the insulation, then secure it in place using the original screw.

**Always use the original screw that secured the drain hose to the unit. If using a different screw may cause water to leak.**

### ⚠ CAUTION

Securely insert the drain hose and drain cap; otherwise, water may leak.

### NOTE

The packaged foam polystyrene can be used to make replacement of the drain cap and drain hose easier.

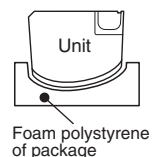

### ◆ Piping on the right side or the left side

- After making slits on the front panel with a knife or similar tool, cut them out with a pair of nippers or an equivalent tool.

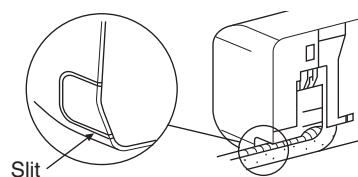

Fig. 10-3-15

◆ **Piping on the bottom right or the bottom left**

- After making slits on the front panel with a knife or similar tool, cut them out with a pair of nippers or an equivalent tool.

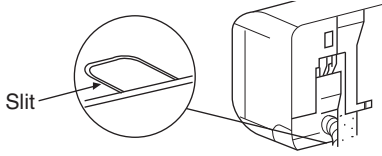

Fig. 10-3-16

◆ **Left-hand connection with piping**

Bend the connecting pipes so that they are positioned within 43 mm above the wall surface. If the connecting pipes are positioned more than 43 mm above the wall surface, the indoor unit may be unstable.

When bending the connecting pipe, make sure to use a spring bender to avoid crushing the pipe.

**Refer to the table below for the bending radius of each connection pipe.**

Outer diameter	Bending radius
6.35 mm	30 mm
9.52 mm	40 mm
12.7 mm	50 mm

**Connect the pipe after installation of the unit (figure)**

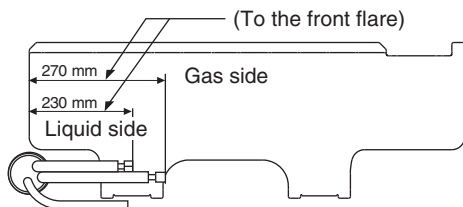

R30 or less (Dia. 6.35), R40 or less (Dia. 9.52), R50 or less (Dia. 12.7)  
Make sure to use a spring bender to avoid crushing the pipe.

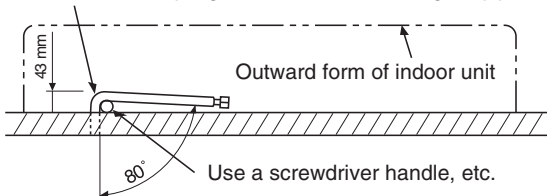

Fig. 10-3-17

**NOTE**

If the pipe is incorrectly bent, the indoor unit may be unstable on the wall.

After passing the connecting pipe through the pipe hole, connect the connecting pipe to the auxiliary pipes and wrap the facing tape around them.

**CAUTION**

- Bind the auxiliary pipes (two) and connecting cable with facing tape tightly.  
In case of leftward piping and rear-leftward piping, bind the auxiliary pipes (two) only with facing tape.

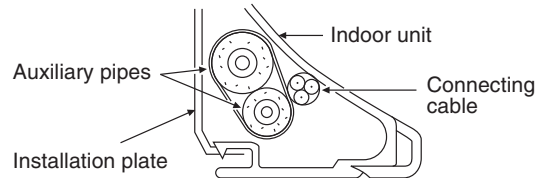

Fig. 10-3-18

- Carefully arrange the pipes so that none of the pipes stick out of the rear plate of the indoor unit.
- Carefully connect the auxiliary pipes and connecting pipes to each other and cut off the insulating tape wound on the connecting pipe to avoid double-taping at the joint, moreover, seal the joint with the vinyl tape, etc.
- Since condensation can result in machine performance trouble, be sure to insulate both connecting pipes.  
(Use polyethylene foam as insulating material.)
- When bending a pipe, be careful not to crush it.

### 10-3-6. Indoor Unit Installation

1. Pass the pipe through the hole in the wall, and hook the indoor unit on the installation plate at the upper hooks.
2. Swing the indoor unit to right and left to confirm that it is firmly hooked on the installation plate.
3. While pushing the indoor unit onto the wall, hook it at the lower part on the installation plate.  
Pull the indoor unit toward you to confirm that it is firmly hooked on the installation plate.
4. Pull the connecting cable through the cable slot on the rear panel so that it protrudes about 15 cm out of the front.

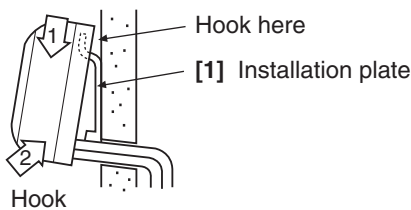

Fig. 10-3-19

- For detaching the indoor unit from the installation plate pull the indoor unit toward you while pushing the bottom up at the specified places.

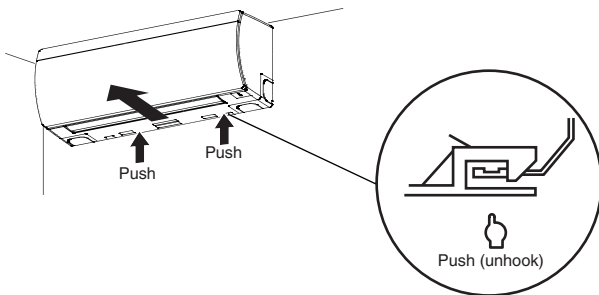

Fig. 10-3-20

### 10-3-7. Drainage

1. Run the drain hose at a downward sloped angle.

#### NOTE

- Hole should be made at a slight downward slant on the outdoor side.

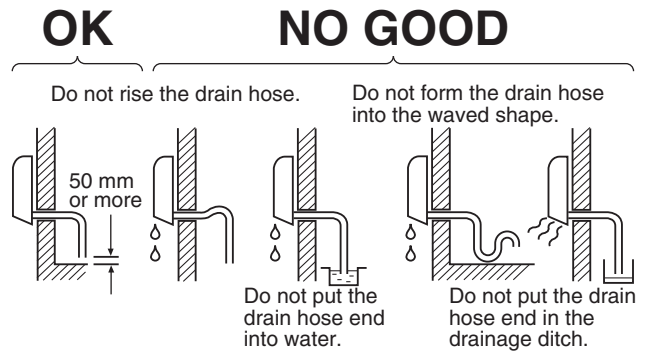

Fig. 10-3-21

2. Put water in the drain pan and make sure that the water is being drained outside.
3. When connecting extension drain hose, insulate the connection part of extension drain hose with shield pipe.

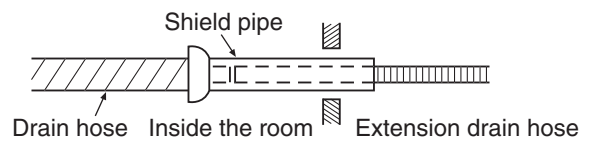

Fig. 10-3-22

#### CAUTION

Install the drain pipe for proper drainage. Improper drainage can result in water dripping inside the room.

This air conditioner has been designed to drain water collected from condensation which forms on the back of the indoor unit, to the drain pan.

Therefore, do not locate the power cord and other parts at a high place above the drain guide.

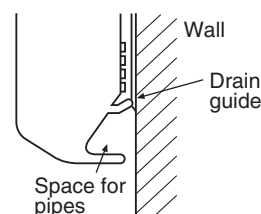







Fig. 10-3-23

## 10-4. Outdoor Unit

### 10-4-1. Accessory and Installation Parts

Installation manual	1		Rubber cap (Water-proof)	5		CD-ROM (Installation manual)	1	
F-GAS label	1		Drain nipple	1				

### 10-4-2. Refrigerant Piping

- Piping kit used for the conventional refrigerant cannot be used.
- **Use copper pipe with 0.8 mm or more thickness.**
- Flare nut and flare works are also different from those of the conventional refrigerant. Take out the flare nut attached to the main unit of the air conditioner, and use it.

### 10-4-3. Installation Place

- A place which provides the spaces around the outdoor unit.
- A place where the operation noise and discharged air do not disturb your neighbors.
- A place which is not exposed to a strong wind.
- A place which does not block a passageway.
- When the outdoor unit is to be installed in an elevated position, be sure to secure its feet.
- There must be sufficient spaces for carrying the unit into and out of the site.
- A place where the drain water does not raise any problem.
- A place which can bear the weight of the outdoor unit and does not allow an increase in noise level and vibration.

### CAUTION

1. Install the outdoor unit without anything blocking the air discharging.
2. When the outdoor unit is installed in a place exposed always to a strong wind like a coast or on a high story of a building, secure the normal fan operation using a duct or a wind shield.
3. Especially in windy area, install the unit to prevent the admission of wind.

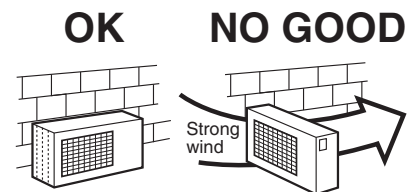

Fig. 10-4-1

4. Installation in the following places may result in trouble. Do not install the unit in such places.
  - A place full of machine oil.
  - A place full of sulfide gas.
  - A place where high-frequency waves are likely to be generated as from audio equipment, welders, and medical equipment.
  - A saline-place such as a coast.

### 10-4-4. Optional Installation Parts (Local Supply)

Parts name	Parts name			Q'ty
	Indoor unit (abbreviation)	Liquid side (O.D.)	Gas side (O.D.)	
Refrigerant piping *1	07, 10, 13	6.35 mm	9.52 mm	1 ea.
	16, 18	6.35 mm	12.7 mm	
Putty, PVC tapes				1 ea.

- \*1 Refrigerant piping covered with insulating material (Polyethylene form, 6 mm thick).  
When duct-type or cassette-type unit is to be installed, it shall be covered with thicker insulating material (Polyethylene form, 10 mm thick).

## 10-4-5. Installation

### NOTE

For installation, at least 3 dimensions should be kept free from obstacles (walls).

### Necessary space for installation

If you need to install the outdoor unit in a location where there are some obstructions or a wall, secure sufficient space as shown in the figure below.

The cooling/heating effect may be reduced by 10%.

#### Upper side view (Unit: mm)

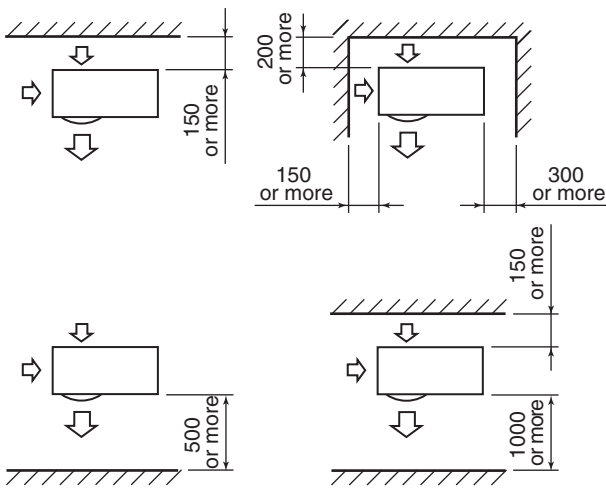

Fig. 10-4-2

#### Side view (Unit: mm)

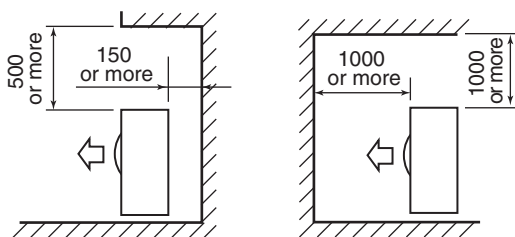

Fig. 10-4-3

### Fixing bolt arrangement of outdoor unit

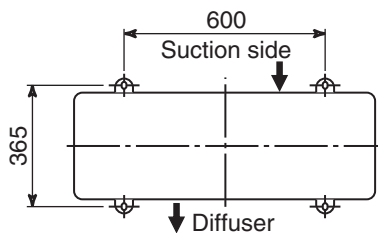

Fig. 10-4-4

- Secure the outdoor unit with the fixing bolts and nuts if the unit is likely to be exposed to a strong wind.
- Use Ø8 mm or Ø10 mm anchor bolts and nuts.

1. Piping connections to the outdoor unit should be arranged in the sequence A, B, C, D, E starting from the bottom.

(For each piping connection, the gas pipe is on the bottom and the liquid pipe is on the top.)

2. When multiple indoor units are to be connected to the outdoor unit, make the ends of the pipes and wires from each indoor unit to ensure that they will be connected to the outdoor unit correctly. (Problems caused by indoor units being connected to the outdoor unit incorrectly are very common in multiple-unit installations.)
3. The length and height difference of the connecting pipes between the indoor and outdoor units must be within the ranges indicated below.

- Total piping length :

Non. Additional refrigerant .....	40 m
Additional refrigerant .....	80 m
.....	41 to 80 m
Additional 20 g of refrigerant.....	Per every 1 m

- Minimum piping length :  
A or B or C or D or E = 3 m or more
- Maximum indoor piping length :  
A or B or C or D or E = 25 m or less
- Maximum piping height difference :  
A or B or C or D or E = 15 m or less
- Maximum piping/height difference between 2 units = 15 m or less

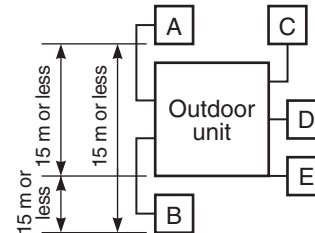

Fig. 10-4-5

4. Connect 2 or more indoor units for heat pump.
5. If the outdoor units is to be mounted on a wall, make sure that the platform supporting it is sufficiently strong.

The platform should be designed and manufactured to maintain its strength over a long period of time, and sufficient consideration should be given to ensuring that the outdoor unit will not fall.

6. When the outdoor unit is to be mounted high on a wall, take particular care to ensure that parts do not fall installer is protected.
7. When doing installation work on level ground, it is usual to wiring and piping connections to the indoor units. And/then make to the outdoor unit. However if outdoor work is difficult it is possible instead to make changes to the procedure.

For example by making adjustments to the wiring and piping length on the inside (rather than the outside).

### ◆ How to remove the front panel

1. Remove 5 screws of the front panel.
2. Pull the front panel downward.

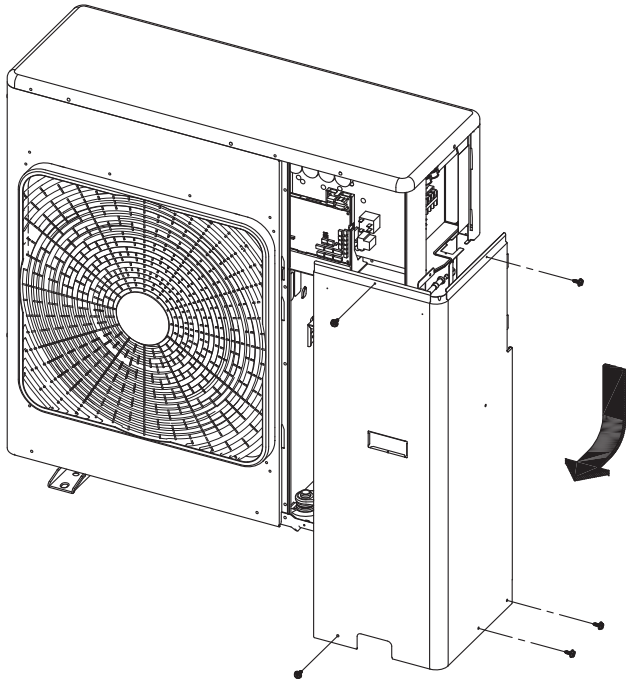

Fig. 10-4-6

### ◆ Tightening connection

Align the centers of the connecting pipes and tighten the flare nut as far as possible with your fingers.

Then tighten the nut with a spanner and torque wrench as shown in the figure.

#### ⚠ CAUTION

- Do not apply excess torque. Otherwise, the nut may break.

(Unit : N·m)

Outer dia. of copper pipe	Tightening torque
Ø6.35 mm	14 to 18 (1.4 to 1.8 kgf·m)
Ø9.52 mm	33 to 42 (3.3 to 4.2 kgf·m)
Ø12.7 mm	50 to 62 (5.0 to 6.2 kgf·m)

### • Tightening torque of flare pipe

The pressure of R410A is higher than R22. (Approx. 1.6 times)

Therefore securely tighten the flare pipes which connect the outdoor unit and indoor unit with the specified tightening torque using a torque wrench.

If any flare pipe is incorrectly connected, it may cause not only a gas leakage but also trouble in the refrigeration cycle.

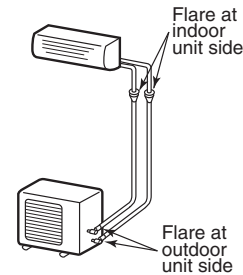
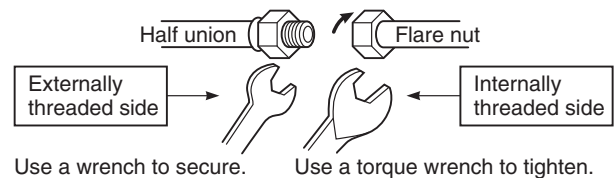

Fig. 10-4-7



Use a wrench to secure. Use a torque wrench to tighten.

Fig. 10-4-8

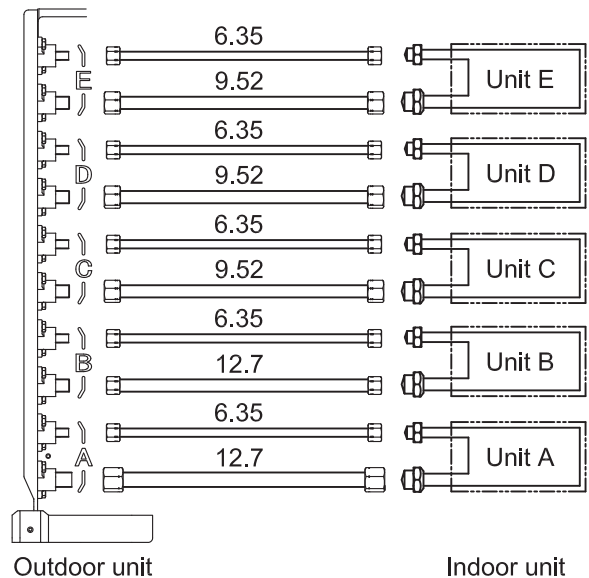

Fig. 10-4-9

Connectable capacity class					Total
A	B	C	D	E	
07, 10, 13 (with reducer)		16, 18 (with expander)			68
16, 18		07, 10, 13			



## 10-4-6. Refrigerant Piping Connection



**CAUTION**

### KEEP IMPORTANT 4 POINTS FOR PIPING WORK

1. Keep dust and moisture from entering the pipes.
2. Tight connection (between pipes and unit)
3. Evacuate the air in the connecting pipes using VACUUM PUMP.
4. Check gas leak. (connected points)

### ◆ Flaring

1. Cut the pipe with a pipe cutter.

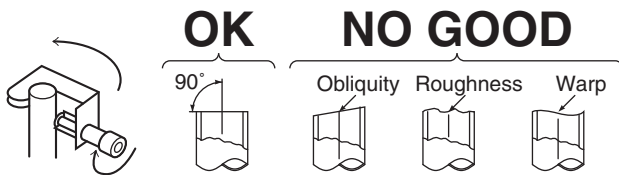

Fig. 10-4-10

2. Insert a flare nut into the pipe, and flare the pipe. As the flaring sizes of R410A differ from those of refrigerant R22, the flare tools newly manufactured for R410A are recommended. However, the conventional tools can be used by adjusting projection margin of the copper pipe.

### • Projection margin in flaring : B (Unit : mm)

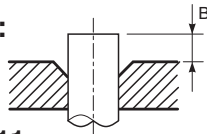

Fig. 10-4-11

Rigid (Clutch type)

Outer dia. of copper pipe	R410A tool used		Conventional tool used	
	R410A	R22	R410A	R22
6.35	0 to 0.5	(Same as left)	1.0 to 1.5	0.5 to 1.0
9.52	0 to 0.5	(Same as left)	1.0 to 1.5	0.5 to 1.0
12.7	0 to 0.5	(Same as left)	1.0 to 1.5	0.5 to 1.0

Imperial (Wing nut type)

Outer dia. of copper pipe	R410A	R22
6.35	1.5 to 2.0	1.0 to 1.5
9.52	1.5 to 2.0	1.0 to 1.5
12.7	2.0 to 2.5	1.5 to 2.0

### • Flaring size : A (Unit : mm)

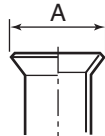

Fig. 10-4-12

Outer dia. of copper pipe	A $\pm 0.4$	
	R410A	R22
6.35	9.1	9.0
9.52	13.2	13.0
12.7	16.6	16.2

\* In the case of flaring for R410A with the conventional flare tool, pull out it approx. 0.5 mm more than that for R22 to adjust to the specified flare size. The copper pipe gauge is useful for adjusting projection margin size.

## 10-4-7. Evacuating

After the piping has been connected to all indoor unit(s), you can perform the air purge together at once.

### AIR PURGE

Evacuate the air in the connecting pipes and in the indoor unit using vacuum pump.

Do not use the refrigerant in the outdoor unit. For details, see the manual of vacuum pump.

### ◆ Use a vacuum pump

Be sure to use a vacuum pump with counter-flow prevention function so that inside oil of the pump does not flow backward into pipes of the air conditioner when the pump stops.

(If inside oil of the vacuum pump enters into the air conditioner which adopts R410A, a trouble of the refrigeration cycle may be caused.)

1. Connect the charge hose from the manifold valve to the service port of the gas side packed valve.
2. Connect the charge hose to the port of vacuum pump.
3. Open fully the low pressure side handle of the gauge manifold valve.
4. Operate the vacuum pump to start for evacuating. Perform evacuating for about 40 minutes if the piping length is total 80 meters. (assuming a pump capacity of 27 liters per minute.) Then confirm that the compound pressure gauge reading is  $-101 \text{ kPa}$  ( $-76 \text{ cmHg}$ ).
5. Close the low pressure side valve handle of gauge manifold.
6. Open fully the valve stem of the packed valves (both sides of Gas and Liquid).
7. Remove the charging hose from the service port.
8. Securely tighten the caps on the packed valves.

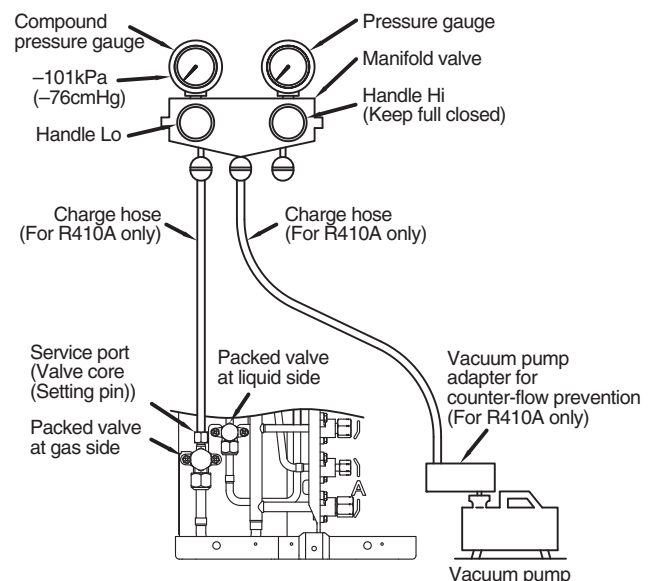

Fig. 10-4-13

## ◆ Packed valve handling precautions

- Open the valve stem all the way out ; do not try to open it beyond the stopper.
- Securely tighten the valve stem cap in torque is as follows :

Gas side (Ø12.7 mm)	50 to 62 N•m (5.0 to 6.2 kgf•m)
Gas side (Ø9.52 mm)	33 to 42 N•m (3.3 to 4.2 kgf•m)
Liquid side (Ø6.35 mm)	14 to 18 N•m (1.4 to 1.8 kgf•m)
Service port	14 to 18 N•m (1.4 to 1.8 kgf•m)

Hexagonal wrench is required.

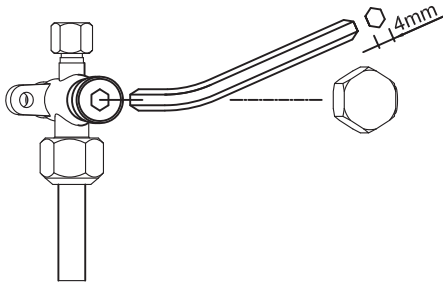

Fig. 10-4-14

## 10-4-8. Electrical Work

For the air conditioner that has no power cord, connect a power cord to it as mentioned below.

Model	5 Units Multi
	5M34UAV-E
Power supply	220 – 240 V, ~50 Hz 240 V, ~60 Hz
Maximum running current	19.5 A
Installation fuse rating	20 A breaker or fuse (All types can be used.)
Power cord	H07 RN-F or 245 IEC 66 (2.5 mm <sup>2</sup> or more)

## ◆ Wiring connection

1. Remove the front panel and cord clamp from the outdoor unit.
2. Connect the connecting cable to the terminal as identified by the matching numbers on the terminal block of indoor and outdoor unit.
3. Insert the power cord and the connecting cable fully into the terminal block and secure it tightly with screws.
4. Insulate the unused cords (conductors) from water entering in the outdoor unit. Locate them so that they do not touch any electrical or metal parts.
5. Secure the power cord and the connecting cable with the cord clamp.
6. Attach the front panel on the outdoor unit.

## 3 units (A + B + C) Multi

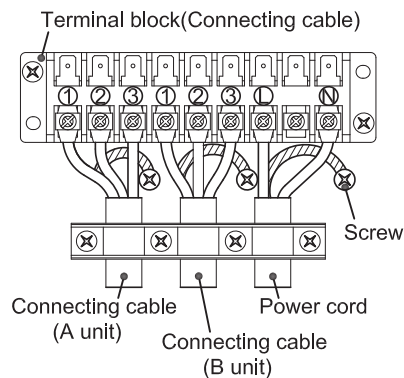

Fig. 10-4-15

## 5 units (A + B + C + D + E) Multi

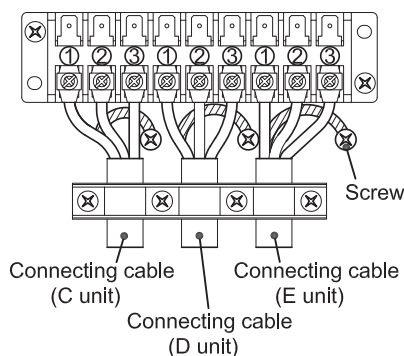

Fig.10-4-16

## CAUTION

- Wrong wiring connection may cause some electrical parts burn out.
- Be sure to use the cord clamps specified positions with attached to the product.
- Do not damage or scratch the conductive core and inner insulator of power and inter-connecting cables when peeling them.
- Be sure to comply with local cords on running the wire from outdoor unit to indoor unit (size of wire and wiring method etc.)
- Use the power cord and Inter-connecting cable with specified thickness, specified type, and protective devices specified.

## ◆ Stripping length power cord and connecting cable

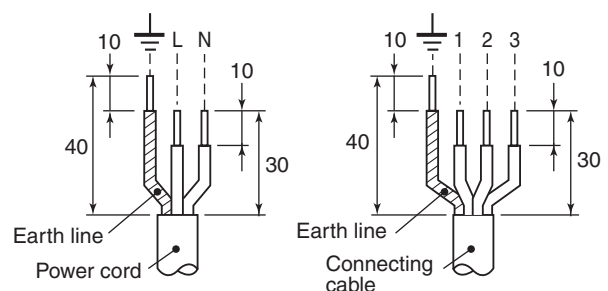

Fig. 10-4-17

## 10-4-8. Check and Test Operation

For R410A, use the leak detector exclusively manufactured for HFC refrigerant (R410A, R134a, etc.).

- \* The conventional leak detector for HCFC refrigerant (R22, etc.) cannot be used because its sensitivity for HFC refrigerant lowers to approx. 1/40.
- Pressure of R410A becomes approx. 1.6 times of that of R22. If installation work is incompletely finished, a gas leakage may occur in the cases such as pressure rise during operation. Therefore, be sure to test the piping connections for leaking.

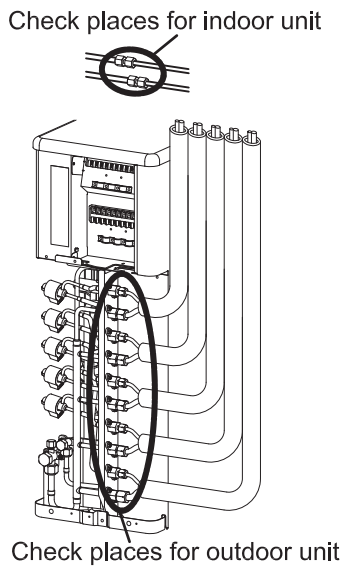

Fig. 10-4-18

- Check the flare nut connections, valve stem cap connections and service port cap connections for gas leak with a leak detector or soap water.

### CAUTION

- Use a circuit breaker of a type that is not tripped by shock waves.
- If incorrect/incomplete wiring is carried out, it will cause an electrical fire or smoke.
- Prepare the power supply for exclusive use with the air conditioner.
- This product can be connected to the mains.

Connection to fixed wiring :

A switch or circuit breaker which disconnects all poles and has a contact separation of at least 3 mm must be incorporate in the fixed wiring. An approved short circuit breaker or switches must be used.

- \* (A breaker having a sensitivity of approximately 0.1 second or less and a capacity of approximately 30 mA is usually used.)

## 10-4-9. Miswiring (Mispiping) Check

Make sure that the wiring and piping for each room have the same alphabetical codes (A, B, C, D, E).

Connect and secure the power cord.

Use the power cord/cables with thickness, type and protective devices specified in this manual.

Insulate the unused cords (conductors) with PVC tape.

1. Detach the front panel of the outdoor unit.  
Do not remove the air discharge grille.
2. Turn on the circuit breaker to supply electricity.
3. Start running all the indoor units connected to the outside unit in the cooling mode.
  - You need not specify the temperature setting of the indoor units.
  - You cannot check wiring/piping when the external temperature is 5°C or less.
4. Turn on the SW802 No.4 switch on the P.C. board MCC 5071.

The wiring / piping check starts automatically.

While checking, each LED flashes consecutively to indicate that the checking each indoor unit is in progress.

When checking is complete, the check result is displayed on the LED panel.

See the table below for details.

- 4-1. If no problems are detected.

The checking operation returns to the normal operation automatically.

The compressor stops temporarily, then it restarts.

The D801 LED flashes while the compressor is stopped.

- 4-2. If incorrect wiring/piping is detected.

The checking operation stops.

Check the status of the LED to confirm the details of the problem.

Turn off the circuit breaker, then check wiring/piping again.

5. Turn off SW802 No.4 switch on the P.C. board MCC 5071.

- The checking operation changes to the normal operation.

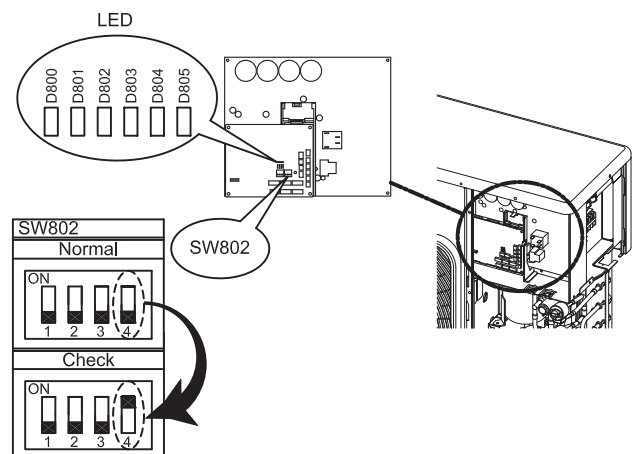

Fig. 10-4-19

☒ : LED ON, ● : LED OFF, ◎ : LED Flash

	LED						Description
	D800	D801	D802	D803	D804	D805	
Before check	☒	●	●	●	●	●	Normal operation (no error)
During check	◎	◎	●	●	●	●	Checking A unit
	◎	●	◎	●	●	●	Checking B unit
	◎	●	●	◎	●	●	Checking C unit
	◎	●	●	●	◎	●	Checking D unit
	◎	●	●	●	●	◎	Checking E unit
Check results	☒	●	●	●	●	●	Normal operation (no error)
	◎	☒	●	●	●	●	Trouble in unit A
	◎	●	☒	●	●	●	Trouble in unit B
	◎	●	●	☒	●	●	Trouble in unit C
	◎	●	●	●	☒	●	Trouble in unit D
	◎	●	●	●	●	☒	Trouble in unit E
	◎	☒	☒	●	●	●	Trouble in unit A and B
	◎	☒	●	☒	●	●	Trouble in unit A and C
	◎	☒	●	●	☒	●	Trouble in unit A and D
	◎	☒	●	●	●	☒	Trouble in unit A and E
	◎	●	☒	☒	●	●	Trouble in unit B and C
	◎	●	☒	●	☒	●	Trouble in unit B and D
	◎	●	☒	●	●	☒	Trouble in unit B and E
	◎	●	●	☒	☒	●	Trouble in unit C and D
	◎	●	●	☒	●	☒	Trouble in unit C and E
	◎	●	●	●	☒	☒	Trouble in unit D and E
	◎	☒	☒	☒	●	●	Trouble in unit A,B and C
	◎	☒	☒	●	☒	●	Trouble in unit A,B and D
	◎	☒	☒	●	●	☒	Trouble in unit A,B and E
	◎	☒	●	☒	☒	●	Trouble in unit A,C and D
	◎	☒	●	☒	●	☒	Trouble in unit A,C and E
	◎	☒	●	●	☒	☒	Trouble in unit A,D and E
	◎	●	☒	☒	☒	●	Trouble in unit B,C and D
	◎	●	☒	☒	●	☒	Trouble in unit B,C and E
	◎	●	☒	●	☒	☒	Trouble in unit B,D and E
	◎	●	●	☒	☒	☒	Trouble in unit C,D and E
	◎	☒	☒	☒	☒	●	Trouble in unit A,B,C and D
	◎	☒	☒	☒	●	☒	Trouble in unit A,B,C and E
	◎	☒	☒	●	☒	☒	Trouble in unit A,B,D and E
	◎	☒	●	☒	☒	☒	Trouble in unit A,C,D and E
◎	●	☒	☒	☒	☒	Trouble in unit B,C,D and E	
◎	☒	☒	☒	☒	☒	"Trouble in all units service valve stays closed"	

## 10-5. Test Operation

### 10-5-1. Gas Leak Test

Check the flare nut connections for gas leaks with a gas leak detector and/or soapy water.

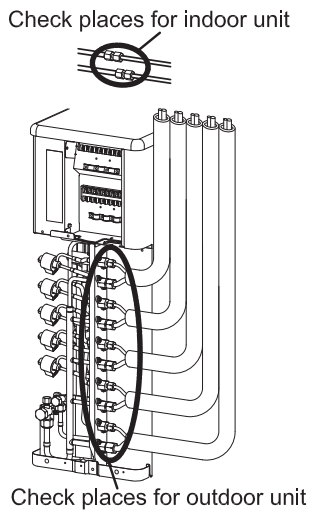

Fig. 10-5-1

### 10-5-2. Test Operation

To test the system, push and hold RESET button for 10 sec. (There will be one short beep.)

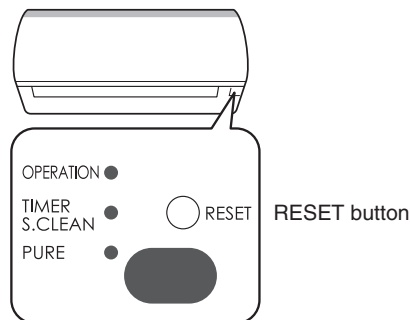

Fig. 10-5-2

### 10-5-3. Setting the Auto Restart

This product is designed so that, after a power failure, it can restart automatically in the same operating mode as before the power failure.

#### NOTE

The product was shipped with Auto Restart function in the OFF position. Turn it ON as required.

- 1) Push and hold the RESET button for about 3 seconds.  
After 3 seconds, three short electric beeps will be heard to inform you that the Auto Restart has been selected.
- 2) To cancel the Auto Restart, follow the steps described in the section Auto Restart Function of the Owner's Manual.

### 10-5-4. Select Switch on Remote Controller

- If two indoor units are installed in the same room or adjoining rooms, when the user tries to operate only one unit, both units may receive the same remote controller signal and operate.

This can be prevented by changing one of the indoor units and remote controllers to setting "B" (the default setting for both units is "A").

- If the indoor unit and remote controller settings are different, the remote controller signal is not accepted.

#### Setting the remote controller

- 1) Slide open the remote controller cover and remove the batteries.
- 2) Cut the jumper wire inside the battery compartment using nippers.

#### NOTE

The jumper wire should not remain in contact after being cut. Also, be careful not to let plastic scraps, jumper wire cuttings or other debris enter the inside of the remote controller.

- 3) Insert the batteries.  
"B" appears in the remote controller display.

#### Setting the unit

- 1) Push the RESET button to start automatic operation.
- 2) Push the  button of the remote controller that was set in step 1 to stop the air conditioner. (This operation will change the setting to "B".)
- 3) Check that the remote controller operates the indoor unit.

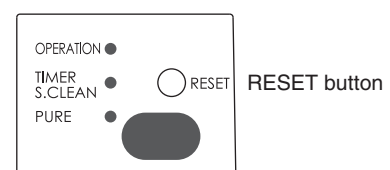
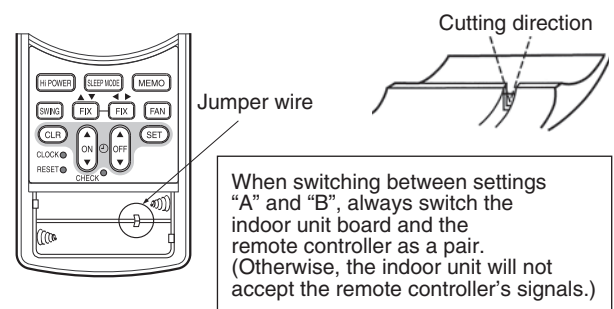

Fig. 10-5-3



## 10-6. Removing the Main Parts

Normally, the front panel, moving panel, and air flow louvres do not need to be removed.

However, use the procedure below if removal of these parts is necessary.

### CAUTION

Before removing the front panel, moving panel, or air flow louvres, be sure to stop operation of the air conditioner and unplug the power supply.

#### 10-6-1. Removing the Front Panel and Moving Panel

- 1) Open the moving panel, and support the moving panel by the panel support on the right side.

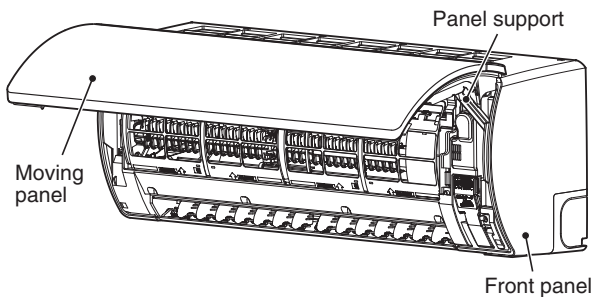

Fig. 10-6-1

- 2) Remove the 4 set screws on the front panel.

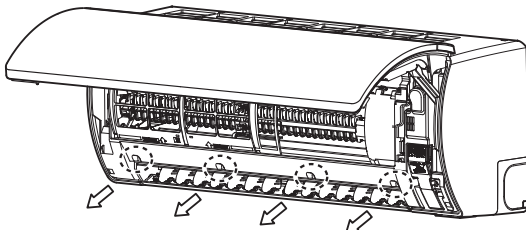

Fig. 10-6-2

- 3) Insert your thumb into the air outlet bottom section, and lift up the front panel bottom.
- 4) Close the moving panel to remove the clips on the top side as shown below.

Push your finger down on the clip on the front panel top, and lift up the panel back edge so that the clip is released (5 locations).

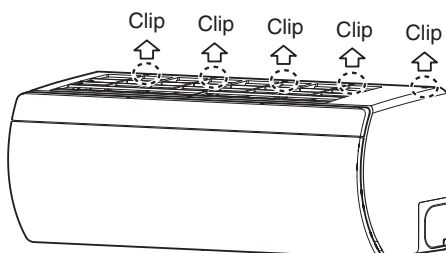

Fig. 10-6-3

#### 10-6-2. Removing the Moving Panel

- 1) Open the moving panel, and support the moving panel by the panel support on the right side.
- 2) Remove the lead wire cover on the right side. (1 screw)

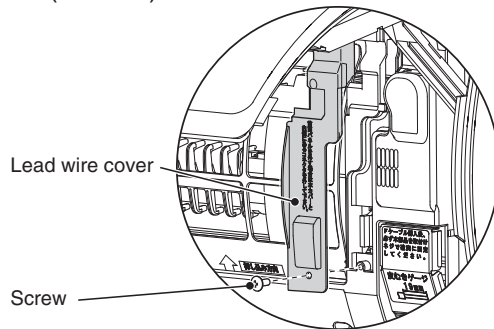

Fig. 10-6-4

- 3) After removing a screw of the left-side panel stopper, slide the panel stopper downwards.

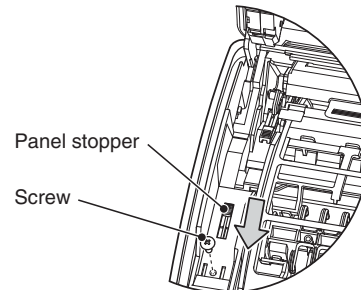

Fig. 10-6-5

- 4) Grasp both sides of the moving panel, return the panel support to its original position, and push the left-side arm inwards with your finger.

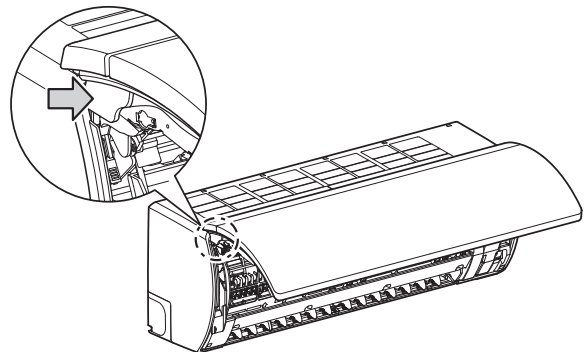

Fig. 10-6-6

- 5) Pull out the moving panel towards the left side to remove.

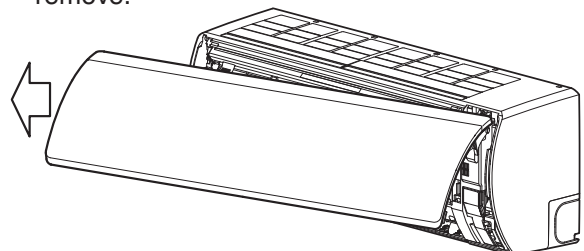

Fig. 10-6-7

### 10-6-3. Attaching the Moving Panel

- 1) Grasp both sides of the moving panel, and insert the right-side joint first.

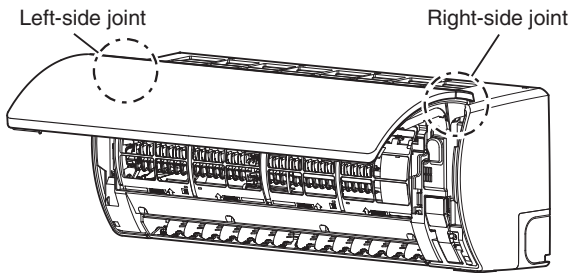

Fig. 10-6-8

- 2) Insert the left-side joint, raise the panel stopper upwards, and secure with the screw.

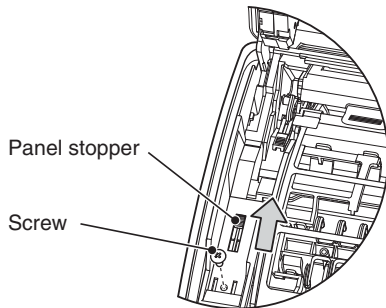

Fig. 10-6-9

- 3) Insert the top edge of the lead wire cover into the front panel, and secure with a screw.

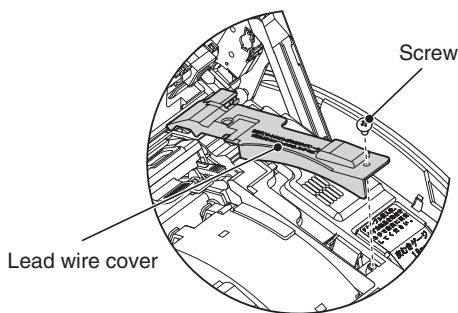

Fig. 10-6-10

### 10-6-4. Removing the Vertical Air Flow Louver

#### CAUTION

The horizontal air flow louvres cannot be released from the vertical air flow louver.

- 1) Open the moving panel, and support it with the panel support.
- 2) Open the vertical air flow louver.

- 3) Insert a flathead screwdriver into the gap of the louver fixture on the right and left ends of the vertical air flow louver, and turn in the counter-clockwise direction to remove.

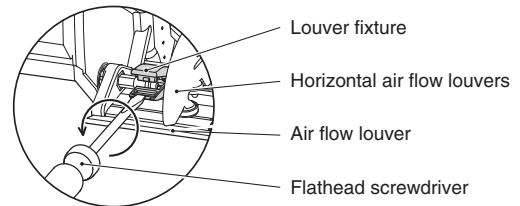

Removing the louver fixture (Left side)

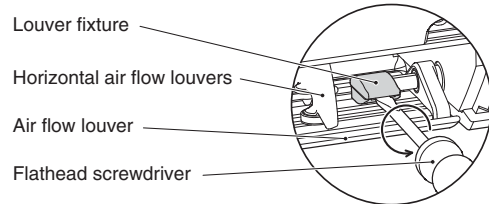

Removing the louver fixture (Right side)

Fig. 10-6-11

- 4) After pushing in the right and left connector joints, remove the vertical air flow louvres. Push in the right-side joint first before pushing in the left-side joint.

### 10-6-5. Attaching the Vertical Air Flow Louvres

- 1) Attach the vertical air flow louvres by inserting the connector joints in the order of left, right, and centre.
- 2) Secure the horizontal air flow louvres to the connector joints.

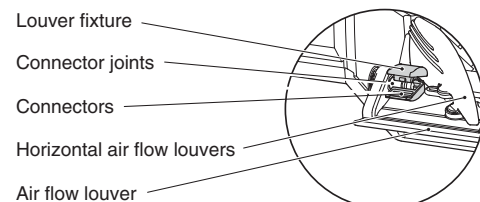
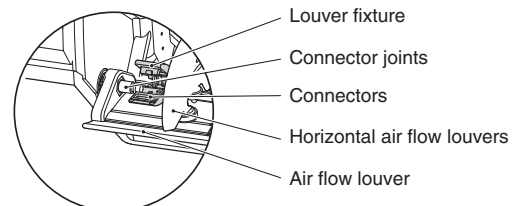

Fig. 10-6-12

- 3) After pushing in the connector joints, align the positions of the connector joints and connectors.
- 4) Push the louver fixture downwards to lock it into place.
- 5) After attaching, move the louver fixture from side to side to check that the connector joint does not come off.



## 11. HOW TO DIAGNOSE THE TROUBLE

The pulse modulating circuits are mounted to both indoor and outdoor units.

Therefore, diagnose troubles according to the trouble diagnosis procedure as described below.

(Refer to the check points in servicing written on the wiring diagrams attached to the indoor/outdoor units.)

**Table 11-1**

No.	Troubleshooting Procedure	Page
1	First Confirmation	94
2	Primary Judgment	95
3	Judgment by Flashing LED of Indoor Unit	95
4	Self-Diagnosis by Remote Controller (Check Code)	96
5	Judgment of Trouble by Symptom	99
6	Trouble Diagnosis by Outdoor LED	105
7	Troubleshooting	113
8	Inspection of the Main Parts	114
9	How to Simply Judge Whether Outdoor Fan Motor is Good or Bad	118

### NOTE

A large-capacity electrolytic capacitor is used in the outdoor unit controller (inverter). Therefore, if the power supply is turned off, charge (charging voltage DC280V to 373V) remains and discharging takes a lot of time (for more than 5 minutes). After turning off the power source, if touching the charging section before discharging, an electrical shock may be caused.

Discharge the electrolytic capacitor completely by using solder iron, etc.

### WARNING

The electrolytic capacitor may not normally discharge according to error contents and the voltage may remain.

Therefore, be sure to discharge the capacitor.

### WARNING

For discharging, never use a screwdriver and others for short-circuiting between + and – electrodes,

As the electrolytic capacitor is one with a large capacity, it is very dangerous because a large electric spark will occur.

### <Discharging method>

Connect the discharge resistance (approx. 100Ω/40W) or plug of the soldering iron to voltage between + and – of C13 on the main P.C. board MCC-1571, and then perform discharging.

Discharge position + and - of C13  
(Discharging period: 10 seconds or more)

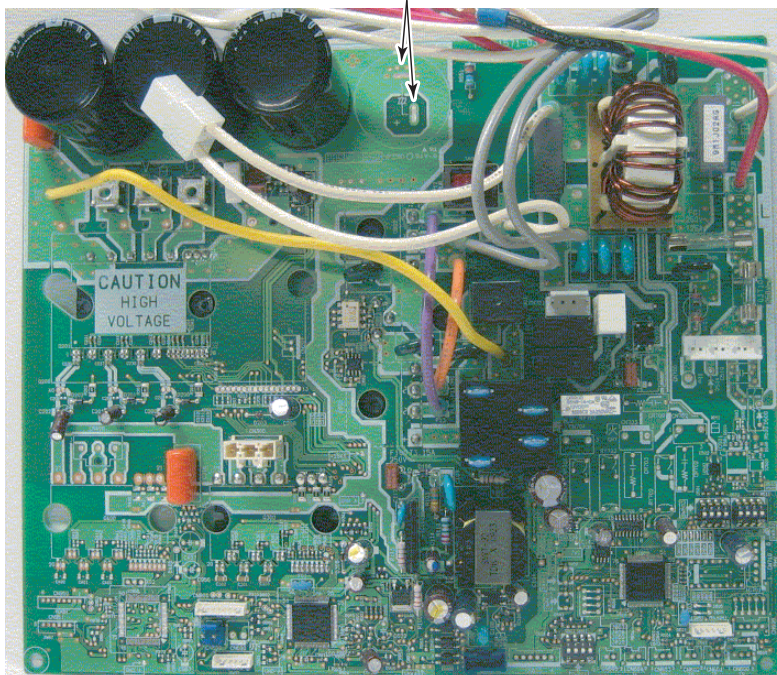

**Fig. 11-1**

## 11-1. First Confirmation

### 11-1-1. Confirmation of Power Supply

Confirm that the power breaker operates (ON) normally.

### 11-1-2. Confirmation of Power Voltage

Confirm that power voltage is AC 220–240 ±10%.

If power voltage is not in this range, the unit may not operate normally.

### 11-1-3. Operation Which is not a Trouble (Program Operation)

For controlling the air conditioner, the program operations are built in the microcomputer as described in the following table.

If a claim is made for running operation, check whether or not it meets to the contents in the following table.

When it does, we inform you that it is not trouble of equipment, but it is indispensable for controlling and maintaining of air conditioner.

Table 11-1-1

No.	Operation of air conditioner	Description
1	When power breaker is turned "ON", the operation lamp (Green) of the indoor unit flashes.	The OPERATION lamp of the indoor unit flashes when power source is turned on. If "START/STOP" button is operated once, flashing stops. (Flashes also in power failure)
2	Compressor may not operate even if the room temperature is within range of compressor-ON.	The compressor does not operate while compressor restart delay timer (3-minutes timer) operates. The same phenomenon is found after power source has been turned on because 3-minutes timer operates.
3	In DRY and SLEEP MODE, FAN (air flow) display does not change even though FAN (air flow select) button is operated.	The air flow indication is fixed to [AUTO].
4	Increasing of compressor motor speed stops approx. 30 seconds after operation started, and then compressor motor speed increases again approx. 30 seconds after.	For smooth operation of the compressor, the compressor motor speed is restricted to Max. 33 rps for 2 minutes and Max. 57 rps for 2 minutes to 4 minutes, respectively after the operation has started.
5	The set value of the remote control should be below the room temperature.	If the set value is above the room temperature, Cooling operation is not performed. And check whether battery of the remote control is consumed or not.
6	In AUTO mode, the operation mode is changed.	After selecting Cool or Heat mode, select an operation mode again if the compressor keeps stop status for 15 minutes.
7	In HEAT mode, the compressor motor speed does not increase up to the maximum speed or decreases before the temperature arrives at the set temperature.	The compressor motor speed may decrease by high-temp. release control (Release protective operation by temp.-up of the indoor heat exchanger) or current release control.
8	Cool, Dry, or Heat operation cannot be performed.	When the unit in other room operates previously in different mode, Fan Only operation is performed because of first-push priority control. (Cool operation and Dry operation can be concurrently performed.)

## 11-2. Primary Judgment

To diagnose the troubles, use the following methods.

- 1) Judgment by flashing LED of indoor unit
- 2) Self-diagnosis by service check remote controller
- 3) Judgment of trouble by every symptom

Firstly use the method (1) for diagnosis. Then, use the method (2) or (3) to diagnose the details of troubles.

For any trouble occurred at the outdoor unit side, detailed diagnosis is possible by 6-serial LED on the control P.C. board.

## 11-3. Judgment by Flashing LED of Indoor Unit

While the indoor unit monitors the operation status of the air conditioner, if the protective circuit operates, the contents of self-diagnosis are displayed with block on the indoor unit indication section.

Table 11-3-1

	Item	Check code	Block display	Description for self-diagnosis
<div style="border: 1px solid black; padding: 5px; width: fit-content;">Indoor indication lamp flashes.</div> <p style="text-align: center;">↓</p> <div style="border: 1px solid black; padding: 5px; width: fit-content;">Which lamp does flash?</div> <p style="text-align: center;">↓</p> <p style="text-align: center;">→</p>	<b>A</b>	—	OPERATION (Green) Flashing display (1 Hz)	Power failure (when power is ON)
	<b>B</b>	00	OPERATION (Green) Flashing display (5 Hz)	Protective circuit operation for indoor P.C. board
	<b>C</b>	01	OPERATION (Green) TIMER (Orange) Flashing display (5 Hz)	Protective circuit operation for connecting cable and serial signal system
	<b>D</b>	02	OPERATION (Green) Flashing display (5 Hz)	Protective circuit operation for outdoor P.C. board
	<b>E</b>	03	OPERATION (Green) TIMER (Orange) Flashing display (5 Hz)	Protective circuit operation for others (including compressor)

### NOTE

- The contents of items B and C and a part of item E are displayed when air conditioner operates.
- When item B and C, and item B and a part of item E occur concurrently, priority is given to the block of item B.
- The check codes can be confirmed on the remote controller for servicing.

## 11-4. Self-Diagnosis by Remote Controller (Check Code)

1. If the lamps are indicated as shown B to E in Table 11-3-1, execute the self-diagnosis by the remote controller.
2. When the remote controller is set to the service mode, the indoor controller diagnoses the operation condition and indicates the information of the self-diagnosis on the display of the remote controller with the check codes.

If a fault is detected, all lamps on the indoor unit will flash at 5Hz and it will beep for 10 seconds (beep, beep, beep ...). The timer lamp usually flashes (5Hz) during self-diagnosis.

### 11-4-1. How to Use Remote Controller in Service Mode

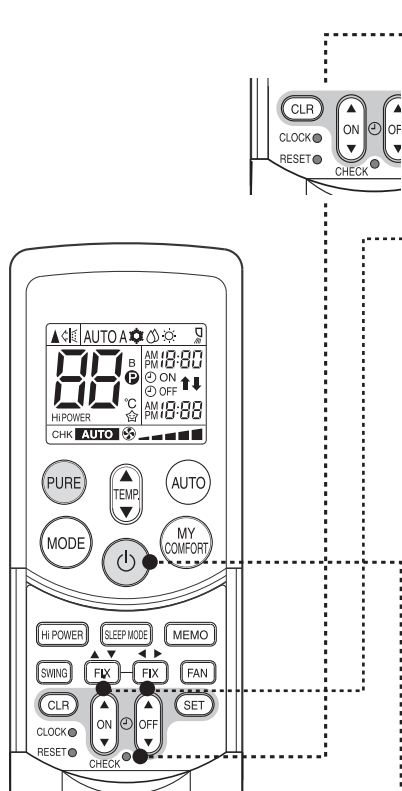

**1** Push [CHECK] button with a tip of pencil to set the remote controller to the service mode.

- “00” is indicated on the display of the remote controller.

**2** Push [ON ▲] or [OFF ▼] button

If there is no fault with a code, the indoor unit will beep once (Beep) and the display of the remote controller will change as follows :

00 → 01 → 02 ... 1d → 1E → 33

- The TIMER indicator of the indoor unit flashes continuously. (5 times per 1 sec.)
- Check the unit with all 52 check codes ( 00 to 33 ) as shown in Table-11-4-1.
- Press [ON ▲] or [OFF ▼] button to change the check code backward.

If there is a fault, the indoor unit will beep for 10 seconds (Beep, Beep, Beep ...).

Note the check code on the display of the remote controller.

- 2-digits alphanumeric will be indicated on the display.
- All indicators on the indoor unit will flash. (5 times per 1 sec.)

**3** Push [START/STOP] button to release the service mode.

- The display of the remote controller returns to as it was before service mode was engaged.

**4** Time shortening method.

1. Push SET button while pushing CHECK button.
2. Push [START/STOP] button.

Alphanumeric characters are used for the check codes.

5 is 5.	6 is 6.
A is A.	b is B.
C is C.	d is D.

Fig. 11-4-1

### 11-4-2. Check Code

1. After servicing, push the START/STOP button to return to the normal mode.
2. After servicing by the check code, turn off breaker of the power supply, and turn on breaker of the power supply again so that memory in the microcomputer returns the initial status.  
However, the check codes are not deleted even if the power supply is turned off because they are stored in the fixed memory.
3. After servicing, push [CLR] button under check mode status and then send the check code "7F" to the indoor unit. The error code stored in memory is cleared.

Table 11-4-1

Block distinction		Operation of diagnosis function				Judgment and action
Check code	Block	Check code	Cause of operation	Air conditioner status	Remarks	
00	Indoor P.C. board etc.	01	Short-circuit or disconnection of the room temperature sensor (TA sensor).	Operation continues.	Displayed when error is detected.	1. Check the room temp. sensor. 2. When the room temp. sensor is normal, check P.C. board.
		02	Being out of place, disconnection, short-circuit, or migration of heat exchanger sensor (TC sensor)	Operation continues.	Displayed when error is detected.	1. Check heat exchanger sensor. 2. When heat exchanger sensor is normal, check P.C. board.
		0F	Being out of place, disconnection, short-circuit, or migration of heat exchanger sensor (TCj sensor)	Operation continues.	Displayed when error is detected.	1. Check heat exchanger sensor. 2. When heat exchanger sensor is normal, check P.C. board.
		11	Lock of indoor fan or trouble on the indoor fan circuit	All off	Displayed when error is detected.	1. Check the motor. 2. When the motor is normal, check P.C. board.
	Not displayed	12	Trouble on other indoor P.C. boards	Operation continues.	Displayed when error is detected.	Replace P.C. board.
01	Connecting cable and serial signal	04	Return serial signal is not sent to indoor side from operation started. 1) Defective wiring of connecting cable 2) Operation of compressor thermo Gas shortage Gas leak	Operation continues.	Flashes when trouble is detected on Return serial signal, and normal status when signal is reset.	1. When the outdoor unit never operate: 1) Check connecting cable, and correct if defective wiring. 2) Check 25A fuse of inverter P.C. board. 3) Check 6.3A fuse of connecting cable of inverter unit and outdoor unit. 2. To display [Other] block during operation, check compressor thermo. operation and supply gas (check gas leak also). 3. Unit operates normally during check.  If return serial signal does not stop between indoor terminal board 2 and 3, replace inverter P.C. board.  If signal stops between indoor terminal board 2 and 3, replace indoor P.C. board.



Block distinction		Operation of diagnosis function				Judgment and action
Check code	Block	Check code	Cause of operation	Air conditioner status	Remarks	
02	Outdoor P.C. board	14	Inverter over-current protective circuit operates. (Short time)	All off	Displayed when error is detected.	Even if trying operation again, all operations stop immediately. : Replace P.C. board.
		15	Position-detect circuit error or short-circuit between windings of compressor	All off	Displayed when error is detected.	1. Even if connecting lead wire of compressor is removed, position-detect circuit error occurred. : Replace P.C. board. 2. Measure resistance between wires of compressor, and perform short-circuit. : Replace compressor.
		17	Current-detect circuit error	All off	Displayed when error is detected.	Even if trying operation again, all operations stop immediately. : Replace P.C. board.
		18	Being out of place, disconnection or short-circuit of the outdoor heat exchanger sensor (TE) or suction temp. sensor (TS)	All off	Displayed when error is detected.	1. Check sensors (TE, TS). 2. Check P.C. board.
		19	Disconnection or short-circuit of discharge temp. sensor	All off	Displayed when error is detected.	1. Check discharge temp. sensor (TD). 2. Check P.C. board
		1A	Outdoor fan drive system error	All off	Displayed when error is detected.	Position-detect error, over-current protective operation of outdoor fan drive system, fan lock, etc. : Replace P.C. board or fan motor.
	Not displayed	1b	Being out of place, disconnection or short-circuit of the outdoor temp. sensor (TO)	Operation continues	—	1. Check outdoor temp. sensor (TO). 2. Check P.C. board.
	Outdoor P.C. board	1c	Compressor drive output error, Compressor error (lock, missing, etc.), Break down • Disconnection or short-circuit of the gas side sensor (TG). • Communication error between MCUs on outdoor P.C. board.	All off	Displayed when error is detected.	Check 6-serial LED. When 20 seconds passed after start-up, position-detect circuit error occurred. : Replace compressor. Trouble on P.M.V. • Check gas side temp. sensor (TG). • Check P.C. board. • Check communication wire between outdoor P.C. board. • Check outdoor P.C. board.
03	Others (including compressor)	07	Return serial signal has been sent when operation started, but it is not sent from halfway. 1) Compressor thermo. operation Gas shortage Gas leak 2) Instantaneous power failure	Operation continues	Flashes when trouble is detected on return serial signal, and normal status when signal is reset.	1. Repeat Start and Stop with interval of approx. 10 to 40 minutes. (Code is not displayed during operation.) Supply gas. (Check also gas leak). 2. Unit operates normally during check. If return serial signal does not stop between indoor terminal block 2 and 3, replace inverter P.C. board. If signal stops between indoor terminal block 2 and 3, replace indoor P.C. board.
		1d	Compressor does not rotate. (Current protective circuit does not operate when a specified time passed after compressor had been activated.)	All off	Displayed when error is detected.	1. Trouble on compressor 2. Trouble on wiring of compressor (Missed phase)
		1E	Discharge temp. exceeded 117°C	All off	Displayed when error is detected.	1. Check discharge temp. sensor (TD). 2. Gas leakage 3. Trouble on PMV.
		1F	Break down of compressor	All off	Displayed when error is detected.	1. Check power voltage. (220–230–240 V +10%) 2. Overload operation of refrigeration cycle Check installation condition (Short-circuit of outdoor diffuser).
		08	4-way valve inverse error (TC sensor value lowered during heating operation.)	Operation continues	—	1. Check 4-way valve operation.
		20	P.M.V. error	All off	Displayed when error is detected.	1. Check LED (D800–D805) on inverter P.C. board. 2. Check connection of P.M.V. wiring. 3. Start operation. (Excluding error room) 4. If the same error is occurred. Replace P.M.V.

## 11-5. Judgment of Trouble by Symptom

### 11-5-1. Indoor Unit (Including Remote Controller)

#### (1) Power of indoor unit does not turned on

##### <Primary check>

1. Is the supply voltage normal?
2. Is the normal voltage provided to the outdoor unit?
3. Is the crossover cable connected properly?
4. Is the fuse (F01) blown?

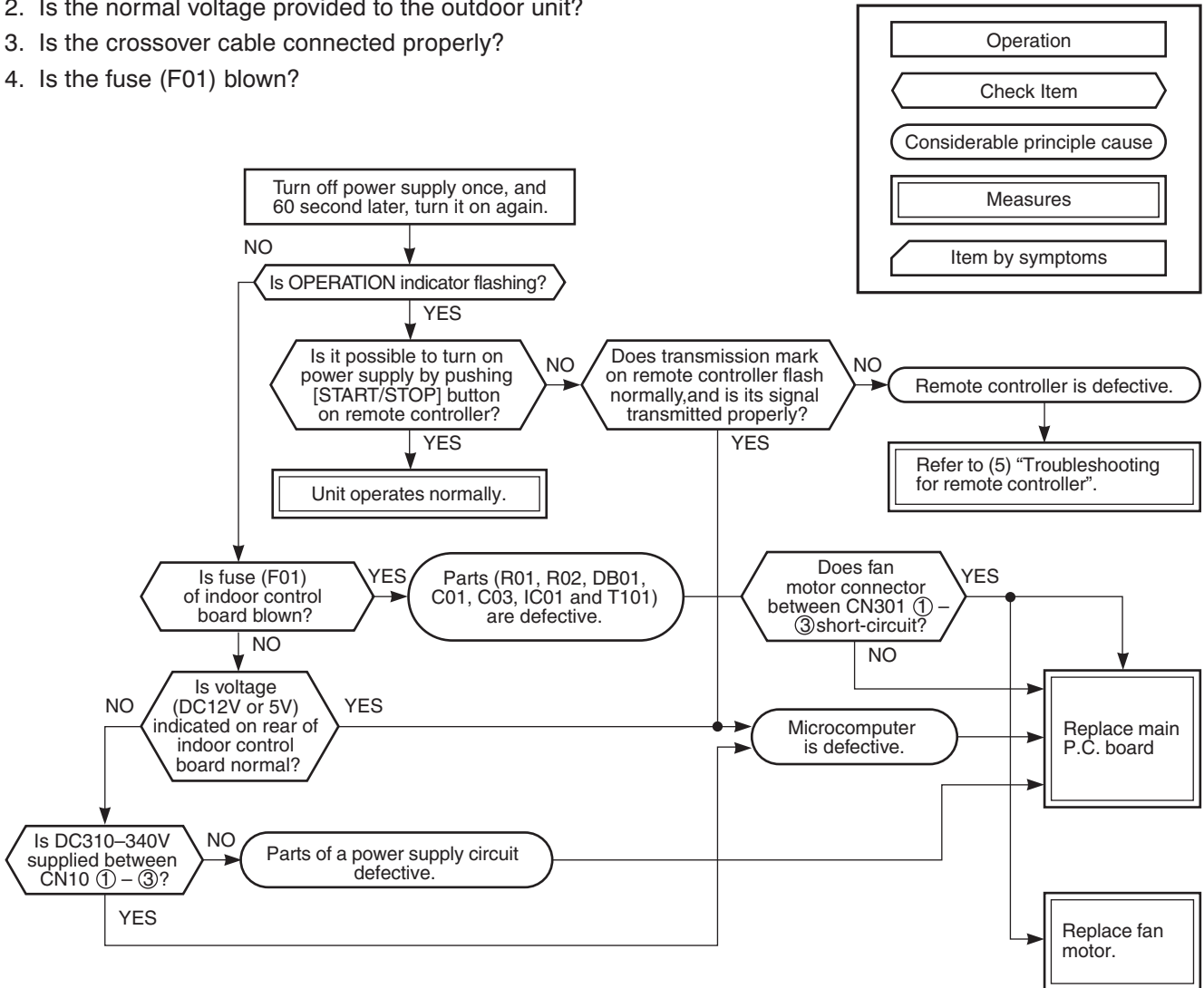

- Be sure to disconnect the motor connector CN301 after shut off the power supply, or it will be a cause of damage of the motor.

#### (2) Power of indoor unit does not turned on though Indoor P.C. board is replaced

##### <Confirmation procedure>

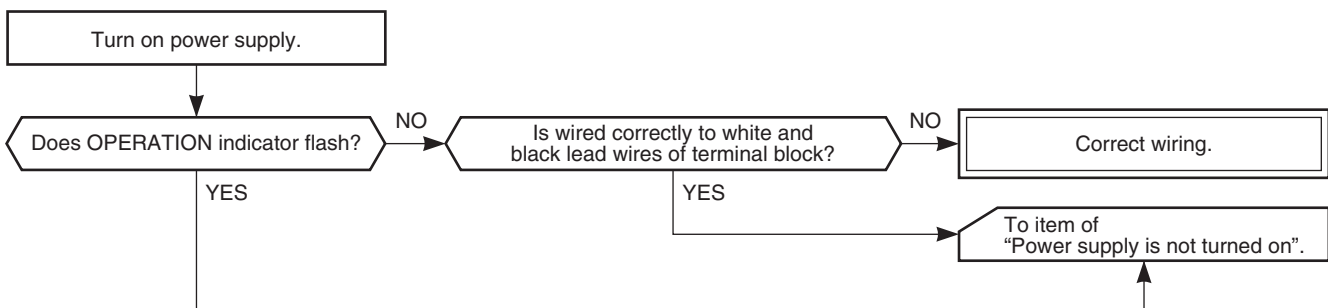



### (3) Only the indoor motor fan does not operate

#### <Primary check>

1. Is it possible to detect the power supply voltage (AC220–240V) between ① and ② on the terminal block?
2. Does the indoor fan motor operate in cooling operation?  
(In heating operation, the indoor fan motor does not operate for approximately 10 minutes after it is turned on, to prevent a cold air from blowing in.)

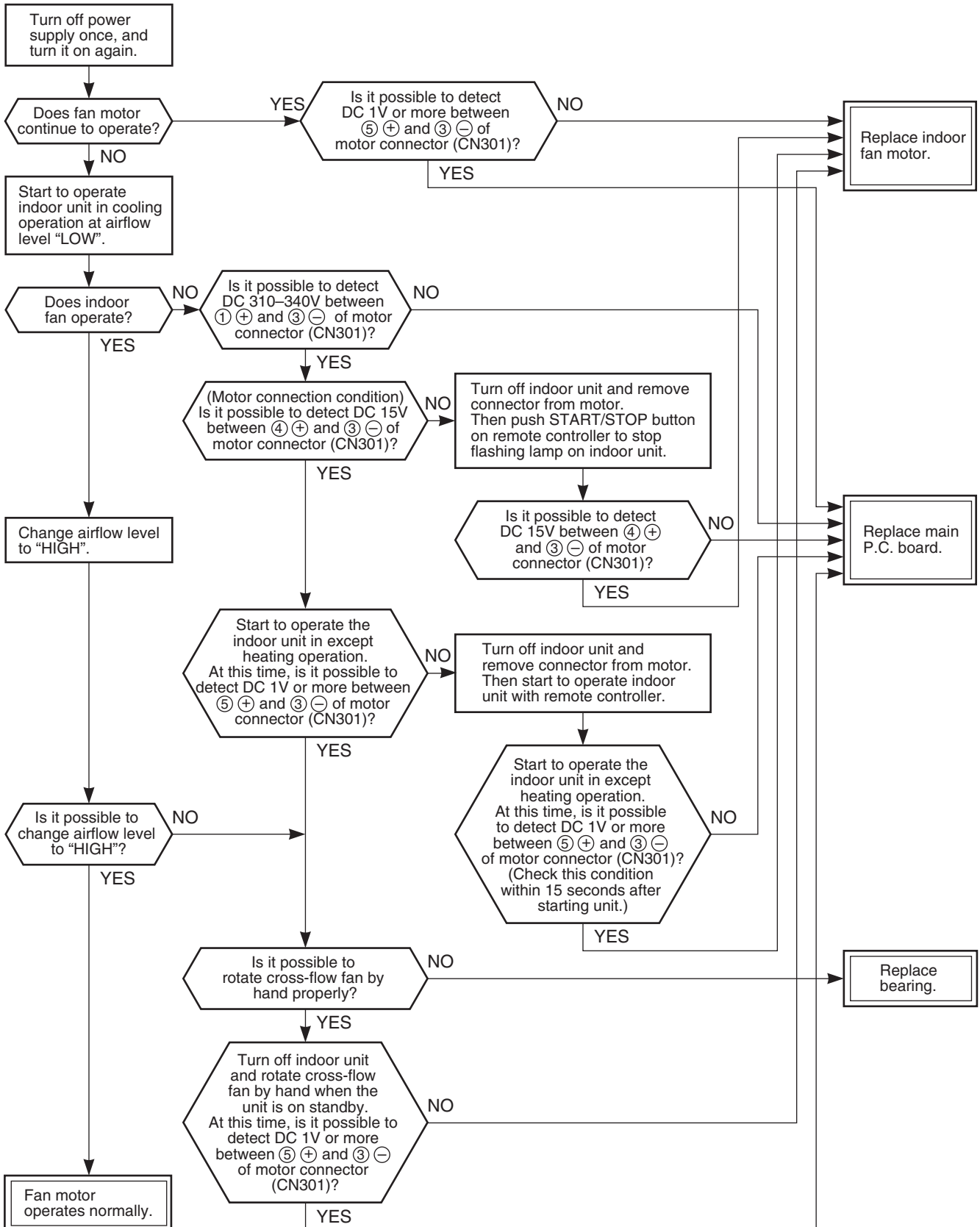

#### (4) Indoor fan motor automatically starts to rotate by turning on power supply

##### <Cause>

The IC is built in the indoor fan motor. Therefore the P.C. board is also mounted to inside of the motor.

If the P.C. board is soldered imperfectly or the IC is defective, the fan motor may automatically rotate by turning on power supply.

##### <Inspection procedure>

1. Remove the front panel. (Remove 2 screws.)
2. Remove the cover of the fan motor lead wires.
3. Check DC voltage with CN301 connector while the fan motor is rotating.

##### NOTE

- Do not disconnect the connector while the fan motor is rotating.
- Use a thin test rod.

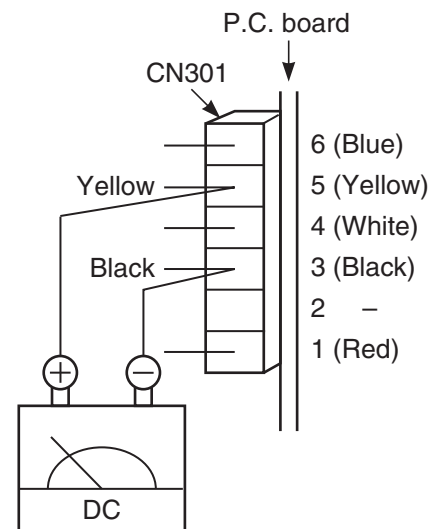
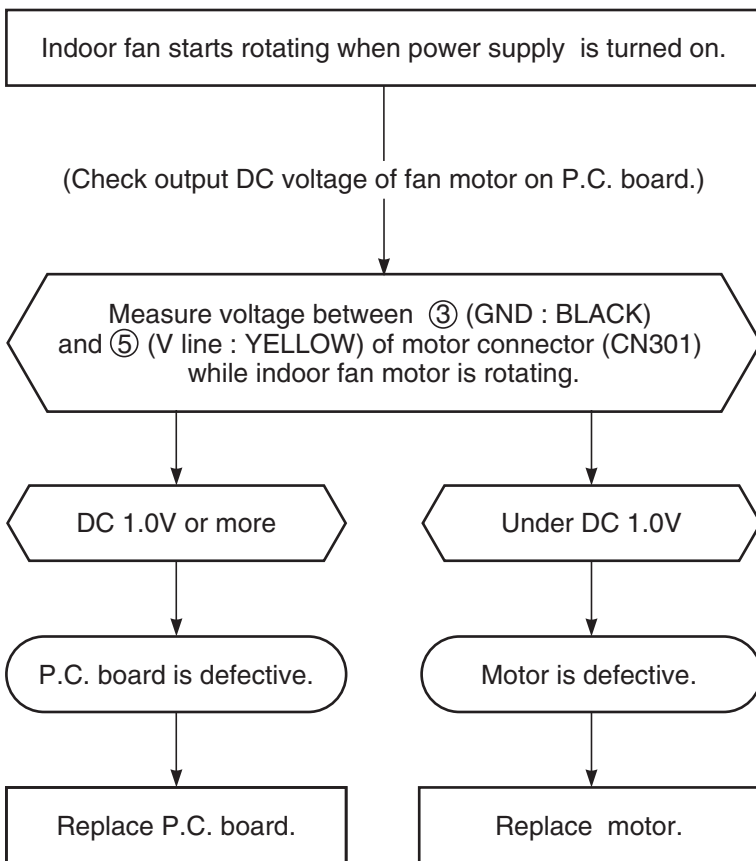

## (5) Troubleshooting for remote controller

### <Primary check>

Check that A or B selected on the main unit is matched with A or B selected on the remote controller.

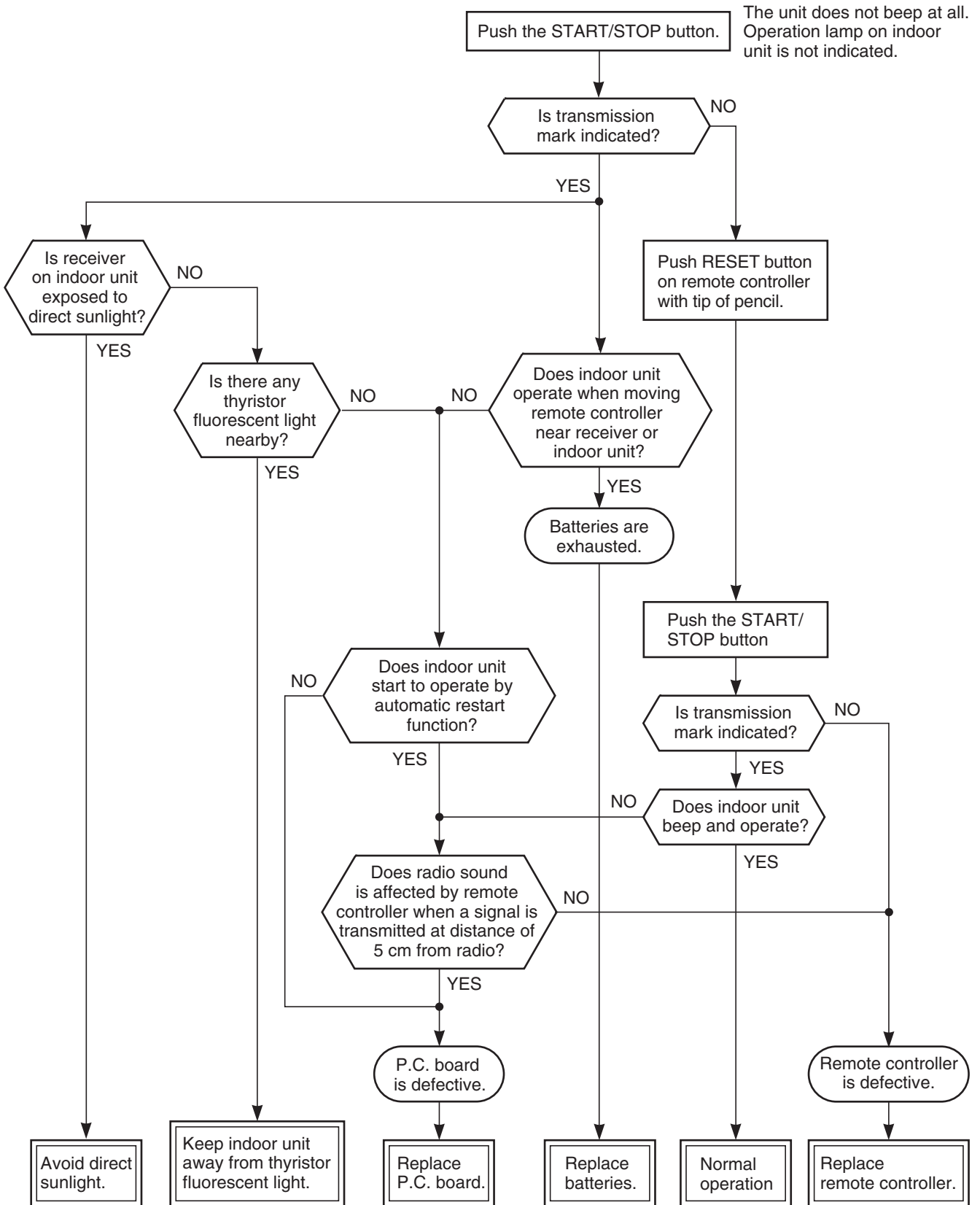

**NOTE :** After replacing batteries, push the RESET button with a tip of a pencil.

## 11-5-2. Wiring Failure (Interconnecting and Serial Signal Wire)

### (1) Outdoor unit does not operate

- 1) Is the voltage between ② and ③ of the indoor terminal block varied?
- 2) Confirm that transmission from indoor unit to outdoor unit is correctly performed based upon the following diagram.

#### NOTE

- Measurement should be performed 2 minutes and 30 seconds after starting of the operation.
- Be sure to prepare a diode for judgment.

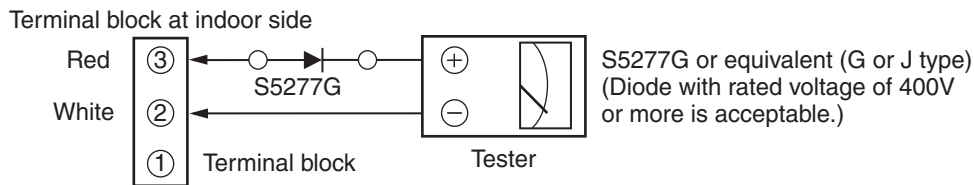

Normal time : Voltage swings between DC15 and 60V. ....Inverter Assembly check

Abnormal time : Voltage does not vary.

### (2) Outdoor unit stops in a little while after operation started

<Check procedure> Select phenomena described below.

- 1) The outdoor unit stops 10 to 20 minutes after operation started, and 10 minutes or more are required to restart the unit.

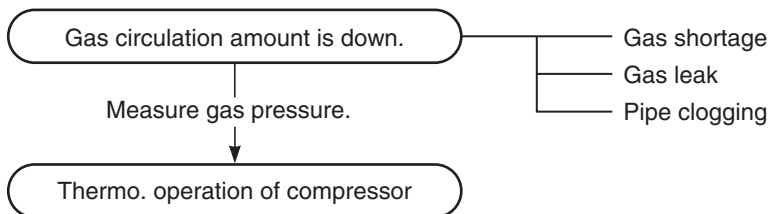

- 2) If the unit stops once, it does not operate until the power will be turned on again.

To item of Outdoor unit does not operate.

- 3) The outdoor unit stops 10 minutes to 1 hour after operation started, and an alarm is displayed. (Discharge temp. error check code 03, 1E Sensor temp. error check code 02, 1C)

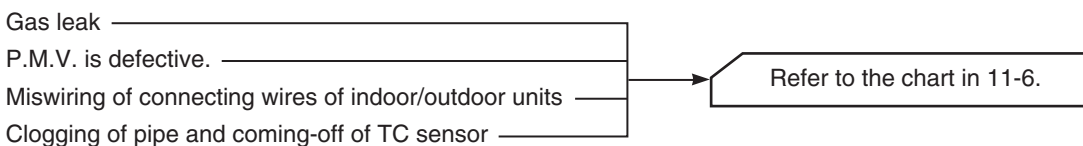

# Service Support Function (LED Display, Switch Operation)

## 1. Outline

A various setup and operation check can be performed by DIP switches at 2 positions (SW801, SW802) and the pushdown button switches (SW800) on the outdoor control P.C. board MCC-5071.

### Operation part

Part No.	Specifications	Operation contents
SW800	Pushdown button switch	Performs the specific operation to check maintenance and various initial settings.
SW801	DIP switch	
SW802	DIP switch	

### Display part

Part No.	Specifications	Operation contents
D502, D511, D517, D524, D531	Orange LED	Indoor/Outdoor communication (Serial communication) signal display (Receive signal from indoor signal)
D501, D508, D515, D520, D527	Green LED	Indoor/Outdoor communication (Serial communication) signal display (Send signal from outdoor signal)
D800	Green LED	(1) Power-ON display When the power of the outdoor unit is turned on, D800 LED goes on.
D801 to D805	Red LED	(2) Error display When the outdoor controller detects some errors, some LEDs go on or flash according to the error as described in Error display table. (Refer to 11-6)
		(3) Specific operation display When SW800 is pushed and a specific operation is operated, some LEDs go on or flash.

\* Every LED is colorless when it goes off.

### Control P.C.B MCC-5071

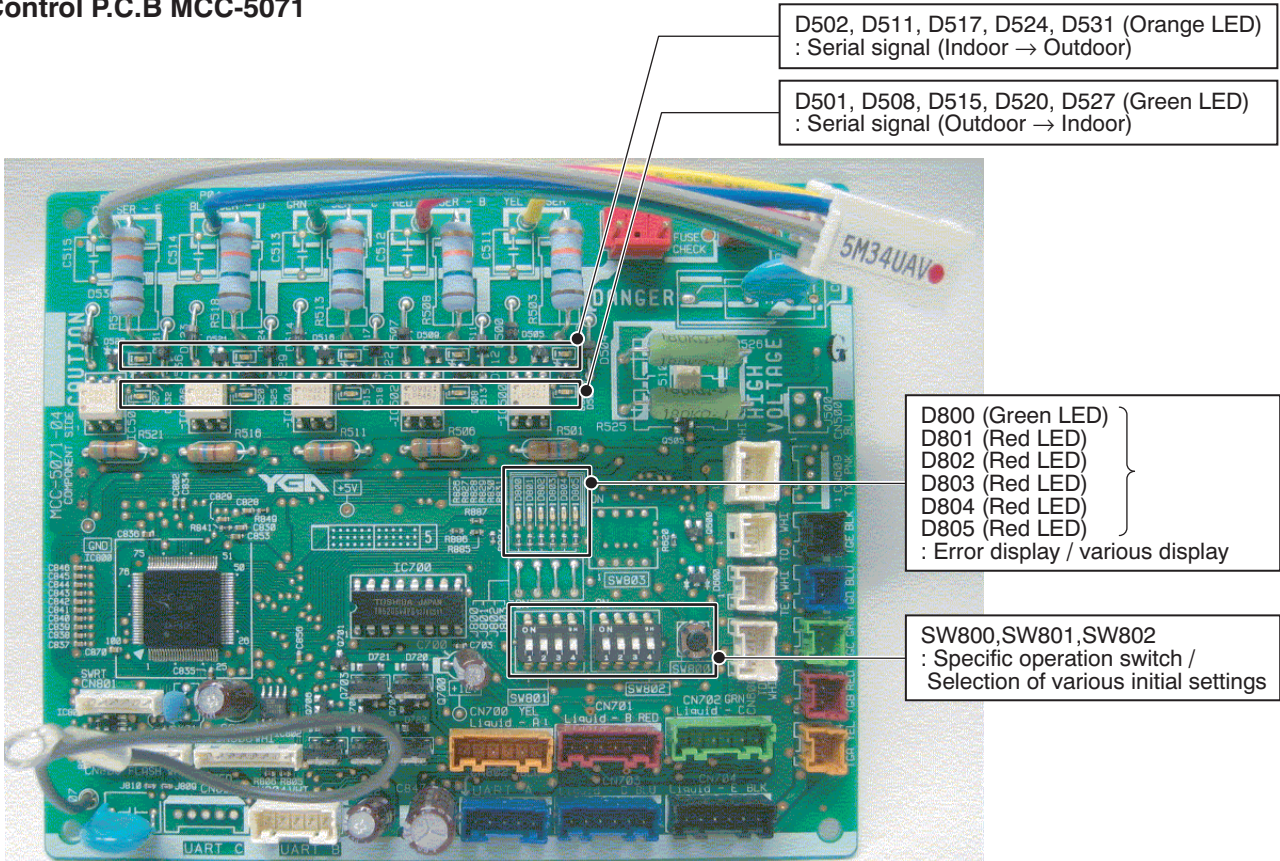

## 11-6. Trouble Diagnosis by Outdoor LED

For the outdoor unit, the self-diagnosis is possible by LED (Green) and five LEDs (Red).

\* LED (Green)(D800) and LEDs (Red)(D801 to D805) are provided on the control P.C. board MCC-5071.

1. If there is an error, LED (Red or Green) goes on or flashes according to the error as described in the below table.
2. When there are two or more errors, LEDs go on cyclically.
3. Usually, LED (Green)(D800) goes on.

### (Legend)

- ◎ D800 (Green)
- D801 (Red)
- D802 (Red)                      ● : Go off, ○ : Go on, ◎ : Flash
- D803 (Red)
- D804 (Red)
- D805 (Red)

PMV : Pulse Motor Valve

LED display						Indoor check code	Description
D800	D801	D802	D803	D804	D805		
○	●	●	●	●	●	—	During normal operation
●	○	●	●	●	●	07	Case thermo. operation, Power supply error
●	●	○	●	●	●	14	Driving element short-circuit
●	○	○	●	●	●	16	Position detection circuit error
●	●	●	○	●	●	17	Current detection circuit error
●	○	●	○	●	●	1C	Compressor system error, Compressor lock
●	●	○	○	●	●	19	Discharge temp. sensor (TD) error
●	○	○	○	●	●	1A	Fan system error
*1	●	●	●	○	●	1B	Outside temp. sensor (TO) error
	●	○	●	●	○	1D	Compressor lock
	●	●	○	●	○	1E	Discharge temp. error, gas leakage
	●	○	○	●	○	1F	Compressor break down
	●	●	●	○	○	18	Suction temp. sensor (TS) error
	●	○	●	○	○	18	Heat exchanger temp. sensor (TE) error
*2	●	○	○	○	○	1C	A room gas side temp. sensor (TGa) error
*2	●	○	●	●	○	1C	B room gas side temp. sensor (TGb) error
*2	●	○	○	●	○	1C	C room gas side temp. sensor (TGc) error
*2	●	●	●	●	○	1C	D room gas side temp. sensor (TGd) error
*2	●	●	●	○	○	1C	E room gas side temp. sensor (TGe) error
	●	○	○	○	○	1C	Gas leak detection, PMV error
	●	○	○	○	○	1C	Communication error between MCU
	●	○	○	○	○	1C	Communication error between MCU
	●	●	○	○	○	1C	Communication error between MCU
	◎	○	●	●	●	20	PMV error for A room
	◎	●	○	●	●	20	PMV error for B room
	◎	●	●	○	●	20	PMV error for C room
	◎	●	●	●	○	20	PMV error for D room
	◎	●	●	●	○	20	PMV error for E room

\*1: Back-up operation is performed without error display of the indoor unit.

\*2: Operated normally when the air conditioners in other rooms are driven.



Check code	Outdoor LED display	Check and troubleshooting (Item without special mention indicates part of outdoor unit.)
[07]	●○●●●●	<p><b>[Case thermo operation, Power supply error ]</b></p> <pre> graph TD     Q1{{Is AC mains voltage correct? (198 to 264V)}} -- NO --&gt; A1[Confirm power supply construction. etc.]     Q1 -- YES --&gt; Q2{{Are CN609 of P.C. board MCC-1571 connection and case thermostat correct?}}     Q2 -- NO --&gt; A2[Correct connector. Case thermostat error → Replace.]     Q2 -- YES --&gt; Q3{{Short each pins of CN609. Can compressor operate?}}     Q3 -- NO --&gt; A3[Check outdoor P.C.B MCC-1571. Defect → Replace.]     Q3 -- YES --&gt; Q4{{Is there gas leak? Is there refrigerant shortage?}}     Q4 -- YES --&gt; A4[Repair defective position. Recharge refrigerant.]     Q4 -- NO --&gt; Q5{{Is service valve fully opened?}}     Q5 -- NO --&gt; A5[Open service valve fully.]     Q5 -- YES --&gt; Q6{{Is PMV under correct conditions?}}     Q6 -- NO --&gt; A6[Correct defective position. Replace defective part.]     Q6 -- YES --&gt; A7[Check crushed or broken pipe. Defect → Correct and Replace.] </pre>
[14]	●●○●●●	<p><b>[Short-circuit of compressor drive element]</b></p> <pre> graph TD     Q1{{Are connections of compressor lead and reactor correct? (Check referring to the Wiring diagram.)}} -- NO --&gt; A1[Correct wiring.]     Q1 -- YES --&gt; Q2{{Does the same error occur in operation without compressor lead?}}     Q2 -- YES --&gt; A2[Replace outdoor P.C.B MCC-1571.]     Q2 -- NO --&gt; A3[Check compressor. (Rare short, etc.) Defect → Replace.] </pre>
[16]	●○○●●●	<p><b>[Position detection circuit error]</b></p> <div data-bbox="507 1682 965 1771" style="border: 1px solid black; padding: 5px; width: fit-content; margin: 0 auto;"> <p>Check outdoor P.C.B MCC-1571. Defect → Replace.</p> </div>
[17]	●●●○●●	<p><b>[Current detection circuit error]</b></p> <div data-bbox="507 1917 965 2007" style="border: 1px solid black; padding: 5px; width: fit-content; margin: 0 auto;"> <p>Check outdoor P.C.B MCC-1571. Defect → Replace.</p> </div>



Check code	Outdoor LED display	Check and troubleshooting (Item without special mention indicates part of outdoor unit.)
[18]	<p>●●●○○●</p> <p>●○○○○●</p>	<p>* There is a possibility that it is one of the following errors. Confirm LED on outdoor P.C. board to judge which error it is. Heat exchanger temp. sensor (TE) error, Suction temp. sensor (TS) error</p> <p><b>[Suction temp. sensor (TS) error]</b></p> <p><b>[Heat exchanger temp. sensor (TE) error]</b></p>
[19]	●●○○●●	<p><b>[Discharge temp. sensor (TD) error]</b></p>
[1A]	●○○○●●	<p><b>[Fan system error]</b></p>
[1B]	●●●●○○	<p><b>[Outside temp. sensor (TO) error]</b></p>

Check code	Outdoor LED display	Check and troubleshooting (Item without special mention indicates part of outdoor unit.)
[1C]	●○●○●●	<p>* There is a possibility that it is one of the following errors. Confirm LED on outdoor P.C. board to judge which error it is. Compressor system error, Compressor lock, Gas side temp. sensor (TGa to TGe) error, Gas leakage, PMV error</p> <p><b>[Compressor system error, Compressor lock]</b></p> <pre> graph TD     Q1{{Is AC mains voltage correct? (198 to 264V)}} -- NO --&gt; A1[Check wiring construction. Ask repair of power supply.]     Q1 -- YES --&gt; Q2{{Is wire connection correct? Compressor lead (Board side, Compressor Side), Reactor lead, Power supply lead.}}     Q2 -- NO --&gt; A2[Check wire connection and correct it.]     Q2 -- YES --&gt; Q3{{Is compressor under correct condition?}}     Q3 -- YES --&gt; C1((1))     Q3 -- NO --&gt; Q4{{Is there refrigerant stagnation?}}     Q4 -- NO --&gt; A3[Compressor lock → Replace.]     Q4 -- YES --&gt; Q5{{Does PMV correctly operate?}}     Q5 -- NO --&gt; A4[Check TE, TS sensor and PMV. Detect → Replace..]     Q5 -- YES --&gt; C2((1))     C1 --&gt; C2     C2 --&gt; Q6{{Are the power devices on P.C. board MCC-1571 screwed without looseness? (Rear sides of Q201, Q300, Q650, DB01, DB02) Are radiation grease properly applied? (Q201)}}     Q6 -- NO --&gt; A5[Apply radiation grease to objective parts. Retightening of screws. (Be sure not to forget to attach insulating sheet between heat sink and Q300, Q650, DB01, DB02)]     Q6 -- YES --&gt; Q7{{Does something block the ventilation around the heat sink? Does something air flow from the fan?}}     Q7 -- YES --&gt; A6[Remove blocking matter. Correct short-circuit.]     Q7 -- NO --&gt; A7[Check outdoor P.C.B MCC-1571 and MCC-5071. Defect → Replace] </pre>

Check code	Outdoor LED display	Check and troubleshooting (Item without special mention indicates part of outdoor unit.)
[1C] (Continued)	●○○○○●	<p><b>[A room gas side temp. sensor (TGa) error]</b></p>
	●○○●●○○	<p><b>[B room gas side temp. sensor (TGb) error]</b></p>
	●○○●●○○	<p><b>[C room gas side temp. sensor (TGc) error]</b></p>
	●●●●●○○	<p><b>[D room gas side temp. sensor (TGd) error]</b></p>
	●●●○○●○	<p><b>[E room gas side temp. sensor (TGe) error]</b></p>
	●○○○○●○	<p><b>[Gas leak detection, PMV error]</b></p>

Check code	Outdoor LED display	Check and troubleshooting (Item without special mention indicates part of outdoor unit.)
[1C] (Continued)		<p><b>[Communication error between MCUs]</b></p> <p>Are connections of CN802 on P.C.B MCC-5071 and CN802 on P.C.B MCC-1571 correct?</p> <p>NO → Correct connection.</p> <p>YES → Check outdoor P.C. Boards. Defect → Replace.</p> <hr/> <p><b>[Communication error between MCUs]</b></p> <p>Are connections of CN804 on P.C.B MCC-5071 and CN800 on P.C.B MCC-1571 correct?</p> <p>NO → Correct connection.</p> <p>YES → Check outdoor P.C. Boards. Defect → Replace.</p>
[1D]		<p><b>[Compressor lock]</b></p> <p>Is AC mains voltage correct? (198 to 264V)</p> <p>NO → Check wiring construction. Ask repair of power supply.</p> <p>YES →</p> <p>Is wire connection correct? Compressor lead (Board side, Compressor Side), Reactor lead, Power supply lead.</p> <p>NO → Check wire connection and correct it.</p> <p>YES →</p> <p>Is compressor under correct condition?</p> <p>YES → Check outdoor P.C.B MCC-1571. Defect → Replace.</p> <p>NO →</p> <p>Is there refrigerant stagnation?</p> <p>NO → Compressor lock → Replace.</p> <p>YES →</p> <p>Does PMV correctly operate?</p> <p>NO → Check TE, TS sensors and PMV. Detect → Replace.</p> <p>YES → Check outdoor P.C.B MCC-5071. Defect → Replace.</p>
[1E]		<p><b>[Discharge temp. error]</b></p> <p>Is there gas leak? Is there refrigerant shortage?</p> <p>YES → Repair defective position. Recharge refrigerant.</p> <p>NO →</p> <p>Is PMV under correct conditions?</p> <p>NO → Repair defective position. Replace defective part.</p> <p>YES →</p> <p>Does an abnormal overload happen?</p> <p>YES → Remove and improve the cause of overload.</p> <p>NO →</p> <p>Is connection of CN600 on P.C.B. MCC-5071? Is resistance value of TD sensor correct?</p> <p>NO → Correct connector. Sensor error → Replace.</p> <p>YES → Check outdoor P.C.B MCC-5071. Defect → Replace.</p>

Check code	Outdoor LED display	Check and troubleshooting (Item without special mention indicates part of outdoor unit.)
[1F]	●○○●○○●	<p><b>[Compressor break down]</b></p> <pre> graph TD     Q1{{Is AC mains voltage correct? (198 to 264V)}} -- NO --&gt; A1[Check wiring construction. Ask repair of power supply.]     Q1 -- YES --&gt; Q2{{Is wire connection correct? Compressor lead (Board side, Compressor Side), Reactor lead, Power supply lead.}}     Q2 -- NO --&gt; A2[Check wire connection and correct it.]     Q2 -- YES --&gt; Q3{{Does an abnormal overload happen?}}     Q3 -- YES --&gt; A3[Remove and improve the cause of overload.]     Q3 -- NO --&gt; A4[Check outdoor P.C.B MCC-1571. Defect -&gt; Replace.] </pre>
[20]	<p>⊙○○●●●●●</p> <p>⊙●○○●●●●</p> <p>⊙●●○○●●●</p>	<p>* There is a possibility that it is one of the following errors. Confirm LED on outdoor P.C. board to judge which error it is. PMV error for A room, B room, C room, D room, E room.</p> <p><b>[PMV error for A room]</b></p> <pre> graph TD     Q1{{Is PMV under correct conditions?}} -- NO --&gt; A1[Repair defective position. Replace defective part.]     Q1 -- YES --&gt; Q2{{Check temp. sensor of A room indoor unit? TA sensor, TC sensor}}     Q2 -- Error --&gt; A2[Correct connector. Sensor error -&gt; Replace.]     Q2 -- OK --&gt; A3[Check outdoor P.C.B MCC-5071 and indoor A room P.C. board. Defect -&gt; Replace.] </pre> <p><b>[PMV error for B room]</b></p> <pre> graph TD     Q1{{Is PMV under correct conditions?}} -- NO --&gt; A1[Repair defective position. Replace defective part.]     Q1 -- YES --&gt; Q2{{Check temp. sensor of B room indoor unit? TA sensor, TC sensor}}     Q2 -- Error --&gt; A2[Correct connector. Sensor error -&gt; Replace.]     Q2 -- OK --&gt; A3[Check outdoor P.C.B MCC-5071 and indoor B room P.C. board. Defect -&gt; Replace.] </pre> <p><b>[PMV error for C room]</b></p> <pre> graph TD     Q1{{Is PMV under correct conditions?}} -- NO --&gt; A1[Repair defective position. Replace defective part.]     Q1 -- YES --&gt; Q2{{Check temp. sensor of C room indoor unit? TA sensor, TC sensor}}     Q2 -- Error --&gt; A2[Correct connector. Sensor error -&gt; Replace.]     Q2 -- OK --&gt; A3[Check outdoor P.C.B MCC-5071 and indoor C room P.C. board. Defect -&gt; Replace.] </pre>

Check code	Outdoor LED display	Check and troubleshooting (Item without special mention indicates part of outdoor unit.)
[20] (Continued)	◎●●●●○●	<p><b>[PMV error for D room]</b></p> <pre> graph TD     Q1{{Is PMV under correct conditions?}} -- NO --&gt; A1[Repair defective position. Replace defective part.]     Q1 -- YES --&gt; Q2{{Check temp. sensor of D room indoor unit? TA sensor, TC sensor}}     Q2 -- Error --&gt; A2[Correct connector. Sensor error -&gt; Replace.]     Q2 -- OK --&gt; A3[Check outdoor P.C.B. MCC-5071 and indoor D room P.C. board. Defect -&gt; Replace.]   </pre>
	◎●●●●○●	<p><b>[PMV error for E room]</b></p> <pre> graph TD     Q1{{Is PMV under correct conditions?}} -- NO --&gt; A1[Repair defective position. Replace defective part.]     Q1 -- YES --&gt; Q2{{Check temp. sensor of E room indoor unit? TA sensor, TC sensor}}     Q2 -- Error --&gt; A2[Correct connector. Sensor error -&gt; Replace.]     Q2 -- OK --&gt; A3[Check outdoor P.C.B. MCC-5071 and indoor E room P.C. board. Defect -&gt; Replace.]   </pre>

# 11-7. Troubleshooting

## 11-7-1. How to Check Whether the Air Purifier is Good or Not

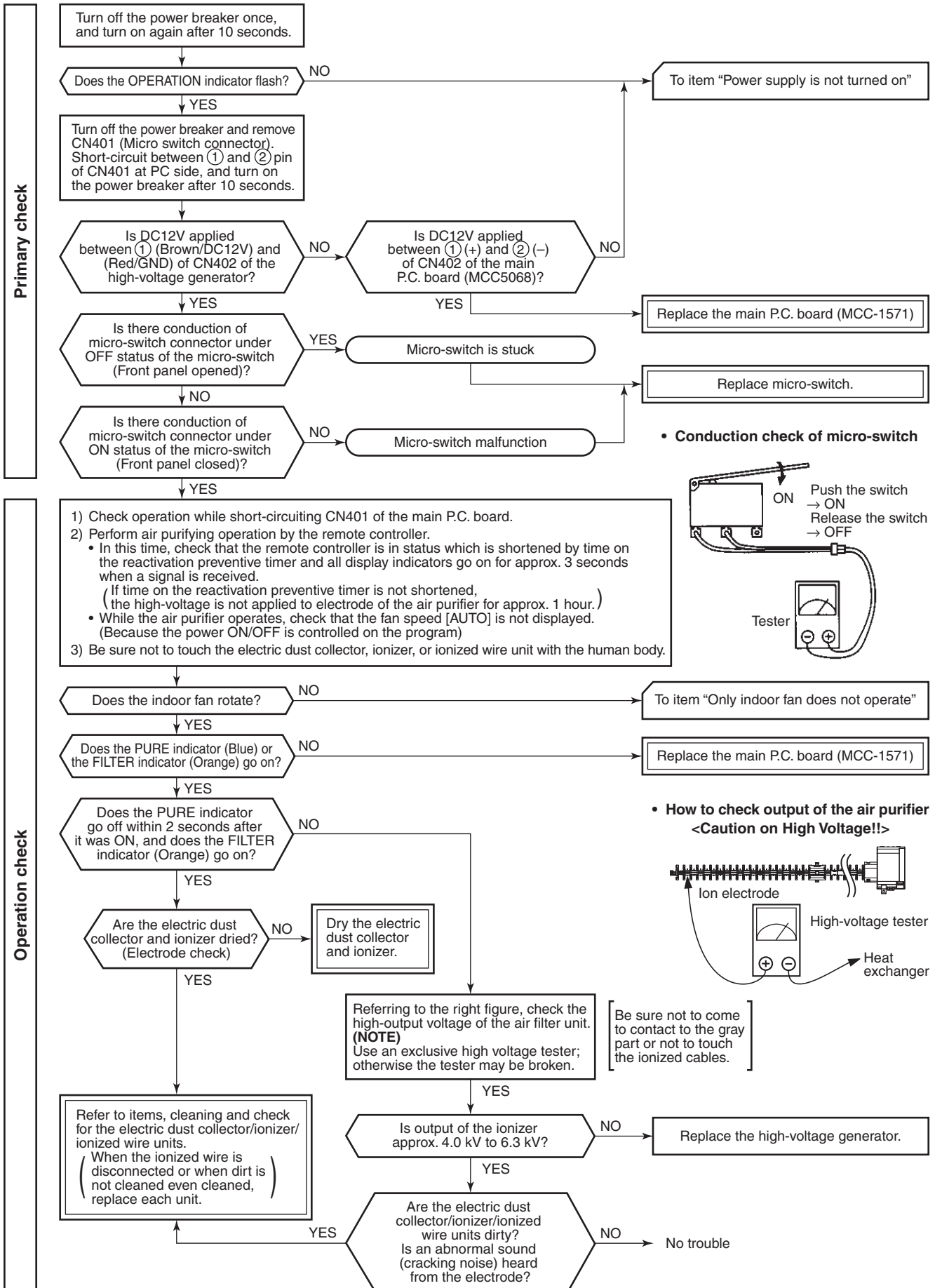



## 11-8. Inspection of the Main Parts

### 11-8-1. Inspection of the P.C. Board (Indoor Unit)



---

#### (1) Operating precautions

- 1) When removing the front panel or the P.C. board, be sure to shut off the power supply breaker.
- 2) When removing the P.C. board, hold the edge of the P.C. board and do not apply force to the parts.
- 3) When connecting or disconnecting the connectors on the P.C. board, hold the whole housing. Do not pull at the lead wire.

#### (2) Inspection procedures

- 1) When a P.C. board is judged to be defective, check for disconnection, burning, or discoloration of the copper foil pattern or this P.C. board.
  - 2) The P.C. board consists of the following 2 parts
    - a. **Main P.C. board part :**  
DC power supply circuit (5V, 12V, 35V), Indoor fan motor control circuit, CPU and peripheral circuits, buzzer, and Driving circuit of louver.
    - b. **Indication unit of infrared ray receiving infrared ray receiving circuit, LED :**  
To check defect of the P.C. board, follow the procedure described below.
-

### (3) Check procedures

Table 11-8-1

No.	Procedure	Check points	Causes
1	Turn off the power supply breaker and remove the P.C. board assembly from electronic parts base. Remove the connecting cables from the terminal block.	Check whether or not the fuse (F01) is blown.	Impulse voltage was applied or the indoor fan motor short-circuited.
2	Remove the connector of the motor and turn on the power supply breaker. If OPERATION indicator flashes (once per second), it is not necessary to check steps (1 to 3) in the right next column.	Check power supply voltage : 1. Between No. 1 and No. 3 of CN301 (AC 220–240V) 2. Between ⊕ and ⊖ of C03 (DC 310–340V) 3. Between ⊖ of IC122 and output side of IC122 (DC 15V) 4. Between 12V and GND 5. Between 5V and GND	1. The terminal block or the crossover cable is connected wrongly. 2. The capacitor (C01), line filter (L01), resistor (R02), or the diode (DB01) is defective. 3. IC101, IC122 and T101 are defective. 4. IC101, IC121, IC122 and T101 are defective.
3	Push [START/STOP] button once to start the unit. (Do not set the mode to On-Timer operation.)	Check power supply voltage : 1. Between CN03 and CN501 (DC 15–60V)	IC501 and IC502 are defective.
4	Shorten the restart delay timer and start unit.	Check whether or not all indicators (OPERATION, TIMER, PURE) are lit for 3 seconds and they return to normal 3 seconds later.	The indicators are defective or the housing assembly (CN261) is defective.
5	Push [START/STOP] button once to start the unit, • Shorten the restart delay timer. • Set the operation mode to COOL. • Set the fan speed level to AUTO. • Set the preset temperature much lower than the room temperature. (The unit (compressor) operates continuously in the above condition.)	1. Check whether or not the compressor operates. 2. Check whether or not the OPERATION indicator flashes.	1. The temperature of the indoor heat exchanger is extremely low. 2. The connection of the heat exchanger sensor is loose. (The connector is disconnected.) (CN602) 3. The heat exchanger sensor and the P.C. board are defective. (Refer to Table 11-3-1.) 4. The main P.C. board is defective.
6	If the above condition (No. 5) still continues, start the unit in the following condition. • Set the operation mode to HEAT. • Set the preset temperature much higher than room temperature.	1. Check whether or not the compressor operates. 2. Check whether or not the OPERATION indicator flashes.	1. The temperature of the indoor heat exchanger is extremely high. 2. The connection of the heat exchanger sensor short-circuited. (CN602) 3. The heat exchanger sensor and the P.C. board are defective. (Refer to Table 11-3-1.) 4. The main P.C. board is defective
7	Connect the motor connector to the motor and turn on the power supply. Start the unit the following condition. • Set the fan speed level to HIGH. (The unit (compressor) operates continuously in the above condition in No. 5.)	1. Check it is impossible to detect the voltage (DC 15V) between 3 and 4 of the motor terminals. 2. The motor does not operate or the fan motor does not rotate with high speed. (But it is possible to receive the signal from the remote controller.) 3. The motor rotates but vibrates strongly.	1. The indoor fan motor is defective. (Protected operation of P.C. board.) 2. The P.C. board is defective. 3. The connection of the motor connector is loose.

11-8-2. P.C. Board Layout

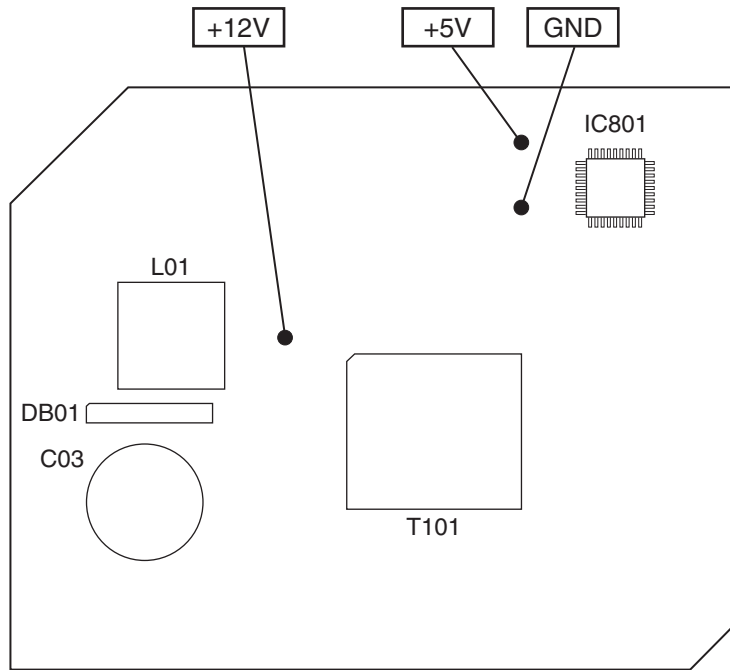

[1] Sensor characteristic table

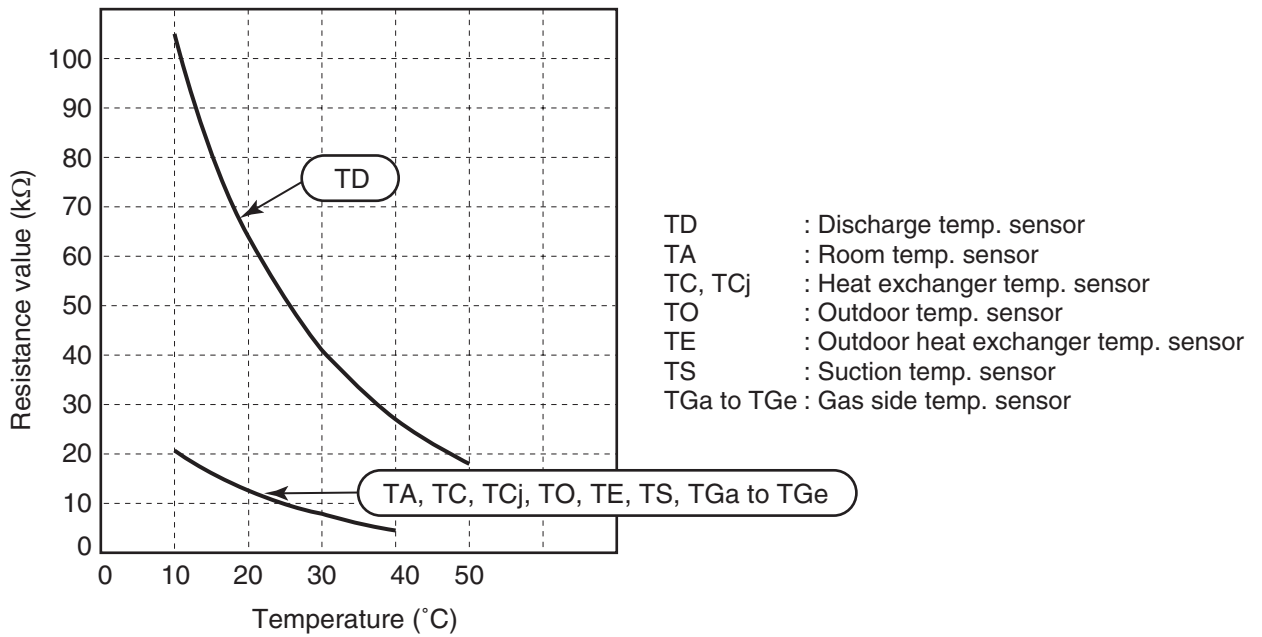

### 11-8-3. Indoor Unit (Other Parts)

No.	Part name	Checking procedure												
1	Room temp. (TA) sensor Heat exchanger (TC) sensor Heat exchanger (TCj) sensor	<p>Disconnect the connector and measure the resistance value with tester. (Normal temp.)</p> <table border="1"> <thead> <tr> <th>Sensor \ Temperature</th> <th>10°C</th> <th>20°C</th> <th>25°C</th> <th>30°C</th> <th>40°C</th> </tr> </thead> <tbody> <tr> <td>TA, TC, TCj (kΩ)</td> <td>20.7</td> <td>12.6</td> <td>10.0</td> <td>7.9</td> <td>4.5</td> </tr> </tbody> </table>	Sensor \ Temperature	10°C	20°C	25°C	30°C	40°C	TA, TC, TCj (kΩ)	20.7	12.6	10.0	7.9	4.5
Sensor \ Temperature	10°C	20°C	25°C	30°C	40°C									
TA, TC, TCj (kΩ)	20.7	12.6	10.0	7.9	4.5									
2	Remote controller	Refer to page 102. Troubleshooting for Remote Controller												
3	Louver motor (right, left, Horizontal) MP24Z3N	<p>Measure the resistance value of each winding coil by using the tester. (Under normal temperature 25°C)</p> <table border="1"> <thead> <tr> <th>Position</th> <th>Resistance value</th> </tr> </thead> <tbody> <tr> <td>1 to 2</td> <td rowspan="4">250 ± 20Ω</td> </tr> <tr> <td>1 to 3</td> </tr> <tr> <td>1 to 4</td> </tr> <tr> <td>1 to 5</td> </tr> </tbody> </table>	Position	Resistance value	1 to 2	250 ± 20Ω	1 to 3	1 to 4	1 to 5					
Position	Resistance value													
1 to 2	250 ± 20Ω													
1 to 3														
1 to 4														
1 to 5														
4	Louver motor (Moving panel) MP24Z4N	<p>Measure the resistance value of each winding coil by using the tester. (Under normal temp. 25°C)</p> <table border="1"> <thead> <tr> <th>Position</th> <th>Resistance value</th> </tr> </thead> <tbody> <tr> <td>1 to 2</td> <td rowspan="4">200 ± 20Ω</td> </tr> <tr> <td>1 to 3</td> </tr> <tr> <td>1 to 4</td> </tr> <tr> <td>1 to 5</td> </tr> </tbody> </table>	Position	Resistance value	1 to 2	200 ± 20Ω	1 to 3	1 to 4	1 to 5					
Position	Resistance value													
1 to 2	200 ± 20Ω													
1 to 3														
1 to 4														
1 to 5														
5	Indoor fan motor	<p>Refer to page 100. Only the Indoor Motor Fan Does not Operate. Refer to page 101. Indoor Fan Motor Automatically Starts to Spin by Turning on Power Supply.</p>												

### 11-8-4. Outdoor Unit

No.	Part name	Checking procedure																								
1	Compressor (Model : DA270A2F-20L)	<p>Measure the resistance value of each winding by using the tester.</p> <table border="1"> <thead> <tr> <th>Position</th> <th>Resistance value</th> </tr> </thead> <tbody> <tr> <td>Red - White</td> <td rowspan="3">0.49 ± 0.03Ω</td> </tr> <tr> <td>White - Black</td> </tr> <tr> <td>Black - Red</td> </tr> </tbody> </table> <p style="text-align: right;">Under 20°C</p>	Position	Resistance value	Red - White	0.49 ± 0.03Ω	White - Black	Black - Red																		
Position	Resistance value																									
Red - White	0.49 ± 0.03Ω																									
White - Black																										
Black - Red																										
2	Outdoor fan motor (Model : ICF-280-A100-1)	<p>Measure the resistance value of winding by using the tester.</p> <table border="1"> <thead> <tr> <th>Position</th> <th>Resistance value</th> </tr> </thead> <tbody> <tr> <td>Red - White</td> <td rowspan="3">13.3 to 16.3 kΩ</td> </tr> <tr> <td>White - Black</td> </tr> <tr> <td>Black - Red</td> </tr> </tbody> </table> <p style="text-align: right;">For details, refer to Section 11-10.</p>	Position	Resistance value	Red - White	13.3 to 16.3 kΩ	White - Black	Black - Red																		
Position	Resistance value																									
Red - White	13.3 to 16.3 kΩ																									
White - Black																										
Black - Red																										
3	Compressor thermo. Bimetal type (Model : US622KXTMQO)	Check conduction by using the tester.																								
4	Outdoor temperature sensor (TO), pipe temperature sensor (TGa, TGb, TGc, TGd, TGe), discharge temperature sensor (TD), suction temperature sensor (TS), evaporator temperature sensor (TE),	<p>Disconnect the connector, and measure resistance value with the tester. (Normal temperature)</p> <table border="1"> <thead> <tr> <th>Sensor \ Temperature</th> <th>10°C</th> <th>20°C</th> <th>25°C</th> <th>40°C</th> <th>50°C</th> </tr> </thead> <tbody> <tr> <td>TD (kΩ)</td> <td>105</td> <td>64</td> <td>51</td> <td>27</td> <td>18</td> </tr> <tr> <td>TO, TE, TS (kΩ)</td> <td>20.6</td> <td>12.6</td> <td>10.0</td> <td>5.1</td> <td>3.4</td> </tr> <tr> <td>TGa to TGe (kΩ)</td> <td>20.0</td> <td>12.5</td> <td>10.0</td> <td>5.3</td> <td>3.6</td> </tr> </tbody> </table>	Sensor \ Temperature	10°C	20°C	25°C	40°C	50°C	TD (kΩ)	105	64	51	27	18	TO, TE, TS (kΩ)	20.6	12.6	10.0	5.1	3.4	TGa to TGe (kΩ)	20.0	12.5	10.0	5.3	3.6
Sensor \ Temperature	10°C	20°C	25°C	40°C	50°C																					
TD (kΩ)	105	64	51	27	18																					
TO, TE, TS (kΩ)	20.6	12.6	10.0	5.1	3.4																					
TGa to TGe (kΩ)	20.0	12.5	10.0	5.3	3.6																					

## 11-9. How to Simply Judge Whether Outdoor Fan Motor is Good or Bad

### 1. Symptom

- Outdoor fan motor does not rotate.
  - Outdoor fan motor stops within several tens seconds though it started rotating.
  - Outdoor fan motor rotates or does not rotate according to the position where the fan stopped, etc.
- Remote controller check code "02 : Outdoor block, 1A : Outdoor fan drive system error"

### 2. Cause

The following causes are considered when the outdoor fan motor does not normally rotate.

- 1) Mechanical lock of the outdoor fan motor
  - 2) Winding error of the outdoor fan motor
  - 3) Position-detect circuit error inside of the outdoor fan motor
- or
- 4) Motor drive circuit error of the outdoor P.C. board

### 3. How to simply judge whether outdoor fan motor is good or bad

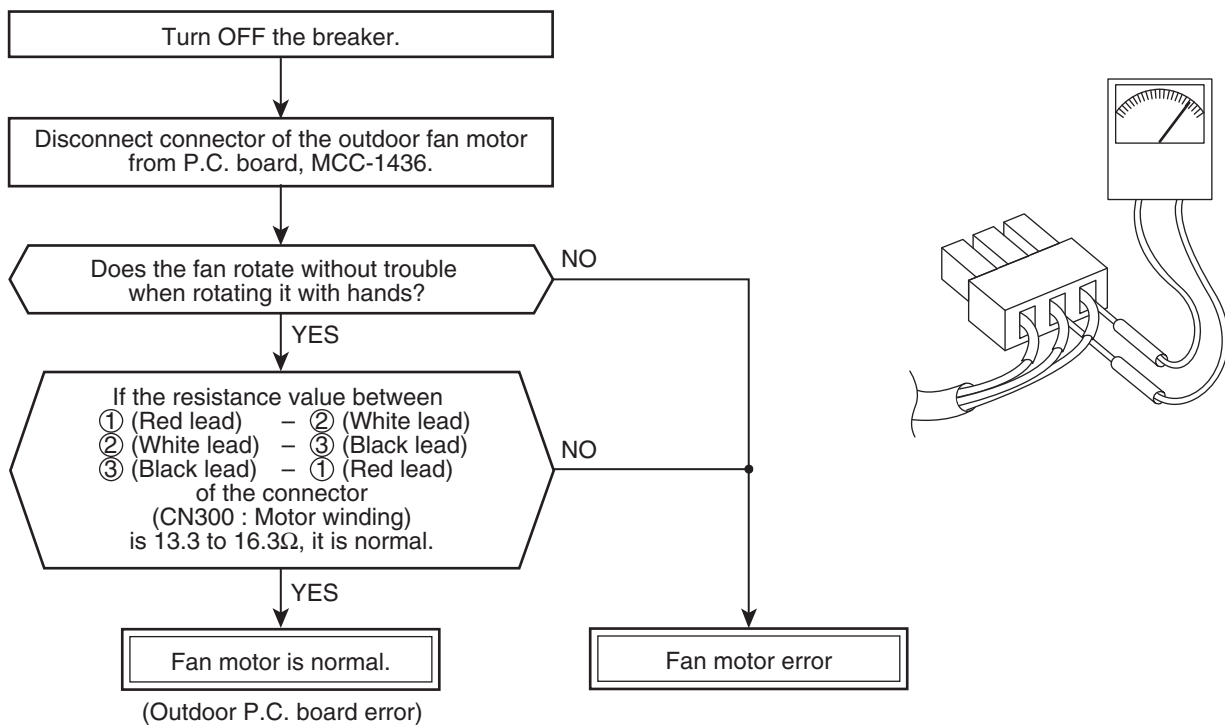

### NOTE

However, GND circuit error inside of the motor may be accepted in some cases when the above check is performed.

When the fan motor does not become normal even if P.C. board is replaced, replace the outdoor fan motor.

<MCC-1571>

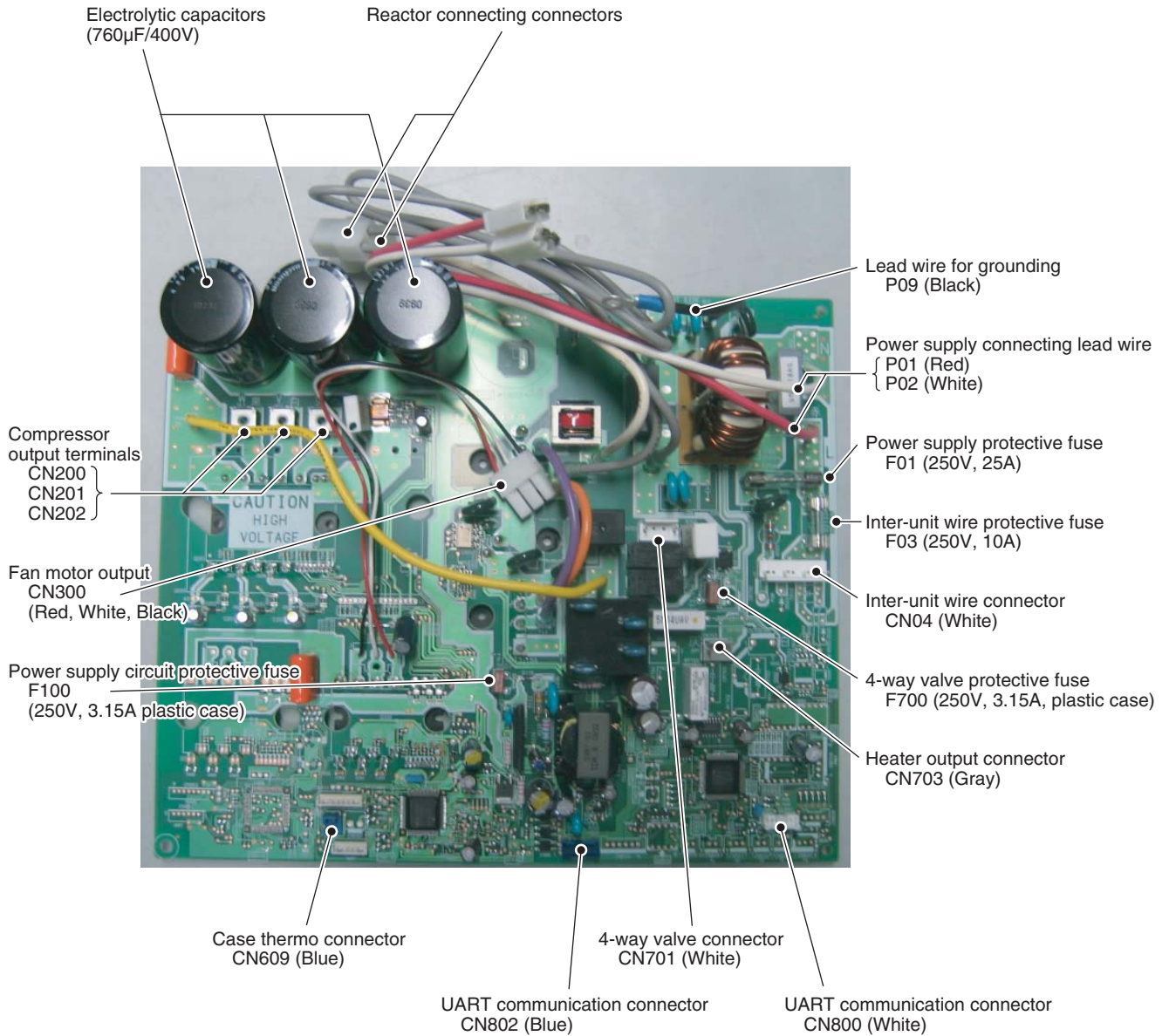





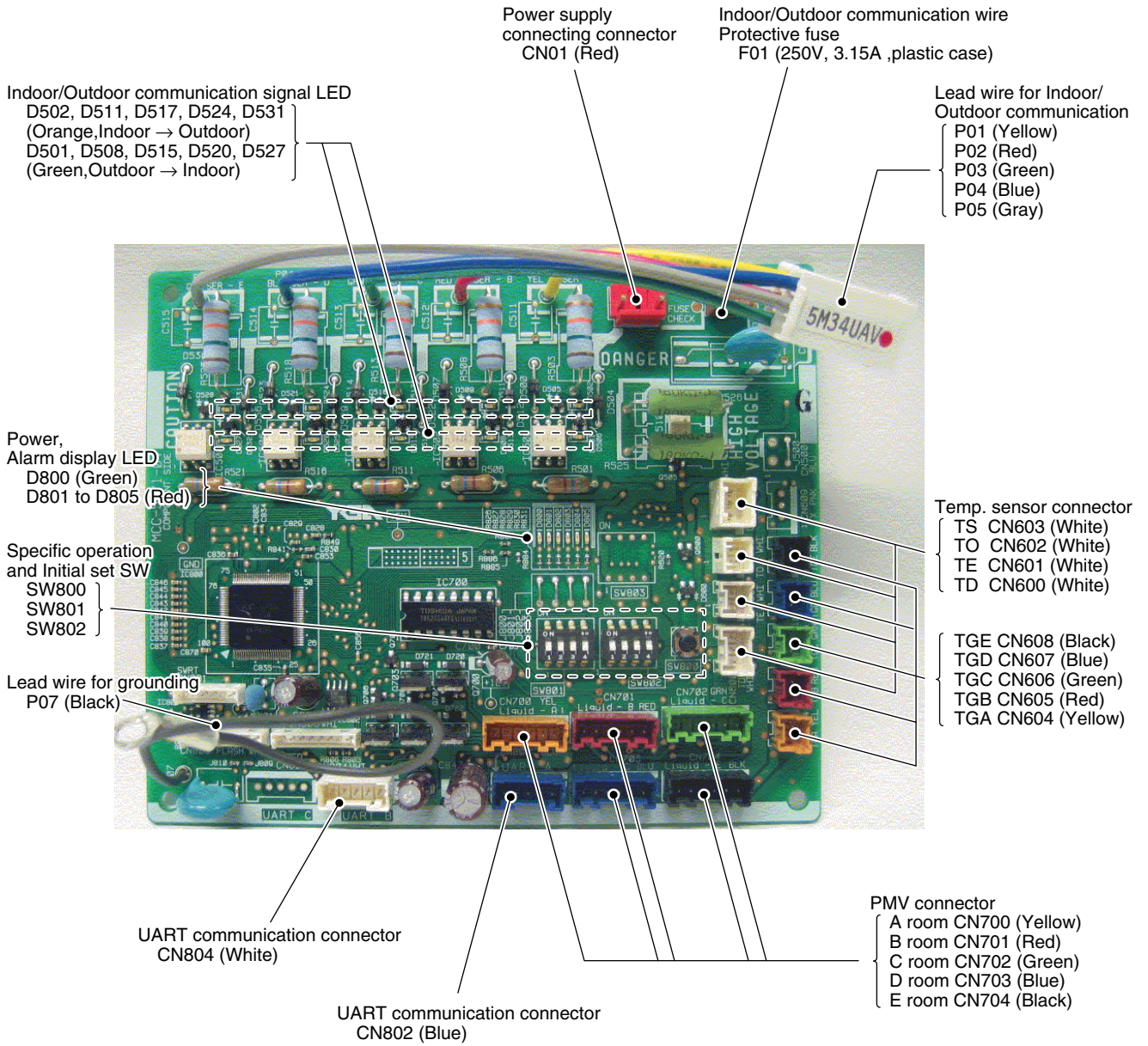

<MCC-5071>







## 12. HOW TO REPLACE THE MAIN PARTS

### 12-1. Indoor Unit

 <b>WARNING</b>	
	Since high voltages is applied to electrical parts, turn off the power without fail before starting replacement work.
 CHECK	<b>After repairs have been completed and the front panel and cabinet have been attached, perform test run and check for smoke, unusual sound, and other abnormalities.</b> Failure to do so may cause fire or electric shock. Make sure that the cabinet is attached before starting test run.
 WATCH OUT FOR FIRE	<b>Perform the following when repairing the refrigeration cycle.</b> <ul style="list-style-type: none"> <li>• Watch out for fire in the surrounding area. If a gas stove or other appliance is being used, extinguish the flames before starting work. If the flames are not extinguished, they may ignite oil mixed with the refrigerant gas and may cause fire or burn injury.</li> <li>• Do not use welding equipment in an airtight room. Carbon monoxide poisoning may be caused if the room is not well ventilated.</li> <li>• Do not use welding equipment near flammable materials. Flames from the equipment may cause the flammable materials to catch fire and may result in fire or burn injury.</li> </ul>

 <b>CAUTION</b>	
 WEAR GLOVES	<b>Wear thick gloves such as cotton work gloves during repair work.</b> Failure to do so may cause injury by parts.

#### 12-1-1. Removing the Front Panel and Moving Panel

- 1) Open the moving panel, and support the moving panel by the panel support on the right side.

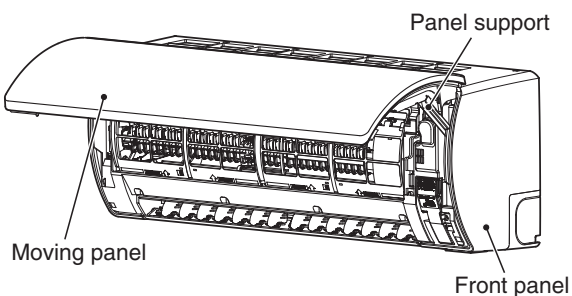

Fig. 12-1-1

- 2) Remove the four set screws on the front panel.

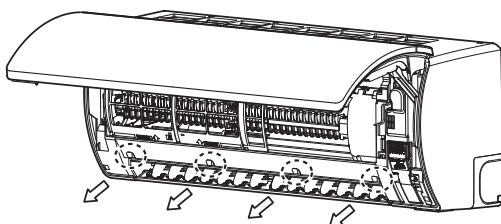

Fig. 12-1-2

- 3) Insert your thumb into the air outlet bottom section, and lift up the front panel bottom.

- 4) Close the moving panel to remove the clips on the top side as shown below.

Push your finger down on the clip on the front panel top, and lift up the panel back edge so that the clip is released (5 locations).

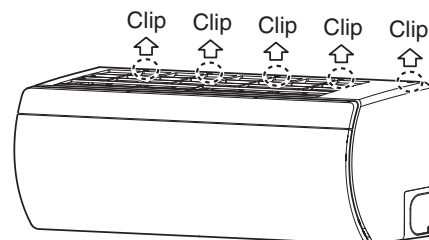

Fig. 12-1-3

### 12-1-2. Fixing Frame Assembly

- 1) Detach the two air filters.
- 2) Disconnect the plasma ion charger connector and the earth lead (black). (The earth lead is connected to the heat exchanger with a screw.)
- 3) Remove the two screws securing the fixing frame to the rear of the indoor unit.

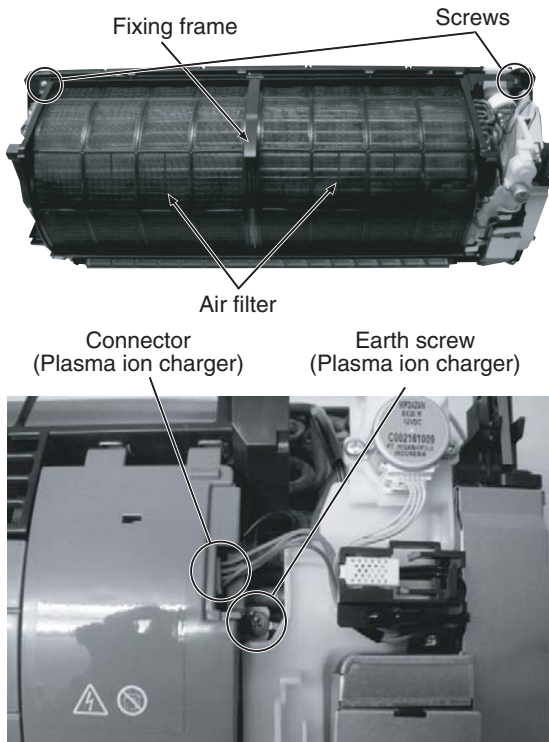

Fig. 12-1-4

- 4) While turning the upper part of the fixing frame to the front, release the front claw of the fixing frame from the rear of the indoor unit.

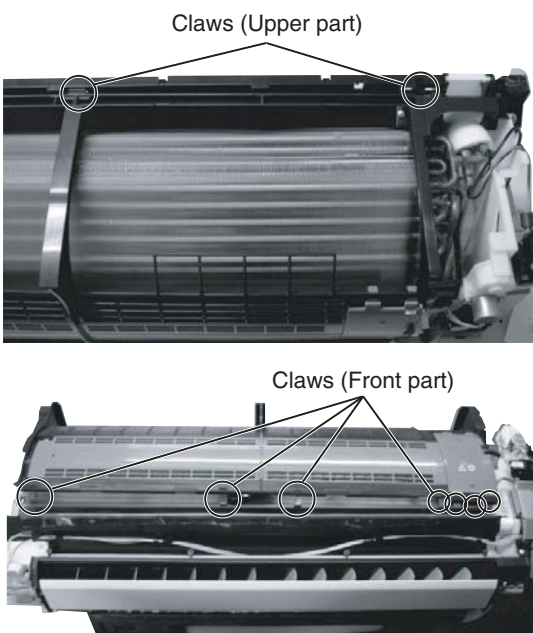

Fig. 12-1-5

### 12-1-3. Electric Parts Cover Detached

- 1) Perform work of Detachment 12-1-1. **Removing the Front Panel and Moving Panel.**
- 2) Remove the screw beside the screw that secures the electric parts box assembly.
- 3) Remove the connector cover screws and detach the connector cover.
- 4) While pushing the claw of the lead wire cover in the direction shown in the figure, lift the bottom of the lead wire cover to detach it.
- 5) Disconnect the connectors below.
  - Louver motor connector (24P) for louver
  - Fan motor connector (5P)
  - Louver motor connector (5P) for movable panel
  - Minus ion charger connector (4P)
- 6) Remove the motor base assembly by releasing the claw.
- 7) Remove the earth screw, TC sensor, and TCj sensor.

### CAUTION

#### When attaching the electric parts assembly

- Insert the projection at the rear of the indoor unit into the upper hole in the electric parts assembly.
- Check that the fan motor lead wires are connected as shown in the figure.

#### When attaching the motor base assembly

- Before attaching the motor base assembly, connect the earth wire and install the TC and TCj sensors.
- Insert the bottom of the motor base assembly into the portion shown in the figure.
- Insert the motor cover projection into the hole in the right side panel of the motor base assembly.

### 12-1-4. Microcomputer P.C. Board

- 1) Remove the electric parts cover screw.
- 2) Detach the metal electric parts cover.
- 3) Disconnect the connectors from the P.C. board.
- 4) Disconnect the solderless terminals from the P.C. board.
- 5) Remove the P.C. board.

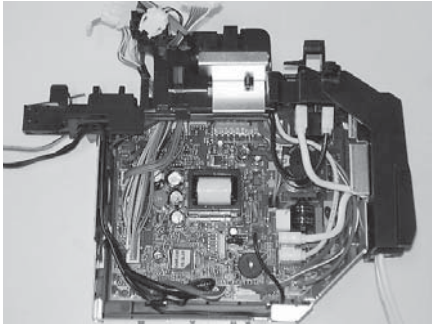

Electric parts cover detached

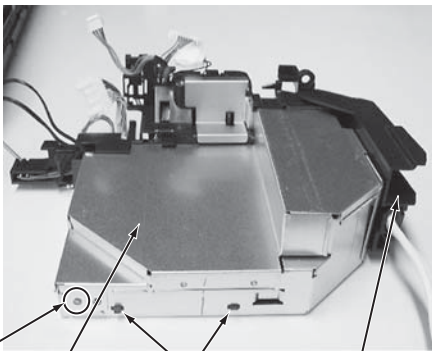

Screw Electric parts cover Claw (2 locations) Sub-base

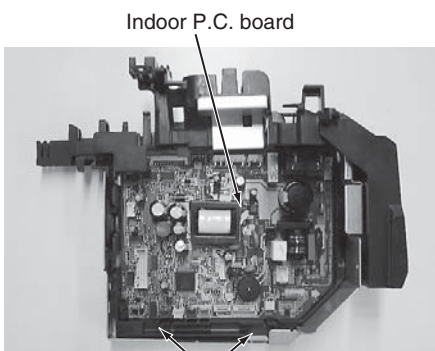

Indoor P.C. board Claw (2 locations)

**Fig. 12-1-6**

### 12-1-5. Louver

- 1) Open the moving panel, and support it with the panel support.
- 2) Open the vertical air flow louver.
- 3) Insert a flathead screwdriver into the gap of the louver fixture on the right and left ends of the vertical air flow louver, and turn in the counter-clockwise direction to remove.

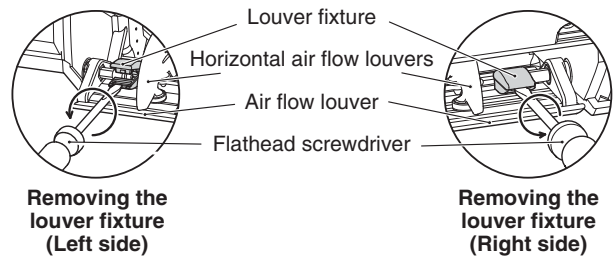

Removing the louver fixture (Left side)

Removing the louver fixture (Right side)

**Fig. 12-1-7**

- 4) After pushing in the right and left connector joints, remove the vertical air flow louvers. Remove the centre joint and bend the louver downward. Remove the right side joint first, and then, remove the left side joint

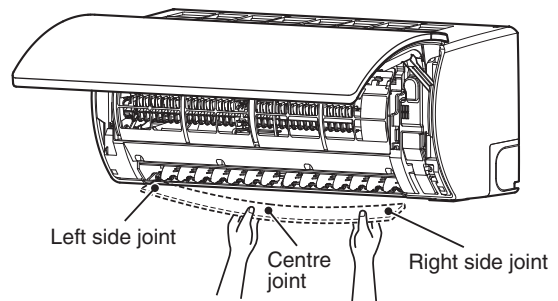

Left side joint Centre joint Right side joint

**Fig. 12-1-8**

### 12-1-6. Heat Exchanger

- 1) Perform work of Detachment 12-1-1. **Removing the Front Panel and Moving Panel** and 12-1-2. **Fixing Frame Assembly**.
- 2) Remove the pipe holder at the rear of the unit.
- 3) Remove the two fixing screws (10 mm) at the left of the heat exchanger.
- 4) Remove the fixing screw of the heat exchanger fixing holder (upper).
- 5) Remove the fixing screw of the heat exchanger fixing holder (lower).
- 6) Release the end plate hook and the claw at the right of the heat exchanger, pull up the heat exchanger, and then remove the fixing holder (lower) from the guide of the indoor unit.

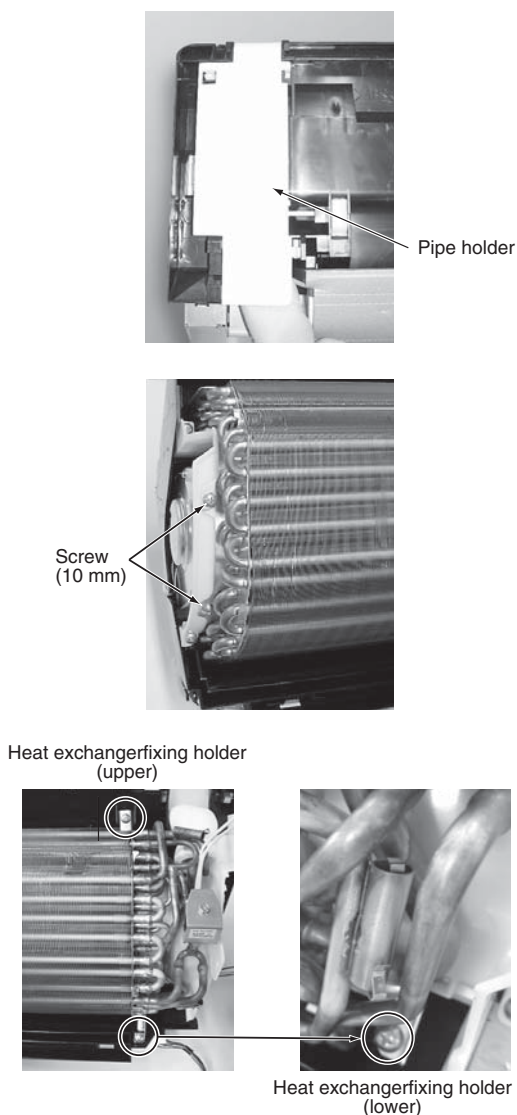

Fig. 12-1-9

### CAUTION

Check that the claw is engaged with the end plate hook, and then secure the heat exchanger with screws.

### 12-1-7. Fan Motor

- 1) Perform work of Detachment 12-1-1. **Removing the Front Panel and Moving Panel** and 12-1-3. **Electric Parts Cover Detached**.
- 2) Loosen the hexagon socket set screw of the cross flow fan from the air outlet.
- 3) Remove the two fixing screws of the motor band (right).
- 4) Pull the motor band (right) and the fan motor out of the unit.

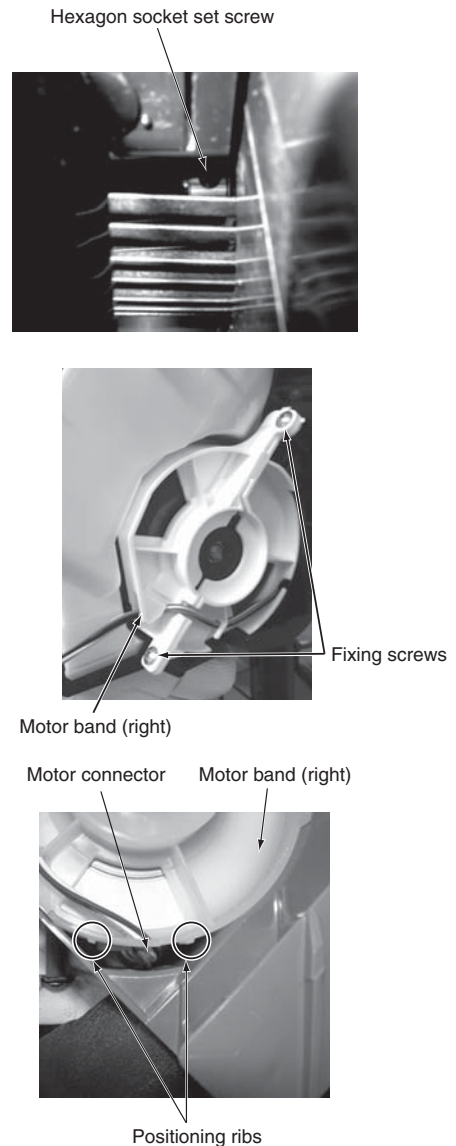

Fig. 12-1-10

### CAUTION

Install the fan motor while positioning it so that the fan motor connector comes between the positioning ribs on the motor band (right).

Be sure to tighten the hexagon socket set screw so that it touches the D-cut surface of the fan motor shaft.



## 12-1-8. Cross Flow Fan

- 1) Perform work of Detachment 11-1-1. **Removing the Front Panel and Moving Panel** and 11-1-2. **Fixing Frame Assembly**.
- 2) Remove the two fixing screws (10 mm) at the left of the heat exchanger end plate, and then remove the two fixing screws (12 mm) of the bearing base assembly.
- 3) Remove the bearing base while lifting the heat exchanger.
- 4) Remove the cross flow fan while lifting the heat exchanger.

Screws (12 mm)

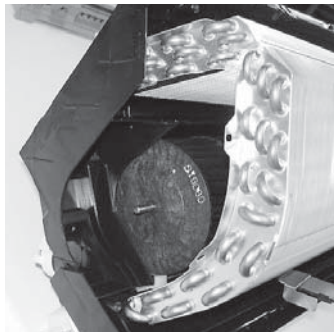
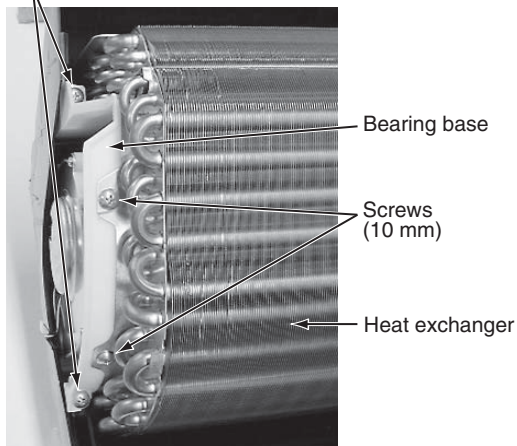

Fig. 12-1-11

### CAUTION

Check and perform items 1 and 2 in the following right side.

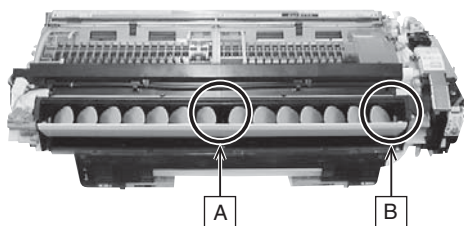

Fig. 12-1-12

- 1 **Keep 27mm distance between the support shaft at the rear centre of the unit and the immediate right joint-section of the cross flow fan.**

#### Detail A

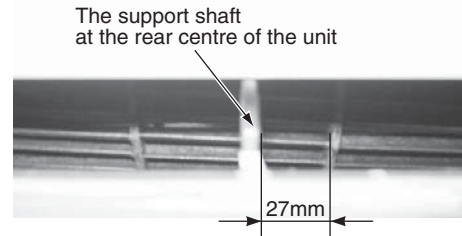

Fig. 12-1-13

- 2 **Check that the fan motor shaft end projects by 9 mm above the screw boss of the cross flow fan.** If the motor shaft end is below the screw boss, the cross flow fan may have been assembled improperly. Check again whether the cross flow fan have been assembled properly.

#### Detail B

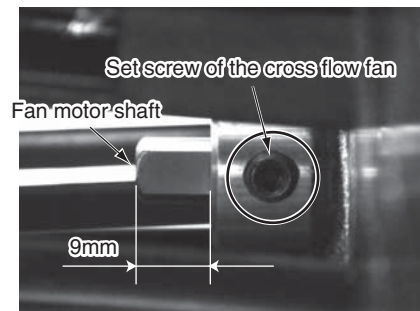

Fig. 12-1-14

- 3 **Be sure to tighten the hexagon socket set screw so that it touches the D-cut surface of the fan motor shaft.**

## 12-2. Plasma Ion Charger

### 12-2-1. Common Procedure

- 1) Perform work of Detachment 12-1-1. **Removing the Front Panel and Moving Panel** for the indoor unit.
- 2) Detach the two air filters.

### 12-2-2. Protective Board

- 1) Remove the screw shown in the figure.
- 2) Shift the protective board to the left.
- 3) Pull the protective board toward you to remove it.

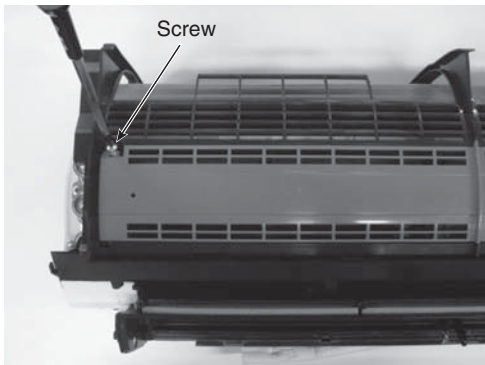

Fig. 12-2-1

### 12-2-3. High-voltage Power Supply Unit and Discharger Unit

- 1) Perform work of Detachment 12-1-1. **Removing the Front Panel and Moving Panel**.
- 2) Disconnect the 4P connector on the high-voltage power supply unit.
- 3) Remove the screw securing the earth lead (black).
- 4) While pushing down the hook at the upper part of the high-voltage power supply unit, detach the upper part of the power supply unit.
- 5) Lift the high-voltage power supply unit, and pull the projection at the bottom of the high-voltage power supply unit out of the fixing frame.

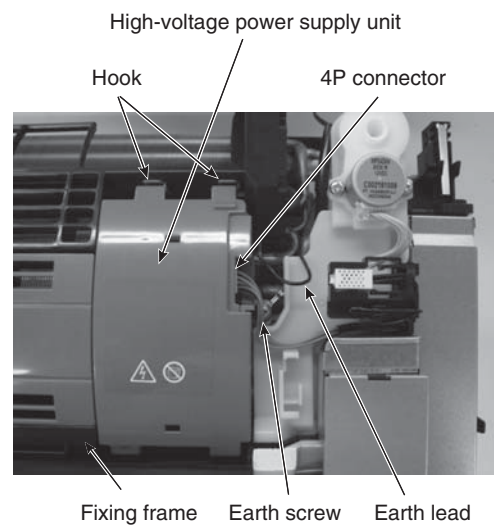

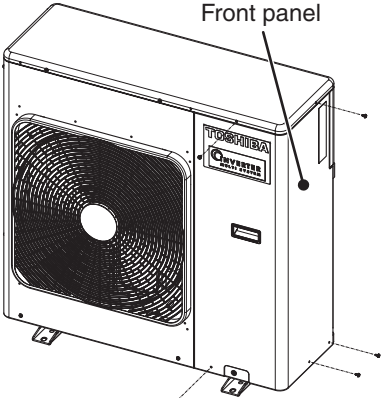

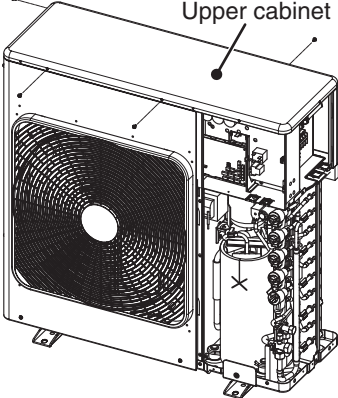

Fig. 12-2-2

## CAUTION

Carry out this work taking care of the end of the sheet metal on the back of the discharger unit.

- 6) Gently warp the centre of the discharger unit downward, and disengage the upper projection from the fixing frame.
- 7) Gently warp the centre of the discharger unit upward, and disengage the lower projection from the fixing frame.
- 8) Hold the hook at the left of the discharger unit, and lift the discharger unit to remove it.

## 12-3. Outdoor Unit

No.	Part name	Procedure	Remarks
①	Common procedure	<p style="text-align: center;"><b>CAUTION</b></p> <hr/> <p>Never forget to put on the gloves at working time; otherwise an injury will be caused by the parts etc.</p> <hr/> <p><b>1. Detachment</b></p> <ol style="list-style-type: none"> <li>1) Stop operation of the air conditioner, and turn off the switch of the breaker.</li> <li>2) Remove the front panel. (Hexagonal screw <math>\varnothing 4 \times 10</math>, 5 pcs.) <ul style="list-style-type: none"> <li>• After taking off screws, draw the front panel ② to this side and remove it while pulling the front panel downward ① .</li> </ul> </li> <li>3) Remove the power supply cable and the indoor/outdoor connecting wire from the cord clamp and the terminal.</li> <li>4) Remove the upper cabinet. (Hexagonal screw <math>\varnothing 4 \times 10</math>, 4 pcs.)</li> </ol> <p><b>2. Attachment</b></p> <ol style="list-style-type: none"> <li>1) Mount the upper cabinet. (Hexagonal screw <math>\varnothing 4 \times 10</math>, 4 pcs.) In this time, insert the fin guard at rear side between the front panel and the heat exchanger (at rear side).</li> <li>2) Connect the power supply cable and the indoor/outdoor connecting wire to the terminal and then fix them with the cord clamp.</li> <li>3) Mount the front panel. (Hexagonal screw <math>\varnothing 4 \times 10</math>, 5 pcs.)</li> </ol>	 <p>Front panel</p>  <p>Front panel</p> <p>① Downward</p> <p>② This side</p>  <p>Upper cabinet</p> <p>Insert the fin guard at rear side between the front panel and the heat exchanger (at rear side).</p> 

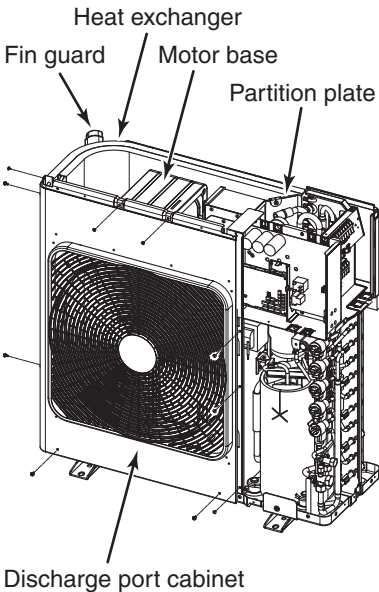
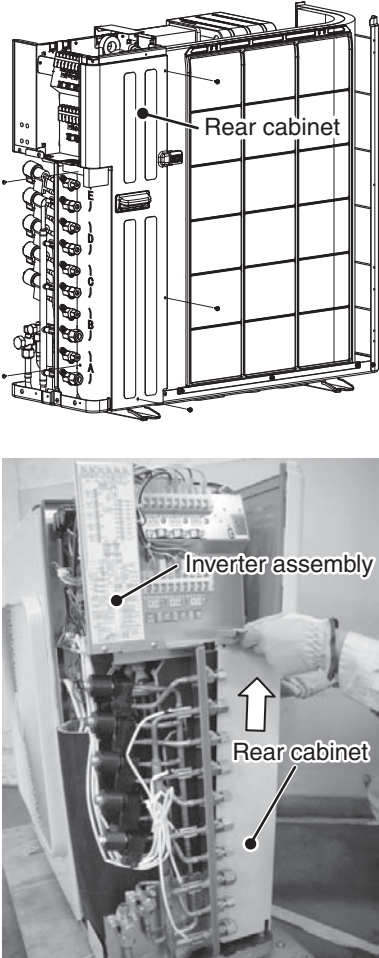

No.	Part name	Procedure	Remarks
②	Discharge port cabinet	<p><b>1. Detachment</b></p> <ol style="list-style-type: none"> <li>1) Perform work of Detachment 1 of ① .</li> <li>2) Take off screws for the discharge port cabinet and the partition plate. (ST1T Ø4 × 8, 3 pcs.)</li> <li>3) Take off screws for the discharge port cabinet and the bottom plate. (Hexagonal screw Ø4 × 10, 2 pcs.)</li> <li>4) Take off screws for the discharge port cabinet and the motor base. (ST1T Ø4 × 8, 2 pcs.)</li> <li>5) Take off screw for the discharge port cabinet and the heat exchanger. (ST1T Ø4 × 8, 1 pc.)</li> <li>6) Take off screws for the discharge port cabinet and the fin guard. (Hexagonal screw Ø4 × 10, 2 pcs.)</li> </ol>	
③	Rear cabinet	<p><b>1. Detachment</b></p> <ol style="list-style-type: none"> <li>1) Perform work of Detachment 1 of ① .</li> <li>2) Take off screw for the rear cabinet and the valve fixed board. (Hexagonal screw Ø4 × 10, 2 pcs.)</li> <li>3) Take off screw for the rear cabinet and the anchor board. (Hexagonal screw Ø4 × 10, 1 pc.)</li> <li>4) Take off screws for the rear cabinet and the heat exchanger. (Hexagonal screw Ø4 × 10, 2 pcs.)</li> <li>5) Remove the rear cabinet by shifting it obliquely backward and upward.</li> </ol>	

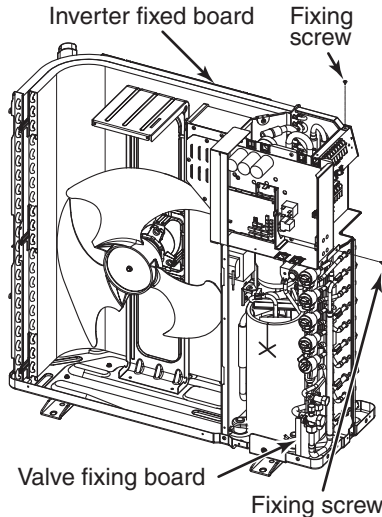
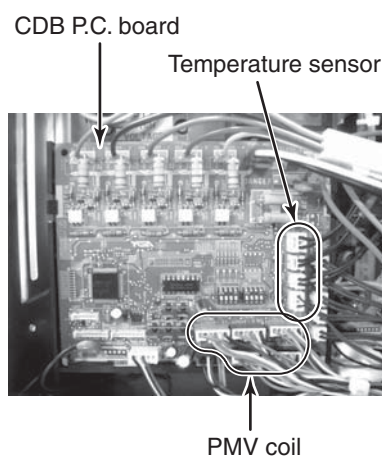
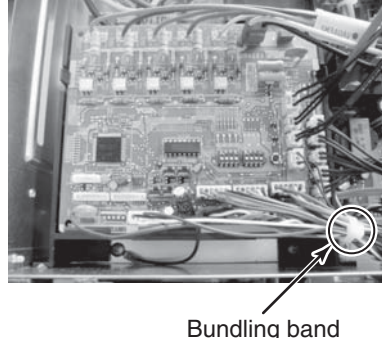
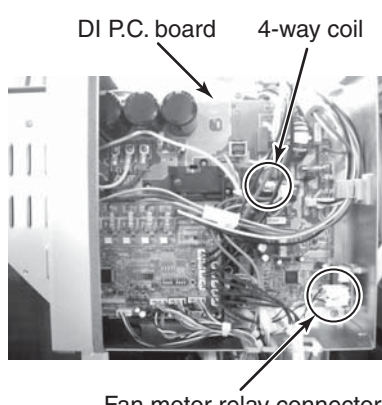
No.	Part name	Procedure	Remarks
④	Inverter assembly	<p>1) Perform works Detachment 1 of ① and ③ .</p> <p style="text-align: center;"><b>⚠ WARNING</b></p> <hr/> <p>Never disassemble the inverter until 5 minutes after the power supply was turned off because there is a fear that an electric shock may occur.</p> <hr/> <p><b>NOTE)</b></p> <hr/> <p>When working, be sure to use the insulate tools and put on the insulated gloves.</p> <hr/> <p>2) Take off screw for the inverter assembly and the valve fixed board. (ST1T Ø4 × 8, 1 pc.)</p> <p>3) Take off the screw fixed to the terminal fixed board in order to remove the inverter fixed board. (ST1T Ø4 × 8, 1 pc.)</p> <p>4) Remove the connectors that are connected from CDB P.C. board to the other parts.            CN600: TD sensor (3P, White)            CN601: TE sensor (2P, White)            CN602: TO sensor (2P, White)            CN603: TS sensor (3P, White)            CH608: TGa sensor (2P, Black)            CH607: TGb sensor (2P, Blue)            CH606: TGc sensor (2P, Green)            CH605: TGd sensor (2P, Red)            CH604: TGe sensor (2P, Yellow)            CN704: PMV coil (6P, Black)            CN703: PMV coil (6P, Blue)            CN702: PMV coil (6P, Green)            CN701: PMV coil (6P, Red)            CN700: PMV coil (6P, Yellow)</p> <p>5) Cut the bundling band that binds the PMV coil and the relay lead wire.</p> <p>6) Remove the connectors, relay connector and the lead wire that are connected from DI P.C. board to the other parts.            CN701: 4-way valve coil (2P, White)            Relay connector for reactor to mount the partition plate (2P: White)            Relay connector for compressor case thermo. (2P: White)</p> <p>7) Remove connectors that are connected from the fan motor to the fan motor relay P.C. board.            • Unlock the lock of the housing unit and then remove the connectors.</p>	 <p>Inverter fixed board    Fixing screw</p> <p>Valve fixing board    Fixing screw</p>  <p>CDB P.C. board    Temperature sensor</p> <p>PMV coil</p>  <p>Bundling band</p> <p>DI P.C. board    4-way coil</p>  <p>Fan motor relay connector</p>

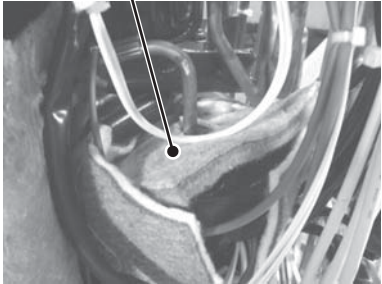
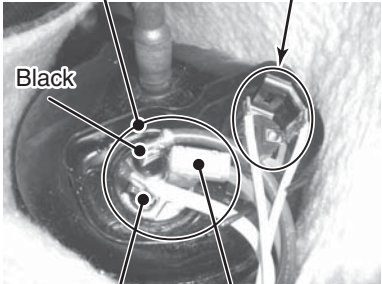
No.	Part name	Procedure	Remarks
④	Inverter assembly (Continued)	<p>8) Remove the soundproof plate (upper).</p> <p>9) Remove the terminal cover of the compressor and then remove the compressor lead of the compressor.</p> <p>10) Pull up the inverter assembly and then remove it.</p> <div style="text-align: center;"> </div> <p>* Hold up both the reactor cover side and the inverter box side and then remove the inverter assembly upward.</p> <p>* Caution to mount the inverter assembly            When mounting the inverter assembly to the partition plate, be sure to do hooking.</p> <div style="text-align: center;"> </div> <p><b>NOTE)</b></p> <hr/> <p>Using the bundling band on the market, be sure to bind the portions which were bound before.</p> <hr/>	<p>Soundproof plate (upper)</p>  <p>Compressor lead    Case thermo</p> 

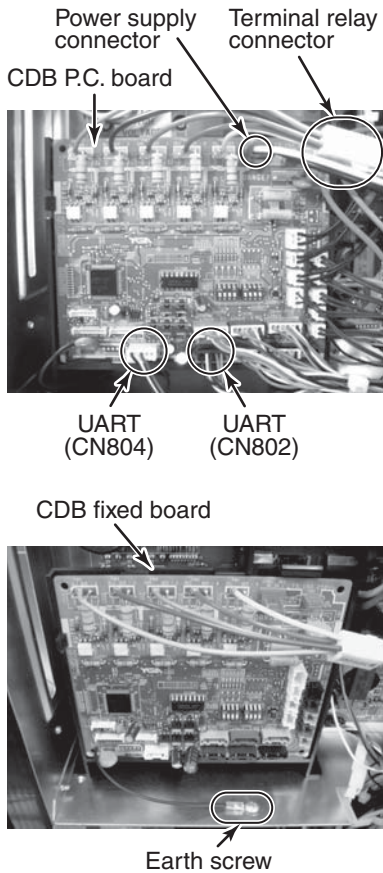
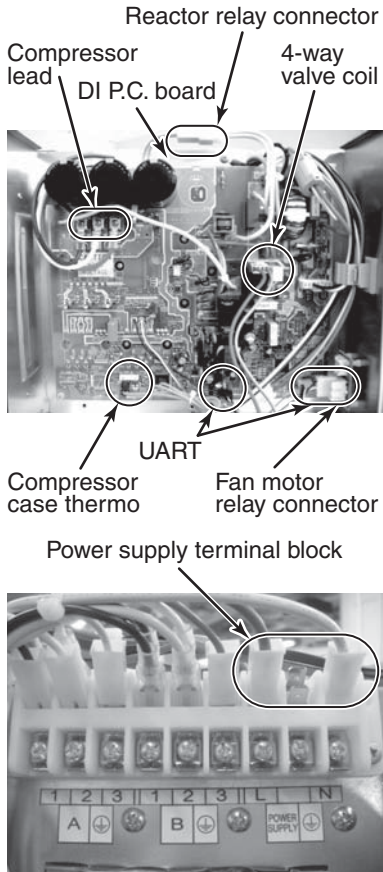
No.	Part name	Procedure	Remarks
⑤	CDB P.C. board	<p>1) Perform works of Detachment 1 of ① and 4) of ④ .</p> <p style="text-align: center;"><b>⚠ CAUTION</b></p> <hr/> <p>Never disassemble the inverter until 5 minutes after the power supply was turned off because there is a fear that an electric shock may occur.</p> <hr/> <p>2) Remove the connector and the relay connector that are connected from CDB P.C. board to DI P.C. board, power supply and the inter-unit wire.            CN802: UART (5P, Blue)            CN804: UART (5P, White)            CN01: Power supply (3P, Red)            Terminal relay connector (6P, White)            * Unlock the lock of the housing unit and then remove the connectors.</p> <p>3) Remove the earth wire of CDB P.C. board (Truss head B tight Ø4 × 6, 1 pc.)</p> <p>4) Remove CDB P.C. board from CDB fixed board.</p> <p>5) Mount a new CDB P.C. board.            * When connecting the connectors on CDB P.C. board to support CDB fixed board with hand.</p>	
⑥	DI P.C. board	<p>1) Perform works of Detachment 1 of ① , 3) of ② , ④ and 2), 3) of ⑤ .</p> <p style="text-align: center;"><b>⚠ CAUTION</b></p> <hr/> <p>Never disassemble the inverter until 5 minutes after the power supply was turned off because there is a fear that an electric shock may occur.</p> <hr/> <p>2) Take off screw for CDB fixed board and the inverter box. (ST1T Ø4 × 8, 1 pc.)</p> <p>3) Remove CDB P.C. board assembly.</p> <p>4) Remove the connectors connected to DI P.C. board. (4-way valve coil, compressor case thermo, UART × 2, Inter-unit wire)</p> <p>5) Remove the relay connector for fan motor and reactor.</p> <p>6) Remove the lead wire connected to DI P.C. board. (Tightening torque: 1.47 ± 0.1 N•m)</p> <p>Compressor lead    U : CN200, Red                                      V : CN201, White                                      W : CN202, Black</p> <p>Remove the power supply cable from the power supply terminal block.            Power supply lead L: Red            Power supply lead N: White</p>	



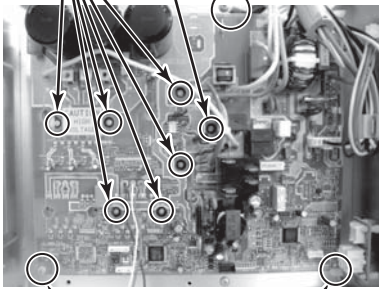
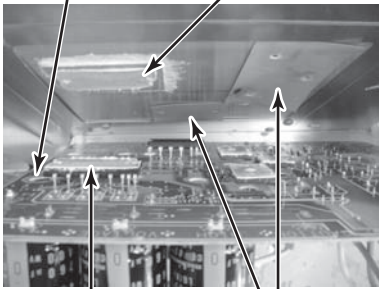

No.	Part name	Procedure	Remarks
⑥	DI P.C. board (Continued)	<p>7) Remove the earth wire of DI P.C. board. (Truss head B tight screw <math>\text{Ø}4 \times 6</math>, 1 pc.).</p> <p>8) Take off fixing screws for DI P.C. board. (Flange nut to fix element <math>\text{Ø}3 \times 16</math>, 7 pcs.: Pan head S tight screw to fix P.C. board <math>\text{Ø}3 \times 20</math>, 1 pc.)</p> <p>9) Remove DI P.C. board. (3 supporters)</p> <p><b>NOTE)</b></p> <hr/> <p>Be careful that DI P.C. board is difficult to be taken out by radiating grease for the heat sink.</p> <hr/> <p>10) Mount a new DI P.C. board.</p> <p><b>NOTE)</b></p> <hr/> <ul style="list-style-type: none"> <li>• Take note that the compressor lead V: CN201 (white) and the reactor lead CN05, CN06 are correctly attached. (For the compressor lead, the transparent sleeve is attached to the circular terminal, and for the reactor lead, the transparent sleeve is not attached to the circular terminal.)</li> <li>• Be sure not to forget to attach the Sub heat sink and also the radiating sheet. (If you apply a little amount of radiating grease beforehand to the rear side of the insulation sheet, the attaching work to the heat sink will become easy.)</li> </ul> <hr/>	<p>Fixing screws for element (7 positions)</p> <p>Earth screw</p>  <p>DI P.C. board fixing screw</p> <p>Supporters (3 positions)</p> <p>DI P.C. board</p> <p>Radiating grease</p>  <p>Sub heat sink</p> <p>Radiating sheet</p>

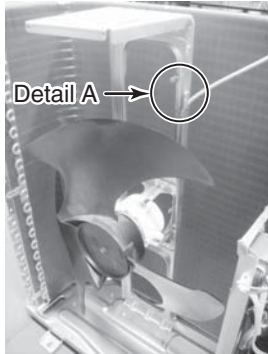
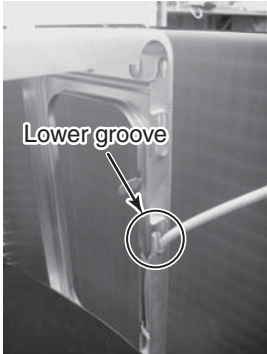
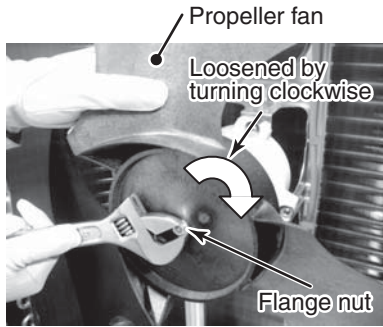
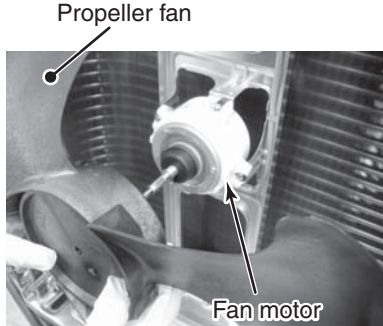
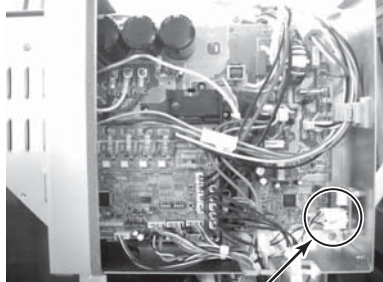
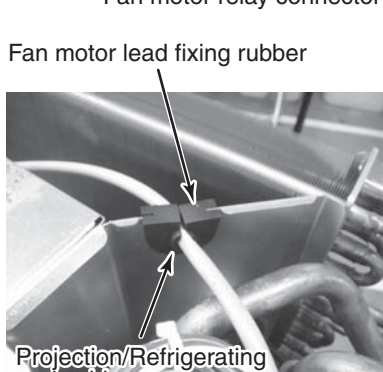
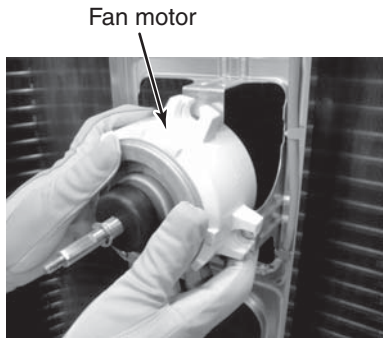



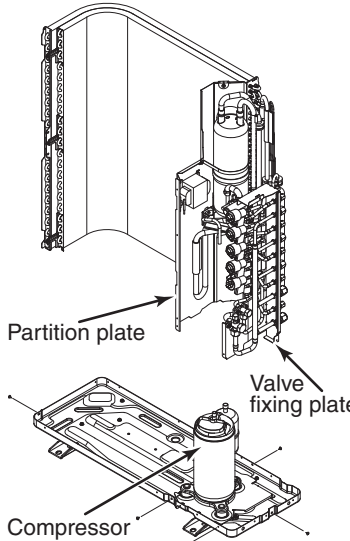
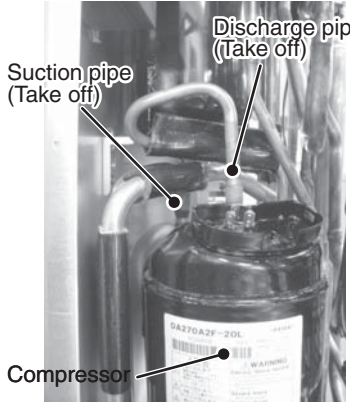

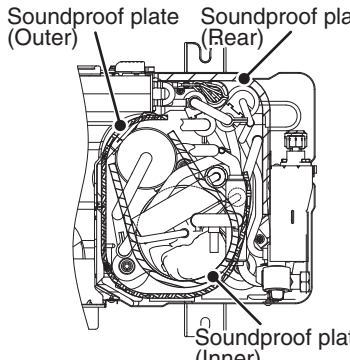
No.	Part name	Procedure	Remarks
⑧	Fan motor	<p>1) Perform works of Detachment 1 of ① and ② .</p> <p>2) Take off flange nut which fixes the fan motor and the propeller fan.  * The flange nut is loosened by turning it clockwise.  (To tighten the flange nut, turn it counterclockwise.)</p> <p>3) Remove the propeller fan.</p> <p>4) Remove the relay connector for fan motor from the inverter.</p> <p>5) Remove the fan motor lead from the fan motor lead fixing rubber of the penetrating part of the partition plate.</p> <p>6) Take off the fixing screws (4 pcs. each) while supporting the fan motor so that it does not fall.  * Caution to assembly of fan motor</p> <ul style="list-style-type: none"> <li>• Tighten the flange nut with 4.95N·m (50kgf·cm).</li> <li>• Adjust length of the fan motor lead fixing rubber so that the slackened fan motor lead does not come to contact with the propeller fan.</li> </ul> <p>Put in the fan motor lead fixing rubber to the partition plate so that the projection comes to the refrigerating cycle side.</p> <ul style="list-style-type: none"> <li>• <b>There provided at 2 positions the grooves to pass the fan motor lead wire into the motor base. Use the lower groove.</b></li> </ul> <div style="display: flex; justify-content: space-around; margin-top: 20px;"> <div data-bbox="395 1077 520 1104" style="text-align: center;"> <p>Motor base</p>  </div> <div data-bbox="699 1077 802 1104" style="text-align: center;"> <p>Detail A</p>  </div> </div> <div style="text-align: center; margin-top: 20px;"> <p><b>CAUTION</b></p> <hr/> <p>Using the metal band of the motor base, be sure to fix the fan motor lead to the motor base so that the fan motor lead does not come to contact with the propeller fan.</p> <hr/> </div>	<div style="margin-bottom: 10px;">  <p>Propeller fan Loosened by turning clockwise Flange nut</p> </div> <div style="margin-bottom: 10px;">  <p>Propeller fan Fan motor</p> </div> <div style="margin-bottom: 10px;">  <p>Fan motor relay connector</p> </div> <div style="margin-bottom: 10px;">  <p>Fan motor lead fixing rubber Projection/Refrigerating cycle side</p> </div> <div style="margin-bottom: 10px;">  <p>Fan motor</p> </div>

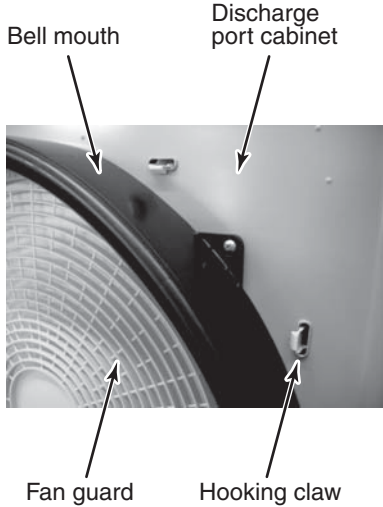
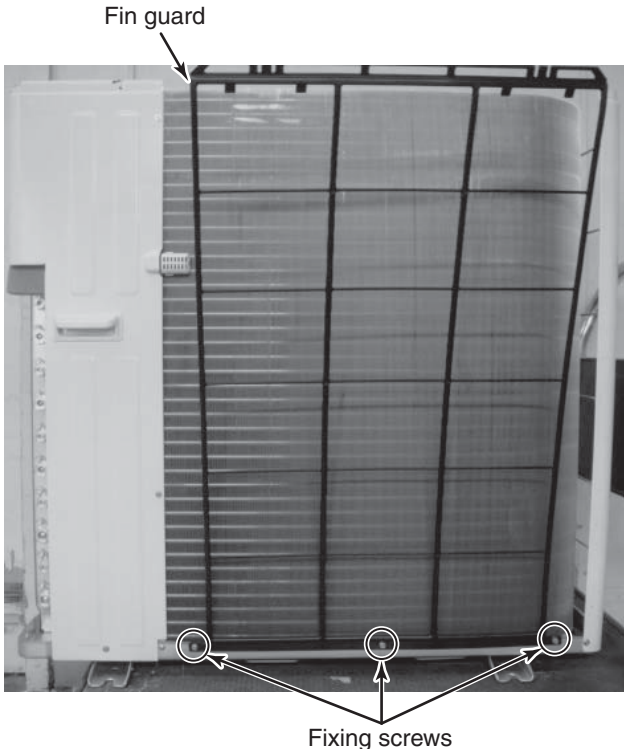

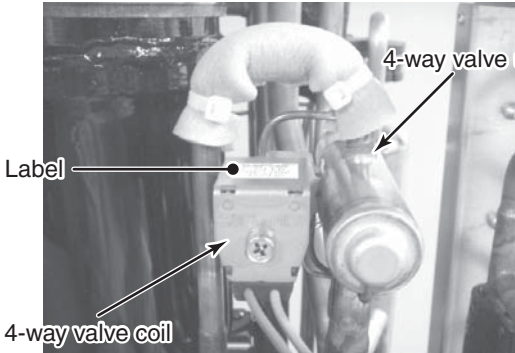
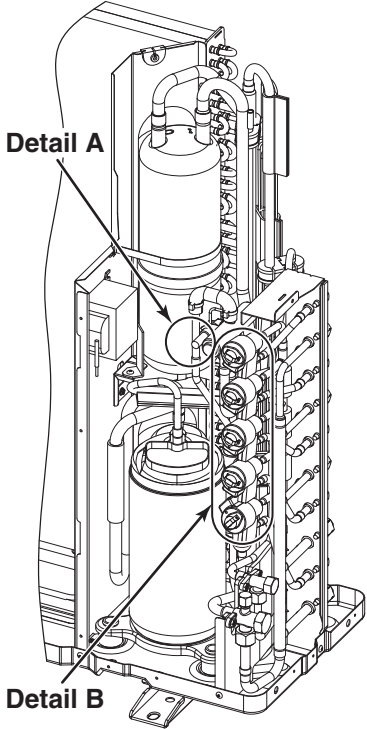
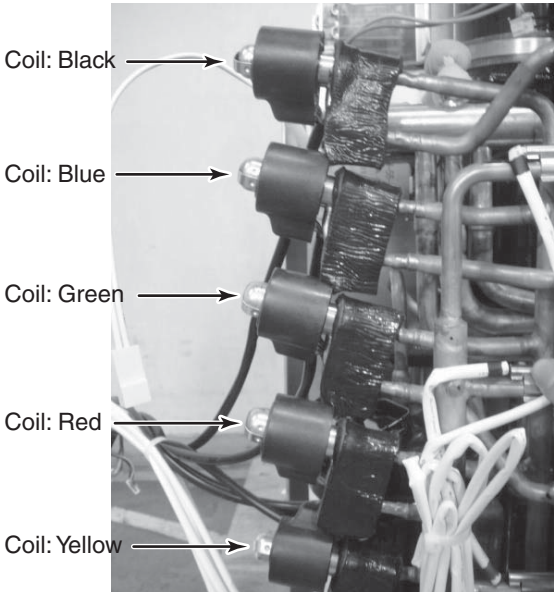
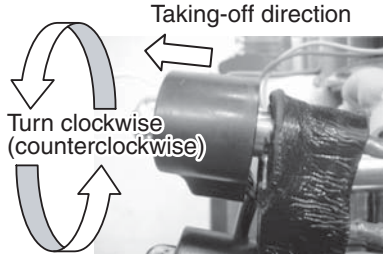
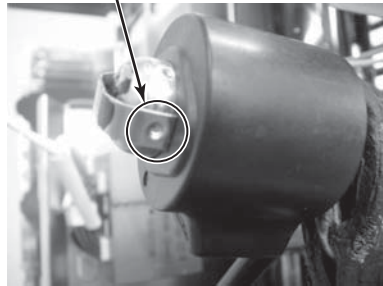
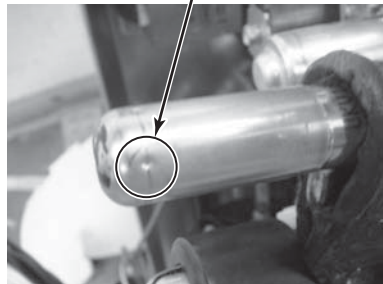
No.	Part name	Procedure	Remarks
⑨	Compressor assembly	<p><b>1. Removal of defective compressor</b></p> <ol style="list-style-type: none"> <li>1) Perform work of Detachment 1 of ① .</li> <li>2) Recover the refrigerant gas from the outdoor unit.</li> <li>3) Perform works of ② , ③ and ④ .</li> <li>4) Remove the soundproof plate and TD sensor.</li> <li>5) Take off fixing screw for the anchor board and the partition plate. (ST1T Ø4 × 8, 1 pc.)</li> <li>6) Take off fixing screws for the anchor board and the heat exchanger. (ST1T Ø4 × 8, 2 pcs.)</li> <li>7) Take off fixing screws for the anchor board and the valve fixing plate. (ST1T Ø4 × 8, 2 pcs.)</li> <li>8) Using a burner, remove the welded parts (discharge pipe, suction pipe) connected to the compressor.</li> </ol> <p><b>NOTE)</b></p> <hr/> <p>Take care that the electric parts, sensors, compressor, and etc. are not caught by flame. (Otherwise operation trouble may occur.)</p> <hr/> <p>9) Pull out the refrigerating cycle upward.</p> <p><b>NOTE)</b></p> <hr/> <p>Pull out the refrigerating cycle by two or more persons.</p> <hr/> <ol style="list-style-type: none"> <li>10) Take off the compressor bolts (3 pcs.) which fix the compressor to the compressor fixing plate.</li> <li>11) Remove the compressor from the compressor fixing plate.</li> </ol> <p><b>NOTE)</b></p> <hr/> <p>A compressor weighs approx. 15kg. Treat a compressor by two or more personals.</p> <hr/> <p>* Caution to assemble compressor</p> <ul style="list-style-type: none"> <li>• Tighten the compressor bolt with 5N•m (50kgf•cm).</li> <li>• Be sure not to burn lead wire of the coil.</li> <li>• Take care there is no missing of sensor.</li> </ul>	  <p>* Mount the soundproof plate by passing between the compressor and pipes and between pipes and the partition plate in order of upper, inner, outer and rear sides.</p>  

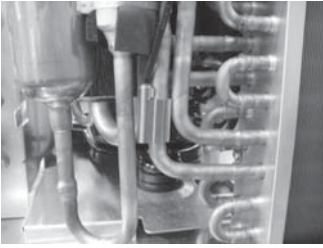
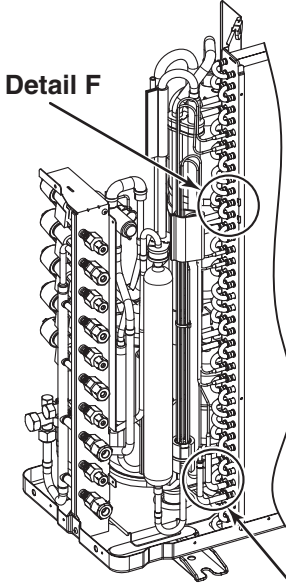
No.	Part name	Procedure	Remarks
⑩	Fan guard	<p><b>1. Detachment</b></p> <p>1) Perform works of Detachment 1 of ① and ② .</p> <p style="text-align: center;"><b>CAUTION</b></p> <hr/> <p>Work on the cardboard, cloth, and etc. in order to prevent damage on the product.</p> <hr/> <p>2) Take off the discharge port cabinet and put it as the fan guard side directs downward.</p> <p>3) Take off the hooking claws (8 positions) of the fan guard.</p> <p><b>2. Attachment</b></p> <p>1) Push the hooking claws (8 positions) with hands from the front side and then fix the claws.</p> <p style="text-align: center;"><b>CAUTION</b></p> <hr/> <p>Check all the hooking claws are fixed at each specified position.</p> <hr/>	 <p>The diagram shows a close-up of the fan guard assembly. It features a curved 'Bell mouth' at the top, a 'Discharge port cabinet' on the right, and the 'Fan guard' itself. 'Hooking claws' are shown as small metal protrusions on the fan guard that interlock with the discharge port cabinet.</p>
⑪	Fin guard	<p><b>1. Detachment</b></p> <p>1) Remove the top plate. (Hexagonal screw <math>\varnothing 4 \times 10</math>, 6 pcs.)</p> <p>2) Take off fixing screws for the fin guard and the anchor board. (Hexagonal screw <math>\varnothing 4 \times 10</math>, 3 pcs.)</p> <p>3) Mount a new fin guard.</p>  <p>The diagram shows a large fin guard assembly. It is a rectangular frame with horizontal slats. The 'Fin guard' label points to the top edge of the frame. 'Fixing screws' are indicated by three circles at the bottom of the frame, with arrows pointing to them.</p>	

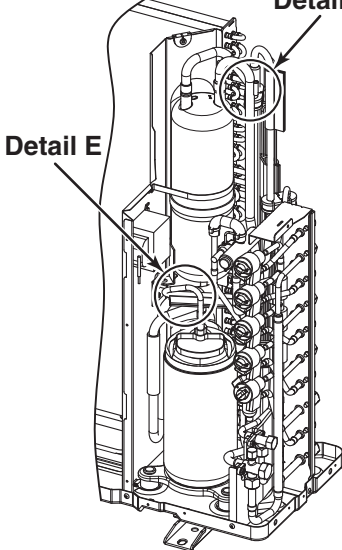
No.	Part name	Procedure	Remarks
⑫	4-way valve coil	<p>* <b>Attachment</b></p> <p>Mount 4-way valve coil so that the label side directs upper side of the cabinet.</p> <p><b>Detail A</b></p> 	
⑬	<p>PMV</p> <p>Coil: Black Coil: Blue Coil: Green Coil: Red Coil: Yellow</p>	<p><b>1. Detachment</b></p> <ol style="list-style-type: none"> <li>1) Perform work of Detachment 1 of ① .</li> <li>2) Turn the coil clockwise (counterclockwise) and then remove it from PMV main unit. (All 5 pcs.)</li> </ol> <p><b>2. Attachment</b></p> <ol style="list-style-type: none"> <li>1) Mount the PMV coil so that the coil lead wire taking-out part directs downward.</li> </ol> <p style="text-align: center;"><b>CAUTION</b></p> <hr/> <p>Coil: Mount yellow coil only so that lead wire taking-out part directs upward.</p> <hr/> <ol style="list-style-type: none"> <li>2) Match the positioning projection of coil with the concave part of PMV unit surely and fix it.</li> </ol> <p><b>Detail B</b></p> 	 <p>PMV sideways</p> <p>Projection of PMV coil</p>  <p>Concave part of PMV</p> 

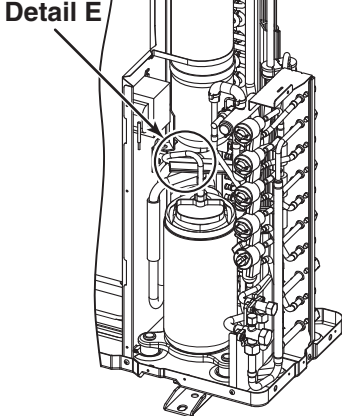
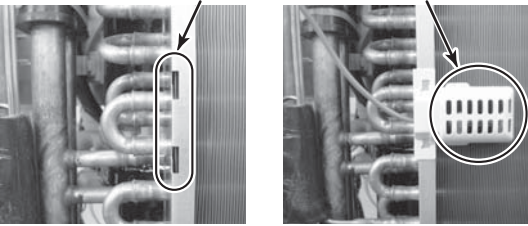
No.	Part name	Procedure	Remarks
⑭	TE sensor (Outdoor heat exchange temperature)	<p>* <b>Attachment</b></p> <p>Mount TE sensor on the straight part of the condenser discharge port pipe so that the lead wire directs upward and the sensor directs the liquid store tank.</p> <p><b>Detail C</b></p> 	 <p><b>Detail F</b></p>
⑮	TS sensor (Suction temperature)	<p>* <b>Attachment</b></p> <p>Insert TS sensor into the sensor holder welded to the suction pipe and then mount it.</p> <p><b>Detail D</b></p> 	 <p><b>Detail C</b> <b>Detail D</b></p>
⑯	TD sensor (Discharge temperature)	<p>* <b>Attachment</b></p> <p>Mount TD sensor on the straight part of the discharge pipe so that the lead wire directs upward and the sensor directs upward of the cabinet.</p> <p><b>Detail E</b></p> 	 <p><b>Detail E</b></p>
⑰	TO sensor (Outside temperature)	<p>* <b>Attachment</b></p> <p>Insert TO sensor holder claw into the heat exchange terminal block hole and then mount it.</p> <p><b>Detail F</b></p> <p>Heat exchange terminal block hole      TO sensor holder</p> 	<p><b>NOTE</b></p> <hr/> <p>At working time (finish time), be sure not to damage the cover of the sensor lead wire with edge of sheet metal, etc.</p> <p>If the cover of the sensor lead wire is damaged, it is dangerous because an electric shock or fire may be caused.</p> <hr/> <p><b>NOTE</b></p> <hr/> <p>After replacing of parts, check the sensors are mounted at the specified positions.</p> <p>If there are incorrect mounted positions, control of the product does not operate correctly and a trouble may be caused.</p> <hr/>

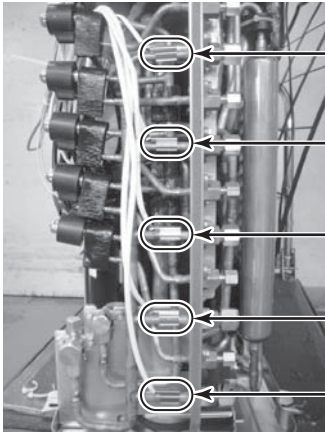
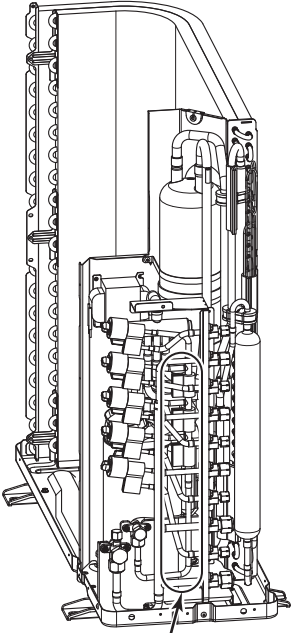
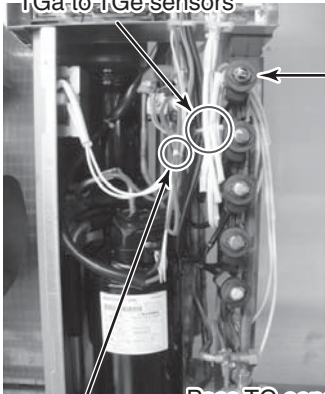

No.	Part name	Procedure	Remarks
⑱	TG sensor TGe: Black TGd: Blue TGc: Green TGb: Red TGa: Yellow	<p><b>* Attachment</b></p> <p>Mount these sensors on the directly arranged part of the header connecting pipe at gas side so that the cabinet turns toward the front side and the sensors turn toward upper cabinet.</p> <p><b>NOTE)</b></p> <hr/> <p>When mounting the sensors, check paint color of the sensor lead tube part and the pipe color. Mount the sensors to the position of same color.</p> <hr/> <p><b>Detail G</b></p>  <p>TGe: Black            TGd: Blue            TGc: Green            TGb: Red            TGa: Yellow</p>	 <p><b>Detail G</b></p> <p><b>NOTE)</b></p> <hr/> <p>At working time (finish time), be sure not to damage the cover of the sensor lead wire with edge of sheet metal, etc.</p> <p>If the cover of the sensor lead wire is damaged, it is dangerous because an electric shock or fire may be caused.</p> <hr/> <p><b>NOTE)</b></p> <hr/> <p>After replacing of parts, check the sensors are mounted at the specified positions.</p> <p>If there are incorrect mounted positions, control of the product does not operate correctly and a trouble may be caused.</p> <hr/>
⑲	Sensor wiring process	<ul style="list-style-type: none"> <li>Using bundling band, bind PMV coil (Black to Yellow) with Tga to Tge.</li> <li>For Td sensor, bind the case thermo and reactor lead by bundling band.</li> </ul> <p>Bundling band            PMV coil (Black to Yellow)            TGa to TGe sensors</p>  <p>Pass TG sensor through the upper side of connecting pipe of PMV unit (Black) and then bind it with lead wire of PMV coil.</p> <p>Bundling band            Td sensor            Case thermo            Reactor lead</p> <p><b>NOTE)</b></p> <hr/> <p>Using the bundling band being on the market, be sure to bind the position which was bound.</p> <hr/>	<p><b>NOTE)</b></p> <hr/> <p>At working time (finish time), be sure not to damage the cover of the sensor lead wire with edge of sheet metal, etc.</p> <p>If the cover of the sensor lead wire is damaged, it is dangerous because an electric shock or fire may be caused.</p> <hr/> <p><b>NOTE)</b></p> <hr/> <p>After replacing of parts, check the sensors are mounted at the specified positions.</p> <p>If there are incorrect mounted positions, control of the product does not operate correctly and a trouble may be caused.</p> <hr/>

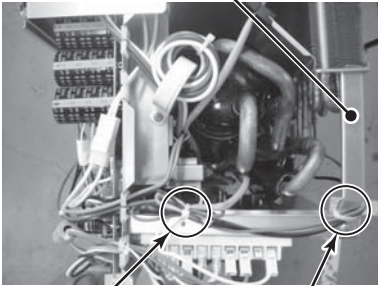
No.	Part name	Procedure	Remarks
⑰	Sensor wiring process (Continued)	<ul style="list-style-type: none"> <li>* Bind TS sensor, TE sensor and TO sensor with the bundling band.</li> <li>* Pass TE sensor and TO sensor through upper part of the inverter fixing board and then bind them with the bundling band.</li> </ul> <p><b>NOTE)</b></p> <hr/> <p>Using the bundling band being on the market, be sure to bind the position which was bound.</p> <hr/>	 <p style="text-align: center;">Inverter fixing board</p> <div style="display: flex; justify-content: space-around; margin-top: 20px;"> <div style="text-align: center;"> <p>Bundling band TS sensor TE sensor TO sensor</p> </div> <div style="text-align: center;"> <p>Bundling band TE sensor TO sensor</p> </div> </div>

## 13. EXPLODED VIEWS AND PARTS LIST

### 13-1. Indoor Unit

**RAS-M10PKVP-E, RAS-M13PKVP-E, RAS-M16PKVP-E, RAS-M18PKVP-E**

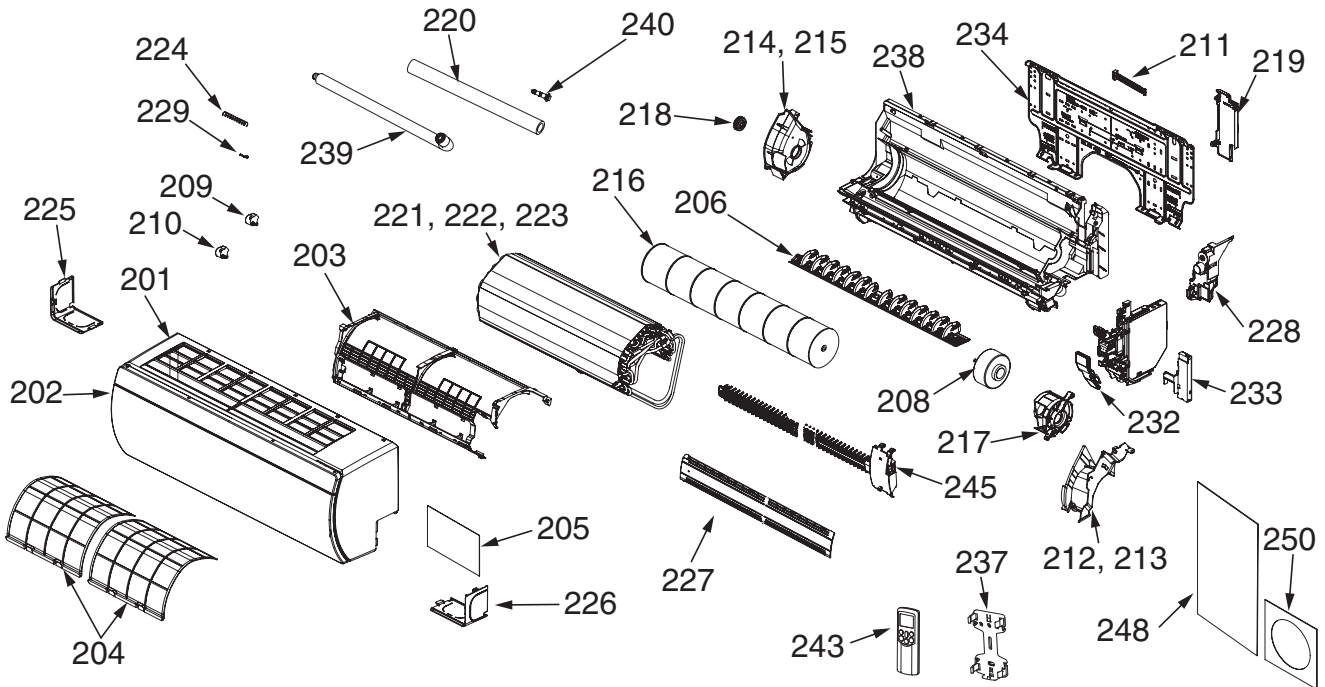

\* The parts in the following parts list are conformed to RoHS.  
Therefore be sure to use the following parts for repairing and replacing.

Location No.	Part No.	Description
201	43005779	Panel Ass'y
202	43005778	Frame, Airl Ass'y
203	4301V098	Fix, Frame Ass'y
204	43080609	Filter, Air
205	4308S232	Wiring Diagram
206	43022455	Louver Ass'y
208	4302C095	Fan Motor Ass'y
209	4302C076	Motor, Louver (For Panel)
210	4302D003	Motor, Louver (For Louver)
211	4306A172	Cord, Motor, Louver
212	4301V103	Cover Ass'y, Motor (M18)
213	4301V104	Cover Ass'y, Motor (M10, 13, 16)
214	43022458	Base, Bearing Ass'y (M18)
215	43022459	Base, Bearing Ass'y (M10, 13, 16)
216	43020372	Fan Ass'y, Cross Flow
217	43039376	Band, Motor, Right
218	43125171	Bearing Ass'y, Mold
219	4301V083	Holder, Pipe
220	43049787	Pipe, Shield
221	43044870	Refrigeration Cycle Ass'y (M10,13)

Location No.	Part No.	Description
222	43044876	Refrigeration Cycle Ass'y (M16)
223	43044875	Refrigeration Cycle Ass'y (M18)
224	43049784	Spring
225	43096255	Panel, Bush (L)
226	43096257	Panel, Bush (R)
227	4301V097	Guard, Plasma Pure Filter
228	4301V089	Base Ass'y, Motor
229	43019904	Holder, Sensor
232	43062276	Connector, Cover Ass'y
233	43062275	Lead, Cover Ass'y
234	43082296	Plate, Installation
237	43083071	Holder, Remote Controller
238	43003323	Body Ass'y, Back
239	43070199	Hose, Drain
240	43079239	Cap, Drain
243	43066024	Remote Controller Wireless
245	43080608	Plasma Pure Filter Ass'y
248	4308S213	Owner's Manual (M10, 13, 16, 18PKVP-E)
250	4308S217	Owner's Manual (CD-ROM)



## 13-2. Microcomputer P.C. Board

RAS-M10PKVP-E, RAS-M13PKVP-E, RAS-M16PKVP-E, RAS-M18PKVP-E

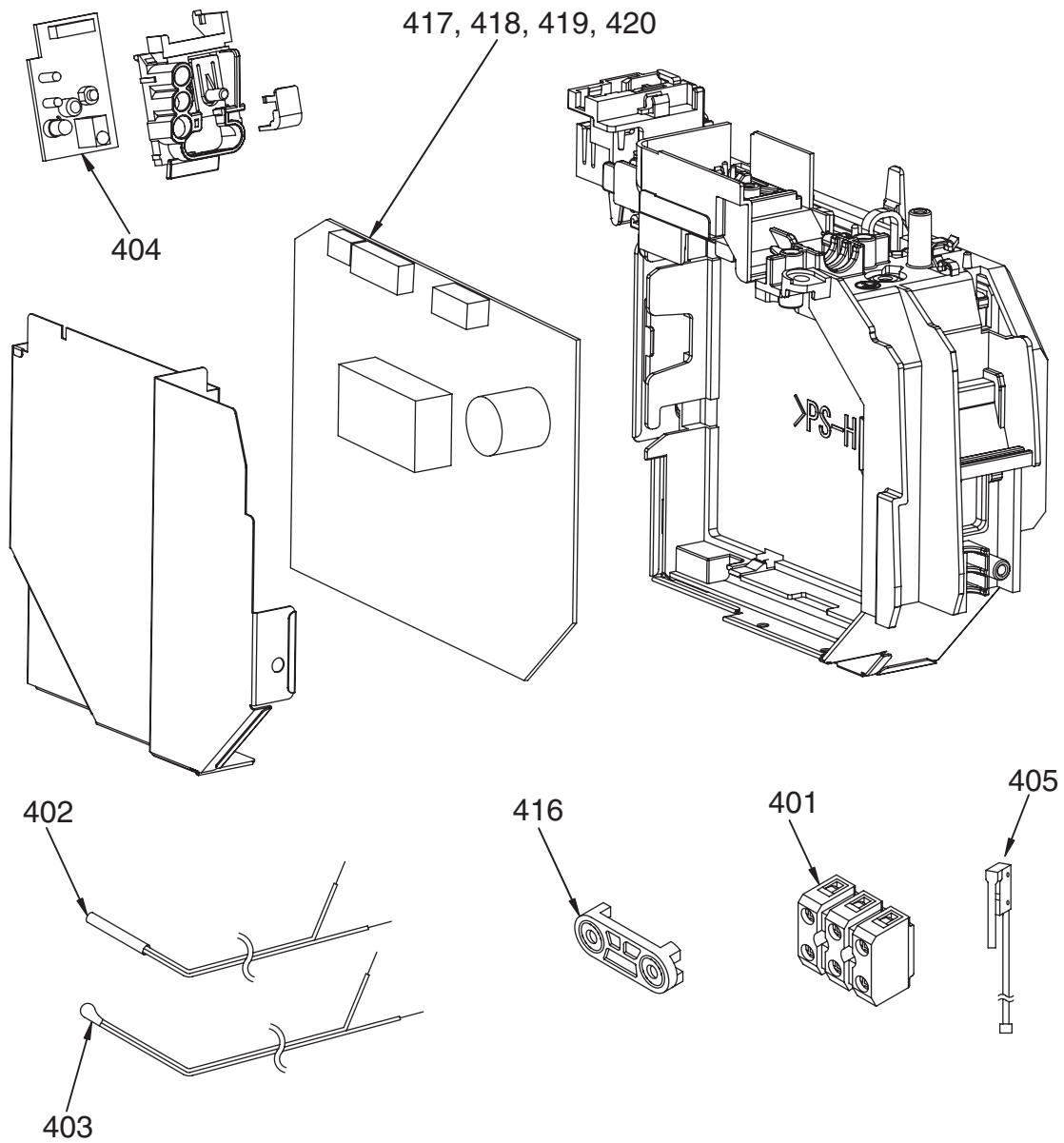

\* The parts in the following parts list are conformed to RoHS.  
Therefore be sure to use the following parts for repairing and replacing.

Location No.	Part No.	Description
401	4306A132	Terminal Block, 3P
402	43050425	Sensor Ass'y, Service
403	43050426	Sensor, Service
404	4306V137	P.C. board Ass'y, WRS-LED
405	43051349	Switch Ass'y Micro
416	43067115	Clamp, Cord

Location No.	Part No.	Description
417	4306V206	P.C. board Ass'y, M10PKVP-E
418	4306V207	P.C. board Ass'y, M13PKVP-E
419	4306V208	P.C. board Ass'y, M16PKVP-E
420	4306V209	P.C. board Ass'y, M18PKVP-E



\* The parts in the following parts list are conformed to RoHS.  
Therefore be sure to use the following parts for repairing and replacing.

Location No.	Part No.	Description
1	43005793	Cabinet, Back Ass'y
2	43005792	Cabinet, Front Ass'y
3	43100440	Plate, Roof
4	43100453	Panel, Air Outlet
5	43107278	Guard, Fin, Side
6	43107277	Guard, Fin, Back
7	43109422	Guard, Fan
8	43122113	Bell Mouth
9	43100455	Base Ass'y
10	4304C702	Compressor, DA270A2F-20L
12	43146686	Valve, Packed, 9.52
13	43046508	Valve, Packed, 12.7
14	43047684	Socket, 6.35 DIA
15	43047683	Socket, 9.52 DIA
16	43047682	Socket, 12.7 DIA
17	43147196	Bonnet, 1/4 IN
18	43047401	Bonnet, 3/8 IN
19	43147195	Bonnet, 1/2 IN
20	43047685	Nut, Flare, 1/4 IN
21	43047686	Nut, Flare, 3/8 IN
22	43047688	Nut, Flare, 1/2, IN
23	43046449	Body, PMV
24	4314N025	Coil, PMV, UKV-A038

Location No.	Part No.	Description
25	43163055	Holder, Sensor
28	43050407	Thermostat, Bimetal
29	43063317	Holder, Thermostat
30	43049739	Cushion, Rubber
31	43122120	Supporter, Motor
32	43047669	Nut, Flange
33	43120244	Fan, Propeller, PB521
34	4312C037	Motor, Fan, ICF-280-A100-1
35	43058290	Reactor, CH-56-2FC
36	43148170	Accumulator Ass'y
39	43046500	Valve, 4-way, STF-H0218
40	43046502	Coil, Solenoid, VHV-H01AP1768A1
42	43043808	Condenser Ass'y
43	43032441	Nipple, Drain
46	43047674	Cap, Charge, Port
47	43047680	Cap, Valve, Packed, 9.52
48	43049790	Cap, Valve, Packed, 12.7
49	43063320	Holder, Sensor, 9.52, TE, TG
50	43063321	Holder, Sensor, 9.52, TD
51	43063322	Holder, Sensor, 12.7, TG
52	43019904	Holder, Sensor
53	43196113	Bushing
54	4301L506	Mark, TOSHIBA, IMS

**No. 24 Coil, P.M.V. :** For standardization of the servicing parts, one type only is provided.  
Therefore, color of the connector may be different in replacement work.

## 13-4. Inverter Assembly

RAS-5M34UAV-E

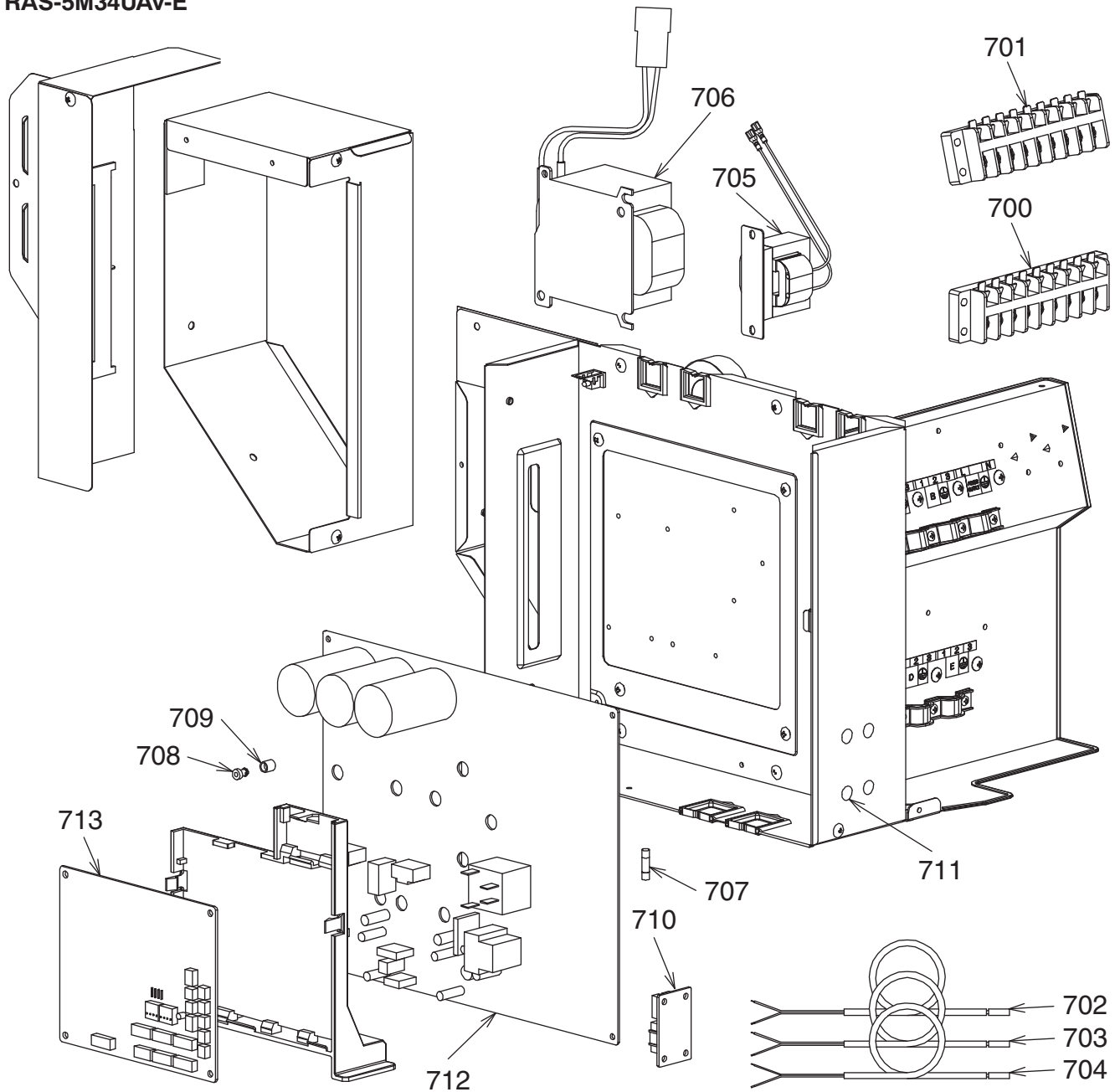

\* The parts in the following parts list are conformed to RoHS.  
Therefore be sure to use the following parts for repairing and replacing.

Location No.	Part No.	Description
700	43160610	Terminal Block, 9P (A)
701	43160611	Terminal Block, 9P (B)
702	43050425	Sensor Ass'y, Service (TO, TE, TS)
703	43050446	Sensor Ass'y, Service (TGa to TGe)
704	43150319	Sensor Ass'y, Service (TD)
705	43158192	Reactor

Location No.	Part No.	Description
706	43155188	Reactor, CH-56-2Z-T
707	43160589	Fuse
708	43163059	Spacer, Bush
709	43163060	Spacer, Collar
710	4316V393	P.C. board Ass'y, MCC-1436
711	43163062	Spacer Ass'y
712	4316V414	P.C. board Ass'y, MCC-1571
713	4316V415	P.C. board Ass'y, MCC-5071

# **TOSHIBA CARRIER CORPORATION**

23-17, TAKANAWA 3 CHOME, MINATOKU, TOKYO, 108-8580, JAPAN

Copyright © 1999 to 2009 TOSHIBA CARRIER CORPORATION, ALL Rights Reserved.