

AxZent – Thermo centrifugal fan

Installation and Operating Instructions

GB

Document in original language | · 004

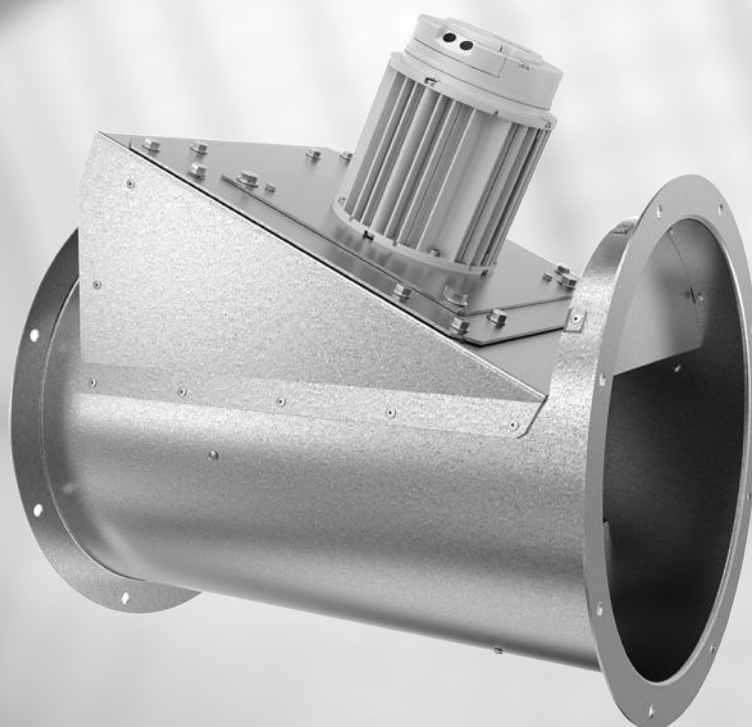

© Copyright Systemair AB
All rights reserved
E&OE

Systemair AB reserves the rights to alter their products without notice.
This also applies to products already ordered, as long as it does not affect the previously agreed specifications.

Contents

1	General information	1
1.1	Notice symbols	1
1.1.1	Instruction symbols	1
2	Important safety information	1
2.1	Personnel	1
2.2	Personal protective equipment	2
2.3	5 rules of electrical safety	2
3	Warranty	2
4	Delivery, transport, storage	2
5	Description	3
5.1	Intended use	3
5.2	Incorrect use	3
5.3	Technical data	3
5.4	Air flow direction	4
5.5	Dimensions	4
6	Name plate and type key	5
7	Accessories	6
8	Installation	6
8.1	Installation positions	7
8.2	Assembly/Disassembly impeller – Internal rotor motor	7
9	Electrical connection	9
9.1	Electrical connection accessories	9
9.2	Protecting the motor	10
9.3	Variable-speed fans	11
10	Commissioning	11
11	Operation	11
12	Troubleshooting/maintenance/repair	12
12.1	Troubleshooting	12
12.2	Maintenance	13
13	Cleaning	14
14	Deinstallation/dismantling	14
15	Disposal	14
16	EU Declaration of conformity	15
17	Commissioning Report	16

1 General information

1.1 Notice symbols



Danger

Direct hazard

Failure to comply with this warning will lead directly to death or to serious injury.



Caution

Hazard with a low risk

Failure to comply with this warning may lead to moderate injuries.



Warning

Potential hazard

Failure to comply with this warning may lead to death or serious injury.

Important

Hazard with risk of damage to objects

Failure to comply with this warning will lead to damage to objects.



Note:

Useful information and instructions

1.1.1 Instruction symbols

Instruction

- ◆ Carry out this action
- ◆ (if applicable, further actions)

Instruction with fixed sequence

1. Carry out this action
2. Carry out this action
3. (if applicable, further actions)

2 Important safety information

Planners, plant builders and operators are responsible for the proper assembly and intended use.

- ◆ Read the operating instructions completely and carefully.
- ◆ Keep the operating instructions and other valid documents, such as the circuit diagram or motor instructions, with the fan. They must always be available at the place of use.
- ◆ Observe and respect local conditions, regulations and laws.
- ◆ Abide by the system-related conditions and requirements of the system manufacturer or plant constructor.
- ◆ Safety elements may not be dismantled, circumvented or deactivated.
- ◆ Only use the fan in a flawless condition.
- ◆ Provide generally prescribed electrical and mechanical protective devices.
- ◆ During installation, electrical connection, commissioning, troubleshooting, and maintenance, secure the location and premises against unauthorised access.
- ◆ Do not circumvent any safety components or put them out of action.
- ◆ Before any work on the fan, test absence of voltage.
Even when the motor is stopped, dangerous voltages may be present on terminals.
- ◆ Keep all the warning signs on the fan complete and in a legible condition.
- ◆ The device is not to be used by persons (including children) with reduced physical, sensory or mental capabilities, or lack of experience and knowledge, unless they have been given supervision or instruction.
- ◆ Do not allow children to play with the device.

2.1 Personnel

The fan may only be used by qualified, instructed and trained personnel. The persons must know the relevant safety directives in order to recognise and to avoid risks. The individual activities and qualifications can be found in Table 1 *Qualifications*, page 2.

Table 1 Qualifications

Activities	Qualifications	
Storage, operation, transport, cleaning, disposal	Trained personnel (see following note)	
Electrical connection, commissioning, electrical disconnection	Electrical expert or matching qualification	
Installation, disassembly	Fitter or matching qualification	
Maintenance	Electrical expert or matching qualification	Fitter or matching qualification
Repair	Electrical expert or matching qualification	Fitter or matching qualification
	Smoke extraction fans and EX fans only by agreement with Systemair.	

**Note:**

The operator is responsible for ensuring that personnel are instructed and have understood the contents of the operating instructions. If something is unclear, please contact Systemair or its representative.

2.2 Personal protective equipment

◆ Wear protective equipment during all work in the vicinity of the fan.

- protective working clothes
- protective working gloves
- goggles
- protective working shoes
- helmet
- hearing protection

2.3 5 rules of electrical safety

1. Disconnect (disconnection of the electrical system from live components at all terminals)
2. Prevent reactivation
3. Test absence of voltage
4. Ground and short-circuit
5. Cover or restrict adjacent live parts

3 Warranty

For the assertion of warranty claims, the products must be correctly connected and operated, and used in accordance with the data sheets. Further prerequisites are a completed maintenance plan with no gaps and a commissioning report. Systemair will require these in the case of a warranty claim. The commissioning report is a component of this document. The maintenance plan must be created by the operator, see section 12.2 *Maintenance*, page 13.

4 Delivery, transport, storage

Safety information

Warning: Risk from rotating fan blades

◆ Prevent access by unauthorised persons by safety personnel or access protection.

Warning: Suspended loads

- ◆ Do not walk under suspended loads.
- ◆ Make sure that there is nobody under a suspended load.

Delivery

Each fan leaves our plant in an electrically and mechanically proper condition. We recommend transporting the fan to the installation site in the original packaging.

Checking delivery

- ◆ Check the packaging and the fan for transport damage. Any findings should be noted on the cargo manifest.
- ◆ Check completeness of the delivery.

Unpacking

When opening the transport packaging, there is a risk of damage from sharp edges, nails, staples, splinters etc.

- ◆ Unpack the fan carefully.
- ◆ Check the fan for obvious transport damage.
- ◆ Only remove the packaging shortly before assembly.

Transport

Safety information

Warning: Electrical or mechanical hazards due to fire, moisture, short circuit or malfunction.

- ◆ Never transport the fan by the connecting wire, terminal box, impeller, protection grille, inlet cone or silencer.
- ◆ In open transport, please make sure that no water can penetrate into the motor or other sensitive parts.
- ◆ We recommend transporting the fan to the installation site in the original packaging.

Caution: If transported without care during loading and unloading, the fan may be damaged.

- ◆ Load and unload the fan carefully.
- ◆ Use hoisting equipment that is suitable for the weight to be hoisted.
- ◆ Observe the transportation arrows on the packaging.
- ◆ Use the fan packaging exclusively as transport protection and not as a lifting aid.

Storage

- ◆ Store the fan in the original packaging in a dry, dust-free location protected against weather.
- ◆ Avoid the effects of extreme heat or cold.

Hazard due to loss of function of the motor bearing

- ◆ Avoid storing for too long (recommendation: max. 1 year).
- ◆ Check that the motor bearing functions properly before installation.

5 Description

5.1 Intended use

- The fans are intended for installation in ventilation systems. They can be installed both in duct systems and also with free suction via an inlet cone and a suction-side contact protection grille. Free discharge via a contact protection grille is also possible.
- The fan is suitable for conveying contaminated air.

5.2 Incorrect use

Incorrect use refers mainly to using the fan in another way to that described. The following examples are incorrect and hazardous:

- Conveying of explosive and combustible media
- Conveying of aggressive media
- Operation in an explosive atmosphere
- Operation without duct system or protection grille
- Operation with the air connections closed
- Installation outside without weather protection

5.3 Technical data

Max. ambient temperature [°C]	see data sheet, available in our online catalogue.
Max. temperature of transported air [°C]	120
Sound pressure [dB]	see data sheet, available in our online catalogue.
Voltage, current, frequency, enclosure class, weight	see name plate of the fan

The motor data can be found on the name plate of the motor, or in the technical documents of the motor manufacturer.

The data on the name plate of the fan apply to "standard air" according to ISO 5801.

5.4 Air flow direction

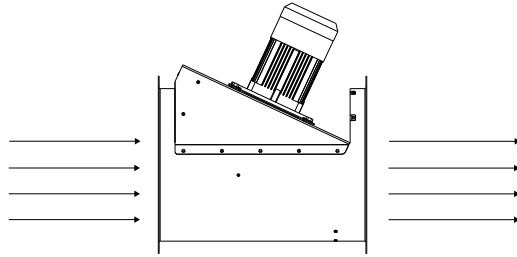

5.5 Dimensions

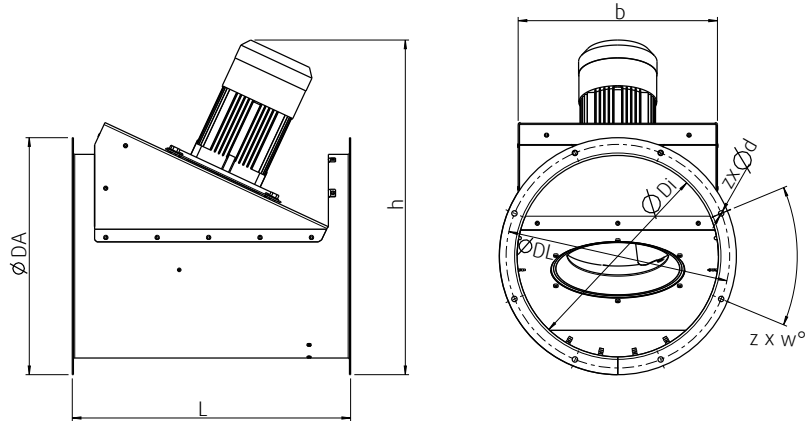



Table 2 Dimensions AxZent [mm]



Size	L	ØDa	b	ØDi	ØDL	z x w	z x Ød
400	585.7	480	391.7	400.5	450	8 x 45°	8 x Ø12
450	622.5	530	445.7	450.5	500.4	8 x 45°	8 x Ø12
500	720	590	495.7	500.5	560	12 x 30°	12 x Ø12
560	795	650	558	560.5	620	12 x 30°	12 x Ø12
630	825	720	629,7	630.5	690	12 x 30°	12 x Ø12

Table 3 Axzent Measurement h

400	D2: 722.5 mm / DV: 637.5 mm / E4: 653.80 mm / EC: 635 mm	560	D4: 808.4 mm / E4: 815 mm / EC: 795 mm
450	D2: 748.4 mm / DV: 662.9 mm / E4: 679.2 mm / EC: 660 mm	630	D4: 898mm / E4: 898 mm / EC: 899 mm
500	DV: 727.7 mm / E4: 7442 mm / EC: 746 mm		

6 Name plate and type key

1 —	AxZent 400EC								
2 —	230 V~	0,78 A		50 Hz					
3 —			183 W						
4 —	tF=120°C								
5 —	IP55	1510 min ⁻¹		34,5kg					
6 —	INS.CL.B								
7 —	Serial.no: 37748/1003338357-001/20171120								



8

Made in GERMANY

- | | | | |
|---|-------------------------------------|---|---|
| 1 | Type designation | 5 | Enclosure class/fan impeller speed/weight |
| 2 | Voltage/current/frequency | 6 | Insulation class |
| 3 | Input power | 7 | Article number/production number/manufacturing date |
| 4 | Max. temperature of transported air | 8 | Certifications |

Table 4 Type key

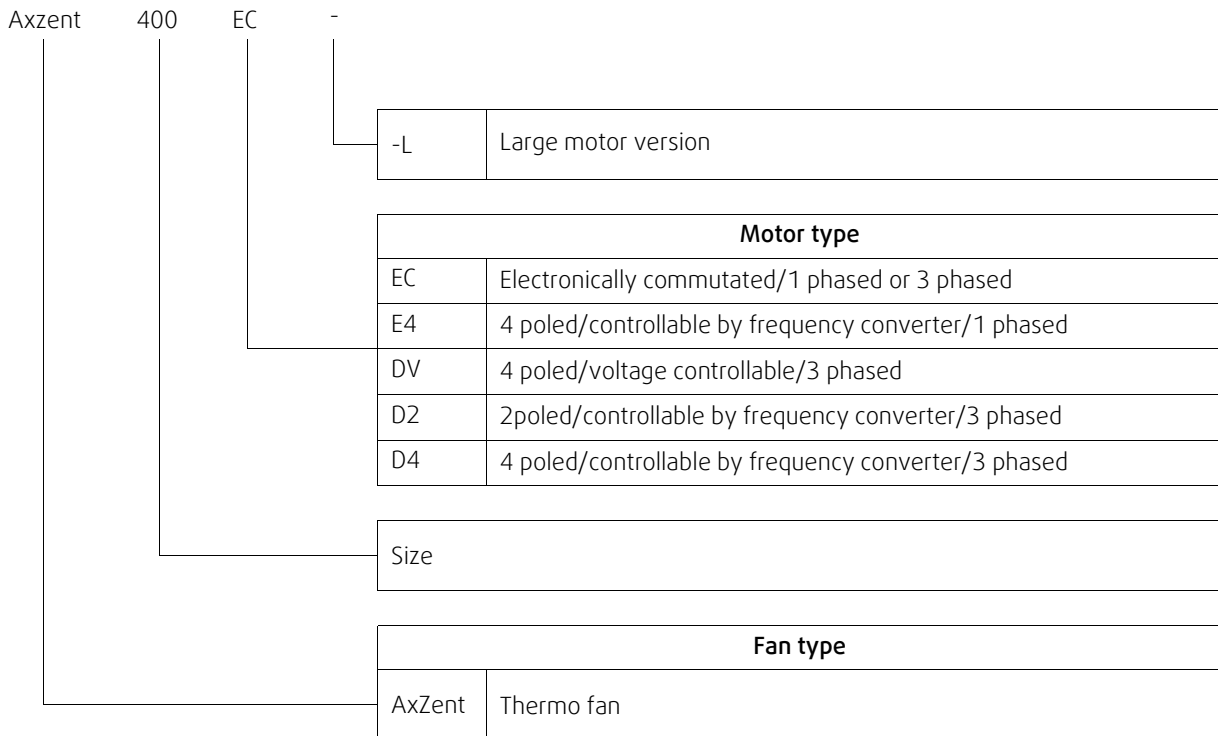

7 Accessories



Note:

For details of the accessories, please check our online catalog or contact Systemair.

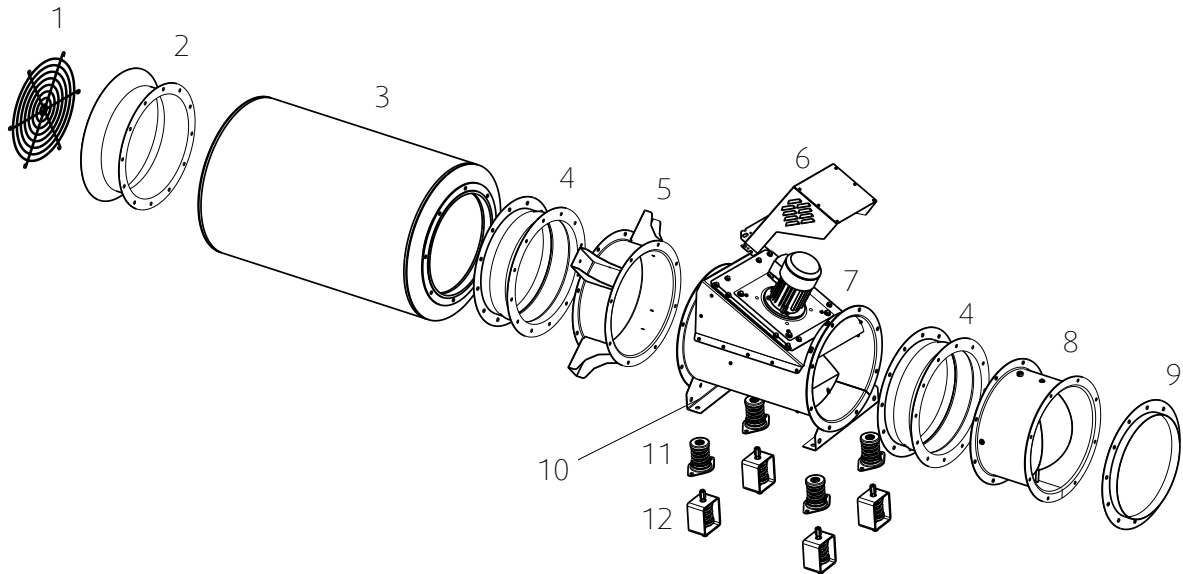

Table 5 Accessories

1	SG	Protection guard	7	AxZent	Fan
2	ESD-F	Inlet cone	8	LRK	Air operated damper
3	RSA	Silencer	9	GFL	Counter flange
4	EVH	Flexible connection	10	MFA	Mounting foot
5	MPR	Mounting ring	11	FSD	Spring anti-vibration mounts
6	WSD	Weather protection roof	12	ZSD	Suspension spring anti-vibration mounts

8 Installation

Safety information

- ◆ Observe 2 *Important safety information*, page 1
- ◆ Use installation material with fire resistance classes that meet temperature requirements.
- ◆ Provide contact and intake protection and ensure safety distances according to DIN EN ISO13857 and DIN 24167-1.
- ◆ To reduce transmission of vibration to the duct system, we recommend flexible connections from our accessory range, see chapter Accessories.

Preconditions

- ◆ Ensure that the fan and all its components are undamaged.
- ◆ Fit the fans in such a way that there is sufficient access for installation, troubleshooting, maintenance and repair.
- ◆ Protect against dust and moisture when installing.
- ◆ Ensure that the information on the name plates (fan and motor) matches up with the operating conditions.

Important**Damage to the bearings or other parts of the fan can occur.**

- ◆ Do not place a duct bend directly before or after the fan!
- ◆ Ensure a smooth and constant air flow to the device.

Important**Damage to the bearings or other parts of the fan can occur.**

- ◆ Do not place a duct bend directly before or after the fan!
- ◆ Ensure a smooth and constant air flow to the device.

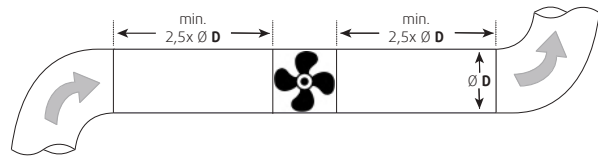

- Round duct system: **D** = Nominal diameter
- Rectangular duct system: **D** = Hydraulic diameter

8.1 Installation positions**Important****Dirt deposits**

- ◆ In order to avoid dirt deposits in the fan, the motor must not be oriented downwards. Therefore, the installation positions as shown in the adjacent image have to be avoided.

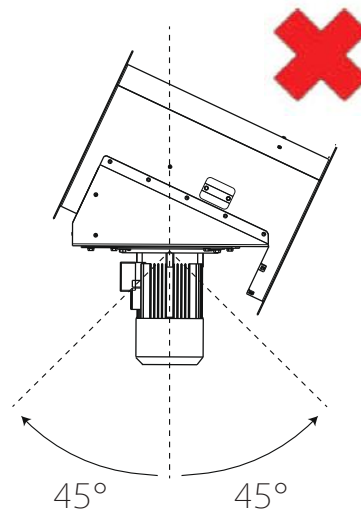
**8.2 Assembly/Disassembly impeller – Internal rotor motor**

If an external rotor motor is used, the motor and impeller can't be separated.

Important**Damage to the motor and impeller.**

The ball bearing of the motor and the balanced impeller may be damaged by forceful impacts.

- ◆ Attach the impeller and/or the shaft extension to the shaft or the rotor without forceful impacts.
- ◆ **Do not separate the impeller and the hub. They were balanced as one unit by Systemair.**

**Note:**

The hub can be heated for easier assembly and disassembly, for example with a hot-air blower.

- Precondition for assembly: the wedge is in the intended groove.
- Tools: hexagon socket wrench and suitable tool for removal, torque wrench for the taper clamping bush.

- 1 Motor
- 2 Motor shaft
- 3 Sleeve (not available at every fan)
- 4 Shaft extension (not available at every fan)
- 5 Hexagon socket screw
- 6 Impeller
- 7 Steel hub
- 8 Aluminium hub

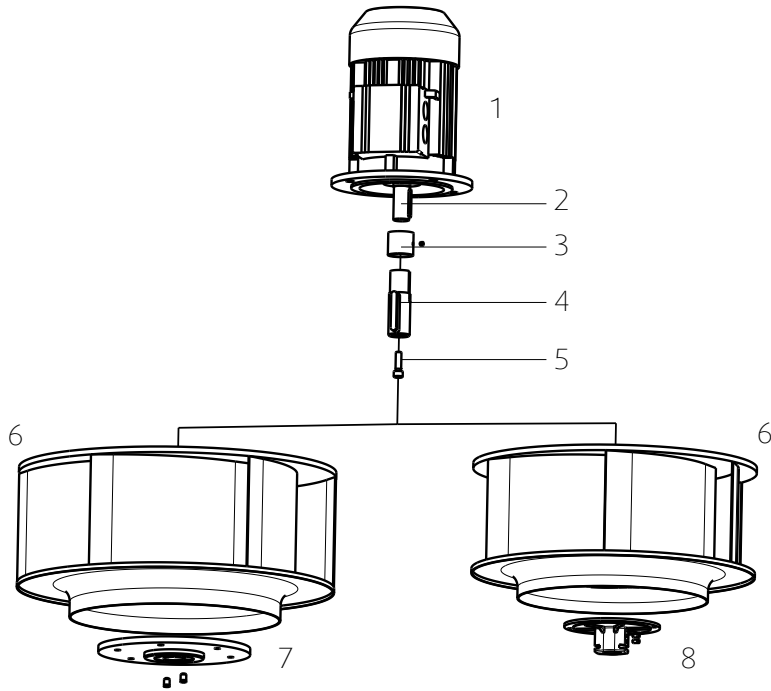

The hub is shown without impeller due to better lucidity.

Disassembly

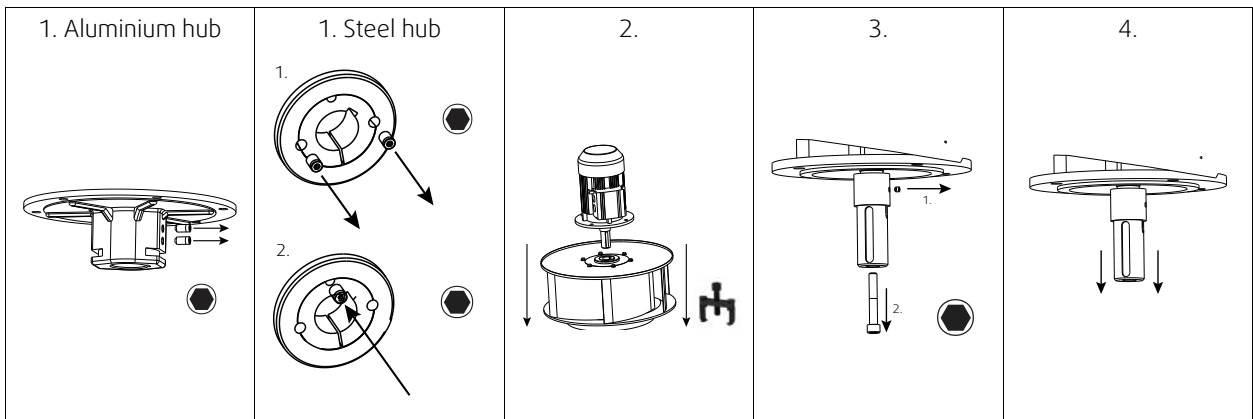

Assembly

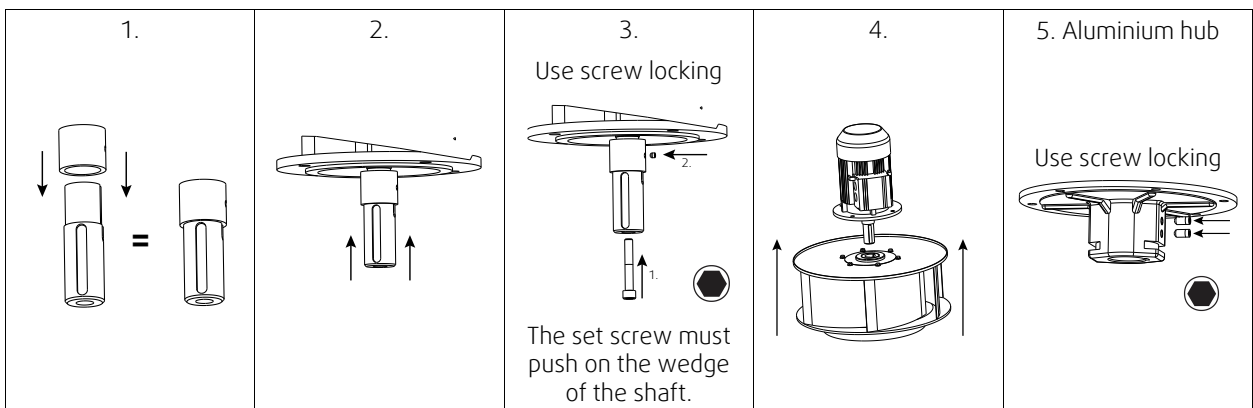

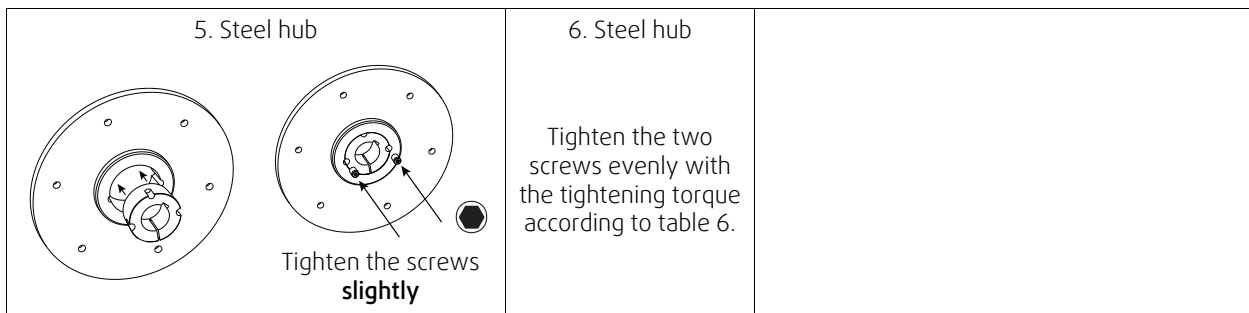
**Table 6 Tightening torques for various types of bush**

Type of bush	1008	1108	1210	1215	1310	1610	1615	2012	2517	3020
Tightening torque [Nm]	5.7	5.7	20	20	20	20	20	31	49	92

9 Electrical connection

Safety information

- ◆ Observe 2 *Important safety information*, page 1
- ◆ Prevent the ingress of water into the connection box.

Connection

- ◆ Check if the data on the nameplate matches the connection data.
- ◆ Complete the electrical connection according to the circuit diagram.
- ◆ Fans with EC- motors must be switched on/off via the control input.
- ◆ Connect the cable end in a dry environment.
- ◆ Install a circuit breaker in the permanent electrical installation, with a contact opening of at least 3 mm at each pole.

Protective grounding wire

The protective grounding must have a cross-section equal to or greater than that of the phase conductor.

Residual current circuit breaker

All-current-sensitive residual current circuit breakers are required for use in alternating-current systems with 50/60 Hz, in combination with electronic devices such as EC motors, frequency converters or uninterruptible power supplies (UPS).

9.1 Electrical connection accessories

The following wiring diagrams show the electrical connections between accessories and fans (with EC motor) or frequency converters (e.g. FRQ, FRQS, FXDM) which can be controlled with a 0–10V signal. If you are not sure if your fan is equipped with an EC- motor please see chapter 6 *Name plate and type key*, page 5.

motor/frequency converter



Wire- colours of motors with carried out cables: +10V = red 0..10V/PWM = yellow GND = blue

Controll via 0–10V signal

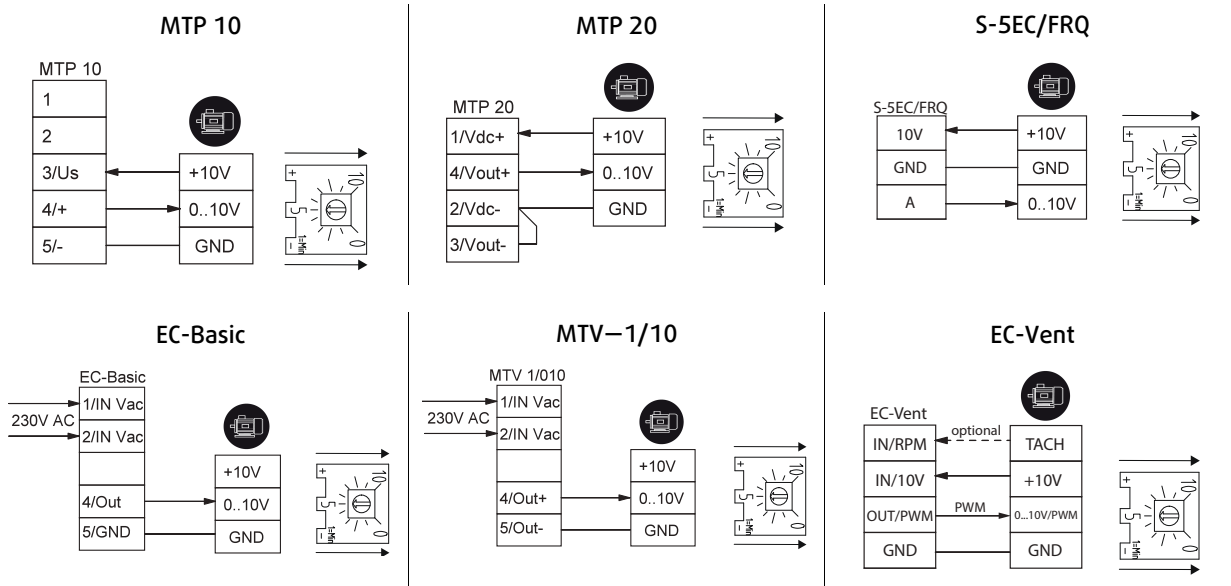

Controll via switching on / off

The following fans are equipped with a DIN1 connection:

Axzent 630EC	—	—	—	—
—	—	—	—	—

Din1: enable electronics

- enable: pin open or voltage 5–50 V DC
- disable: bridge to GND

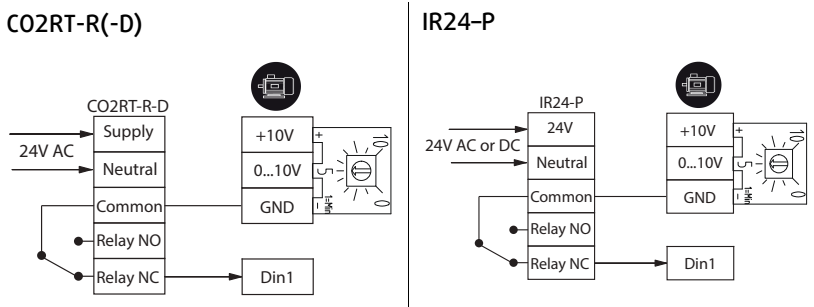

9.2 Protecting the motor



Note:

In fans equipped with an EC motor, there is no additional motor protection needed. The motor protection is integrated in the electronics of the motor.

Important

Damage to motor due to overcurrent, overload or short circuit.

- ◆ Lead-out temperature monitors must be integrated in the control circuit in such a way that, if a fault occurs, the motor cannot switch on again automatically after it has cooled down.
- ◆ Motor lines and temperature monitor lines should be laid separately on principle.
- ◆ Without thermal protection: Use a motor protection switch!

9.3 Variable-speed fans



Warning

Resonant frequencies may result in increased vibration in certain speed ranges. These vibrations may destroy components.

- ◆ Only operate the fan outside these speed ranges.
- ◆ Pass through these speed ranges so quickly that any vibration cannot exceed the admissible resonant frequency values.
- ◆ Observe the operating instructions of the frequency converter.



Caution

Damage as a result of incorrect commissioning of the frequency converter.

- ◆ Install the fan and frequency converter as near as possible to one another.
- ◆ Use shielded cables.
- ◆ All components (fan, frequency converter and motor) must be grounded.
- ◆ Avoid running the fan via the frequency converter below 10 Hz.
- ◆ Heating of the motor due to use of a variable frequency drive must be checked in the application by the customer.
- ◆ Never exceed the maximum impeller rotation speed indicated on the name plate of the fan.
- ◆ In any case Systemair recommends an all-pole sine filter if the fan is operated with a frequency converter.

10 Commissioning

Warranty claims can only be made if commissioning work is carried out correctly and written evidence thereof is provided.

Safety information

- ◆ Observe 2 *Important safety information*, page 1

Preconditions

- ◆ Installation and electrical connection have been correctly performed.
- ◆ Before switching the fan on, check for externally visible damage and ensure that the protective equipment functions properly.
- ◆ Inlet and outlet are free.
- ◆ Cable glands are tight.
- ◆ Safety devices have been fitted.

Commissioning of speed-controlled fans

Check the fan for vibrations at all normal operation speeds during commissioning. Determine and evaluate vibrations on the housing and bearing areas in accordance with DIN ISO 14694 depending on motor power and positioning.

Measurable vibration velocities depend e.g. on following factors:

- positioning
- bottom section/foundation state
- flow conditions

The working point of the fan, as well as used external devices and accessories, also influence the running characteristics.

Tests

Do the tests requested in the commissioning report (17 *Commissioning Report*, page 16)

11 Operation

Safety information

- ◆ Observe 2 *Important safety information*, page 1

12 Troubleshooting/maintenance/repair

Safety information

- ◆ Observe 2 Important safety information, page 1

12.1 Troubleshooting

Table 7 Troubleshooting

Fan does not run smoothly	Impeller imbalance	Rebalancing by a specialist company if possible, otherwise contact Systemair.
	Soiling on the impeller	Clean carefully, rebalance
	Material decomposition on the impeller due to aggressive material conveyed.	Contact Systemair
	Impeller rotates in wrong direction.	Change direction of rotation (swap two phases in case of a 3-phase motor). Contact Systemair
	Deformation of impeller due to excessive temperature.	Ensure that the temperature does not exceed the certified value/Install new impeller.
	Vibrations, oscillations	Check the installation of the fan/check the duct system, see 8 <i>Installation</i> , page 6.
Air output of fan too low	Fan operation in resonant frequency range	Consider chapter 9.3 <i>Variable-speed fans</i> , page 11
	Impeller rotates in wrong direction.	Change direction of rotation if possible, otherwise contact Systemair.
	Wrong wiring configuration (e.g. Y instead of Delta).	Check and possibly correct the wiring configuration.
	Pressure losses too high.	Optimize the line routing.
	Flow regulators not or only partly open.	Check opening position on site.
Grinding sounds when starting or operating the fan	Intake or pressure ducts are blocked.	Remove the blockage.
	Check if the duct connections of the fan are strained.	Loosen the duct connections and realign it.
Thermal contacts/resistors have triggered	Impeller rotates in wrong direction.	Change direction of rotation (swap two phases in case of a 3-phase motor).
	Missing phase	In case of a 3 phase standard motor (not EC), check if all 3 phase are present.
	Motor overheated	Check the cooling impeller (if used), measure the motor winding (if possible) / contact Systemair.
	Capacitor (if used) not or not correctly connected.	Connect the capacitor correctly.
	Motor blocked	Contact Systemair
Fan does not reach nominal speed	Defective motor winding	Check the winding by resistance measurement (if possible). Contact Systemair
	Control units (if used) such as frequency converter or transformer are set incorrectly.	Correct the settings of the control units.
	Mechanical blockage	Remove the blockage.

Troubleshooting cont'd

Motor does not rotate	Faulty supply voltage	Check the supply voltage, re-establish the voltage supply.
	Faulty connection	Allow the motor to cool down, find and resolve the cause of the fault.
	Temperature monitor has responded.	Allow the motor to cool down, find and resolve the cause of the fault.
Electronics/motor overheated	Insufficient cooling	Improve cooling.
	Overloaded motor	Check if the correct fan is used for your application.
	Ambient temperature too high	Check if the correct fan is used for your application.



Note:

For all other damage/defects, please contact Systemair.

12.2 Maintenance

Warranty claims can only be made if maintenance work is carried out correctly and written evidence thereof is provided.

We recommend regular maintenance intervals to ensure continuous fan operation. These maintenance intervals are specified in the "Activities" table below. In addition, the operator must carry out follow-up activities such as cleaning, replacing defective components or other corrective measures. For traceability reasons, a maintenance plan must be created which documents the work carried out. This must be created by the operator. If the operating conditions are "extreme", the maintenance intervals must be reduced so that maintenance is carried out more frequently. Examples of extreme operating conditions:

- Kitchen exhaust fans
- Durable ambient temperature > 30 °C or < -10 °C, or temperature fluctuations > 20 K

Table 8 Activities

Activity	Normal operating conditions		Extreme operating conditions	
	Every six months	Annually	Quarterly	Every six months
Check the fan and its components for visible damage, corrosion and contamination.		X		X
Check the impeller for damage and imbalance.		X		X
Check the condensate drain is working correctly.		X	X	
Clean the fan/ventilation system (see 13 <i>Cleaning</i> , page 14).	X		X	
Check the screwed connections for damages/defects and check that they are firmly seated.		X	See normal operating conditions	
Check the fan intake is free from contamination.		X		X
Check that the fan and its components are being used correctly.	X		See normal operating conditions	
Check the current consumption and compare this with the rated data.		X		X
Check the vibration dampers (if used) are working correctly and check for visible damage and corrosion.		X	See normal operating conditions	
Check the electrical and mechanical protective equipment is working correctly.		X	See normal operating conditions	
Check the fan's rating plate is legible.		X		X

Activities cont'd

Check the connection clamps and screwed cable connections for damage/defects, and check that they are firmly seated.		X	See normal operating conditions
Check the flexible connectors for damage.	X		See normal operating conditions

Spare parts

- ◆ Use original spare parts from Systemair only.
- ◆ When ordering spare parts, please specify the serial number of the fan. This can be found on the name plate.

13 Cleaning**Safety information**

- ◆ Observe *2 Important safety information*, page 1

Procedure**Keeping the fan clean extends its service life.**

- Install a filter monitor.
- Change the filters of the ventilation system.
- Do not use steel brushes or sharp-edged objects.
- Do not use a high-pressure cleaner (steam jet cleaner) under any circumstances.
- Do not bend the fan blades when cleaning.
- When cleaning the impeller, pay attention to balance weights that have been positioned
- Keep the airways of the fan clear and clean them if necessary with a brush.

14 Deinstallation/dismantling

Deinstall and dismantle the fan in reverse order of installation and electrical connection.

15 Disposal

- ◆ Ensure material is recycled. Observe national regulations.
- ◆ The device and the transport packaging are predominantly made from recyclable raw materials.
- ◆ Disassemble the fan into its components.
- ◆ Separate the parts according to:
 - reusable material
 - material groups to be disposed of (metal, plastics, electrical parts, etc.)

16 EU Declaration of conformity

The manufacturer: Systemair GmbH
 Seehöfer Straße 45
 97944 Boxberg
 Germany

Product designation: Thermo fans

Type designation: AxZent; KBR; MUB-K; MUB/T; MUB/T-S; DVN; DVNI

Since year of manufacture: 2018

The manufacturer declares that the above mentioned products in their design and construction and the version marketed by us complies with the harmonization legislation listed below:

EU directives:	2006/42/EC	Machinery directive
	2014/30/EU	Directive electromagnetic compatibility (EMC)
	2011/65/EU	RoHS directive

17 Commissioning Report

Warranty claims can only be made if commissioning work is carried out correctly and written evidence thereof is provided.

Fan

Description:

Article no.:

Manufacturing order no.:

Installer

Company:

Contact person:

Company address:

Tel. no.:

Email:

Operator (Place of installation)

Company:

Contact person:

Company address:

Tel. no.:

Email:

Type of connection

Yes No

Directly to mains

0-10 V signal (EC motor)

via contactor control

Transformer

Frequency converter

Sinus filter

Shielded cables

Motor protection

Yes No

Motor protection switch or motor protection relay

PTC resistor

Resistance value [Ω]:

Thermal contact

Electrical motor protection

Others:

Functional check

Yes No

Impeller easily rotatable (by hand)

Rotation direction acc. to directional arrow

Smooth running without unusual noise/
vibrations

Nominal data - Fan (name plate on fan housing)

Voltage [V]:

Current [A]:

Frequency [Hz]:

Power [kW]:

Fan impeller speed [rpm]:

Measured data at commissioning

Voltage [V]:

Temp. of transported air [$^{\circ}\text{C}$]:

Current L1 [A]*:	Fan impeller speed [rpm]:
Current L2 [A]:	Air volume [m ³ /s]:
Current L3 [A]:	Differential pressure [Pa]*:

*For single-phase fans, fill in line "Current L1 [A]"

*Δ- Pressure between suction-side and discharge of the fan

If an air flow measurement is not possible, this value can be calculated using the following formula:

$$\text{Duct cross-section [m}^2\text{]} \times \text{Flow speed [m/s]} = \text{Air volume [m}^3\text{/s]}$$

Grille measurement acc. to VDI 2044

	Yes	No
Commissioning of the fan successful?	<input type="checkbox"/>	<input type="checkbox"/>

Date, installer's signature

Date, operator's signature



Systemair GmbH
Seehöfer Str. 45
97944 Boxberg
Germany

Tel.: +49 (0)7930/9272-0
Fax: +49 (0)7930/9273-92

info@systemair.de
www.systemair.de