

Jet fans IV Smart AC, IV Smart EC, IV Smart EC CO

Installation and Operating Instructions

GB

Document in original language | · 004

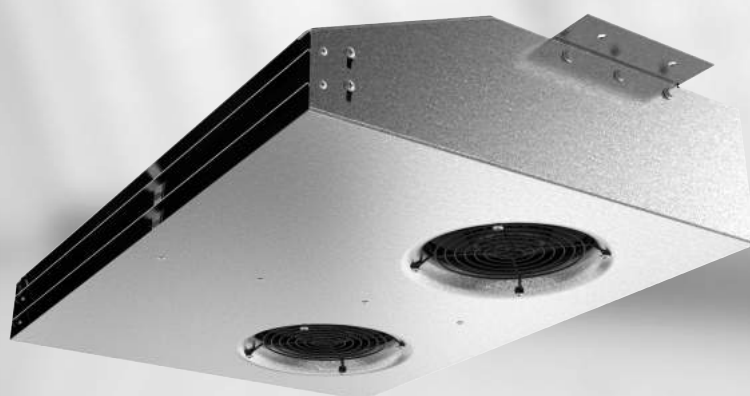

© Copyright Systemair AB
All rights reserved
E&OE

Systemair AB reserves the rights to alter their products without notice.
This also applies to products already ordered, as long as it does not affect the previously agreed specifications.

Contents

1	General information.....	1	11.2	Troubleshooting Fan	13
1.1	Notice symbols.....	1	11.3	Alarm and fault handling Carbon monoxide control unit	14
1.1.1	Instruction symbols.....	1	11.3.1	Thresholds for fault displays.....	14
2	Important safety information	1	11.3.2	Potential-free alarm contact	14
2.1	Personnel.....	1	11.3.3	Behaviour in the event of a CO alarm and fault handling	14
2.2	Personal protective equipment.....	2	11.4	Maintenance.....	14
2.3	5 rules of electrical safety	2	11.5	Spare parts	15
3	Warranty.....	2	12	Cleaning.....	15
4	Delivery, transport, storage	2	13	Deinstallation/dismantling.....	16
5	Description IV Smart.....	3	14	Disposal	16
5.1	Carbon monoxide control unit	3	15	Commissioning Report.....	17
5.2	Information on the effects of CO on humans.....	4	16	EU Declaration of conformity.....	18
5.3	Dimensions.....	4			
5.4	Fan and motor data	5			
5.5	Technical data of the controller.....	5			
5.6	Intended use of all IV Smart versions	5			
5.7	Incorrect use	5			
5.8	Terminal boxes	5			
6	Name plate and type key	6			
7	Installation.....	7			
7.1	Installation on the ceiling	7			
8	Electrical connection	8			
8.1	Wiring diagram IV Smart AC.....	8			
8.2	Wiring diagram IV Smart EC	9			
8.3	Wiring IV Smart EC-CO	10			
8.3.1	Fan speed specification	11			
8.4	Protecting the motor.....	11			
9	Commissioning	11			
9.1	Tests when activated EC CO version	12			
9.1.1	Function test.....	12			
9.1.2	Warm-up time	12			
9.1.3	Visual and audible display	12			
10	Operation	13			
11	Troubleshooting/maintenance/repair/CO alarm.....	13			
11.1	Safety information.....	13			

1 General information

1.1 Notice symbols



Danger

Direct hazard
Failure to comply with this warning will lead directly to death or to serious injury.



Caution

Hazard with a low risk
Failure to comply with this warning may lead to moderate injuries.



Warning

Potential hazard
Failure to comply with this warning may lead to death or serious injury.

Important

Hazard with risk of damage to objects
Failure to comply with this warning will lead to damage to objects.



Note:

Useful information and instructions

1.1.1 Instruction symbols

Instruction

- ◆ Carry out this action
- ◆ (if applicable, further actions)

Instruction with fixed sequence

1. Carry out this action
2. Carry out this action
3. (if applicable, further actions)

2 Important safety information

Planners, plant builders and operators are responsible for the proper assembly and intended use.

- ◆ Read the operating instructions completely and carefully.
- ◆ Keep the operating instructions and other valid documents, such as the circuit diagram or motor instructions, with the fan. They must always be available at the place of use.
- ◆ Observe and respect local conditions, regulations and laws.
- ◆ Abide by the system-related conditions and requirements of the system manufacturer or plant constructor.
- ◆ Safety elements may not be dismantled, circumvented or deactivated.
- ◆ Only use the fan in a flawless condition.
- ◆ Provide generally prescribed electrical and mechanical protective devices.
- ◆ During installation, electrical connection, commissioning, troubleshooting, and maintenance, secure the location and premises against unauthorised access.
- ◆ Do not circumvent any safety components or put them out of action.
- ◆ Keep all the warning signs on the fan complete and in a legible condition.
- ◆ The device is not to be used by persons (including children) with reduced physical, sensory or mental capabilities, or lack of experience and knowledge, unless they have been given supervision or instruction.
- ◆ Do not allow children to play with the device.

2.1 Personnel

The fan may only be used by qualified, instructed and trained personnel. The persons must know the relevant safety directives in order to recognise and to avoid risks. The individual activities and qualifications can be found in Table 1 *Qualifications*, page 2.

Table 1 Qualifications

Activities	Qualifications	
Storage, operation, transport, cleaning, disposal	Trained personnel (see following note)	
Electrical connection, commissioning, electrical disconnection	Electrical expert or matching qualification	
Installation, disassembly	Fitter or matching qualification	
Maintenance	Electrical expert or matching qualification	Fitter or matching qualification
Repair	Electrical expert or matching qualification	Fitter or matching qualification
	Smoke extraction fans and EX fans only by agreement with Systemair.	

**Note:**

The operator is responsible for ensuring that personnel are instructed and have understood the contents of the operating instructions. If something is unclear, please contact Systemair or its representative.

2.2 Personal protective equipment

◆ Wear protective equipment during all work in the vicinity of the fan.

- protective working clothes
- protective working gloves
- goggles
- protective working shoes
- helmet
- hearing protection

2.3 5 rules of electrical safety

1. Disconnect (disconnection of the electrical system from live components at all terminals)
2. Prevent reactivation
3. Test absence of voltage
4. Ground and short-circuit
5. Cover or restrict adjacent live parts

3 Warranty

For the assertion of warranty claims, the products must be correctly connected and operated, and used in accordance with the data sheets. Further prerequisites are a completed maintenance plan with no gaps and a commissioning report. Systemair will require these in the case of a warranty claim. The commissioning report is a component of this document. The maintenance plan must be created by the operator, see section 11.4 *Maintenance*, page 14.

4 Delivery, transport, storage

Safety information

Warning: Risk from rotating fan blades

◆ Prevent access by unauthorised persons by safety personnel or access protection.

Warning: Suspended loads

- ◆ Wear protective equipment during all work in the vicinity of the fan, details see 2.2 *Personal protective equipment*, page 2.
- ◆ Do not walk under suspended loads.
- ◆ Make sure that there is nobody under a suspended load.

Delivery

Each fan leaves our plant in an electrically and mechanically proper condition. We recommend transporting the fan to the installation site in the original packaging.

Checking delivery

- ◆ Check the packaging and the fan for transport damage. Any findings should be noted on the cargo manifest.
- ◆ Check completeness of the delivery.

Unpacking



Warning

When opening the transport packaging, there is a risk of damage from sharp edges, nails, staples, splinters etc.

- ◆ Unpack the fan carefully.
- ◆ Check the fan for obvious transport damage.
- ◆ Only remove the packaging shortly before assembly.
- ◆ Wear protective equipment during all work in the vicinity of the fan, details see 2.2 *Personal protective equipment*, page 2.

Transport

Safety information

Warning: Electrical or mechanical hazards due to fire, moisture, short circuit or malfunction.

- ◆ Never transport the fan by the connecting wire, terminal box, impeller, protection grille, inlet cone or silencer.
- ◆ In open transport, please make sure that no water can penetrate into the motor or other sensitive parts.
- ◆ We recommend transporting the fan to the installation site in the original packaging.

Caution: If transported without care during loading and unloading, the fan may be damaged.

- ◆ Load and unload the fan carefully.
- ◆ Use hoisting equipment that is suitable for the weight to be hoisted.
- ◆ Observe the transportation arrows on the packaging.
- ◆ Use the fan packaging exclusively as transport protection and not as a lifting aid.

Storage

- ◆ Store the fan in the original packaging in a dry, dust-free location protected against weather.
- ◆ Avoid the effects of extreme heat or cold.

Important

Hazard due to loss of function of the motor bearing

- ◆ Avoid storing for too long (recommendation: max. 1 year).
- ◆ Check that the motor bearing functions properly before installation.

5 Description IV Smart

IV Smart EC equipped with an EC motor

The fans are driven by EC motors. All motors are suitable for 50/60 Hz. The input voltage for single-phase units can vary between 200 and 277 V for three phase units between 380 and 480 V.

IV Smart AC – equipped with an AC motor

The fans are driven by two AC motors. All motors are suitable for 50/60 Hz.

IV Smart EC–CO – equipped with a carbon monoxide control unit

The fans are driven by two EC motors (see “IV Smart EC equipped with an EC motor”). The fan and the control unit are pre-wired and ready for use.

5.1 Carbon monoxide control unit

The CO control unit controls two EC fans with a 0–10 V control signal originating from a CO sensor. Both fans are controlled with the same 0–10 V signal and monitored for fan failure. The CO alarm is triggered based on the threshold and time specifications of DIN EN 50291-1.

5.2 Information on the effects of CO on humans



Warning

This CO control unit is designed to protect people from the acute effects of carbon monoxide. It cannot prevent the chronic effects of carbon monoxide exposure. The CO control unit can not fully protect people at special risk, such as those with particular medical conditions. In cases of doubt, consult a doctor.

The table below sets out the symptoms, the corresponding CO concentrations and lengths of time that a person needs to be exposed to this concentration until symptoms occur.

Table 2 Influence of carbon monoxide on the human body

CO concentration	Symptoms	Time until occurrence of symptoms
30 ppm	Maximum workplace concentration for 8 hours of work, no symptoms	-
100 ppm	Even after a prolonged period, no symptoms	-
200 ppm	Headache	2...3 h
300 ppm	Mild headache, dizziness, weakness, nausea	2...3 h
400 ppm	Frontal headache Life-threatening	1...2 h 3 h
800 ppm	Headache, dizziness, nausea, convulsions	Within 45 min
1600 ppm	Headache, dizziness and nausea Loss of consciousness Possible death	Within 20 min Within 2 h Within 1 h
3200 ppm	Headache, dizziness and nausea Death	Within 5...10 min Within 25...30 min
8000 ppm	Death	A few minutes

5.3 Dimensions

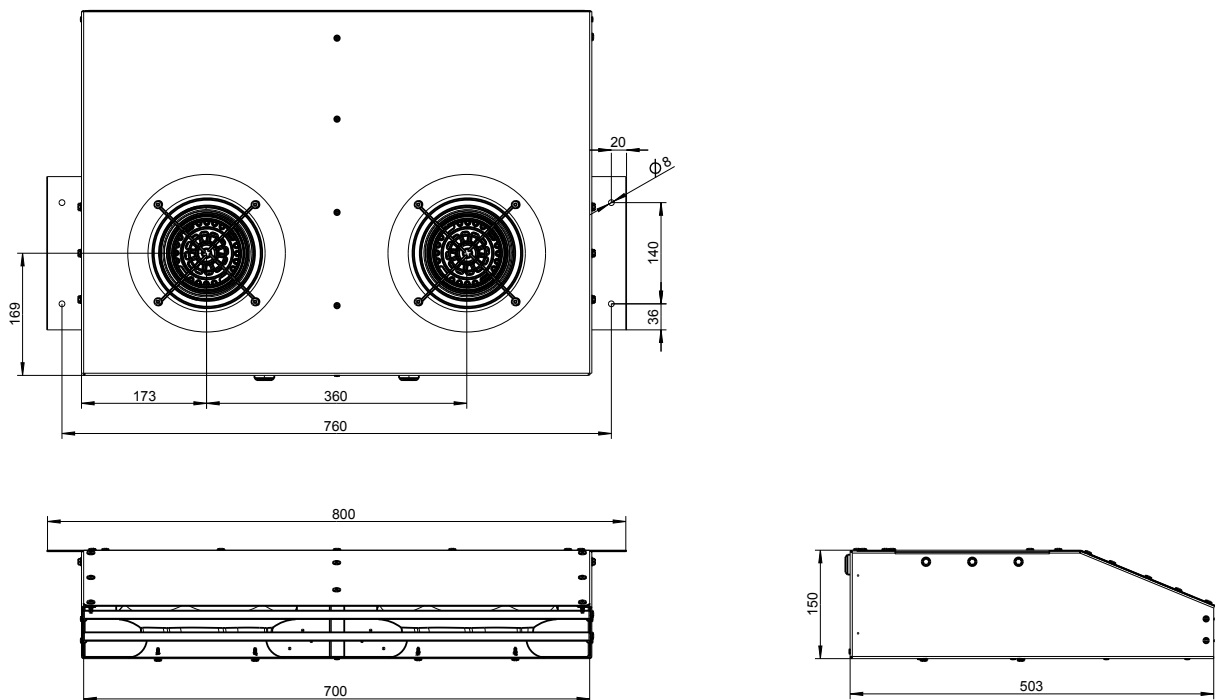

Fig. 1 Dimensions IV Smart

5.4 Fan and motor data

- Max. temperature of transported air, max. ambient temperature, sound pressure → see data sheet, available in our online catalogue.
- Voltage, current, enclosure class, weight → see name plate
- The motor data can be found on the name plate of the motor, or in the technical documents of the motor manufacturer.
- The data on the name plate of the fan apply to "standard air" according to ISO 5801.

5.5 Technical data of the controller

Voltage = 100...240 VAC

Frequency = 50...60 Hz

Table 3 CO control unit components

Component	Function
Fan	Two fans with a 0-10 V control input and hall output, for ventilation of the room being monitored.
CO sensor	CO sensor with 4...20 mA measuring signal output that reflects a 0...300 ppm CO concentration.
External alarm device (optional)	Connection of an alarm siren or alarm light

5.6 Intended use of all IV Smart versions

- The fans are intended for installation in underground and above-ground parking structures, to facilitate ventilation and cold smoke extraction.
- For optimum operation, the jet fan must be suspended horizontally from the ceiling in such a position that intake and outlet are unobstructed.
- The fan is suitable for conveying clean air.

5.7 Incorrect use

Incorrect use refers mainly to using the fan in another way to that described. The following examples are incorrect and hazardous:

- Conveying of explosive and combustible media
- Installation outside
- Conveying of aggressive media
- Operation in an explosive atmosphere

5.8 Terminal boxes

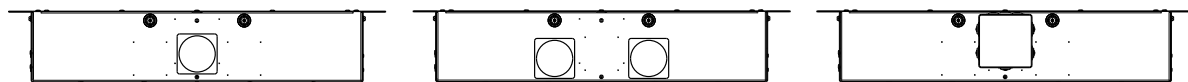

IV Smart AC

IV Smart EC

IV Smart CO

6 Name plate and type key

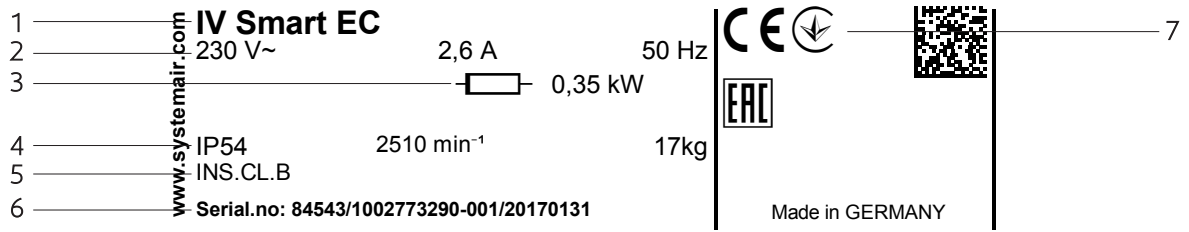

- | | | | |
|---|---|---|---|
| 1 | Type designation | 5 | Insulation class |
| 2 | Voltage/current/frequency | 6 | Article number/production number/manufacturing date |
| 3 | Input power | 7 | Certifications |
| 4 | Enclosure class/fan impeller speed/weight | | |

Table 4 Type key

IV Smart	EC	-	-	No controller
			CO	Equipped with a carbon monoxide control unit
Motor type				
		EC	Electronically commutated/1 phased	
		AC	2 poled/voltage controllable/1 phased	
Fan type				
		Induction fan Smart		

7 Installation

Warning: Danger from falling fan or fan parts.

- ◆ Check the surface before installation for load bearing capacity.
- ◆ Consider all static and dynamic loads when selecting hoisting equipment and fastening components.

General safety information

- ◆ Installation may only be carried out by adequately qualified persons, details see Table 1 *Qualifications*, page 2.
- ◆ Abide by the system-related conditions and requirements of the system manufacturer or plant constructor.
- ◆ Do not dismantle or circumvent safety elements, or put them out of function.
- ◆ Provide contact and intake protection and ensure safety distances according to DIN EN ISO13857 and DIN 24167-1.
- ◆ Prevent the possibility of foreign bodies being drawn in.

Preconditions

- ◆ Ensure that the fan and all its components are undamaged.
- ◆ Ensure that there is enough space to install the fan.
- ◆ Protect against dust and moisture when installing.
- ◆ Ensure that the information on the name plates (fan and motor) matches up with the operating conditions.
- ◆ Fit the fans in such a way that there is sufficient access for troubleshooting, maintenance and repair.

7.1 Installation on the ceiling

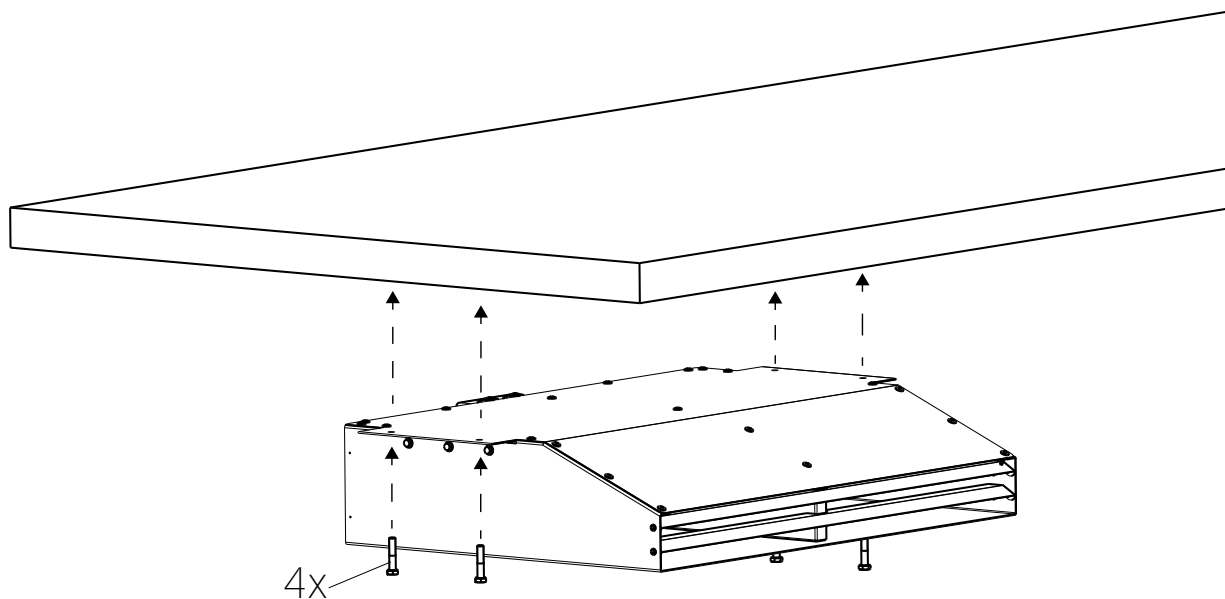

Installation IV Smart

8 Electrical connection

Safety information / Preconditions

Warning: Danger from electrical voltage!

- ◆ Observe the 5 rules of electrical safety, see 2.3 5 rules of electrical safety, page 2.
- ◆ Prevent the ingress of water into the connection box.
- ◆ Electrical connection may only be carried out by adequately qualified persons, details see Table 1 Qualifications, page 2.

Connection

- ◆ Check if the data on the nameplate matches the connection data.
- ◆ Complete the electrical connection according to the circuit diagram.
- ◆ Fans with EC- motors must be switched on/off via the control input.
- ◆ Use all of the locking screws.
- ◆ Insert the screws by hand to avoid damaging the thread.
- ◆ Tighten all glands well in order to guarantee protection class IP.
- ◆ Screw the lid of the terminal box/inspection switch evenly tight.
- ◆ Connect the cable end in a dry environment.
- ◆ Install a circuit breaker in the permanent electrical installation, with a contact opening of at least 3 mm at each pole.

Protective grounding wire

The protective grounding must have a cross-section equal to or greater than that of the phase conductor.

Residual current circuit breaker

All-current-sensitive residual current circuit breakers are required for use in alternating-current systems with 50/60 Hz, in combination with electronic devices such as EC motors, frequency converters or uninterruptible power supplies (UPS).

8.1 Wiring diagram IV Smart AC

Color	Function/pin assignment	
Black	L	Power supply 230 V AC, 50...60 Hz
Blue	N	Neutral conductor
Green/Yellow	PE	Protective conductor

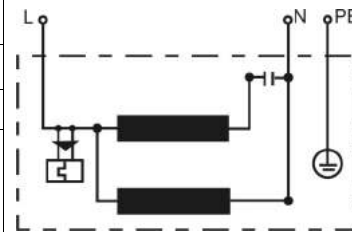

8.2 Wiring diagram IV Smart EC

The connection cables of the two motors of the IV Smart are carried out in the terminal boxes.

Terminal box – Power supply

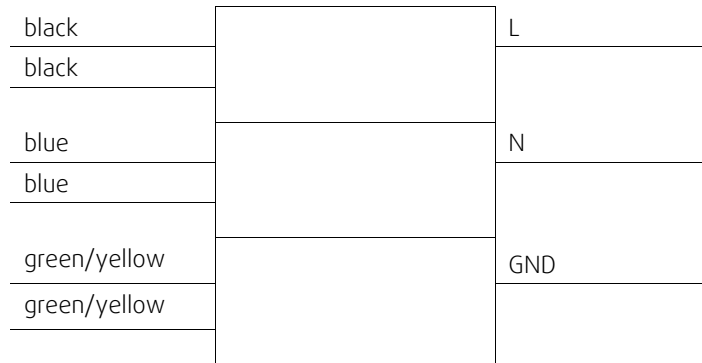

Terminal box – Control interface

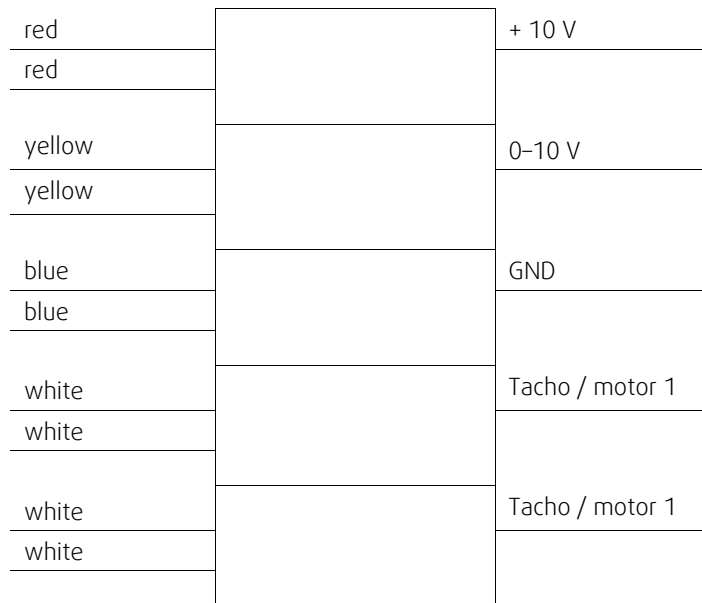

Terminal assignment motor

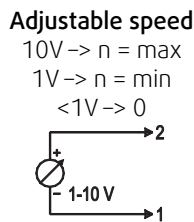
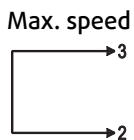

Adjustable speed through PWM

1...10 KHz
100 % PWM → n = max
10 % PWM → n = min
< 10 % → 0

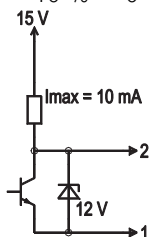

Adjustable speed through potentiometer

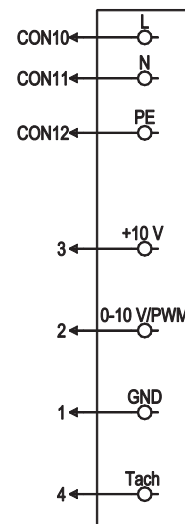
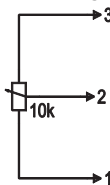

Wire no.	Connection	Color	Function/assignment
CON10	L	black	Power supply 230 V AC, 50...60 Hz, see name plate for voltage range

CON11	N	blue	Neutral conductor
CON12	PE	green/yellow	GND-connection
2	0...10 V PWM	yellow	Controller input 0...10 V or PWM
4	Tacho	white	Speed output: Open Collector, 1 impulse per revolution, electrically isolated, Isink_max = 10 mA
3	10 V	red	Voltage output 10 V, I_max. 10 mA, short-circuit-proof, power supply for external devices.
1	GND	blue	GND-connection of the controller interface

8.3 Wiring IV Smart EC-CO

The wiring diagram of the IV Smart EC-CO fan is not included in this document, but within this delivery.

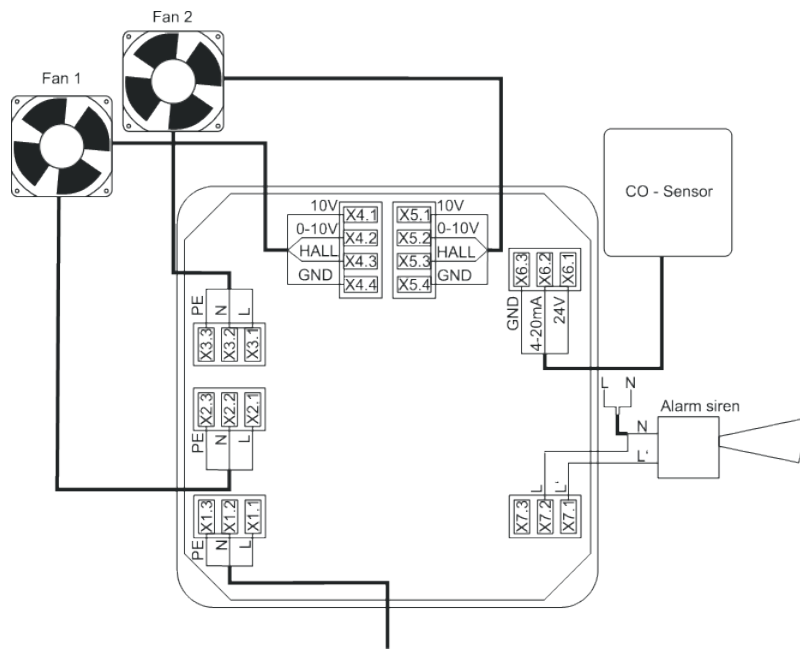

Table 5 Electrical connections

Name	Occupancy	Designation	Description
X1	1. L	X1 SUPPLY	Supply connection to the control unit
	2. N		
	3. PE		
X2	1. L	X2 FAN1	Supply connection to fan 1. Voltage corresponds to the control unit's supply voltage
	2. N		
	3. PE		
X3	1. L	X3 FAN2	Supply connection to fan 2. Voltage corresponds to the control unit's supply voltage
	2. N		
	3. PE		
X4	1. 10 V	X4 FAN1	Control connection to fan 1. Speed specification and speed feedback. If the fan has a 10 V output, it can be connected to terminal X4.1.
	2. 0-10 V		
	3. HALL		
	4. GND		
X5	1. 10 V	X5 FAN2	Control connection to fan 2. Speed specification and speed feedback. If the fan has a 10 V output, it can be connected to terminal X5.1.
	2. 0-10 V		
	3. HALL		
	4. GND		

Electrical connections cont'd

X6	1. 24 V	X6 SENSOR	Connection for CO sensor supply connection and measuring signal connection
	2. 4-20 mA		
	3. EARTH		
X7	1. NC	X7 ALARM	Potential-free alarm contact connection option for controlling an alarm siren or other auxiliary device.
	2. COM		
	3. NO		

8.3.1 Fan speed specification

The minimum fan speed can be set via a potentiometer in the range from 20 % to 40 %. The potentiometer is only accessible once the housing cover has been removed. The fan speed increases proportionately to the CO concentration until the maximum speed at 50 ppm. If a fault is detected, the fans operate at maximum speed in order to remove any raised CO concentrations in the air. The following table provides information about the control unit's speed specifications to the fans.

Table 6 Fan speed specification

CO concentration	Speed specification values	Comment
CO < 15 ppm Switch-off hysteresis 10 ppm	0 V	Fan standstill
CO = 15 ppm	2 V...4 V (min.)	Speed depending on set value
15 ppm < CO ≤ 50 ppm	Min....10 V	Linear rise in the characteristic curve analogue to the CO concentration starting with the minimum through to the maximum fan speed
50 ppm < CO	10 V	Maximum fan speed
Fault	10 V	Maximum fan speed

8.4 Protecting the motor**Note:**

In fans equipped with an EC motor, there is no additional motor protection needed. The motor protection is integrated in the electronics of the motor.

Important**Damage to motor due to overcurrent, overload or short circuit.**

- ◆ Lead-out temperature monitors must be integrated in the control circuit in such a way that, if a fault occurs, the motor cannot switch on again automatically after it has cooled down.
- ◆ Motor lines and temperature monitor lines should be laid separately on principle.
- ◆ Without thermal protection: Use a motor protection switch!

9 Commissioning

Warranty claims can only be made if commissioning work is carried out correctly and written evidence thereof is provided.

Safety information

- ◆ Commissioning may only be carried out by adequately qualified persons, details see Table 1 *Qualifications*, page 2.

Preconditions

- ◆ Installation and electrical connection have been correctly performed.
- ◆ Residual material from installation and foreign objects have been removed from the fan and ducts.
- ◆ Before switching the fan on, check for externally visible damage and ensure that the protective equipment functions properly.
- ◆ Inlet and outlet are free.
- ◆ Cable glands are tight.
- ◆ Data on the name plate corresponds with the connection data.
- ◆ Safety devices have been fitted.

Tests

During commissioning, the following sequence must be observed:

AC motor

1. Switch the fan on.
2. Do the tests requested in the commissioning report (15 *Commissioning Report*, page 17)
Speed controllable fans: "Measured data at commissioning" at maximum speed
3. Switch the fan off.

EC motor

When the mains are switched on, the motor starts an initialization (a few seconds). After the initialization the control input is active.

1. Switch the fan on via the control input.
2. Do the tests requested in the commissioning report (15 *Commissioning Report*, page 17)
Speed controllable fans: "Measured data at commissioning" at maximum speed
3. Switch the fan off via the control input.

9.1 Tests when activated EC CO version

9.1.1 Function test

A function test is carried out once the voltage supply is connected, with the displays, the potential-free contact and the fans being switched on briefly. The control unit has been installed correctly if the power display lights up permanently, the CO alarm and fault display goes out after 2 seconds and the audible display does the same after 1 second. The potential-free contact must tighten after 1 second and therefore establish a connection between X7.2 and X7.3. In addition, no faults must be displayed after around 15 seconds. In the Chapter 9.1.3 *Visual and audible display*, page 12 the meaning of the different signal types are explained.

9.1.2 Warm-up time

Once the operating voltage has been connected, the control unit is in a warm-up state for around 6.5 minutes. During this time, no CO measurements are carried out and no CO alarms are triggered. To ensure basic ventilation and to remove any raised CO concentrations in the air, the fans are controlled at a minimum speed. The warm-up time is needed to give the CO sensor enough time for the CO measuring transducer's warm-up phase. Once the warm-up time has elapsed, the control unit switches to its normal operating state (ready) and CO analysis takes place.

9.1.3 Visual and audible display

The table below distinguishes between the displays based on the control unit's four operating modes.

Table 7 Visible and audible display

Operating mode	Audible signal generator	CO alarm Red LED	Operation Green LED	Fault Yellow LED
Warm-up time	No	No	On	No
Ready	No	No	On	No
CO alarm	On	Rapid flashing 2 Hz	On	No
Fault	2 fast sounds / min	No	On	Rapid flashing 2 Hz

Table 8 Carbon monoxide alarm thresholds

CO concentration for activation of the CO alarm	Control unit trigger times	CO concentration for resetting of the active CO alarm
30 ppm	No alarm	No alarm

Carbon monoxide alarm thresholds cont'd

50 ppm	After around 75 min	< 40 ppm
100 ppm	After around 25 min	< 40 ppm
300 ppm	After around 1 min	< 40 ppm

10 Operation

Safety information

Warning: Hazard from electrical voltage or moving components.

- ◆ The device may only be operated by adequately qualified persons, details see Table 1 *Qualifications*, page 2.
- ◆ Only use the fan in accordance with the operating instructions and the operating instructions for the motor.

11 Troubleshooting/maintenance/repair/CO alarm

11.1 Safety information

- ◆ Troubleshooting/maintenance/repair may only be carried out by adequately qualified persons, details see Table 1 *Qualifications*, page 2.
- ◆ Observe the 5 rules of electrical safety, see 2.3 *5 rules of electrical safety*, page 2.
- ◆ The impeller must be at a standstill.

11.2 Troubleshooting Fan

Table 9 Troubleshooting

Problem	Possible causes	Remedy
Fan does not run smoothly	Impeller imbalance	Rebalancing by a specialist company if possible, otherwise contact Systemair.
	Soiling on the impeller	Clean carefully, rebalance
	Material decomposition on the impeller due to aggressive material conveyed.	Contact Systemair
	Impeller rotates in wrong direction.	Contact Systemair
	Deformation of impeller due to excessive temperature.	Ensure that the temperature does not exceed the certified value/Contact Systemair.
	Vibrations, oscillations	Check the installation of the fan.
Air output of fan too low	Impeller rotates in wrong direction.	Contact Systemair
	Mechanical blockage	Remove the blockage
Motor does not rotate	Faulty supply voltage	Check the supply voltage, re-establish the voltage supply
	Faulty connection	Disconnect from the power supply, correct the connection, see circuit diagram.
	Temperature monitor has responded	Allow the motor to cool down, find and resolve the cause of the fault.
Electronics/motor overheated	Insufficient cooling	Improve cooling.
	Overloaded motor	Check if the correct fan is used for your application.
	Ambient temperature too high	Check if the correct fan is used for your application.

**Note:**

For all other damage/defects, please contact Systemair. Defective safety-relevant fans (for Ex and smoke extraction applications) must be replaced completely.

11.3 Alarm and fault handling Carbon monoxide control unit

The control unit continuously monitors the sensor's function, as well as the function of the fans. The following sub-points describe the the meaning of the fault and CO-Alarm display and the way in which they should be responded to.

11.3.1 Thresholds for fault displays

The control unit distinguishes between two fault types, which are specified in more detail in the table below.

Table 10 Fault display thresholds

Fault type	Setting threshold	Reset threshold	Comment
Fan failure	RPM < 130 rpm / min	RPM ≥ 180 rpm / min	Fan fault or fault with the fan supply cables -> Signalled after 10 seconds
Sensor fault	I _{4-20mA} < 3.0 mA	I _{4-20mA} ≥ 3.5 mA	Short circuit or break in the sensor cable -> Signalled after 3 seconds

11.3.2 Potential-free alarm contact

The illustration below explains the alarm contact's switching states.

Control terminals e.g. to connect an alarm signal

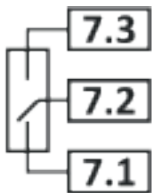

CO alarm – fault or voltage free

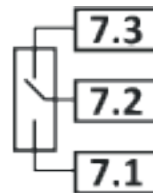

Operating ok

11.3.3 Behaviour in the event of a CO alarm and fault handling

The control unit distinguishes between two fault types, which are specified in more detail in the table below.

Table 11 Behaviour in the event of a CO alarm and faults

No.	Problem	Possible cause	Remedy / suggested solution
1	CO alarm	Critical CO concentration reached	<ol style="list-style-type: none"> 1. If the fan and control unit is installed in a garage and your vehicle engine is idling, switch the engine off. 2. Leave the room immediately and seek fresh air. Check that everyone is present. Do not go back into the room before it has been ventilated and the CO alarm has stopped. 3. If the alarm triggers again after 24 hours, repeat steps 1-2 and call the emergency gas services (please check you have their number now) and if necessary notify the relevant gas fitter.
2	Fault	- Fan failure - Sensor fault	Contact Systemair

11.4 Maintenance

Warranty claims can only be made if maintenance work is carried out correctly and written evidence thereof is provided.

We recommend regular maintenance intervals to ensure continuous fan operation. These maintenance intervals are specified in the "Activities" table below. In addition, the operator must carry out follow-up activities such as cleaning,

replacing defective components or other corrective measures. For traceability reasons, a maintenance plan must be created which documents the work carried out. This must be created by the operator. If the operating conditions are "extreme", the maintenance intervals must be reduced so that maintenance is carried out more frequently. Examples of extreme operating conditions:

- Durable ambient temperature > 30 °C or < -10 °C, or temperature fluctuations > 20 K

Table 12 Activities

Activity	Normal operating conditions		Extreme operating conditions	
	Every six months	Annually	Quarterly	Every six months
Check the fan and its components for visible damage, corrosion and contamination.		X		X
Check the impeller for damage and imbalance.		X		X
Check the condensate drain is working correctly.		X	X	
Clean the fan/ventilation system (see 12 <i>Cleaning</i> , page 15).	X		X	
Check the screwed connections for damages/defects and check that they are firmly seated.		X	See normal operating conditions	
Check the fan intake is free from contamination.		X		X
Check that the fan and its components are being used correctly.	X		See normal operating conditions	
Check the current consumption and compare this with the rated data.		X		X
Check the vibration dampers (if used) are working correctly and check for visible damage and corrosion.		X	See normal operating conditions	
Check the electrical and mechanical protective equipment is working correctly.		X	See normal operating conditions	
Check the fan's rating plate is legible.		X		X
Check the connection clamps and screwed cable connections for damage/defects, and check that they are firmly seated.		X	See normal operating conditions	
Check the flexible connectors for damage.	X		See normal operating conditions	



Note:

For all other damage/defects, please contact Systemair. Defective safety-relevant fans (for Ex and smoke extraction applications) must be replaced completely.

11.5 Spare parts

- ◆ Use original spare parts from Systemair only.
- ◆ When ordering spare parts, please specify the serial number of the fan. This can be found on the name plate.

12 Cleaning

Safety information

- ◆ Cleaning may only be carried out by adequately qualified persons, details see Table 1 *Qualifications*, page 2.
- ◆ Observe the 5 rules of electrical safety, see 2.3 *5 rules of electrical safety*, page 2.
- ◆ The impeller must be at a standstill.

Procedure

Important**Keeping the fan clean extends its service life.**

- ◆ Install a filter monitor.
- ◆ Do not use steel brushes or sharp-edged objects.
- ◆ Do not use a high-pressure cleaner (steam jet cleaner) under any circumstances.
- ◆ Do not bend the fan blades when cleaning.
- ◆ When cleaning the impeller, pay attention to balance weights that have been positioned
- ◆ Keep the airways of the fan clear and clean them if necessary with a brush.

13 Deinstallation/dismantling

Deinstall and dismantle the fan in reverse order of installation and electrical connection.

14 Disposal

- ◆ Ensure material is recycled. Observe national regulations.
- ◆ The device and the transport packaging are predominantly made from recyclable raw materials.
- ◆ Disassemble the fan into its components.
- ◆ Separate the parts according to:
 - reusable material
 - material groups to be disposed of (metal, plastics, electrical parts, etc.)

15 Commissioning Report

Warranty claims can only be made if commissioning work is carried out correctly and written evidence thereof is provided.

Fan

Description:

Article no.:

Manufacturing order no.:

Installer

Company:

Contact person:

Company address:

Tel. no.:

Email:

Operator (Place of installation)

Company:

Contact person:

Company address:

Tel. no.:

Email:

Type of connection

Yes No

Directly to mains

0-10 V signal (EC motor)

via contactor control

Transformer

Frequency converter

Sinus filter

Shielded cables

Motor protection

Yes No

Motor protection switch or motor protection relay

PTC resistor

Resistance value [Ω]:

Thermal contact

Electrical motor protection

Others:

Functional check

Yes No

Impeller easily rotatable (by hand)

Rotation direction acc. to directional arrow

Smooth running without unusual noise/
vibrations

Nominal data - Fan (name plate on fan housing)

Voltage [V]:

Current [A]:

Frequency [Hz]:

Power [kW]:

Fan impeller speed [rpm]:

Measured data at commissioning

Voltage [V]:

Temp. of transported air [$^{\circ}$ C]:

Current L1 [A]*:	Fan impeller speed [rpm]:
Current L2 [A]:	Air volume [m3/s]:
Current L3 [A]:	Differential pressure [Pa]*:
<small>*For single-phase fans, fill in line "Current L1 [A]"</small>	<small>*Δ- Pressure between suction-side and discharge of the fan</small>

If an air flow measurement is not possible, this value can be calculated using the following formula:

$$\frac{\text{Duct cross-section [m}^2\text{]}}{\text{X}} \times \frac{\text{Flow speed [m/s]}}{\text{Grille measurement acc. to VDI 2044}} = \text{Air volume [m}^3\text{/s]:}$$

	Yes	No
Commissioning of the fan successful?	<input type="checkbox"/>	<input type="checkbox"/>

Date, installer's signature

Date, operator's signature

16 EU Declaration of conformity

The manufacturer: Systemair GmbH
 Seehöfer Straße 45
 DE-97944 Boxberg
 Germany
 +49 (7930) 9272 - 553

Product designation: Jet fans

Type designation: AJR; AJ8; AJR (B); AJ8 (B); AJ (F); AJR-TR; IV; IV smart; prioJet

Since of manufacture: 2016

The manufacturer declares that the above mentioned products in their design and construction and the version marketed by us complies with the Harmonization legislation listed below:

EU directives:	2006/42/EC	Machinery directive
	2014/30/EU	Directive electromagnetic compatibility (EMC)
	2011/65/EU	RoHS directive
	2009/125/EC	ErP guidelines



Systemair GmbH
Seehöfer Str. 45
97944 Boxberg
Germany

Tel.: +49 (0)7930/9272-0
Fax: +49 (0)7930/9273-92

info@systemair.de
www.systemair.de