

INSTALLATION

Central ventilation unit with heat recovery

- » LWZ 5 CS Premium
- » LWZ 8 CS Premium

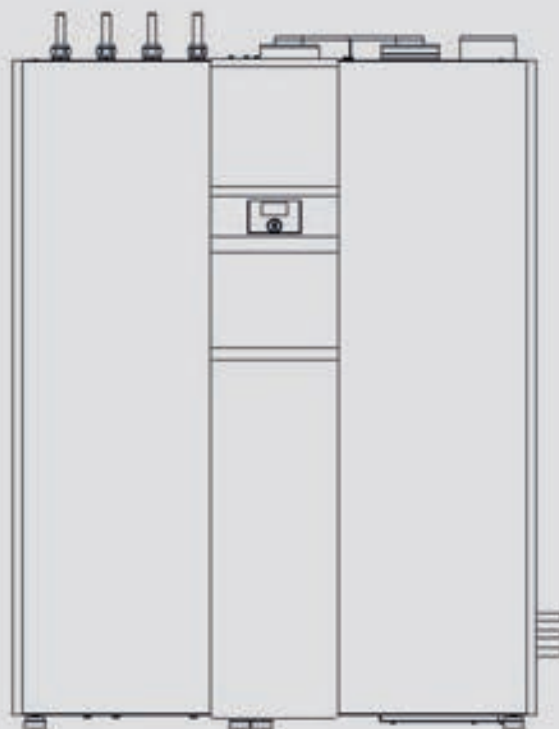

STIEBEL ELTRON

SPECIAL INFORMATION

INSTALLATION

1. General information	3
1.1 Relevant documents	3
1.2 Information on the appliance	3
1.3 Standardised output data	3
2. Safety	4
2.1 General safety instructions	4
2.2 Instructions, standards and regulations	4
2.3 Operation of the appliance in buildings with combustion equipment	4
3. Appliance description	5
3.1 Standard delivery	5
3.2 Required accessories	5
3.3 Additional accessories	5
3.4 Appliance functions	5
4. Preparation	7
4.1 Installation site	7
4.2 Air routing	8
4.3 Sound emissions	8
4.4 Electrical installation	10
4.5 Oxygen diffusion	10
4.6 Transport	10
5. Installation	11
5.1 Siting the function module	11
5.2 Installing the cylinder module	13
5.3 Connecting modules	14
5.4 Heating water connection	16
5.5 Water connection	17
5.6 Filling the DHW cylinder	18
5.7 Option: Connecting the second DHW cylinder	18
5.8 Condensate drain and overpressure valve	18
5.9 Electrical connection	18
5.10 Filling and venting the heating system	22
5.11 Fitting the appliance casing	24
5.12 Outdoor air and exhaust air hose installation	25
5.13 Installing extract air and supply air pipes	26
6. Commissioning	26
6.1 Checks before commissioning	26
6.2 Filter insertion	27
6.3 Commissioning via the programming unit	27
6.4 Recommissioning	27
7. Appliance shutdown	28
8. Troubleshooting	28
8.1 Exhaust air fan is catching	28
8.2 Cleaning defrost pan	28
8.3 Circulation pump	29
8.4 Fault messages in the programming unit	29
9. Maintenance and cleaning	29
9.1 Cleaning the air/air heat exchanger	29
9.2 Cleaning the outdoor air filter	30
9.3 Cleaning the evaporator fins	30
9.4 Cleaning the condensate drain	31

9.5 Cleaning the filter ball valve	31
9.6 Replacing the anode	31
9.7 Checking the diaphragm expansion vessels	32
10. Specification	33
10.1 Dimensions and connections	33
10.2 Connection examples	34
10.3 Application range	34
10.4 Sensor resistance values	34
10.5 Wiring diagram	35
10.6 Output graph	38
10.7 Available external head of the circulation pump	39
10.8 Fan curve	39
10.9 Data table	40



SPECIAL INFORMATION INSTALLATION

- Observe all applicable national and regional regulations and instructions during installation.
- The appliance is not approved for outdoor installation.
- Observe the requirements concerning the installation room (see chapter „Specification / Data table“).
- Observe minimum clearances (see chapter „Preparations / Installation site“).
- The connection to the power supply must be in the form of a permanent connection. Ensure the appliance can be separated from the power supply by an isolator that disconnects all poles with at least 3 mm contact separation.
- Observe the fuse protection required for the appliance (see chapter „Specification / Data table“).
- Drain the appliance as described in chapter „Shutdown“.
- Install a type-tested safety valve in the cold water supply line.
- The maximum pressure in the cold water supply line must be at least 20 % below the response pressure of the safety valve. If the maximum pressure in the cold water supply line is higher, install a pressure reducing valve.
- Size the drain so that water can drain off unimpeded when the safety valve is fully opened.
- Fit the discharge pipe of the safety valve with a constant downward slope and in a room free from the risk of frost.
- The safety valve discharge aperture must remain open to atmosphere.

1. General information

These instructions are intended for qualified contractors.

1.1 Relevant documents

-  336513 Operation
-  337705 Commissioning / Notification list

1.2 Information on the appliance

Connections

Symbol	Meaning
	Inlet / intake
	Drain / outlet
	Heating
	Condensate
	Safety valve drain
	Solar thermal
	Outdoor air
	Exhaust air
	Extract air
	Supply air

1.3 Standardised output data

Information on determining and interpreting the specified standardised output data

1.3.1 Standard: EN 13141-7, EN 14511, EN 16147

The output data specifically mentioned in text, diagrams and technical datasheets has been calculated according to the test conditions of the standards shown in the heading of this section. However, there is a deviation from the standard EN 14511 in the performance specifications for inverter driven air source heat pumps with source temperatures $> -7^{\circ}\text{C}$, as these are partial load values. The associated percentage weighting in the partial load range can be found in EN 14825 and EHPA quality label regulations.

Generally, the test conditions stated above will not fully match the conditions found at the installation site of the system user.

Depending on the chosen test method and the extent to which this method differs from the test conditions defined in the first paragraph of this section, any deviations can be considerable. Additional factors that have an influence on the test values are the measuring equipment, the system configuration, the age of the system and the flow rates.

Confirmation of the specified output data can only be obtained if the test conducted for this purpose is also performed in accordance with the test conditions defined in the first paragraph of this section.

2. Safety

Only a qualified contractor should carry out installation, commissioning, maintenance and repair of the appliance.

2.1 General safety instructions

We guarantee trouble-free function and operational reliability only if original accessories and spare parts intended for the appliance are used.

2.1.1 Electrical installation



WARNING Electrocutation

Carry out all electrical connection and installation work in accordance with national and regional regulations.



WARNING Electrocutation

Isolate the appliance from the power supply prior to commencing any work in the interior of the appliance.



WARNING Electrocutation

The connection to the power supply must be in the form of a permanent connection. The appliance must be able to be separated from the power supply by an isolator that disconnects all poles with at least 3 mm contact separation. This requirement can be met by contactors, isolators, fuses, etc.



Material losses

The specified voltage must match the mains voltage. Observe the type plate.

2.2 Instructions, standards and regulations



Note

Observe all applicable national and regional regulations and instructions.



WARNING Burns

In connection with the fire prevention regulations concerning the installation of ventilation systems, observe all country-specific regulations and requirements. In Germany, these are particularly the building regulation guideline on fire prevention requirements of ventilation systems in its applicable version.

2.3 Operation of the appliance in buildings with combustion equipment

If the building contains combustion equipment (tiled stoves, fireplaces, etc.), approval must be obtained from the responsible flue gas inspector. The flue gas inspector assesses whether all statutory regulations are observed. We recommend that the flue gas inspector be involved at an early stage in the design process.

For simultaneous operation of combustion equipment and a ventilation unit, we recommend choosing approved room sealed combustion equipment. Planning should always include the option of installing safety equipment (e.g. differential pressure switch).

A 5-core cable must be routed from the combustion equipment to the appliance or to the control panel fuse box to which the appliance is connected.



WARNING Injury

Ensure that no flue gas can enter the installation room and that combustion equipment will always be supplied with sufficient combustion air. Tested safety equipment must be installed to monitor the chimney draught and to switch off the ventilation unit in the event of a fault.

Requirements of the safety equipment

The equipment for differential pressure monitoring should fulfil the following requirements:

- Monitoring of the differential pressure between the connection piece to the chimney and the room where the combustion equipment is installed.
- Possibility of matching the shutdown value for the differential pressure to the minimum draught requirement for the combustion equipment.
- Floating contact to switch off the ventilation or heat pump function.
- Optional connection of a temperature capturing device so that differential pressure monitoring is only enabled when the combustion equipment is in operation and so that unwanted shutdowns due to environmental influences can be avoided.



Note

Differential pressure switches that use the pressure differential between the outdoor air pressure and the pressure in the room where the combustion equipment is sited as a response criterion are not suitable.

- ▶ XD03-13/14: Connect the safety equipment using a floating contact.

Triggering the safety equipment may shut down the domestic ventilation system and block the integral heat pump of the appliance. You can determine how the appliance will behave following a triggering of the safety equipment using the „STOVE / FIREPLACE“ parameter.

If you want the entire appliance to be switched off when the safety equipment is triggered, you can integrate the safety of equipment in the same way as an underfloor heating system thermostat (see chapter „Specification / Connection examples“).

Appliance description

As the appliance can produce negative pressure in the installation room, we recommend using a tightly sealing door between the installation room and the living space containing combustion equipment. If, due to its use, the installation room is connected to the extract air system, you must also make special arrangements for a supply air vent in the installation room, to prevent any further increase in the negative pressure in this room. The negative pressure created by the appliance in the installation room is heavily influenced by the pressure drop in the outdoor air line. For this reason, the outdoor air line in particular should be as short as possible.



Note

The maximum permissible pressure drop (see chapter "Specification / Data table / Max. pressure drop, outdoor air") must not be exceeded.

During regular operation, the ventilation unit promotes a balanced air flow rate and no pressure differences occur. Do not switch off the mechanical ventilation component of the appliance if the combustion equipment is in operation.



WARNING Injury

If no safety equipment is installed, open the parameter "STOVE / FIREPLACE" and select the option "N/C MONITORING". This option switches off the heat pump as soon as mechanical ventilation is deactivated.



WARNING Injury

If you notice flue gas escaping from the combustion equipment, switch off any air extraction appliances, e.g. exhaust air extractor hoods, exhaust air tumble dryers, the central vacuum cleaning system and the ventilation unit. Interrupt any voltage supply to the ventilation unit, including the integral heat pump, via the fuses/MCBs in your fuse box/distribution board.
▶ Open windows and doors.

The safety equipment also switches off the DHW heating. If the dual mode point is undershot, the emergency/booster heater for DHW heating switches on, resulting in an increased electrical energy demand.

3. Appliance description

The appliance comprises a function module and a cylinder module that are supplied as separate shipping units. The wider module with the air hose connections in the cover is the function module.

The components required for installation are in a separate carton inside the function module packaging.

3.1 Standard delivery



Material losses

Never install the push-fit connectors in the DHW line. Never install the push-fit connectors to the solar flow or solar return connections. Only install the push-fit connectors in the heating circuit.

The following are delivered with the appliance:

- Operating instructions

- Installation instructions
- Notification list
- Transport aid, comprising two angled brackets with screws for fixing to the appliance
- Programming unit
- Outside sensor
- Four adjustable feet for the cylinder module
- Eight sliding blocks for easier positioning of the appliance
- Hose clips to secure the air hoses
- Adhesive tape to seal the inner hose to the hose connector
- PE plate for connection to a geothermal heat exchanger or an external fresh air intake
- Fixing materials (screws, washers, etc.)
- Two straight push-fit connectors for the hydraulic connection of the function and cylinder modules

For connection to the heating circuit:

- Two straight push-fit connectors
- One filter ball valve
- One ball valve
- Two 90° push-fit connectors
- Four straight pieces of pipe with G 1 union nut

3.2 Required accessories

- Air hose with thermal insulation, 4 m
- Thermally insulated wall outlet with external wall grille

3.3 Additional accessories

- Additional programming unit with wall mounted casing
- Spare filter set
- Diverter hood (enables the appliance to be sited in rooms with head heights between 2.2 and 2.5 m)
- Silencer DN 315
- Segmented anode
- DHW circulation pipe set
- Filter box (for installation in round DN 160 ventilation pipes)
- ISG: Internet Service Gateway
- PK 10: Condensate pump
- Safety temperature controller for underfloor heating system
- Temperature sensor for the second DHW cylinder (sensor type Pt1000)
- ZKA WP: Condensate drain with outlet siphon

3.4 Appliance functions

The supply air fan induces outdoor air into the appliance. The extract air fan draws stale air from the living areas into the appliance. Outdoor air and extract air are routed through particle air filters into separate ducts of a cross-countercurrent heat exchanger. Inside the cross-countercurrent heat exchanger, the outdoor air is heated and channelled into the living space as supply air. The extract air cools down inside the cross-countercurrent heat exchanger and is routed as exhaust air first through the evaporator and then outdoors.

The cross-counter-current heat exchanger ensures that up to 90 % of the heat in the extract air is returned with the supply air into the living space.

In addition, heat is extracted from the outdoor air by means of an air source heat pump. The energy extracted from the outdoor air in the evaporator is transferred via the condenser to the central heating or DHW system.

In the case of low outside temperatures or high heat demand from the central heating or DHW heating systems, the additional heat demand is covered by an electric emergency/booster heater.

3.4.1 Utilising solar energy

A solar heat exchanger is integrated into the appliance. You can connect a solar thermal system to this coil by means of the appliance solar flow and solar return connections. Solar backup can be provided both in central heating mode and DHW mode. A differential temperature controller for the solar thermal system is integrated in the appliance control unit.



Material losses

In some operating situations, the solar circuit pump will be operated cyclically.

3.4.2 Cooling

The refrigeration unit of the heat pump may be reversed. In cooling mode, heat may be extracted from the heating circuit and transferred to the outdoor air.

For cooling we recommend separating the streams of the heating circuits and those of the appliance. We also recommend installing a buffer cylinder. The buffer cylinder must be suitable for cooling, i.e. the buffer cylinder must be insulated against vapour diffusion.

Cooling without buffer cylinder is only possible if a coordinated heating system with a sufficiently high flow rate and adequate cooling draw-off is installed. See „Min. flow rate, cooling (without buffer cylinder)“ and „Min. living area, active cooling (without buffer cylinder)“ in chapter „Specification / Data table“.

If cooling is delivered via the underfloor heating system, both underfloor heating system and actuators must be suitable for cooling. It must be possible to connect a cooling signal, so that the minimum cooling area is always opened for cooling.

If cooling is delivered by means of fan convectors, these must have a sufficiently high rating. The minimum flow rate must be ensured.

The minimum flow rate for cooling must not be ensured by means of the overflow valves; instead it must be ensured via the heating circuits.

The „COOLING“ menu will only be activated when connecting an external programming unit. The menu is only visible on the external programming unit. During commissioning, the external programming unit must be assigned to the heating circuit. Active cooling is impossible without an external programming unit. Only the programming units with selected terminal address 1 or 2 transmit temperature and humidity values to the appliance controller.

When activating cooling mode, assign the type of heat transfer to the heating circuits that will be active during cooling.

- Area cooling means: underfloor heating systems, wall heating systems and generally all heating systems that have no means of draining any condensate. The set flow temperature of at least 18 °C will only be enabled if the relative humidity in the room permits this. Otherwise the flow temperature will be limited. An operative programming unit with terminal address 1 or 2 must be provided for every heating circuit with area cooling, otherwise that circuit will be disabled.
- Fan convector means: Fan convectors or other heating/cooling elements that have a facility for collecting condensate and draining it to a specific place. Thermally insulate heating pipes with vapour diffusion-proof material. The flow temperature must be at least 7 °C.



Material losses

If for area heating systems radiators or convectors without condensate drain setting „FAN CONVECTORS“ is selected in the „COOLING SYSTEM“ menu, there would be a risk of severe moisture-related damage through condensation.

Conventional thermostatic valves are closed when cooling is required. Cooling will be possible when the thermostatic or zone valves are set to cooling, provided they offer such a function. Alternatively, these valves may also be opened via the cooling signal (XD03, „Cool“ output). Temporarily, valves may also be opened fully for cooling.

Cooling is not possible in manual mode.

Cooling function

Parameter „COOLING MODE“ must be set to „ON“. Cooling is enabled when the appliance is in summer mode and the outside temperature exceeds the set room temperature for heating (parameter „ROOM TEMPERATURE DAY“ in menu „HEATING / ROOM TEMPERATURES HC1“ or „ROOM TEMPERATURES HC2“) for 2 hours by 3 K.

If the room temperature is then higher by the value set under „HYST. ROOM TEMP.“ than the set room temperature for cooling (parameter „ROOM TEMPERATURE DAY“ in menu „COOLING / ROOM TEMPERATURES HC1“ or „ROOM TEMPERATURES HC2“), then the system prepares for cooling. The display shows a snowflake. The circulation pump starts, the three-way valve changes over to the heating circuit and the „cooling“ output is activated in order to, for example, open the thermostatic valves in the rooms to be cooled.

The compressor starts if the flow temperature lies higher than the set flow temperature for cooling by the amount of flow temperature hysteresis. The compressor stops when it is lower than this by the amount of flow temperature hysteresis.

The dew point is monitored in area heating systems. The dew point is that temperature at which humidity in the air begins to condensate. The compressor stops once the flow temperature is within 2 K of the dew point. The compressor will be enabled if it lies above this value by the hysteresis set in parameter „HYST. FLOW TEMP.“.

INSTALLATION

Preparation

3.4.3 Frost protection for the cross-countercurrent heat exchanger

A heat exchanger in the path of the outdoor air flow preheats the outdoor air, and thus prevents the cross-countercurrent heat exchanger from freezing up.

3.4.4 Buffer mode for air heating

If a heating system with a low draw-off rate and little thermal capacity is used, e.g. air heating coil through which the domestic ventilation flow is routed, the lower section of the DHW cylinder can be utilised as a buffer cylinder. Excess heat can be temporarily stored there, thereby reducing compressor cycling. This function can be activated in the „DHW“ menu using the „DHW BUFFER MODE“ (P84) parameter.

You can determine the operating mode by positioning the cylinder temperature sensor.

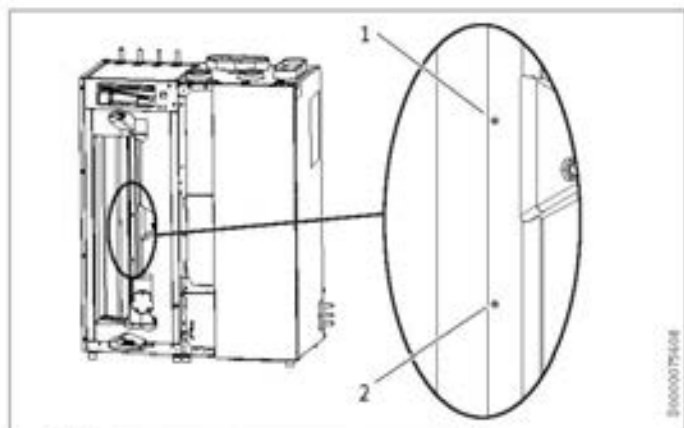

- 1 Cylinder temperature sensor - upper position
- 2 Cylinder temperature sensor - lower position

If the cylinder temperature sensor is in the upper position, approx. 100 l water are always maintained at the required DHW temperature. The remaining cylinder capacity is used as a heating water buffer and have a temperature corresponding to the heating flow temperature.

If the cylinder temperature sensor is in the lower position, the entire cylinder content is always maintained at the required DHW temperature.

4. Preparation

4.1 Installation site

To be able to open the front door freely, maintain a minimum clearance on the r.h. side and in front of the appliance. The required room height depends on whether the reversing hood is used or whether the hoses are connected directly (see chapter „Installation site / Minimum clearances“). Maintain a minimum clearance on the r.h. side of the appliance for service work.

Never install the appliance in wet rooms.

The room in which the appliance is to be installed must meet the following conditions:

- The room must be free from the risk of frost.
- The floor must have sufficient load bearing capacity. In addition to the appliance weight, also take that of the cylinder content into account.
- The substrate must be horizontal, level, solid and permanent.
- When installing the appliance inside a boiler room ensure that the boiler operation is not impaired.
- The quantity of refrigerant makes it necessary to observe the minimum volume of the installation room (see chapter „Specification / Data table“).



Material losses

The installation room floor must be water resistant. During appliance operation, the outdoor air releases up to 50 l of condensate per day. In the case of deficient or inadequate maintenance, water may escape. We recommend installing a drain in the floor of the installation room.

4.1.1 Minimum clearances

Outdoor/exhaust air connection with diverter hood

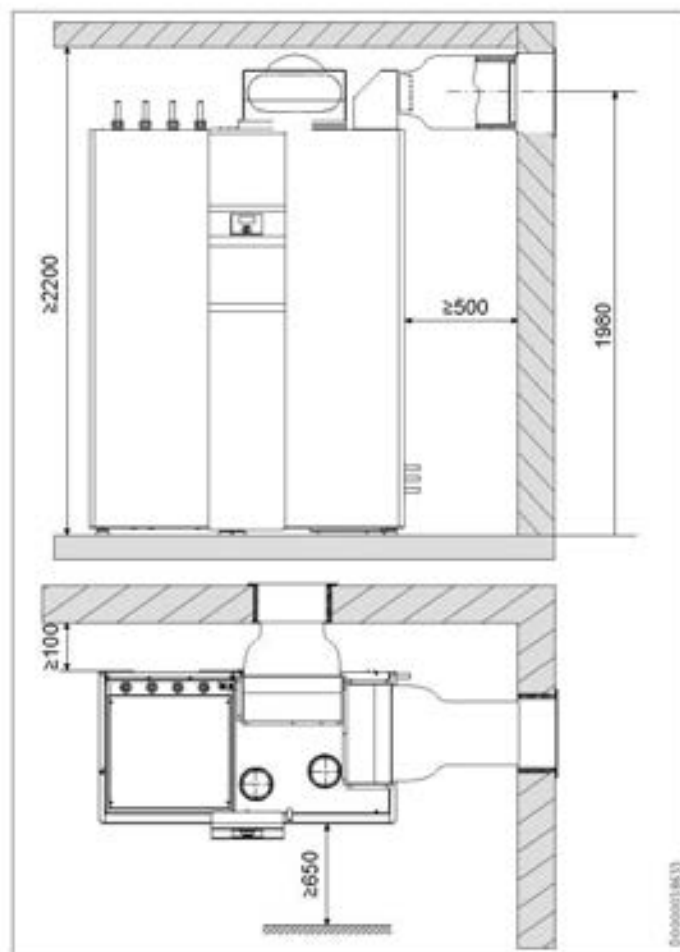

INSTALLATION

Preparation

Outdoor/exhaust air connection with air hose

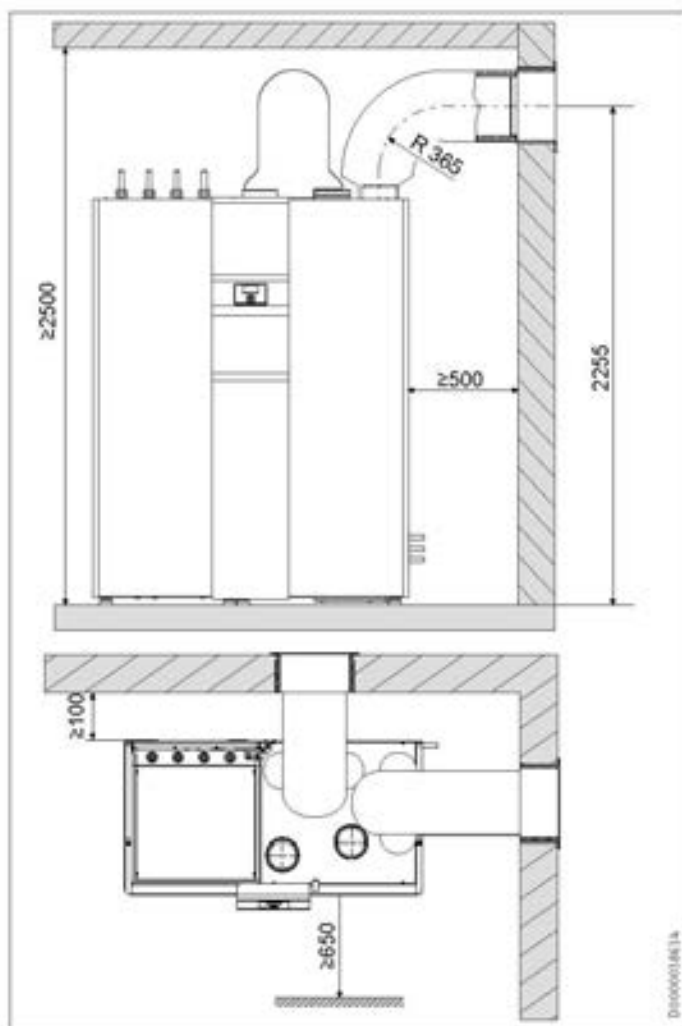

Connecting outdoor air to geothermal heat exchanger

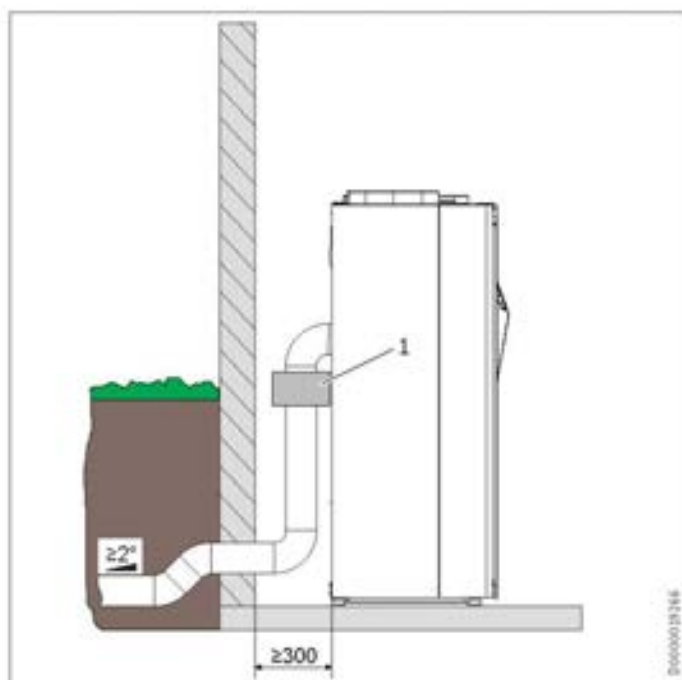

1 Filter box

Outdoor air mechanical ventilation connection option

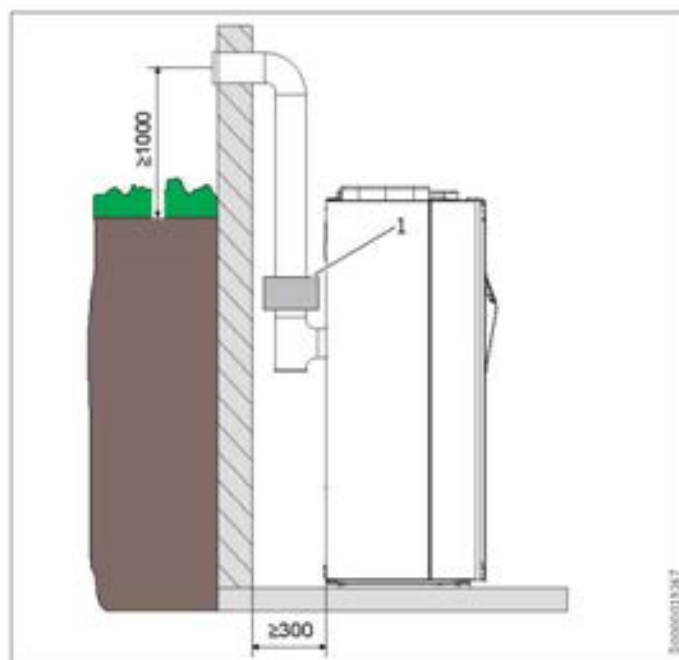

1 Filter box

4.2 Air routing

Prevent air stream „short circuits“. The air intake and discharge apertures in the external walls should be arranged around corners. When installing the air intake and discharge apertures on the same side of the building, maintain a minimum clearance of at least 2 m between apertures. Where that is impossible, create a separation between the air streams, e.g. by a separating wall or shrubs between the intake and discharge apertures.

Never align the apertures toward neighbouring living room or bedroom windows.

4.3 Sound emissions

Sound insulation for rooms adjacent to the installation room

The appliance is quiet in normal operation. When operating at its application limits under full load, sound emissions can occur due to the power density. These sound emissions may cause a disturbance in neighbouring rooms. This is especially the case if the installation room adjoins a living room or bedroom. To prevent noise pollution, sound attenuation measures are necessary, e.g. sound attenuation of a higher standard for the internal wall. Pipe fixings and wall outlets must have structure-borne noise attenuation. For the wall between the installation room and the living space, we recommend a wall structure that ensures the following sound-absorbing coefficient:

- 45 dB(A) for adjacent living rooms and bedrooms
- 40 dB(A) for other rooms

Doors should be of noise protection class SK 3.

If the unit backs onto an adjacent room, we recommend the following sound-absorbing coefficient:

- 55 dB(A) for adjacent living rooms and bedrooms
- 50 dB(A) for other rooms

A passage to the neighbouring room is not recommended.

INSTALLATION

Preparation

The floor between the installation room and living areas must have carefully applied anti-vibration separation. Ensure that no pipes are routed on or in the wall and that the air ducts have anti-vibration separation.

If the unit installation room is included in the building ventilation system, the design must include an extract air vent and supply air vent for this room. To avoid the need for an overflow aperture in the door, the supply air and extract air flow rates must be balanced.



Note

The unit can seem loud if operated in an unfinished building without doors. This is because the fixtures and fittings which will provide sound attenuation are not yet in place: once the building is occupied this should no longer occur.

Sound attenuation measures 45 dB(A)

A sound-absorbing coefficient of 45 dB(A) can be achieved using, for example, a wall of lightweight, timber frame construction with full insulation. The cross-section of the timber supports should be 60 x 60 mm. The wall must have plasterboard panelling on both sides, with a thickness of 12.5 mm on one side and 10 mm on the opposite side.

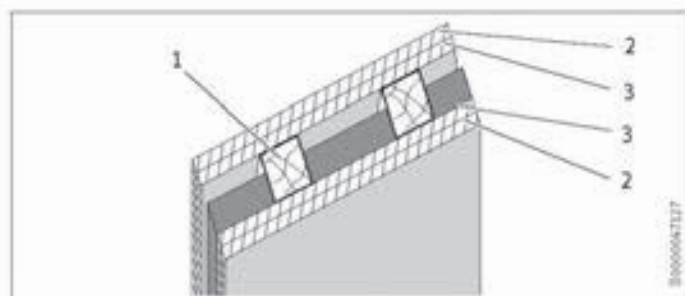

- 1 Timber frame supports 60 x 60 mm
- 2 Gypsum fibre board 12.5 mm
- 3 Gypsum fibre board 10 mm

Sound attenuation measures 55 dB(A)

A sound-absorbing coefficient of 55 dB(A) can be achieved using, for example, a twin wall of lightweight, timber frame construction with full insulation and 30 mm parting line. The cross-section of the timber supports should be 60 x 60 mm. The wall must have 12.5 mm plasterboard panelling on both sides.

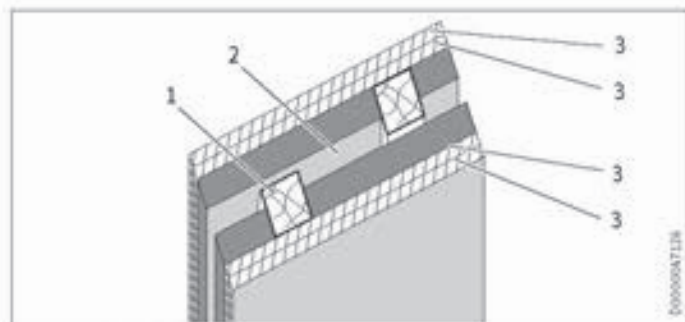

- 1 Parting line 30 mm
- 2 Timber frame supports 60 x 60 mm
- 3 Gypsum fibre board 12.5 mm

Anti-vibration separation

With the anti-vibration feet, it is possible to install the appliance on floating screed, as long as this has been applied correctly. If necessary provide separation.

If the appliance is positioned on a wooden beam ceiling, you must take special steps to prevent structure-borne noise transmission.

Installation on foundations

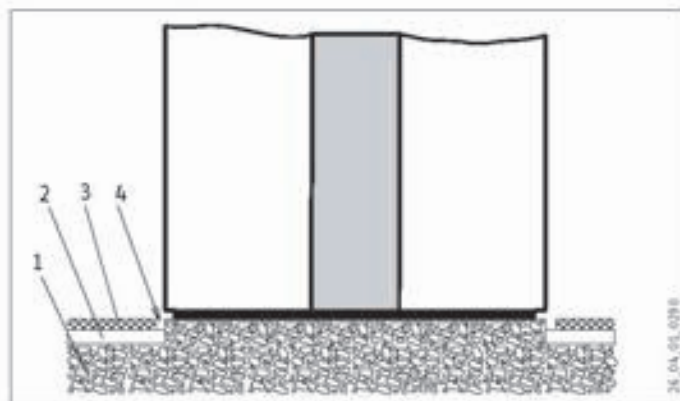

- 1 Concrete base
- 2 Impact sound insulation
- 3 Floating screed
- 4 Screed recess

The separation can also be made later, by cutting the screed all the way around the appliance.

Installation on screed with impact sound insulation

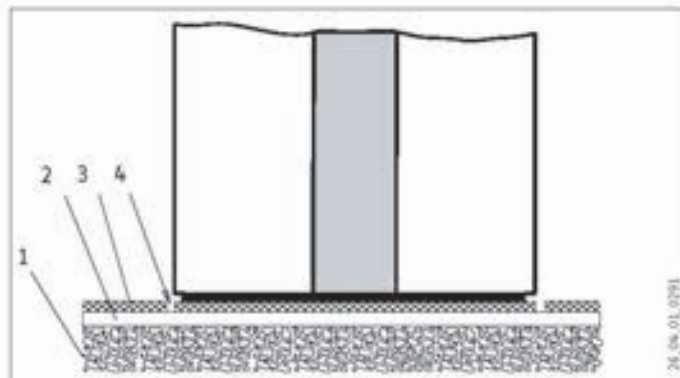

- 1 Concrete base
- 2 Impact sound insulation
- 3 Floating screed
- 4 Screed recess

► Protect all pipe fixings and wall transitions with anti-vibration insulation.

INSTALLATION

Preparation

4.4 Electrical installation

Permission must be obtained from your local power supply utility.



WARNING Electrocutation

Carry out all electrical connection and installation work in accordance with national and regional regulations.



WARNING Electrocutation

The appliance contains inverters (e.g. variable speed compressors, high efficiency circulation pumps or high efficiency fans). In the event of a fault, inverters can cause DC residual currents. If RCDs are provided, they have to be type B AC/DC-sensitive.

A DC residual current can block type A RCDs.

- ▶ Ensure that the appliance power supply is disconnected from the distribution board.

Electrical data is provided in the chapter „Specification / Data table“.

All electrical connection and installation work must be carried out in accordance with VDE regulations (DIN VDE 0100) [or local regulations], the rules of your local power supply utility, and relevant national and local regulations.

The cable cross-section must be designed for the maximum possible operating current of the appliance (see „Specification/Data table“).



Note

Route the power cables and control cables separately.



Note

Provide separate fuses for the power circuits for the appliance, the electric emergency/booster heater and the control unit.

4.5 Oxygen diffusion



Material losses

Do not use open vented heating systems. Use oxygen diffusion-proof pipes in underfloor heating systems with plastic pipework.

In underfloor heating systems containing permeable plastic pipes, or in open vented heating systems, oxygen diffusion can cause corrosion to the steel components of the indirect coil in the DHW cylinder, steel radiators or steel pipes.



Material losses

The products of corrosion (e.g. rusty sludge) can settle in the heating system components, which may result in a lower output or fault shutdowns due to reduced cross-sections.

4.6 Transport



Material losses

If the appliance is transported without packing and without using a pallet, its outer casing may be damaged. Remove the side panels and doors in such cases.

4.6.1 Function module

To protect the appliance against damage, transport it vertically inside its packaging. Where space is restricted, you can also tilt the appliance at an angle to move it.

To make handling easier, you may attach a transport aid on the back of the function module. This comprises two angled brackets.

- ▶ Fit one angle bracket each vertically on the l.h. and r.h. side.



1 Transport aid

- ▶ Slide a robust pipe through the holes inside the transport aids to create a handle.
- ▶ The transport aid can also be used in connection with a crane/hoist to transport the appliance to the installation location.

4.6.2 Cylinder module



Material losses

During transport, never hold the cylinder module by its connection pipes, as these would bend out of shape.



Note

We recommend the transport of the cylinder module on its pallet to the installation location. The pallet offers more places to hold than the cylinder module casing.

There are two grip recesses at the top of the back panel.

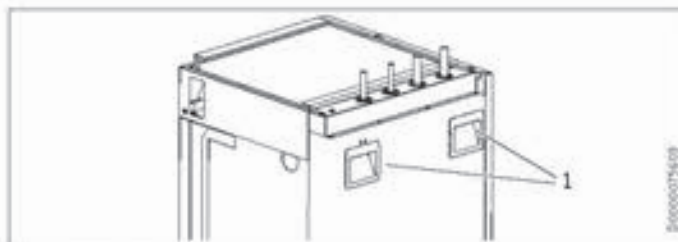

1 Recessed grips

5. Installation

5.1 Siting the function module



Material losses

Never tilt the appliance excessively. Contacts between the casing and the floor can damage the paintwork.

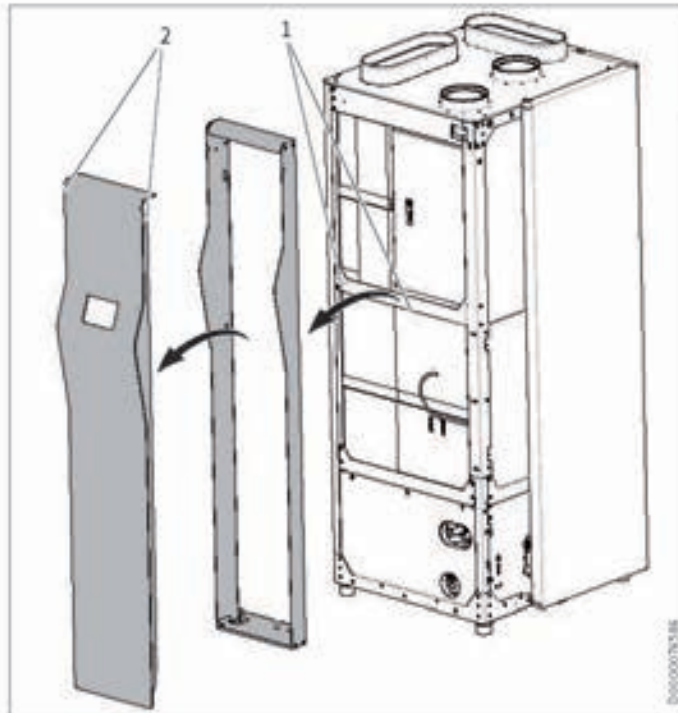

- 1 Support screws of the fascia framework
- 2 Fascia fixing screws

The fascia and fascia frame that are fitted to the front of the appliance later, hang for shipping from the factory on the l.h. side of the function module.

- ▶ Lift the fascia frame slightly and remove the fascia from the function module.
- ▶ Undo both support screws from which the fascia was hung from the lateral cross bar of the function module. If these support screws are not removed they would be in the way when pushing the function and cylinder modules together and securing them with screws. Put the support screws aside and use one of these later to secure the fascia frame to the appliance.
- ▶ Undo both lateral fascia fixing screws with which it is secured to the fascia frame.
- ▶ Pull the fascia slightly upwards and then forwards out of the fascia frame.
- ▶ Remove the wooden braces secured to the pallet which prevented the appliance from slipping during shipping.
- ▶ Open the function module door.

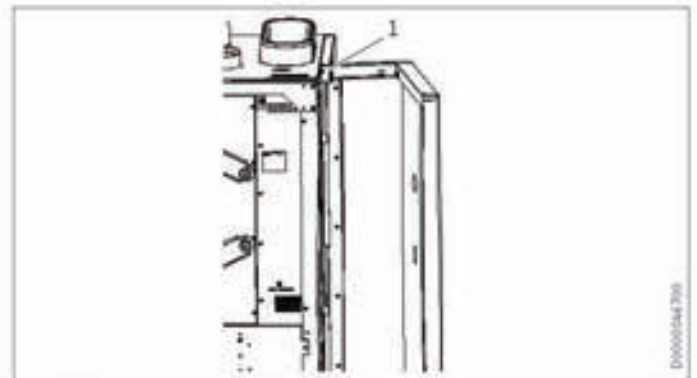

- 1 Fixing screw on the r.h. side panel

- ▶ At the top of the gap between door and appliance, undo the fixing screw for the r.h. side panel.
- ▶ Carefully push the the r.h. side panel up and remove the side panel from the appliance.

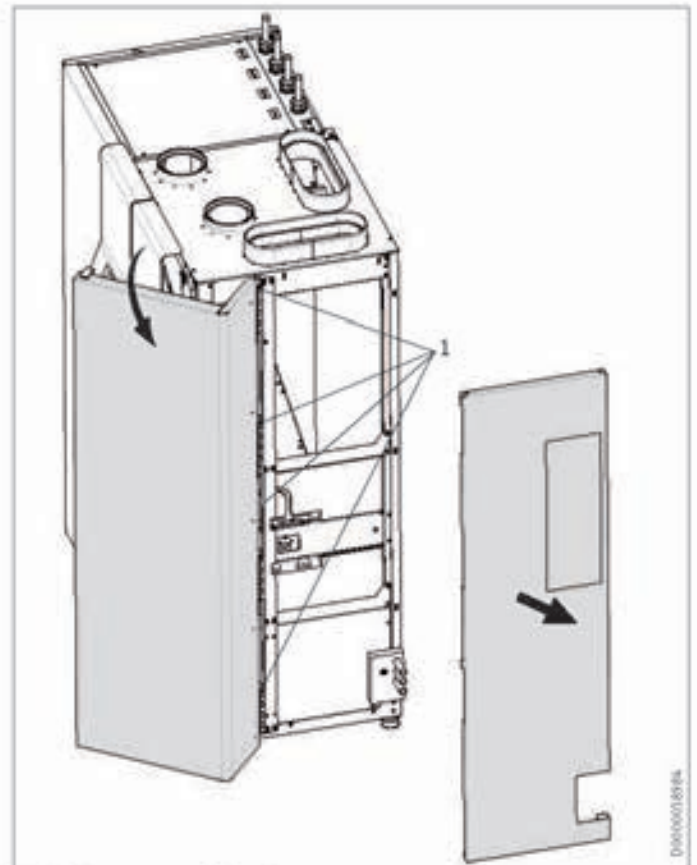

- 1 Fixing screws of the door

- ▶ Undo the fixing screws of the door.
- ▶ Remove the door.
- ▶ Remove the function module carefully from the pallet.
- ▶ Push the sliding blocks supplied under the adjustable feet, so the function module can be moved more easily to the required position.
- ▶ Remove the sliding blocks once the appliance is in its intended location.

INSTALLATION

Installation

Outdoor air mechanical ventilation connection option



Note

Observe the minimum clearance at the back of the appliance. See chapter "Preparations / Installation site / Minimum clearances".

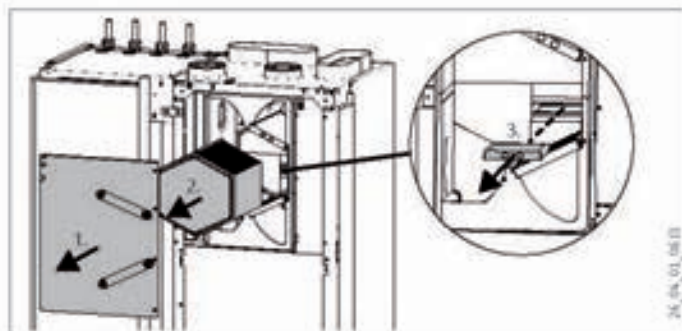

- 1 Upper front panel
- 2 Cross-countercurrent heat exchanger
- 3 Outdoor air filter cassette

- ▶ Remove the upper front panel.
- ▶ Undo the screws on the cover which seals off the outdoor air mechanical ventilation option port on the back of the function module.
- ▶ Remove the cover.



- ▶ Using wire cutters, cut through the spacers of the knock-out aperture on the back panel of the function module.

The EPS insulation becomes visible once the knock-out panel has been removed.

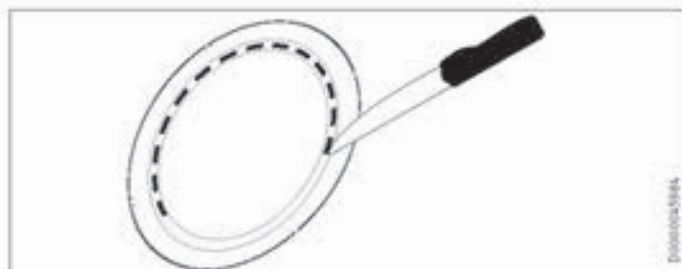

Material losses

The heat exchanger situated behind the EPS insulation must not be damaged.

- ▶ Never cut in the bottom third of the circular groove sketched out on the EPS insulation.
-
- ▶ Using a knife, carefully cut along the upper two-thirds of the dotted groove marked out on the EPS insulation.

- ▶ Press the core piece inward, carefully break it out and remove it.
- ▶ Smooth out the line of breakage.
- ▶ Clean the aperture.
- ▶ Push the folded spiral-seam tube through the hole (max. 30 mm deep).
- ▶ Seal the gap between the folded spiral-seam tube and the EPS insulation with sealing tape.
- ▶ Pull out the cross-countercurrent heat exchanger.
- ▶ Grasp the outdoor air filter cassette by the grip holes and pull it out.
- ▶ Push the plate supplied into the appliance in place of the outdoor air filter cassette.



Note

Fit a filter in the outdoor air duct to replace the internal outdoor air filter that was removed previously. An air filter box with coarse particle filter mat is available as an accessory.

Fit the joining bracket at the back at the bottom

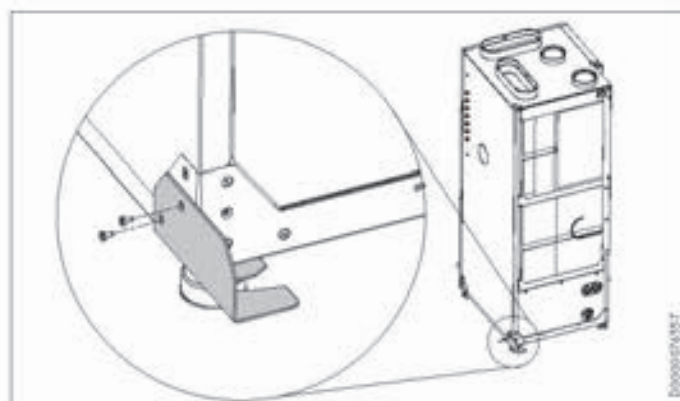

- ▶ Insert the joining bracket at the rear l.h. adjustable foot of the function module between the appliance floor and the adjustable foot. Secure the joining bracket with two screws to the back panel of the function module.
- ▶ Level the function module vertically by turning the height-adjustable feet.

INSTALLATION

Installation

5.2 Installing the cylinder module

- ▶ Undo the screws underneath the pallet with which the cylinder module is secured to the pallet.



Material losses

Never tilt the cylinder module excessively. Contacts between the casing and the floor can damage the paintwork.

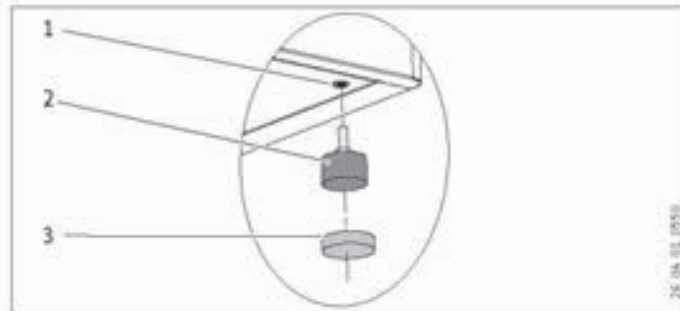

- 1 Captive nut on the bottom of the cylinder module
- 2 Adjustable foot with nut for fitting with an open-ended spanner
- 3 Sliding block

- ▶ Carefully tip the cylinder module far enough to enable the adjustable feet to be inserted.
- ▶ Insert the adjustable feet into the captive nuts with which the cylinder module was previously secured to the pallet.
- ▶ Remove the cylinder module carefully from the pallet.
- ▶ Push the sliding blocks supplied underneath the adjustable feet.
- ▶ Level the cylinder module vertically by turning the height-adjustable feet. Arrange the bottom panel so that it is 4 to 5 mm higher than the bottom panel of the function module. This is the amount by which the cylinder module drops when it is being filled with water.



Note

The adjustable feet must not be fully screwed in, otherwise you will not be able to push the joining bracket between the bottom panel and the foot.

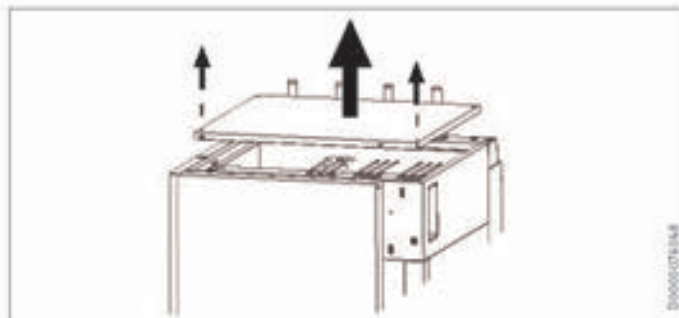

- ▶ Undo the cover screws on the cylinder module.
- ▶ Reach through the port on the r.h. side of the cylinder module and push the cylinder module cover upwards.
- ▶ Remove the cylinder module cover.

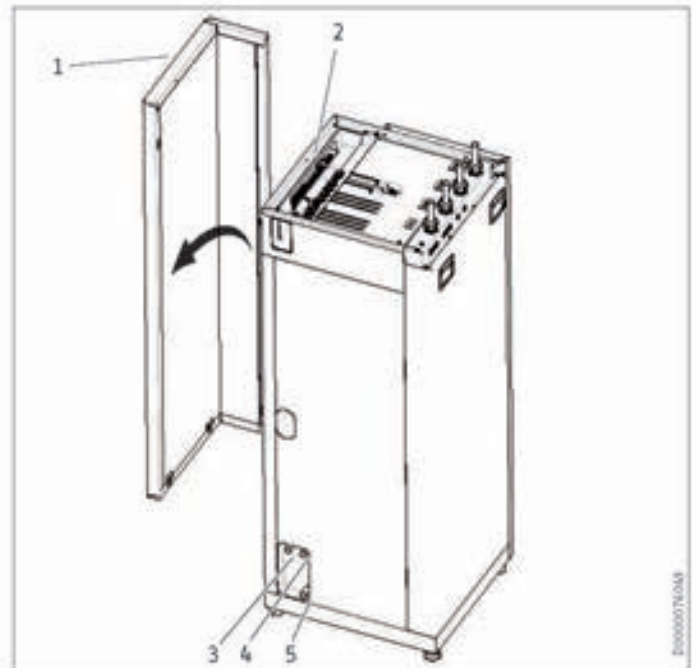

- 1 Front panel of the cylinder module
- 2 Screw for securing the front panel
- 3 DHW flow
- 4 Heating flow
- 5 Common return

- ▶ Lift the front panel of the cylinder module slightly and remove it from the cylinder module.
- ▶ Remove the protective caps from the three pipes (DHW flow, heating flow, common return); these are located in the lower section on the r.h. side of the function module. Later on, these pipes connect the function module and cylinder module hydraulically.



Note

The pipes must protrude at least 40 mm. If necessary, remove any protruding foam insulation.

Removing the side panel of the cylinder module (optional)

The side panel of the cylinder module only needs to be removed if you want to install the DHW circulation set available as an accessory.

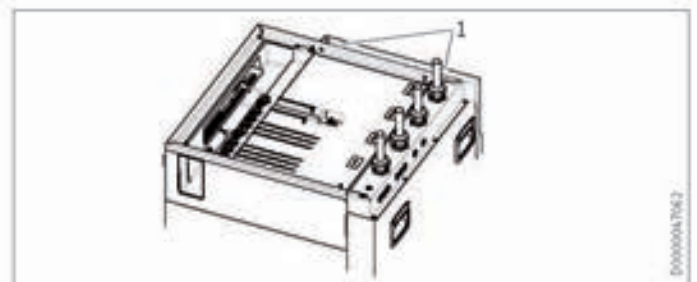

- 1 Screw for securing the side panel
- ▶ Undo the screws securing the side panel.
 - ▶ Lift the side panel slightly and remove it from the cylinder module.

INSTALLATION

Installation

Pushing the cylinder module towards the function module

- ▶ Push the cylinder module carefully towards the function module, so that the rear r.h. adjustable foot of the cylinder module is near the recess in the joining bracket.

5.3 Connecting modules

Cylinder temperature sensor and anode cable

- ▶ Remove the cable tie that tie together the electrical cables of the anode terminal and the cylinder temperature sensor lead.
- ▶ Pull the connecting cables/leads of the anode and the cylinder temperature sensor through the aperture located on the top r.h. side in the cylinder module.

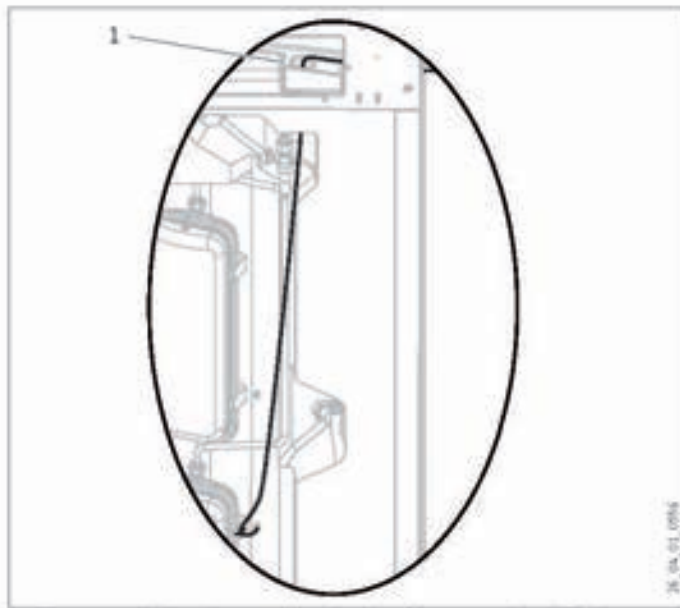

- 1 Aperture in the thermal insulation for sensor lead of the cylinder temperature sensor
- ▶ Push the cylinder temperature sensor from the top through the aperture in the thermal insulation.
 - ▶ Insert the cylinder temperature sensor into the lower cylinder sensor well.

Note
It is possible that the cylinder module and the function module will still be too far apart to be able to insert the cylinder temperature sensor into the sensor sleeve. If so, you can insert the cylinder temperature sensor into the sleeve at a later point. What is important is that you route the sensor lead through the insulation before you install the terminal bracket.

The top sensor sleeve is required either in connection with buffer operation on convector heaters (see chapter „Settings / DHW / DHW buffer mode“) or for economy mode (see chapter „Connecting internal cables“).

Pushing the cylinder and the function modules together

Note
An air hose to capture the differential pressure runs along the l.h. side of the function module. This air hose must run inside the curved groove cut into the thermal insulation.
▶ Ensure that this air hose is seated correctly.

Note
The adjustable feet must not be fully screwed in, otherwise you will not be able to push the joining bracket between the bottom panel and the foot.

- ▶ Push the cylinder module further towards the function module, so that the rear r.h. adjustable foot of the cylinder module is pushed into the recess in the joining bracket.

The lower joining bracket ensures that the cylinder module is automatically pushed into its final position.

- ▶ Level the cylinder module and the function module vertically to the same height by turning the adjustable feet.

Note
The cylinder module drops 4 to 5 mm when its cylinder is filled.

Turning anti-clockwise exposes more of the adjustable feet, meaning the appliance moves upwards. The cylinder module must be snug against the function module.

Connection top back

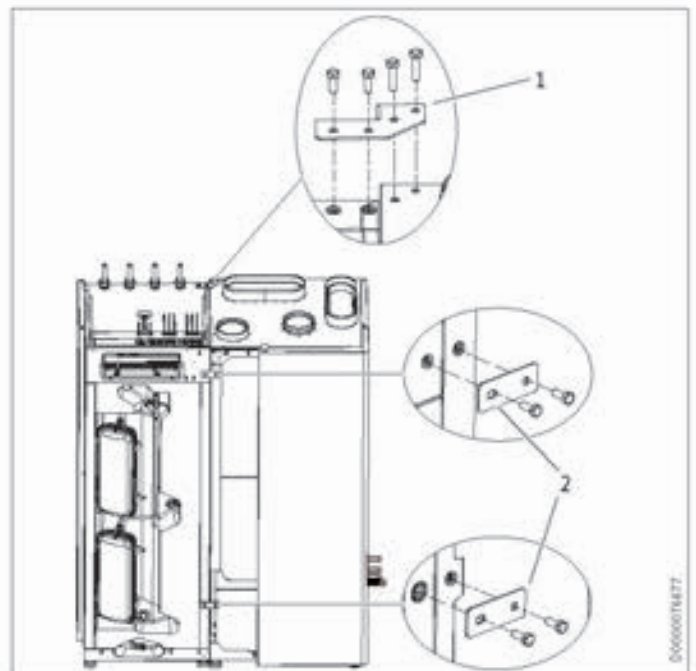

- 1 Joining plate
 - 2 Horizontal locking bracket
- ▶ Connect the function module and the cylinder module at the top back by positioning joining plate and inserting two screws each through the joining plate into the function module and the cylinder module.

INSTALLATION

Installation

Fitting the horizontal locking bracket to the front

- ▶ Connect the function module and cylinder module at the front by securing one horizontal locking bracket each at the top and bottom using screws.



Material losses

Before filling, tighten the screws only lightly so that the paint finish is not damaged when the cylinder module moves down during filling. Tighten the screws after filling.

Connecting the function module and the cylinder module hydraulically

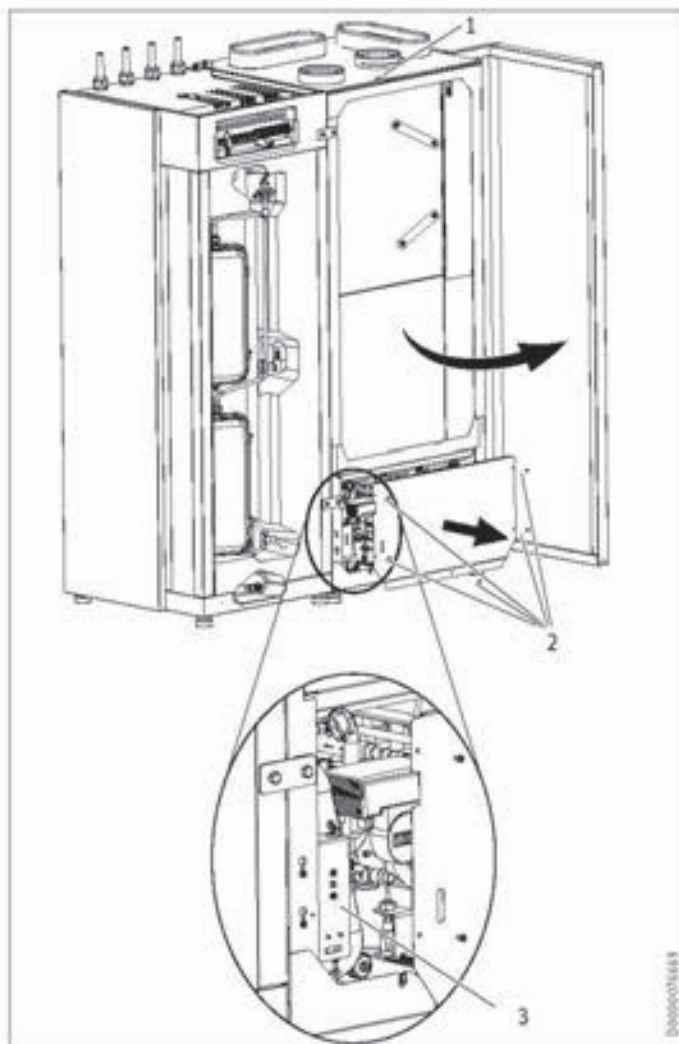

- 1 Door lock
- 2 Fixing screws of the lower front panel
- 3 High limit safety cut-out retaining bracket

A door lock is located above the door of the function module.

- ▶ Push the door lock at the front upwards.
- ▶ Pull the door lock backwards and then upwards to unhook the door lock.
- ▶ Open the function module door.
- ▶ Undo the fixing screws from the lower front panel.
- ▶ Remove the lower front panel.

To make yourself room for the assembly, you can temporarily unhook the high limit safety cut-out retaining bracket.

- ▶ Undo the screws on the high limit safety cut-out retaining bracket.
- ▶ Unhook the high limit safety cut-out retaining bracket from the slots, pull it out of the appliance and hook it into the same slots, but this time from the outside.

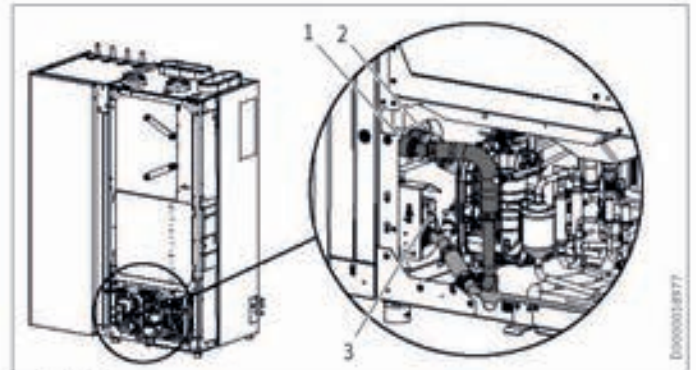

- 1 DHW flow
- 2 Heating flow
- 3 Common return

The hydraulic connection between the function and cylinder module is provided by three pipes: DHW flow, heating flow and common return.

- ▶ Make sure that the caps have been removed from the pipes.

5.3.1 How the push-fit connectors work



Material losses

Never install the push-fit connectors in the DHW line. Never install the push-fit connectors to the solar flow or solar return connections. Only install the push-fit connectors in the heating circuit.



Material losses

Tighten the screw cap of the push-fit connector by hand. Never use a tool.



Material losses

To ensure the push-fit connector is held securely, pipes with a surface hardness > 225 HV (e.g. stainless steel) must have a groove.

- ▶ Using a pipe cutter, cut a groove (depth approx. 0.1 mm) at a defined distance from the end of the pipe.

- Pipe diameter 22 mm: 17±0.5 mm
- Pipe diameter 28 mm: 27.5±0.5 mm



Material losses

Support sleeves are required when using plastic pipes.

The push-fit connectors are equipped with a retainer with stainless steel serrations and an O-ring for sealing. The push-fit connectors also have a „twist and secure“ function.

Simply turning the screw cap by hand will secure the pipe in the connector and push the O-ring against the pipe to seal it.

INSTALLATION

Installation

Making the push-fit connection

The connector must be in its relaxed position before the pipe is inserted. In this position, there is a small gap between the screw cap and connector body.

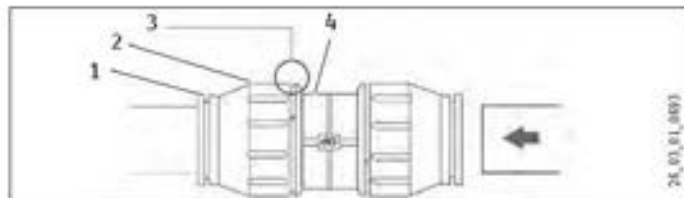

- 1 Retainer
- 2 Screw cap
- 3 Gap between screw cap and connector body
- 4 Connector body

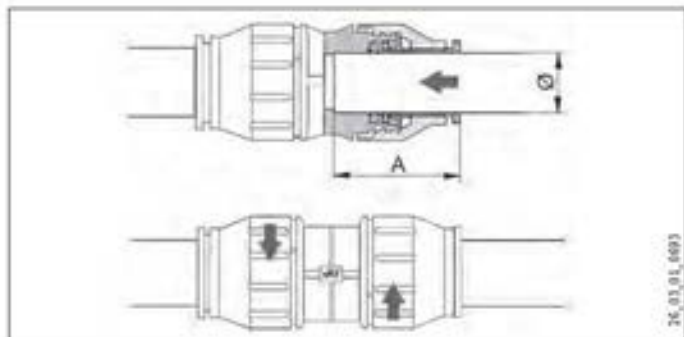

Ø	Pipe diameter	mm	22
A	Insertion depth	mm	38



Material losses

- Pipe ends must be deburred.
- ▶ Always use a pipe cutter to trim pipes.

- ▶ Push the pipe past the O-ring into the push-fit connector until it reaches the prescribed insertion depth.
- ▶ Tighten the screw cap fully to the joiner body until finger-tight. This secures the push-fit connection.

Undoing the push-fit connection

If the push-fit connectors later need to be undone, proceed as follows:

- ▶ Turn the screw cap anti-clockwise until there is a narrow gap of approx. 2 mm. Press the retainer back with your fingers and hold on to it.
- ▶ Pull out the inserted pipe.

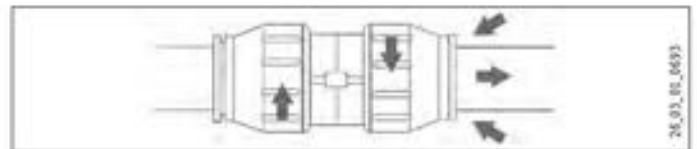

5.3.2 Fitting the push-fit connectors

An elbow push-fit connector is prefitted on the heating flow in the function module.

- ▶ Fit the elbow push-fit connector onto the heating flow port on the r.h. side of the cylinder module.
- ▶ Push a straight push-fit connector on each of the two pipes on the r.h. side of the cylinder module.
- ▶ Connect both of the free pipes inside the function module to the push-fit connectors that you previously attached to the cylinder module pipes.
- ▶ Refit the high limit safety cut-out retaining bracket from the inside using the slots and secure the bracket.

5.4 Heating water connection

The heating system must be connected by a qualified contractor in accordance with the water installation drawings, which are part of the technical guides. You can use the push-fit connectors supplied or ball valves to make the connection of the flow and return.



Note

Deburr the pipe ends.

A filter ball valve is provided for the return. Two union nuts and two short flanged copper pipe ends are provided for fitting a ball valve.

- ▶ As a suitable point, install an air vent valve at the highest point of the heating system.
- ▶ Thoroughly flush the pipework before connecting the appliance. Foreign bodies such as welding pearls, rust, sand, sealant, etc. can impair the operational reliability of the appliance, and can lead to the condenser becoming blocked.
- ▶ Remove the protective caps from the heating flow and heating return connections.

INSTALLATION

Installation

„Heating return“ connection

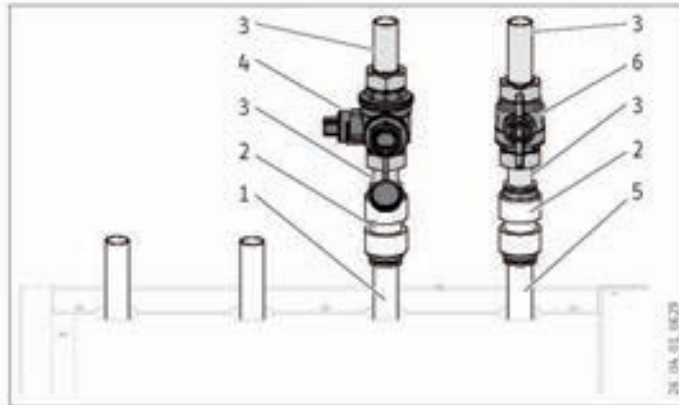

- 1 „Heating return“ connection
- 2 Plug-in connector
- 3 Flanged pipe
- 4 Filter ball valve
- 5 „Heating flow“ connection
- 6 Ball valve

- ▶ Using a push-fit connector, connect one of the flanged pipes supplied to the heating return connection.
- ▶ Connect the filter ball valve to the flanged pipe end.
- ▶ Reconnect a flared pipe to the end of the ball valve.
- ▶ Connect the flanged pipe with a push-fit connector to the heating circuit return.

„Heating flow“ connection

- ▶ Using a push-fit connector, connect one of the flanged pipes supplied to the connection for the heating flow.
- ▶ Connect a ball valve to the flanged pipe end.
- ▶ Connect a flanged pipe to the other side of the ball valve.
- ▶ Connect the flanged pipe with a push-fit connector to the heating circuit flow.

Thermal insulation

- ▶ Provide thermal insulation in accordance with current regulations.

Water quality

Carry out a fill water analysis before filling the system. This may, for example, be requested from the relevant water supply utility.

To avoid damage as a result of scaling, it may be necessary to soften or desalinate the fill water. The fill water limits specified in chapter „Specification / Data table“ must always be observed.

- ▶ Recheck these limits 8-12 weeks after commissioning and as part of the annual system maintenance.



Note
With a conductivity > 1000 µS/cm, desalination treatment is recommended in order to avoid corrosion.



Note
If you treat the fill water with inhibitors or additives, the same limits apply as for desalination.



Note
Suitable appliances for water softening, as well as for filling and flushing heating systems, can be obtained via trade suppliers.

Minimum flow rate

The appliance is designed in such a way that no buffer cylinder is required to provide hydraulic separation of the flow in the heat pump circuit and the heating circuit in conjunction with area heating systems. If several heating circuits are used, we recommend using a low loss header.



Note
The minimum flow rate must be maintained at every operating point of the heat pump to ensure perfect heat pump operation (see „Commissioning / Commissioning“). To do this, the following options are available:

- ▶ Install a remote control in a lead room and open this heating circuit fully.
- ▶ Install a low loss header or buffer cylinder.

The lead room is the room where the remote control is installed, preferably the living room or bathroom. The lead room can be regulated with an external programming unit, or indirectly by adjusting the heating curve. See chapter „Operation / MAIN MENU / SETTINGS / HEATING“ in the operating instructions.

If an underfloor heating thermostat is installed, it should be set with a sufficient differential (at least 20 K) from the maximum set heating circuit temperature. The electrical connection of the underfloor heating thermostat is shown in chapter „Specification / Connection examples“.



Material losses

In the „INFO“ menu, the appliance offers the option to display the water pressure.
▶ Ensure that the pump does not run without water.

5.5 Water connection



Material losses

Never install the push-fit connectors in the DHW line. Never install the push-fit connectors to the solar flow or solar return connections. Only install the push-fit connectors in the heating circuit.

Stainless steel, zinc-plated steel, copper or plastic pipework are approved materials for the cold water line.

We approve stainless steel, copper or plastic pipework for the DHW line.

- ▶ Remove the protective caps from the cold water inlet and DHW outlet connections.

INSTALLATION

Installation

Safety valve

The appliance is a sealed unvented DHW cylinder. Provide the appliance with a pressure relief valve.

- ▶ Install a type-tested safety valve in the cold water supply line. The response pressure of the safety valve must be below or equal to the permissible operating pressure of the DHW cylinder.

The safety valve protects the appliance against unacceptable excess pressure. The diameter of the cold water supply line must be no greater than the diameter of the safety valve.

- ▶ Ensure that the expansion water escaping from the safety valve can drip into a drain, e.g. a tank or funnel.

Ensure the drain cannot be shut off.

- ▶ Size the drain so that water can drain off unimpeded when the safety valve is fully opened.
- ▶ Ensure that the discharge pipe of the safety valve is open to the atmosphere.
- ▶ Fit the discharge pipe of the safety valve with a constant downward slope and in a room free from the risk of frost.

Pressure reducing valve

Bear in mind that, depending on the static pressure, you may also need a pressure reducing valve.

DHW circulation

DHW circulation is not recommended for reasons of poor energy efficiency. If DHW circulation is required due to unfavourable pipework or for reasons of convenience, you must install the DHW circulation in accordance with applicable standards. To reduce pump runtime and energy demand, we recommend imposing time and temperature controls on activation of the circulation pump. A DHW circulation pipe kit and circulation pump can be found in our range of accessories.

5.6 Filling the DHW cylinder

The DHW cylinder can be filled via the cold water inlet connection.

- ▶ Open one or more hot water draw-off points to fill the DHW cylinder.
- ▶ Close the hot water draw-off points once the cylinder is full.

5.7 Option: Connecting the second DHW cylinder

- ▶ XD04-TX: Connect the temperature sensor for the second DHW cylinder. See chapter „Electrical connection / Connecting sensors“. The temperature sensor must be type Pt1000.

5.8 Condensate drain and overpressure valve

- ▶ Check the position of the internal condensate pump in the function module. The condensate pump must fully rest on the floor.

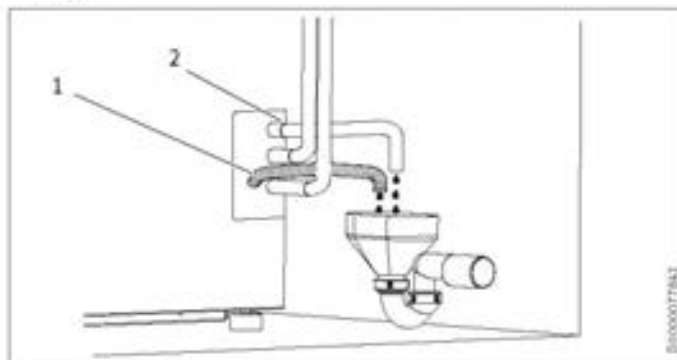

- 1 Safety valve drain
- 2 Condensate drain

On its r.h. side, the appliance is equipped with a condensate drain.

- ▶ Connect a condensate drain pipe to the condensate drain.



Material losses

To ensure the condensate drains off correctly, never kink the condensate line. If necessary, create a loop.

- ▶ Route the condensate line with a sufficient fall.

Route the condensate into a floor drain. When doing so, ensure the drain is adequately ventilated, e.g. free discharge into a siphon. Use a condensate pump if there is insufficient fall.

- ▶ If using a condensate pump, ensure that it delivers at least 6 l/min.

Pressure relief valve drain

On the r.h. side of the appliance, the safety valve drain connection also routes the pressure relief valve discharge hose out of the casing. Ensure that draining water can run off freely.

5.9 Electrical connection



WARNING Electrocutation

Only qualified electricians may carry out the connection in accordance with these instructions. Carry out all electrical connection and installation work in accordance with national and regional regulations.



WARNING Electrocutation

Disconnect the appliance from the power supply before carrying out work on the control panel.



WARNING Electrocutation

The connection to the power supply must be in the form of a permanent connection. The appliance must be able to be separated from the power supply by an isolator that disconnects all poles with at least 3 mm contact separation. This requirement can be met by using contactors, circuit breakers, fuses/MCBs, etc.

INSTALLATION

Installation



WARNING Electrocutation

Only components that operate with safety extra low voltage (SELV) and that ensure secure separation from the mains voltage supply may be connected to the low voltage terminals of the appliance. Connecting other components can make parts of the appliance and connected components live.
 ▶ Only use components which have been approved by us.



Material losses

The specified voltage must match the mains voltage. Observe the type plate.



Material losses

The cable entries at the back of the appliance are closed with cable grommets. To prevent an ingress of water, cut as small a hole as possible in the cable grommet.



Note

The leakage current of this appliance can be > 3.5 mA.

5.9.1 General information

The electrical data is given in the chapter „Specification/Data table“.



Note

If cooling is to be provided by means of an area heating system, always use an external programming unit (see chapter "Appliance description / Further accessories"). An external programming unit can capture the relative humidity in the air, helping to prevent humidity condensing on surfaces inside the room.

Cable routing

- ▶ Push all connecting cables and sensor leads through one of the „Entry electrical cables“ ducts in the back panel of the function module.

Safety temperature controller for underfloor heating system



Material losses

In order to prevent excessively high flow temperatures in the underfloor heating system in the event of a fault, we always recommend using a safety temperature controller to limit the system temperature.

Safety equipment for simultaneous operation of ventilation unit and combustion equipment

- ▶ XD03-13/14: Connect the safety equipment using a floating contact.

5.9.2 Control panel

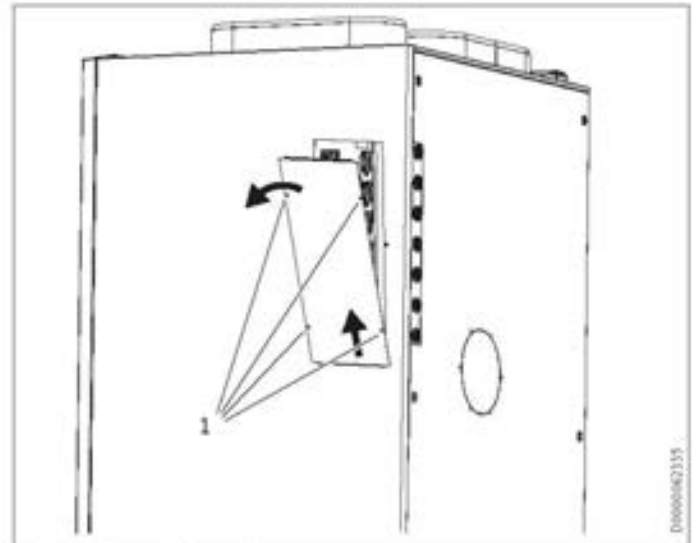

- 1 Control panel fastening screws

- ▶ Undo the fixing screws of the control panel cover.



Note

A serrated washer is used on one of the fastening screws to earth the control panel cover. When you refit the control panel cover after working at the control panel, place the serrated washer behind the fastening screw.

The control panel cover is held in place at the lower end by a tab that slots behind the appliance side panel.

- ▶ Push the control panel cover upwards and pull out at the bottom to remove it from the appliance.

5.9.3 Heat pump (compressor) and electric emergency/booster heater

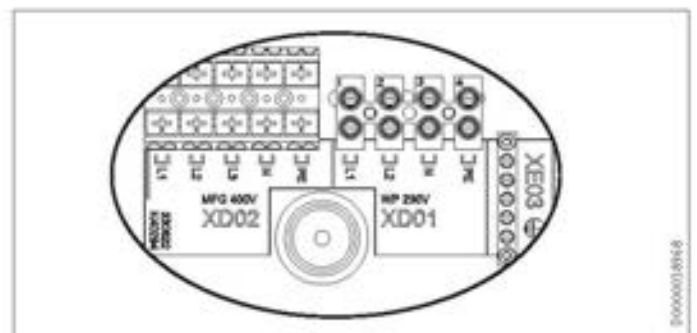

XD01	WP	Heat pump	L1 Compressor
			L2 Heat pump fan
XD02	MFG	Electric emergency/booster heater of the multifunction assembly	

For optimum function, connect all three stages of the electric emergency/booster heater.

INSTALLATION

Installation

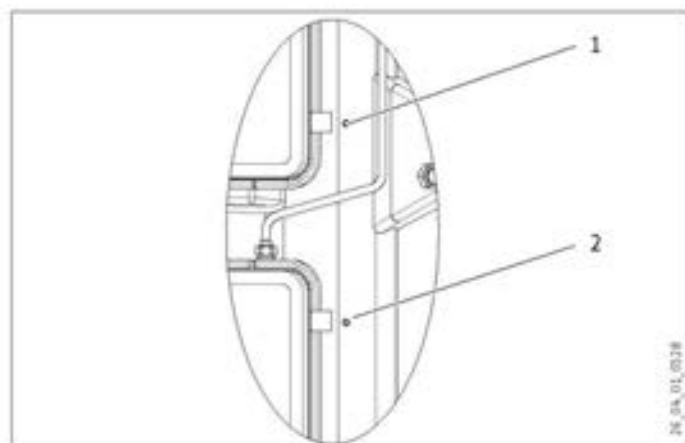

- 1 Sensor well for the cylinder temperature sensor (economy mode/buffer mode)
- 2 Sensor well for the cylinder temperature sensor (Comfort)

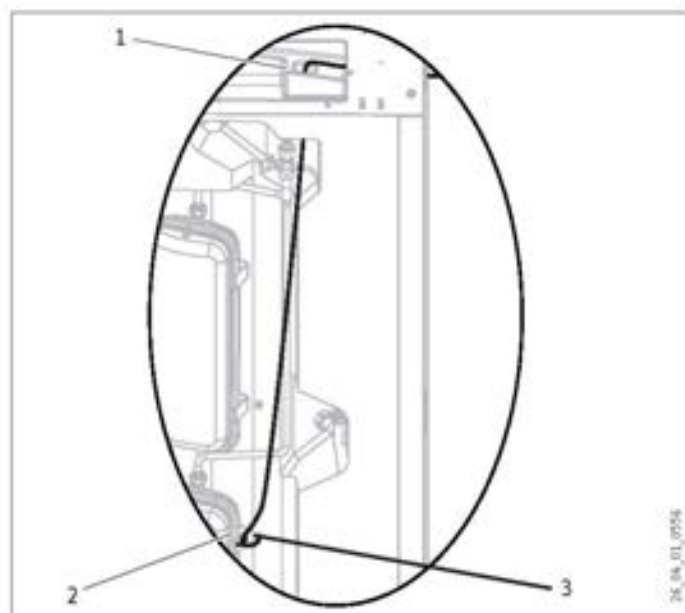

- 1 Aperture in the thermal insulation for the sensor lead
 - 2 Clamp (prevents the cylinder temperature sensor from slipping out)
 - 3 Cylinder temperature sensor inside the sensor well
- ▶ Insert the cylinder temperature sensor into the cylinder sensor well. Ensure that the cylinder temperature sensor is seated correctly.

The sensors integrated in the appliance, the sensors supplied and the outside sensor are PTC and Pt1000 sensors. The collector sensor supplied is a Pt1000 sensor.

5.9.8 Connecting sensors

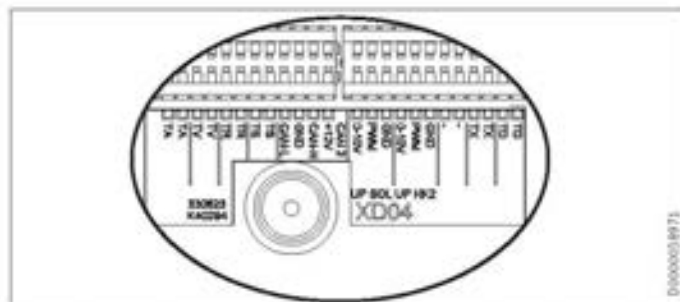

XD04 External terminals (Safety extra Low voltage)

TA	Outside temperature sensor
TV	Mixer circuit flow temperature sensor
TR	Room temperature sensor
TS	Solar temperature sensor
TX	Temperature sensor for second DHW cylinder
TD	No function

Outside temperature sensor AFS 2

The outside temperature sensor should have full and unprotected exposure to the weather. Never fit it above windows, doors, light wells or air ducts, and never subject it to direct insolation. Install the outside temperature sensor on a north or north-east facing wall on the exterior side of a heated room.

Never install the outside temperature sensor near an exhaust air discharge or any other influencing factors (e.g. drier discharge).

The minimum height above the ground is 2.5 m, and minimum side clearance to windows and doors is 1 m.

- ▶ Remove the cover of the sensor enclosure.
- ▶ Secure the sensor enclosure to the wall using the screw provided.
- ▶ Route the sensor lead through the cable entry in the back panel of the function module.
- ▶ XD04-TA: Connect the sensor lead.
- ▶ Connect the sensor lead to the outside sensor.
- ▶ Place the cover on the sensor enclosure so that it clicks audibly into place.

Room temperature and solar sensor

If planned as part of the system configuration, install the sensors according to the sensor installation instructions.

- ▶ Route the sensor lead through the cable entry in the back panel of the function module.
- ▶ XD04-TR: Connect the room temperature sensor.
- ▶ XD04-TS: Connect the solar sensor.

INSTALLATION

Installation

5.9.9 CAN BUS

Connecting the external programming unit



Note

Check whether the room in which the external programming unit is installed receives a lot of warmth, for example sunlight. If it is warmed from outside, the device might regulate the flow temperature downwards. As a result, the temperature in other rooms may be lower than desired.

With an external programming unit, you can switch all appliance functions and make all settings from the living space. In addition, the external programming unit captures the room temperature. If required, this value influences the heating curve. With this, you can reduce the heating curve if the set room temperature in the lead room, i.e. the room where the programming unit is installed, is exceeded (for example through insolation or a wood stove).

Room influence weighting can be set using the „ROOM INFLUENCE“ parameter.

■ SETTINGS

HEATING

HEATING CURVE HC1

ROOM INFLUENCE HC1

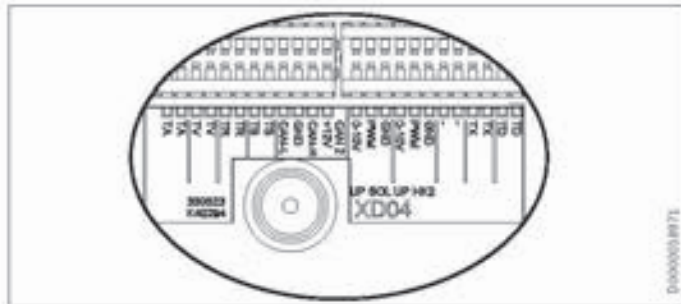

XDD4 CAN2 (CAN BUS, Safety extra low voltage)

CAN-L	Low
GND	Ground
CAN-H	High
+12V	

Route a standard data cable with at least four cores from the appliance to the mounting position of the remote control.

Example:

- J-Y(ST)Y 2x2x0.8 mm
- LiYCY 2x2x0.5 mm²

From approx. 50 m cable length greater cable cross-sections should be used.



Note

Observe correct separation when installing the BUS cable, the mains power cable and the sensor leads.

Internet Service Gateway

The Internet Service Gateway (ISG) enables you to operate the appliance within your local home network and via the internet when on the go.

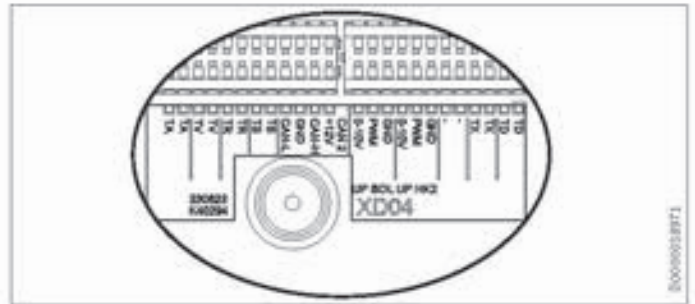

XDD4 CAN2 (CAN BUS, Safety extra low voltage)

CAN-L	Low
GND	Ground
CAN-H	High

The power supply to the ISG is not provided via the appliance.

► Also observe the ISG operating instructions.

The CAN BUS cable conductors are allocated as follows:

White	High
Brown	Low
Black	Earth (Ground)

5.10 Filling and venting the heating system

Depending on the heating system, check whether the expansion vessels in the appliance meet the requirements (see chapter „Specification“) and whether their pre-charge pressure is sufficient.

Checking the expansion vessels

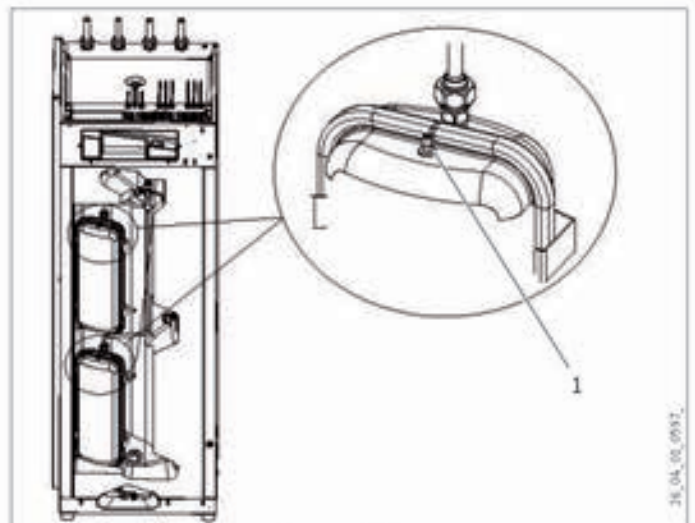

1 Fill valve of the expansion vessel

- Remove the protective caps from the fill valves on the expansion vessels.
- Check the pre-charge pressure of the expansion vessel using a pressure gauge. Please note that the system must be non-pressurised.

INSTALLATION

Installation

- ▶ Refit the protective caps on the fill valves.

Determine the fill pressure

Volume of the diaphragm expansion vessels integrated into the appliance	l	15
Expansion vessel pre-charge pressure (P0)	bar	0.75

If the height difference Δh between the highest point of the heating system and the diaphragm expansion vessel is no more than 6 m, the diaphragm expansion vessel can be used without any changes being required.

- ▶ Fill the heating system to a pressure of at least 1.1 bar (P0 + 0.3 bar). Observe the safety valve's response pressure of 3 bar.

If the height difference between the highest point of the heating system and the diaphragm expansion vessel is more than 6 m, the pre-charge pressure needs to be adapted.

- ▶ Calculate the pre-charge pressure:

$$P_0 = \frac{\Delta h}{10} + 0,2 \text{ bar}$$

- ▶ Note that the heating system fill pressure increases accordingly.
- ▶ Check whether a further external diaphragm expansion vessel needs to be installed.
- ▶ Fill the heating system to the appropriate pressure (P0 + 0.3 bar). Observe the safety valve's response pressure of 3 bar.

Filling the heating system



Material losses

High flow rates or water hammer can damage the appliance.

- ▶ Fill the appliance at a low flow rate.

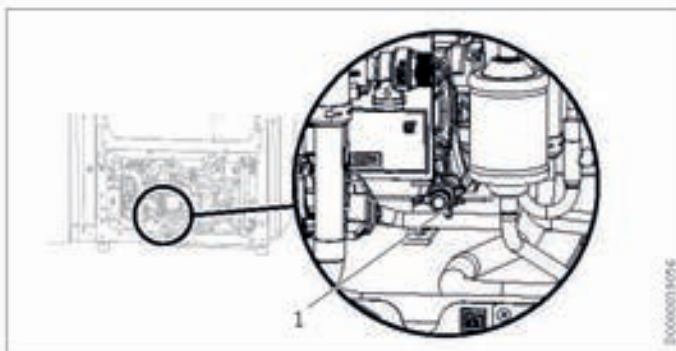

- 1 Drain connection for filling and draining the heating circuit
- ▶ Undo the cap from the drain connection.
 - ▶ Connect the fill hose with a quick-action hose coupling.
 - ▶ Open the drain connection by turning the star grip.

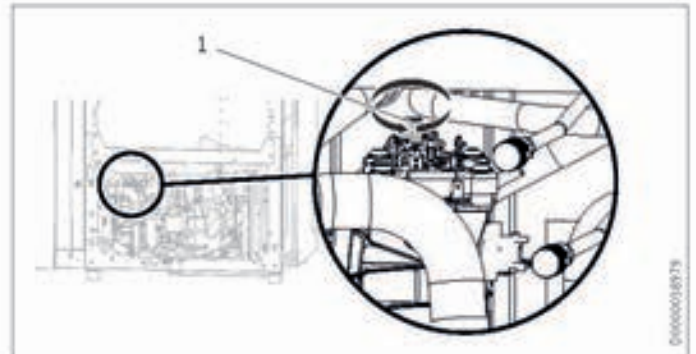

- 1 Air vent valve on the multifunction assembly
- ▶ Open the air vent valve of the multifunction assembly by turning anti-clockwise.

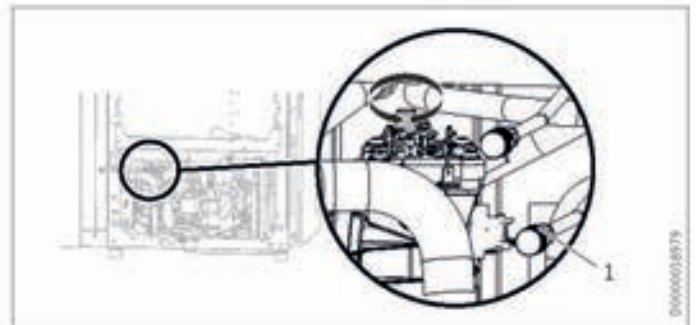

- 1 Air vent valve on the circulation pump
- ▶ Open the air vent valve on the circulation pump by pulling its head upwards.
 - ▶ After venting, check whether the air vent valve of the multifunction assembly or circulation pump drips.

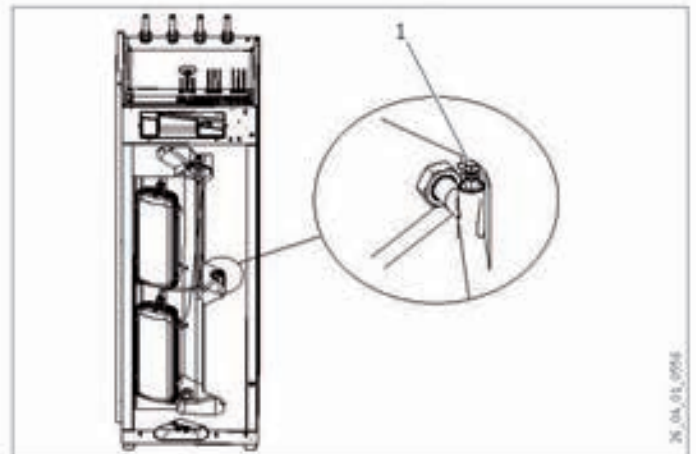

- 1 Air vent valve of the DHW heating line
- ▶ Open the air vent valve of the DHW heating line.
 - ▶ For filling, turn the lever on the drain connection 90° anti-clockwise.
 - ▶ Switch on the appliance and set the displayed system pressure at the programming unit („PRESSURE HTG CIRC“ parameter).
 - ▶ Fill the system.
 - ▶ After filling close the drain connection.
 - ▶ Fit the cap on the drain connection.

You can check the water pressure in the heating circuit on the programming unit with the „PRESSURE HTG CIRC“ value.

INSTALLATION

Installation

- ▶ Determine the „PRESSURE HTG CIRC“ value for one of the three favourites. For this, navigate from the default display to the „FAVOURITES“ parameter.



Note

Proceed carefully when filling as the "PRESSURE HTG CIRC" value is only updated every 10 seconds. If you have determined the value not in association with one of your favourites but instead by calling up the "INFO" parameter, the value will only be updated every 60 sections.



Note

Air locks in the system are detrimental to the appliance operation.

- ▶ Vent the pipework carefully.

Venting the plate heat exchanger

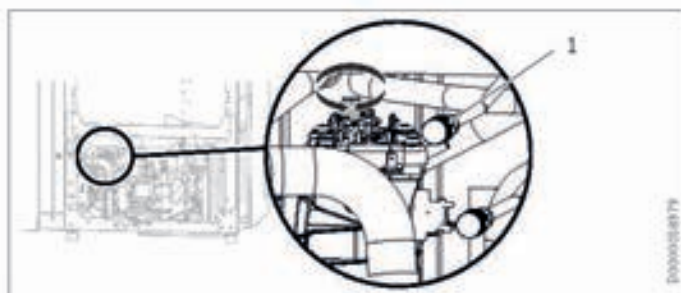

- 1 Air vent valve of the plate heat exchanger

5.11 Fitting the appliance casing

5.11.1 Installing front panel and cover of the cylinder module

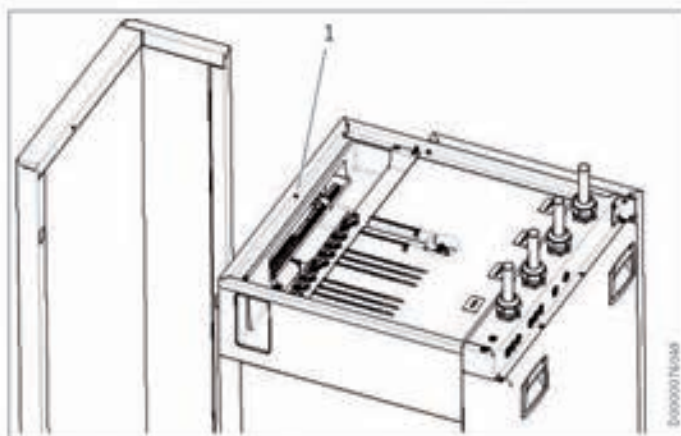

- 1 Screw for securing the front panel
- ▶ Hook the front panel of the cylinder module into the hooks on the cylinder module frame.
 - ▶ Turn the screw to secure the front panel into the hole provided.
 - ▶ Place the cover onto the cylinder module so that the labels with the terminal designations are located behind the terminals.
 - ▶ Secure the cylinder module cover with screws.

5.11.2 Installing front panel of the function module

- ▶ Attach the lower front panel of the function module using screws.
- ▶ Close the function module door and lock it.

5.11.3 Mounting the programming unit

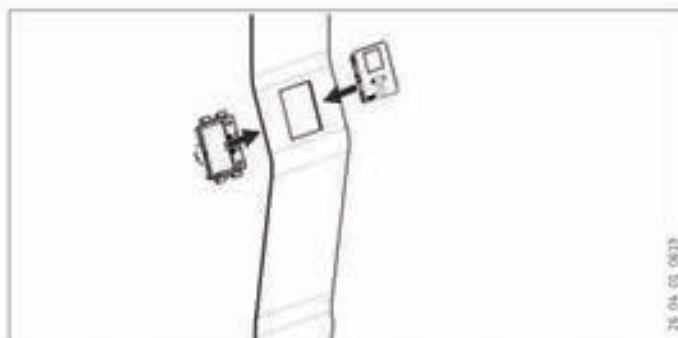

- ▶ Position the programming unit from the front in the opening of the fascia.
- ▶ Then fit the frame at the back of the fascia together with the programming unit, until the programming unit clicks into place in the frame.

5.11.4 Fitting the fascia

- ▶ Hook the rear fascia frame into the hooks provided on the appliance front.

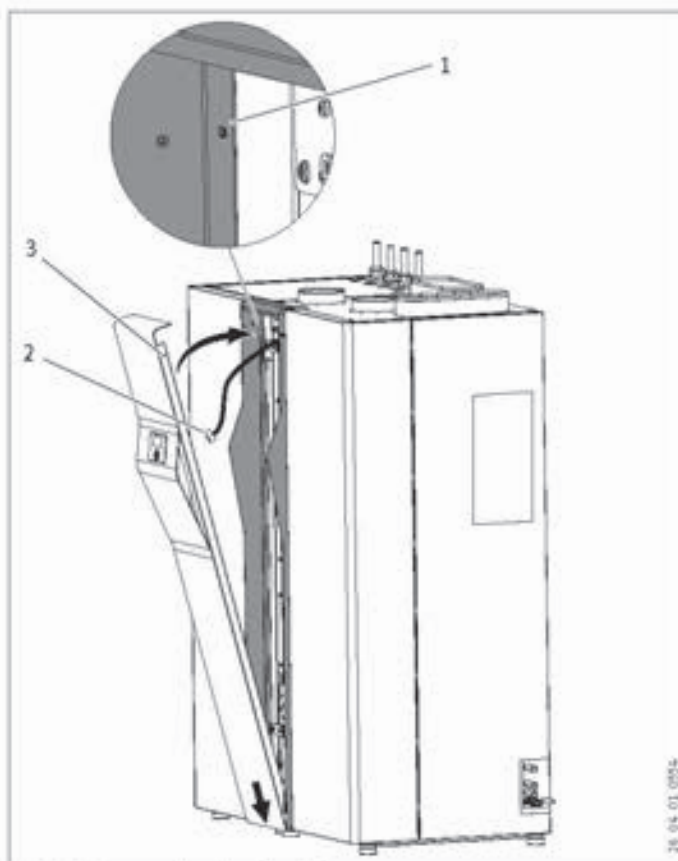

- 1 Slot for securing the fascia frame
 - 2 BUS cable
 - 3 Screw for securing the fascia on the fascia frame
- ▶ Secure the fascia frame with one screw in the slot on the appliance.

INSTALLATION

Installation

- ▶ Connect the bus cable to the programming unit. The BUS cable must run upwards with the jumper in the l.h. side.
- ▶ Insert the fascia from the top into the fascia frame.

The fascia has one screw each on the l.h. and r.h. side.

- ▶ Tighten these screws to secure the fascia to the fascia frame.

5.12 Outdoor air and exhaust air hose installation



Note

If connecting a geothermal heat exchanger, convert the appliance as described in chapter "Outdoor air mechanical ventilation connection option" before fitting the air hoses.

Air hoses guide the intake air (outdoor air) from the outside to the heat pump, and route the discharge air (exhaust air) to the outdoors (see chapter "Required accessories"). These are highly flexible, thermally insulated and self-extinguishing in case of fire in accordance with ASTM D 1692-67 T.

5.12.1 Information on routing the air hoses

- ▶ Use a sharp knife to trim the hose to the required length. Cut the Bowden core using wire cutters.

If you need to extend the air hose, push the core of two hoses together. There should be approx. 30 cm overlap.

The total length of hoses on the air intake and discharge sides must not exceed 8 m.

Never incorporate more than four 90° bends. The radius of the bends must be at least 365 mm, relative to the centre of the hose.



Note

When installing an outdoor air connection maintain $\Delta p < 20$ Pa. In other words, the outdoor air duct run should be as short as possible.

The air hose tends to sag because of its flexibility. Secure it at intervals of approx. 1 m.

5.12.2 Fitting the air hoses

- ▶ Adapt the shape of the air hose to match the oval connection panel of the function module.

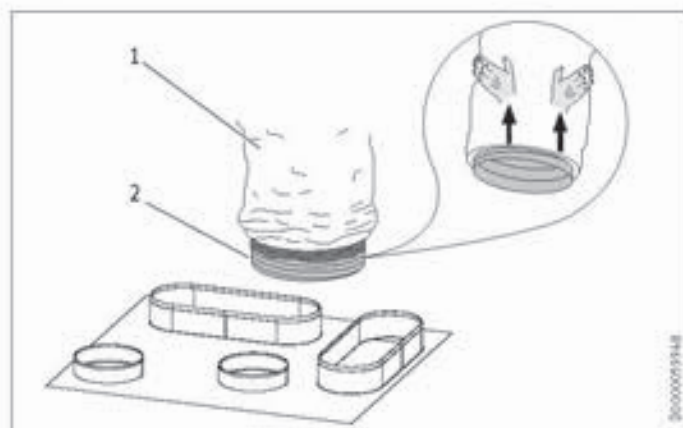

- 1 External hose
- 2 Internal hose

- ▶ Push the external hose and the thermal insulation slightly up so that the internal hose of the air hose protrudes slightly.

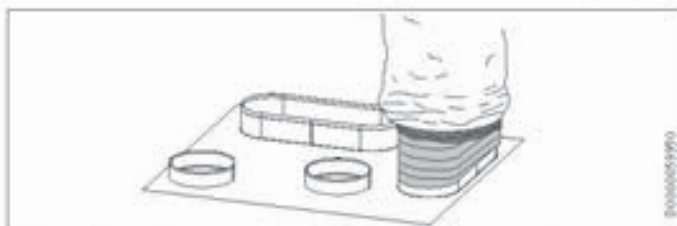

- ▶ Invert the internal hose halfway down the connector.

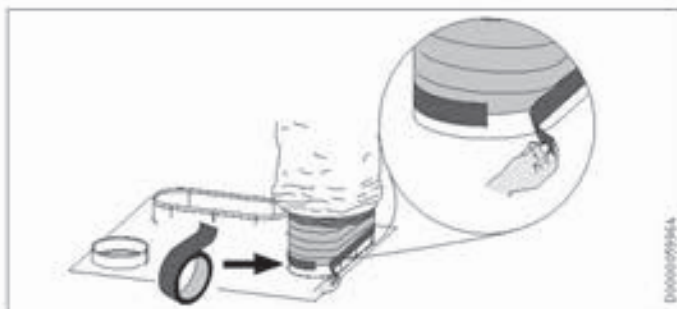

- ▶ Seal the transition from the internal hose to the connector with the self-adhesive thermal insulation tape supplied.

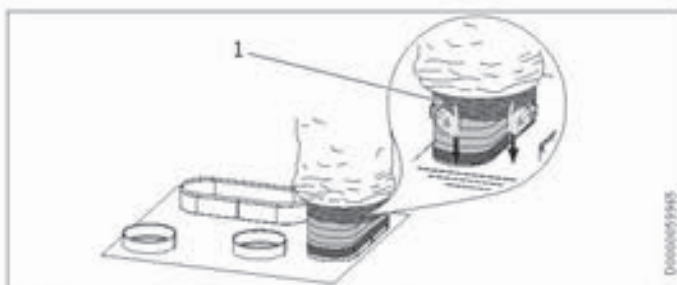

1 Film

- ▶ Pull the sleeves of the sound-optimised hoses (LSWP 315-4 S) over the connections.

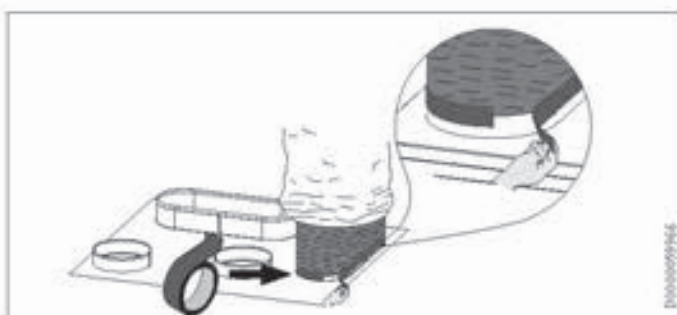

- ▶ For the sound optimised hoses (LSWP 315-4 S), use the self adhesive thermal insulation provided to seal the transition from the hose sleeve to the connection.

INSTALLATION

Commissioning

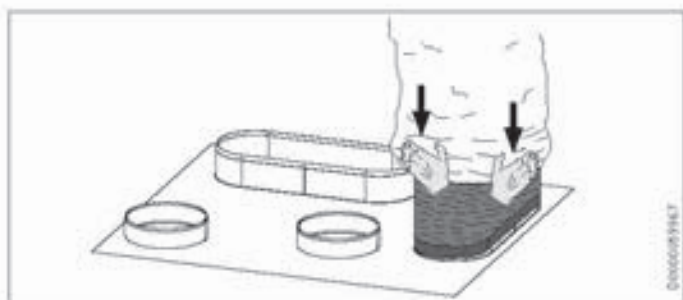

- ▶ Pull the external hose and the thermal insulation below it over the connector.
- ▶ Tuck the thermal insulation into the outer hose in such a way that the thermal insulation is no longer visible.

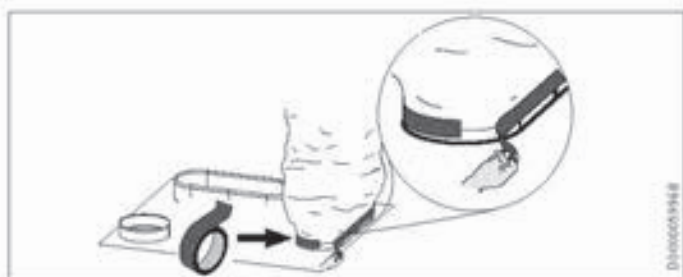

- ▶ Seal the transition from the external hose to the connector with the self-adhesive thermal insulation tape supplied.

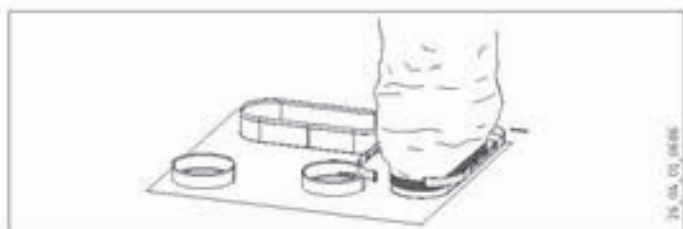

- ▶ Secure the external hose with the hose clip to the connector.

- ! **Material losses**
Always cover the air intake and discharge with wire grilles, and secure the hoses against slippage.

Hose connection panels or wall outlets with hose connection and grilles are available for hose connections to exterior wall knock-outs or cellar windows.

5.13 Installing extract air and supply air pipes

Install with the material you can obtain from us or with commercially available folded spiral-seam tubes.

- ! **Material losses**
During installation, ensure that no metal swarf enters the pipework. However, should this occur, remove this debris, otherwise the fans may be damaged.

Where the extract air and supply air pipes are routed through unheated rooms, they must be thermally insulated. If, when connecting a geothermal heat exchanger, the outdoor air pipe is routed through heated rooms, this pipe must also be thermally insulated with vapour diffusion-proof material.

5.13.1 Silencer

Fit silencers as near as possible to the appliance into the extract air and the supply air flows. Fit a silencer just upstream of bedrooms.

If a room with a high noise level needs to be ventilated, install additional silencers in the supply air pipe or extract air pipe of this room to reduce sound transmission to adjacent rooms.

5.13.2 Cleaning apertures

- ▶ Provide cleaning apertures when installing the air ducts, so the air ducts can be checked at regular intervals and cleaned if necessary.

5.13.3 Supply and extract air vents

Supply and extract air vents for the living space are available for wall or ceiling mounting.

When venting the kitchen, ensure that the extract air vent is fitted as far as possible from the cooker.

- ! **Material losses**
Never link cooker hoods to the ventilation system.

5.13.4 Overflow apertures

Provide suitable overflow apertures since the air is only blown into living rooms and bedrooms, and is only extracted from unpleasant-smelling and humid rooms. For example, fit ventilation grilles in internal doors or walls, or increase the air gap below the door (≥ 8 mm) to ensure an unimpeded overflow and thereby air balancing.

6. Commissioning

- ! **WARNING Injury**
Only qualified contractors may commission this appliance and instruct the user.

- ! **Material losses**
Never operate the ventilation system if there are high levels of dust inside the building or outside in the immediate vicinity, as this could block the filter. Dust is created by cutting tiles or working with plasterboard, for example.

- ▶ Commission the system in accordance with this manual. Our customer service can provide commissioning support, which is chargeable.

- ! **Note**
If adjustments to the appliance control unit have to be made during commissioning, observe chapter "Operation" of the operating instructions and chapter "Settings" of these installation instructions.

6.1 Checks before commissioning

6.1.1 Heating system

- Are all connections on the central heating and DHW side connected and tightened?
- Was the heating system filled to the correct pressure and vented, and was the quick-acting air vent valve opened?

INSTALLATION

Commissioning

- Has the condensate hose been routed correctly?
- Was a vessel placed beneath the safety valve discharge hose?

6.1.2 Ventilation system

- Have the air ducts been installed correctly and sealed if required?
- Have all air connections been designed correctly?

6.1.3 Heat pump

- Have the insulated air hoses been installed in accordance with regulations? In particular, the outdoor air and exhaust air connections must be sealed carefully on both sides.
- Are the exterior wall outlets free from leaves and other contamination?



Note

Never fit any additional fly screens in the wall outlets.

6.1.4 Cylinder

- Has the cylinder been filled (hot tap open until water flows out)?
- Has a pressure reducing valve been installed if the water pressure is above 80 % of the permissible pressure?

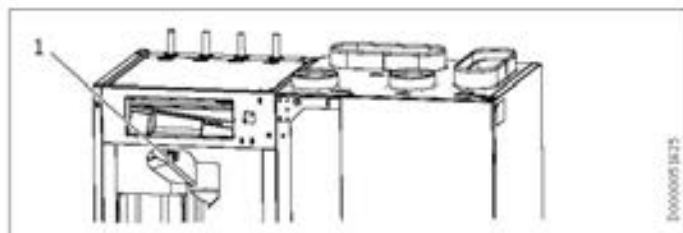

1 Plastic union nut



Material losses

The torque of the plastic union nut depends on the gasket used.

15 Nm = prefitted soft rubber gasket.

25 Nm = alternative hard gasket.

Keep to the permissible torque.

- Is the plastic union nut tight against leaks? If it is leaking, tighten the plastic union nut.

6.1.5 Temperature sensor

- Have outside sensors, cylinder temperature sensor and, if required, mixer circuit sensor and flow sensor for the second heating circuit been correctly positioned and connected?

6.1.6 Power supply

- Has the power supply been designed correctly and the earth conductor for the cylinder connected?
- Have all internal cables been connected correctly?

6.1.7 High limit safety cut-out

With ambient temperatures of below $-10\text{ }^{\circ}\text{C}$, it is possible that the high limit safety cut-out of the electric emergency/booster heater may trip.

- ▶ Check whether the high limit safety cut-out has tripped.

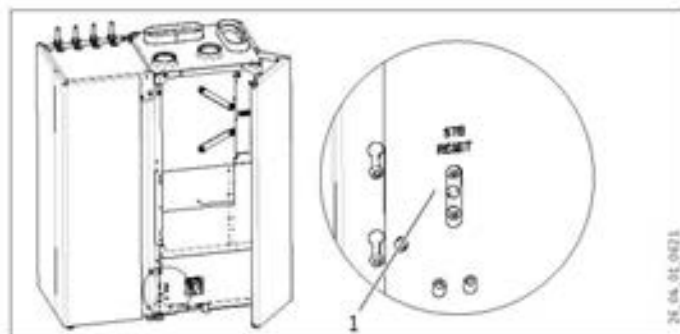

1 Reset button for high limit safety cut-out

- ▶ Reset the high limit safety cut-out by pressing the reset button.

6.1.8 Condensate pump

- ▶ Check the condensate pump before commissioning the appliance.
- ▶ Check whether the drain hose of the defrost tray is routed correctly.

6.2 Filter insertion



Material losses

Never operate the appliance without filters.

- ▶ Insert the supply air filter, included in the standard delivery, into the appliance.

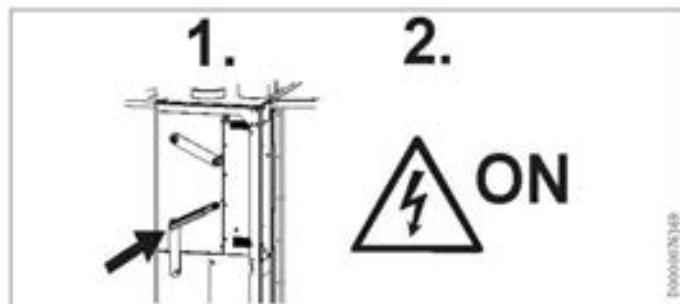

6.3 Commissioning via the programming unit

337705 Commissioning / Notification list

6.4 Recommissioning

- ▶ Carry out the work specified in chapter „Maintenance“.
- ▶ If there has been frost since the appliance was shut down, check all hydraulic lines for possible frost damage.
- ▶ Fill the DHW cylinder.
- ▶ Fill the heating circuit.
- ▶ Switch on the power supply.

7. Appliance shutdown



WARNING Injury

There will be no ventilation if the appliance is taken out of use. This may result to the development of mould fungus and damage to the building.

- ▶ Prevent the appliance being out of use for prolonged periods.



Note

Prevent the appliance being shut down if it is to be restarted later. Use the standby mode.

When shutting down, always carry out the following steps:

- ▶ Isolate the appliance fully from the power supply.



WARNING Burns

Hot water may escape when draining the DHW cylinder.

- ▶ Close the shut-off valve in the cold water supply line.
- ▶ Open the hot water taps on all draw-off points.

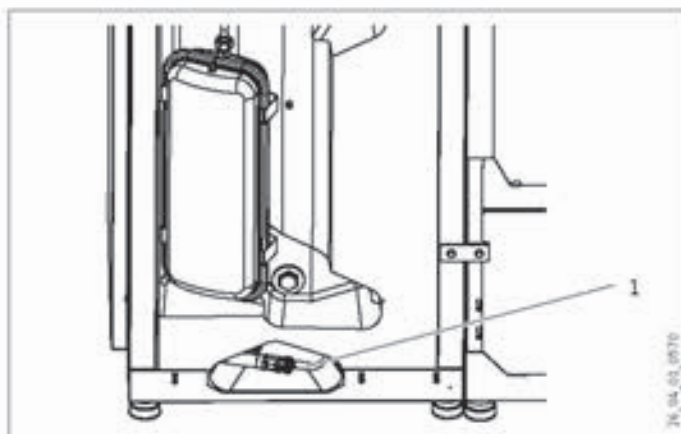

1 Drain connection of the DHW cylinder

- ▶ Fully drain the DHW cylinder.
- ▶ Drain the heating circuit.

In the case where the appliance is to be returned into use again later, first carry out the following:

- ▶ Remove the air filters.
- ▶ Carry out all service-related cleaning tasks, such as cleaning the condensate pan and the cross-countercurrent heat exchanger.



Material losses

- ▶ Mark the appliance to enable the recognition that the appliance has been fully shut down and that it must be refilled, checked and commissioned before restarting.
- ▶ Mark the appliance with the date when it was shut down.

8. Troubleshooting

8.1 Exhaust air fan is catching

If the exhaust air fan drags, return it into its correct position.

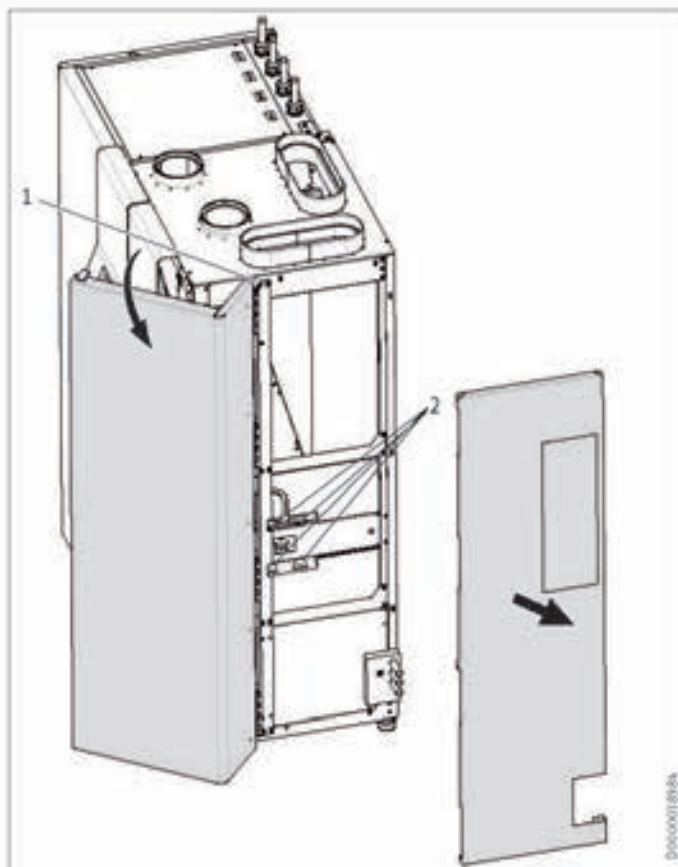

- 1 Fixing screw on the r.h. side panel
- 2 Fan strut fixing screws

- ▶ Open the function module door.

You will locate the fixing screw for the r.h. side panel in the gap between door and appliance.

- ▶ Undo the fixing screw from the r.h. side panel.
- ▶ Remove the r.h. side panel of the function module.
- ▶ Undo the fixing screws from the fan strut and push the strut so the exhaust air fan no longer drags. If necessary, increase the clearance between the fan nozzle and the fan using spacers.
- ▶ Refit the fixing screws to the fan strut.
- ▶ Insert the fixing screw into the r.h. side panel.

8.2 Cleaning defrost pan



Material losses

Do not use any cleaning agents, just water.

Clean the defrost tray if it is dirty. It may be contaminated with leaves, mineral wool residues (from insulation) or polystyrene balls (from drainage tiles).

- ▶ Remove the central front panel as described in chapter „Cleaning the evaporator fins“.

8.3 Circulation pump

If the LED on the heating circuit pump flashes red even though there is an active heat demand, disconnect the power supply for 30 seconds. If the circulation pump does not run after switching the power supply back on, replace the circulation pump.

8.4 Fault messages in the programming unit



Note

The message list can be found in a separate supplement.

If there is a fault in the system, a fault message appears on the display. There is a fault memory so you can check earlier faults. This is found under „MENU / CONTRACTOR / FAULT SEARCH“. The programming unit shows the ten most recent faults.

Some fault messages prompt you to press the reset button.

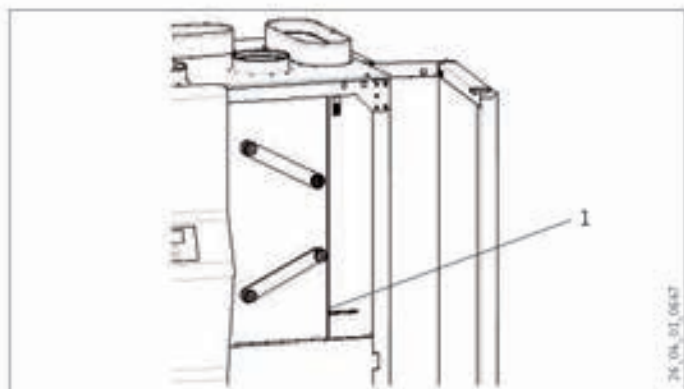

1 Electronics reset button

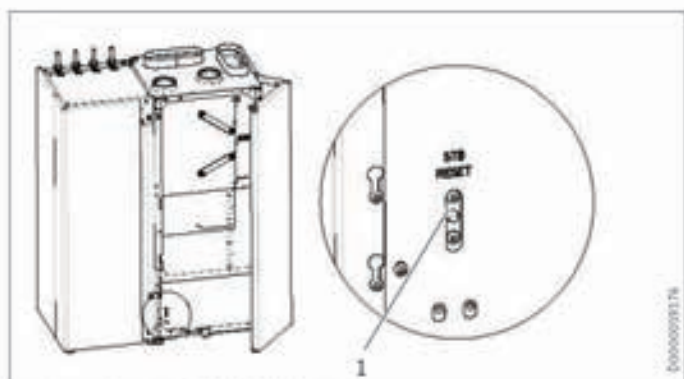

1 Reset button for high limit safety cut-out

9. Maintenance and cleaning



WARNING Electrocutation

▶ Prior to commencing any service or cleaning work, isolate the appliance across all poles from the power supply.

9.1 Cleaning the air/air heat exchanger

Check and clean the cross-counter-current heat exchanger at least once a year.

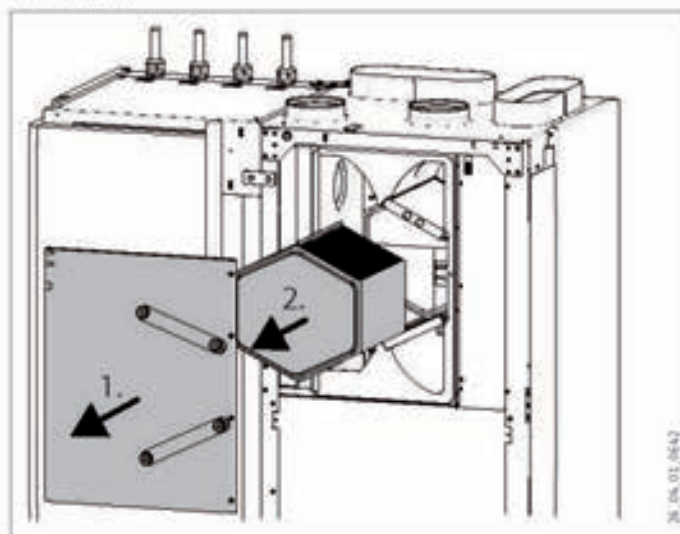

1 Upper front panel

2 Cross-counter-current heat exchanger

- ▶ Open the door of the function module (r.h. half of the appliance).
- ▶ Remove the fascia fitted to the centre of the appliance.
- ▶ Remove the upper front panel.
- ▶ If the contamination level is modest, clean the cross-counter-current heat exchanger with the brush attachment of a vacuum cleaner.
- ▶ If more severe contamination is visible and extends into the cross-counter-current heat exchanger, clean it as described in the following.
- ▶ Pull out the cross-counter-current heat exchanger.
- ▶ Clean the cross-counter-current heat exchanger with warm water. Do not use solvents.
- ▶ Afterwards flush the cross-counter-current heat exchanger with warm water.
- ▶ Let the cross-counter-current heat exchanger dry out.

9.2 Cleaning the outdoor air filter

The outdoor air filter is fitted downstream of the cross-counter-current heat exchanger.

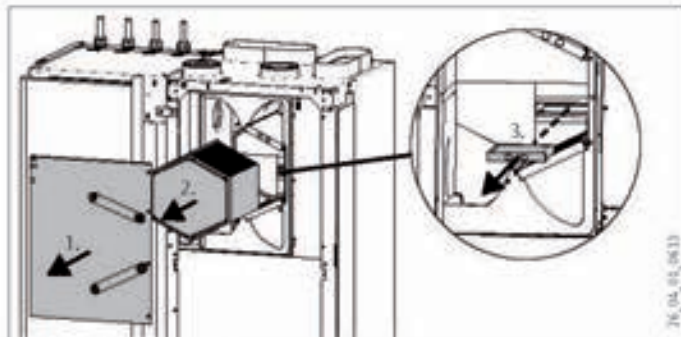

- 1 Upper front panel
- 2 Cross-counter-current heat exchanger
- 3 Outdoor air filter cassette

- ▶ Pull out the cross-counter-current heat exchanger.
- ▶ Grasp the outdoor air filter cassette by the grip holes and remove it.
- ▶ Remove the filter from the outdoor air filter cassette, clean it, and insert a new filter if required.
- ▶ Refit the outdoor air filter cassette in the appliance.
- ▶ Refit the cross-counter-current heat exchanger in the appliance.
- ▶ Refit the upper front panel and the fascia.

9.3 Cleaning the evaporator fins

Check the evaporator fins for dirt from time to time.

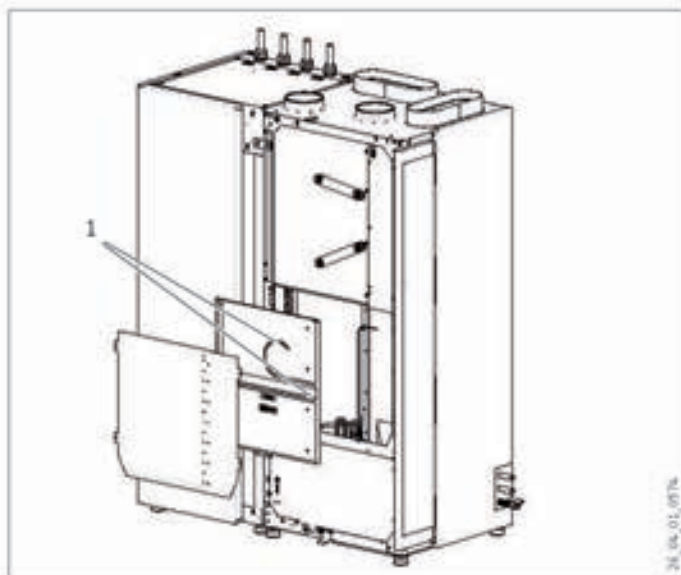

- 1 Defrost hose (hose of the pressure differential switch for capturing the end of defrosting)
- ▶ Undo the screws and remove the central front panel.
 - ▶ Remove the defrost hoses from the guide grooves in the EPS cover.
 - ▶ Pull the now accessible EPS cover 6 to 8 cm to the right.
 - ▶ Tilt the top of the EPS cover towards you from the appliance.
 - ▶ Pull the EPS cover upwards to remove.

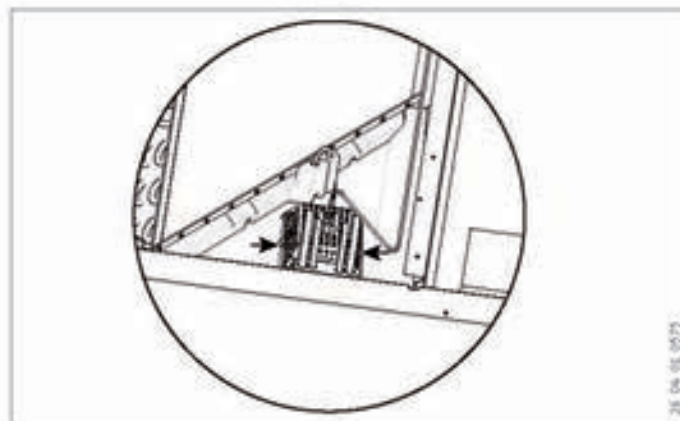

- ▶ Remove the dirt grille fitted above the condensate pan by compressing it from its sides and removing it upwards.
- ▶ Check the defrost pan drain and clean it, if required.



Below the evaporator is a two-part evaporator gasket. The two parts of the gasket are connected with a bracket.

- ▶ Pull the bracket upwards to remove.
- ▶ First remove the l.h. half of the evaporator cover.

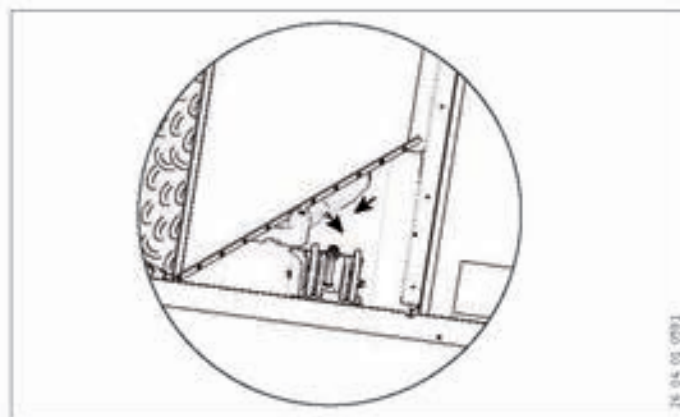

- ▶ Then remove the r.h. half of the evaporator cover.

! **Material losses**
Do not use any cleaning agents, just water.

! **Material losses**
Do not use a high pressure cleaner otherwise the evaporator fins may be bent.

- ▶ Spray water across the evaporator fins.
- ▶ Remove the water from the appliance using a wet suction device.
- ▶ Remove contaminants and blockages.



Note

Check the condensate drain regularly, at least once a year.

9.4 Cleaning the condensate drain

Check the condensate drain regularly.

- ▶ Remove the evaporator cover (see chapter „Cleaning the evaporator fins“).
- ▶ Remove dirt and blockages immediately.
- ▶ To test the drain, pour one litre of water, for example from two half-litre bottles, into the condensate pan.

If the condensate pan does not overflow, the drainage facility is adequate.

9.5 Cleaning the filter ball valve

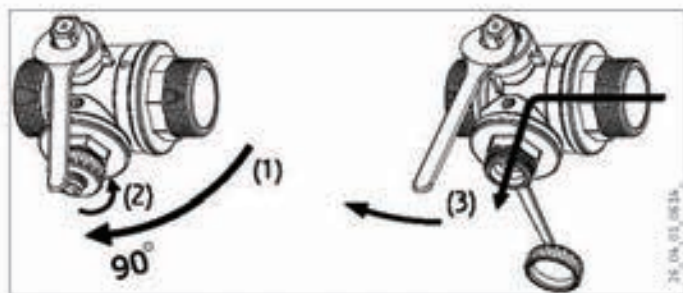

- ▶ Close the filter ball valve by turning it 90° clockwise.
- ▶ Undo the cap.
- ▶ If the filter element is contaminated, connect a short hose for backwashing.
- ▶ Place the free end of the hose in a bucket.
- ▶ Turn the filter ball valve 15° clockwise.
- ▶ Turn the filter ball valve 15° back again.
- ▶ Check whether cleaning was successful. Repeat backwashing if required.
- ▶ Refit the cap.
- ▶ Open the filter ball valve by turning it 90° anti-clockwise.
- ▶ Check the system fill pressure and adjust if required.

9.6 Replacing the anode

- ▶ Isolate the appliance from the power supply.
- ▶ Close the shut-off valve in the cold water supply.
- ▶ Remove the cover from the cylinder module.
- ▶ Remove the l.h. front panel of the cylinder module.
- ▶ Briefly open the lowest DHW draw-off point.

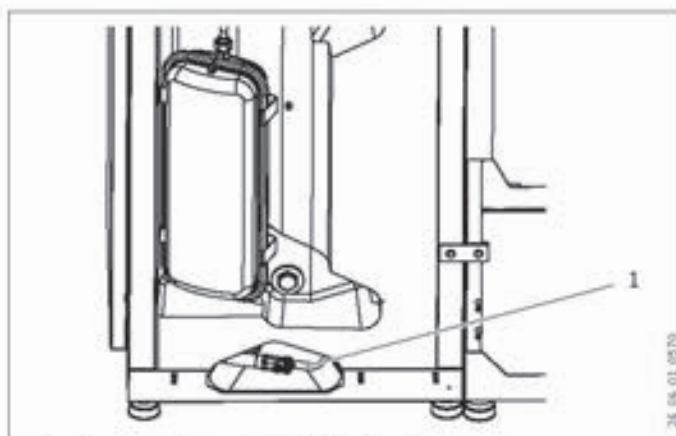

1 Drain connection of the DHW cylinder

- ▶ At the DHW cylinder drain valve, draw off approx. 20 litres of water.

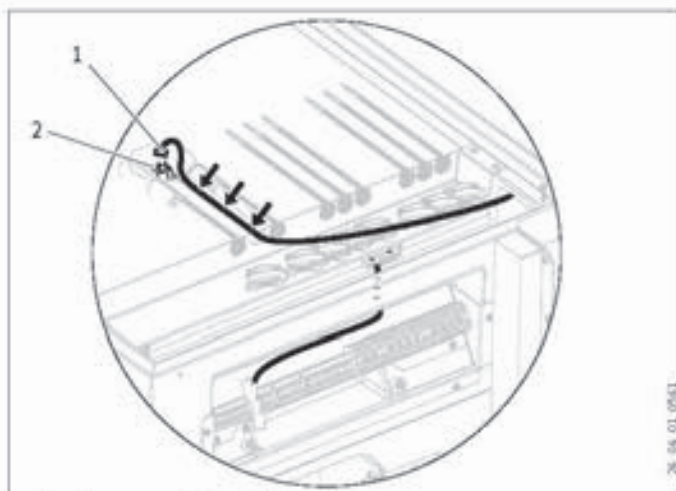

1 Anode connection at the cylinder

2 Anode

- ▶ Pull the anode cable plug from the anode.
- ▶ Remove the anode by turning it.
- ▶ Insert a new anode. Alternatively, you can also use a segmented anode.
- ▶ Push the plug of the anode cable back onto the anode.
- ▶ Open the shut-off valve in the cold water line.
- ▶ Vent the DHW pipework at the respective DHW draw-off points.

9.7 Checking the diaphragm expansion vessels

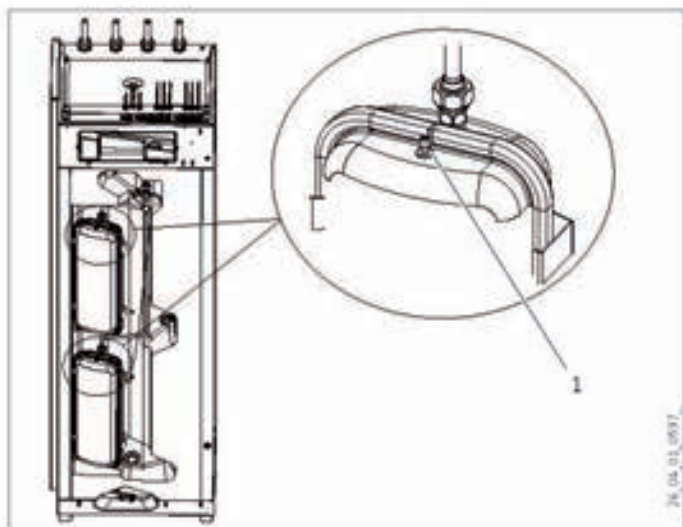

1 Fill valve of the expansion vessel

- ▶ Remove the protective caps from the fill valves on the expansion vessels.

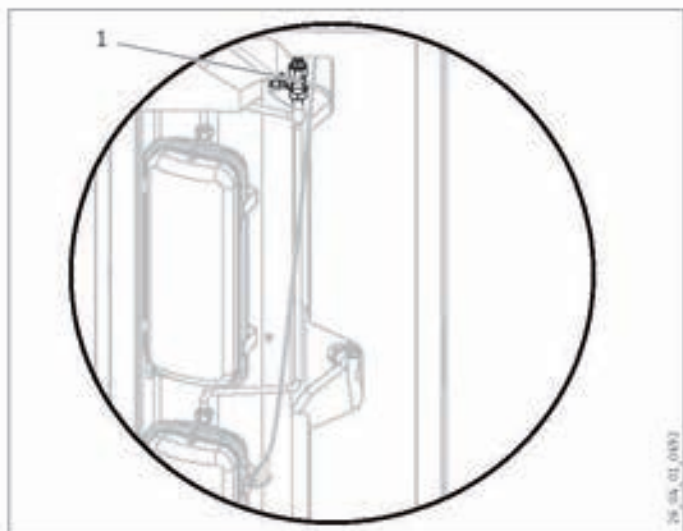

1 Cap valve

- ▶ Close the cap valve and depressurise the expansion vessel by draining the cap valve.
- ▶ Check the pre-charge pressure of the expansion vessel using a pressure gauge.
- ▶ Reopen the cap valve.
- ▶ Refit the protective caps on the fill valves.
- ▶ Reassemble the appliance in reverse order, i.e. fit the l.h. front panel and cover.
- ▶ After the appliance has been fully closed again, restore the power supply.

10. Specification

10.1 Dimensions and connections

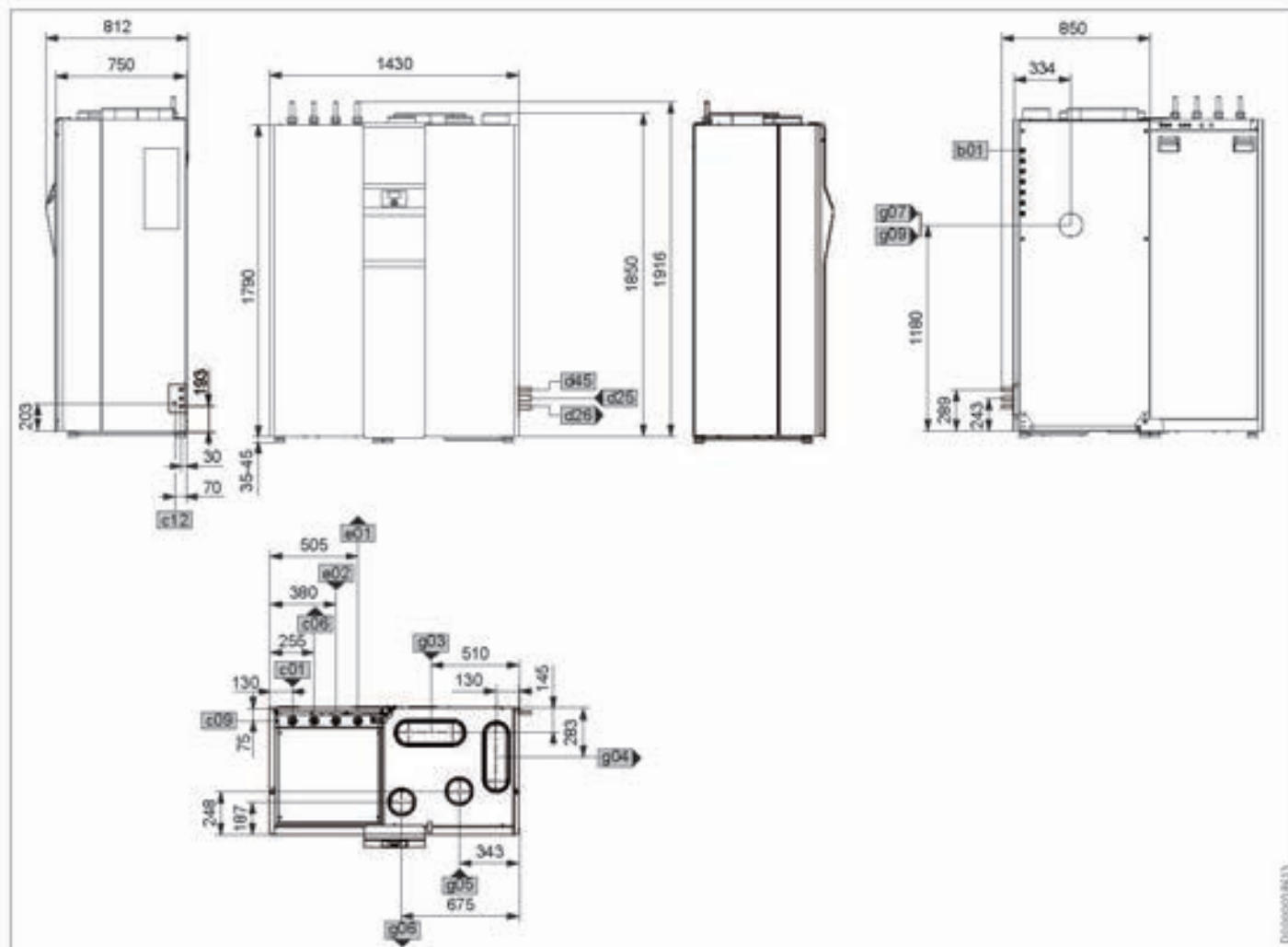

			LWZ 5 CS Premium	LWZ 8 CS Premium
b01	Entry electrical cables			
c01	Cold water inlet	Diameter	mm	22
c06	DHW outlet	Diameter	mm	22
c09	Entry DHW circulation			
c12	Safety valve drain	Diameter	mm	19
d25	Solar flow	Diameter	mm	22
d26	Solar return	Diameter	mm	22
d45	Condensate drain	Diameter	mm	22
e01	Heating flow	Diameter	mm	22
e02	Heating return	Diameter	mm	22
g03	Outdoor air	Nominal diameter	DN 315	DN 315
g04	Exhaust air	Nominal diameter	DN 315	DN 315
g05	Extract air	Nominal diameter	DN 160	DN 160
g06	Supply air	Nominal diameter	DN 160	DN 160
g07	Outdoor air geothermal heat exchanger	Nominal diameter	DN 160	DN 160
g09	Outdoor air mechanical ventilation opt.	Nominal diameter	DN 160	DN 160

10.2 Connection examples

Example 1: Without power-OFF periods

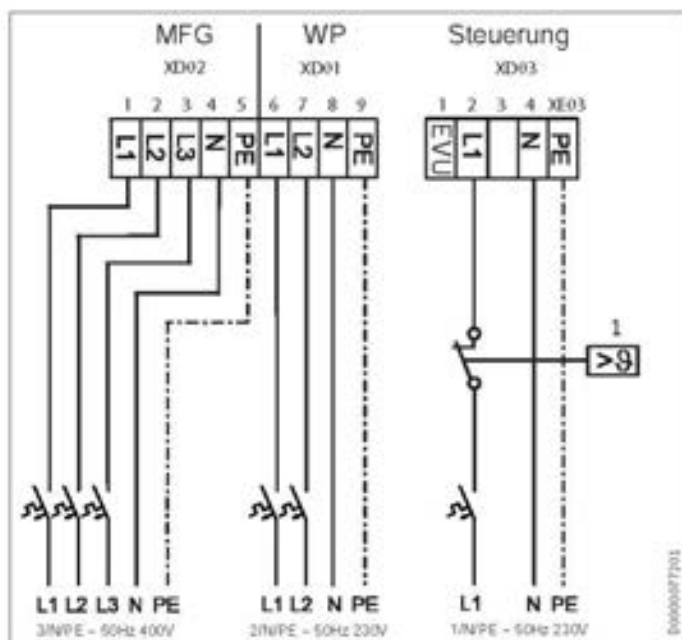

WP	Heat pump / Fan
MFG	Electric emergency/booster heater
Steuerung	Control
1	Underfloor heating thermostat (option) or safety equipment terminal for stove / fireplace

Example 2: Blocking time for electric emergency/booster heater

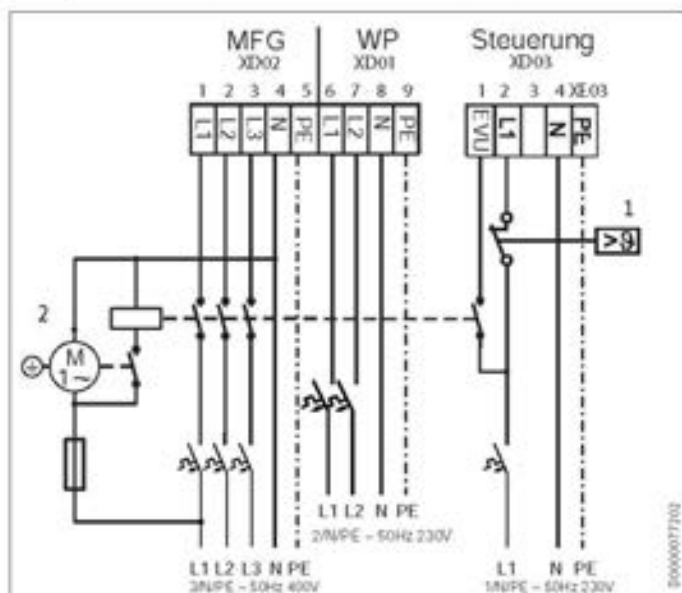

WP	Heat pump / Fan
MFG	Electric emergency/booster heater
Steuerung	Control
1	Underfloor heating thermostat (option) or safety equipment terminal for stove / fireplace
2	Time switch for power-OFF periods

10.3 Application range

Heating

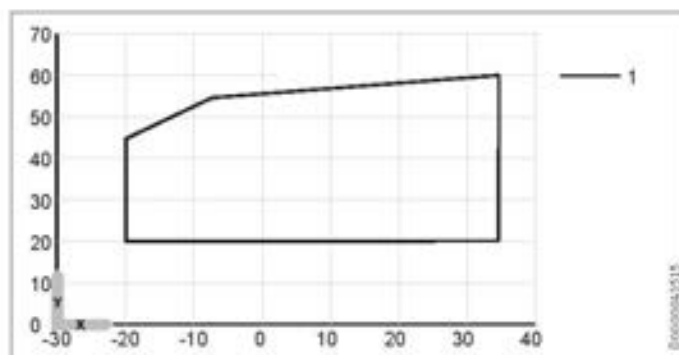

Cooling

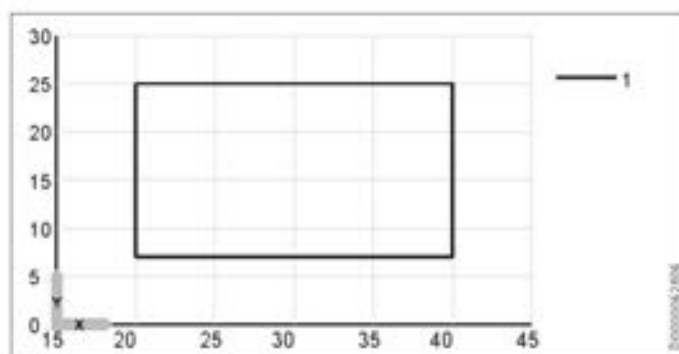

- 1 Application range limits
- X Outside temperature [°C]
- Y Flow temperature [°C]

10.4 Sensor resistance values

Temperature in °C	Pt1000 sensor Resistance in Ω	PTC sensor Resistance in Ω
-30	882	---
-20	922	1367
-10	961	1495
0	1000	1630
10	1039	1772
20	1078	1922
25	1097	2000
30	1117	2080
40	1155	2245
50	1194	2417
60	1232	2597
70	1271	2785
80	1309	2980
90	1347	3182
100	1385	3392
110	1423	---
120	1461	---

Note
When measuring with a multimeter, the resistance values serve only to identify faulty or incorrect sensors. Measuring with a multimeter is too imprecise to test for accuracy.

10.5 Wiring diagram

Wiring diagram key

AA02	Integral control unit	RF06	Ferrite core ring
AA04	Inverter	SF01	Reset button
AA06	Programming unit	XD01	Compressor/HP fan power supply
BF01	Heating circuit flow rate sensor	XD02	Instantaneous water heater (MFG) power supply
BL01	Condensate float switch	XD03	230 V PCB inputs power supply
BM03	Extract air humidity sensor	XD04	Terminals for external temperature sensor and CAN bus
BP01	High pressure sensor	XD11	Booster heater power supply (optional/cylinder)
BP03	Low pressure sensor	XD20	Terminal
BP05	High pressure (HP) pressure switch	XD21	L block terminal
BP10	Heating circuit (water) pressure sensor	XD22	N block terminal
BP11	Air differential pressure sensor	XD23	3-pin terminal
BP12	Air differential pressure sensor 2	XD24	4-pin terminal
BP16	Signal anode pressure switch	XD27	CAN bus programming unit connector
BT01	Heating flow temperature sensor - PT 1000	XD76	Diverter valve connector (alternative)
BT02	Heating return temperature sensor - PT 1000	XD77	Integral sensor connector
BT11	Temperature sensor, flow - HP - Pt1000	XD78	Supply air fan connector
BT12	Temperature sensor, return - HP - Pt1000	XD79	Extract air fan connector
BT20	DHW cylinder temperature sensor	XD80	Heat pump fan connector
BT21	DHW cylinder top temperature sensor (optional)	XE03	Clamping plate earth connection for external
BT22	DHW cylinder integral temperature sensor (optional)	XE08	Temperature sensor earth terminal
BT27	2nd DHW cylinder DHW sensor (optional)	XE09	Temperature sensor earth terminal
BT29	Solar collector temperature sensor	XE12	Control panel earth connection
BT30	Outside temperature sensor	XE15	Clamping plate earth connection
BT35	Extract air temperature sensor	XE16	Lower control panel earth connection
BT40	Temperature sensor, hot gas - PT 1000	XE17	Cylinder earth connection
BT42	Temperature sensor, condenser (frost protection)	AA02-X1	Connector X1, temperature sensor, 8-pin
BT43	Temperature sensor, evaporator discharge	AA02-X2	Connector X2, temperature sensor, 12-pin
BT44	Temperature sensor, defrost end (evaporator inlet)	AA02-X3	Connector X3, circulation pump / ext. pumps
BT45	Evaporator discharge temperature sensor - PT 1000	AA02-X4	Connector X4, LV input: Pressure and humidity sensor, float switch
BT46	Compressor intake temperature sensor - PT 1000	AA02-X5	Connector X5, pressure transducer HP/LP
BT48	Oil sump temperature sensor	AA02-X51	Connector X51, flow sensor
BT51	Compressor temperature limiter	AA02-X6	Modbus connection
BT55	High limit safety cut-out for MFG	AA02-X7	Connector X7, CAN bus
BT56	Temperature controller, booster heater 2 kW (optional)	AA02-X8	Connector X8, CAN BUS, programming unit
BT57	High limit safety cut-out for 2 kW booster heater (optional)	AA02-X9	Connector X9, stepper motor
EB01	Booster heater MFG	AA02-X10	Connector X10 EXV, evaporator
EB02	Booster heater cylinder BGC 2 kW (optional)	AA02-X11	Connector X11 EXV, heat pipe
EB03	Oil sump heater	AA02-X12	Connector X12, supply air fan
FC01	Inverter fuse	AA02-X13	Connector X13, extract air fan
FC07	Condensate pump fine-wire fuse	AA02-X14	Connector X14, heat pump fan
KF01	Compressor contactor	AA02-X15	Connector X15, input
KF27	Passive cooling contactor	AA02-X16	Connector X16, mains power
MA01	Compressor motor	AA02-X17	Connector X17, output 1
MA04	Motor, electronic expansion valve, evaporator	AA02-X18	Connector X18, output 2
MA06	Motor, electronic expansion valve, heat pipe	AA02-X19	Connector X19, compressor
MA07	Diverter valve, defrost	AA02-X20	Connector X20, DHC input/output
MA10	Circulation pump motor	AA02-X22	Connector X22, air differential pressure sensor
MA13	Motor, condensate pump, bottom plate	AA02-X23	Connector X23, air differential pressure sensor 2
MA15*	Diverter valve motor (heating/DHW/alternative)	AA02-X24	Connector X24, temperature sensor
MA16	Diverter valve motor (cooling)	AA02-X25	USB port / Service plug
MA20	Motor, heat pump fan		
MA21	Motor, supply air fan		
MA22	Motor, extract air fan		
RF01	Interference suppression filter		

INSTALLATION Specification

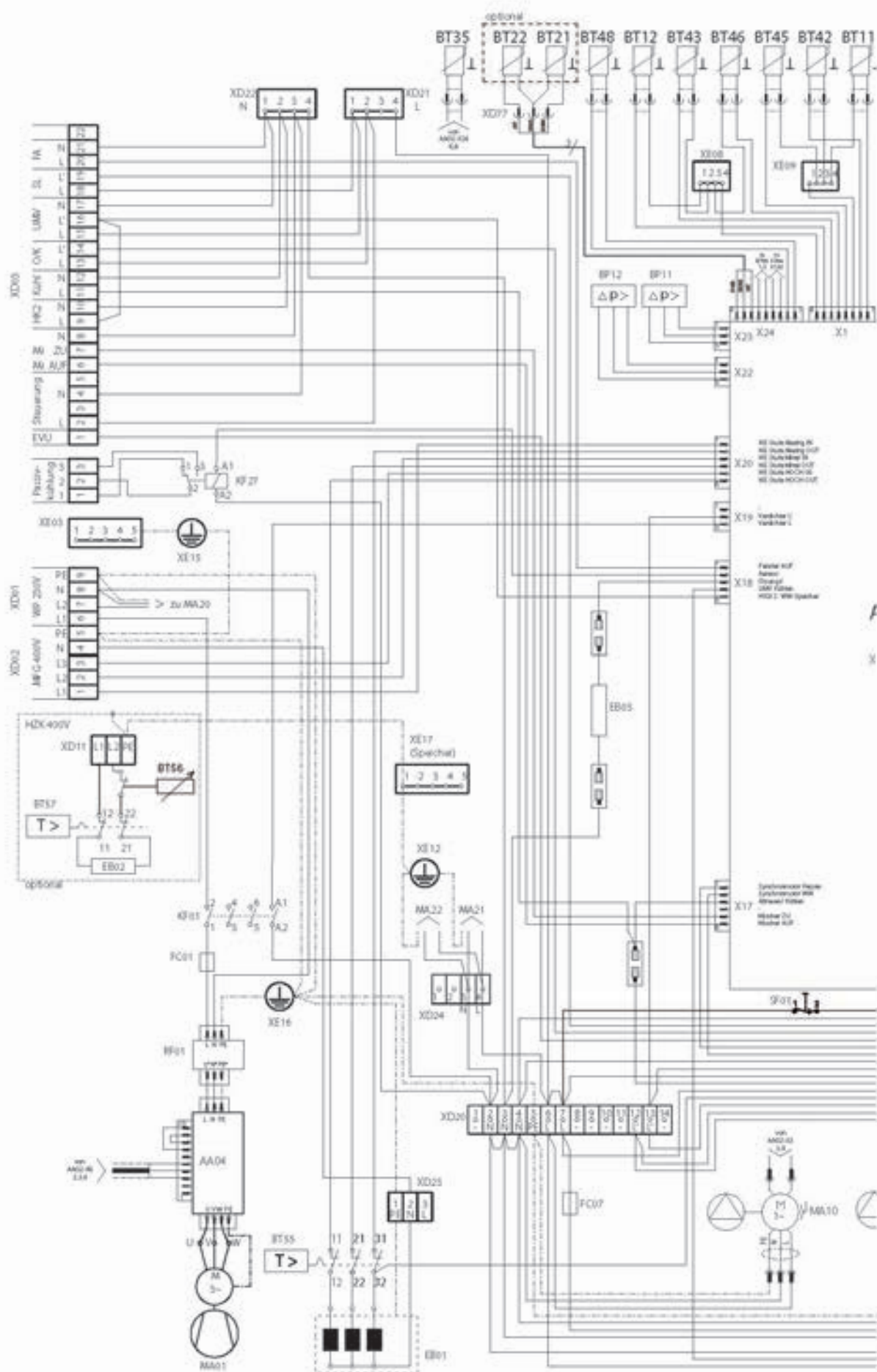

10.6 Output graph

LWZ 5 CS Premium

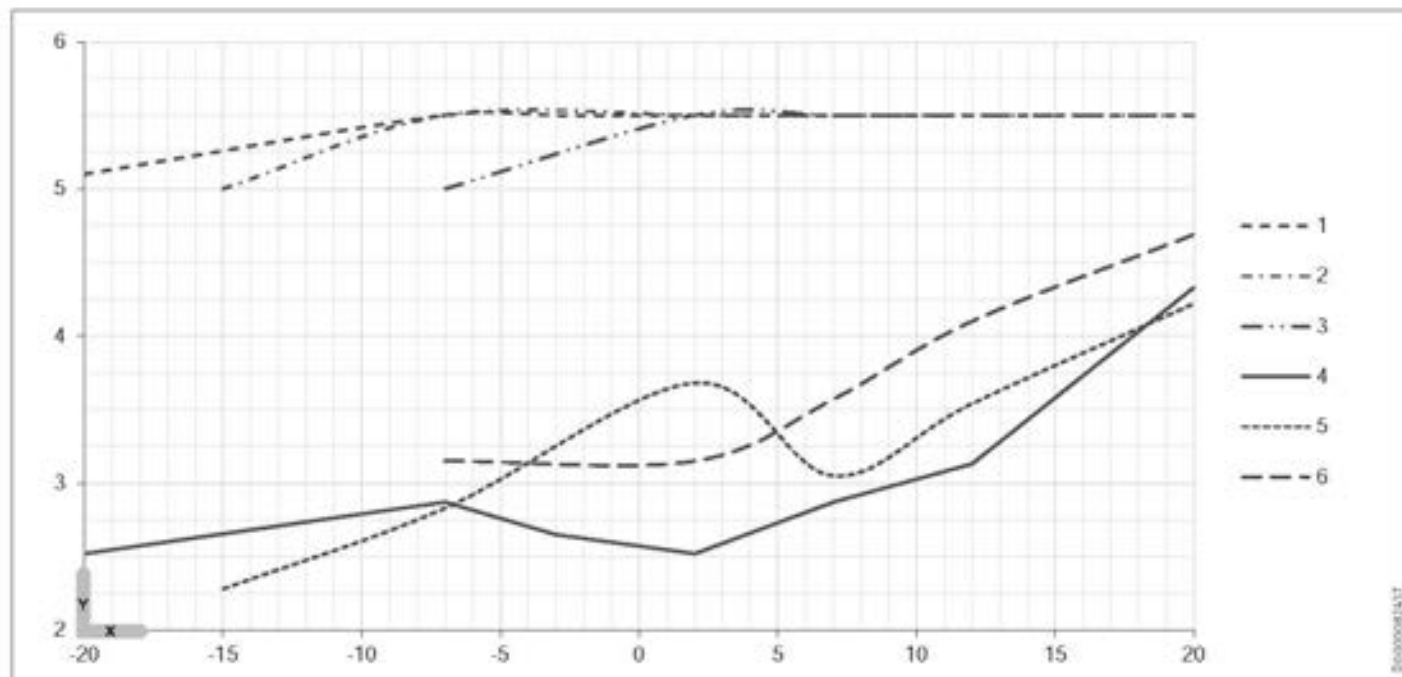

X Outside temperature [°C]
Y Heating output [kW]
1 max. W35
2 max. W45

3 max. W55
4 min. W35
5 min. W45
6 min. W55

LWZ 8 CS Premium

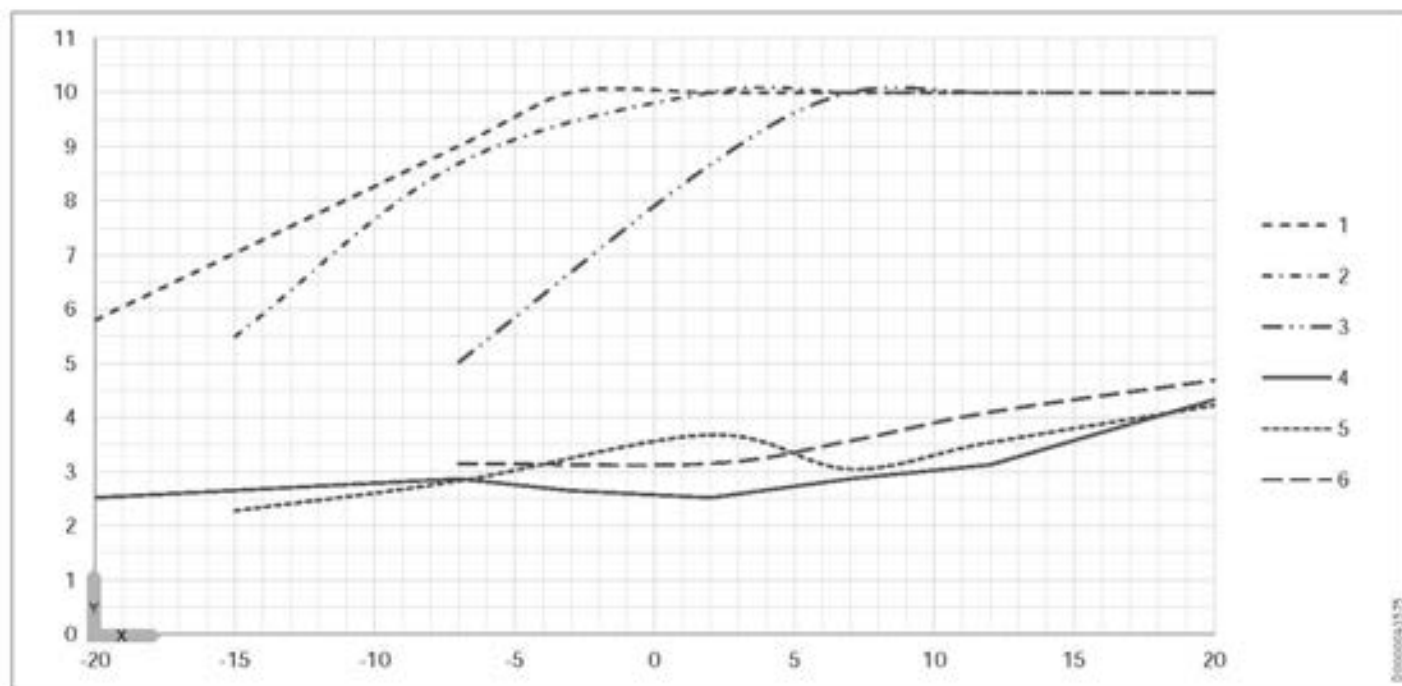

X Outside temperature [°C]
Y Heating output [kW]
1 max. W35
2 max. W45

3 max. W55
4 min. W35
5 min. W45
6 min. W55

10.7 Available external head of the circulation pump

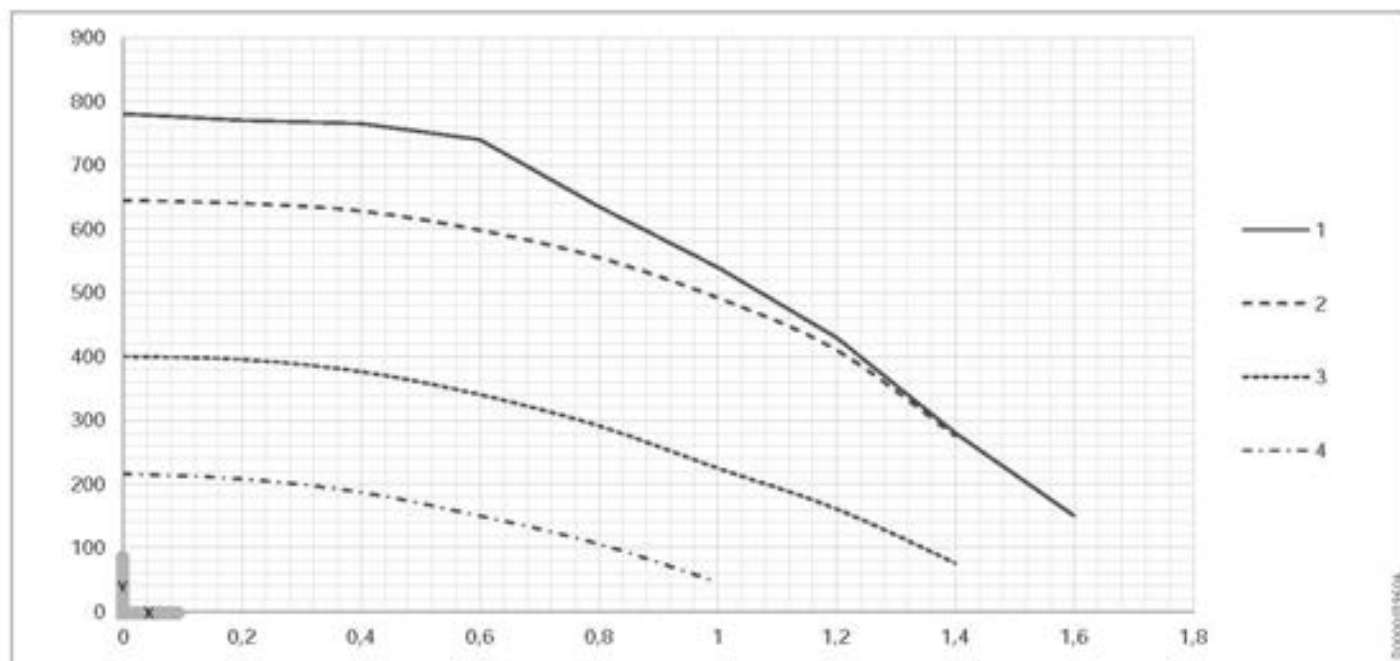

X Flow rate [m³/h]
Y Pressure [hPa]
1 Pump rate 100 %

2 Pump rate 85 %
3 Pump rate 65 %
4 Pump rate 45 %

10.8 Fan curve

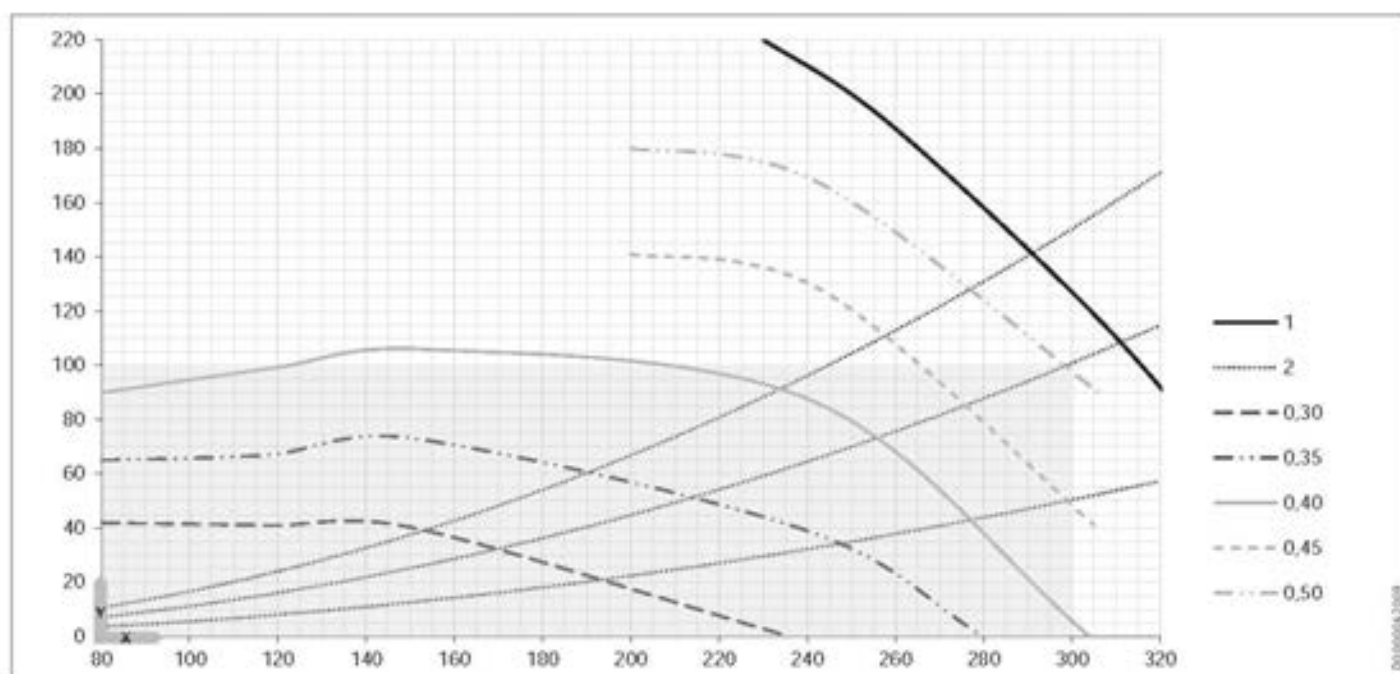

Application range
X Air flow rate [m³/h]
Y Average value, static pressure [Pa]
1 Maximum fan curve
2 System curves

0.30 Specific power consumption 0.30 Wh/m³
0.35 Specific power consumption 0.35 Wh/m³
0.40 Specific power consumption 0.40 Wh/m³
0.45 Specific power consumption 0.45 Wh/m³
0.50 Specific power consumption 0.50 Wh/m³
0.55 Specific power consumption 0.55 Wh/m³

INSTALLATION Specification

10.9 Data table

The output data refers to new appliances with clean heat exchangers. The power consumption of the integral auxiliary drives represents the maximum value and may vary subject to operating point. The power consumption of the integral auxiliary drives is included in the output details of the appliance (to EN 14511).

		LWZ 5 CS Premium 201427	LWZ 8 CS Premium 201290
Heating output			
Heating output at A-7/W35 (EN 14511)	kW	5.50	8.34
Heating output at A2/W35 (EN 14511)	kW	5.16	5.16
Heating output at A7/W35 (EN 14511)	kW	4.40	4.40
Heating output, emergency/booster heater	kW	2.9 / 5.8 / 8.8	2.9 / 5.8 / 8.8
Cooling capacity at A35/W7	kW	2.40	2.69
Max. heating output	kW	14.3	17.2
Power consumption			
Power consumption at A-7/W35 (EN 14511)	kW	3.19	3.19
Power consumption at A2/W35 (EN 14511)	kW	1.38	1.38
Power consumption at A7/W35 (EN 14511)	kW	0.93	0.93
Coefficient of performance			
COP at A-7/W35 (EN 14511)		2.61	2.61
COP at A2/W35 (EN 14511)		3.74	3.74
COP at A7/W35 (EN 14511)		4.74	4.74
Sound emissions			
Sound power level (EN 12102)	dB(A)	50	50
Sound power level, full load (EN 12102)	dB(A)	59	59
Application limits			
Min. application limit, heat source	°C	-20	-20
Max. application limit, heat source	°C	35	35
Max. pressure drop, outdoor air	Pa	25	25
Min. installation room volume	m ³	7	7
DHW temperature with heat pump at A2	°C	50	50
Hydraulic data			
Cylinder capacity	l	235	235
Energy data			
Energy efficiency class, heat pump W55		A++	A++
Energy efficiency class for DHW heating with load profile XL		A	A
Energy efficiency class for DHW heating (load profile), moderate climate		A (XL)	A (XL)
Energy efficiency class		A++/A++	A++/A++
Electrical data			
Max. power consumption, fan	W	170	170
Nominal power consumption, fan	W	100	100
Power consumption, fan	W	100	100
Power consumption, circulation pump	W	< 45	< 45
Max. power consumption without emergency/booster heater	kW	5.3	5.3
Fuse protection, emergency/booster heater	A	3 x B 16	3 x B 16
Max. fuse protection, compressor	A	1 x B 25	1 x B 25
Compressor fuse protection	A	1 x B 16	1 x B 25
Fuse protection, heat pump fan	A	1 x B 16	1 x B 16
Control unit fuse protection	A	B 16	B 16
Rated voltage, emergency/booster heater	V	400	400
Rated voltage, compressor	V	230	230
Rated voltage, heat pump fan	V	230	230
Rated voltage, control unit	V	230	230
Compressor phases		1/N/PE	1/N/PE
Heat pump fan phases		1/N/PE	1/N/PE
Control unit phases		1/N/PE	1/N/PE
Frequency	Hz	50	50
Total power consumption	A	20	20
Starting current (with/without starting current limiter)	A	-/8	-/8
Emergency/booster heater phases		3/N/PE	3/N/PE

INSTALLATION Specification

		LWZ 5 CS Premium	LWZ 8 CS Premium
Versions			
Refrigerant		R410A	R410A
Refrigerant charge	kg	2.95	2.95
CO ₂ equivalent (CO ₂ e)	t	6.16	6.26
Global warming potential of the refrigerant (GWP100)		2088	2088
IP rating		IP1XB	IP1XB
Filter class, extract air		ISO Coarse > 60 % (G4)	ISO Coarse > 60 % (G4)
Filter class, supply air		ePM10 ≥ 50 % (M5)	ePM10 ≥ 50 % (M5)
Filter class, outdoor air		ISO Coarse > 30 % (G2)	ISO Coarse > 30 % (G2)
Application range, living space	m ²	< 220	< 220
Dimensions			
Height when tilted	mm	2020	2020
Height	mm	1885	1885
Width	mm	1430	1430
Depth	mm	812	812
Weights			
Weight, function module	kg	263	263
Weight, cylinder module	kg	177	177
Weight, empty	kg	420	420
Weight, full	kg	670	670
Connections			
Heating connection		DN 22	DN 22
DHW connection		DN 22	DN 22
Solar circuit connection		DN 22	DN 22
Supply air/extract air connection		DN 160	DN 160
Condensate drain	mm	22	22
Outdoor air/exhaust air connection	mm	410x155 oval	410x155 oval
Heating water quality requirements			
Water hardness	°dH	≤3	≤3
Conductivity (softening)	µS/cm	<1000	<1000
Conductivity (desalination)	µS/cm	20-100	20-100
Chloride	mg/l	<30	<30
Oxygen 8-12 weeks after filling (softening)	mg/l	< 0.02	< 0.02
Oxygen 8-12 weeks after filling (desalination)	mg/l	< 0.1	< 0.1
pH value (with aluminium fittings)		8.0-8.5	8.0-8.5
pH value (without aluminium fittings)		8.0-10.0	8.0-10.0
Values			
Heat recovery level up to	%	90	90
Heating flow rate (EN 14511) at A7/W35, B0/W35 and S K	m ³ /h	1.3	1.3
Min. heating flow rate	m ³ /h	0.7	0.7
Supply air/extract air flow rate	m ³ /h	80-300	80-300
Nominal air flow rate	m ³ /h	240	240
Outdoor air/exhaust air flow rate	m ³ /h	1000	1000
Available external pressure, ventilation at 230 m ³ /h	Pa	100	100
Available external pressure, outdoor air/exhaust air	Pa	50	50
Safety valve, DHW	MPa	1	1
Max. flow temperature	°C	60	60
Safety valve, heating	MPa	0.3	0.3
Expansion vessel volume	l	15	15
Expansion vessel pre-charge pressure	MPa	0.075	0.075
Min. living area, active cooling (without buffer cylinder)	m ²	40	40
Min. flow rate, cooling (without buffer cylinder)	m ³ /h	0.7	0.7

You can use the „Starting current limiter“ parameter to limit the power consumption of the compressor. The parameter can be found in the menu „CONTRACTOR / REFRIGERATION UNIT“.

Further details

		LWZ 5 CS Premium	LWZ 8 CS Premium
		201427	201290
Maximum altitude for installation	m	2000	2000