

INSTALLER INSTRUCTIONS

CONTENTS

1	DESCRIPTION OF THE BOILER	pag.	60
2	INSTALLATION	pag.	64
3	CHARACTERISTICS	pag.	74
4	USE AND MAINTENANCE	pag.	78

IMPORTANT

When carrying out commissioning of the boiler, you are highly recommended to perform the following checks:

- Make sure that there are no liquids or inflammable materials in the immediate vicinity of the boiler.
- Make sure that the electrical connections have been made correctly and that the earth wire is connected to a good earthing system.
- Open the gas tap and check the soundness of the connections, including that of the burner.
- Make sure that the boiler is set for operation for the type of gas supplied.
- Check that the flue pipe for the outlet of the products of the combustion is unobstructed and has been properly installed.
- Make sure that any shutoff valves are open.
- Make sure that the system is charged with water and is thoroughly vented.
- Check that the circulating pump is not locked.
- Purge the system, bleeding off the air present in the gas pipe by operating the pressure relief valve on the gas valve inlet.
- The installer must provide the user with instruction in operation of the boiler and safety devices and hand over the instruction booklet to the user.

FONDERIE SIME S.p.A. of Via Garbo 27 - Legnago (VR) - Italy declares that its hot water boilers, which bear the CE mark under Gas Directive 90/396/CEE and are fitted with a safety thermostat calibrated to a maximum of 110°C, **are not subject** to application of PED Directive 97/23/CEE as they meet the requirements of article 1 paragraph 3.6 of the Directive.

1 DESCRIPTION OF THE BOILER

1.1 INTRODUCTION

“FORMAT DGT 25/15 BF” are the gas fuelled burner groups for heating and the production D.H.W. ready to use thanks to

micro-tank.

They are apparatuses which conform to the European directives 2009/142/CE, 2004/108/CE, 2006/95/CE and 92/42/CE.

The can be fuelled by natural gas (G20) or LPG (G30-G31).

The instructions given in this manual are provided to ensure proper installation and perfect operation of the appliance.

1.2 DIMENSION

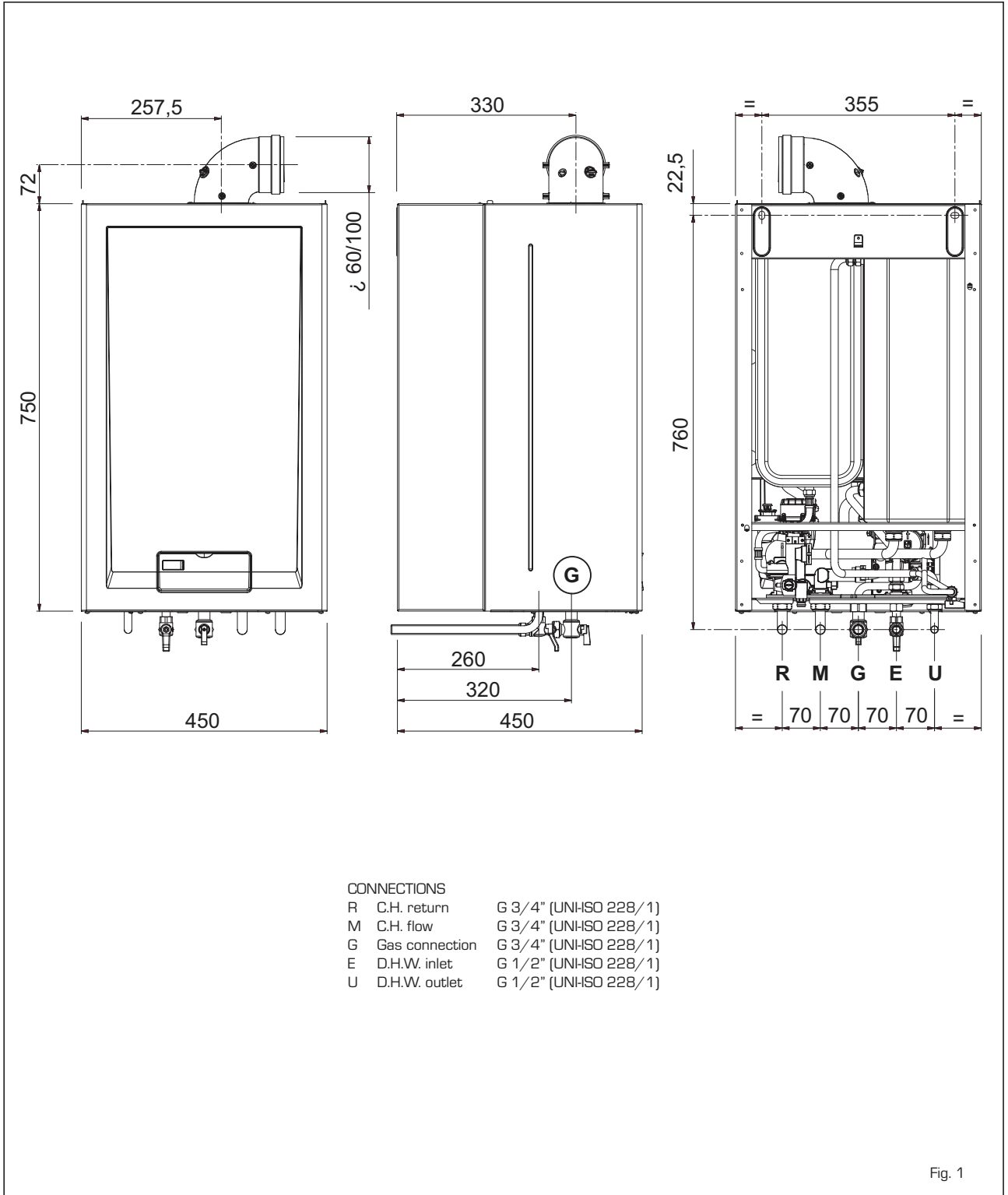

Fig. 1

1.3 TECHNICAL FEATURES

ES

PT

ENG

Model		FORMAT DGT 25/15 BF	
Heat output			
Nominal	kW	23,6	
Reduced	kW	7,5	
Heat input			
Nominal	kW	25,5	
Reduced	kW	9,2	
Thermal yield 100% useful		93,0	
Thermal yield useful at 30% of load		90,5	
Thermal efficiency (CEE 92/42 directive)		★★★	
Losses after shutdown to 50°C (EN 483)	W	82	
Supply voltage	V-Hz	230-50	
Adsorbed power consumption	W	110	
Electrical protection grade	IP	X5D	
C.H. setting range	°C	40÷80	
Water content boiler	l	6,1	
Maximum water head	bar	3	
Maximum temperature	°C	85	
Capacity of the heating expansion vessel	l	8	
Pressure of the heating expansion vessel	bar	1,2	
D.H.W. setting range	°C	10÷60	
D.H.W. flow rate (EN 625)	l/min	11,3	
Continuous D.H.W. flow rate Δt 30°C	l/min	11,7	
D.H.W. pressure min/max	bar	0,5/7,0	
Micro-tank capacity	l	15	
Smokes temperature min/max	°C	94/116	
Smokes flow min/max	g/s	17/16	
CE certification	n°	1312BU5372	
Category		II ₂ H ₃ + / II ₂ HM ₃ +	
Type of appliance		B ₂₂ P-52P/C ₁₂ -32-42-52-62-82	
NO_x emission class		3 (< 150 mg/kWh)	
Weight when empty	kg	37	
Main burner nozzle			
Quantity nozzles	n°	11	
Nozzle diameter G20	mm	1,30	
Nozzle diameter G30/G31	mm	0,80	
Gas consumption *			
Natural gas (G20)	m ³ /h	2,70	
LPG (G30/G31)	kg/h	2,01	
Burner gas pressure min/max			
Natural gas (G20)	mbar	1,9/13,5	
Butane (G30)	mbar	3,7/27,9	
Propane (G31)	mbar	3,7/35,9	
Gas supply pressure			
Natural gas (G20)	mbar	20	
Butane (G30)	mbar	28-30	
Propane (G31)	mbar	37	

* Gas consumption figures express the lowest calorific power of pure gas under standard conditions at 15°C - 1013 mbar; this figure may differ from the actual figure, which is dependent on gas composition and environmental conditions.

1.4 FUNCTIONAL DIAGRAM

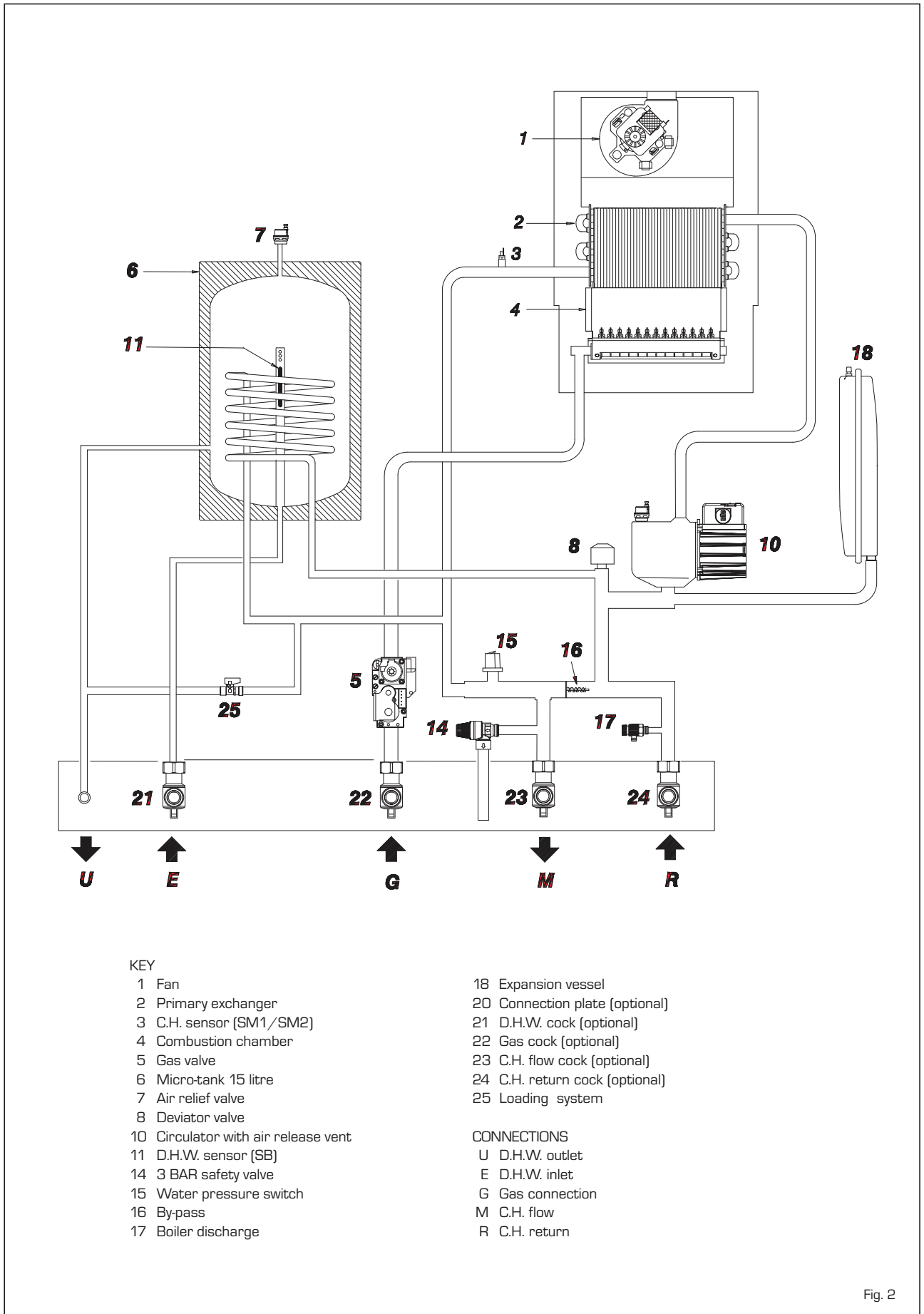

KEY

- | | |
|-------------------------------------|--------------------------------|
| 1 Fan | 18 Expansion vessel |
| 2 Primary exchanger | 20 Connection plate (optional) |
| 3 C.H. sensor (SM1/SM2) | 21 D.H.W. cock (optional) |
| 4 Combustion chamber | 22 Gas cock (optional) |
| 5 Gas valve | 23 C.H. flow cock (optional) |
| 6 Micro-tank 15 litre | 24 C.H. return cock (optional) |
| 7 Air relief valve | 25 Loading system |
| 8 Deviator valve | |
| 10 Circulator with air release vent | |
| 11 D.H.W. sensor (SB) | |
| 14 3 BAR safety valve | |
| 15 Water pressure switch | |
| 16 By-pass | |
| 17 Boiler discharge | |

CONNECTIONS

- U D.H.W. outlet
- E D.H.W. inlet
- G Gas connection
- M C.H. flow
- R C.H. return

Fig. 2

1.5 MAIN COMPONENTS

ES
PT
ENG

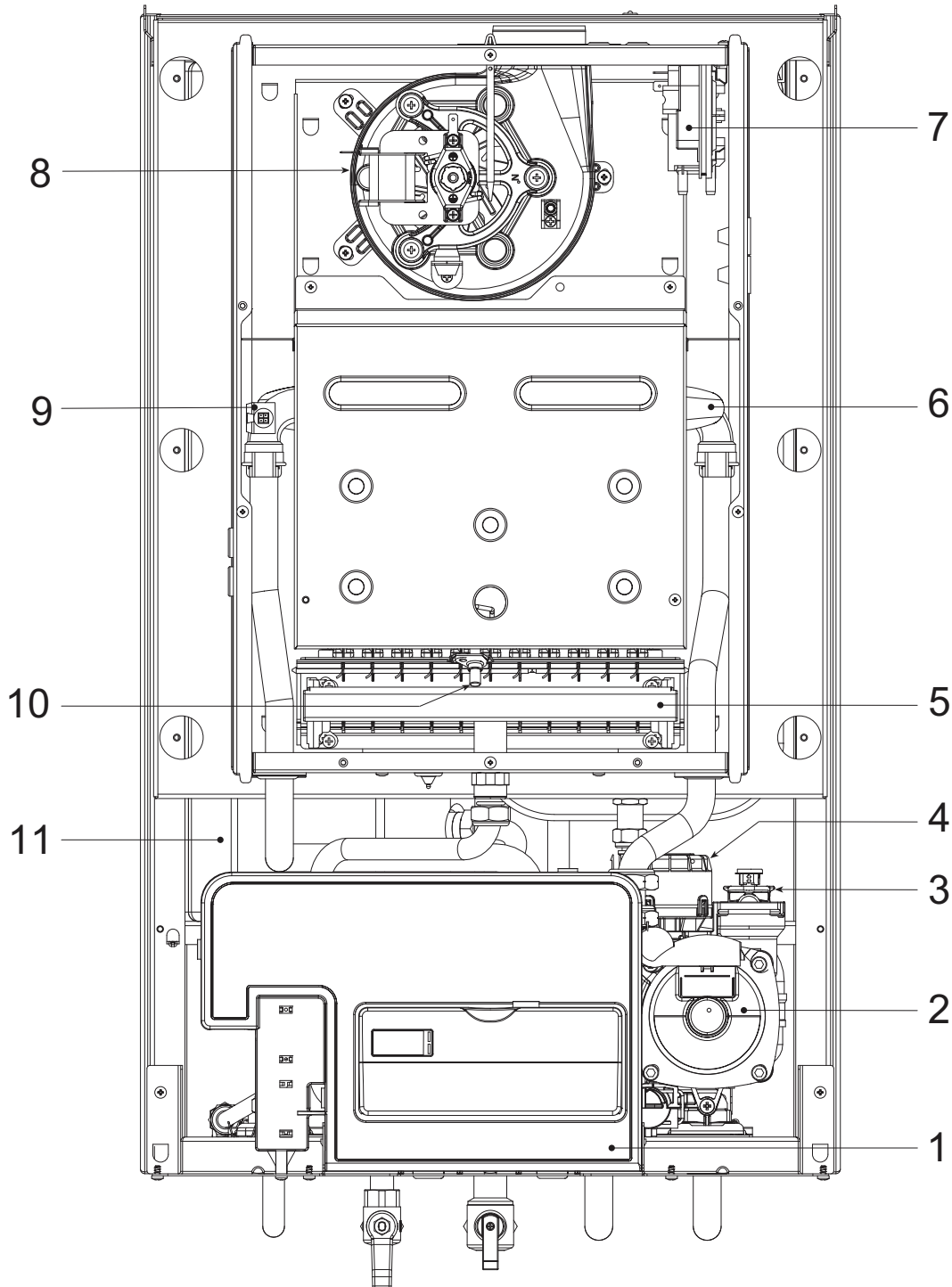

- | | |
|--------------------|---------------------------------|
| 1 Control panel | 6 Primary exchanger |
| 2 Circulation pump | 7 Air pressure switch |
| 3 Air relief valve | 8 Fan |
| 4 Deviator valve | 9 C.H. sensor (SM1/SM2) |
| 5 Burners | 10 Ignition/detection electrode |
| | 11 Micro-tank 15 litre |

Fig. 3

2 INSTALLATION

The boiler must be installed in a fixed location and only by specialized and qualified firms in compliance with all instructions contained in this manual. Furthermore, the installation must be in accordance with current standards and regulations.

2.1 INSTALLATION

- In the rooms where “type B” boilers are installed, the air required for correct combustion of the gas consumed by the appliance must be able to flow in. It is therefore necessary to make openings that cannot be blocked in the outer walls, which must be at least 6 cm² for every kW of thermal capacity installed and with, in any case, a minimum of 100 cm².
- “Type C” appliances, with combustion chamber and air supply sealed off from the environment, can be installed in any room in the house.
- “Type B and C” boilers are suitable for functioning in a partially protected place, as according to EN 297, with maximum environmental temperature of 60°C and minimum of -5°C. We recommend installation of these boilers under the protruding slope of a roof, on a balcony, or in a protected niche, always providing they are not directly exposed to adverse weather (rain, hail, snow). The boilers are provided already equipped with anti-freeze functions.

2.1.1 Anti-freeze function

The boilers are equipped with anti-freeze function which activates the pumps and the burner when the temperature of the water contained inside the appliance drops to below value PAR 10. The anti-freeze function is ensured, however, only if:

- the boiler is correctly connected to the gas and electricity supply circuits;
- the boiler is constantly fed;
- the boiler ignition is not blocked;
- the essential components of the boiler are all in working order

In these conditions the boiler is protected against frost down to an environmental temperature of -5°C.

ATTENTION: In the case of installation in a place where the temperature drops below 0°C, the connection pipes must be protected.

2.2 COMPLEMENTARY ACCESSORIES

To facilitate connecting the boiler to the system, the following accessories can be supplied on request, complete with instructions for assembly:

- Installation plate code 8075427
- Elbows and gas taps/sanitary water out-

put set code 8075418

- Taps kit code 8091806
- Polyphosphates doser kit code 81071700
- Kit of couplings for replacing wall-hung boilers of other makes code 8093900

2.3 CONNECTING UP SYSTEM

To protect the heat system from damaging corrosion, incrustation or deposits, before installation it is extremely important to clean the system using suitable products such as, for example, **Sentinel X300 (new systems), X400 and X800 (old systems) or Fernox Cleaner F3**.

Complete instructions are provided with the products but, for further information, you may directly contact SENTINEL PERFORMANCE SOLUTIONS LTD or FERNOX COOKSON ELECTRONICS. For long-term protection against corrosion and deposits, the use of inhibitors such as **Sentinel X100 or Fernox Protector F1** is recommended after cleaning the system. It is important to check the concentration of the inhibitor after each system modification and during maintenance following the manufacturer's instructions (specific tests are available at your dealer).

The safety valve drain must be connected to a collection funnel to collect any discharge during interventions. If the heating system is on a higher floor than the boiler, install the on/off taps supplied in kit optional on the heating system delivery/return pipes.

WARNING: Failure to clean the heat system or add an adequate inhibitor invalidates the device's warranty.

Gas connections must be made in accordance with current standards and regulations.

When dimensioning gas pipes from the

meter to the module, both capacity volume (consumption) in m³/h and gas density must be taken into account.

The sections of the piping making up the system must be such as to guarantee a supply of gas sufficient to cover the maximum demand, limiting pressure loss between the gas meter and any apparatus being used to not greater than:

- 1.0 mbar for family II gases (natural gas);
- 2.0 mbar for family III gases (butane or propane).

An adhesive data plate is stuck inside the front panel; it contains all the technical data identifying the boiler and the type of gas for which the boiler is arranged.

2.3.1 Filter on the gas pipe

The gas valve is supplied ex factory with an inlet filter, which, however, is not adequate to entrap all the impurities in the gas or in gas main pipes. To prevent malfunctioning of the valve, or in certain cases even to cut out the safety device with which the valve is equipped, install an adequate filter on the gas pipe.

2.5 SYSTEM FILLING

Filling of the boiler and the system is done by the system filling (10 fig. 4).

The charge pressure, with the system cold, must be between **1 and 1.2 bar**.

Filling must be done slowly so as to allow any air bubbles to be bled off through the air valves.

Should the pressure have risen well above the limit expected, discharge the over pressure by opening the pressure-relief valve.

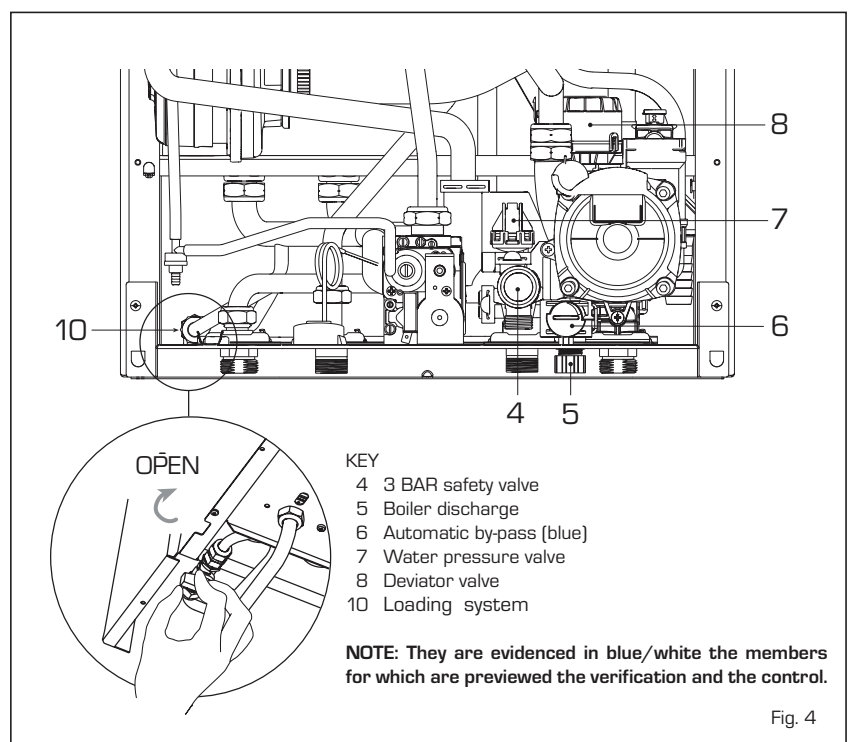

Fig. 4

2.5.1 Emptying the system

Use the drain tap to empty the system (5 fig. 4). Turn off the boiler before doing this.

2.6 FLUES/CHIMNEYS

A chimney or flue for the evacuation of the combustion products into the atmosphere must correspond to the requisites prescribed by the laws in force.

In particular, the specific prescriptions of law relative to boilers with natural draught in collective pipes (type B) and those for boilers with forced draught (type C) must be respected.

2.6.1 Ducting of existing chimneys

To recover or duct existing chimneys, ducts declared suitable for the purpose by the manufacturer must be used, and the installation and use modalities indicated by the said manufacturer must also be followed as well as the prescriptions of Standard UNI 10845.

2.7 INSTALLATION OF COAXIAL DUCT

2.7.1 Accessories 60/100

The 60/100 coaxial duct is supplied on request in kit code 8084811.

The diagrams of fig. 5 illustrate some examples of different types of discharge modalities allowed and the maximum lengths that can be reached.

2.7.2 Diaphragm for 60/100 coaxial duct

The boiler is supplied with a diaphragm of $\varnothing 79$. Use the diaphragms according to the indications of fig. 5/a.

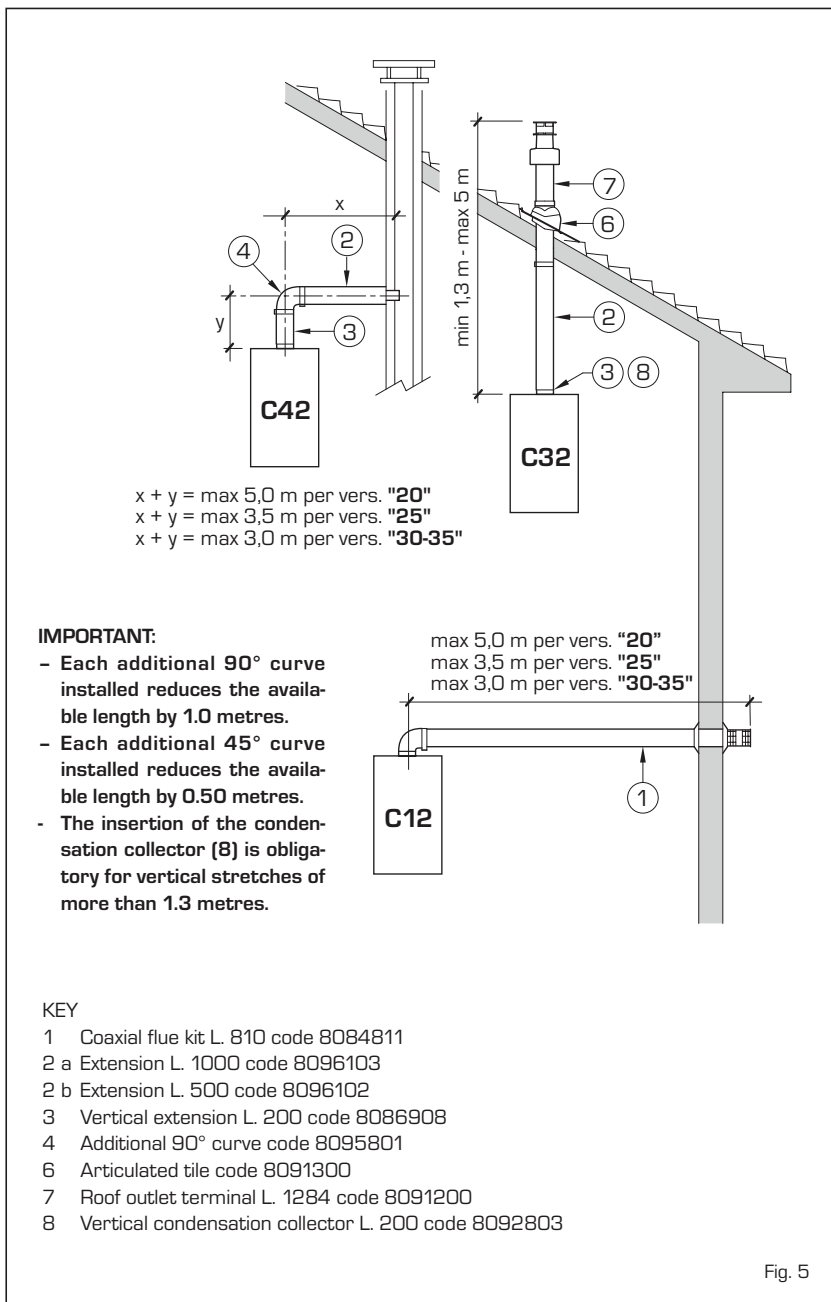

For discharge types C12-C42, use the diaphragms supplied with the boiler $\varnothing 79.0$ only when the length of the coaxial duct is less than 1 metre.

For discharge types C32, use the following diaphragms according to the length of the duct and without additional curves $\varnothing 79$ in this mode:

Installations with vertical extension L. 200 code 8086908 *		Installations with vertical condensation collector code 8092803 *	
Models "25/15 BF"		Models "25/15 BF"	
Diaphragm $\varnothing 79$	Without diaphragm	Diaphragm $\varnothing 79$	Without diaphragm
L max = 2,5 m	L max = 5 m	L max = 2,5 m	L max = 5 m

* Minimum length of duct L = 1.3 m.

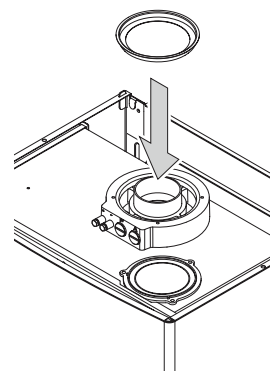

Fig. 5/a

2.7.3 Accessories ø 80/125

The ø 80 coaxial duct is supplied on request in a kit code 8084830 complete with assembly instructions.

With the curve supplied in the kit, the maximum horizontal length of the duct must be no more than 6 metres.

The diagrams in fig. 6 show some examples of the different types of ø 80/125 coaxial discharge modalities.

2.8 INSTALLATION OF SEPARATE DUCTS

When installing, the provisions of the laws in force must be adhered to, as well as certain practical suggestions:

- With aspiration directly from outside, when the duct is longer than 1 metre, it is advisable to insulate the said duct in order to avoid the formation of dew on the outside of the pipe when the weather

is particularly cold.

- With ducts with discharge positioned outside the building, or in cold environments, insulation is necessary to avoid difficulty in starting the burner. In these cases, a condensation system on the pipes must be provided for.
- If the pipe passes through inflammable walls, insulate the stretch of the fumes discharge pipe that passes through the wall with rounded glass wool 30 mm

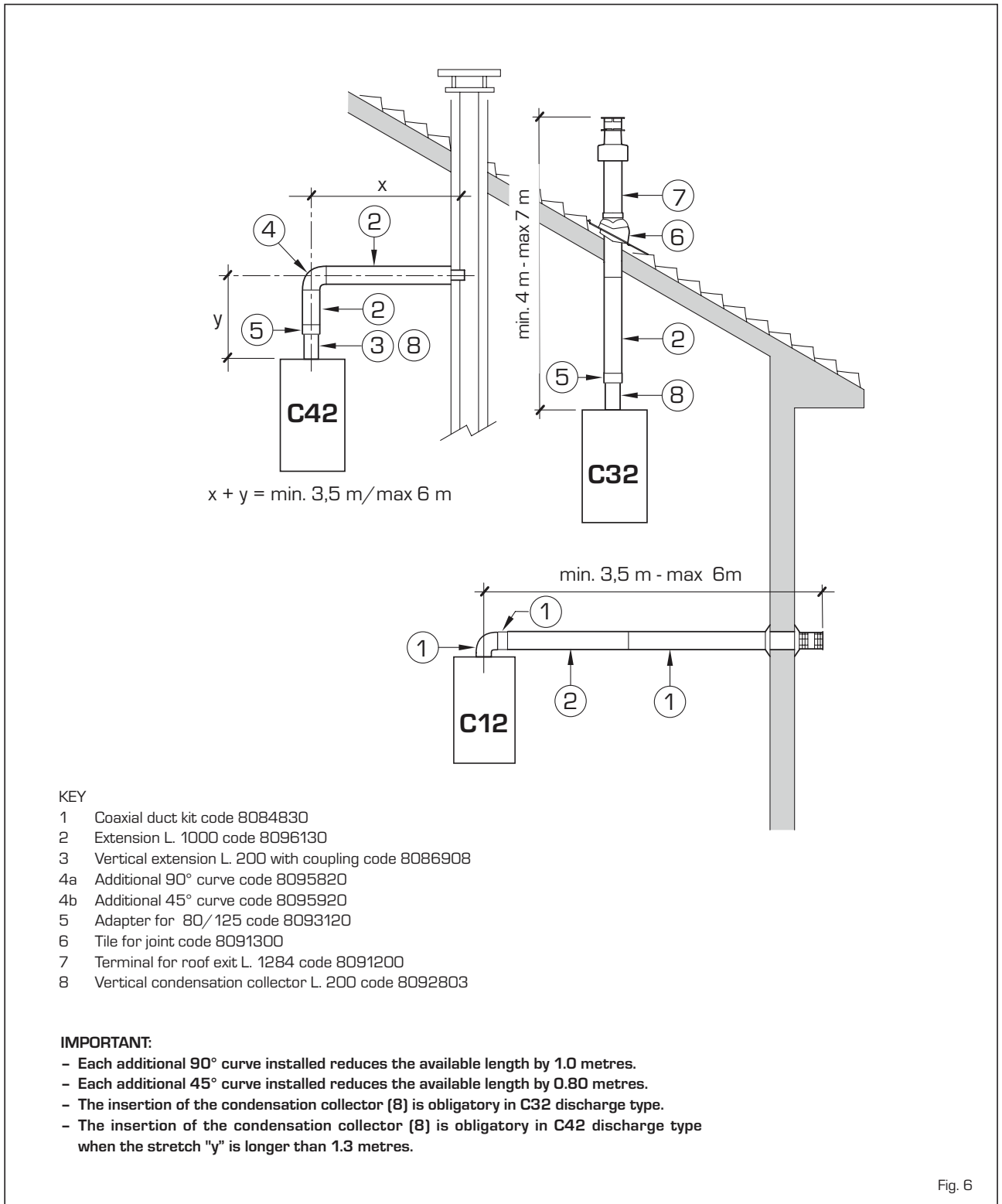

Fig. 6

thick and with a density of 50 kg/m².

The maximum total length, which is the sum of lengths of the aspiration and discharge pipes, is determined by the loss of charge of the single accessories inserted and must not result as more than 9.0 mm H₂O.

For the loss of charge of the accessories, refer to **Table 1** and to the example given in fig. 7.

2.8.1 Air/combustion products divider

The air/combustion products divider cod. 8093020 (fig. 8) is supplied with the aspiration diaphragm that must be engaged, depending on the maximum head loss accepted in both ducts, as indicated in fig. 8/a.

2.8.2 Outlet systems

The diagrams in fig. 9 illustrate a number of examples of different types of separate outlets.

TABLE 1

Accessories ø 80	Load loss (mmH ₂ O)	
	25/15 BF	
	Intake	Outlet
90° elbow MF	0,35	0,40
45° elbow MF	0,30	0,35
Extension L. 1000 (horizontal)	0,20	0,30
Extension L. 1000 (vertical)	0,20	0,10
Wall terminal	0,15	0,50
T-shaped condensation collector	–	0,80
Roof exit terminal*	1,60	0,10

* The loss of the roof exit terminal in aspiration concludes the collector code 8091400

Calculation example of the head loss of a "25/15 BF" vers. boiler (installation allowed as the sum of the head losses of the accessories used is less than 9.0 mmH₂O):

	Intake	Outlet
7 meter horizontal pipe ø 80 x 0.20	1.40	–
7 meter horizontal pipe ø 80 x 0.30	–	2.10
No. 2 90° elbows ø 80 x 0.35	0.70	–
No. 2 90° elbows ø 80 x 0.40	–	0.80
No. 1 wall terminal ø 80	0.15	0.50
Total head loss	2.25	+ 3.40 = 5.65 mmH₂O

With this total head loss, remove the segments from No. 1 to No. 6 from diaphragm in the intake pipe.

Fig. 7

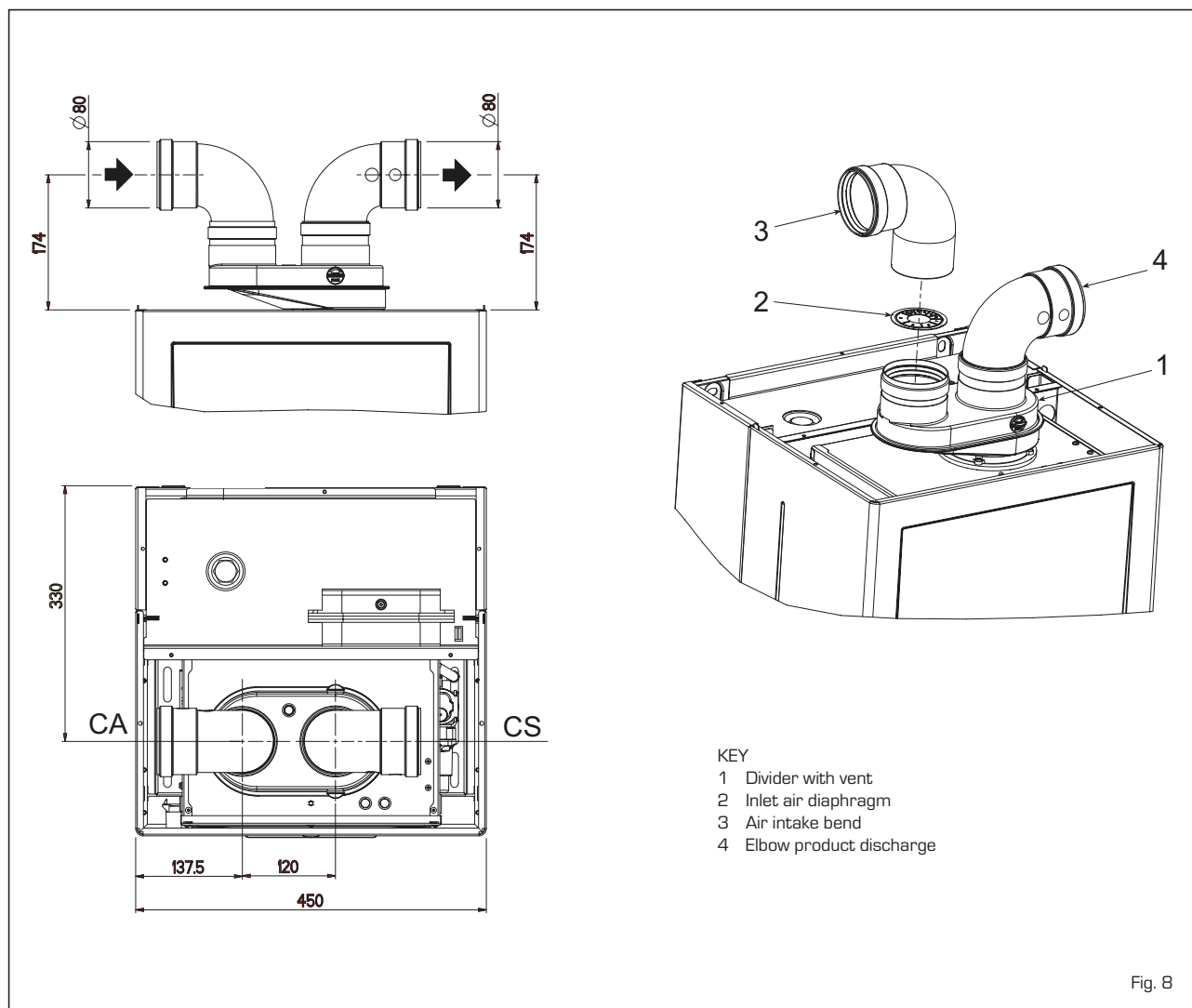

Fig. 8

No. segments to remove	Total load loss mm H ₂ O
	25/15 BF
none	0 ÷ 2,0
No. 1	2,0 ÷ 3,0
No. 1 and 2	3,0 ÷ 4,0
from n° 1 to 3	-
from n° 1 a 4	4,0 ÷ 5,0
from n° 1 a 5	-
from n° 1 a 6	5,0 ÷ 6,0
from n° 1 a 7	6,0 ÷ 7,0
from n° 1 a 8	-
from n° 1 a 9	7,0 ÷ 8,0
from n° 1 a 10	-
without diaphragm	8,0 ÷ 9,0

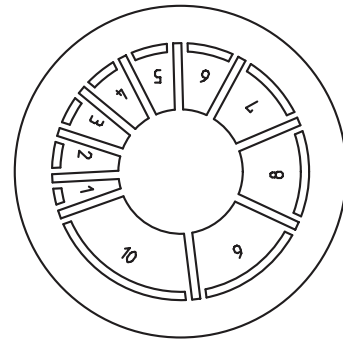

Fig. 8/a

2.9 FORCED EXHAUST (Type B22P-B52P)

Comply with the following requirements during installation:

- Insulate the exhaust pipe and install a condensation collection system at the base of the vertical pipe.
- If the pipe passes through combustible walls, insulate the section of the flue pipe

passing through the wall with a 30 mm thick fibreglass pipe covering with a density of 50 kg/m³.

This type of exhaust pipe is installed using

CONFIGURATION C62: discharge and aspiration is by means of pipes available on sale and certified separately (the pressure loss in the ducts must be calculated according to the Standard UNI EN 13384)

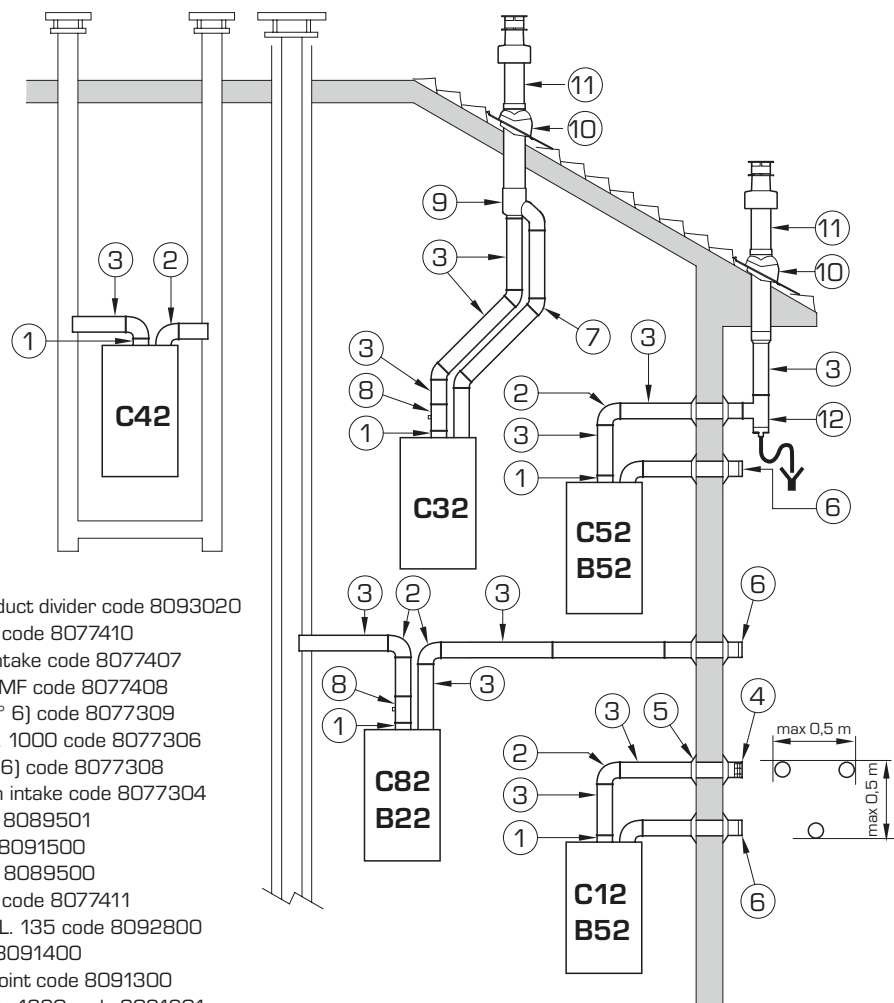

KEY

- 1 Air/combustion product divider code 8093020
- 2a 90° elbow MF (n° 6) code 8077410
- 2b 90° elbow MF with intake code 8077407
- 2c Isolated 90° elbows MF code 8077408
- 3a Extension L. 1000 (n° 6) code 8077309
- 3b Insulated extension L. 1000 code 8077306
- 3c Extension L. 500 (n° 6) code 8077308
- 3d Extension L. 135 with intake code 8077304
- 4 Outlet terminal code 8089501
- 5 Int.-est. ring kit code 8091500
- 6 Intake terminal code 8089500
- 7 45° elbow MF (n° 6) code 8077411
- 8 Condensation outlet L. 135 code 8092800
- 9 Doubler fitting code 8091400
- 10 Tile with articulated joint code 8091300
- 11 Roof outlet terminal L. 1390 code 8091201
- 12 Tee condensation outlet code 8093300

IMPORTANT: In type C52 the outlet and inlet flues must not come out on opposite walls.

Fig. 9

the special kit, code 8093020. For kit assembly instructions, refer to point 2.8.1. Protect the intake with the optional accessory, code 8089501 (fig. 10). The air/combustion product divider code 8093020 is supplied with aspiration diaphragm that must be engaged, depending on the maximum head loss allowed, as indicated in fig. 8/a.

Maximum flow resistance must be no more than 9.0 mm H₂O.

As the maximum pipe length is determined by adding up the flow resistance of the various individual accessories installed, refer to **Table 1** for calculation.

2.10 POSITIONING OF OUTLET TERMINALS

The outlet terminals for forced draught systems may be located on the outer walls of the building **Table 2** shows approximate, non-binding minimum distances to be met for a building of the type shown in fig. 11.

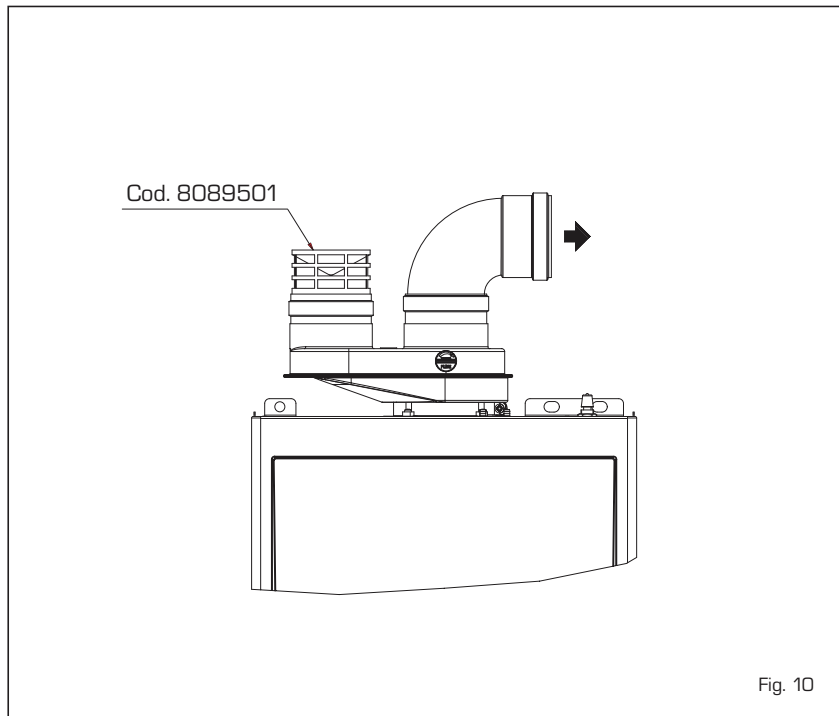

Fig. 10

ES

PT

ENG

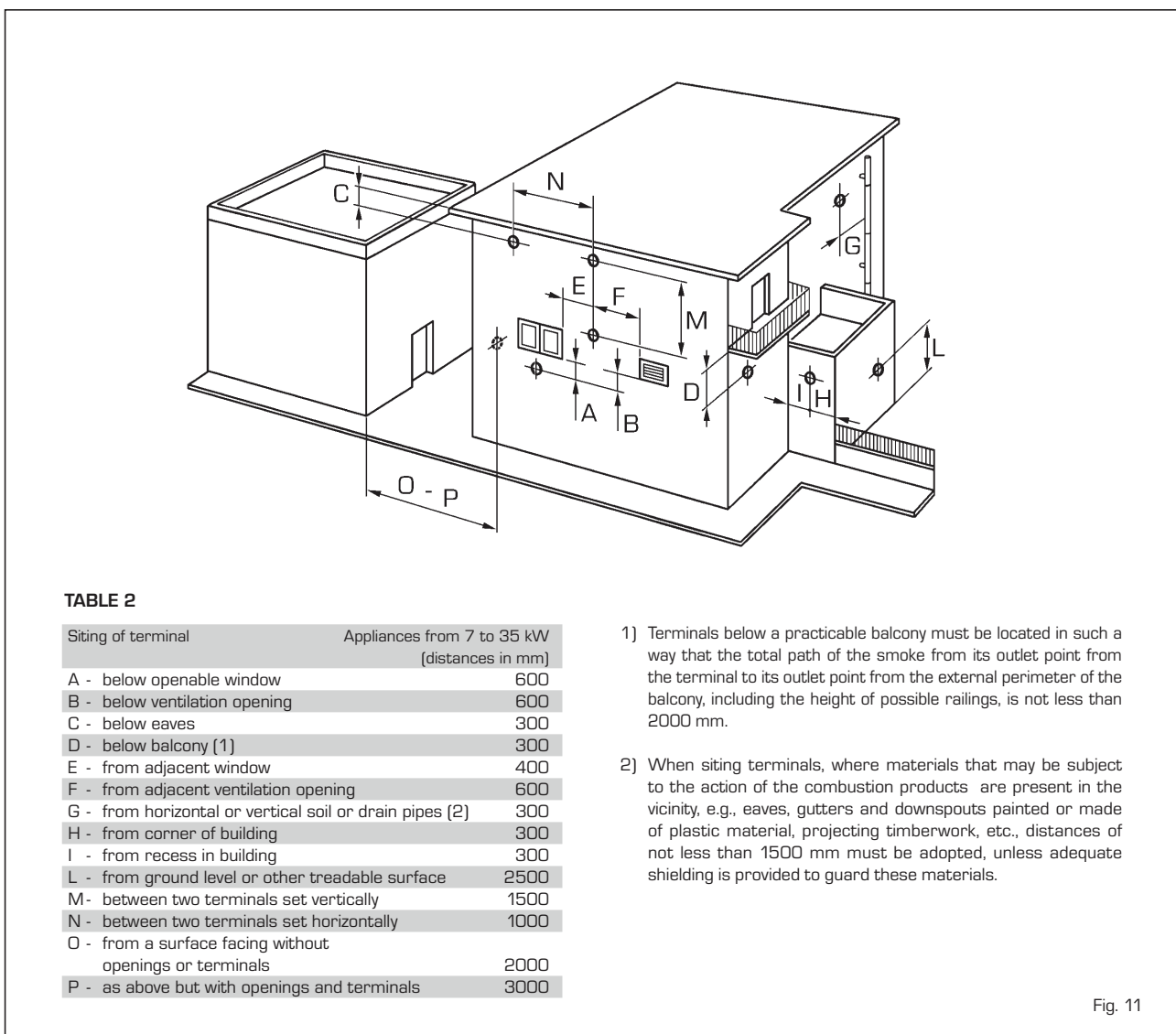

TABLE 2

Siting of terminal	Appliances from 7 to 35 kW (distances in mm)
A - below openable window	600
B - below ventilation opening	600
C - below eaves	300
D - below balcony (1)	300
E - from adjacent window	400
F - from adjacent ventilation opening	600
G - from horizontal or vertical soil or drain pipes (2)	300
H - from corner of building	300
I - from recess in building	300
L - from ground level or other treadable surface	2500
M - between two terminals set vertically	1500
N - between two terminals set horizontally	1000
O - from a surface facing without openings or terminals	2000
P - as above but with openings and terminals	3000

- 1) Terminals below a practicable balcony must be located in such a way that the total path of the smoke from its outlet point from the terminal to its outlet point from the external perimeter of the balcony, including the height of possible railings, is not less than 2000 mm.
- 2) When siting terminals, where materials that may be subject to the action of the combustion products are present in the vicinity, e.g., eaves, gutters and downspouts painted or made of plastic material, projecting timberwork, etc., distances of not less than 1500 mm must be adopted, unless adequate shielding is provided to guard these materials.

Fig. 11

2.11 ELECTRICAL WIRING

If you must replace the electric power cable supplied with the boiler, order it exclusively from Sime.

The power supply must be single-phase 230V - 50 Hz through a main switch protected by a fuse with a distance of at least 3 mm between contacts.

NOTE: The boiler must be connected with an efficient grounding system. SIME shall not be held liable for injury or damage resulting from failure to ground the boiler.

ATTENTION: Before every intervention on the boiler, cut off the electricity supply by means of the main switch of the system, since even if the boiler is "OFF", the electrical panel remains connected to the electricity.

2.11.1 Chronothermostat connection

Remove the boiler casing, tilt the control panel and connect the chronothermostat to the 6 pole terminal board as indicated in the boiler electrical diagram (see paragraph 2.12) after having removed the existing bridge.

The chronothermostat to be used must be of a class conforming to the standard EN 60730.1 (clean electrical contact).

2.11.2 Remote control CR 63 connection (optionals)

The boiler is designed for connection to a remote control unit CR 63 code 8092219 coupled to an optional expansion kit code 8092240.

The remote control unit allows for complete

remote control of the boiler, except release of the boiler:

When the connection has been made the boiler display will show the following message: **Cr**.

For installation and use of the remote control, follow the instructions in the package.

2.11.3 External sensor connection (optional)

The boiler is designed for connection to an external temperature sensor, supplied on request (code 8094101), which can automatically regulate the temperature value of the boiler output according to the external temperature.

For installation, follow the instruction in the package. It is possible to make corrections to the values read by the drill acting on the **PAR 4**.

2.11.4 Use with different electronic systems

Some examples are given below of boiler systems combined with different electronic systems. The electrical connections to the boiler refer to the wording on the diagrams (fig. 13). The zone valve control starts at every demand for heating of the remote control.

Description of the letters indicating the components shown on the system diagrams:

M	System output
R	System return
CR	Remote control CR 63
SE	External temperature sensor
TA 1-2	Zone room thermostat
VZ 1-2	Zone valve
RL 1-2	Zone relay
SI	Hydraulic separator
P 1-2	Zone pump
IP	Floor system
EXP	Expansion card (code 6301430)
VM	thermostatic mixer valve
TSB	Safety thermostat low temperature

1 BASIC SYSTEM

SYSTEM WITH A DIRECT ZONE AND ROOM THERMOSTAT, OR WITH A REMOTE CONTROL (Code 8092219), KIT EXPANSION REMOTE CONTROL (Code 8092240) AND EXTERNAL SENSOR (Code 8094101)

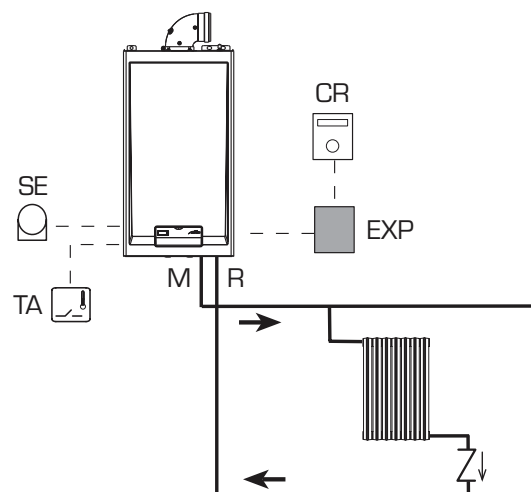

2 BASIC SYSTEM

MULTI-ZONE SYSTEM WITH VALVE, ROOM THERMOSTAT AND EXTERNAL SENSOR (Code 8094101)

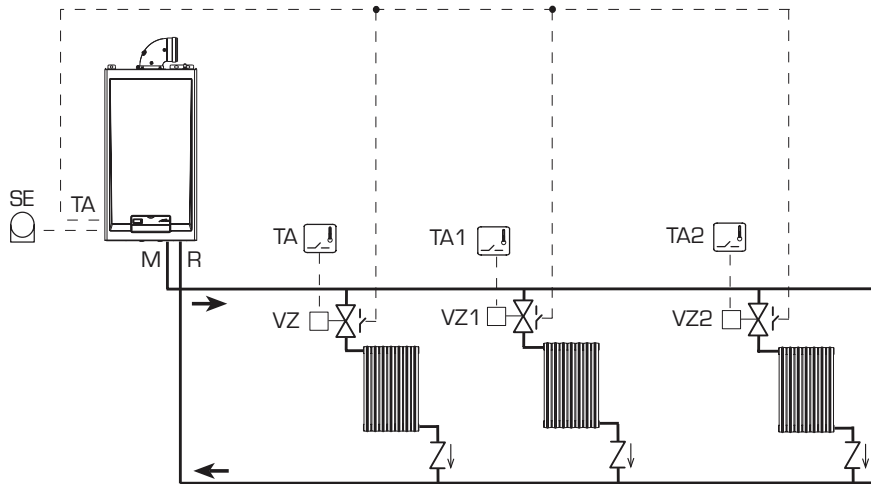

3 BASIC SYSTEM

MULTI-ZONE SYSTEM WITH PUMP, ROOM THERMOSTATS AND EXTERNAL SENSOR (Code 8094101)

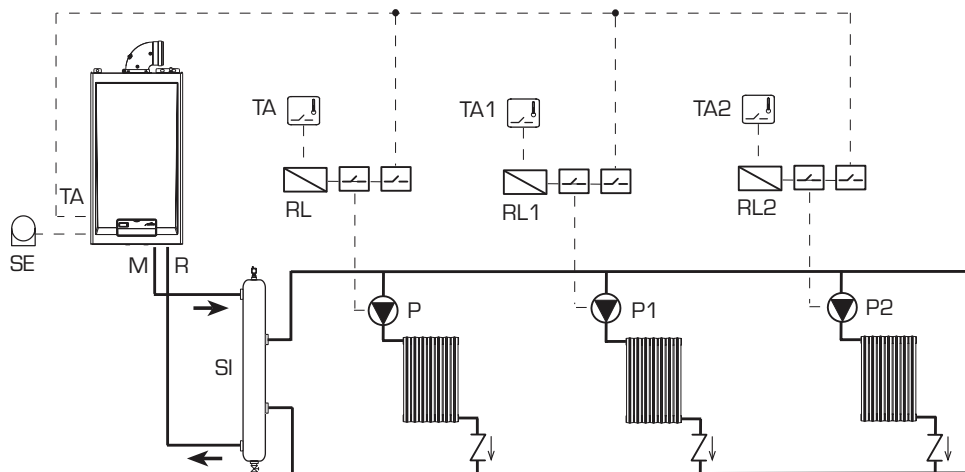

4 BASIC SYSTEM

MULTI-ZONE SYSTEM WITH VALVE, ROOM THERMOSTATS, REMOTE CONTROL (Code 8092219), KIT EXPANSION REMOTE CONTROL (Code 8092240) AND EXTERNAL SENSOR (Code 8094101)

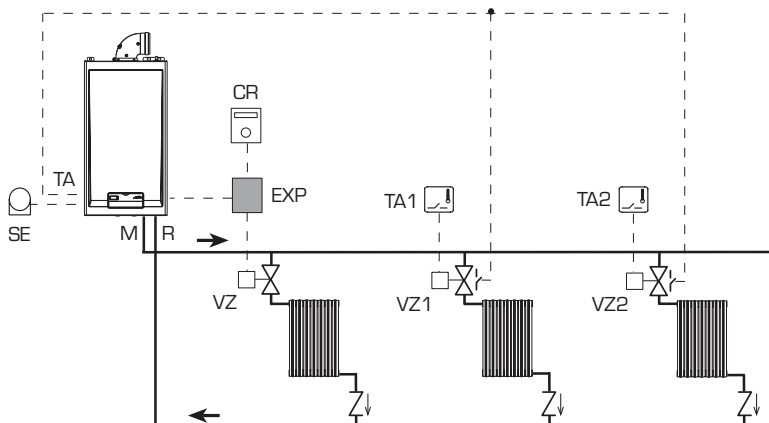

PARAMETERS SETTINGS

Set the opening time of the VZ zone valve:

PAR 17 = SYSTEM PUMP ACTIVATION DELAY

5 BASIC SYSTEM

MULTI-ZONE SYSTEM WITH PUMPS, ROOM THERMOSTATS, REMOTE CONTROL (Code 8092219), KIT EXPANSION REMOTE CONTROL (Code 8092240) AND EXTERNAL SENSOR (Code 8094101)

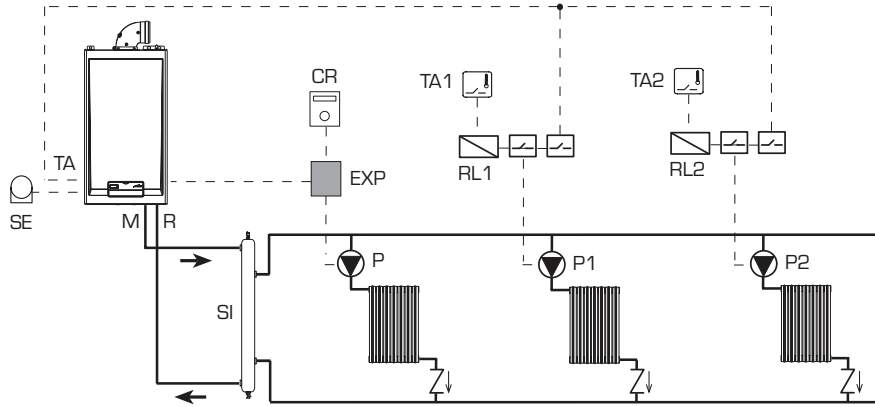

NOTE:

The heating is set from the remote control for the first zone and from the boiler panel for the other zones. If there is a request for heat at the same time, the boiler is activated at the highest temperature setting.

6 MIXER VALVE SYSTEM

SYSTEM WITH ONE DIRECTED ZONE, AND ONE MIXER ZONE

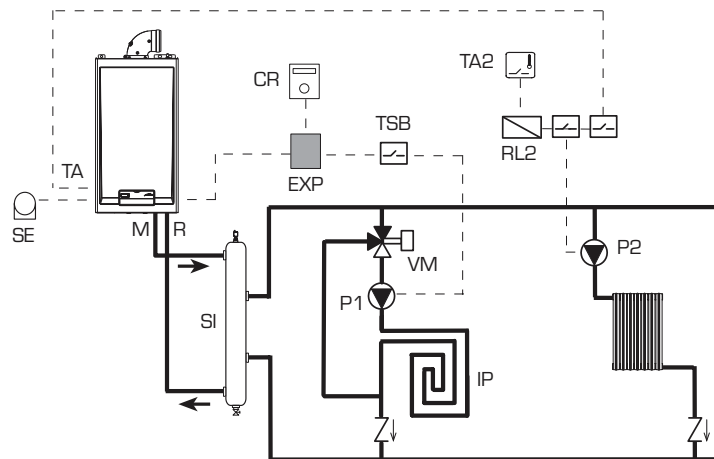

2.12 BOILER ELECTRICAL DIAGRAM

ES
PT
ENG

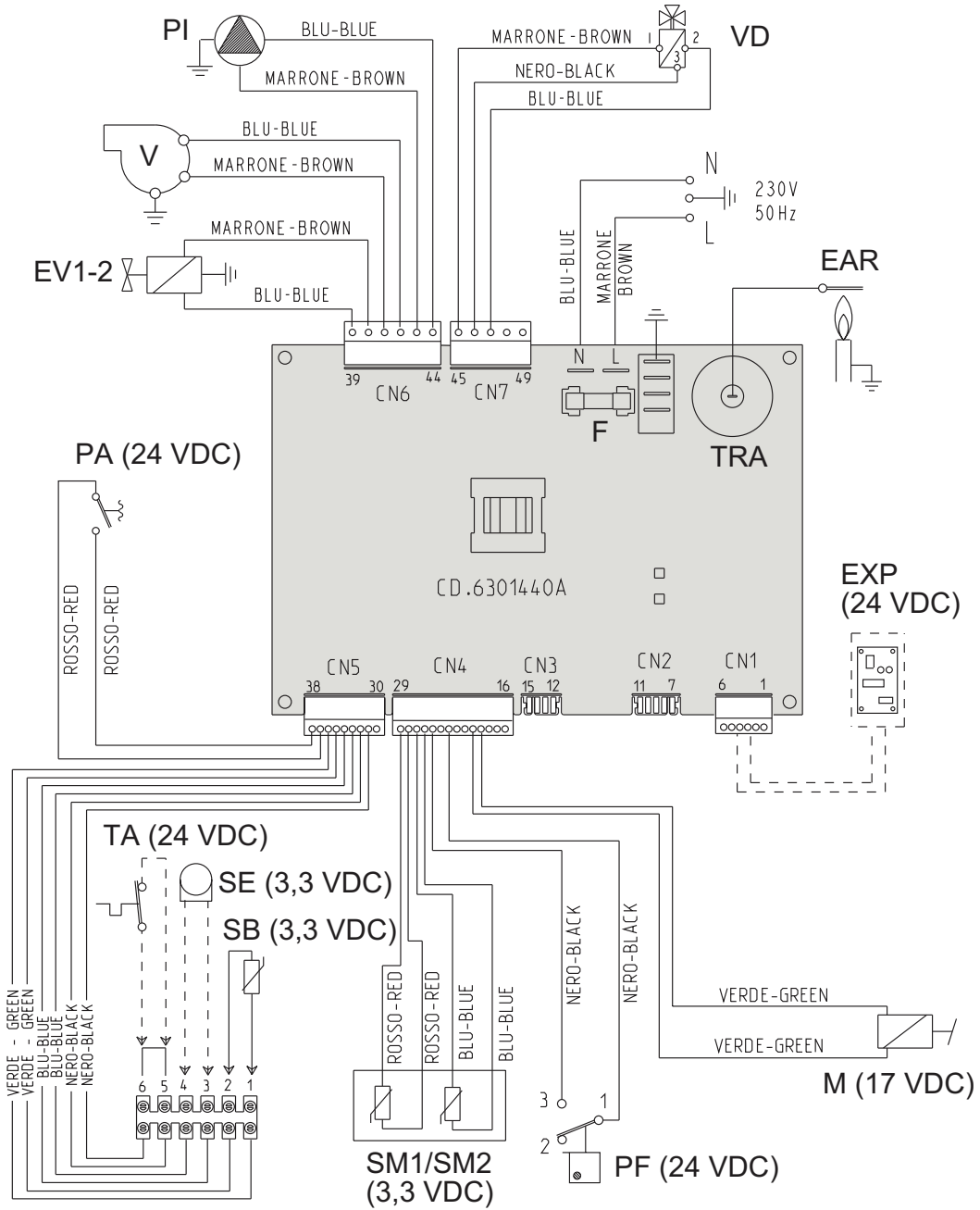

- KEY**
- F Fuse [1.6 AT]
 - TRA Ignition transformer
 - PI System pump
 - V Fan
 - EAR Ignition/detection electrode
 - EV1-2 Gas valve coil
 - PF Smoke thermostat
 - M Modulator
 - SM1/SM2 Heating sensor
 - FLM D.H.W. flow meter
 - VD Deviator valve
 - PA Water pressure valve
 - TA Environment thermostat

- SE External sensor (optional)
- SB D.H.W. sensor
- EXP Expansion card remote control (optional)

NOTE: Connect TA to the clamps 5-6 after having removed the bridge.

CONNECTOR SPARE PART CODES:

- CN4** code 6319112
- CN5** code 6316253
- CN6** code 6316252
- CN7** code 6316278







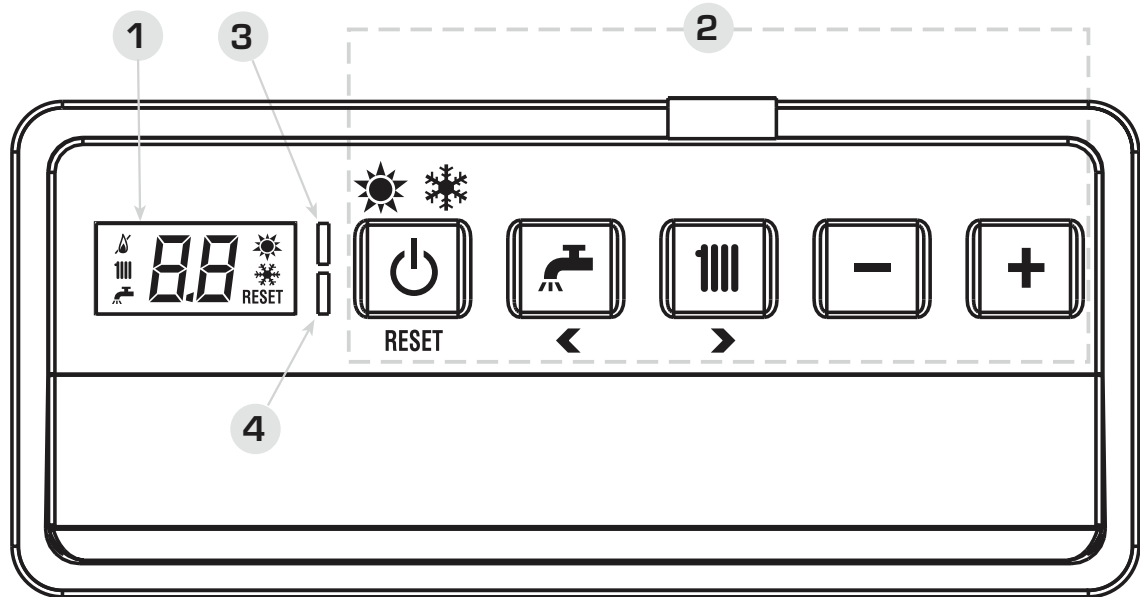

Fig. 13

3 CHARACTERISTICS





3.1 CONTROL PANEL



1 - DESCRIPTION OF DISPLAY ICONS

-  SUMMER MODE ICON
-  WINTER MODE ICON
-  D.H.W. MODE ICON
-  HEATING MODE ICON
-  FUNCTIONING BURNER ICON
-  BLOCK DUE TO NO IGNITION/FLAME DETECTION
-  NECESSITY OF RESET
-  MAIN DIGITS

2 - DESCRIPTION OF CONTROLS

-  **OPERATING MODE/RESET**
By pressing the key in succession, pass to the summer and winter function (stand-by function if permanent on the key more than two second). RESET is only available if a resettable anomaly is signalled
-  **D.H.W. SET**
Press the key to display the D.H.W. temperature value set
-  **HEATING SET**
Press the key to display the heating temperature value set (value not relative to the remote control)
-  **DECREASE**
Pressing this key decreases the value set
-  **INCREASE**
Pressing this key increases the value set

3 - LED GREEN

ON = Indicates the presence of electrical voltage.
It switches off momentarily every time the keys are pressed.
It can be disabled by setting **PAR 3 = 0**.

4 - LED RED

OFF = Regular functioning.
ON = Boiler anomaly signalled.
Flashing when the control panel buttons are pressed inside the **PARAMETERS SECTION**.

Fig. 14

3.2 ACCESS TO INSTALLER'S PARAMETERS

For access to the installer's parameters, press simultaneously the keys of boiler panel (and) for 5 seconds. The red LED flashes and the display shows:



The parameters can be scrolled with or .

To enter the parameter press or . The value set **flashes**, the display shows:



Proceed as follows to change the set value:

- set the new value using or .
- confirm the set value using or .

Press to exit the parameters section. The display is shown automatically after 5 minutes. The parameters section contains the alarms log, info and meters (display only).

3.2.1 Replacing the board or RESETTING parameters

If the electronic board is replaced or reset, it is necessary to configure PAR 01 and PAR 02 by associating the following values to each type of boiler to be able to restart the boiler:

GAS	MODELS	PAR 1
METHANE	25/15 BF	01
	-	02
LPG	25/15 BF	03
	-	04
-	-	05
	-	06
	-	07
	-	08

BOILER	PAR 2
-	1
-	-
-	-
25/15 BF	21

NOTE: the boiler panel has a label with the values that have to be set for PAR 01 and PAR 02 (fig. 21).

PARAMETERS INSTALLER					
FAST CONFIGURATION					
PAR	DESCRIPTION	RANGE	UNIT OF MEASUREMENT	INC/DEC UNIT	DEFAULT SETTING
01	Combustion configuration	- = ND 1 ... 8	=	=	"-"
02	Hydraulic configuration	- = ND 1 ... 22	=	=	"-"
03	Disabling of voltage presence LED	0 = Disabled 1 = Enabled	=	=	01
04	Correction of external probe values	-5 ... 05	°C	1	00
05	Timer block of the keys	- = Disabled 1 ... 99	Min.	1	15
D.H.W. - HEATING					
PAR	DESCRIPTION	RANGE	UNIT OF MEASUREMENT	INC/DEC UNIT	DEFAULT SETTING
10	Boiler antifreeze	0 ... 10	°C	1	03
11	External sensor antifreeze	- = Disabled -9 ... 05	°C	1	-2
12	Climatic curve setting	03 ... 40	=	1	20
13	Minimum temperature heating	40 ... PAR 14	°C	1	40
14	Maximum temperature heating	PAR 13 ... 80	°C	1	80
15	Maximum power heating	30 ... 99	%	1	99
16	Post-circulation time	0 ... 99	10 sec.	1	03
17	Pump heating activation delay	0 ... 99	10 sec.	1	01
18	Re-ignition delay	0 ... 10	Min.	1	03
19	Modulation D.H.W. flowmeter	- = Disabled 1 = Enabled	=	=	01
29	Anti-legionella (only D.H.W. tank)	- = Disabled 50 ... 80	°C	1	"-"
PARAMETERS RE-SET					
PAR	DESCRIPTION	RANGE	UNIT OF MEASUREMENT	INC/DEC UNIT	DEFAULT SETTING
49 *	Reset default parameters (PAR 01 - PAR 02 equal "-")	- , 1	=	=	=
* If the current setting is difficult to understand or anomalous behaviour or if it is difficult to understand the boiler, it is advised to restore the initial parameter values by setting PAR 49 = 1 and PAR 1 and PAR 2 as specified in point 3.2.1.					
ALARMS (visualization)					
PAR	DESCRIPTION	RANGE	UNIT OF MEASUREMENT	INC/DEC UNIT	DEFAULT SETTING
A0	Last code anomaly appearance	=	=	=	=
A1	Code anomaly previously appearance	=	=	=	=
A2	Code anomaly previously appearance	=	=	=	=
A3	Code anomaly previously appearance	=	=	=	=
A4	Code anomaly previously appearance	=	=	=	=
A5	Code anomaly previously appearance	=	=	=	=
A6	Code anomaly previously appearance	=	=	=	=
A7	Code anomaly previously appearance	=	=	=	=
A8	Code anomaly previously appearance	=	=	=	=
A9	Code anomaly previously appearance	=	=	=	=
INFO (visualization)					
PAR	DESCRIPTION	RANGE	UNIT OF MEASUREMENT	INC/DEC UNIT	DEFAULT SETTING
i0	External sensor temperature	-9 ... 99	°C	1	=
i1	C.H. 1 sensor temperature	-9 ... 99	°C	1	=
i2	C.H. 2 sensor temperature	-9 ... 99	°C	1	=
i3	D.H.W. sensor temperature	-9 ... 99	°C	1	=
i4	Auxiliary sensor AUX temperature	-9 ... 99	°C	1	=
i5	Set of effective heating temperature	PAR 13 ... PAR 14	°C	1	=
i6	Level survey flame	00 ... 99	%	1	=
i7	Current to the modulator	00 ... 17	10 mA	1	=
i8	Flow rate D.H.W. flow meter	00 ... 99	l/min	1	=
COUNTERS (visualization)					
PAR	DESCRIPTION	RANGE	UNIT OF MEASUREMENT	INC/DEC UNIT	DEFAULT SETTING
c0	Number hours of operation of the burner	00 ... 99	h x 100	0,1 from 0,0 to 9,9 1 from 10 to 99	00
c1	Number of ignitions of the burner	00 ... 99	x 1000	0,1 from 0,0 to 9,9 1 from 10 to 99	00
c2	Number total of the anomalies	00 ... 99	x 1	1	00
c3	Number approached the parameters installer	00 ... 99	x 1	1	00
c4	Number approached the parameters OEM	00 ... 99	x 1	1	00

3.4 EXTERNAL SENSOR

If there is an external sensor, the heating settings SET can be taken from the climatic curves according to the external temperature and, in any case, limited to with the range values described in point 3.2 (parameters PAR 13 and PAR 14).

The climatic curve to be set can be selected from a value of 3 and 40 (at step 1). Increasing the steepness of the curves of fig. 15 will increase the output temperature as the external temperature decreases.

3.5 CARD FUNCTIONING

The electronic card has the following functions:

- Antifreeze protection of the heating circuit.
- Ignition and flame detection system.
- Control panel setting for the power and the gas for boiler functioning.
- Anti-block for the pump which is fed for a few seconds after 48 hours of inactivity.
- Chimney sweep function which can be activated from the control panel.
- Temperature which can be shifted with the external sensor connected. It can be set from the control panel.
- Automatic regulation of the ignition power and maximum heating. Adjustments are managed automatically by the electronic card to guarantee maximum flexibility in use of the system.
- Interface with the following electronic systems: remote control CR 73 o CR 63, with coupling kit card expansion code 8092240.

3.6 TEMPERATURE DETECTION SENSOR

Table 3 gives the values of the electrical element (Ω) obtained on the heating sensor according to the variations in temperature.

When the heating sensor (SM1/SM2) is interrupted, the boiler will not function for both services.

When the sanitary sensor (SB) is interrupted, the boiler in winter mode will function only heating; and in summer mode will function only sanitary.

TABLE 3

Temperature (°C)	Resistance (Ω)
20	12.090
30	8.313
40	5.828
50	4.161
60	3.021
70	2.229
80	1.669

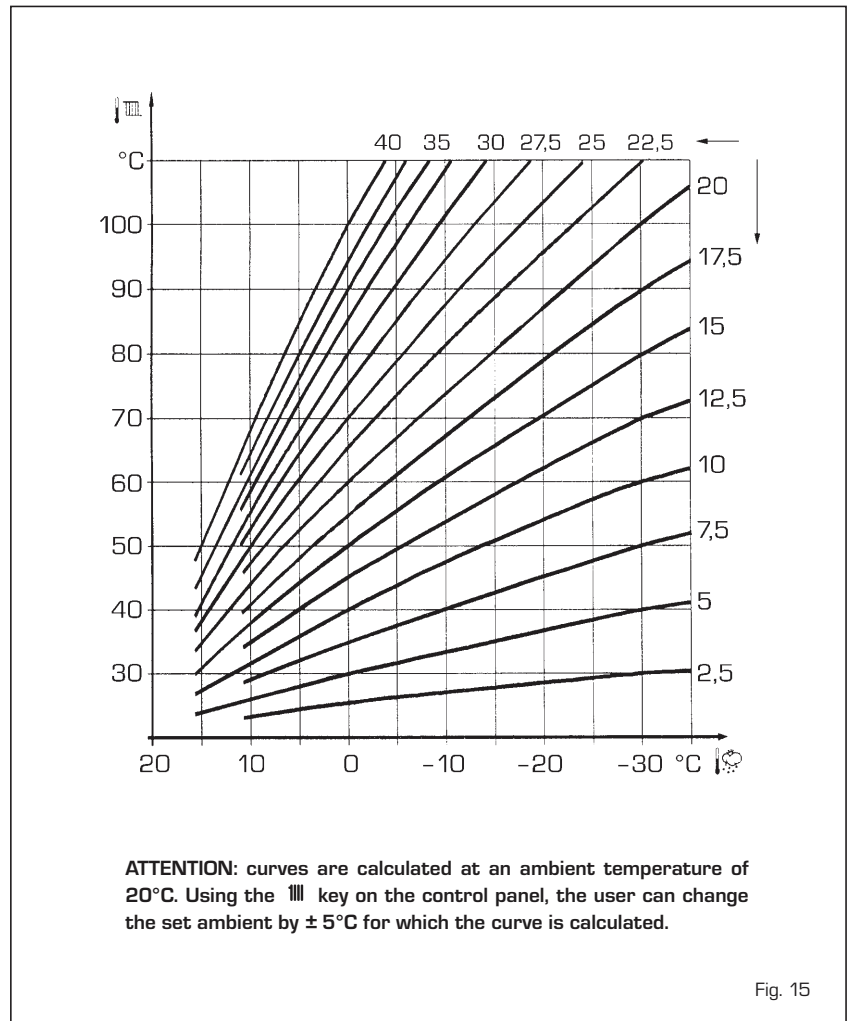

Fig. 15

3.7 ELECTRONIC IGNITION

Ignition and flame detection is controlled by a single electrode on the burner which guarantees reaction in the case of accidental extinction or lack of gas within one second.

It can be caused by an interruption in the electrode wire or if it is incorrectly anchored to the connection points. Or the electrode may be earthed or strongly worn: it must be replaced. Or the electronic card may be defective.

3.7.1 Functioning cycle

Burner ignition occurs within max. 10 seconds after the opening of the gas valve. Ignition failure with consequent activation of block can be due to:

- **Lack of gas**
The ignition electrode persists in discharging for max. 10 seconds. If the burner does not ignite, the anomaly is signalled. This can happen the first time the boiler is switched on after a long period of inactivity due to the presence of air in the gas pipes.
It can be caused by a closed gas tap or by a broken valve coil (the interruption does not allow for opening).
- **The electrode does not discharge.**
In the boiler, only the opening of the gas to the burner can be detected. After 10 seconds the anomaly is signalled.

In the case of a sudden lack of voltage, the burner will immediately switch off. When voltage returns, the boiler will automatically start up again.

3.8 FUMES PRESSURE SWITCH

The pressure switch is calibrated by the manufacturer at the following values: 0.62 - 0.72 H₂O which can guarantee boiler functioning also with aspiration and discharge pipes of the maximum length allowed. The value of the signal to the pressure switch is measured by a differential pressure gauge connected as indicated in fig. 16.

3.9 WATER PRESSURE VALVE

The water pressure valve (C fig. 17/a) intervenes, blocking burner functioning, if it detects that there is insufficient pressure in the boiler (< 0,9 bar).

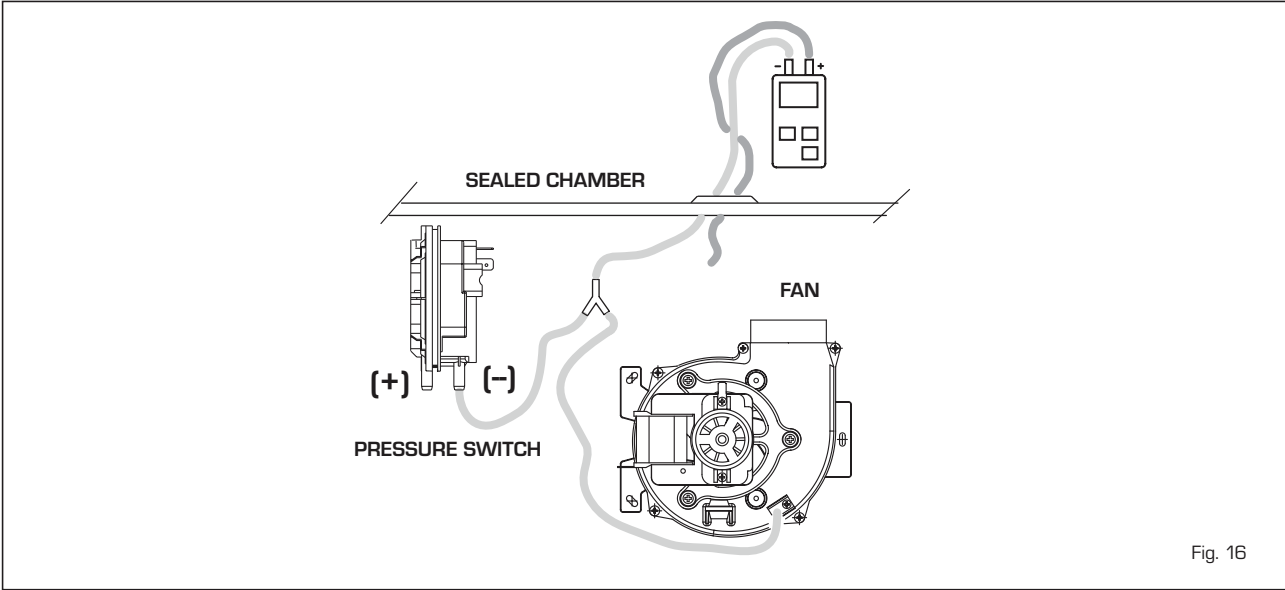

Fig. 16

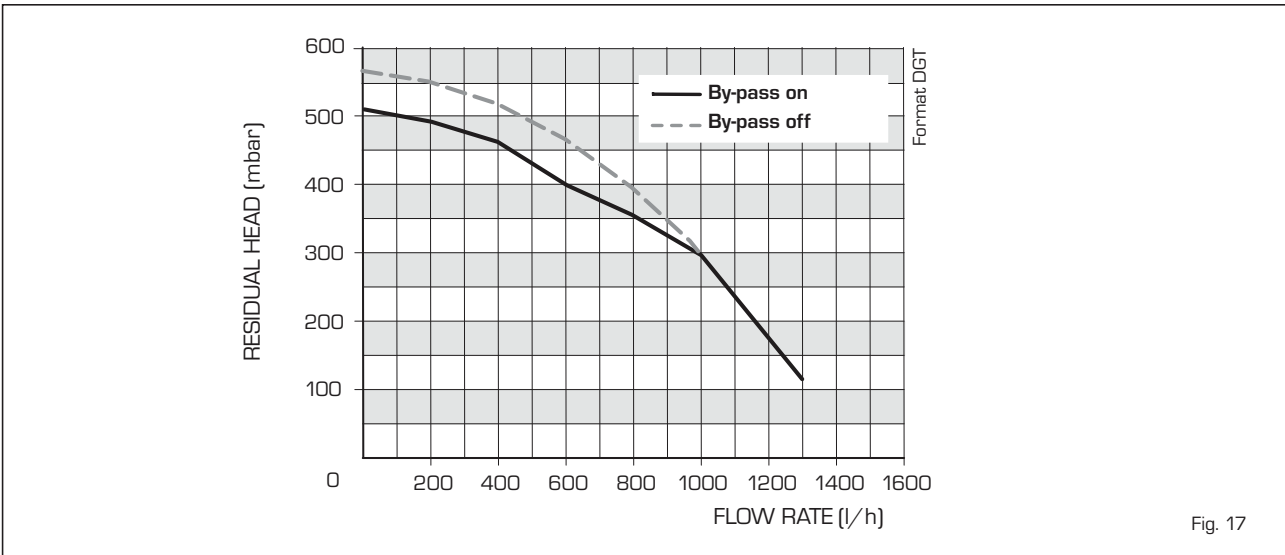

Fig. 17

To restore burner functioning, to bring back the pressure of the boiler at values comprise between 1 - 1,2 bar.

3.10 HEAD AVAILABLE TO SYSTEM

Residual head for the heating system is shown as a function of rate of flow in the graph in fig. 17.

To obtain the maximum head available to the system, turn off the by-pass by turning the union to the vertical position (fig. 17/a).

NOTE: The expansion vessel supplied with the boiler is suitable for heating systems with a maximum water capacity of 80 litres. In excess of such capacity, arrange for an additional expansion vessel.

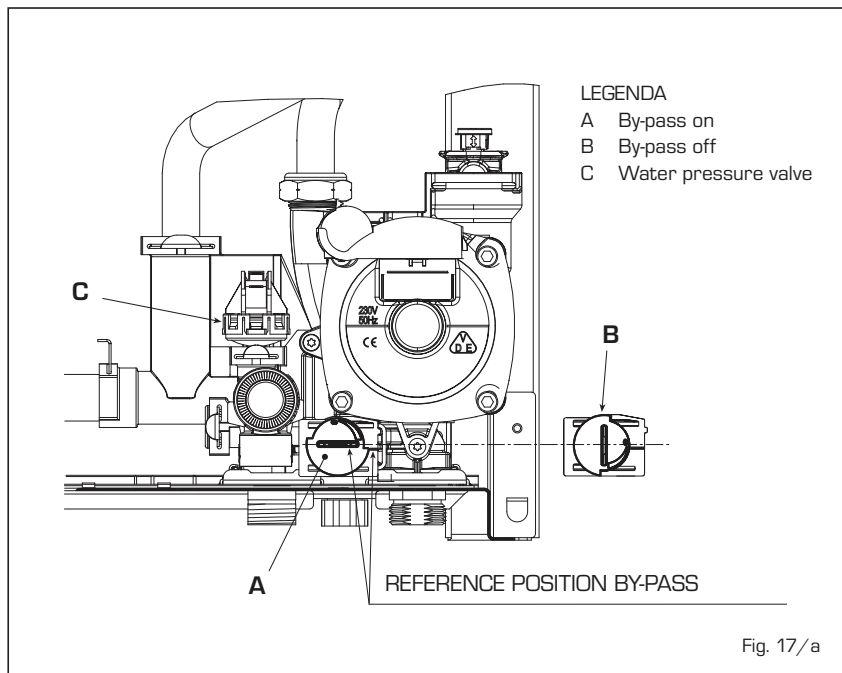

Fig. 17/a

4 USE AND MAINTENANCE

4.1 GAS VALVE

The boilers are equipped standard with the SIT 845 SIGMA gas valve (fig. 18).

The gas valve is set at two pressure values: maximum and minimum.

According to the type of gas burnt, these correspond to the values given in **Table 4**.

The gas pressures at the maximum and minimum values, are factory set. Consequently they must not be altered.

Only when you switch the appliance from one type of gas supply (methane) to another (butane or propane), it is permitted to alter the operating pressure.

4.2 GAS CONVERSION

This operation must be performed by authorised personnel using original Sime components.

To convert from natural gas to LPG or vice versa, perform the following operations (fig. 19):

- Close the gas cock.
- Disassemble the burner manifold (3).
- Replace the main nozzles (6) supplied in a kit, inserting the copper washer (4). Use a $\varnothing 7$ spanner to perform this operation.
- Configure the new fuel as indicated in point 4.2.1
- For calibrating the maximum and minimum gas pressure values, see point 4.2.2.
- After have ultimated the conversion of the boiler, please stick onto the casing panel the plate showing the relevant feeding gas which is included into the kit.

NOTE: When reassembling components which you have removed, replace gas seals; test all gas connections after assembly using soapy water or a product made specifically for the purpose, being sure not to use open flame.

4.2.1 New fuel configuration

Access the parameters section by pressing the control panel keys (and) at the same time for 5 seconds.

The red LED flashes and the display shows:



Scroll the parameters using or .

To enter the fuel configuration parameter PAR 01, use - or +.

The set value **flashes** and if the boiler in question is a methane, the display shows:

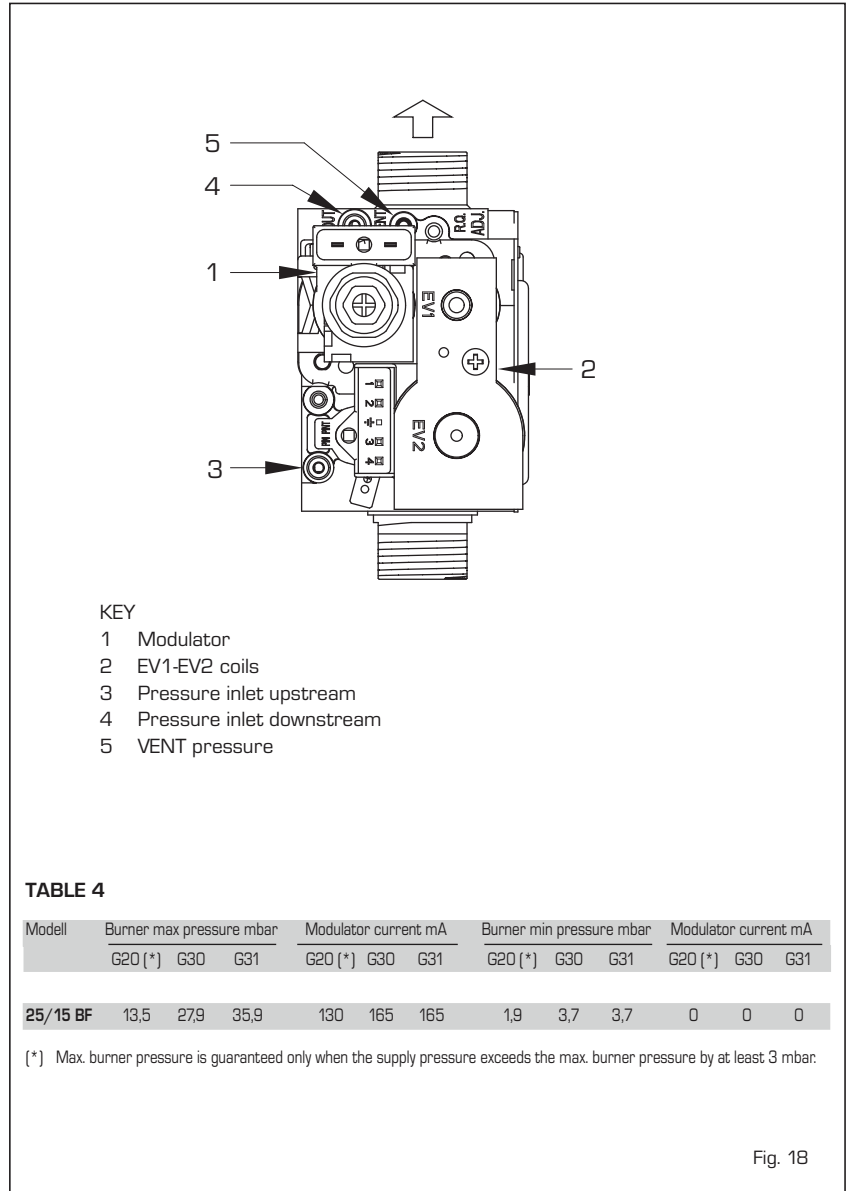

Fig. 18

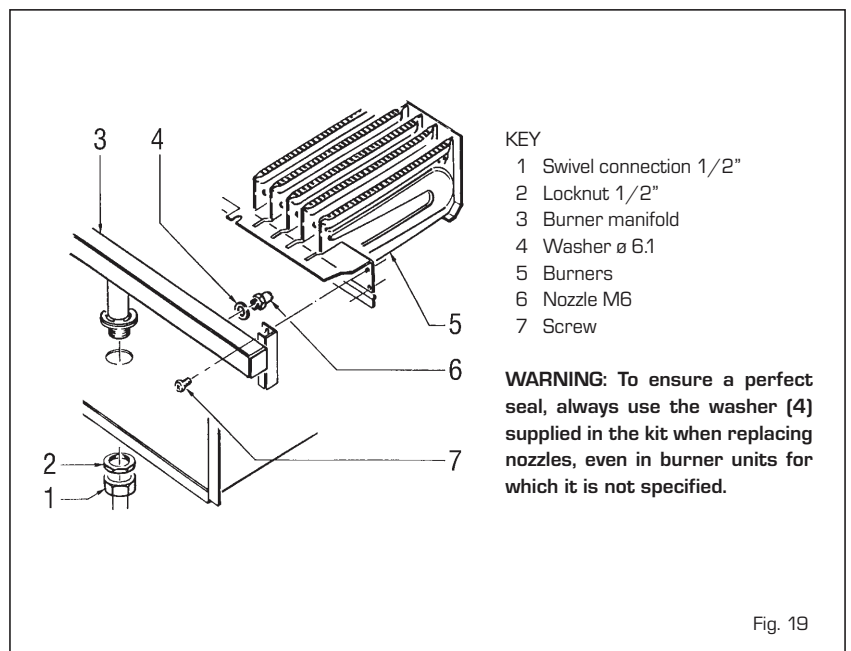

Fig. 19

For boiler to function with LPG, press **+** until **03** appears.
 Confirm this value using or .
 Exit the parameters section by pressing .

The table below gives the values to set when the supply gas is changed:

GAS	MODELS	PAR 1
METHANE	25/15 BF	01
	-	02
LPG	25/15 BF	03
	-	04
-	-	05
	-	06
	-	07
	-	08

4.2.2 Adjusting valve pressure

Set maximum and minimum pressure on gas valves as follows (fig. 20):

- Connect the column or a manometer to the intake downstream of the gas valve. **Disconnect the valve VENT pressure test point tube (5 fig. 18).**
- Remove the cap (1) from the modulator.
- Press the keys (**-** and **+**) at the same time for a few seconds and completely open the hot sanitary water faucet.
- Press the key **+** (Hi).
- Remember that rotating clockwise will increase pressure while rotating anti-clockwise will diminish it.
- Adjust maximum pressure using the nut (3) with a wrench to the maximum pressure value indicated in **Table 4.**
- Adjust the maximum pressure before adjusting the minimum.
- Press the key **-** (Lo) while the sanitary

- water tap is on, with the water running.
- Lock the nut (3) in place, turn the screw/nut (2) to the minimum pressure indicated in **Table 4.**
- Press the keys (**-** and **+**) while keeping the hot sanitary water running all the time, and check that the maximum and minimum pressures correspond to the set values; if necessary correct the regulation.
- Press the key again to quit the function.
- Put the pipe back on the valve VENT pressure test point.
- Remove the manometer, remembering to tighten the screw for closing the pressure test point.
- Put the plastic cap (1) back on the modulator and seal with a drop of coloured sealant if necessary.

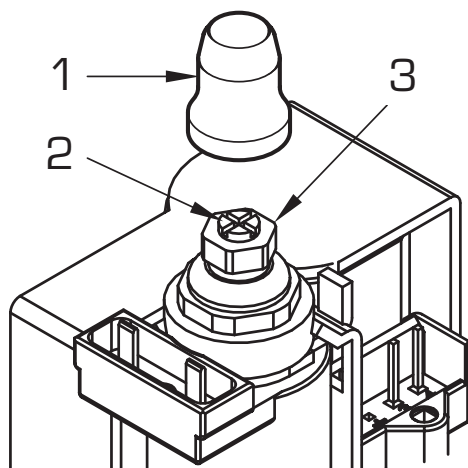

- KEY
- 1 Plastic tap
 - 2 Minimum pressure adjusting nut
 - 3 Maximum pressure adjusting nut

Fig. 20

4.3 DISASSEMBLING THE SHELL

The casing may be removed completely to facilitate boiler maintenance, as shown in fig. 21. Turn the panel control forward for access to the internal components of the boiler.

4.4 MAINTENANCE

To guarantee functioning and efficiency of the appliance, in respect of the legal provisions in force, it must be regularly checked; the frequency of the checks depends on the type of appliance and the installation and usage conditions.

In any case, it should be inspected at least once a year by a qualified technician.

Carry out the cleaning of the generator in

the following way:

- Turn the main switch off to stop electric power reaching the boiler and close the gas feed cock.
- Remove the outer casing and the gas burner manifold unit. To clean the burner, blow in a jet of air, so as to remove any dust particles that may have accumulated.
- Clean the heat exchanger, removing any dust or residue from combustion. When cleaning the heat exchanger or the burners, chemical products or steel brushes **MUST NOT BE USED**. Make sure that the tops of the burners with the holes are free from encrustations.
- Reassemble the items removed from the boiler, making sure to follow the correct sequence.
- Check operation of the main burner:

- After assembly of all the gas connections, these must be tested for soundness, using soapy water or appropriate products. **DO NOT USE NAKED FLAMES.**
- Do not use calcium chloride to treat the plastic component during generator maintenance.

4.4.1 Chimney sweep function

To check boiler combustion, press at the same time the installer's key (- e +) for a few seconds.

The chimney sweep function will switch on and will continue for 15 minutes.

During the 15 minutes functioning of chimney sweep function, pressing the keys (- and +) take the boiler respective at maximum (Hi) and at minimum (Lo) power:

From that moment, the boiler will start

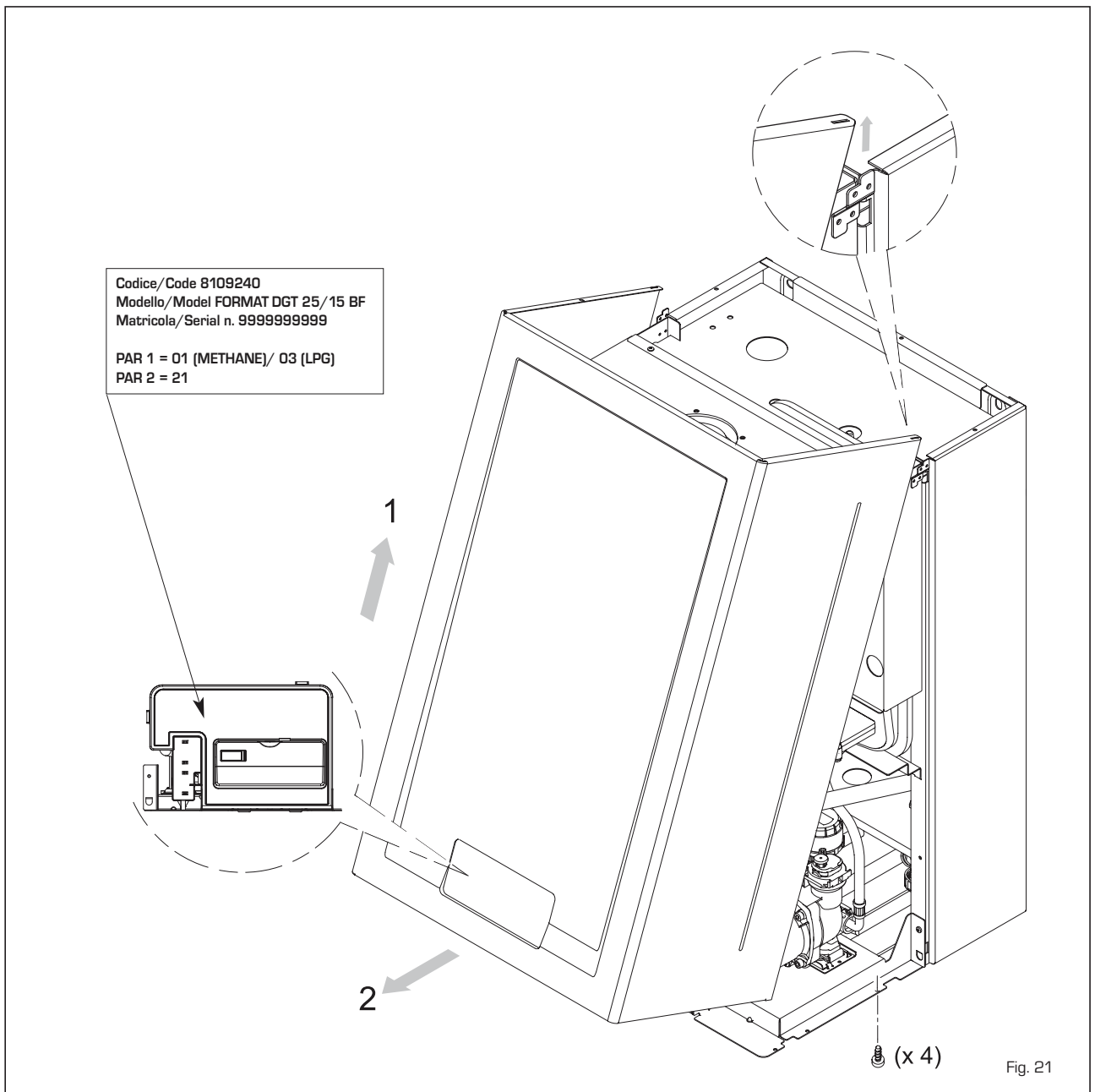

Fig. 21

working in heating mode at maximum power, with cut off at 80°C and re-ignition at 70°C.

Before activating the chimney sweep function make sure that the radiator valves or eventual zone valves are open.

The test can also be carried out with the boiler working in D.H.W. mode.

For this, after activating the chimney sweep function, open one or more hot water faucets.

Under these conditions, the boiler will function at maximum power with the D.H.W. kept at between 60°C and 50°C.

During the test, the hot water faucets must remain open.

For exit to the chimney sweep function press the key of the control panel.

The chimney sweep function will automatically switch off after 15 minutes from the activation.

4.5 FUNCTIONING ANOMALIES

When there is a functioning anomaly, an alarm appears on the display **and switch on the red led.**

Descriptions of the anomalies with relative alarms and solutions are given below:

- FUMES DISCHARGE ANOMALY "ALARM 01"

The fumes thermostat has intervened. If the condition causing the problem persists for two minutes, the boiler stops for an enforced period of thirty minutes.

At the end of this period, the boiler re-attempts ignition.

- LOW WATER PRESSURE ANOMALY "ALARM 02" (fig. 24/a)

If the pressure detected by the water pressure valve is lower than 0.5 bar, the boiler stops and the display shows the alarm "AL 02".

Bring the pressure back to normal by means by acting on the telescopic loading knob.

Lower the knob and turn it anti-clockwise to open until the pressure indicated on the hydrometer reaches 1 - 1.2 bar.

WHEN FILLING HAS BEEN COMPLETED, CLOSE THE KNOB BY TURNING IT CLOCKWISE.

If the load procedure has to be repeated several times, it is advisable to check that the seal of the heating circuit is intact (check that there are no leaks).

- HEATING SENSOR ANOMALY "ALARM 05"

If one or both sensing elements of heating sensor (SM1/SM2) are open or short circuited, the boiler will not function and the display will show the alarm "AL 05".

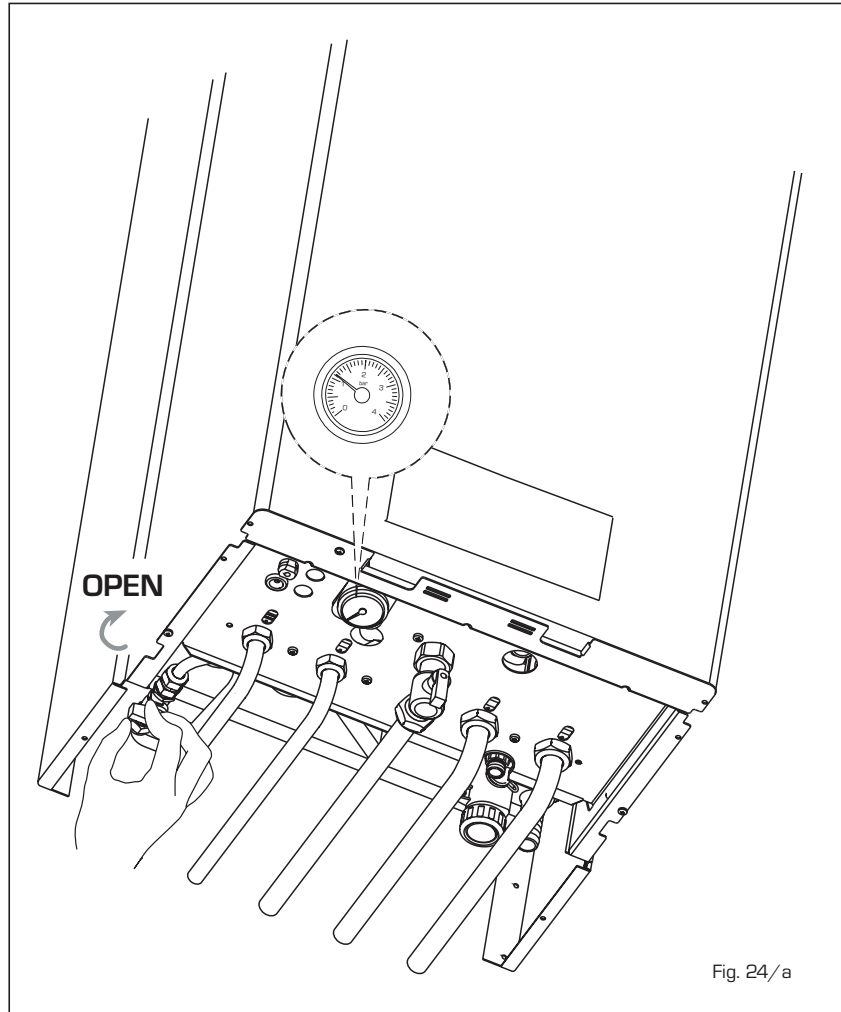

Fig. 24/a

- FLAME BLOCK "ALARM 06" (fig. 24/b)

If the flame control has not detected the presence of the flame after a complete ignition sequence, or for any other reason the card cannot "see" the flame, the boiler will stop and the display will show the alarm "AL 06".

Press the key of the controls to start up the boiler again.

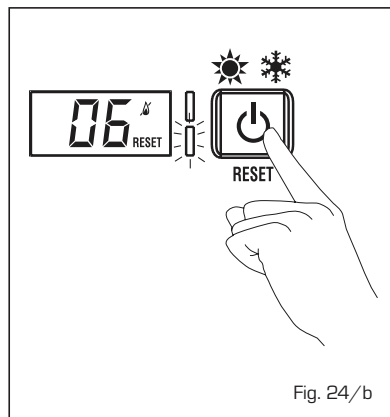

Fig. 24/b

- SAFETY THERMOSTAT ANOMALY "ALARM 07" (fig. 24/c)

If the C.H. sensor (SM1/SM2) exceeds the 100°C the boiler does not ignite the burner, the display show AL 07 and

remains ignited the green led. If this condition restored more one minute, the boiler will stop, the display show always the anomaly AL 07 and switch on the red led.

Press the key of the controls to start up the boiler again.

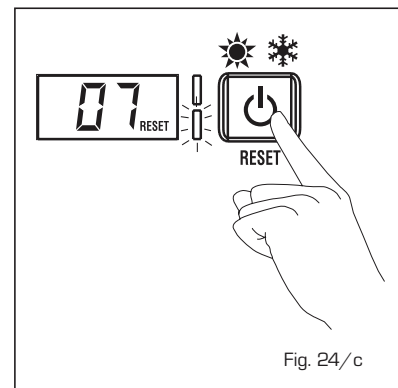

Fig. 24/c

- PARASITE FLAME ANOMALY "ALARM 08"

If the flame control section recognises the presence of flames also in phases when they should not be present, it means there is a breakdown in the flame detection circuit; the boiler will stop and the display will show anomaly "AL 08".

- **AUXILIARY SENSOR ANOMALY "ALARM 10"**

ONLY FOR BOILER WITH SOLAR PLANT COUPLING (PAR 2 = 10 or 14);

D.H.W. inlet probe anomaly. When the probe is open or short circuited the boiler loses the solar function and the display shows anomaly AL 10.

does not function and the display shows anomaly AL 17.

Replace the heating probe (SM1/SM2) to restore functioning.

- **MODULATOR ANOMALY "ALARM 11"**

The modulator is not connected.

When during functioning the boiler detects zero current to the modulator, the display will show anomaly "AL 11".

The boiler will function at minimum power and the anomaly will be de-activated when the modulator is reconnected or when the burner stops working.

- **CONFIGURATION ANOMALY "ALARM 12"**

Anomaly in the SEALED/OPEN configuration. There may be a conflict between the values set by the installer for PAR 1 and the self-detection carried out by the card causes the activation of the alarm: the boiler will not function and the display will show anomaly "AL 12".

Reset PAR 1 to de-activate the alarm or check the pressure switch/combustion product thermostat and relative connection.

- **HEATING PROBE POSITIONING ANOMALY SM1/SM2 "ALARM 16"** (fig. 24/d)

If the probe does not detect a temperature increase after burner ignition, the burner switches off after 10 seconds, the display shows anomaly AL 16 and the 4 green LED stays on.

If the anomaly occurs three times within 24h the boiler blocks, the display continues to show anomaly AL 16 and the red LED switches on.

Press  on the control panel to restart the boiler.

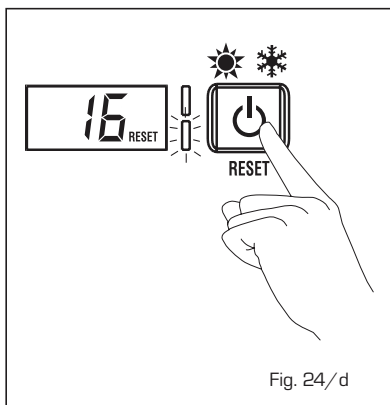

Fig. 24/d

- **SENSOR ALIGNMENT ANOMALY "ALARM 17"**

When the two sensitive elements of the heating probe (SM1/SM2) differ to each other by more than 16°C the boiler

USER INSTRUCTIONS

ES

PT

ENG

WARNINGS

- In case of fault and/or incorrect equipment operation, deactivate it, without making any repairs or taking any direct action. Apply only to qualified technical personnel.
- Boiler installation and any other assistance and/or maintenance activity must be carried out by qualified personnel pursuant to Standard CEI 64-8. Under no circumstances, the devices sealed by the manufacturer can be tampered with.
- It is absolutely prohibited to block the intake grilles and the aeration opening of the room where the equipment is installed.
- The manufacturer shall not be held liable for any damage caused by improper use of the appliance.
- This appliance is not intended for use by persons (including children) with reduced physical, sensory or mental capabilities, or lack of experience and knowledge, unless they have been given supervision or instruction concerning use of the appliance by a person responsible for their safety. Children should be supervised to ensure that they do not play with the appliance.

LIGHTING AND OPERATION

KEYS LOCK: if the device is not used, the keys will be locked 15 minutes after the last setting was made (PAR 5 by default) and the display light switches off.

To set one of the operating modes, press any of the keys for more than two seconds (the display will indicate one to four segments progressively before unlocking the controls).

BOILER IGNITION (fig. 25)

The first ignition of the boiler must be carried out by qualified technical personnel.

Successively, if it is necessary to start up the boiler again, adhere strictly to the following instructions: open the gas tap to allow the flow of the fuel and move the main switch of the system to "ON".

After a stop, wait for about 30 seconds before restoring functioning conditions so that the boiler can perform the control sequence.

If the green led is on, this indicates the presence of voltage.

Winter

Press the key  of the controls to activate the winter mode functioning (heating and D.H.W.). The display will be as shown in the figure.



Summer

Press the key  of the controls to activate the summer mode functioning (only the production D.H.W.). The display will be as shown in the figure.

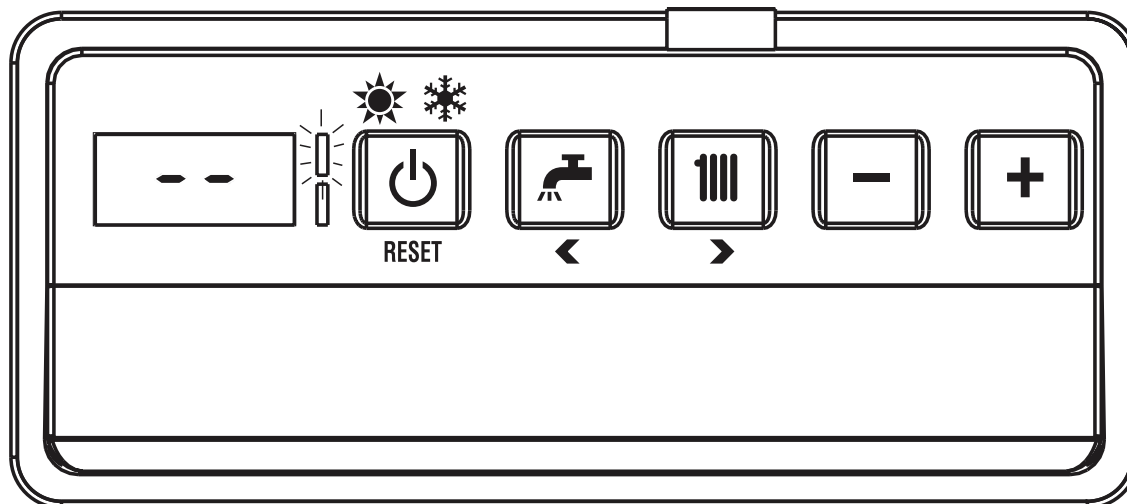

ATTENTION: for set up modality of function more adapted to graze the keys simply. One beep indicates that the boiler has taken command. If PAR 5 is disabled, the display remains lit.

Fig. 25

REGULATION OF THE WATER TEMPERATURE FOR HEATING (fig. 26)

To set the temperature of the water for heating, press the key of the controls . The display will be as shown in the figure. Change the values with the key [- and +]. Standard visualisation will return to the display by pressing the key again, or after 10 seconds if no key is pressed.

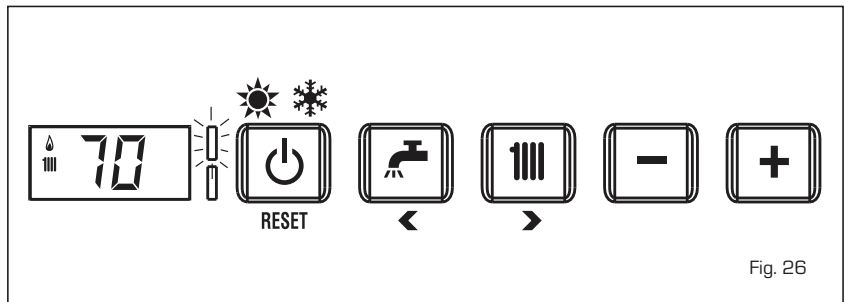

Fig. 26

Regulation of the external sensor

If an external sensor is installed, the value of the output temperature is automatically chosen by the system, which quickly adjusts the of flow temperature on the basis of the external temperature.

If you wish to change the value of the temperature, increasing or decreasing that calculated automatically by the electronic card, proceed as indicated in the preceding paragraph.

The level of various correction of a value of temperature proportional calculated. The display will be as shown in fig. 26/a.

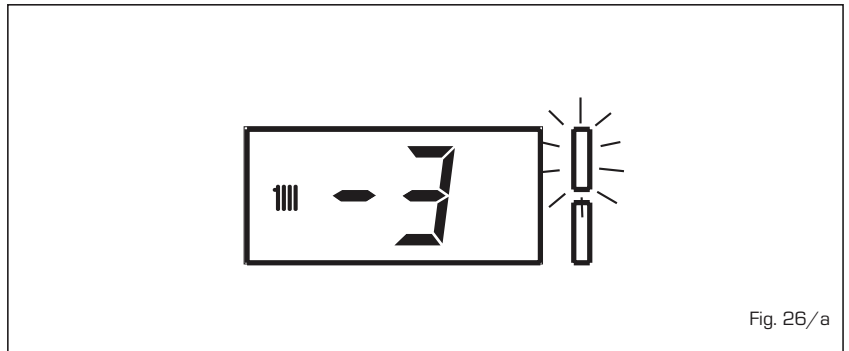

Fig. 26/a

REGULATION OF THE D.H.W. TEMPERATURE (fig. 27)

To set the desired temperature D.H.W., press the key of the controls. The display will be as shown in figure. Change the values with the key [- and +]. The display will return to the standard visualisation by pressing the key again, or after 10 seconds if no key is pressed.

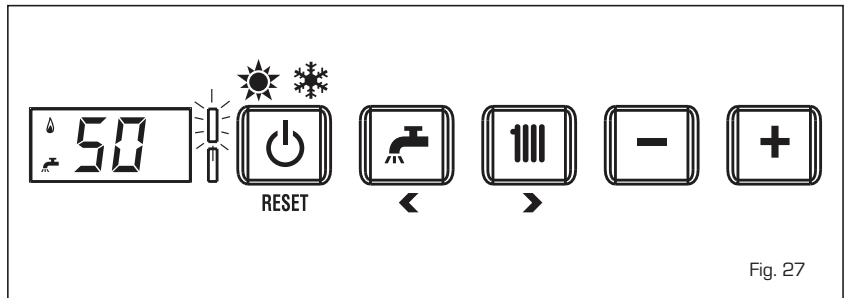

Fig. 27

TO SWITCH OFF THE BOILER (fig. 28)

In the case of a short absence, press more than two second the key of the controls. The display will be as shown in figure (boiler in stand-by). In this way, leaving the electricity and the fuel supply connected, the boiler is protected from frost and from the pump becoming blocked.

If the boiler is not used for a prolonged period, it is advisable to disconnect the electricity supply, by switching off the main switch of the system, and to close the gas tap and, if low temperatures are expected, to completely empty the hydraulic circuits to avoid pipes being broken by the formation of ice in the pipes.

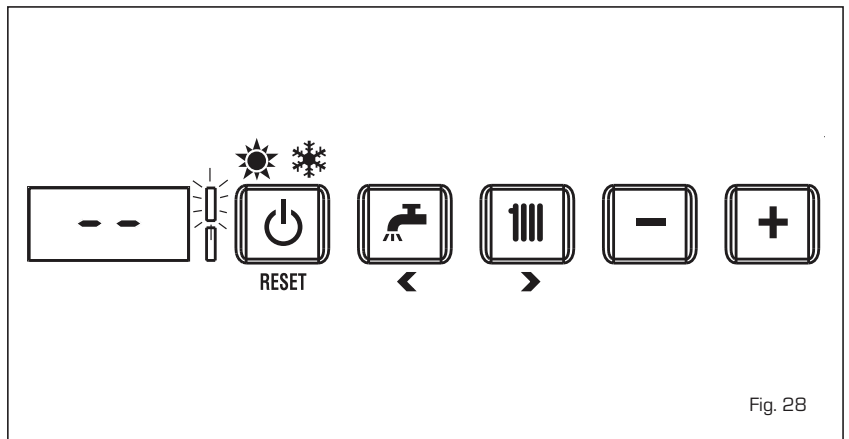

Fig. 28

ANOMALIES AND SOLUTIONS

When there is a functioning anomaly, the display controls shows **and red led switch on**.

Descriptions of the anomalies with the relative alarms and solutions are given below:

- **AL 01**

Press the key of the controls to re-start the boiler.

If the anomaly persists, request the intervention of qualified technical personnel.

- **AL 02** (fig. 29/a)

If the water pressure detected is lower than 0.5 bar, the boiler will stop and the display will show "AL 02". Bring the pressure back to normal by specific valve until the pressure indicated by the hydrometer is between **1 and 1.2 bars**.

ONCE IT HAS BEEN FILLED, CLOSE THE LOADING VALVE.

If it is necessary to repeat the system loading procedure, it is advisable to contact qualified technical personnel to check the seal of the heating system (to check whether there are any leaks).

- **AL 05**

Request assistance from qualified technical personnel.

- **AL 06** (fig. 29/b)

Press the key of the controls to re-start the boiler.

If the anomaly persists, request assistance from qualified technical personnel.

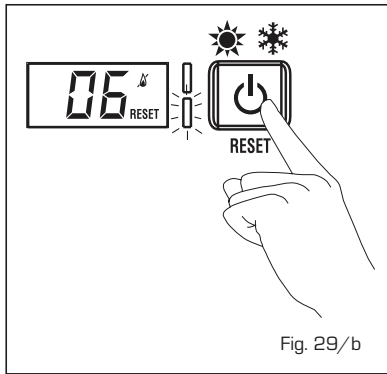

Fig. 29/b

- **AL 07** (fig. 29/c)

Press the key of the controls to re-

start the boiler.

If the anomaly persists, request assistance from qualified technical personnel.

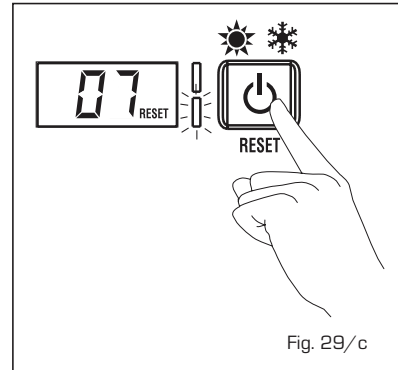

Fig. 29/c

- **AL 08/AL 10/AL 11/AL 12**

Request assistance from qualified technical personnel.

- **AL 16** (fig. 29/d)

Press the key of the controls to re-start the boiler.

If the anomaly persists, request assistance from qualified technical personnel.

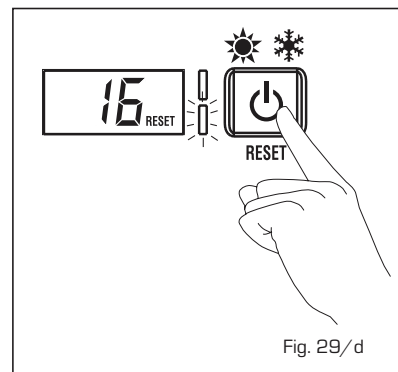

Fig. 29/d

- **AL 17**

Request assistance from qualified technical personnel.

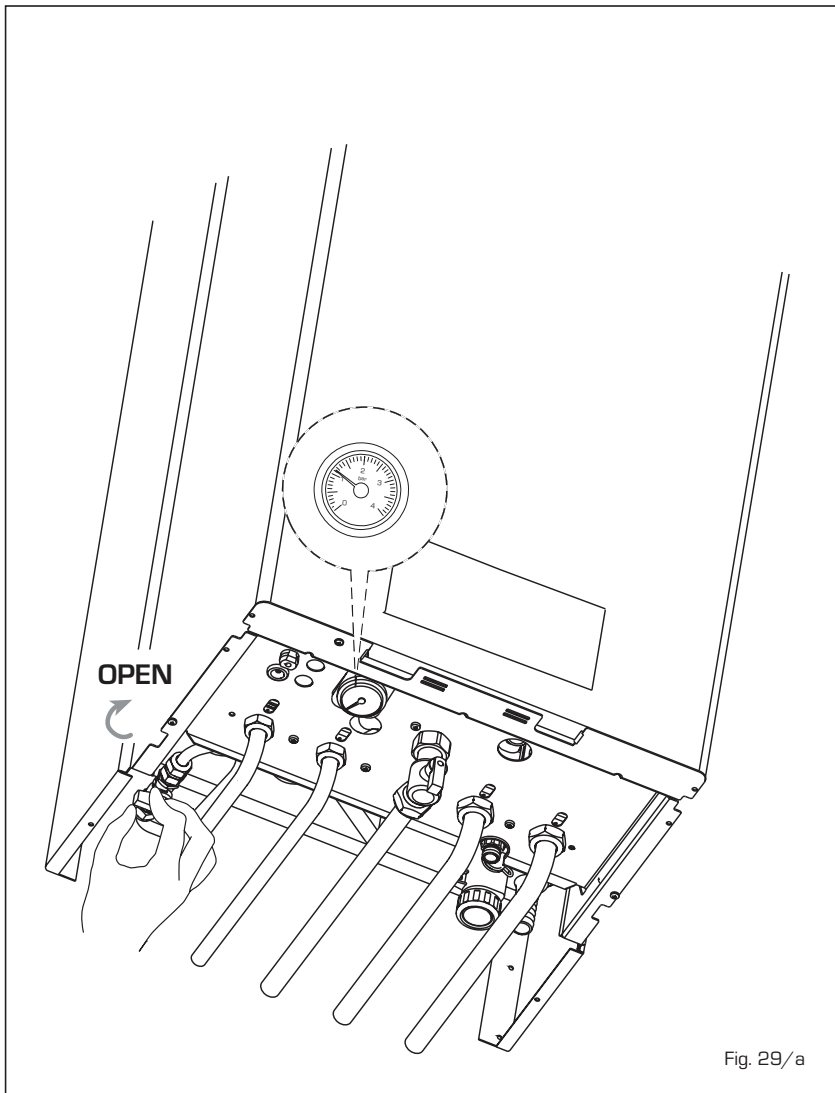

Fig. 29/a

GAS CONVERSION

If it is necessary to change to a different type of gas, request assistance only from authorised technical personnel.

MAINTENANCE

Annual maintenance of the appliance should be planned sufficiently in advance, requesting the assistance of authorised technical personnel.

The boiler is supplied with an electric wire for the electrical power supply which, in the case of replacement, must be substituted only by another obtained from the constructor.

NOTE



Fonderie Sime S.p.A - Via Garbo, 27 - 37045 Legnago (Vr)
Tel. + 39 0442 631111 - Fax +39 0442 631292 - www.sime.it