

**17. FLOOR STANDING TYPE
(CONSOLE TYPE)
PACKAGED AIR-CONDITIONER
(Split system, Air to air)
heat pump type**

**FDFL258HEN-SA
308HEN-SA
308HES-SA**

CONTENTS

- 17.1 GENERAL INFORMATION 657**
 - 17.1.1 Specific features 657**
 - 17.1.2 How to read the model name 657**
- 17.2 SELECTION DATA 658**
 - 17.2.1 Specifications 658**
 - 17.2.2 Range of usage & limitations 661**
 - 17.2.3 Exterior dimensions 662**
 - 17.2.4 Exterior appearance 664**
 - 17.2.5 Piping system 665**
 - 17.2.6 Selection chart 667**
 - 17.2.7 Noise level 669**
- 17.3 ELECTRICAL DATA 670**
 - 17.3.1 Electrical wiring 670**
- 17.4 OUTLINE OF OPERATION CONTROL BY MICROCOMPUTER 673**
- 17.5 APPLICATION DATA 673**
 - 17.5.1 Installation of indoor unit 674**
 - 17.5.2 Installation of outdoor unit 676**
- 17.6 MAINTENANCE DATA 676**

17.1 GENERAL INFORMATION

17.1.1 Specific features

- (1) Less refrigerant charge amount due to use of double phase refrigerant flow system. The total refrigerant charge amount has been reduced by more than 50%.
- (2) The indoor outdoor interconnection signal wiring has been done away with. The microcomputer chip is installed in the indoor unit. There is no need for the unit to communicate between the outdoor and indoor units so the unit is more resistant to electromagnetic noise thus the incidence of microcomputer malfunction has been reduced. The compressor in the outdoor unit has its own self protection function, that reacts according to abnomal high pressure and excessive high temperature.
- (3) There are only five power lines between the outdoor and indoor unit. As no signal wire is used there is no need to separate the power line from the signal line. One cab type cable with 6 wires encased in one sheath is enough for conducting the wiring work between the outdoor unit and the indoor unit. This contributes to simpler wiring work in the field.
- (4) All models have service valves protruding from the outdoor unit for faster flare connection work in the field.
- (5) **Simple design**

The unit has a thickness that masures a mere 7.24 inches, making it the thinnest floor standing air-conditioning unit in its class.

- (6) **Self-diagnosing function**

If any of troubles, such as an abnormality with the power supply and disconnection in the thermistor circuit, has occured, such abnormality, etc. are indicated by a blinking signal, displaying the trouble mode in letters on the liquid crystal display of the remote controller. It is also possile to monitor any such abnormality with a checking switch. When plural units are controlled. No. of the unit in trouble is also indicated.

17.1.2 How to read the model name

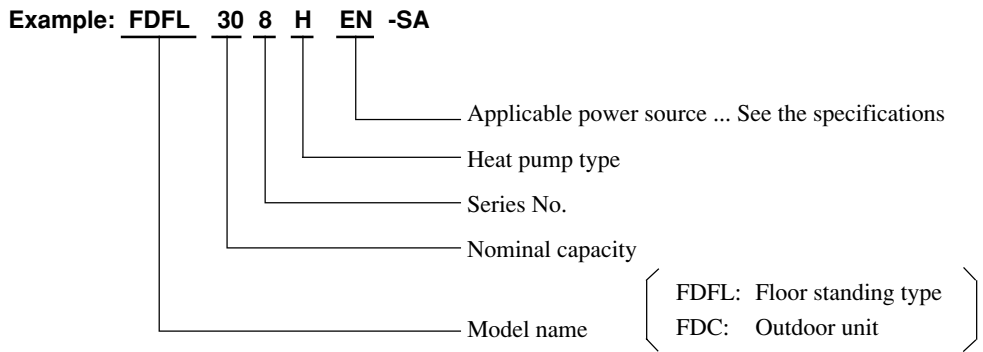

17.2 SELECTION DATA

17.2.1 Specifications

Model FDFL258HEN-SA

Item	Model	FDFL258HEN-SA	
		FDFL258-A	FDC258HEN3A
Nominal cooling capacity ⁽¹⁾	W	5700	
Nominal heating capacity ⁽¹⁾	W	6100	
Power source		1 Phase, 220/240V, 50Hz	
Operation data ⁽³⁾	Cooling input	kW	2.04/2.15
	Running current (Cooling)	A	9.4/9.4
	Power factor (Cooling)	%	99/95
	Heating input	kW	1.94/2.09
	Running current (Heating)	A	9.1/9.2
	Power factor (Heating)	%	97/95
	Inrush current	A	51
	Noise level	dB(A)	Hi: 44 Lo: 39
Exterior dimensions Height × Width × Depth	mm	(650 + 50) × 1260 × 184	
Net weight	kg	33	55
Refrigerant equipment Compressor type & Q'ty		–	RM5526GNE4 × 1
Motor	kW	–	1.9
Starting method		–	Line starting
Heat exchanger		Louver fins & inner grooved tubing	Slitted fins & bare tubing
Refrigerant control		Capillary tube	
Refrigerant		R22	
Quantity	kg	Holding charged	1.1 [Pre-charged up to the piping length of 5m]
Refrigerant oil	ℓ	–	0.7 [BARREL FREEZE32SAM]
Defrost control		MC controlled de-icer	
High pressure control		High pressure switch	
Air handling equipment Fan type & Q'ty		Multiblade centrifugal fan × 4	Propeller fan × 1
Motor	W	25 × 2	55 × 1
Starting method		Line starting	Line starting
Air flow (Standard)	CMM	Hi: 16 Lo: 10.5	56
Fresh air intake		Not possible	
Air filter, Q'ty		Polypropylene net × 2 (Washable)	
Shock & vibration absorber		Rubber sleeve (for fan motor)	Rubber mount (for compressor)
Electric heater	W	–	20 (Crank case heater)
Operation control Operation switch		Wired remote control switch (Optional : RCD-H-E)	– (Indoor unit side)
Room temperature control		Thermostat by electronics	–
Safety equipment		Internal thermostat for fan motor. Frost protection thermostat.	Internal thermostat for fan motor. Abnormal discharge temperature protection.
Installation data Refrigerant piping size	mm (in)	Liquid line: φ9.52 (3/8") Gas line: φ15.88 (5/8")	
Connecting method		Flare piping	
Drain hose		(Connectable with VP20)	–
Insulation for piping		Necessary (both Liquid & Gas lines)	
Accessories		Mounting kit.	
Optional parts		–	

Notes (1) The data are measured at the following conditions.

Operation	Item	Indoor air temperature		Outdoor air temperature		Standards
		DB	WB	DB	WB	
Cooling		27°C	19°C	35°C	24°C	ISO-T1, JIS B8616
Heating		20°C	–	7°C	6°C	

(2) This packaged air-conditioner is manufactured and tested in conformity with the following standard.

JIS B8616 "UNITARY AIR-CONDITIONERS"

(3) The operation data indicate when the air-conditioner is operated at 220/240V 50Hz.

Model FDFL308HEN-SA

Item		Model	FDFL308HEN-SA	
			FDFL308-A	FDC308HEN3
Nominal cooling capacity⁽¹⁾		W	7100	
Nominal heating capacity⁽¹⁾		W	8000	
Power source			1 Phase, 220/240V, 50Hz	
Operation data⁽³⁾	Cooling input	kW	2.99/3.19	
	Running current (Cooling)	A	13.9/14.4	
	Power factor (Cooling)	%	98/92	
	Heating input	kW	2.85/3.01	
	Running current (Heating)	A	13.3/13.7	
	Power factor (Heating)	%	97/92	
	Inrush current	A	95	
	Noise level	dB(A)	Hi: 45 Lo: 39	52
Exterior dimensions Height × Width × Depth		mm	(650 + 50) × 1260 × 184	
Net weight		kg	33	
Refrigerant equipment Compressor type & Q'ty			GT-A5534EN41 × 1	
Motor	kW	-		2.5
Starting method			Line starting	
Heat exchanger			Louver fines & inner grooved tubing	Slitted fins & bare tubing
Refrigerant control			Capillary tube	
Refrigerant			R22	
Quantity	kg	Holding charged	1.4 [Pre-charged up to the piping length of 5m]	
Refrigerant oil	ℓ	-	1.45 [BARREL FREEZE32SAM]	
Defrost control			MC controlled de-icer	
High pressure control			High pressure switch	
Air handling equipment Fan type & Q'ty			Multiblade centrifugal fan × 4	Propeller fan × 1
Motor	W	35 × 2		55 × 1
Starting method			Line starting	
Air flow (Standard)		CMM	Hi: 16.5 Lo: 11.5	58
Fresh air intake			Not possible	
Air filter, Q'ty			Polypropylene net × 2 (Washable)	
Shock & vibration absorber			Rubber sleeve (for fan motor)	Rubber mount (for compressor)
Electric heater	W	-		40 (Crank case heater)
Operation control			Wired remote control switch (Optional : RCD-H-E)	- (Indoor unit side)
Operation switch			-	
Room temperature control			Thermostat by electronics	
Safety equipment			Internal thermostat for fan motor. Frost protection thermostat.	Internal thermostat for fan motor. Abnormal discharge temperature protection.
Installation data			Liquid line: φ9.52 (3/8") Gas line: φ15.88 (5/8")	
Refrigerant piping size		mm (in)		
Connecting method			Flare piping	
Drain hose			(Connectable with VP20)	-
Insulation for piping			Necessary (both Liquid & Gas lines)	
Accessories			Mounting kit.	
Optional parts			-	

Notes (1) The data are measured at the following conditions.

Operation	Item	Indoor air temperature		Outdoor air temperature		Standards
		DB	WB	DB	WB	
Cooling		27°C	19°C	35°C	24°C	ISO-T1, JIS B8616
Heating		20°C	-	7°C	6°C	

- (2) This packaged air-conditioner is manufactured and tested in conformity with the following standard.
JIS B8616 "UNITARY AIR-CONDITIONERS"
- (3) The operation data indicate when the air-conditioner is operated at 220/240V 50Hz.

Model FDFL308HES-SA

Item		Model	FDFL308HES-SA	
			FDFL308-A	FDC308HES3
Nominal cooling capacity⁽¹⁾		W	7100	
Nominal heating capacity⁽¹⁾		W	8000	
Power source			3 Phase, 380/415V, 50Hz	
Operation data⁽³⁾	Cooling input	kW	2.91/2.97	
	Running current (Cooling)	A	5.1/5.5	
	Power factor (Cooling)	%	87/75	
	Heating input	kW	2.55/2.61	
	Running current (Heating)	A	4.6/4.8	
	Power factor (Heating)	%	84/76	
	Inrush current	A	45	
	Noise level	dB(A)	Hi: 45	Lo: 39
Exterior dimensions Height × Width × Depth		mm	(650 + 50) × 1260 × 184	
Net weight		kg	33	74
Refrigerant equipment Compressor type & Q'ty			-	GT-A5534ES41 × 1
Motor		kW	-	2.5
Starting method			-	Line starting
Heat exchanger			Louver fines & inner grooved tubing	Slitted fins & bare tubing
Refrigerant control			Capillary tube	
Refrigerant			R22	
Quantity		kg	Holding charged	1.4 [Pre-charged up to the piping length of 5m]
Refrigerant oil		ℓ	-	1.45 [BARREL FREEZE32SAM]
Defrost control			MC controlled de-icer	
High pressure control			High pressure switch	
Air handling equipment Fan type & Q'ty			Multiblade centrifugal fan × 4	Propeller fan × 1
Motor		W	35 × 2	55 × 1
Starting method			Line starting	Line starting
Air flow (Standard)		CMM	Hi: 16.5	Lo: 11.5
Fresh air intake			Not possible	
Air filter, Q'ty			Polypropylene net × 2 (Washable)	
Shock & vibration absorber			Rubber sleeve (for fan motor)	Rubber mount (for compressor)
Electric heater		W	-	40 (Crank case heater)
Operation control Operation switch			Wired remote control switch (Optional : RCD-H-E)	- (Indoor unit side)
Room temperature control			Thermostat by electronics	
Safety equipment			Internal thermostat for fan motor. Frost protection thermostat.	Internal thermostat for fan motor. Abnormal discharge temperature protection.
Installation data Refrigerant piping size		mm (in)	Liquid line: φ9.52 (3/8") Gas line: φ15.88 (5/8")	
Connecting method			Flare piping	
Drain hose			(Connectable with VP20)	-
Insulation for piping			Necessary (both Liquid & Gas lines)	
Accessories			Mounting kit.	
Optional parts			-	

Notes (1) The data are measured at the following conditions.

Item	Indoor air temperature		Outdoor air temperature		Standards
	DB	WB	DB	WB	
Operation					
Cooling	27°C	19°C	35°C	24°C	ISO-T1, JIS B8616
Heating	20°C	-	7°C	6°C	

- (2) This packaged air-conditioner is manufactured and tested in conformity with the following standard.
JIS B8616 "UNITARY AIR-CONDITIONERS"
- (3) The operation data indicate when the air-conditioner is operated at 380/415V 50Hz.

17.2.2 Range of usage & limitations

Item	Models	FDFL258 type	FDFL308 type
Indoor return air temperature (Upper, lower limits)		Refer to the selection chart	
Outdoor air temperature (Upper, lower limits)			
Refrigerant line (one way) length		Max. 30m	Max. 50m
Vertical height difference between outdoor unit and indoor unit		Max. 20m (Outdoor unit is higher) Max. 15m (Outdoor unit is lower)	Max. 30m (Outdoor unit is higher) Max. 15m (Outdoor unit is lower)
Power source voltage		Rating \pm 10%	
Voltage at starting		Min. 85% of rating	
Frequency of ON-OFF cycle		Max. 10 times/h	
ON and OFF interval		Max. 3 minutes	

17.2.3 Exterior dimensions

(1) Indoor unit

Models FDFL258-A, 308-A

Unit: mm

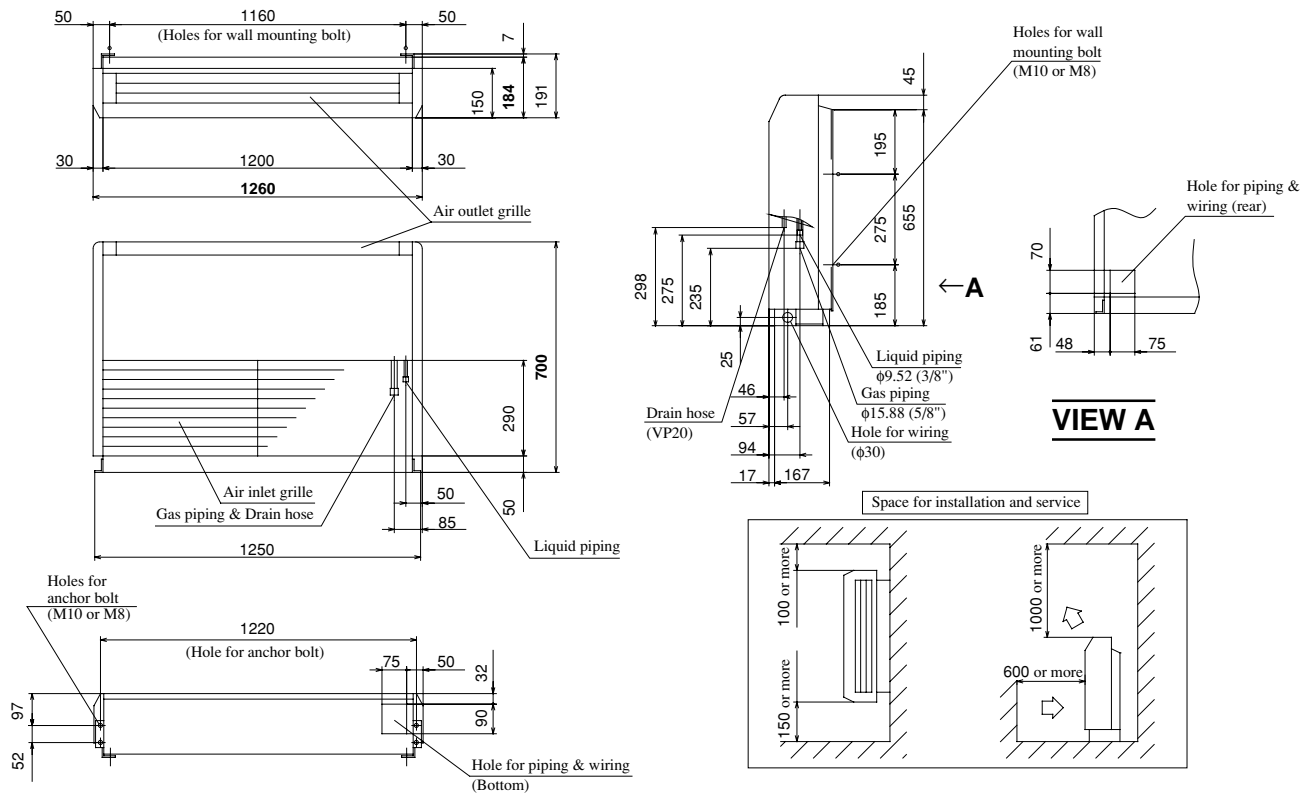

(2) Remote controller (Optional parts)

Unit: mm

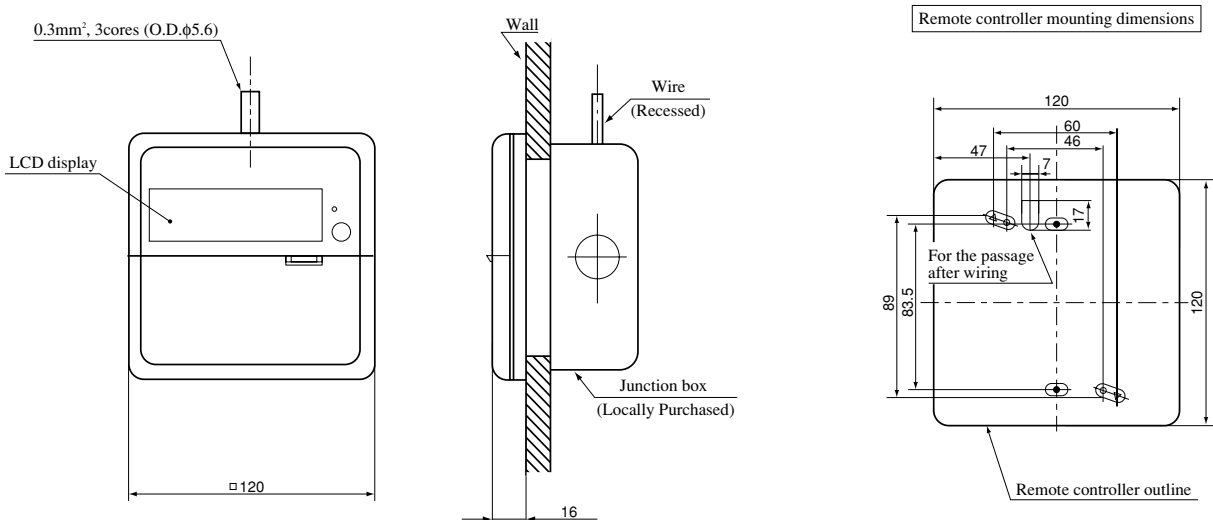

- ◆ Usable JIS box, JIS C 8336
 - Switch box for 1 piece (without cover)
(use of the ● mark hole as illustrated on the left)
 - Switch box for 2 pieces
(use of the ○ mark hole as illustrated on the left)
(without cover)
(use of the △ mark hole as illustrated on the left)
(when installing the cover)

Note (1) Allowable length of remote controller cable: 600 m

Allowable rang of wire thickness and length

Standard Within	0.3 mm ² × Within 100 m
	0.5 mm ² × Within 200 m
	0.75 mm ² × Within 300 m
	1.25 mm ² × Within 400 m
	2 mm ² × Within 600 m

(2) Outdoor unit

Models FDC258HEN3A, 308HEN3, 308HES3

Unit: mm

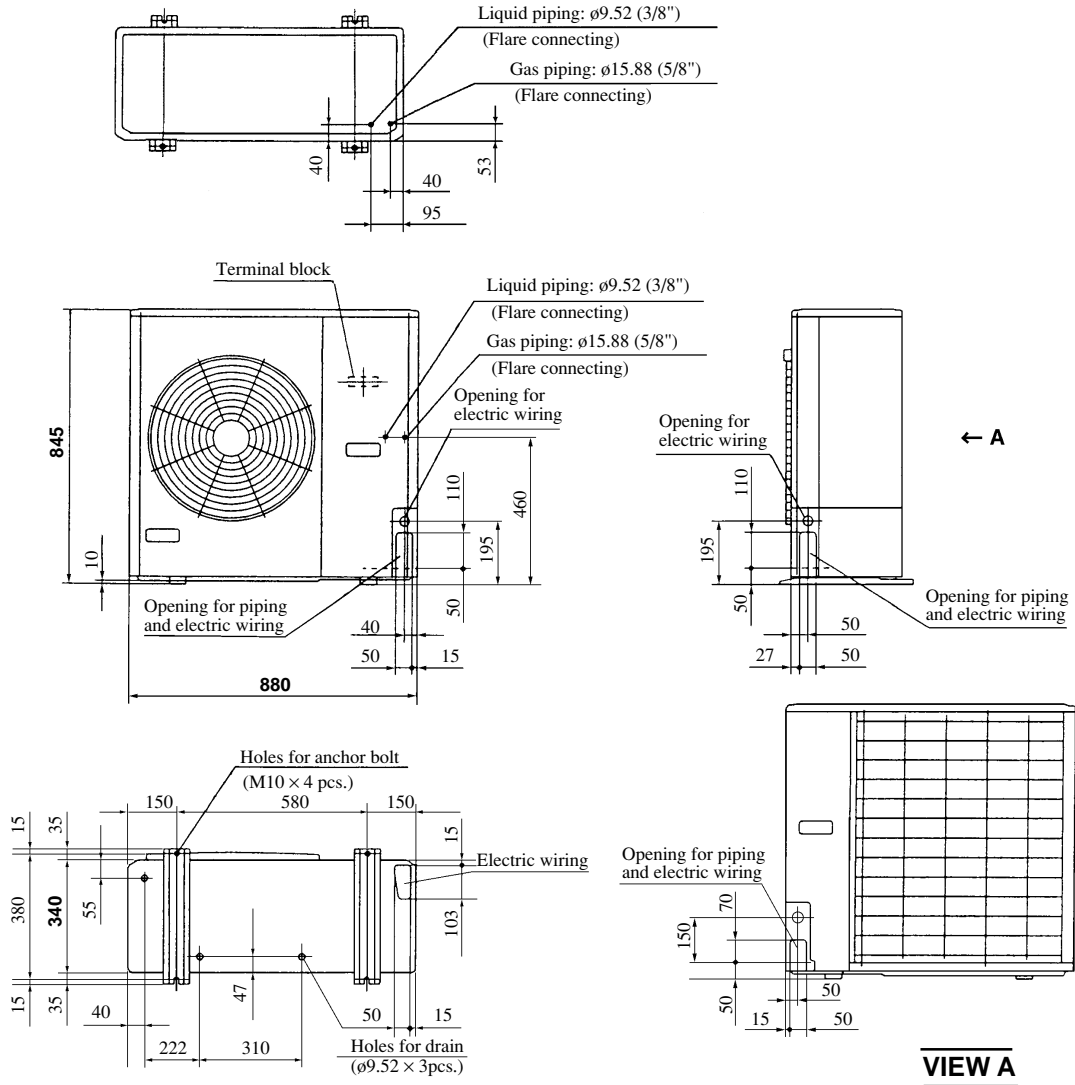

Required space for maintenance and air flow

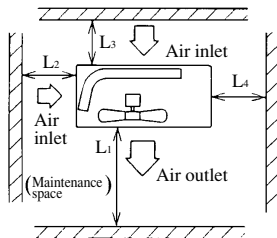

Minimum allowable space to the obstacles

Unit:mm

Mark	Installation type	Unit:mm		
		I	II	III
L ₁	Open	Open	500	
L ₂	300	5	Open	
L ₃	100	150	100	
L ₄	5	5	5	

Notes

- (1) Avoid the location where four sides are entirely surrounded by walls.
- (2) Fix the unit by anchor bolts without fail. Restrict the protrusion length of anchor bolt to 15 mm and under.
- (3) When strong wind blows against the unit, direct the discharge port at a right angle to the wind direction.
- (4) Secure the space of 1 m and over at the top of unit.
- (5) Make the height of obstruction wall in front of discharge port lower than the height of unit.

17.2.4 Exterior appearance

- (1) Indoor unit
Models All models

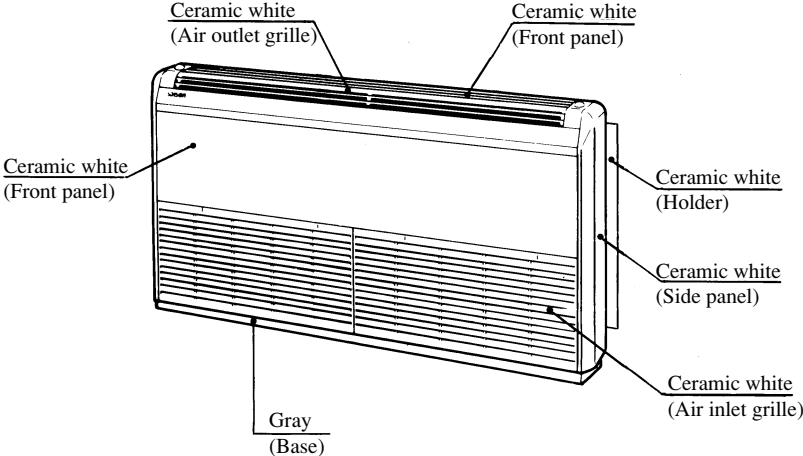

- (2) Outdoor unit
Models FDC258HEN3A, 308HEN3, 308HES3

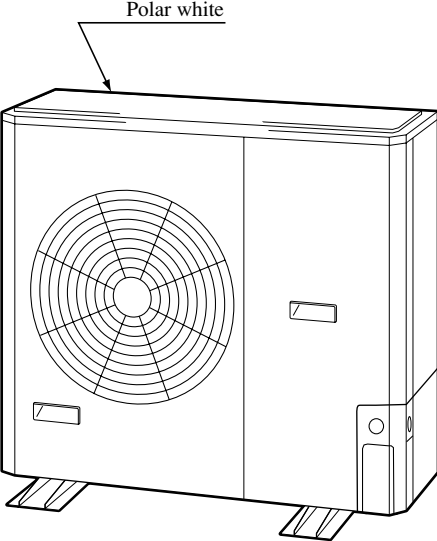

17.2.5 Piping system

Model **FDFL258HEN-SA**

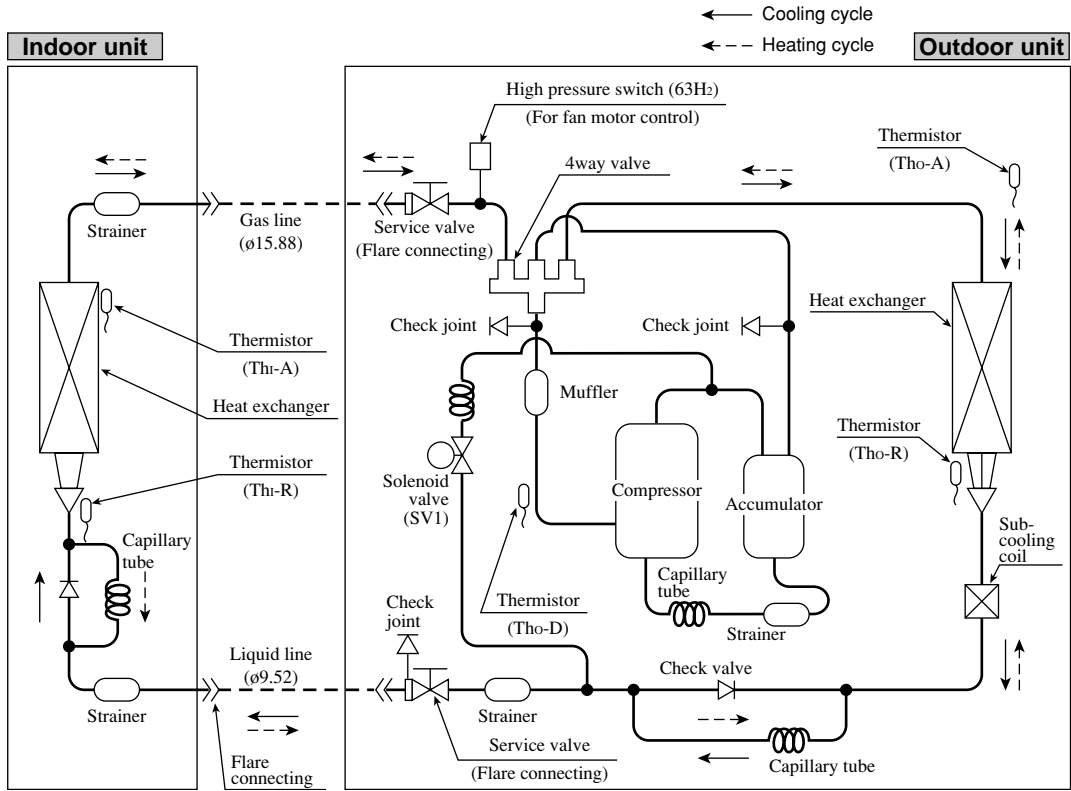

Models **FDFL308HEN-SA, 308HES-SA**

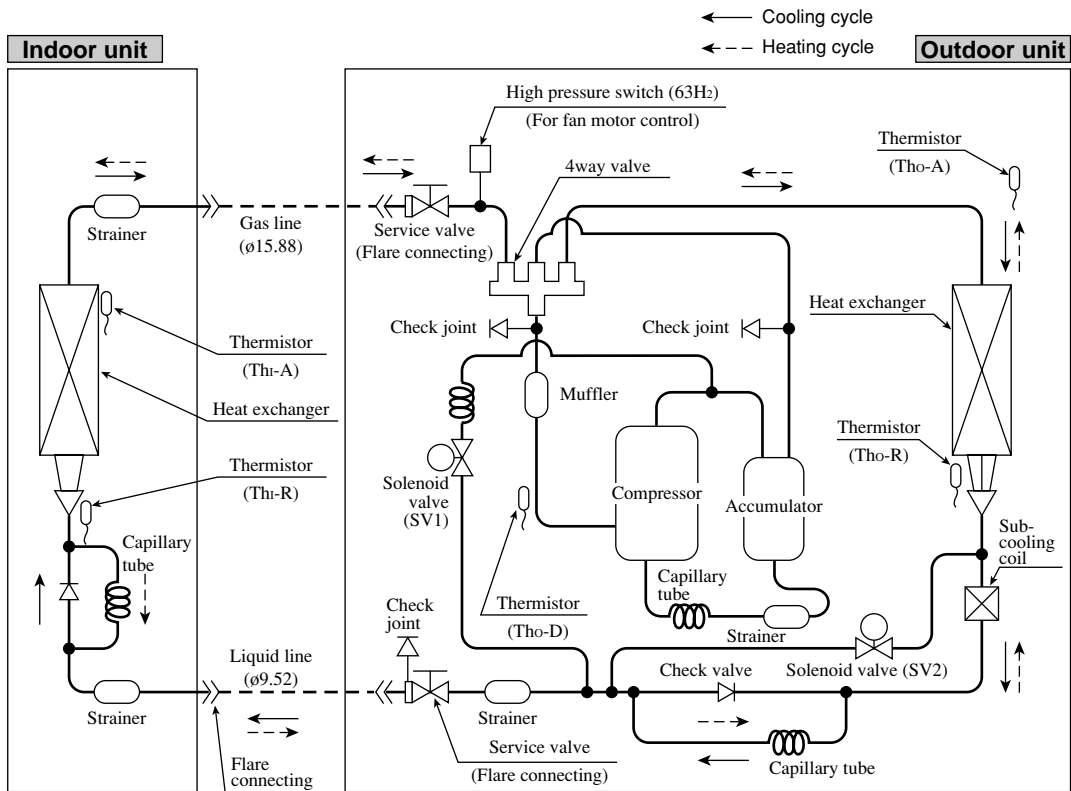

Preset point of the protective devices

Parts name	Mark	Equipped unit	All models
Thermistor (for protection overloading in heating)	Th-R	Indoor unit	OFF 68°C ON 61°C
Thermistor (for frost prevention)			OFF 2.5°C ON 10°C
Thermistor (for detecting discharge pipe temp.)	Tho-D	Outdoor unit	OFF 135°C ON 90°C
Thermistor (for detecting heat exchange temp.)	Tho-R	Outdoor unit	OFF 70°C ON 60°C
High pressure switch (for controlling FM ₀)	63H ₂	Outdoor unit	OFF 2.5MPa (25.5 Kgf/cm ²) ON 2.06MPa (21 kgf/cm ²)

17.2.6 Selection chart

Correct the cooling and heating capacity in accordance with the conditions as follows. The net cooling and heating capacity can be obtained in the following way.

Net capacity = Capacity shown on specification × Correction factors as follows.

(1) Coefficient of cooling and heating capacity in relation to temperatures

Model FDFL258HEN-SA

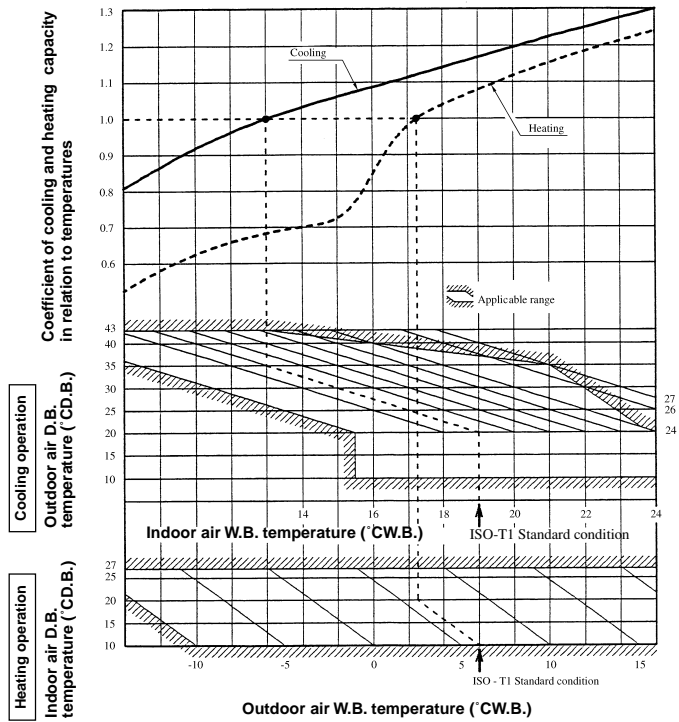

Models FDFL308HEN-SA, 308HES-SA

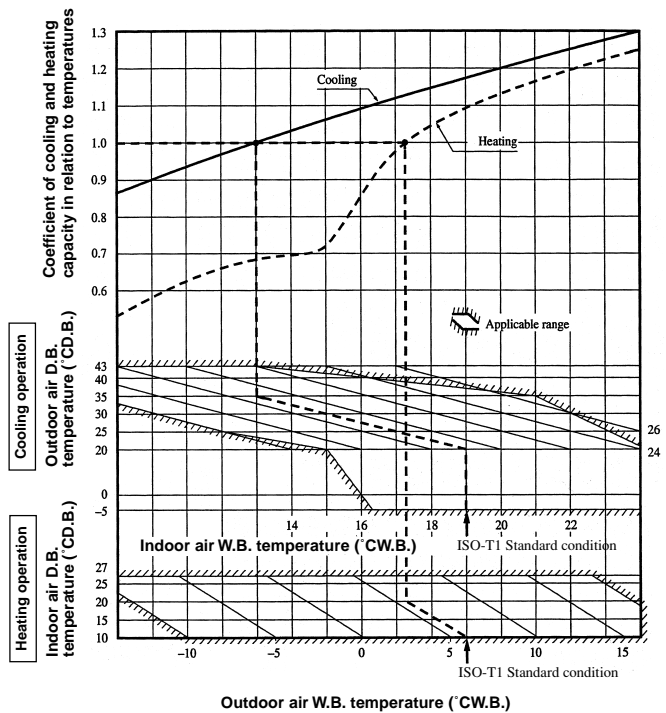

FDFL-H

Table of bypass factor

Item	Model	FDFL 258 type	FDFL 308 type
	Air flow	Hi	0.030
	Lo	0.013	0.018

(2) Correction of cooling and heating capacity in relation to air flow rate control (fan speed)

Coefficient: 1.00 at High, 0.95 at Low

(3) Correction of cooling and heating capacity in relation to one way length of refrigerant piping

It is necessary to correct the cooling and heating capacity in relation to the one way equivalent piping length between the indoor and outdoor units.

Equivalent piping length ⁽¹⁾ m		5	10	15	20	25	30	35	40	45	50	55
Heating		1.0	1.0	1.0	1.0	1.0	0.995	0.995	0.99	0.99	0.985	0.985
Cooling	FDFL258 type	1.0	0.995	0.99	0.985	0.98	0.975	0.97	—	—	—	—
	FDFL308 type	1.0	0.99	0.98	0.97	0.96	0.95	0.94	0.93	0.92	0.91	0.9

Note (1) Equivalent piping length can be obtained by calculating as follows.

258, 308 series [φ15.88(5/8")]: Equivalent piping length = Real piping length + (0.10 × Number of bends in piping)

[Equivalent piping length < Limitation length of piping + 5m]

(4) When the outdoor unit is located at a lower height than the indoor unit in cooling operation and when the outdoor unit is located at a higher height than the indoor unit in heating operation, the following values should be subtracted from the values in the above table.

Height difference between the indoor unit and outdoor unit in the vertical height difference	5m	10m	15m	20m	25m	30m
Adjustment coefficient	0.01	0.02	0.03	0.04	0.05	0.06

Piping length limitations

Item	Model	FDFL258 type	FDFL308 type
Max. one way piping length		30m	50m
Max. vertical height difference		Outdoor unit is higher 20m	Outdoor unit is higher 30m
		Outdoor unit is lower 15m	Outdoor unit is lower 15m

Note (1) Values in the table indicate the one way piping length between the indoor and outdoor units.

How to obtain the cooling and heating capacity

Example : The net cooling capacity of the model FDFL308HEN-SA with the air flow "High", the piping length of 15m, the outdoor unit located 5m lower than the indoor unit, indoor wet-bulb temperature at 19.0 °C and outdoor dry-bulb temperature 35 °C is

$$\text{Net cooling capacity} = \frac{7100}{\text{FDFL308HEN-SA}} \times \frac{1.00}{\text{Air flow "High"}} \times \frac{(0.98 - 0.01)}{\text{Length 15m. Height difference 5 m}} \times \frac{1.0}{\text{Factor by air temperatures}} = 6887 \text{ w}$$

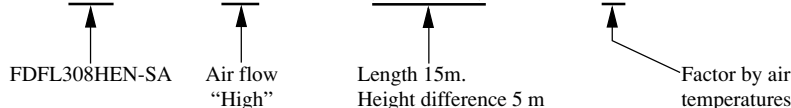

17.2.7 Noise level

Notes (1) The data are based on the following conditions.

Ambient air temperature:

Indoor unit 27°C DB, 19°C WB.

Outdoor unit 35°C DB

Indoor unit

Measured based on JIS B 8616

Mike position as below

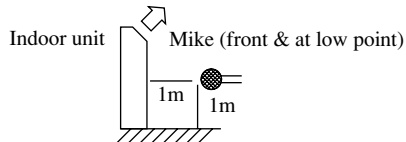

Outdoor unit

Measured on JIS B 8616

Mike position: at highest noise level

in position as below

Distance from front side 1m

Height 1m

(2) The data in the chart are measured in an unechonic room.

(3) The noise levels measured in the field are usually higher than the data because of reflection.

(1) Indoor unit

Model FDFL258-A

Noise level 44 dB (A) at HIGH
39 dB (A) at LOW

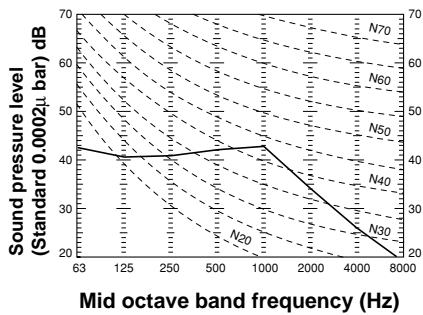

Model FDFL308-A

Noise level 45 dB (A) at HIGH
39 dB (A) at LOW

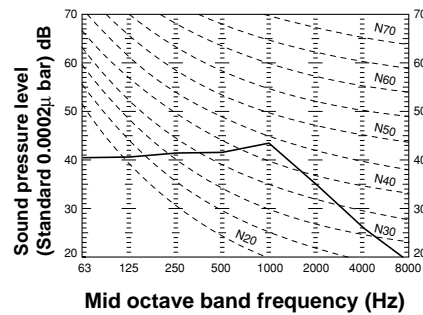

(2) Outdoor unit

Model FDC258HEN3A

Noise level 52 dB (A)

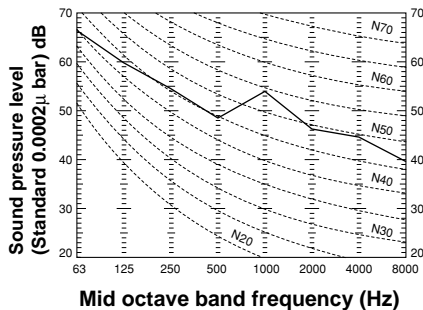

Models FDC308HEN-S, 308HES-S

Noise level 52 dB (A)

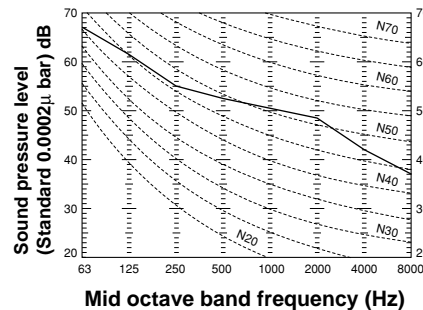

17.3 ELECTRICAL DATA

17.3.1 Electrical wiring

Model FDFL258HEN-SA

Power source
1 Phase 220/240V 50Hz

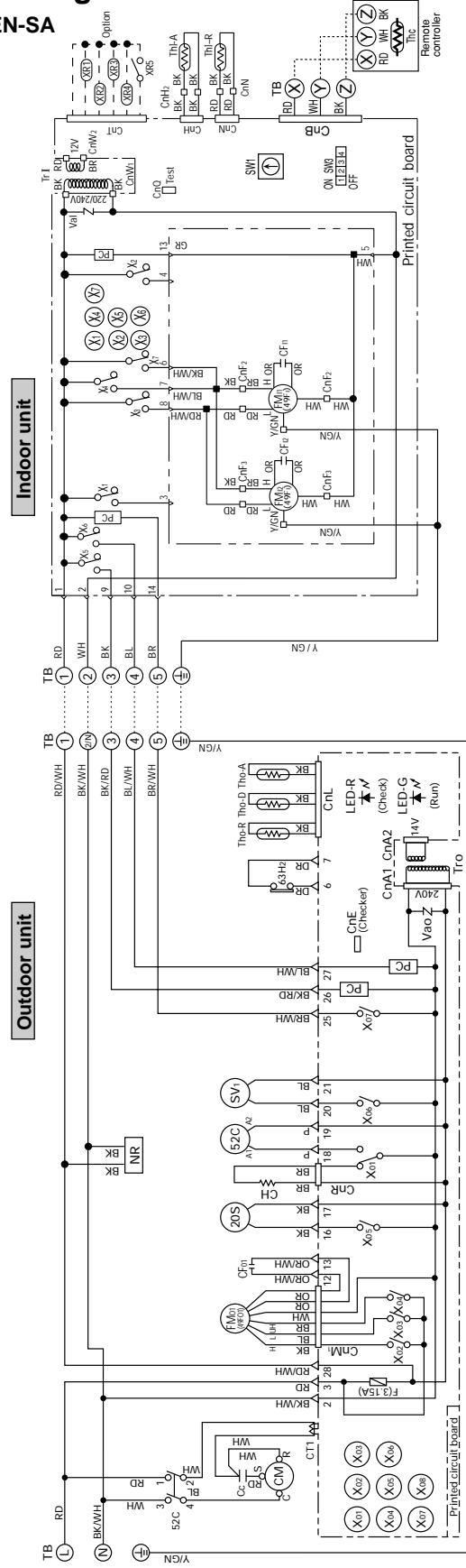

Meaning of marks

Mark	Parts name	Mark	Parts name
CC	Capacitor for CM	Tho-A	Thermistor
CF1,2	Capacitor for FM1	Tho-D	Thermistor
CFo	Capacitor for FMo	Tho-R	Thermistor
CH	Crankcase heater	T1	Transformer (Indoor unit)
CM	Compressor motor	T1o	Transformer (Outdoor unit)
CMa ~ W	Compressor motor (mark)	Val	Valve
CT1	Current sensor	Vao	4-way valve solenoid
F	Fuse	20S	Internal thermostat for FM1
FM1,2	Fan motor (Indoor unit)	49Fi	Internal thermostat for FMo
FMo	Fan motor (Outdoor unit)	49Fo	Magnetic contactor for CM
NR	Surge suppressor	52C	Auxiliary relay
PC	Photo coupler	X1-7	High pressure switch (for control)
SC	Solenoid coil (for control)	SV1	Terminal block (for control)
SW1	Switch (Address set)	SW3	Terminal block (mark)
SW3	Changeover switch	TB	Thermistor
Thi-A	Thermistor	Thi-R	Thermistor
Thi-R	Thermistor		

Color mark

Mark	Color	Mark	Color
BK	Black	BK/RD	Black/Red
BL	Blue	BL/WH	Black/White
BR	Brown	BL/WH	Blue/White
GR	Gray	BR/WH	Brown/White
OR	Orange	OR/WH	Orange/White
P	Pink	RD/WH	Red/White
RD	Red	Y/GN	Yellow/Green
WH	White		

Model FDFL308HEN-SA

**Power source
1 Phase 220/240V 50Hz**

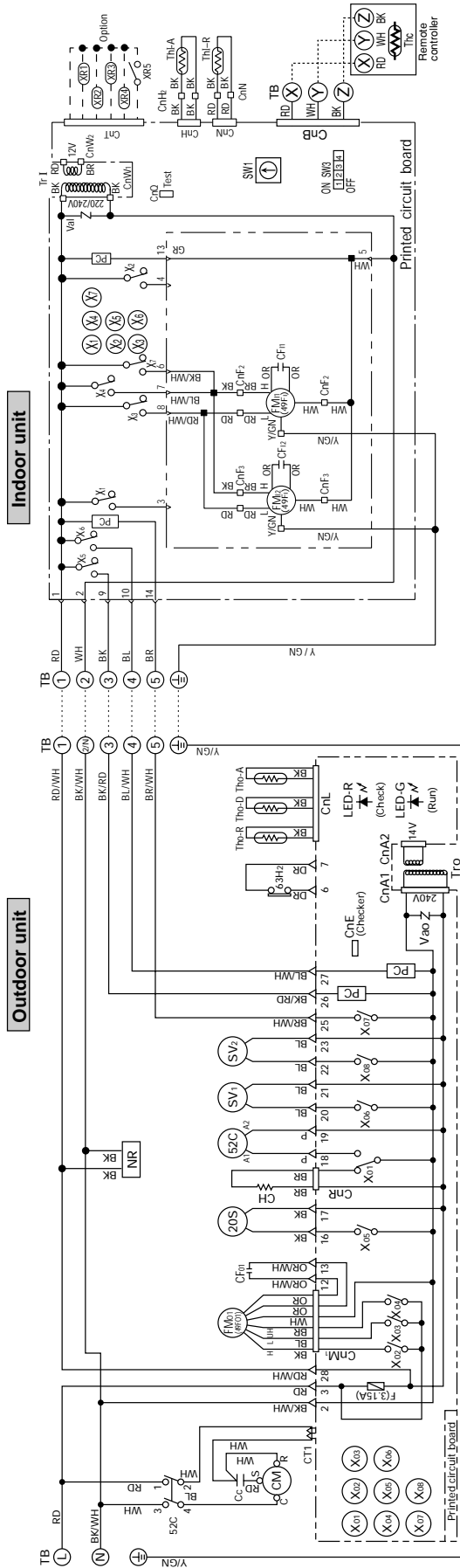

Meaning of marks

Mark	Parts name	Mark	Parts name
CC	Capacitor for CM	Tho-A	Thermistor
CF1,2	Capacitor for FM1	Tho-D	Thermistor
CF0	Capacitor for FM0	Tho-R	Thermistor
CH	Crankcase heater	Tr1	Transformer (Indoor unit)
CM	Compressor motor	Tr0	Transformer (Outdoor unit)
CnA ~ W	Connector (□ mark)	Val	Valvistor
CT1	Current sensor	Vao	Variistor
F	Fuse	20S	4-way valve solenoid
FM1,2	Fan motor (Indoor unit)	49F1	Internal thermostat for FM1
FM0	Fan motor (Outdoor unit)	49F0	Internal thermostat for FM0
NR	Surge suppressor	52C	Magnetic contactor for CM
PC	Photo coupler	X11-7	Auxiliary relay
SV1,2	Solenoid coil (for control)	X01-08	High pressure switch (for control)
SW1	Switch (Address set)	63H2	Terminal (F)
SW3	Changeover switch	▽	Connector
Terminal block (O mark)		LED-G	Indication lamp (Green)
Th-A	Thermistor	LED-R	Indication lamp (Red)
Th-R	Thermistor		

Color mark

Mark	Color	Mark	Color
BK	Black	BK/RD	Black/Red
BL	Blue	BL/WH	Black/White
BR	Brown	BL/WH	Blue/White
GR	Gray	BR/WH	Brown/White
OR	Orange	OR/WH	Orange/White
P	Pink	RD/WH	Red/White
RD	Red	Y/GN	Yellow/Green
WH	White		

Model FDFL308HES-SA

Power source
3 Phase 380/415V 50Hz

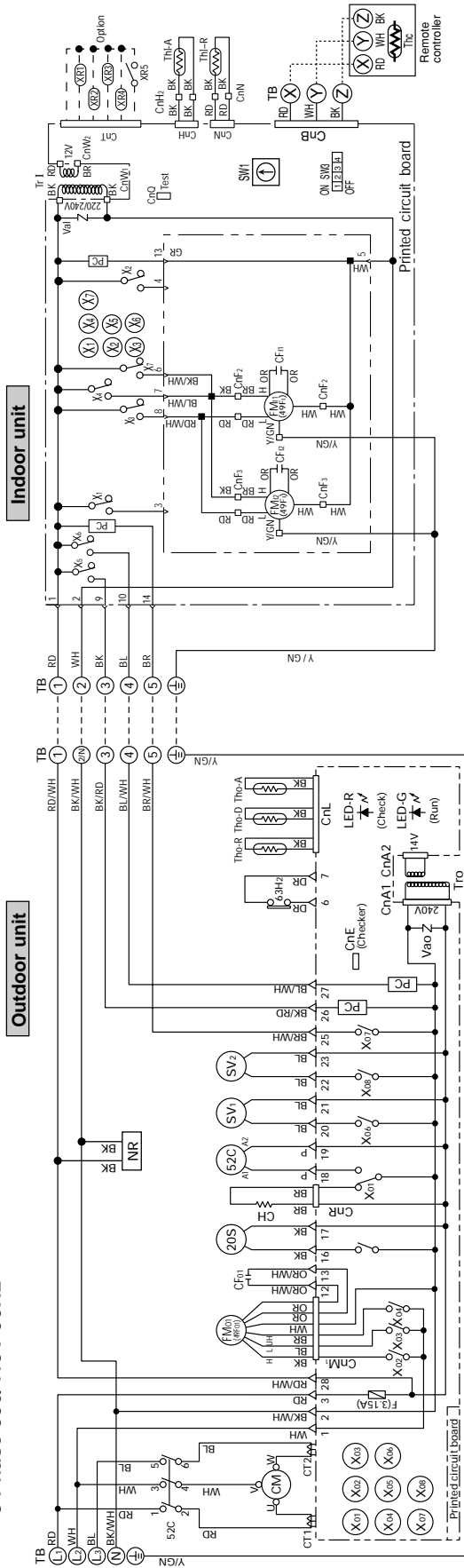

Meaning of marks

Mark	Parts name	Mark	Parts name
CF1r.2	Capacitor for FMI	Tho-D	Thermistor
CF01	Capacitor for FMO	Tho-R	Thermistor
CH	Crankcase heater	Tri	Transformer (Indoor unit)
CM	Compressor motor	Tro	Transformer (Outdoor unit)
CnA ~ Z	Connector (□ mark)	Val	Valvistor
CT1.2	Current sensor	Vao	Variator
F	Fuse	20S	4-way valve solenoid
FM1r.2	Fan motor (Indoor unit)	49F1	Internal thermostat for FMI
FM01	Fan motor (Outdoor unit)	49F01	Internal thermostat for FMO
NR	Surge suppressor	52C	Magnetic contactor for CM
PC	Photo coupler	X11-7	Auxiliary relay
SV1,2	Solenoid coil (for control)	X01-08	Auxiliary relay
SW1	Switch (Address set)	63H2	High pressure switch (for control)
SW3	Changeover switch	▽	Terminal (F)
TB	Terminal block (□ mark)	○	Connector
Th-A	Thermistor	○	Indication lamp (Green)
Th-R	Thermistor	○	Indication lamp (Red)
Tho-A	Thermistor		

Color mark

Mark	Color	Mark	Color
BK	Black	BK/RD	Black/Red
BL	Blue	BL/WH	Black/White
BR	Brown	BL/WH	Blue/White
GR	Gray	BR/WH	Brown/White
OR	Orange	OR/WH	Orange/White
P	Pink	RD/WH	Red/White
RD	Red	Y/GN	Yellow/Green
WH	White		

17.4 OUTLINE OF OPERATION CONTROL BY MICROCOMPUTER

Same as the cooling/heating equipment for FDT(N) heat pump type. Refer to page 317.

17.5 APPLICATION DATA

SAFETY PRECAUTIONS

- Please read these “Safety Precautions” first then accurately execute the installation work.
 - Though the precautionary points indicated herein are divided under two headings, **⚠WARNING** and **⚠CAUTION**, those points which are related to the strong possibility of an installation done in error resulting in death or serious injury are listed in the **⚠WARNING** section. However, there is also a possibility of serious consequences in relationship to the points listed in the **⚠CAUTION** section as well.
- In either case, important safety related information is indicated, so by all means, properly observe all that is mentioned.
- After completing the installation, along with confirming that no abnormalities were seen from the operation tests, please explain operating methods as well as maintenance methods to the user (customer) of this equipment, based on the owner’s manual. Moreover, ask the customer to keep this sheet together with the owner’s manual.

⚠ WARNING

- This system should be applied to places of office, restaurant, residence and the like. Application to inferior environment such as engineering shop could cause equipment malfunction.
- Please entrust installation to either the company which sold you the equipment or to a professional contractor. Defects from improper installations can be the cause of water leakage, electric shocks and fires.
- Execute the installation accurately, based on following the installation manual. Again, improper installations can result in water leakage, electric shocks and fires.
- When a large air-conditioning system is installed to a small room, it is necessary to have a prior planned countermeasure for the rare case of a refrigerant leakage, to prevent the exceeding of threshold concentration. In regards to preparing this countermeasure, consult with the company from which you purchased the equipment, and make the installation accordingly. In the rare event that a refrigerant leakage and exceeding of threshold concentration does occur, there is the danger of a resultant oxygen deficiency accident.
- For installation, confirm that the installation site can sufficiently support heavy weight. When strength is insufficient, injury can result from a falling of the unit.
- Execute the prescribed installation construction to prepare for earthquakes and the strong winds of typhoons and hurricanes, etc. Improper installations can result in accidents due to a violent falling over of the unit.
- For electrical work, please see that a licensed electrician executes the work while following the safety standards related to electrical equipment, and local regulations as well as the installation instructions, and that only exclusive use circuits are used.
Insufficient power source circuit capacity and defective installment execution can be the cause of electric shocks and fires.
- Accurately connect wiring using the proper cable, and insure that the external force of the cable is not conducted to the terminal connection part, through properly securing it. Improper connection or securing can result in heat generation or fire.
- Take care that wiring does not rise upward, and accurately install the lid/service panel. Its improper installation can also result in heat generation or fire.
- When setting up or moving the location of the air-conditioner, do not mix air etc. or anything other than the designated refrigerant (R22) within the refrigeration cycle.
Rupture and injury caused by abnormal high pressure can result from such mixing.
- Always use accessory parts and authorized parts for installation construction. Using parts not authorized by this company can result in water leakage, electric shock, fire and refrigerant leakage.

⚠ CAUTION

- Execute proper grounding. Do not connect the ground wire to a gas pipe, water pipe, lightning rod or a telephone ground wire. Improper placement of ground wires can result in electric shock.
- The installation of an earth leakage breaker is necessary depending on the established location of the unit. Not installing an earth leakage breaker may result in electric shock.
- Do not install the unit where there is a concern about leakage of combustible gas.
The rare event of leaked gas collecting around the unit could result in an outbreak of fire.
- For the drain pipe, follow the installation manual to insure that it allows proper drainage and thermally insulate it to prevent condensation. Inadequate plumbing can result in water leakage and water damage to interior items.

NOTICE

All Wiring of this installation must comply with NATIONAL, STATE AND LOCAL REGULATIONS. These instructions do not cover all variations for every kind of installation circumstance. Should further information be desired or should particular problems occur, the matter should be referred to Mitsubishi Heavy Industries, Ltd. through your local distributor.

WARNING

BE SURE TO READ THESE INSTRUCTIONS CAREFULLY BEFORE BEGINNING INSTALLATION. FAILURE TO FOLLOW THESE INSTRUCTIONS COULD CAUSE SERIOUS INJURY OR DEATH, EQUIPMENT MALFUNCTION AND/OR PROPERTY DAMAGE.

17.5.1 Installation of indoor unit

(1) Selection of installation location

- (a) A place where good air circulation and delivery can be obtained.

Air reach		Unit: m
Models	All models	
Air reach	5	

Conditions

- (1) Fan speed . . . High
 - (2) Air flow speed at reach point . . . 0.5 m/sec.
- (b) A place where a floor or wall has enough strength to mount the unit.
 - (c) A place where there is no obstruction to the return air inlet and supply air outlet ports.
 - (d) A place where there is no moist air or oil vapor which may harm the heat exchanger.
 - (e) A place where the space shown below may be secured.

Floor standing installation

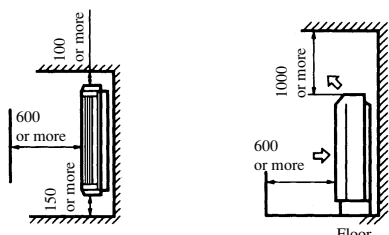

Wall mounted installation

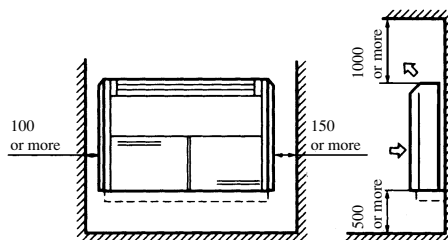

Unit: mm

- (f) The unit uses a microcomputer as a control device. Therefore avoid installing the unit near the equipment that generates strong electromagnetic noise.

(2) Installation of unit

(a) Floor standing installation

- 1) Positions of mounting bracket fixing bolts
Drill holes by referring to figures below.

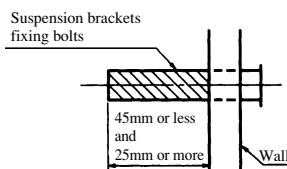
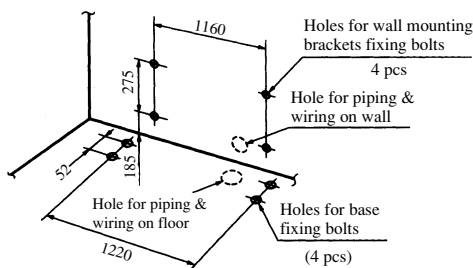

Note (1) The suspension brackets fixing bolts should be mounted to the length as shown in the above figure, the bolts ends will be recessed inside the cap on the unit.

- 2) Fix the mounting brackets on a wall.
The positions of the brackets should be attached so the brackets face inside.

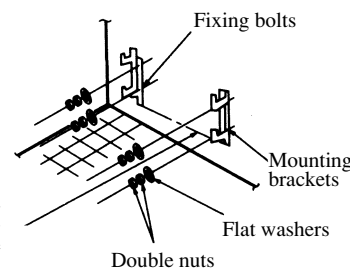

Install the suspension brackets so that this plane will be level or will have a gentle incline toward the right. (left and right side height difference should be from 0 to 0.1 in.)

- 3) Mount the unit on the mounting brackets.

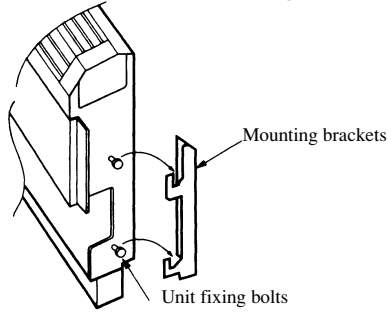

- 5) Assemble the side panels.

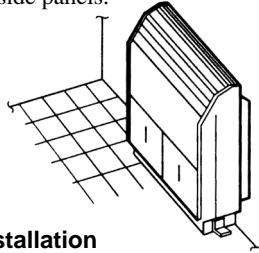

- 4) Fix the unit on the floor by using the fixing brackets.

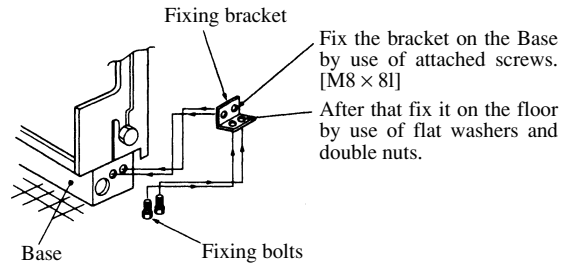

(b) Wall mounted installation

- 1) Fix the mounting brackets on a wall.

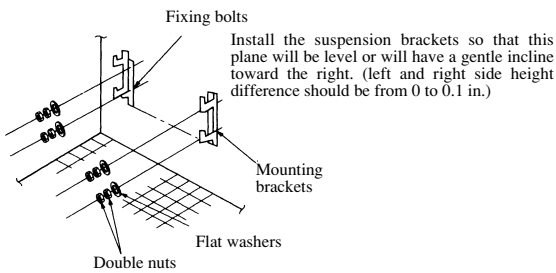

Note (1) Location of the mounting brackets fixing bolts are the same as those for the floor standing installation except the location height.

- 3) Assemble the side panels.

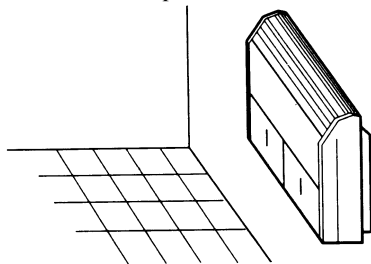

- 2) Suspend the unit on the mounting brackets.

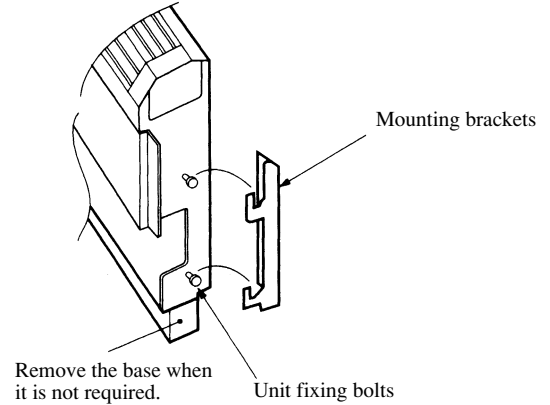

Note (1) The figure on the left shows the wall mounted installation when the base is removed.

(3) Drain piping

The drain piping can be directed to the floor or rear sides as follows.

- (a) Connect a drain piping to the drain outlet and fix it by use of tightening band.

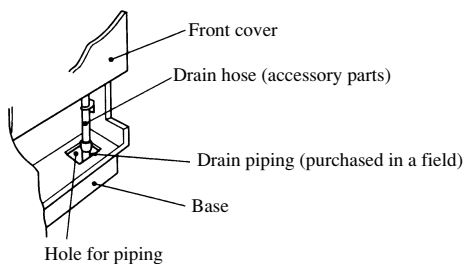

- (b) Indoor side drain piping must be thermally insulated.
 (c) After finishing the drain piping check the drainage by pouring some water in the drain pan.

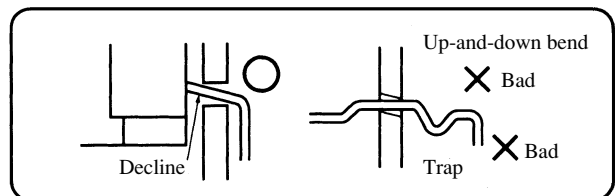

(4) Installation of remote controller (on the main unit)

Attached remote controller may be installed on the main unit as shown below. The work can be done on the spot when the customer asks so or by other reasons.

Refer to the next page when it is installed on the wall.

necessary parts (Prepare following parts on the spot.)

- Tapping screw (M4 × L12) × 2 pcs.
- Tie band
- Vinyl tape

(a) Boring of mounting hole on the front panel

Remove the front panel and bore the hole of following size.

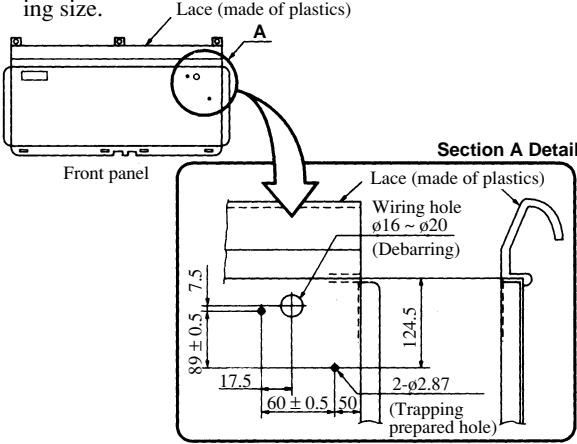

(b) Protection of edge

Make smooth the periphery of the 16 ~ 20 hole with vinyl tape, etc.

(this is indispensable to protect cables.)

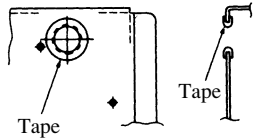

(c) Installation of remote controller

Install the lower case with tapping screws (M4 × L12).

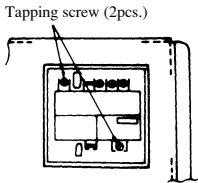

(d) Wiring of remote controller cables

- Use the attached cables and connect between the remote controller and the terminals (X-red, Y-white, Z-black) of control box.
- Make sure to give an extra length of about 50 cm to the cables. (Because the front panel may be removed for maintenance.)
- Peel the cable cover as shown below and solder the wires on the terminals. (Unless they are soldered, they may become loose.)

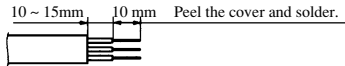

(e) Installation of front panel

Take out the cables through the insulating section of the drain pan.

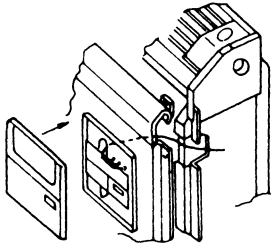

(f) Arrangement of cables

Fasten the excessive length of the cable with the tie bands.

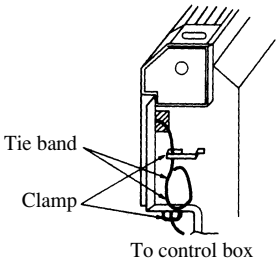

(g) Installation of side panel

The work is completed when the side panel is installed.

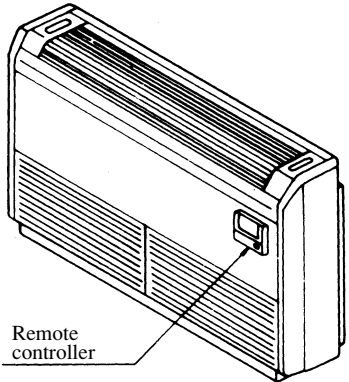

17.5.2 Installation of outdoor unit

Same as the cooling/heating equipment for FDT(N) heat pump type. Refer to page 338.

17.6 MAINTENANCE DATA

Same as the cooling/heating equipment for FDT(N) heat pump type. Refer to page 348.