



SERVICE MANUAL

MIDEA AIRCONDITIONER
EUROPE MARKET
DC INVERTER MULTI TYPE

R DC INVERTER MULTI SERIES

2. Function

2.1 Model Names of Indoor units

	Capacity	Indoor units
DC Inverter Multi Series	7k	MDSRI-07HRDN1
	9k	MDSRI-09HRDN1
	12k	MDSRI-12HRDN1
	18k	MDSRI-18HRDN1

2.2 Product features

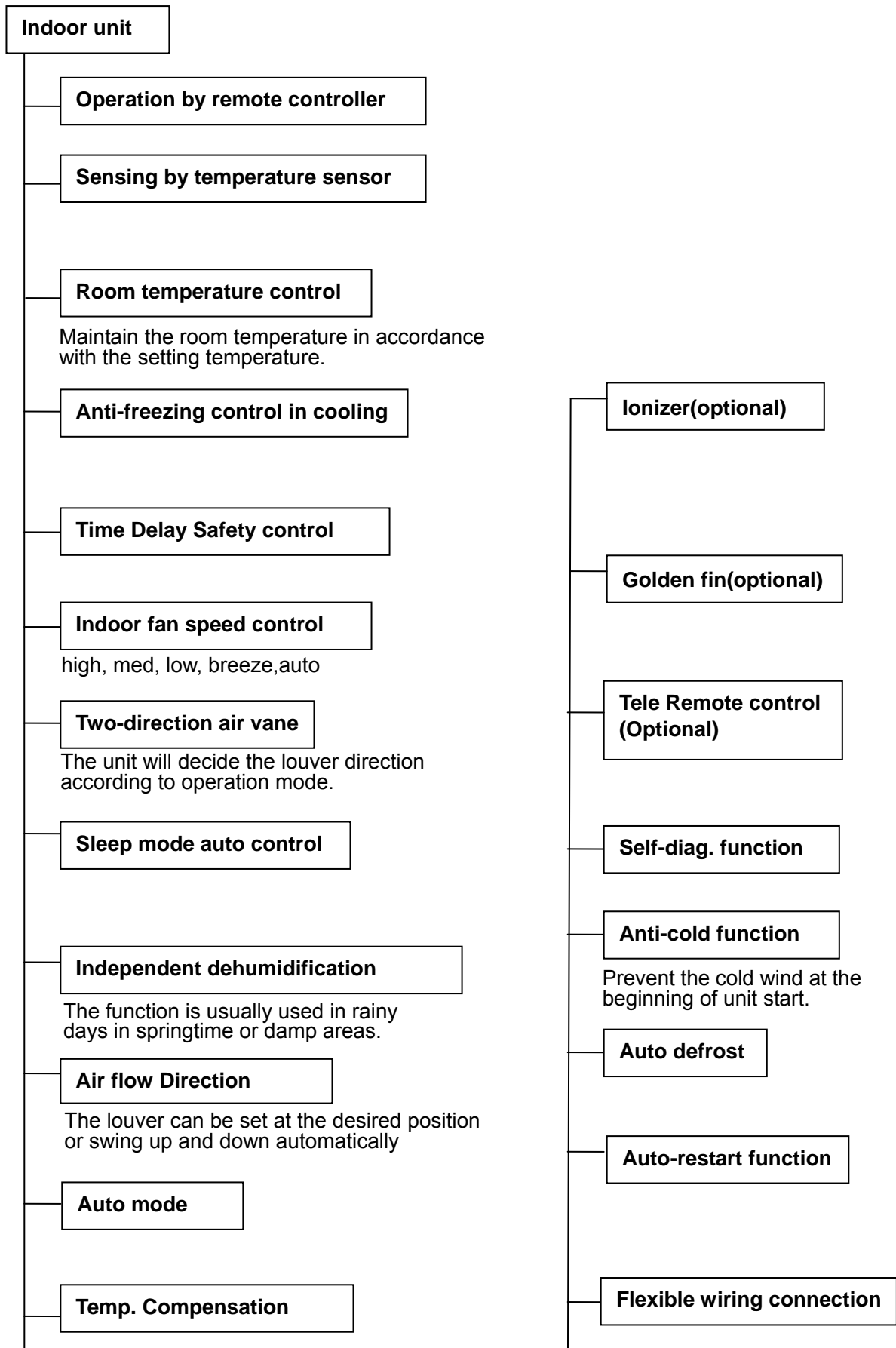

3. Dimension

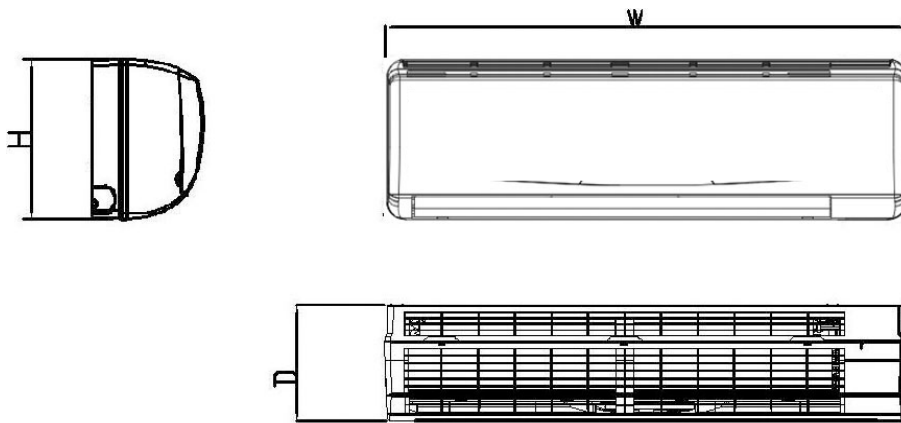

Model	W	H	D
MDSRI-07HRDN1	710	250	189
MDSRI-09HRDN1			
MDSRI-12HRDN1	790	275	196
MDSRI-18HRDN1	930	275	198

Position of installation board

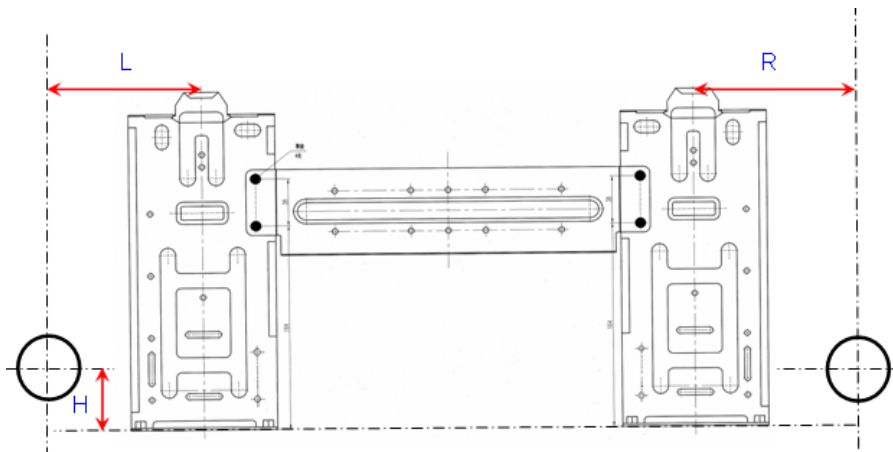

Model	R(mm)	L(mm)	H(mm)	Dimension of installation hole(mm)
MDSRI-07HRDN1	111.5	100	45	φ65
MDSRI-09HRDN1	111.5	100	45	φ65
MDSRI-12HRDN1	83.5	100	45	φ65
MDSRI-18HRDN1	207	150	45	φ65

4. Wiring Diagram

MDSRI-07HRDN1 MDSRI-09HRDN1

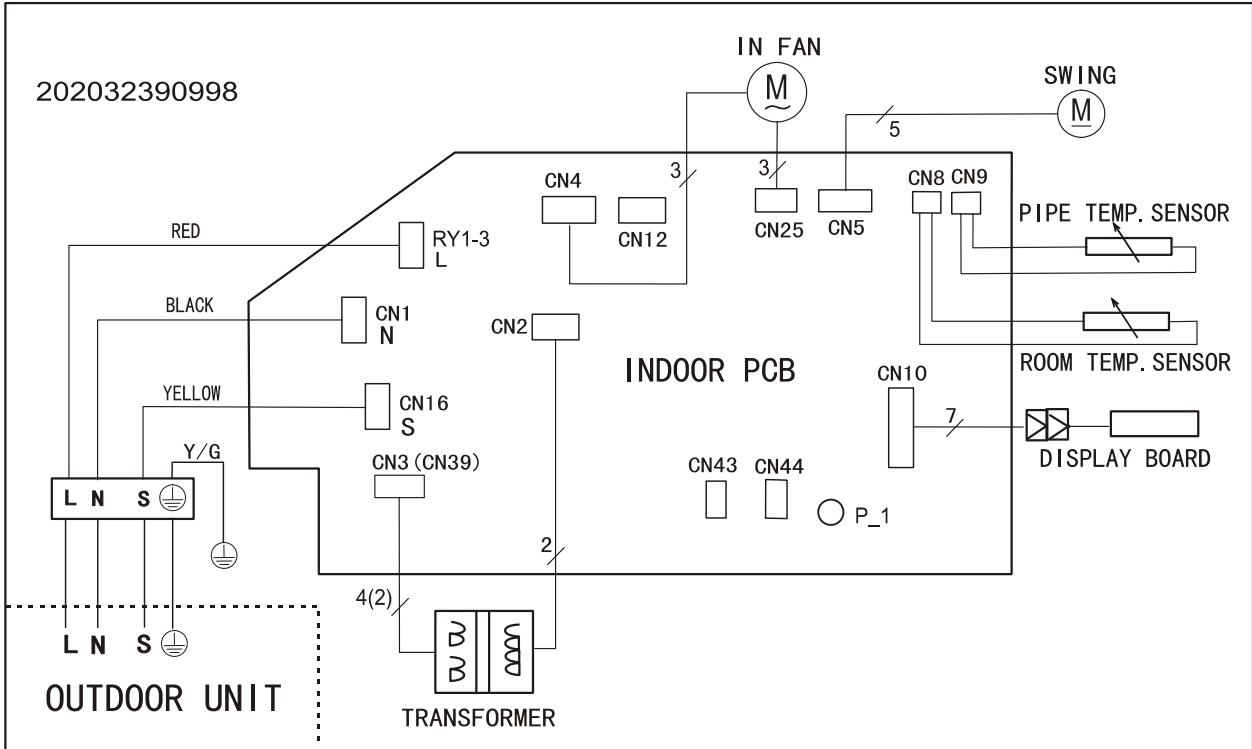

MSRI-12HRDN1 MSRI-18HRDN1

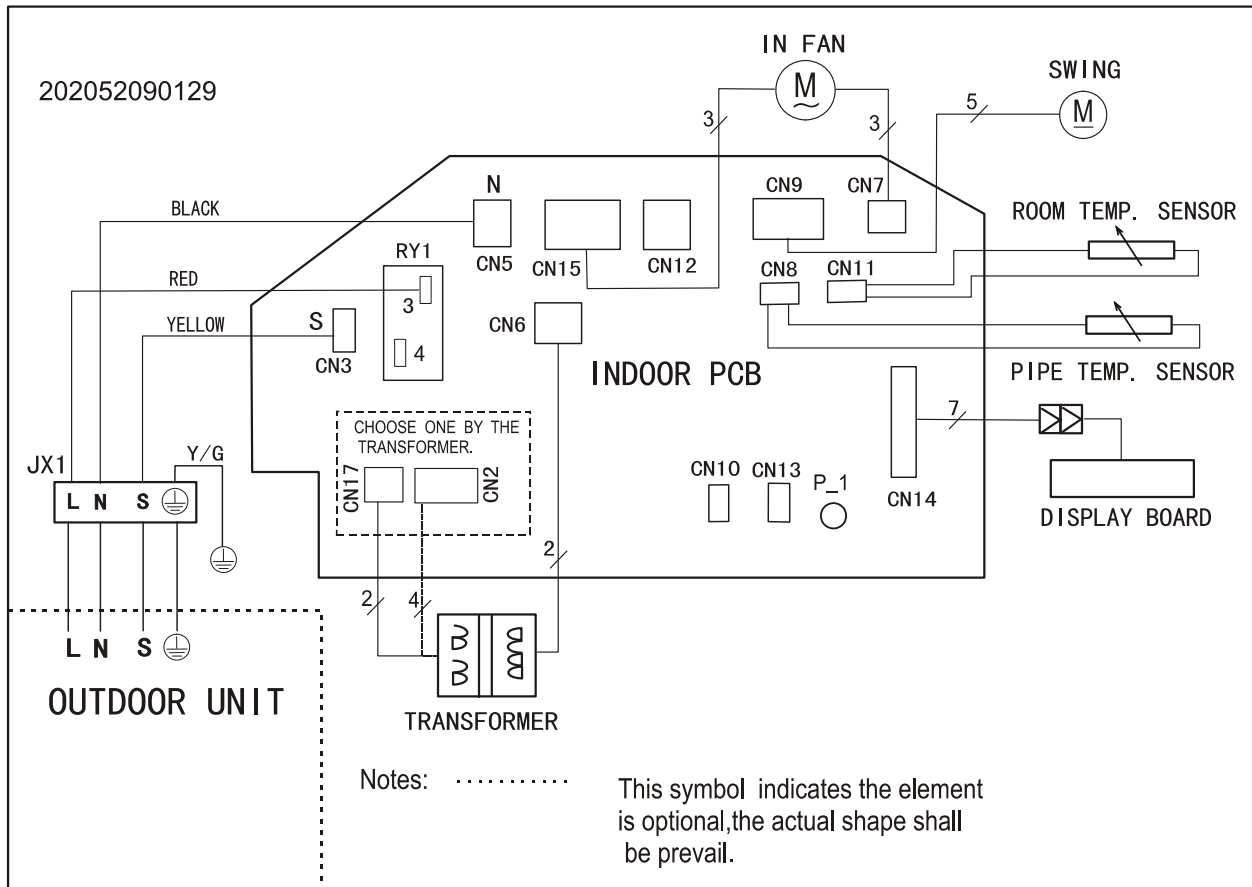

5. Operation characteristics

Temperature Mode	Cooling operation	Heating operation	Drying operation
Room temperature	$\geq 17^{\circ}\text{C}$	$\leq 30^{\circ}\text{C}$	$\geq 17^{\circ}\text{C}$
Outdoor temperature	$0^{\circ}\text{C} \sim 50^{\circ}\text{C}$	$-15^{\circ}\text{C} \sim 24^{\circ}\text{C}$	$0^{\circ}\text{C} \sim 50^{\circ}\text{C}$

CAUTION:

1. If the air conditioner is used beyond the above conditions, certain safety protection features may come into operation and cause the unit to operate abnormally.

2. The room relative humidity should be less than 80%. If the air conditioner operates beyond this figure, the surface of the air conditioner may attract condensation. Please set the vertical air flow louver to its maximum angle (vertically to the floor), and set HIGH fan mode.

3. The optimum performance will be achieved during this operating temperature zone.

6. Electronic function

6.1 Abbreviation

T1: Indoor ambient temperature

T2: Coil temperature of indoor heat exchanger middle.

T2B: Coil temperature of indoor heat exchanger outlet.

T3: Coil temperature of outdoor heat exchanger

T4: Outdoor ambient temperature

T5: Compressor discharge temperature

Ts: Setting temp.

6.3 Main Protection

6.3.1 Three minutes delay at restart for compressor.

6.3.2 Indoor fan delayed open function

----When system starts up, the louver will be active immediately and the indoor fan will open after 10s.

----If the system runs at heating mode, the indoor fan will be also controlled by anti-cold wind function.

6.3.3 Sensor protection at open circuit and breaking disconnection.

6.3.4 Fan speed is out of control.

When Indoor fan speed is too low (lower than 300RPM) lasting 50 seconds, the unit stops and LED displays failure information and can't returns to normal operation automatically.

6.3.5 Zero crossing detection error protection

If AC can not detect zero crossing signal for 4 minutes or the zero crossing signal time interval is not correct, the unit will stop and the LED will display the failure. The correct zero crossing signal time interval should be between 6-13ms.

6.4 Operation Modes and Functions

6.4.1 Fan mode

- (1) The outdoor fan and compressor stop.
- (2) Temperature setting function is disabled, and no setting temperature is displayed.
- (3) Indoor fan can be set to high/med/low/auto.
- (4) The louver operates the same as in cooling mode.
- (5) Auto fan:

The action of auto fan in fan-only mode is the same as auto fan in cooling mode with 24°C setting temperature.

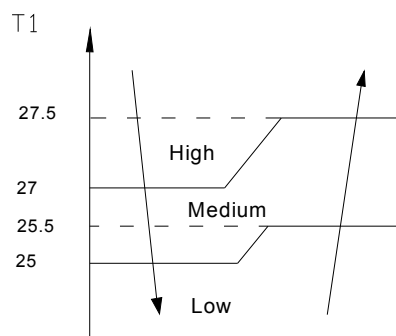

6.4.2 Cooling Mode

6.4.2.1 Compressor running rules:

The compressor will run at corresponding frequency according to the gross amendatory capacity demand.

Frequency(Hz)	0	COOL_F1	COOL_F2	COOL_F11	COOL_F12
Amendatory capacity demand.	0	1	2	11	≧ 12

Meanwhile the maximum running frequency will be adjusted according to the outdoor ambient temp.

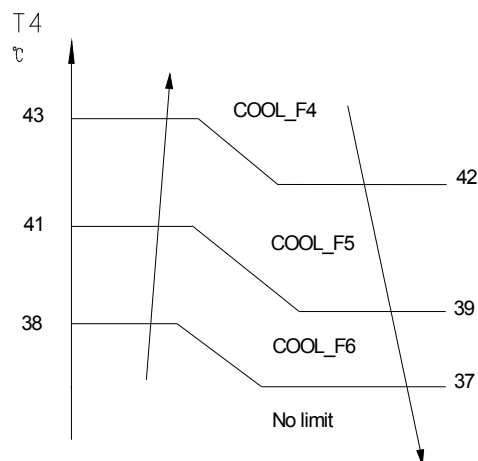

6.4.2.2 Indoor fan running rules

In cooling mode, indoor fan runs all the time and the speed can be selected as high, medium, low and auto.

Auto fan in cooling mode acts as follow:

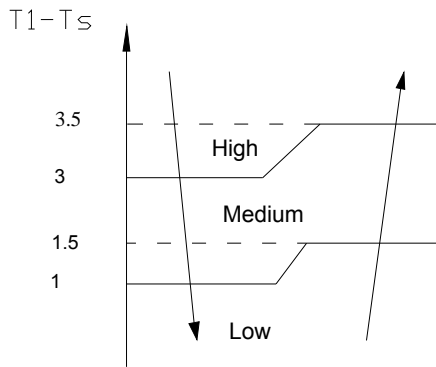

6.4.2.3 Evaporator low temperature T2 protection.

When $T_2 < 4^\circ\text{C}$, the indoor has no capacity demand and resume till $T_2 > 8^\circ\text{C}$.

6.4.2.4 Outdoor fan running rules:

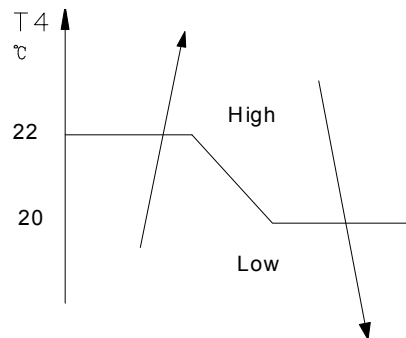

6.4.3 Heating Mode

6.4.3.1 Compressor running rules:

The compressor will run at corresponding frequency according to the gross amendatory capacity demand.

Frequency(Hz)	0	HEAT_F1	HEAT_F2	HEAT_F11	HEAT_F12
Amendatory capacity demand.	0	1	2	11	$\cong 12$

6.4.3.2 Indoor fan running rules:

Indoor fan speed can be set as high, medium, low or auto fan and the anti-cold-wind function is preferential.

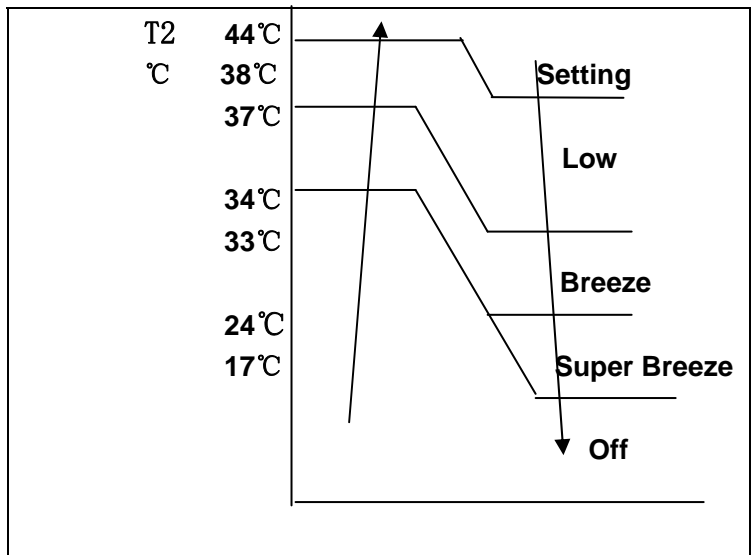

Auto fan action in heating mode.

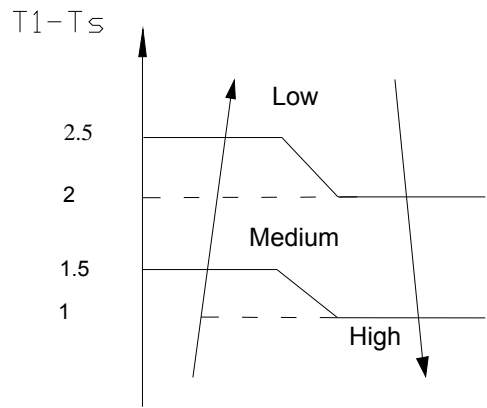

6.4.3.3 Outdoor fan running rules:

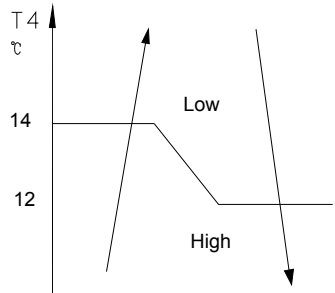

6.4.3.3 High evaporator coil temp.T2 protection:

If $T2 > 63^{\circ}\text{C}$, the indoor unit has no capacity demand and resume till 48°C .

6.4.3.4 Defrosting mode:

Condition of defrosting:

$T3 \cong \text{TCDIN}$ and lasts for 40 minutes. $\text{TCDIN} = -2^{\circ}\text{C}$.

Defrosting action:

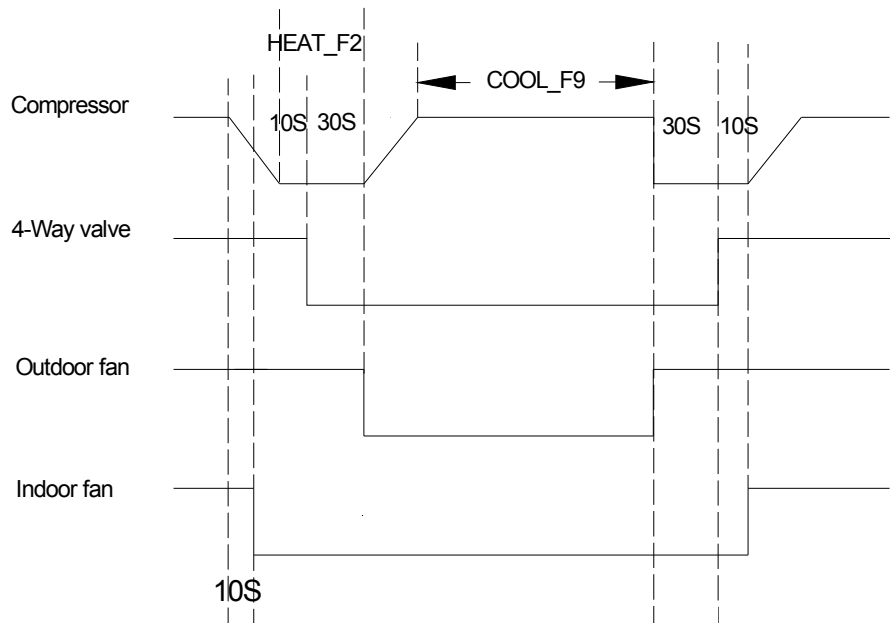

Condition of ending defrosting:

If any one of following items is satisfied, defrosting will stop and the machine will turn to normal heating mode.

- ① $T_3 > TCDE$; $TCDE = 15^\circ\text{C}$.
- ② The defrosting time achieves 10min.

6.4.4 Auto-mode

This mode can be chosen with remote controller and the setting temperature can be changed between $17\sim 30^\circ\text{C}$.

In auto mode, the machine will choose cooling, heating or fan-only mode according to ΔT ($\Delta T = T_1 - T_s$).

$\Delta T = T_1 - T_s$	Running mode
$\Delta T > 1^\circ\text{C}$	Cooling
$-1 \leq \Delta T \leq 1^\circ\text{C}$	Fan-only
$\Delta T < -1^\circ\text{C}$	Heating

Indoor fan will run at auto fan of the relevant mode.

The louver operate same as in relevant mode.

If the machine switches mode between heating and cooling, the compressor will keep stopping for 15 minutes and then rechoose mode according to $T_1 - T_s$.

If the setting temperature is modified, the machine will rechoose running function.

6.4.5 Drying mode

6.4.5.1 Indoor fan speed is fixed at breeze and can't be changed. The louver angle is the same as

in cooling mode.

6.4.5.2 Overflow room temperature protection

In drying mode, if room temperature is lower than 10°C, the indoor fan will stop and not resume until room temperature exceeds 12°C.

6.4.5.3 Evaporator anti-freezing protection are active

6.4.6 Forced operation function

6.4.6.1 Enter forced operation function:

Press the touch button continually, the AC will run as below sequence:

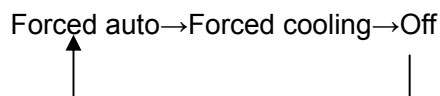

When the machine is off, pressing the touch button will carry the machine to forced auto mode, after this, if pressing the button once again, the machine will turn into forced cooling mode.

In forced cooling mode, pressing touch button will turn off the machine.

6.4.6.2 In forced operation mode, all general protections and remote control are available.

6.4.6.3 Operation rules:

Forced cooling mode:

The indoor fan runs as breeze. After running for 30 minutes, AC will turn to auto mode with 24°C setting temperature.

Forced auto mode:

The action of forced auto mode is the same as normal auto mode with 24°C setting temperature.

6.4.6.4 When there's indoor unit running in forced cooling, it is the master forced cooling unit. Other indoor units will run at forced cooling mode too and they will be the slave forced cooling units. The slave forced cooling units can not quit forced cooling mode until the master forced cooling unit quit, and turn to cooling mode at low speed with 24°C setting temperature.

6.4.6.5 The slave forced cooling units will not be controlled by other signals except timer off signal.

For model MSR11-07HRDN1-Q& MSR11-09HRDN1-Q, the slave forced cooling units will not be controlled by other signals.

6.4.6.6 If AC is running in sleep mode and receives forced operation signal, it will quit the sleep mode.

6.4.7 Timer function

6.4.7.1 Timing range is 24 hours.

6.4.7.2 Timer on. The machine will turn on automatically when reaching the setting time.

6.4.7.3 Timer off. The machine will turn off automatically when reaching the setting time.

6.4.7.4 Timer on/off. The machine will turn on automatically when reaching the setting “on” time, and then turn off automatically when reaching the setting “off” time.

6.4.7.5 Timer off/on. The machine will turn off automatically when reaching the setting “off” time, and then turn on automatically when reaching the setting “on” time.

6.4.7.6 The timer function will not change the AC current operation mode. Suppose AC is off now, it will not start up firstly after setting the “timer off” function. And when reaching the setting time, the timer LED will be off and the AC running mode has not been changed.

6.4.7.7 The setting time is relative time.

6.4.8 Sleep function mode

6.4.8.1 Operation time in sleep mode is 7 hours. After 7 hours the AC quits this mode and turns off.

6.4.8.2. Operation process in sleep mode is as follow:

When cooling, the setting temperature rises 1°C (be lower than 30°C) every one hour, 2 hours later the setting temperature stops rising and indoor fan is fixed as low speed.

When heating, the setting temperature decreases 1°C (be higher than 17°C) every one hour, 2 hours later the setting temperature stops rising and indoor fan is fixed as low speed. (Anti-cold wind function has the priority)

6.4.8.3 Timer off and remote controller off signals have the priority compared with sleep function.

6.4.8.4 When user uses timer off function in sleep mode (or sleep function in timer off mode), if the timing is less than 7 hours, sleep function will be cancelled when reaching the setting time. If the timing is more than 7 hours, the machine will not stop until reaches the setting time in sleep mode.

6.4.9 Auto-Restart function

The indoor unit is equipped with auto-restart function, which is carried out through an auto-restart module. In case of a sudden power failure, the module memorizes the setting conditions before the power failure. The unit will resume the previous operation setting (not including Swing function) automatically after 3 minutes when power returns.

If the memorization condition is forced cooling mode, the unit will run in cooling mode for 30 minutes

and turn to auto mode as 24°C setting temp.

6.4.11 Mode conflict

The indoor units can not work cooling mode and heating at same time.

Heating mode has a priority.

6.4.11.1 Definition:

	Cooling mode	Heating Mode	Fan	Off
Cooling mode	No	Yes	No	No
Heating Mode	Yes	No	Yes	No
Fan	No	Yes	No	No
Off	No	No	No	No

No: No mode conflict;

Yes: Mode conflict

6.4.11.2 Unit action

- Suppose Indoor unit A working in cooling mode or fan mode, and indoor unit B is set to heating mode, then A will change to off and B will work in heating mode.
- Suppose Indoor unit A working in heating mode, and indoor unit B is set to cooling mode or fan mode, then B will change to stand by and A will be no change.