



Engineered for flexibility and performance.™

MAC - 2004

Air Cooled Mini Chiller

Models: MAC/M4AC 040-058A/AR
MAC 075-125B/BR

M4AC 040-058AE/ARE
M4AC 075-125BE/BRE



McQuay[®]
Air Conditioning

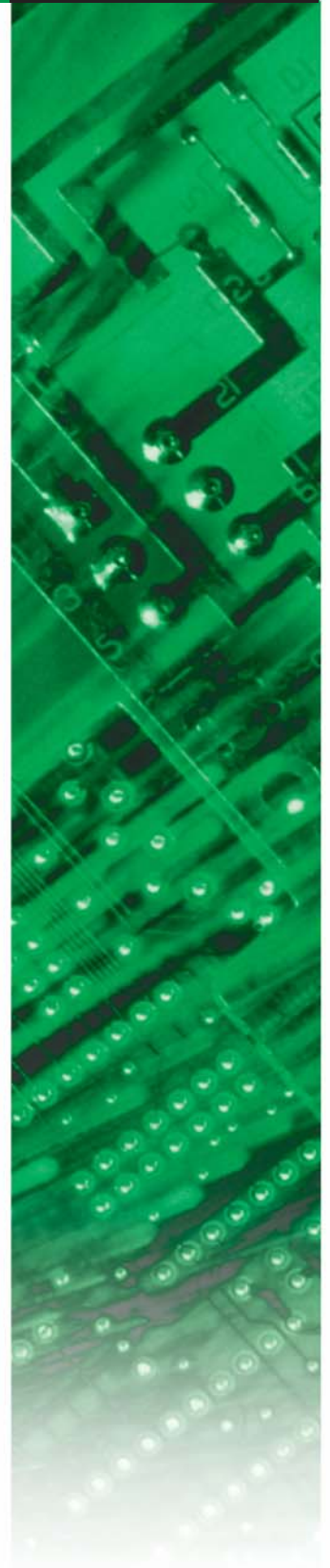

Contents

Nomenclature System.....	2
Features	2
General Specification.....	3
Specifications	9
Performance Characteristics.....	19
Technical Data	31
Outlines and Dimensions.....	32
Wiring Diagrams.....	35
Special Precautions for R407C.....	41
Installation	43
Servicing and Maintenance	46
Troubleshooting	47
Troubleshooting with Microprocessor	48
Schematic Diagram	49
Parts List and Exploded View.....	54

Note: Installation and maintenance are to be performed only by qualified personnel who are familiar with local codes and regulations, and experienced with this type of equipment,
Caution: Sharp edges and coil surfaces are a potential injury hazard. Avoid contact with them.

Warning: Moving machinery and electrical power hazards. May cause severe personal injury or death. Disconnect and lock off power before servicing equipment.

"McQuay" is a registered trademark of McQuay International. All rights reserved throughout the world.

©2003 McQuay International

"Bulletin illustrations cover the general appearance of McQuay International products at the time of publication and we reserve the right to make changes in design and construction at any time without notice."

Nomenclature System

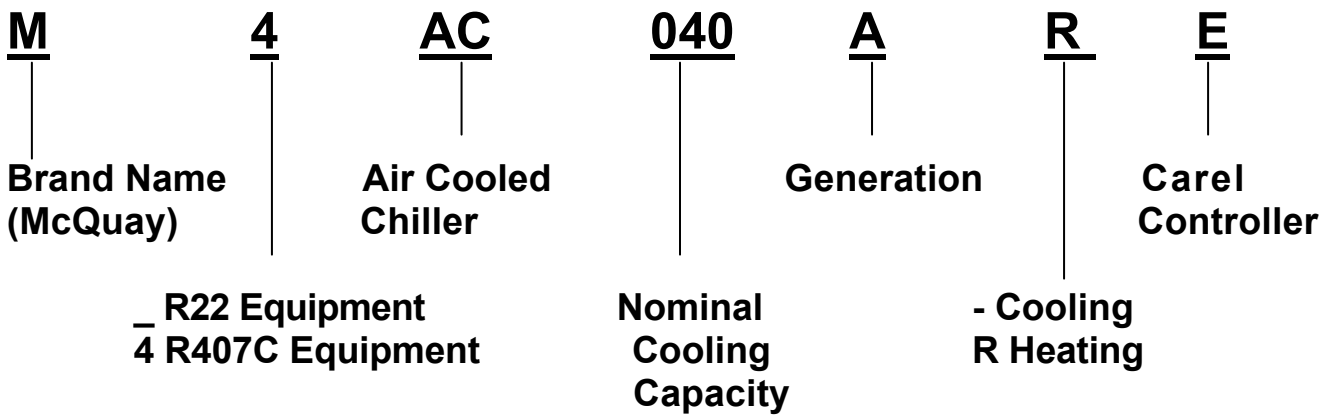

Features

General

The MCQUAY Mini Air Cooled Chillers have been designed to satisfy the most demanding reliability, safety and flexibility required by our customers. The new slim and compact design is available in six sizes, capacity range of 30,000 Btu/h to 125,000 Btu/h.

These mini chillers are constructed with two compartments, refrigeration circuit in the top compartment and chilled water circuit in the bottom compartment.

For environmentally friendly purposes, refrigerant is accurately charged in the factory by using sophisticated charging machine. All units are functionally tested to ensure optimum operating efficiency and excellent performance.

At job site, installation technician/engineer only needs to connect the water piping. Refrigerant pipe work is not necessary.

Capacity Versatility

These mini chillers can be coupled with different types of fan coil units for different application.

All Weather Cabinet

The cabinet is made of electro galvanized mild steel sheet, bonderized and coated with baked polyester powder paint to ensure the units durability in all climate.

Water Circuit Kit

The bottom compartment supplied as standard with the unit to facilitate and reduce the design and installation times. The compartment has been carefully designed and sized to optimize operating efficiency. The major component in the water circuit kit includes :

For MAC075/100/125 B/BR

- Water pump
- Insulated water storage tank
- Auto air vent
- Expansion tank
- PCB controller with thermo-sensor

For MAC040/050/058 A/AR

- Water pump
- Insulated water storage tank
- Brazed plate heat exchanger
- Flow switch

General Specifications

Air-Cooler Condenser

The air cooled condenser coil is consist of staggered rows of 3/8" OD seamless copper tube, mechanically expanded onto die formed aluminum fins to ensure optimum heat exchange capability.

Condenser Fan Motor

To achieve the high air change requirement, the unit is equip with the high air flow propeller fan which is made of acryl styrene resin. The fan is direct driven by weather proof single phase motor to ensure reliable continuos operation.

Evaporator

The heat exchanger is made of stainless steel plates closely arranged and brazed together to ensure high heat exchange efficiency. The complete heat exchanger is insulated with thermal closed cell nitric rubber foam to give optimum thermal insulation.

Refrigerant Circuit

The refrigerant circuit is factory brazed and evacuated before accurately charged with R22 to ensure optimum operating requirement. To ensure flawless continuous operation, each refrigerant circuit is equipped with a carefully sized thermostatic expansion valve and both thermostatic expansion valve and capillary tube in the heat pump model.

Additional Safety Proctection

The units are equipped with intelligently designed safety control to ensure continuous safe operation. High and low pressure switch is provided in cooling models to prevent the compressor damage resulting from both abnormally high discharge head pressure or low pressure due to insufficient gas. The heat pump models are provided with a high pressure switch.

The compressors of the whole range are provided with crank case heater to prevent liquid migration during the off cycle and also to ease the start up of the unit.

The standard electronic controller provides accurate water temperature control in the circuit by closely monitoring and reacting to the input from the water entering temperature, water leaving temperature and ambient air temperature.

Flow switch is provided in the unit to protect against damage to the water pump.

During abnormal condition the electronic controller will turn the unit off and the then display the faulty of operation. (See **Troubleshooting** sheet)

Antifreeze Protection

The antifreeze heater is activated if the water leaving temperature falls below 2°C (without glycol) in order to prevent heat exchanger from freezing up.

	Standard Factory Setting Entering Water Temp. °C	Min Entering	Max. Entering
Cooling Mode	12	3	15
Heating Mode	40	35	50
Antifreeze	3	- 4	3

Electronic Controller Setting

The temperature setting in the unit is preset in factory. It is recommended to observe and adjust the setting before commissioning the unit.

The following steps are to adjust the setting temperature :

- For cooling mode, press the SW1 button switch once in the PCB (see table below).
- The green LED will blink for few seconds.
- Adjusting the small variable resistor VR3 to the required water entering temperature by using a suitable tool.
- If glycol added for low temperature operation, the entering water temperature (3°C to 9°C) can be set by adjusting the DIP switch (SW2).
- For heating mode, press SW1 button switch twice and then the red LED will blink for a few seconds.
- Adjust the variable resistor (VR1) to set the required water entering temperature for heating mode.
- Press the SW1 three time to monitor the antifreeze temperature.
- Variable resistor VR2 is adjusted to set the antifreeze temperature in order to prevent the water freezing in the system.

SW2 Settings (For Cool Mode)

SET TEMP. °C	SW2		
	SW2-3	SW2-2	SW2-1
Set by VR3 (fixed)	off	off	off
3	off	off	on
4	off	on	off
5	off	on	on
6	on	off	off
7	on	off	on
8	on	on	off
9	on	on	on

If DIP switch is set to (off, off, off), the set temperature is determine by VR3 setting, otherwise setting above will override the VR3 setting.

Note : (Factory standard setting is recommended. If glycol added, the entering water temperature can be set by adjusting DIP switch SW2)

Microprocessor (For Carel Controller Only)

Compact µchiller is a versatile electronic controller as compact as a standard thermostat.

M4AC040AE/ARE, M4AC050AE/ARE, M4AC058AE/ARE, M4AC075BE/BRE, M4AC100BE/BRE, M4AC125BE/BRE Only

Main Functions

- Control of water temperature at evaporator inlet (inlet water)
- Time-based and/or temperature-based defrosting cycles
- Control of fan speed
- Full alarm management
- Can be linked up to serial line for supervisory telemaintenance control
- Can be linked up to an external terminal unit

Controlled Devices

- Compressor
- Condensation fans
- Reverse cycle valve
- Water pump
- Antifreeze heaters
- Alarm signaling device

User Interface

Display - The display consists of 3 digits, with the automatic display of the decimal point between -19.9 and + 19.9°C; outside this measurement range, the value is automatically displayed without decimal (although in its inside the machine is always operating by taking into account the decimal part). During the normal operation, the displayed value corresponds to the temperature being read by the probe B1, that is the evaporator water in-let temperature.

Status of the unit - The User is informed of the status of the unit by means of four LEDs on the display.

Meaning of LEDs in single-compressor units

LED	Flashing	Steady
Comp	Request for compressor	Compressor actuated
Cooling	-	Cooling
Heating	-	Heating
X100	-	Visualized value x 100

Alarms and Signaling

Any time an alarm condition is detected, the controller will prompt the following actions:

- the buzzer sounds
- the alarm relay energizes
- the temperature value blinks on display
- the alarm code appears on the LCD alternatively with the temperature value

After the alarms have been cleared either with automatic reset or by pressing the and buttons simultaneously for 5 seconds (for alarms with manual reset), the controller will restore normal operating conditions:

- the buzzer turns off
- the alarm relay disenergizes
- the temperature value blinks no longer
- the alarm code disappears from the LCD

If the alarm condition persists, the actions described above will be performed again.

Alarm Table

Display	Type	Comp.	pump	fan	Resist.	valve	alarm
H1	high pressure	OFF	-	ON	-	-	ON
L1	low pressure	OFF	-	OFF	-	-	ON
t1	overload	OFF	OFF	OFF	-	-	ON
FL	flow detector	OFF	OFF	OFF	-	-	ON
E1, E2, E3	probe	OFF	OFF	OFF	-	-	ON
n1	automatic timer	-	-	-	-	-	-
EE	eeprom run	-	-	-	-	-	-
EL	zero crossing	-	-	-	-	-	ON
d1	defrosting ON	-	-	-	-	-	-
r1	defrosting error	-	-	-	-	-	-
A1	antifreeze	OFF	-	OFF	-	-	ON
LO	low ambient temperature	-	-	-	-	-	ON
EU	low supply voltage	-	-	-	-	-	-
EO	high supply voltage	OFF	OFF	OFF	OFF	OFF	OFF
EP	eeprom boot	OFF	OFF	OFF	OFF	OFF	OFF
Cn	discon. Remote terminal	-	-	-	-	-	-
Ht	high temperature	-	-	-	-	-	ON

Electrical features

Power supply	
Voltage supply range	24V -15%...+10% 50/60Hz (20,4V~26,4Vac)
Maximum power absorbed by the device	3W
Characteristics of the fuse (obligatory) to be inserted in series to the unit power supply	315mA
Power driving	
Max. current for each power connector	2A
Relay output current (each relay, resistive load)	2A 250 V~
Relay output current (maximum 1 relay, resistive load)	3A 250 V~
Switching maximum number (each relay)	7000
Switching maximum time (each relay)	10 s

Buttons and Relative Messages on Display

Setting and displaying the set point and the main control parameters (DIRECT parameters).

The DIRECT parameters are set-points (Cooling and Heating) and main control parameters of the unit (Cooling and Heating differentials, water temperature, condensation temperature/pressure). If you press SEL for more than 5 seconds the display shows the code of the first parameter – the Cooling set-point- that can be modified. Pressing the ▲ and ▼ buttons allows to scroll all direct parameters. Press SEL again to display the required DIRECT parameter and modify its value (with the ▲ and ▼ buttons). Press PRG to store the modified parameters and exit the procedure, while the SEL button allows to return to the DIRECT parameters menu. On setting the parameters, the display will automatically flash after a few seconds if no buttons are pressed. If you do not press any button within 60 seconds after having entered this procedure, the unit will return to normal operation without storing the values of the modified parameters.

Setting and displaying USER parameters

These “working” parameters are protected by a password (22) to prevent any unauthorized access to the data. Press PRG for more than 5 seconds (the buzzer must be off) to enter the USER parameters (the unit “operating” parameters) menu and buttons ▲ and ▼ to select the password value, or, if the password is correct (22), press SEL to enter the USER parameter section. On setting the password, the display will automatically flash after a few seconds if no buttons are pressed. USER parameters selection: the display

shows the code of the USER parameter that can be modified. Pressing the ▲ and ▼ buttons allows to scroll all USER parameters. Press SEL again to display the required USER parameters and modify its value (with the ▲ and ▼ buttons). Press PRG to store the modified parameters and exit the procedure, while the SEL button allows to return to the USER parameters menu.

Setting and Displaying FACTORY-SET Parameters

Factory-set parameters are configuration parameters and so they are protected by a password (177) to prevent any unauthorized access to the data. Press PRG and SEL simultaneously for more than 5 seconds to enter the factory-set parameters (unit configuration parameters) menu. This section is protected by a code (password), which is different from the USER one, to prevent any unauthorized access to the data. Setting the password: "00" flashes on the display. Pressing the ▲ and ▼ buttons will allow you to stop the blinking effect for a few seconds and select the password value (177); then press SEL to directly enter the factory-set parameters section. On setting the password, the display will automatically flash after a few seconds if no buttons are pressed. FACTORY set parameters selection: the display shows the code of the factory-set parameter that can be modified. Pressing ▲ and ▼ allows to scroll all FACTORY-set parameters. Press SEL again to display the required FACTORY parameter and modify its value (with the ▲ and ▼ buttons). Press PRG to store the modified parameters and exit the procedure, while the SEL button allows to return to the FACTORY parameters menu.

Muting the Buzzer

Press the MUTE button to silence the buzzer.

Resetting ALARMS

Press ▲ and ▼ for more than 5 seconds to reset any alarm condition (manual reset). The relative LED light will turn off and the alarm relay will disenergize.

Forcing a DEFROSTING Cycle

To force a defrosting cycle press the SEL and buttons ▲ for more than 5 seconds (if the temperature/pressure values of the outdoor exchanger are lower than the values set for the end of defrosting).

Enabling/Disabling of COOLING Operating Mode

The cooling operating mode can be enabled/disabled by pressing the button ▲ for more than 5 seconds. It is not possible to directly pass from the heating to the cooling operating mode if before the heating mode is not unprimed: if the unit is actually operating in the heating mode, pressing the button will not swap the mode.

Enabling/Disabling of HEATING Operating Mode

The heating operating mode can be enabled/disabled by pressing the button ▼ for more than 5 seconds. It is not possible to directly pass from the Cooling mode to the Heating operating mode: It is necessary to inhibit the Cooling mode.

Stand-by

To turn off the unit, deactivate the current operating mode (Cooling or Heating). When the µchiller is turned off, it keeps the 4-way valves in the previous position for a period equal to pump OFF delay after the compressor is OFF.

Reset Timers

When the display shows the operating hours of the compressor or of the pump, you can reset the timer by pressing the ▲ and ▼ buttons. In this case the unit will not prompt the relative compressors maintenance message.

Copying the KEY in the Unit's eeprom

Press PRG and ▲ at µchiller start-up to copy the removable hardware key into the eeprom of the unit. When the procedure is over, the display will show 'CE' to confirm the operation.

Copying the Unit's eeprom in the Key

Press PRG and ▼ at µchiller start-up to copy the unit's eeprom into the removable hardware key. When the procedure is over, the display will show 'EC' to confirm the operation.

Setting DEFAULT PARAMETERS

Press the PRG button at μ chiller start-up to set default parameters. Default parameters are based on FACTORY-set parameters and refer to DIRECT and USER parameters only. When the procedure is over, the display will show dF to confirm the operation.

Button	Status of the unit	Effect after pressing the button
SEL	Normal operating condition (display shows the temperature of sensor B1) List of codes	After 5" DIRECT parameters appear Displays value
PRG	Normal operating condition List of codes Displays values Buzzer sound	After 5" password for USER parameters Stores parameters in eeprom Stores parameters in eeprom Silences the buzzer
▲	Normal operating condition List of codes Displays values	After 5" enables/inhibits Cooling mode Displays the codes of the parameters Increase values
▼	Normal operating condition List of codes Displays values	After 5" enables/inhibits Heating mode Displays the codes of the parameters Decrease values
PRG + SEL	Normal operating condition	After 5" password for FACTORY parameters
SEL + ▲	Normal operating condition	After 5" forces a manual defrosting cycle
▲ + ▼	Normal operating condition Hour counter is shown	After 5" manual alarm reset hour counter zeroes down immediately
PRG	At start up	Default parameters
PRG + ▲	At start up	Copies key on the unit's eeprom
PRG + ▼	At start up	Copies unit's eeprom on the key

Specifications

Air Cooled Mini Chiller

MODEL		MAC040A	MAC050A	MAC058A	
NOMINAL COOLING CAPACITY	Btu/hr	30,000	40,000	50,000	
	kcal/hr	7,560	10,080	12,600	
	Watt	8,790	11,720	14,650	
CASING	MATERIAL	Electro-galvanised Mild Steel			
	FINISH	Polyester Powder			
	THICKNESS	mm	1		
TOTAL UNIT DIMENSION	HEIGHT (H)	mm (in)	1,342 (52.8)		
	WIDTH (W)	mm (in)	1,032 (40.6)		
	DEPTH (D)	mm (in)	558 (22.0)		
TOTAL WEIGHT	kg	150	155	160	
NOISE LEVEL	dB-A	58	58	71	
EVAPORATOR					
TYPE		Braze Plate Heat Exchanger			
PLATE MATERIAL		Stainless Steel			
WATER VOLUME	m ³	0.00075	0.001	0.0014	
NOMINAL WATER FLOW	l/s	0.42	0.56	0.70	
BPHE PRESSURE DROP VS NOMINAL FLOW RATE	kPa	41.00	37.20	37.10	
UNIT PRESSURE DROP VS NOMINAL FLOW RATE	kPa	42.11	39.32	39.80	
WATER LINE (HYDRAULIC KIT)					
PUMP	TYPE	Horizontal Multistage End-Suction			
	POWER SUPPLY	V/Ph/Hz	380 - 420 / 3 / 50		
	RUNNING CURRENT	Amp	1.02	1.02	1.05
	WATER FLOW RATE	GPM (l/s)	6.66 (0.421)	8.89 (0.561)	11.10 (0.700)
PIPING	INSTALLATION PIPE CONNECTION	mm (in)	42mmBSP (1 1/4")		
	HEAD	m	24	22	20
TANK	MATERIAL	Black Mild Steel			
	CAPACITY/ VOLUME	litres	32		
CONDENSER COIL					
TYPE		Cross Finned Tubes			
TUBE	MATERIAL	Seamless Copper			
	WALL THICKNESS	mm (in)	0.35 (0.014)		
	OUTER DIAMETER	mm (in)	9.52 (3/8)		
FIN	MATERIAL	Aluminium			
	THICKNESS	mm (in)	0.127 (0.0005)		
	ROWS		2	2	2
	FIN PER INCH		14	16	16
FACE AREA	m ² (ft ²)	0.87 (9.36)			
CONDENSER FAN					
TYPE/DRIVE		Propeller/Direct			
QUANTITY		1			
BLADE MATERIAL		Acryl Styrene Resin			
BLADE DIAMETER	mm (in)	609.6 (24)			
POWER SUPPLY	V/Ph/Hz	220 - 240 / 1 / 50			
RATED RUNNING CURRENT	Amp	1.09	1.09	1.8	
RATED INPUT	Watt	241	241	420	
RATED OUTPUT	Watt	145	145	400	
MOTOR POLES		8	8	6	
AIR VOLUME	cmm/cfm	99 / 3,500		127 / 4,500	
COMPRESSOR					
TYPE		Recip.	Recip.	Scroll	
POWER SUPPLY	V/Ph/Hz	380 - 420 / 3 / 50			
RATED RUNNING CURRENT	Amp	5.34	7.11	8.29	
RATED INPUT	Watt	2,983	4,343	4,681	
MAXIMUM STARTING CURRENT	Amp	45	62	74	
PROTECTION DEVICES	Overload Protection, Flow Switch and H/L Pressure Switch				
STAGE OF CAPACITY CONTROL	On/Off				
REFRIGERANT					
TYPE		R22			
CONTROL		Thermostatic Expansion Valve			
CHARGING MASS	kg	3.10	3.00	2.90	

Notes:

- 1) All specifications are subjected to change by manufacturer without prior notice.
- 2) Nominal values are based on entering / leaving chilled water temperature 12°C / 7°C and air ambient temperature 35°C.

Air Cooled Reverse Cycle Mini Chiller

MODEL			MAC040AR	MAC050AR	MAC058AR
NOMINAL COOLING CAPACITY	Btu/hr		30,000	40,000	48,000
	kcal/hr		7,560	10,080	12,100
	Watt		8,790	11,720	14,060
NOMINAL HEATING CAPACITY	Btu/hr		32,000	43,000	50,000
	kcal/hr		8,060	10,840	12,600
	Watt		9,380	12,600	14,650
CASING	MATERIAL	Electro-galvanised Mild Steel			
	FINISH	Polyester Powder			
	THICKNESS	mm	1		
TOTAL UNIT DIMENSION	HEIGHT (H)	mm (in)	1,342 (52.8)		
	WIDTH (W)	mm (in)	1,032 (40.6)		
	DEPTH (D)	mm (in)	558 (22.0)		
TOTAL WEIGHT		kg	150	155	160
NOISE LEVEL		dB-A	58	58	71
EVAPORATOR					
TYPE		Braze Plate Heat Exchanger			
PLATE MATERIAL		Stainless Steel			
WATER VOLUME	m ³	0.00075	0.00100	0.00140	
NOMINAL WATER FLOW	l/s	0.42	0.56	0.70	
BPHE PRESSURE DROP VS NOMINAL FLOW RATE	kPa	41.00	37.20	37.10	
UNIT PRESSURE DROP VS NOMINAL FLOW RATE	kPa	42.11	39.32	39.80	
WATER LINE (HYDRAULIC KIT)					
PUMP	TYPE	Horizontal Multistage End-Suction			
	POWER SUPPLY	V/Ph/Hz	380 - 420 / 3 / 50		
	RUNNING CURRENT	Amp	1.02	1.02	1.05
	WATER FLOW RATE	GPM (l/s)	6.66 (0.421)	8.89 (0.561)	11.10 (0.7)
PIPING	INSTALLATION PIPE CONNECTION	mm (in)	42mmBSP (1 1/4")		
	HEAD	m	24	22	20
TANK	MATERIAL	Black Mild Steel			
	CAPACITY/ VOLUME	litres	32		
CONDENSER COIL					
TYPE		Cross Finned Tubes			
TUBE	MATERIAL	Seamless Copper			
	WALL THICKNESS	mm (in)	0.35 (0.014)		
	OUTER DIAMETER	mm (in)	9.52 (3/8)		
FIN	MATERIAL	Aluminium			
	THICKNESS	mm (in)	0.127 (0.0005)		
	ROWS		2	2	2
	FIN PER INCH		14	16	16
FACE AREA	m ² (ft ²)	0.87 (9.36)			
CONDENSER FAN					
TYPE/DRIVE		Propeller/Direct			
QUANTITY		1			
BLADE MATERIAL		Acryl Styrene Resin			
BLADE DIAMETER	mm (in)	609.6 (24)			
POWER SUPPLY	V/Ph/Hz	220 - 240 / 1 / 50			
RATED RUNNING CURRENT	Amp	1.09	1.09	1.80	
RATED INPUT	Watt	241	241	420	
RATED OUTPUT	Watt	145	145	400	
MOTOR POLES		8	8	6	
AIR VOLUME	cmm/cfm	99 / 3,500			127 / 4,500
COMPRESSOR					
TYPE		Recip.	Recip.	Scroll	
POWER SUPPLY	V/Ph/Hz	380 - 420 / 3 / 50			
RATED RUNNING CURRENT (COOLING)	Amp	5.52	7.50	7.90	
RATED RUNNING CURRENT (HEATING)	Amp	5.62	7.24	8.20	
RATED INPUT (COOLING)	Watt	3,212	4,373	4,341	
RATED INPUT (HEATING)	Watt	3,187	4,084	4,656	
MAXIMUM STARTING CURRENT	Amp	45	62	74	
PROTECTION DEVICES	Overload Protection, Flow Switch and H/L Pressure Switch				
STAGE OF CAPACITY CONTROL	On/Off				
REFRIGERANT					
TYPE		R22			
CONTROL		Thermostatic Expansion Valve			
CHARGING MASS	kg	2.10	2.38	2.50	

Notes :

- 1) All specifications are subjected to change by manufacturer without prior notice.
- 2) Nominal values are based on entering / leaving chilled water temperature 12°C / 7°C and air ambient temperature 35°C.
- 3) Nominal values are based on entering / leaving hot water temperature 40°C / 45°C and air ambient temperature 7°C.

Air Cooled Mini Chiller

MODEL			MAC075B	MAC100B	MAC125B
NOMINAL COOLING CAPACITY		Btu/hr	80,000	100,000	125,000
		kcal/hr	20,160	25,200	31,500
		Watt	23,440	29,300	36,630
CASING	MATERIAL		Electro-galvanised Mild Steel		
	FINISH		Polyester Powder		
	THICKNESS	mm	1.5		
TOTAL UNIT DIMENSION	HEIGHT (H)	mm (in)	1,739 (68.5)		
	WIDTH (W)	mm (in)	1,089 (42.9)		
	DEPTH (D)	mm (in)	1,288 (50.7)		
WEIGHT		kg	350	365	380
NOISE LEVEL		dB-A	65	65	74
CONDENSER COIL					
TYPE		Cross Finned Tubes			
TUBE	MATERIAL		Seamless Copper		
	WALL THICKNESS	mm (in)	0.35 (0.014)		
	OUTER DIAMETER	mm (in)	9.52 (3/8)		
FIN	MATERIAL		Aluminium		
	THICKNESS	mm (in)	0.127 (0.0005)		
	ROWS		2		
	FIN PER INCH		16		
TOTAL FACE AREA		m ² (ft ²)	2.95 (31.75)		
EVAPORATOR					
TYPE		Brazen Plate Heat Exchanger			
PLATE MATERIAL		Stainless Steel			
WATER VOLUME		m ³	0.00143	0.00190	0.00300
NOMINAL WATER FLOW		l/s	1.12	1.40	1.75
BPHE PRESSURE DROP VS NOMINAL FLOW RATE		kPa	37.00	38.00	34.95
UNIT PRESSURE DROP VS NOMINAL FLOW RATE		kPa	41.21	44.63	46.00
CONDENSER FAN					
TYPE/DRIVE		Propeller/Direct			
QUANTITY		1			
BLADE MATERIAL		Aluminium			
BLADE DIAMETER		mm (in)	660.4 (26)	660.4 (26)	762 (30)
POWER SUPPLY		V/Ph/Hz	380 - 415 / 3 / 50		
RATED RUNNING CURRENT		Amp	1.4	1.4	3.6
RATED INPUT		Watt	640	640	1,978
RATED OUTPUT		Watt	588	588	1,250
MOTOR POLES			6	6	6
AIR VOLUME		cmm/cfm	176 / 6,200	176 / 6,200	297 / 10,500
WATER LINE (HYDRAULIC KIT)					
PUMP	TYPE		Horizontal Multistage End-Suction		
	RUNNING CURRENT	Amp	1.5	1.5	1.5
	WATER FLOW RATE	GPM (l/s)	17.78 (1.122)	22.22 (1.402)	27.75 (1.751)
PIPING	INSTALLATION PIPE CONNECTION		42mmBSP (1 1/4")		
	HEAD	m	27	23	18
TANK	MATERIAL		Black Mild Steel		
	CAPACITY/ VOLUME	litres	150		
COMPRESSOR					
TYPE		Scroll			
POWER SUPPLY		V/Ph/Hz	380 - 415 / 3 / 50		
RATED RUNNING CURRENT		Amp	14.7	15.3	23
RATED INPUT		Watt	7,700	9,010	13,220
MAXIMUM STARTING CURRENT		Amp	125	167	198
PROTECTION DEVICES		Overload Protection, Flow Switch and H/L Pressure Switch			
STAGE OF CAPACITY CONTROL		On/Off			
REFRIGERANT					
TYPE		R22			
CONTROL		Thermostatic Expansion Valve			
CHARGING MASS		kg	5.50	5.50	7.40

Notes :

- 1) All specifications are subjected to change by manufacturer without prior notice.
- 2) Nominal values are based on entering / leaving chilled water temperature 12°C / 7°C and air ambient temperature 35°C.

Air Cooled Reverse Cycle Mini Chiller

MODEL		MAC075BR	MAC100BR	MAC125BR	
NOMINAL COOLING CAPACITY	Btu/hr	80,000	94,000	125,000	
	kcal/hr	20,160	23,690	31,500	
	Watt	23,440	27,540	36,630	
NOMINAL HEATING CAPACITY	Btu/hr	93,000	100,000	145,000	
	kcal/hr	23,440	25,200	36,540	
	Watt	27,250	29,300	42,490	
CASING	MATERIAL	Electro-galvanised Mild Steel			
	FINISH	Polyester Powder			
	THICKNESS	mm	1.5		
TOTAL UNIT DIMENSION	HEIGHT (H)	mm (in)	1,739 (68.5)		
	WIDTH (W)	mm (in)	1,089 (42.9)		
	DEPTH (D)	mm (in)	1,288 (50.7)		
WEIGHT		kg	350	365	380
NOISE LEVEL		dB-A	65	65	74
CONDENSER COIL					
TYPE		Cross Finned Tubes			
TUBE	MATERIAL	Seamless Copper			
	WALL THICKNESS	mm (in)	0.35 (0.014)		
	OUTER DIAMETER	mm (in)	9.52 (3/8)		
FIN	MATERIAL	Aluminium			
	THICKNESS	mm (in)	0.127 (0.0005)		
	ROWS		2		
	FIN PER INCH		16		
TOTAL FACE AREA		m ² (ft ²)	2.95 (31.75)		
EVAPORATOR					
TYPE		Brazed Plate Heat Exchanger			
PLATE MATERIAL		Stainless Steel			
WATER VOLUME		m ³	0.00143	0.00190	0.00300
NOMINAL WATER FLOW		l/s	1.12	1.40	1.75
BPHE PRESSURE DROP VS NOMINAL FLOW RATE		kPa	37.00	38.00	34.95
UNIT PRESSURE DROP VS NOMINAL FLOW RATE		kPa	41.21	44.63	46.00
CONDENSER FAN					
TYPE/DRIVE		Propeller/Direct			
QUANTITY		1			
BLADE MATERIAL		Aluminium			
BLADE DIAMETER		mm (in)	660.4 (26)	660.4 (26)	762 (30)
POWER SUPPLY		V/Ph/Hz			
RATED RUNNING CURRENT		Amp	1.4	1.4	3.6
RATED INPUT		Watt	640	640	1,978
RATED OUTPUT		Watt	588	588	1,250
MOTOR POLES			6	6	6
AIR VOLUME		cmm/cfm	176 / 6,200	176 / 6,200	297 / 10,500
WATER LINE (HYDRAULIC KIT)					
PUMP	TYPE	Horizontal Multistage End-Suction			
	RUNNING CURRENT	Amp	1.5	1.5	1.5
	WATER FLOW RATE	GPM (l/s)	17.78 (1.122)	22.22 (1.402)	27.75 (1.751)
PIPING	INSTALLATION PIPE CONNECTION	mm (in)	42mmBSP (1 1/4")		
	HEAD	m	27	23	18
TANK	MATERIAL	Black Mild Steel			
	CAPACITY/ VOLUME	litres	150		
COMPRESSOR					
TYPE		Scroll			
POWER SUPPLY		V/Ph/Hz			
RATED RUNNING CURRENT		Amp	15.6	17.5	22.0
	HEATING	Amp	15.7	17.2	23.3
RATED INPUT		Watt	8,200	9,410	12,832
	HEATING	Watt	8,500	9,174	13,882
MAXIMUM STARTING CURRENT		Amp	125	167	198
PROTECTION DEVICES		Overload Protection, Flow Switch and H/L Pressure Switch			
STAGE OF CAPACITY CONTROL		On/Off			
REFRIGERANT					
TYPE		R22			
CONTROL		Thermostatic Expansion Valve			
CHARGING MASS		kg	7.90	7.90	8.60

Notes :

- 1) All specifications are subjected to change by manufacturer without prior notice.
- 2) Nominal values are based on entering / leaving chilled water temperature 12°C / 7°C and air ambient temperature 35°C.
- 3) Nominal values are based on entering / leaving hot water temperature 40°C / 45°C and air ambient temperature 7°C.

Air Cooled Mini Chiller (R407C)

MODEL		M4AC040A	M4AC050A	M4AC058A
NOMINAL COOLING CAPACITY	Btu/hr	30,000	40,000	48,000
	kcal/hr	7,560	10,080	12,100
	Watt	8,792	11,723	14,068
CASING	MATERIAL	Electro-galvanised Mild Steel		
	FINISH	Polyester Powder		
	THICKNESS	mm	1	
TOTAL UNIT DIMENSION	HEIGHT (H)	mm (in)	1,342 (52.8)	
	WIDTH (W)	mm (in)	1,032 (40.6)	
	DEPTH (D)	mm (in)	558 (22.0)	
TOTAL WEIGHT	kg	150	155	160
NOISE LEVEL	dB-A	58	58	71
EVAPORATOR				
TYPE		Brazen Plate Heat Exchanger		
PLATE MATERIAL		Stainless Steel		
WATER VOLUME	m ³	0.00075	0.001	0.0014
NOMINAL WATER FLOW	l/s	0.42	0.56	0.70
BPHE PRESSURE DROP VS NOMINAL FLOW RATE	kPa	41.00	37.20	37.10
UNIT PRESSURE DROP VS NOMINAL FLOW RATE	kPa	42.11	39.32	39.80
WATER LINE (HYDRAULIC KIT)				
PUMP	TYPE	Horizontal Multistage End-Suction		
	POWER SUPPLY	V/Ph/Hz	380 - 420 / 3 / 50	
	RUNNING CURRENT	Amp	1.02	1.02
WATER FLOW RATE	GPM (l/s)	6.78 (0.427)	8.89 (0.561)	11.10 (0.700)
PIPING	INSTALLATION PIPE CONNECTION	mm (in)	42mmBSP (1 1/4")	
	HEAD	m	24	22
TANK	MATERIAL	Black Mild Steel		
	CAPACITY/ VOLUME	litres	32	
CONDENSER COIL				
TYPE		Cross Finned Tubes		
TUBE	MATERIAL	Seamless Copper		
	WALL THICKNESS	mm (in)	0.35 (0.014)	
	OUTER DIAMETER	mm (in)	9.52 (3/8)	
FIN	MATERIAL	Aluminium		
	THICKNESS	mm (in)	0.127 (0.0005)	
	ROWS		2	2
	FIN PER INCH		14	16
FACE AREA	m ² (ft ²)	0.87 (9.36)		
CONDENSER FAN				
TYPE/DRIVE		Propeller/Direct		
QUANTITY		1		
BLADE MATERIAL		Acryl Styrene Resin		
BLADE DIAMETER	mm (in)	609.6 (24)		
POWER SUPPLY	V/Ph/Hz	220 - 240 / 1 / 50		
RATED RUNNING CURRENT	Amp	1.09	1.09	2.8
RATED INPUT	Watt	241	241	655
RATED OUTPUT	Watt	145	145	400
MOTOR POLES		8	8	6
AIR VOLUME	cmm/cfm	99 / 3,500		136 / 4,800
COMPRESSOR				
TYPE		Scroll		
POWER SUPPLY	V/Ph/Hz	380 - 420 / 3 / 50		
RATED RUNNING CURRENT	Amp	5.85	8.31	8.28
RATED INPUT	Watt	3,180	4,270	4,690
MAXIMUM STARTING CURRENT	Amp	49.3	65.5	74
PROTECTION DEVICES		Overload Protection, Flow Switch and H/L Pressure Switch		
STAGE OF CAPACITY CONTROL		On/Off		
REFRIGERANT				
TYPE		R407C		
CONTROL		Thermostatic Expansion Valve		
CHARGING MASS	kg	2.25	2.75	2.60

Notes :

- 1) All specifications are subjected to change by manufacturer without prior notice.
- 2) Nominal values are based on entering / leaving chilled water temperature 12°C / 7°C and air ambient temperature 35°C.

Air Cooled Reverse Cycle Mini Chiller (R407C)

MODEL		M4AC040AR	M4AC050AR	M4AC058AR	
NOMINAL COOLING CAPACITY	Btu/hr	30,000	40,000	48,000	
	kcal/hr	7,560	10,080	12,120	
	Watt	8,790	11,720	14,060	
NOMINAL HEATING CAPACITY	Btu/hr	33,000	43,000	50,000	
	kcal/hr	8,320	10,840	12,600	
	Watt	9,670	12,600	14,650	
CASING	MATERIAL	Electro-galvanised Mild Steel			
	FINISH	Polyester Powder			
	THICKNESS	mm	1		
TOTAL UNIT DIMENSION	HEIGHT (H)	mm (in)	1,342 (52.8)		
	WIDTH (W)	mm (in)	1,032 (40.6)		
	DEPTH (D)	mm (in)	558 (22.0)		
TOTAL WEIGHT	kg	150	155	160	
NOISE LEVEL	dB-A	58	58	71	
EVAPORATOR					
TYPE		Braze Plate Heat Exchanger			
PLATE MATERIAL		Stainless Steel			
WATER VOLUME	m ³	0.00075	0.00100	0.00140	
NOMINAL WATER FLOW	l/s	0.42	0.56	0.70	
BPHE PRESSURE DROP VS NOMINAL FLOW RATE	kPa	41.00	37.20	37.10	
UNIT PRESSURE DROP VS NOMINAL FLOW RATE	kPa	42.11	39.32	39.80	
WATER LINE (HYDRAULIC KIT)					
PUMP	TYPE		Horizontal Multistage End-Suction		
	POWER SUPPLY	V/Ph/Hz	380 - 420 / 3 / 50		
	RUNNING CURRENT	Amp	1.02	1.02	1.05
	WATER FLOW RATE	GPM (l/s)	6.78 (0.427)	8.89 (0.561)	11.10 (0.700)
PIPING	INSTALLATION PIPE CONNECTION		42mmBSP (1 1/4")		
	HEAD	m	24	22	20
TANK	MATERIAL		Black Mild Steel		
	CAPACITY/ VOLUME	litres	32		
CONDENSER COIL					
TYPE		Cross Finned Tubes			
TUBE	MATERIAL		Seamless Copper		
	WALL THICKNESS	mm (in)	0.35 (0.014)		
	OUTER DIAMETER	mm (in)	9.52 (3/8)		
FIN	MATERIAL		Aluminium		
	THICKNESS	mm (in)	0.127 (0.0005)		
	ROWS		2	2	2
	FIN PER INCH		16	16	16
FACE AREA	m ² (ft ²)	0.87 (9.36)			
CONDENSER FAN					
TYPE/DRIVE		Propeller / Direct			
QUANTITY		1			
BLADE MATERIAL		Acryl Styrene Resin			
BLADE DIAMETER	mm (in)	609.6 (24)			
POWER SUPPLY	V/Ph/Hz	220 - 240 / 1 / 50			
RATED RUNNING CURRENT	Amp	1.09	1.09	2.8	
RATED INPUT	Watt	241	241	655	
RATED OUTPUT	Watt	145	145	400	
MOTOR POLES		8	8	6	
AIR VOLUME	cmm/cfm	99 / 3,500		136 / 4,800	
COMPRESSOR					
TYPE		Scroll			
POWER SUPPLY	V/Ph/Hz	380 - 420 / 3 / 50			
RATED RUNNING CURRENT (COOLING)	Amp	5.61	8.11	8.28	
RATED RUNNING CURRENT (HEATING)	Amp	6.32	8.67	8.61	
RATED INPUT (COOLING)	Watt	3,050	4,070	4,690	
RATED INPUT (HEATING)	Watt	3,600	4,610	5,210	
MAXIMUM STARTING CURRENT	Amp	49.3	65.5	74	
PROTECTION DEVICES		Overload Protection, Flow Switch and H/L Pressure Switch			
STAGE OF CAPACITY CONTROL		On/Off			
REFRIGERANT					
TYPE		R407C			
CONTROL		Thermostatic Expansion Valve			
CHARGING MASS	kg	2.35	2.55	2.60	

Notes :

- 1) All specifications are subjected to change by manufacturer without prior notice.
- 2) Nominal values are based on entering / leaving chilled water temperature 12°C / 7°C and air ambient temperature 35°C.
- 3) Nominal values are based on entering / leaving hot water temperature 40°C / 45°C and air ambient temperature 7°C.

Air Cooled Chiller

MODEL		M4AC040AE	M4AC050AE	M4AC058AE	
NOMINAL COOLING CAPACITY	Btu/hr	30,000	40,000	48,000	
	kcal/hr	7,560	10,080	12,100	
	Watt	8,792	11,723	12,068	
CASING	MATERIAL	Electro-galvanised Mild Steel			
	FINISH	Polyester Powder			
TOTAL UNIT DIMENSION	THICKNESS	mm	1		
	HEIGHT (H)	mm (in)	1,342 (52.8)		
	WIDTH (W)	mm (in)	1,032 (40.6)		
	DEPTH (D)	mm (in)	558 (22.0)		
TOTAL WEIGHT		kg	150	155	160
NOISE LEVEL		dB-A	58	58	71
EVAPORATOR					
TYPE		Braze Plate Heat Exchanger			
PLATE MATERIAL		Stainless Steel			
WATER VOLUME		m ³	0.00075	0.001	0.0014
NOMINAL WATER FLOW		l/s	0.42	0.56	0.70
BPHE PRESSURE DROP VS NOMINAL FLOW RATE		kPa	41.00	37.20	37.10
UNIT PRESSURE DROP VS NOMINAL FLOW RATE		kPa	42.11	39.32	39.80
WATER LINE (HYDRAULIC KIT)					
PUMP	TYPE		Horizontal Multistage End-Suction		
	POWER SUPPLY	V/Ph/Hz	380 - 420 / 3 / 50		
	RUNNING CURRENT	Amp	1.02	1.02	1.05
PIPING	WATER FLOW RATE	GPM (l/s)	6.78 (0.427)	8.89 (0.561)	11.10 (0.700)
	INSTALLATION PIPE CONNECTION	mm (in)	42mmBSP (1 1/4")		
	HEAD	m	24	22	20
TANK	MATERIAL		Black Mild Steel		
	CAPACITY/ VOLUME	litres	32		
CONDENSER COIL					
TYPE		Cross Fined Tubes			
TUBE	MATERIAL		Seamless Copper		
	WALL THICKNESS	mm (in)	0.35 (0.014)		
	OUTER DIAMETER	mm (in)	9.52 (3/8)		
FIN	MATERIAL		Aluminium		
	THICKNESS	mm (in)	0.127 (0.0005)		
	ROWS		2	2	2
	FIN PER INCH		14	16	16
FACE AREA		m ² (ft ²)	0.87 (9.36)		
CONDENSER FAN					
TYPE/DRIVE		Propeller/Direct			
QUANTITY		1			
BLADE MATERIAL		Acryl Styrene Resin			
BLADE DIAMETER		mm (in)	609.6 (24)		
POWER SUPPLY		V/Ph/Hz	220 - 240 / 1 / 50		
RATED RUNNING CURRENT		Amp	1.09	1.09	2.8
RATED INPUT		Watt	241	241	655
RATED OUTPUT		Watt	145	145	400
MOTOR POLES			8	8	6
AIR VOLUME		L/s / cfm	1652 / 3500		2124 / 4500
COMPRESSOR					
TYPE		Scroll			
POWER SUPPLY		V/Ph/Hz	380 - 420 / 3 / 50		
RATED RUNNING CURRENT		Amp	5.85	8.42	8.12
RATED INPUT		Watt	3,180	4,310	4,740
MAXIMUM STARTING CURRENT		Amp	49.3	65.5	74
PROTECTION DEVICES		Overload Protection, Differential Pressure and H/L Pressure Switch			
STAGE OF CAPACITY CONTROL		On/Off			
REFRIGERANT					
TYPE		R407C			
CONTROL		Thermostatic Expansion Valve			
CHARGING MASS		kg	2.25	2.75	2.60

Notes :

- 1) All specifications are subjected to change by manufacturer without prior notice.
- 2) Nominal values are based on entering / leaving chilled water temperature 12°C / 7°C and air ambient temperature 35°C.

Air Cooled Chiller

MODEL		M4AC075BE	M4AC100BE	M4AC125BE	
NOMINAL COOLING CAPACITY	btu/hr	76000	95000	118750	
	kcal/hr	19152	23940	29925	
	watt	22268	27835	34793	
CASING	MATERIAL	Electro-galvanized Mild Steel			
	FINISH	Polyester Powder			
	THICKNESS	mm	1.5		
DIMENSION	HEIGHT (H)	mm	1739(1036*)		
	WIDTH (W)	mm	1089(1010*)		
	DEPTH (D)	mm	1288(1187*)		
WEIGHT	kg	350	365	380	
NOISE LEVEL	db-A	67	67	69	
CONDENSER COIL					
TYPE		Cross Finned Tubes			
TUBE	MATERIAL	Seamless Copper			
	WALL THICKNESS	mm	0.35		
	OUTER DIAMETER	mm	9.52		
FIN	MATERIAL	Aluminium			
	THICKNESS	mm	0.127		
	ROWS		2	2	2
	FIN PER INCH		16		
TOTAL FACE AREA	m ²	2.95	2.95	2.95	
EVAPORATOR					
TYPE		Brazed Plate Heat Exchanger			
PLATE MATERIAL		Stainless Steel			
WATER VOLUME	m ³	0.00143	0.0019	0.003	
NOMINAL WATER FLOW	l/s	1.12	1.40	1.75	
CONDENSER FAN					
TYPE/DRIVE		Propeller/Direct			
QUANTITY		1			
BLADE MATERIAL		Aluminium			
BLADE DIAMETER	INCHI	30			
POWER SUPPLY	v/ph/Hz	220/1/50			
RATED RUNNING CURRENT	Amp	3.4	3.4	3.4	
RATED INPUT	watt	900	900	900	
RATED OUTPUT	watt	555	555	555	
MOTOR POLES		8			
WATER LINE (HYDRAULIC KIT)					
PUMP	TYPE		Horizontal Multistage End-Suction		
	MAX. WATER OPER. PRESSURE	kPa	1000		
	RUNNING CURRENT	Amp	1.7	1.7	1.7
PIPING	WATER FLOW RATE	Gpm(l/s)	17.78(1.122)	22.22(1.402)	27.75(1.751)
	INSTALLATION PIPE CONNECTION	mm(in)	42mmBSP(1 ¹ / ₄ "		
	HEAD	m	27	23	18
TANK	MATERIAL	BLACK STEEL			
	CAPACITY/VOLUME	litres	150		
COMPRESSOR					
TYPE		SCROLL			
POWER SUPPLY	v/ph/Hz	380~415/3/50			
RATED RUNNING CURRENT	Amp	14.7	18.5	22.8	
RATED INPUT	watt	7750	10060	13300	
MAXIMUM STARTING CURRENT	Amp	125	167	198	
PROTECTION DEVICES		Overload Protection, Differential Pressure and H/L Pressure Switch			
STAGE OF CAPACITY CONTROL		ON/OFF			
REFRIGERANT					
TYPE		R407C			
CONTROL		Thermostatic Expansion Valve			
CHARGING MASS	kg	5.00	6.55	7.40	

Note : Nominal values are based on 12°C / 7°C entering / leaving evaporator water temperature 35°C air ambient temperature.

* : Unit dimension without hydraulic kit.

Air Cooled Chiller

MODEL		M4AC040ARE	M4AC050ARE	M4AC058ARE
NOMINAL CAPACITY (COOLING/HEATING)	Btu/hr	30000/33000	40000/43000	48000/50000
	kcal/hr	7560/8316	10080/10836	12100/12600
	Watt	8792/9669	11723/12600	12068/14650
CASING	MATERIAL	Electro-galvanised Mild Steel		
	FINISH	Polyester Powder		
	THICKNESS	1 mm		
TOTAL UNIT DIMENSION	HEIGHT (H)	1,342 (52.8) mm (in)		
	WIDTH (W)	1,032 (40.6) mm (in)		
	DEPTH (D)	558 (22.0) mm (in)		
TOTAL WEIGHT	kg	150	155	160
NOISE LEVEL	dB-A	58	58	71
EVAPORATOR				
TYPE		Braze Plate Heat Exchanger		
PLATE MATERIAL		Stainless Steel		
WATER VOLUME	m ³	0.00075	0.001	0.0014
NOMINAL WATER FLOW	l/s	0.42	0.56	0.70
BPHE PRESSURE DROP VS NOMINAL FLOW RATE	kPa	41.00	37.20	37.10
UNIT PRESSURE DROP VS NOMINAL FLOW RATE	kPa	42.11	39.32	39.80
WATER LINE (HYDRAULIC KIT)				
PUMP	TYPE	Horizontal Multistage End-Suction		
	POWER SUPPLY	380 - 420 / 3 / 50 V/Ph/Hz		
	RUNNING CURRENT	Amp	1.02	1.05
	WATER FLOW RATE	GPM (l/s)	6.78 (0.427)	8.89 (0.561)
PIPING	INSTALLATION PIPE CONNECTION	42mmBSP (1 1/4") mm (in)		
	HEAD	m	24	20
TANK	MATERIAL	Black Mild Steel		
	CAPACITY/ VOLUME	litres	32	
CONDENSER COIL				
TYPE		Cross Finned Tubes		
TUBE	MATERIAL	Seamless Copper		
	WALL THICKNESS	mm (in)	0.35 (0.014)	
	OUTER DIAMETER	mm (in)	9.52 (3/8)	
FIN	MATERIAL	Aluminium		
	THICKNESS	mm (in)	0.127 (0.0005)	
	ROWS		2	2
	FIN PER INCH		14	16
FACE AREA	m ² (ft ²)	0.87 (9.36)		
CONDENSER FAN				
TYPE/DRIVE		Propeller/Direct		
QUANTITY		1		
BLADE MATERIAL		Acryl Styrene Resin		
BLADE DIAMETER	mm (in)	609.6 (24)		
POWER SUPPLY	V/Ph/Hz	220 - 240 / 1 / 50		
RATED RUNNING CURRENT	Amp	1.09	1.09	2.8
RATED INPUT	Watt	241	241	655
RATED OUTPUT	Watt	145	145	400
MOTOR POLES		8	8	6
AIR VOLUME	L/s / cfm	1652 / 3500		2124 / 4500
COMPRESSOR				
TYPE		Scroll		
POWER SUPPLY	V/Ph/Hz	380 - 420 / 3 / 50		
RATED RUNNING CURRENT	Amp	5.85	8.42	8.12
RATED INPUT	Watt	3,180	4,310	4,740
MAXIMUM STARTING CURRENT	Amp	49.3	65.5	74
PROTECTION DEVICES		Overload Protection, Differential Pressure and H/L Pressure Switch		
STAGE OF CAPACITY CONTROL		On/Off		
REFRIGERANT				
TYPE		R407C		
CONTROL		Thermostatic Expansion Valve		
CHARGING MASS	kg	2.35	2.55	2.60

Notes :

- 1) All specifications are subjected to change by manufacturer without prior notice.
- 2) Nominal values are based on entering / leaving chilled water temperature 12°C / 7°C and air ambient temperature 35°C.
- 3) Nominal values are based on entering / leaving chilled water temperature 40°C / 45°C and air ambient temperature 7°C.

Air Cooled Chiller

MODEL		M4AC075BRE	M4AC100BRE	M4AC125BRE	
NOMINAL CAPACITY (COOLING / HEATING)	btu/hr	68240/71652	85300/95536	105772/114302	
	kcal/hr	17197/18057	21496/24076	26656/28810	
	watt	20000/21000	25000/28000	31000/33500	
CASING	MATERIAL	Electro-galvanized Mild Steel			
	FINISH	Polyester Powder			
	THICKNESS	mm	1.5		
DIMENSION	HEIGHT (H)	mm	1739(1036*)		
	WIDTH (W)	mm	1089(1010*)		
	DEPTH (D)	mm	1288(1187*)		
WEIGHT	kg	350	365	380	
NOISE LEVEL	db-A	67	67	69	
CONDENSER COIL					
TYPE		Cross Finned Tubes			
TUBE	MATERIAL	Seamless Copper			
	WALL THICKNESS	mm	0.35		
	OUTER DIAMETER	mm	9.52		
FIN	MATERIAL	Aluminium			
	THICKNESS	mm	0.127		
	ROWS		2	2	2
	FIN PER INCH		16		
TOTAL FACE AREA	m ²	2.95	2.95	2.95	
EVAPORATOR					
TYPE		Brazen Plate Heat Exchanger			
PLATE MATERIAL		Stainless Steel			
WATER VOLUME	m ³	0.00143	0.0019	0.003	
NOMINAL WATER FLOW	l/s	1.00	1.20	1.50	
CONDENSER FAN					
TYPE/DRIVE		Propeller/Direct			
QUANTITY		1			
BLADE MATERIAL		Aluminium			
BLADE DIAMETER	INCHI	30			
POWER SUPPLY	v/ph/Hz	220/1/50			
RATED RUNNING CURRENT	Amp	3.4	3.4	3.4	
RATED INPUT (COOLING / HEATING)	watt	900	900	900	
RATED OUTPUT (COOLING / HEATING)	watt	555	555	555	
MOTOR POLES		8			
WATER LINE (HYDRAULIC KIT)					
PUMP	TYPE		Horizontal Multistage End-Suction		
	MAX. WATER OPER. PRESSURE	kPa	1000		
	RUNNING CURRENT	Amp	1.7	1.7	1.7
	WATER FLOW RATE	Gpm(l/s)	15.85(1.0)	19.02(1.2)	23.78(1.5)
PIPING	INSTALLATION PIPE CONNECTION	mm(in)	42mmBSP(1 ¹ / ₄ "		
	HEAD	m	27	23	18
TANK	MATERIAL	BLACK STEEL			
	CAPACITY/VOLUME	litres	150		
COMPRESSOR					
TYPE		SCROLL			
POWER SUPPLY	v/ph/Hz	380~415/3/50			
RATED CURRENT (COOLING / HEATING)	Amp	16.1/16.3	18.7/17.9	24/22.4	
RATED INPUT (COOLING / HEATING)	watt	8500/8700	9500/8800	14900/12800	
MAXIMUM STARTING CURRENT	Amp	125	167	198	
PROTECTION DEVICES		Overload Protection, Differential and H/L Pressure Switch			
STAGE OF CAPACITY CONTROL		ON/OFF			
REFRIGERANT					
TYPE		R407C			
CONTROL		Thermostatic Expansion Valve			
CHARGING MASS	kg	7.80	10.50	10.50	

Note : Nominal values are based on 12°C / 7°C entering / leaving evaporator water temperature , 35°C air ambient temperature.

Note : Nominal values are based on 40°C / 45°C entering / leaving evaporator water temperature , 7°C air ambient temperature.

Note: Unit dimension without hydraulic kit.

Performance Characteristics

Cooling Version

MODEL	LEAVING WATER TEMPERATURES(°C)	AMBIENT TEMPERATURE ON CONDENSER (°C)													
		19		28		32		35		40		42		46	
		COOL CAP. KW	POWER INPUT KW	COOL CAP. KW	POWER INPUT KW	COOL CAP. KW	POWER INPUT KW	COOL CAP. KW	POWER INPUT KW	COOL CAP. KW	POWER INPUT KW	COOL CAP. KW	POWER INPUT KW	COOL CAP. KW	POWER INPUT KW
MAC040A	5	10.42	2.67	9.79	2.85	8.92	3.03	7.98	3.15	7.45	3.28	6.76	3.53	6.02	3.75
	6	10.62	2.79	10.23	2.98	9.28	3.14	8.41	3.27	7.80	3.45	7.03	3.65	6.42	3.84
	7	11.05	2.88	10.55	3.07	9.72	3.27	8.79	3.41	8.14	3.60	7.33	3.78	6.97	3.97
	8	11.45	2.96	10.94	3.19	10.06	3.40	9.80	3.54	8.52	3.72	7.50	3.86	7.24	4.12
	9	11.78	3.05	11.29	3.28	11.24	3.53	10.12	3.66	8.87	3.81	7.65	3.98	7.41	4.25
	10	12.15	3.17	11.63	3.41	11.67	3.62	10.51	3.74	9.24	3.92	7.97	4.12	7.68	4.33
MAC050A	5	11.73	3.75	10.57	3.95	9.82	4.12	9.26	4.27	8.33	4.35	7.95	4.41	7.45	4.51
	6	13.21	3.79	12.26	3.99	11.27	4.14	10.50	4.30	9.30	4.42	8.78	4.50	8.08	4.63
	7	14.18	3.84	13.84	4.01	12.63	4.20	11.72	4.34	10.23	4.57	9.64	4.67	8.82	4.78
	8	15.22	3.89	14.52	4.05	14.00	4.25	12.97	4.36	11.37	4.61	10.48	4.79	9.57	4.90
	9	16.07	3.95	15.50	4.07	15.14	4.31	14.00	4.38	12.34	4.72	11.24	4.88	10.48	4.98
	10	17.00	4.00	16.36	4.13	16.08	4.38	15.07	4.41	13.23	4.87	12.13	5.01	11.10	5.12
MAC058A	5	13.18	3.89	12.54	3.99	11.92	4.14	11.28	4.32	10.97	4.66	10.53	4.80	10.03	4.89
	6	14.45	3.98	14.04	4.03	12.55	4.27	12.25	4.50	12.08	4.90	12.00	5.01	11.75	5.04
	7	16.10	4.01	15.23	4.07	14.91	4.42	14.65	4.68	14.23	5.11	13.81	5.29	13.30	5.38
	8	17.22	4.09	16.57	4.18	16.25	4.58	15.39	4.86	14.99	5.30	14.54	5.62	14.00	5.67
	9	18.67	4.23	18.21	4.30	17.05	4.78	16.16	5.04	15.69	5.57	15.20	5.79	14.85	5.88
	10	21.02	4.41	19.38	4.49	17.90	4.93	17.34	5.22	16.47	5.90	16.21	6.10	15.35	6.31

Cooling Heat Pump Version

MODEL	LEAVING WATER TEMPERATURE (°C)	AMBIENT TEMPERATURE ON CONDENSER (°C)													
		19		28		32		35		40		42		46	
		COOL CAP. KW	POWER INPUT KW	COOL CAP. KW	POWER INPUT KW	COOL CAP. KW	POWER INPUT KW	COOL CAP. KW	POWER INPUT KW	COOL CAP. KW	POWER INPUT KW	COOL CAP. KW	POWER INPUT KW	COOL CAP. KW	POWER INPUT KW
MAC040AR	5	9.40	2.26	8.90	2.41	8.76	2.54	8.50	2.87	8.32	3.09	8.20	3.27	7.94	3.47
	6	9.78	2.30	9.16	2.43	8.83	2.71	8.70	3.03	8.43	3.24	8.31	3.45	8.07	3.65
	7	10.19	2.37	9.43	2.47	8.97	2.83	8.79	3.18	8.55	3.41	8.45	3.58	8.23	3.73
	8	10.48	2.42	9.70	2.51	9.10	2.95	8.98	3.31	8.62	3.55	8.51	3.69	8.36	3.85
	9	11.02	2.46	10.05	2.53	9.44	3.04	9.15	3.47	8.74	3.63	8.63	3.81	8.48	3.99
	10	11.54	2.53	10.71	2.57	10.02	3.17	9.43	3.61	8.83	3.78	8.69	3.95	8.57	4.12
MAC050AR	5	11.03	3.70	10.64	3.92	10.03	4.11	9.23	4.23	8.37	4.36	8.06	4.40	8.00	4.52
	6	12.73	3.77	12.22	3.97	11.42	4.15	10.50	4.31	9.34	4.44	8.90	4.47	8.58	4.69
	7	14.28	3.85	13.73	4.02	12.58	4.19	11.72	4.34	10.34	4.59	9.74	4.65	9.17	4.78
	8	15.09	3.92	14.42	4.07	14.10	4.23	12.99	4.38	11.66	4.70	10.53	4.79	9.88	4.90
	9	16.17	4.00	15.32	4.12	15.06	4.28	13.94	4.41	12.47	4.82	11.17	4.88	10.21	5.04
	10	17.23	4.03	16.33	4.14	16.02	4.31	15.05	4.45	13.73	4.95	12.33	4.99	11.05	5.13
MAC058AR	5	13.01	3.79	12.22	3.89	12.08	3.98	11.93	4.14	11.82	4.59	11.69	4.72	11.21	5.00
	6	14.05	3.83	13.18	4.03	13.02	4.17	12.85	4.32	12.75	4.77	12.64	4.97	11.93	5.21
	7	15.24	3.88	14.37	4.12	14.19	4.35	14.06	4.47	13.85	4.95	13.78	5.14	12.74	5.40
	8	16.37	3.96	15.52	4.38	15.37	4.56	15.25	4.73	15.03	5.13	14.70	5.30	13.90	5.61
	9	17.54	4.04	16.45	4.57	16.37	4.81	16.28	5.02	16.17	5.32	15.77	5.52	14.82	5.78
	10	18.48	4.12	17.54	4.78	17.39	5.03	17.15	5.21	16.99	5.58	16.64	5.74	15.75	5.92

Heating Heat Pump Version

MODEL	LEAVIGN WATER TEMPERATURE(°C)	AMBIENT TEMPERATURE ON CONDENSER (°C)															
		-7		-5		0		4		7		10		15		20	
		HEAT CAP. kW	POWER INPUT kW	HEAT CAP. kW	POWER INPUT kW	HEAT CAP. kW	POWER INPUT kW	HEAT CAP. kW	POWER INPUT kW	HEAT CAP. kW	POWER INPUT kW	HEAT CAP. kW	POWER INPUT kW	HEAT CAP. kW	POWER INPUT kW	HEAT CAP. kW	POWER INPUT kW
MAC040AR	35	6.87	2.25	7.36	2.40	7.81	2.58	9.44	2.72	10.16	2.84	10.66	3.09	11.58	3.30	12.40	3.52
	40	6.42	2.34	6.90	2.52	7.40	2.69	8.99	2.82	9.60	2.98	10.25	3.23	11.21	3.45	12.04	3.73
	45	6.0	2.46	6.53	2.63	7.07	2.80	8.50	2.94	9.38	3.09	9.90	3.37	10.68	3.58	11.53	3.87
	50					6.8	2.91	8.06	2.99	8.70	3.24	9.58	3.53	10.24	3.72	10.99	4.03
	55					6.52	3.01	7.52	3.13	8.27	3.45	9.25	3.69	9.64	3.93	10.54	4.44
MAC050AR	35	8.54	2.96	9.12	3.04	10.39	3.22	12.73	3.51	14.70	3.72	16.70	3.93	18.88	4.15	19.84	4.35
	40	7.62	3.08	8.13	3.17	9.18	3.43	11.40	3.67	13.61	3.89	15.52	4.11	17.93	4.34	18.76	4.60
	45	6.75	3.17	7.4	3.32	8.13	3.64	10.60	3.84	12.60	4.05	14.60	4.24	16.76	4.53	17.37	4.78
	50					7.38	3.85	9.75	3.99	11.53	4.19	13.68	4.41	15.91	4.67	16.42	4.92
	55					7.34	4.06	9.06	4.18	10.36	4.36	12.79	4.60	14.84	4.89	15.47	5.09
MAC058AR	35	11.01	3.43	12.28	3.52	13.74	3.67	15.50	3.81	16.96	3.88	18.10	4.00	19.87	4.11	21.02	4.78
	40	9.64	3.82	10.83	3.95	12.58	4.13	14.30	4.28	15.69	4.32	16.91	4.48	18.72	4.60	19.85	5.17
	45	7.88	4.07	9.09	4.48	11.45	4.63	13.16	4.76	14.65	4.85	15.73	4.94	17.87	5.09	18.40	5.68
	50					11.0	5.11	12.38	5.18	13.25	5.31	14.50	5.44	17.23	5.58	17.97	6.14
	55					10.15	5.59	11.29	5.62	12.14	5.78	13.31	5.91	16.58	6.07	17.08	6.29

Cooling Version

MODEL	LEAVING WATER TEMPERATURE (°C)	AMBIENT TEMPERATURE ON CONDENSER (°C)													
		19		28		32		35		40		42		46	
		COOL CAP. kW	POWER INPUT kW	COOL CAP. kW	POWER INPUT kW	COOL CAP. kW	POWER INPUT kW	COOL CAP. kW	POWER INPUT kW	COOL CAP. kW	POWER INPUT kW	COOL CAP. kW	POWER INPUT kW	COOL CAP. kW	POWER INPUT kW
MAC075B	5	23.60	4.63	22.78	5.21	21.55	5.47	21.11	5.92	19.79	6.88	19.05	7.15	17.60	7.69
	6	24.40	5.10	23.54	6.02	22.62	6.35	22.44	6.87	21.60	7.24	21.06	7.97	19.96	9.43
	7	25.16	5.74	24.28	6.69	23.71	7.20	23.44	7.70	22.56	8.32	22.28	8.62	21.72	9.79
	8	25.87	6.82	24.99	7.72	24.60	8.12	24.18	8.50	23.08	9.10	22.90	9.45	22.54	10.15
	9	27.27	7.81	26.01	8.85	25.45	9.25	25.04	9.55	23.76	10.11	23.33	10.52	22.95	11.34
	10	27.96	8.05	26.95	9.12	26.50	10.23	25.82	10.71	24.22	11.27	23.76	11.69	23.34	12.53
MAC100B	5	31.41	6.28	29.97	7.38	29.33	7.87	28.89	8.26	26.81	9.32	25.82	9.98	23.83	11.30
	6	33.31	6.88	30.88	8.23	29.80	8.83	29.09	9.16	27.03	10.01	26.22	10.59	24.60	11.57
	7	35.46	7.85	31.99	9.09	30.45	9.64	29.30	10.06	27.37	10.76	26.61	11.03	25.09	11.75
	8	37.22	8.30	32.92	9.87	31.01	10.57	29.50	10.96	27.65	11.58	27.12	11.68	26.06	11.88
	9	38.90	9.17	33.90	10.65	31.68	11.31	29.70	11.86	28.03	12.17	27.63	12.35	26.83	12.71
	10	41.41	9.87	35.11	11.42	32.31	12.11	29.90	12.76	28.52	13.00	27.98	13.31	26.90	13.93
MAC125B	5	42.58	9.49	38.46	11.04	36.63	11.73	35.06	12.34	32.96	13.10	32.36	13.72	30.38	14.96
	6	43.89	9.98	39.39	12.07	37.39	13.00	36.08	13.60	33.28	14.67	32.67	15.01	30.67	15.96
	7	45.00	10.94	40.30	13.12	38.21	14.09	36.62	14.82	34.00	16.03	32.95	16.51	30.93	17.47
	8	45.90	12.25	41.18	14.32	38.98	15.24	38.06	16.13	35.04	17.45	33.46	17.98	31.41	19.04
	9	46.35	12.92	42.10	15.17	40.34	16.17	39.25	17.28	36.12	18.91	34.10	19.20	32.0	19.78
	10	46.57	14.65	44.00	16.52	42.86	17.35	40.56	18.32	37.15	20.42	34.85	21.30	32.70	23.06

Cooling In Heat Pump Version

MODEL	LEAVIGN WATER TEMPERATURE(°C)	AMBIENT TEMPERATURE ON CONDENSER (°C)													
		19		28		32		35		40		42		46	
		COOL CAP. KW	POWER INPUT KW	COOL CAP. KW	POWER INPUT KW	COOL CAP. KW	POWER INPUT KW	COOL CAP. KW	POWER INPUT KW	COOL CAP. KW	POWER INPUT KW	COOL CAP. KW	POWER INPUT KW	COOL CAP. KW	POWER INPUT KW
MAC075BR	5	25.03	5.83	22.91	5.92	21.97	5.96	21.39	6.42	20.46	7.03	19.01	7.32	16.11	7.90
	6	25.53	6.10	23.67	6.37	22.80	6.72	22.62	7.28	21.73	7.75	21.36	8.24	20.62	9.22
	7	25.80	6.35	24.43	6.88	23.86	7.58	23.44	8.20	22.75	8.65	22.48	8.96	21.94	9.86
	8	26.37	7.11	25.22	7.94	24.71	8.31	24.37	9.15	23.67	9.47	23.20	9.99	22.26	11.03
	9	26.81	7.37	25.93	8.92	25.54	9.61	25.14	9.89	24.30	10.54	23.96	10.87	23.28	11.53
	10	27.20	7.97	26.66	9.75	26.42	10.54	25.99	10.98	25.17	11.48	24.42	11.91	23.73	12.77
MAC100BR	5	28.40	5.45	27.77	6.80	27.49	7.40	27.07	8.25	25.44	9.14	24.92	9.76	23.88	11.00
	6	31.22	6.00	29.06	7.60	28.10	8.31	27.30	9.02	25.92	10.02	25.23	10.47	24.17	11.37
	7	33.96	6.87	30.47	8.51	28.92	9.24	27.54	10.04	26.56	11.04	25.50	11.57	24.53	12.63
	8	35.88	7.74	31.47	9.34	29.51	10.05	28.81	10.94	27.13	11.85	26.05	12.46	25.06	13.68
	9	38.16	8.11	32.67	10.34	30.23	11.33	28.94	11.89	27.86	12.58	26.52	13.22	25.51	14.50
	10	40.97	9.43	34.08	11.14	31.02	11.90	29.68	12.53	28.38	13.29	27.16	14.00	26.40	15.42
MAC125BR	5	42.94	8.90	37.88	10.63	35.63	11.40	34.90	11.50	33.98	12.45	32.22	14.05	28.70	17.25
	6	43.97	10.50	38.95	11.66	36.72	11.97	35.60	12.50	34.34	13.74	33.12	14.88	30.68	18.16
	7	45.66	11.20	40.30	12.48	37.92	13.14	36.62	13.63	35.17	15.25	33.96	16.64	31.54	19.42
	8	46.72	12.32	42.42	13.38	40.00	13.85	39.02	14.85	36.36	16.51	34.60	18.26	32.13	21.76
	9	47.87	12.67	43.32	14.20	41.81	14.88	40.42	16.63	37.44	17.72	35.20	19.50	32.72	23.06
	10	48.29	14.11	44.94	15.30	43.45	15.83	41.78	17.48	38.56	18.98	35.89	20.58	33.55	23.78

Heating In Heat Pump Version

MODEL	LEAVING WATER TEMPERATURE(°C)	AMBIENT TEMPERATURE ON CONDENSER (°C)															
		-7		-5		0		4		7		10		15		20	
		HEAT CAP. kW	POWER INPUT kW	HEAT CAP. kW	POWER INPUT kW	HEAT CAP. kW	POWER INPUT kW	HEAT CAP. kW	POWER INPUT kW	HEAT CAP. kW	POWER INPUT kW	HEAT CAP. kW	POWER INPUT kW	HEAT CAP. kW	POWER INPUT kW	HEAT CAP. kW	POWER INPUT kW
MAC075BR	35	15.02	6.50	21.86	7.24	25.26	7.62	27.07	7.79	28.49	8.05	29.43	8.27	31.08	8.53	33.72	8.95
	40	12.30	7.21	20.17	7.65	24.13	7.85	25.97	8.05	27.89	8.27	28.57	8.57	30.37	8.79	33.20	9.14
	45	10.43	7.65	18.73	7.95	22.84	8.08	25.25	8.34	27.25	8.50	27.98	8.81	29.50	9.04	31.95	9.38
	50					21.27	8.31	24.36	8.57	26.68	8.82	27.35	9.07	28.77	9.51	30.19	10.22
	55					19.23	8.54	23.00	8.68	25.84	9.04	26.73	9.46	27.74	9.90	29.36	10.60
MAC100BR	35	17.55	7.08	23.86	7.64	27.01	7.92	28.75	8.02	31.04	8.37	31.99	8.78	33.03	9.21	34.69	9.90
	40	16.79	7.58	22.49	7.98	25.33	8.21	27.91	8.45	30.01	8.95	31.12	9.23	32.07	9.74	33.58	10.48
	45	14.01	8.06	21.07	8.52	24.62	8.75	27.15	9.01	29.30	9.27	30.07	9.68	31.04	10.43	32.42	11.43
	50					22.95	9.29	26.03	9.31	28.35	9.84	29.28	10.22	30.40	10.75	32.15	11.63
	55					21.67	9.83	25.00	9.95	27.50	10.35	28.43	10.83	29.45	11.15	31.08	11.66
MAC125BR	35	23.31	9.69	31.95	10.65	36.27	11.13	41.22	12.18	45.23	12.95	48.61	13.33	52.31	13.69	58.20	14.21
	40	21.95	9.80	30.14	11.23	34.28	12.00	39.78	12.75	43.85	13.41	47.45	13.92	51.27	14.21	57.40	14.68
	45	18.77	10.75	28.23	11.97	32.95	12.58	38.26	13.27	42.49	13.92	46.18	14.41	50.00	14.72	56.05	15.20
	50					32.23	13.16	37.42	13.91	41.67	14.41	45.33	14.72	48.45	14.97	53.44	15.41
	55					31.65	13.72	36.75	14.33	40.75	14.87	44.89	15.14	47.12	15.37	50.69	15.75

Cooling Version

MODEL		AMBIENT TEMPERATURE ON CONDENSER (°C)													
		19		28		32		35		40		42		46	
		COOL CAP. kW	POWER INPUT kW	COOL CAP. kW	POWER INPUT kW	COOL CAP. kW	POWER INPUT kW	COOL CAP. kW	POWER INPUT kW	COOL CAP. kW	POWER INPUT kW	COOL CAP. kW	POWER INPUT kW	COOL CAP. kW	POWER INPUT kW
M4AC040A M4AC040AE	5	10.11	2.86	9.50	3.05	8.65	3.24	7.74	3.37	7.23	3.51	6.56	3.78	5.84	4.01
	6	10.30	2.99	9.92	3.19	9.00	3.36	8.16	3.50	7.57	3.69	6.82	3.91	6.23	4.11
	7	10.72	3.08	10.23	3.28	9.43	3.50	8.53	3.65	7.90	3.85	7.05	4.04	6.76	4.25
	8	11.11	3.17	10.61	3.41	9.76	3.64	9.51	3.79	8.26	3.98	7.25	4.13	7.02	4.41
	9	11.43	3.26	10.95	3.51	10.90	3.78	9.82	3.92	8.60	4.08	7.42	4.26	7.19	4.55
	10	11.79	3.39	11.28	3.65	11.32	3.87	10.12	4.00	8.96	4.19	7.73	4.41	7.45	4.63
M4AC050A M4AC050AE	5	11.38	4.01	10.25	4.23	9.53	4.41	8.98	4.57	8.08	4.65	7.71	4.72	7.23	4.83
	6	12.81	4.06	11.89	4.27	10.93	4.43	10.19	4.60	9.02	4.73	8.52	4.82	7.84	4.95
	7	13.75	4.11	13.42	4.29	12.25	4.49	11.37	4.64	9.92	4.89	9.35	5.00	8.56	5.11
	8	14.76	4.16	14.08	4.33	13.58	4.55	12.58	4.67	11.03	4.93	10.17	5.13	9.28	5.24
	9	15.59	4.23	15.04	4.35	14.69	4.61	13.58	4.69	11.97	5.05	10.90	5.22	10.17	5.33
	10	16.49	4.28	15.87	4.42	15.60	4.69	14.62	4.72	12.83	5.21	11.77	5.36	10.77	5.48
M4AC058A M4AC058AE	5	12.78	4.16	12.16	4.27	11.56	4.43	10.94	4.62	10.64	4.99	10.21	5.14	9.73	5.23
	6	14.02	4.26	13.62	4.31	12.17	4.57	11.88	4.82	11.72	5.24	11.64	5.36	11.40	5.39
	7	15.62	4.47	14.77	4.35	14.46	4.73	14.21	5.01	13.80	5.47	13.40	5.66	12.90	5.76
	8	16.70	4.64	16.07	4.47	15.76	4.90	14.93	5.20	14.54	5.67	14.10	6.01	13.58	6.07
	9	18.11	4.86	17.66	4.60	16.54	5.11	15.68	5.39	15.22	5.96	14.74	6.20	14.40	6.29
	10	20.39	4.93	18.80	4.80	17.36	5.28	16.82	5.59	15.98	6.31	15.72	6.53	14.89	6.75

Cooling In Heat Pump Version

MODEL	LEAVING WATER TEMPERATURE (°C)	AMBIENT TEMPERATURE ON CONDENSER (°C)													
		19		28		32		35		40		42		46	
		COOL CAP. kW	POWER INPUT kW	COOL CAP. kW	POWER INPUT kW	COOL CAP. kW	POWER INPUT kW	COOL CAP. kW	POWER INPUT kW	COOL CAP. kW	POWER INPUT kW	COOL CAP. kW	POWER INPUT kW	COOL CAP. kW	POWER INPUT kW
M4AC040AR M4AC040ARE	5	9.12	2.42	8.63	2.58	8.50	2.72	8.38	3.07	8.07	3.31	7.95	3.50	7.70	3.71
	6	9.49	2.46	8.89	2.60	8.57	2.90	8.50	3.24	8.18	3.47	8.06	3.69	7.83	3.91
	7	9.88	2.54	9.15	2.64	8.70	3.03	8.53	3.40	8.29	3.65	8.20	3.83	7.98	3.99
	8	10.17	2.59	9.41	2.69	8.83	3.16	8.71	3.54	8.36	3.80	8.25	3.95	8.11	4.12
	9	10.69	2.63	9.75	2.71	9.16	3.25	8.88	3.71	8.48	3.88	8.37	4.08	8.23	4.27
	10	11.19	2.71	10.39	2.75	9.72	3.39	9.15	3.86	8.57	4.04	8.43	4.23	8.31	4.41
M4AC050AR M4AC050ARE	5	10.70	3.96	10.32	4.19	9.73	4.40	8.95	4.53	8.12	4.67	7.82	4.71	7.76	4.84
	6	12.35	4.03	11.85	4.25	11.08	4.44	10.19	4.61	9.06	4.75	8.63	4.78	8.32	5.02
	7	13.85	4.12	13.32	4.30	12.20	4.48	11.37	4.64	10.03	4.91	9.45	4.98	8.89	5.11
	8	14.64	4.19	13.99	4.35	13.68	4.53	12.60	4.69	11.31	5.03	10.21	5.13	9.58	5.24
	9	15.68	4.28	14.86	4.41	14.61	4.58	13.52	4.72	12.10	5.16	10.83	5.22	9.90	5.39
	10	16.71	4.31	15.84	4.43	15.54	4.61	14.60	4.76	13.32	5.30	11.96	5.34	10.72	5.49
M4AC058AR M4AC058ARE	5	12.62	4.06	11.85	4.16	11.72	4.26	11.57	4.43	11.47	4.91	11.34	5.05	10.87	5.35
	6	13.63	4.10	12.78	4.31	12.63	4.46	12.46	4.62	12.37	5.10	12.26	5.32	11.57	5.57
	7	14.78	4.15	13.94	4.41	13.76	4.65	13.64	4.78	13.43	5.30	13.37	5.50	12.36	5.78
	8	15.88	4.24	15.05	4.69	14.91	4.88	14.79	5.06	14.58	5.49	14.26	5.67	13.48	6.00
	9	17.01	4.32	15.96	4.89	15.88	5.15	15.79	5.37	15.68	5.69	15.30	5.91	14.38	6.18
	10	17.93	4.41	17.01	5.11	16.87	5.38	16.64	5.57	16.48	5.97	16.14	6.14	15.28	6.33

Heating In Heat Pump Version

MODEL	LEAVING WATER TEMPERATURE(°C)	AMBIENT TEMPERATURE ON CONDENSER (°C)															
		-7		-5		0		4		7		10		15		20	
		HEAT CAP. kW	POWER INPUT kW	HEAT CAP. kW	POWER INPUT kW	HEAT CAP. kW	POWER INPUT kW	HEAT CAP. kW	POWER INPUT kW	HEAT CAP. kW	POWER INPUT kW	HEAT CAP. kW	POWER INPUT kW	HEAT CAP. kW	POWER INPUT kW	HEAT CAP. kW	POWER INPUT kW
M4AC040AR M4AC040ARE	35	6.66	2.41	7.14	2.57	7.58	2.76	9.16	2.91	9.86	3.04	10.34	3.31	11.23	3.53	12.03	3.77
	40	6.23	2.50	6.69	2.70	7.18	2.88	8.72	3.02	9.31	3.19	9.94	3.46	10.87	3.69	11.68	3.99
	45	5.97	2.63	6.33	2.81	6.86	3.00	8.25	3.15	9.10	3.31	9.60	3.61	10.36	3.83	11.18	4.14
	50					6.69	3.11	7.82	3.20	8.44	3.47	9.29	3.78	9.93	3.98	10.66	4.31
	55					6.32	3.22	7.29	3.35	8.02	3.69	8.97	3.95	9.35	4.21	10.22	4.75
M4AC050AR M4AC050ARE	35	8.28	3.17	8.85	3.25	10.08	3.45	12.35	3.76	14.26	3.98	16.20	4.21	18.31	4.44	19.24	4.65
	40	7.39	3.30	7.89	3.39	8.90	3.67	11.06	3.93	13.20	4.16	15.05	4.40	17.39	4.64	18.20	4.92
	45	6.55	3.39	6.9	3.55	7.89	3.89	10.28	4.11	12.22	4.33	14.16	4.54	16.26	4.85	16.85	5.11
	50					7.16	4.12	9.46	4.27	11.18	4.48	13.27	4.72	15.43	5.00	15.93	5.26
	55					7.12	4.34	8.79	4.47	10.05	4.67	12.41	4.92	14.39	5.23	15.01	5.45
M4AC058AR M4AC058ARE	35	10.68	3.67	11.91	3.77	13.33	3.93	15.04	4.08	16.45	4.15	17.56	4.28	19.27	4.40	20.39	5.11
	40	9.35	4.09	10.51	4.23	12.20	4.77	13.87	4.58	15.22	4.62	16.40	4.79	18.16	4.92	19.25	5.53
	45	7.64	4.40	8.82	4.79	11.11	4.95	12.77	5.09	14.21	5.19	15.26	5.29	17.33	5.45	17.85	6.08
	50					10.88	5.47	12.01	5.54	12.85	5.68	14.07	5.82	16.71	5.97	17.43	6.57
	55					9.85	5.98	10.95	6.01	11.78	6.18	12.91	6.32	16.08	6.49	16.57	6.73

Cooling Version

MODEL		AMBIENT TEMPERATURE ON CONDENSER (°C)													
		19		28		32		35		40		42		46	
		COOL CAP. kW	POWER INPUT kW	COOL CAP. kW	POWER INPUT kW	COOL CAP. kW	POWER INPUT kW	COOL CAP. kW	POWER INPUT kW	COOL CAP. kW	POWER INPUT kW	COOL CAP. kW	POWER INPUT kW	COOL CAP. kW	POWER INPUT kW
M4AC075BE	5	22.92	4.95	22.10	5.57	20.90	5.85	20.48	6.33	19.20	7.36	18.48	7.65	17.07	8.23
	6	23.64	5.65	22.83	6.44	21.94	6.79	21.77	7.35	20.95	7.75	20.43	8.53	19.36	9.90
	7	24.47	5.93	23.55	7.16	23.00	7.70	22.74	8.24	21.88	8.90	21.61	9.22	21.07	10.50
	8	25.09	7.30	24.24	8.26	23.86	8.69	23.45	9.10	22.39	9.74	22.21	10.11	21.80	10.86
	9	26.45	8.51	25.23	9.47	24.69	9.90	24.29	10.22	23.05	10.82	22.63	11.26	22.00	12.13
	10	27.12	8.77	26.14	9.76	25.71	10.95	25.05	11.46	23.49	12.06	23.05	12.51	22.15	13.41
M4AC100BE	5	30.47	6.72	29.07	7.90	28.45	8.42	28.02	8.84	26.01	9.97	25.05	10.68	23.12	12.09
	6	32.31	7.36	29.95	8.81	28.91	9.45	28.22	9.80	26.22	10.71	25.43	11.33	23.86	12.38
	7	34.40	8.40	31.03	9.73	29.54	10.31	28.42	10.76	26.55	11.51	25.81	11.80	24.34	12.57
	8	36.10	8.88	31.93	10.56	30.08	11.31	28.62	11.73	26.82	12.39	26.31	12.50	25.28	12.71
	9	37.73	9.81	32.88	11.40	30.73	12.10	28.81	12.69	27.19	13.02	26.80	13.21	26.03	13.60
	10	40.17	10.56	34.06	12.22	31.34	12.96	29.00	13.65	27.66	13.91	27.14	14.24	26.29	14.91
M4AC125BE	5	41.30	10.15	37.31	11.81	35.53	12.55	34.01	13.20	31.60	14.02	31.39	14.68	29.47	16.01
	6	42.57	10.68	38.21	12.91	36.27	13.91	35.00	14.55	32.53	15.70	31.69	16.06	30.41	17.08
	7	43.65	11.71	39.09	14.04	37.06	15.08	35.52	15.86	32.98	17.15	31.96	17.67	30.75	18.69
	8	44.30	13.11	39.94	15.32	37.81	16.31	36.92	17.26	33.99	18.67	32.46	19.24	31.30	20.37
	9	44.90	13.82	40.84	16.23	39.13	17.30	38.07	18.49	35.04	20.23	33.08	20.54	31.85	21.16
	10	45.17	15.68	42.68	17.68	41.57	18.56	39.34	19.60	36.04	21.85	33.80	22.79	32.52	24.67

Cooling Heat Pump Version

MODEL		AMBIENT TEMPERATURE ON CONDENSER (°C)													
		19		28		32		35		40		42		46	
		COOL CAP. KW	POWER INPUT KW	COOL CAP. KW	POWER INPUT KW	COOL CAP. KW	POWER INPUT KW	COOL CAP. KW	POWER INPUT KW	COOL CAP. KW	POWER INPUT KW	COOL CAP. KW	POWER INPUT KW	COOL CAP. KW	POWER INPUT KW
M4AC075BRE	5	24.28	6.24	22.22	6.33	21.31	6.38	20.75	6.87	19.85	7.52	18.44	7.83	15.63	8.45
	6	24.86	6.46	22.96	6.82	22.12	7.19	21.94	7.79	21.08	8.29	20.72	8.82	20.00	9.87
	7	25.22	6.68	23.70	7.36	23.14	8.11	22.74	8.77	22.07	9.26	21.81	9.59	21.28	10.25
	8	25.58	7.61	24.46	8.50	23.97	8.89	23.64	9.79	22.96	10.13	22.50	10.69	21.59	11.80
	9	26.01	7.89	25.15	9.54	24.77	10.28	24.39	10.58	23.57	11.28	23.24	11.63	22.58	12.34
	10	26.38	8.53	25.86	10.43	25.63	11.28	25.21	11.75	24.03	12.28	23.69	12.74	22.80	13.66
M4AC100BRE	5	27.55	5.83	26.94	7.28	26.67	7.92	26.26	8.83	24.68	9.78	24.17	10.44	23.16	11.77
	6	30.28	6.42	28.19	8.13	27.26	8.89	26.48	9.65	25.14	10.72	24.47	11.20	23.25	12.17
	7	32.94	7.35	29.56	9.11	28.05	9.89	26.71	10.74	25.76	11.81	24.74	12.38	23.61	13.51
	8	34.80	8.28	30.53	9.99	28.62	10.75	27.50	11.71	26.32	12.68	25.27	13.33	24.01	14.64
	9	37.02	8.68	31.69	11.06	29.32	12.12	28.23	12.72	27.02	13.46	25.72	14.15	24.43	15.52
	10	39.74	10.09	33.06	11.92	30.09	12.73	28.79	13.41	27.53	14.22	26.35	14.98	25.03	16.50
M4AC120BRE	5	41.65	9.52	36.74	11.37	34.56	12.20	34.45	12.31	32.96	13.32	31.25	15.03	27.84	18.0
	6	42.65	10.73	37.78	12.48	35.62	12.81	34.98	13.38	33.31	14.70	32.13	15.92	28.92	18.36
	7	44.29	11.77	39.09	13.35	36.78	14.06	35.80	14.58	34.11	16.32	32.94	17.80	29.65	20.78
	8	46.43	13.18	41.15	14.32	38.80	14.82	37.85	15.89	35.27	17.67	33.56	19.54	30.54	23.28
	9	47.38	13.56	42.02	15.19	40.56	15.92	39.21	17.79	36.32	18.96	34.14	20.87	30.90	24.67
	10	48.95	15.10	43.59	16.37	42.15	16.94	40.53	18.70	37.40	20.31	34.81	22.02	31.66	25.44

Heating In Heat Pump Version

MODEL	LEAVING WATER TEMPERATURE(°C)	AMBIENT TEMPERATURE ON CONDENSER (°C)															
		-7		-5		0		4		7		10		15		20	
		HEAT CAP. KW	POWER INPUT kW	HEAT CAP. KW	POWER INPUT kW	HEAT CAP. KW	POWER INPUT kW	HEAT CAP. KW	POWER INPUT kW	HEAT CAP. KW	POWER INPUT kW	HEAT CAP. KW	POWER INPUT kW	HEAT CAP. KW	POWER INPUT kW	HEAT CAP. KW	POWER INPUT kW
M4AC075BRE	35	14.57	6.96	21.20	7.75	24.50	8.15	26.26	8.34	27.64	8.61	28.55	8.85	30.15	9.13	32.71	9.58
	40	11.93	7.71	19.56	8.10	23.41	8.40	25.19	8.61	27.05	8.85	27.71	9.17	29.46	9.41	32.20	9.78
	45	10.12	8.20	18.17	8.45	22.15	8.65	24.49	8.92	26.43	9.10	27.14	9.43	28.62	9.67	30.99	10.04
	50					20.63	8.89	23.63	9.14	25.88	9.44	24.02	9.70	27.91	10.18	30.22	10.94
	55					18.65	9.14	22.31	9.29	25.06	9.67	25.93	10.12	26.91	10.59	28.48	11.34
M4AC100BRE	35	17.02	7.58	23.14	8.17	26.20	8.47	27.89	8.58	30.11	8.96	31.03	9.39	32.04	9.85	33.65	10.59
	40	16.29	8.11	21.82	8.54	24.57	8.78	27.07	9.04	29.11	9.58	30.19	9.88	31.11	10.42	32.57	11.21
	45	13.59	8.62	20.44	9.12	23.88	9.36	26.34	9.64	28.42	9.92	29.17	10.36	30.11	11.16	31.45	12.23
	50					22.26	9.94	25.25	9.96	27.50	10.53	28.40	10.94	29.49	11.50	30.80	12.44
	55					21.02	10.52	24.25	10.65	26.68	11.07	27.58	11.59	28.57	11.93	30.15	12.48
M4AC125BRE	35	22.61	10.37	30.99	11.40	35.18	11.91	39.98	13.03	43.87	13.86	47.15	14.26	50.74	14.65	56.45	15.20
	40	21.29	10.49	29.24	12.02	33.25	12.84	38.59	13.64	42.53	14.35	46.03	14.89	49.73	15.20	55.68	15.71
	45	18.21	11.50	27.38	12.81	31.96	13.46	37.11	14.20	41.22	14.89	44.79	15.42	48.50	15.75	54.37	16.26
	50					31.26	14.08	36.30	14.88	40.42	15.42	43.97	15.75	47.00	16.02	51.84	16.49
	55					30.70	14.68	35.65	15.33	39.53	15.91	43.54	16.20	45.71	16.45	49.17	16.85

Technical Data

Evaporator pressure drop and Hydraulic lift

MAC/ M4AC040A/AR M4AC040AE/ARE			MAC/ M4AC050A/AR M4AC050AE/ARE			MAC/ M4AC058A/AR M4AC058AE/ARE		
Flowrate (m3/hr)	Pressure drop kPa	Hydraulic lift kPa (*)	Flowrate (m3/hr)	Pressure drop kPa	Hydraulic lift kPa (*)	Flowrate (m3/hr)	Pressure drop kPa	Hydraulic lift kPa (*)
0.72	10	249	0.86	5	250	1.15	7	240
1.22	21	223	1.19	12	233	1.44	13	227
1.51	38	176	2.02	35	179	2.20	28	181
2.20	79	130	2.56	58	127	2.52	37	150
2.50	99	89	3.53	108	23	4.18	74	27

MAC/ M4AC075A/AR M4AC075AE/ARE			MAC/ M4AC100A/AR M4AC100AE/ARE			MAC/ M4AC125A/AR M4AC125AE/ARE		
Flowrate (m3/hr)	Pressure drop kPa	Hydraulic lift kPa (*)	Flowrate (m3/hr)	Pressure drop kPa	Hydraulic lift kPa (*)	Flowrate (m3/hr)	Pressure drop kPa	Hydraulic lift kPa (*)
2.05	10	281	2.77	6	270	3.49	12	248
3.17	22	249	3.67	10	245	4.43	19	210
4.03	33	216	5.04	18	197	6.30	37	131
4.75	45	179	6.19	26	150	8.03	57	32
5.80	65	132	7.60	37	75	8.46	63	18

(*) Hydraulic lift = Pump lift -(evaporator pressure drop + hydraulic kit pressure drop)

Correction Factors with GLYCOL use

LWT/ deg C	CAPACITY FACTOR			
	GLYCOL %			
	10	20	30	40
-12.2			0.8	0.7
-9.4			0.827	0.735
-6.7		0.88	0.85	0.756
-3.9		0.9	0.876	0.781
-1.1	0.925	0.925	0.892	0.796
1.7	0.945	0.938	0.906	0.809
4.4	0.956	0.949	0.918	0.82
7.2	0.965	0.959	0.927	0.829
10.0	0.962	0.957	0.926	0.828

GLYCOL %	WATER FLOW	PRESSURE DROP
10	1.015	1.06
20	1.040	1.12
30	1.080	1.18
40	1.135	1.24

Outlines and Dimensions

Model : MAC040 / 050 / 058A/AR, M4AC040 / 050 / 058A/AR

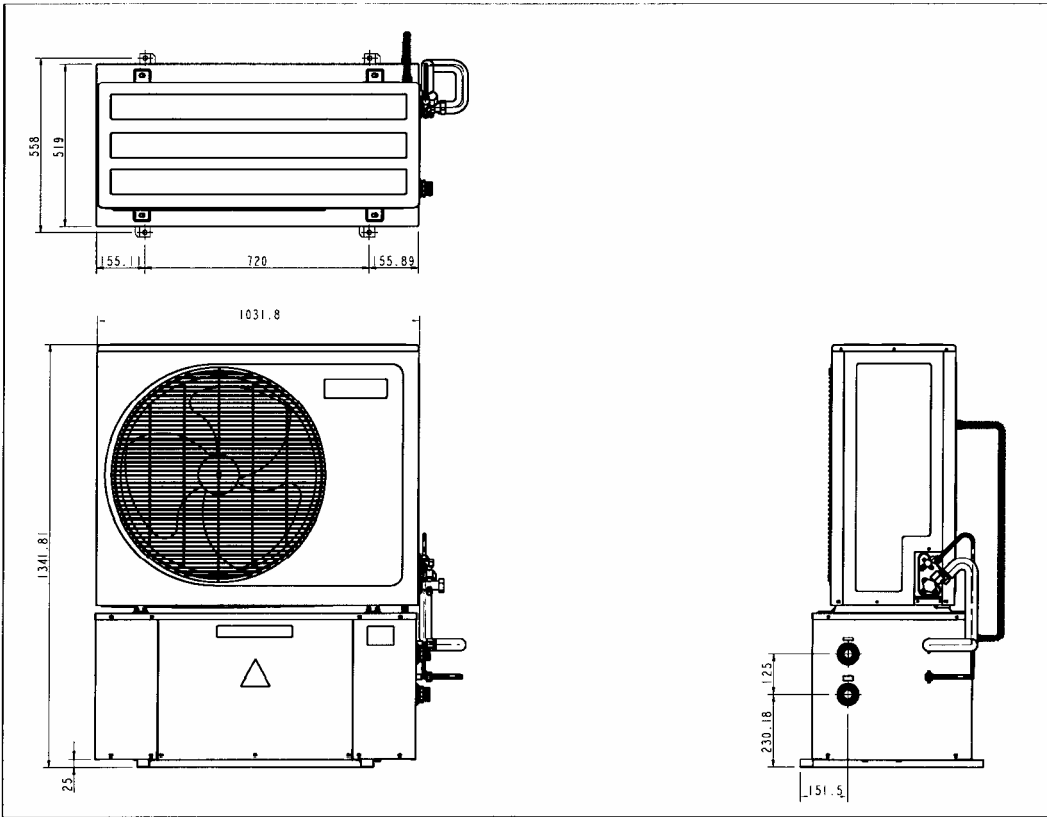

Bottom Compartment

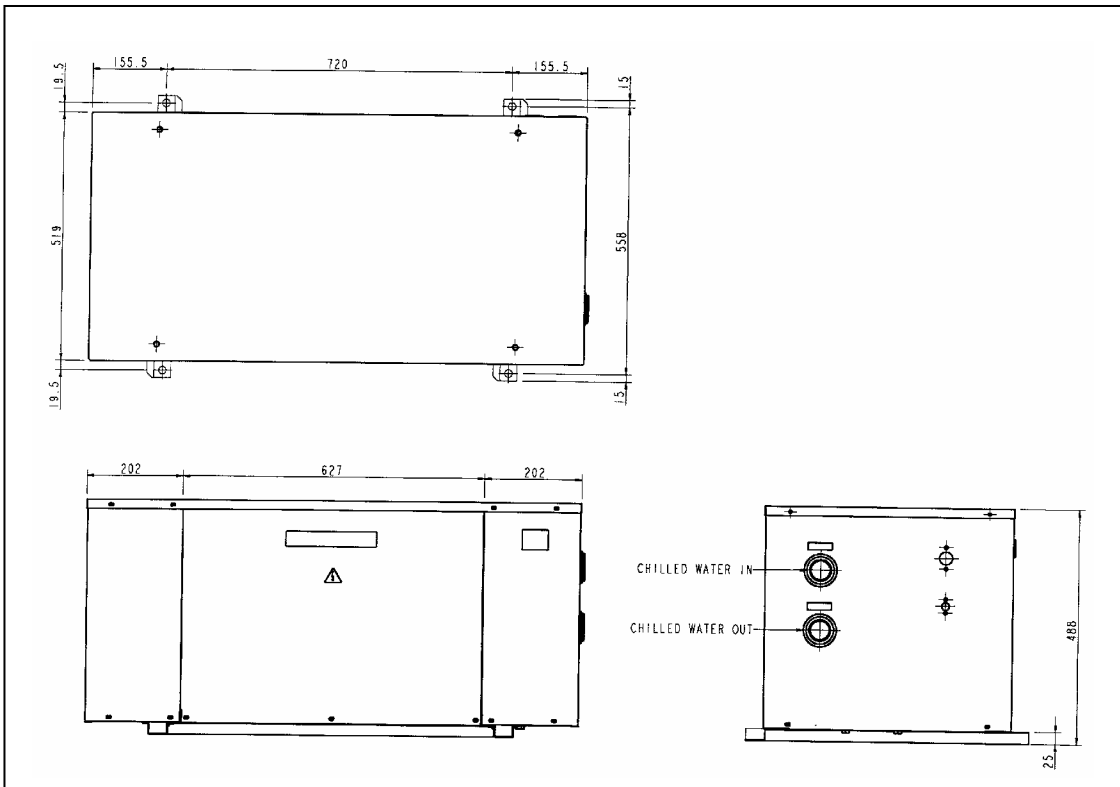

Model : MAC075 / 100 / 125B/BR

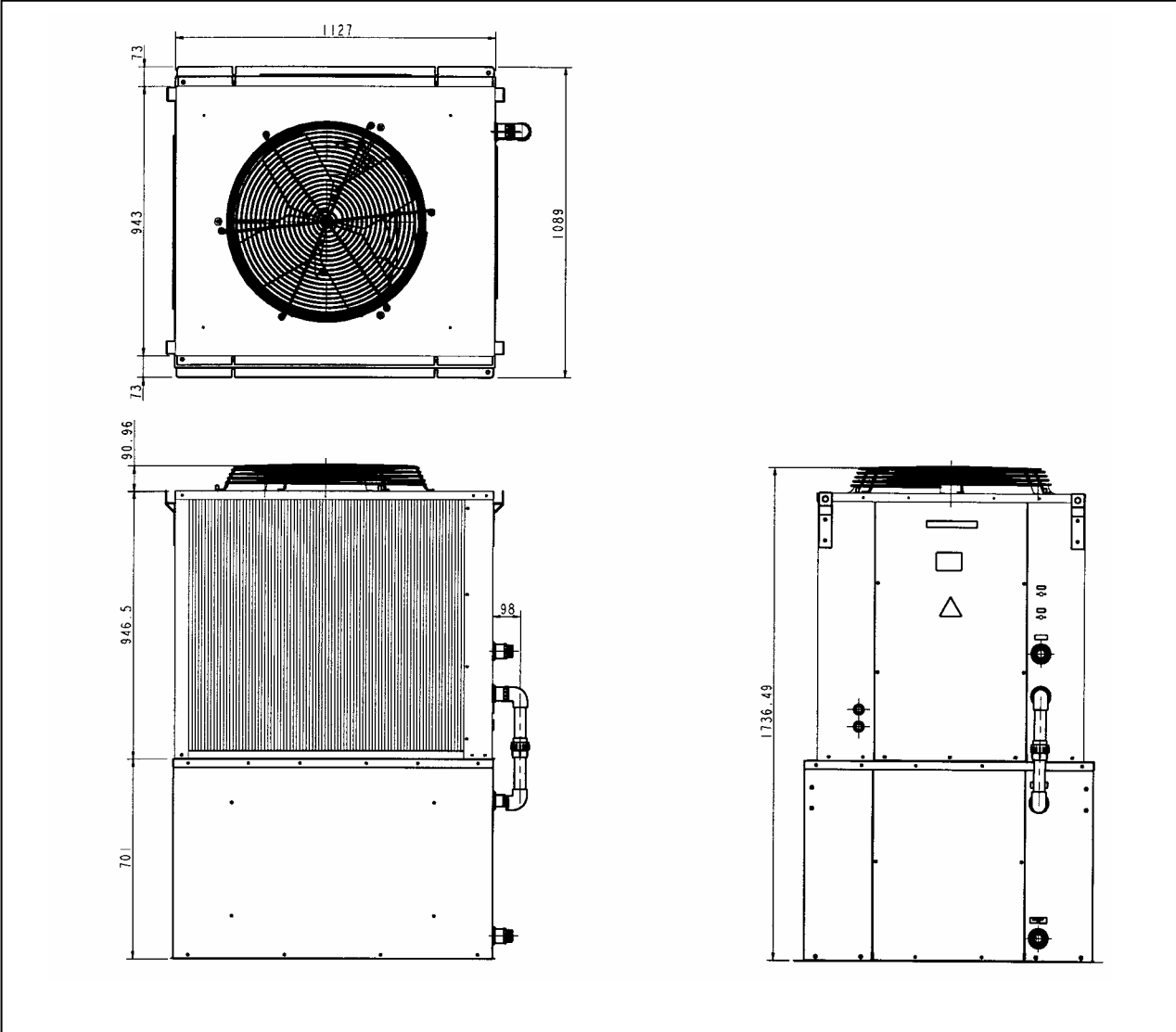

Top Compartment

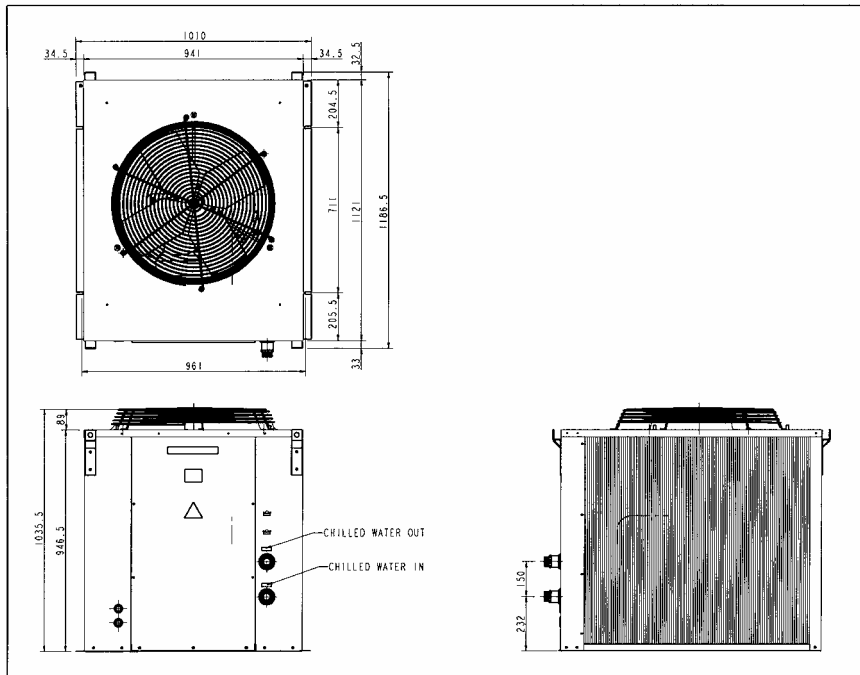

Bottom Compartment

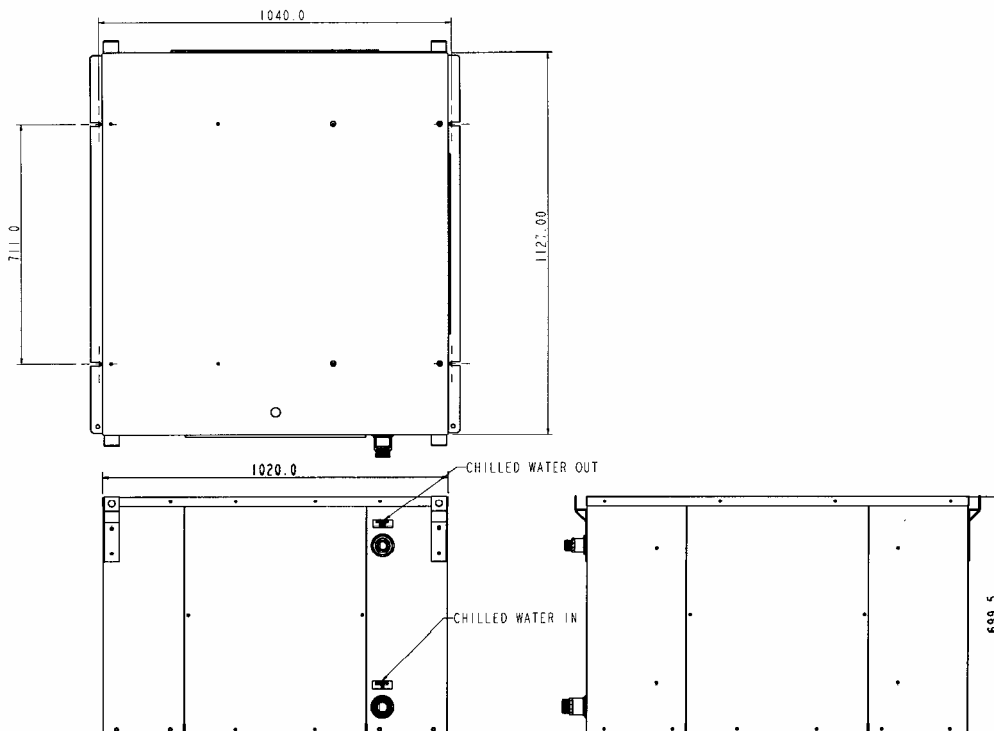

Wiring Diagrams

Model : MAC040 / 050 A, M4AC040 / 050A (Cooling Only)

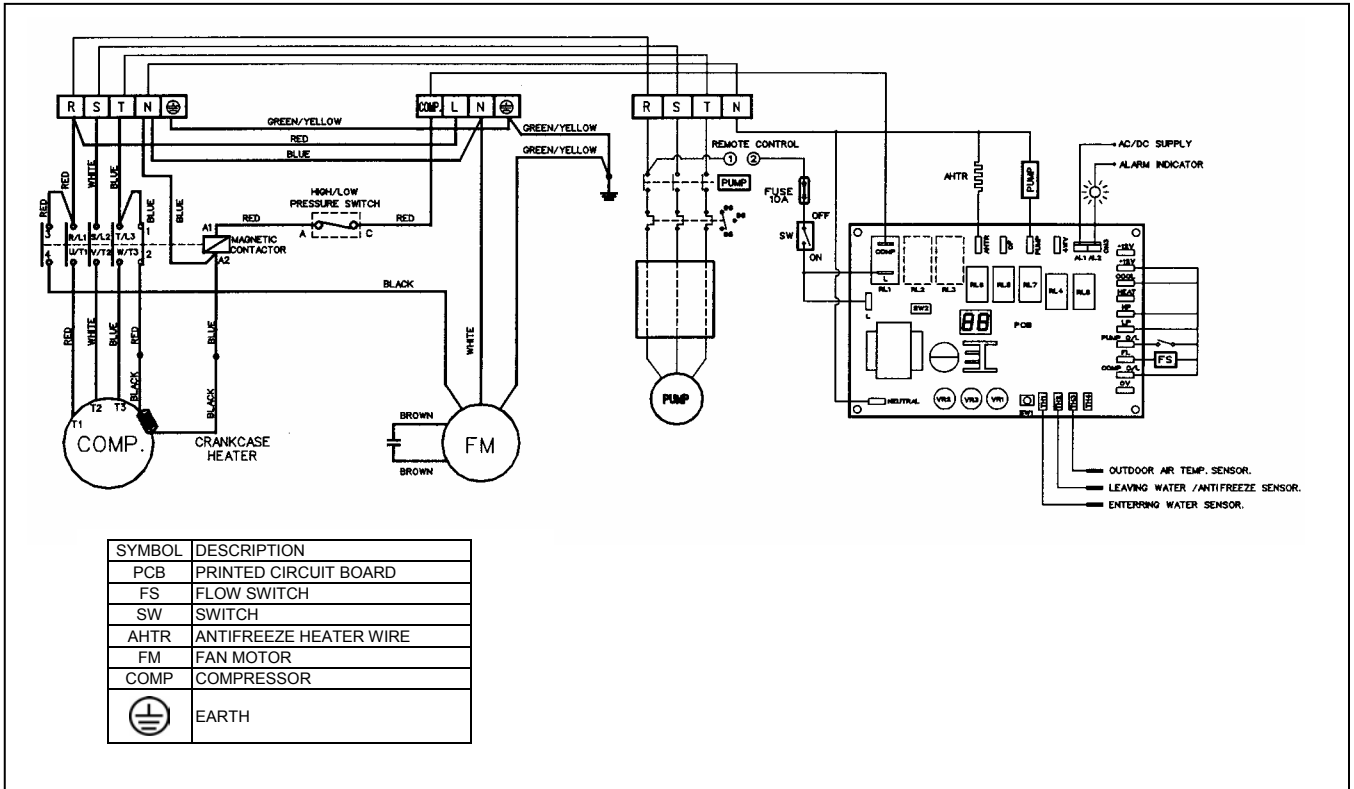

Model : MAC058A , M4AC058A (Cooling Only)

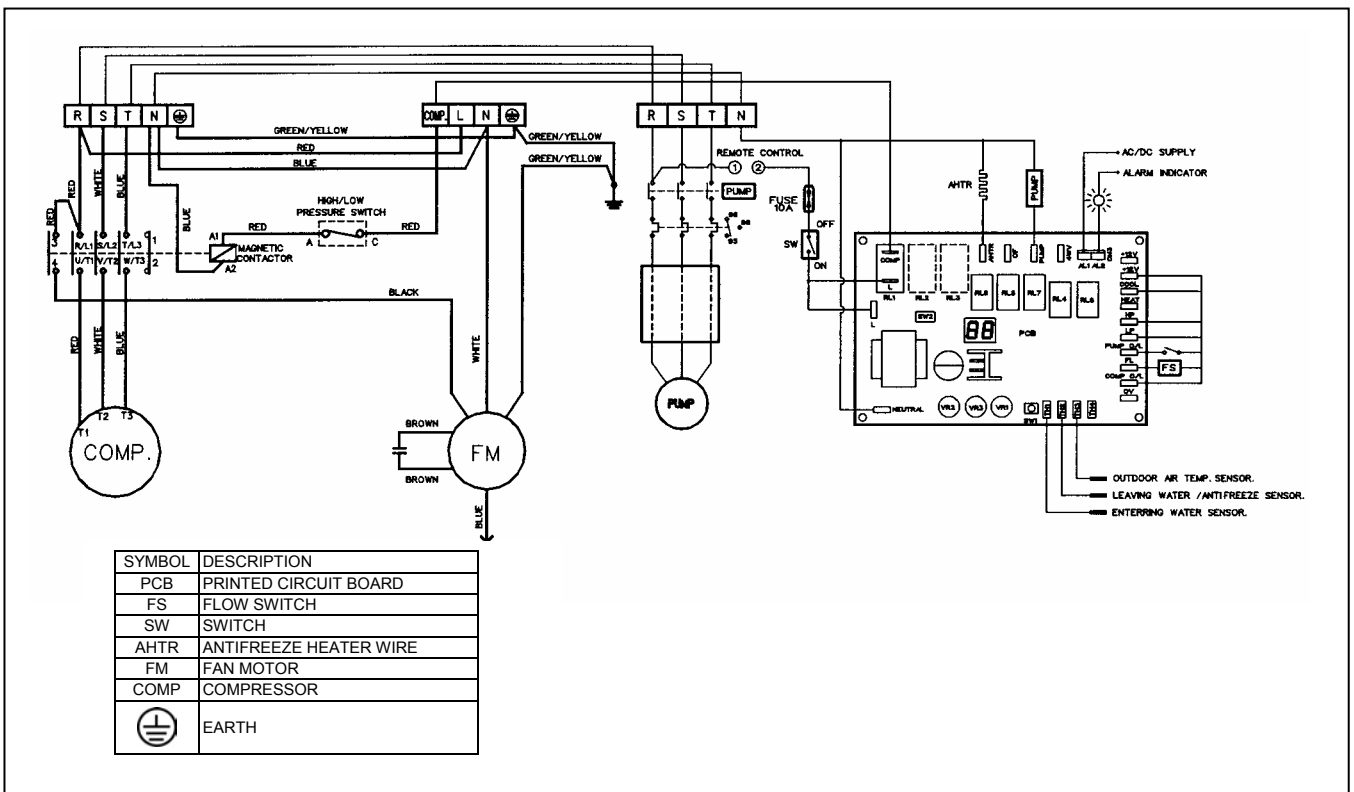

Model : MAC040 / 050 / 058AR , M4AC040 / 050 / 058AR (Heat Pump)

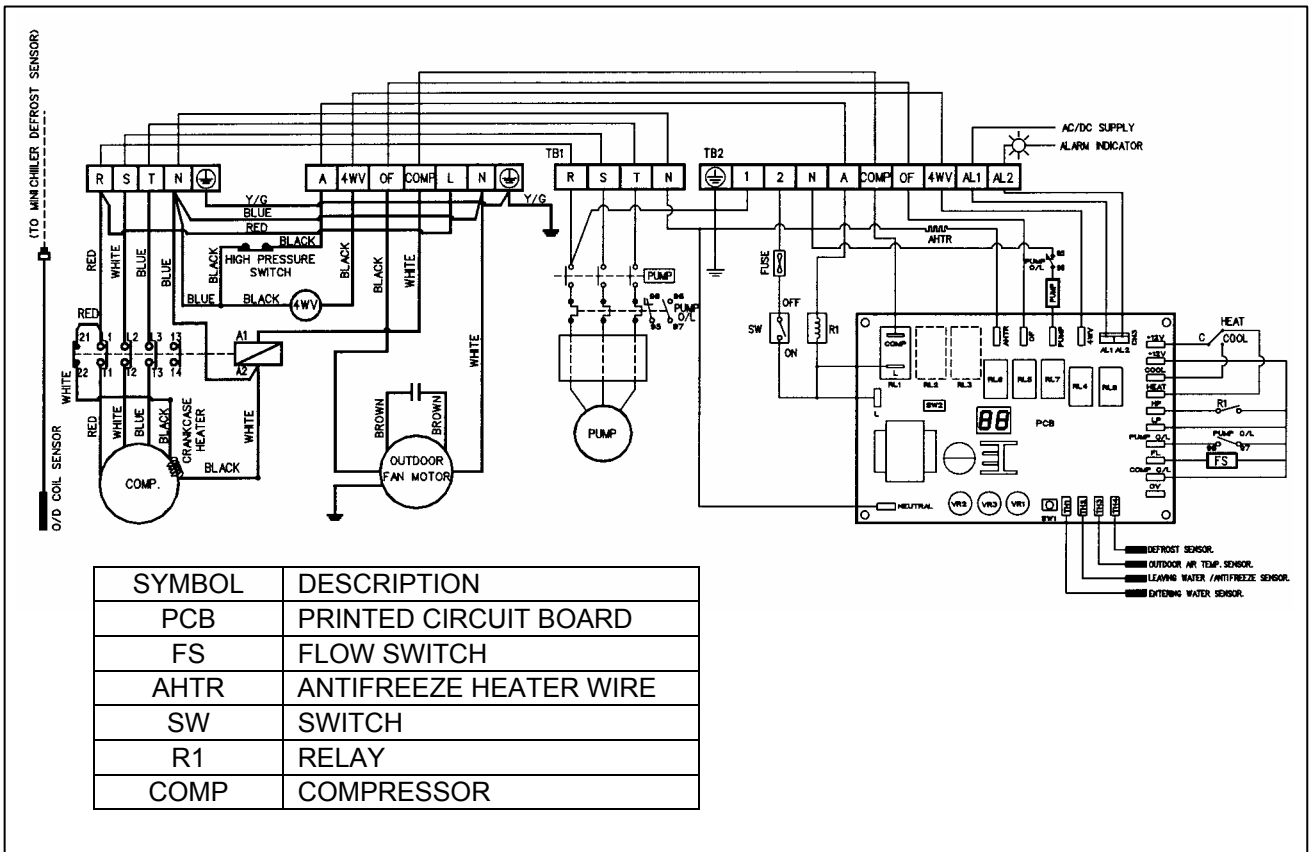

Model : MAC075 / 100 / 125B (Cooling Only)

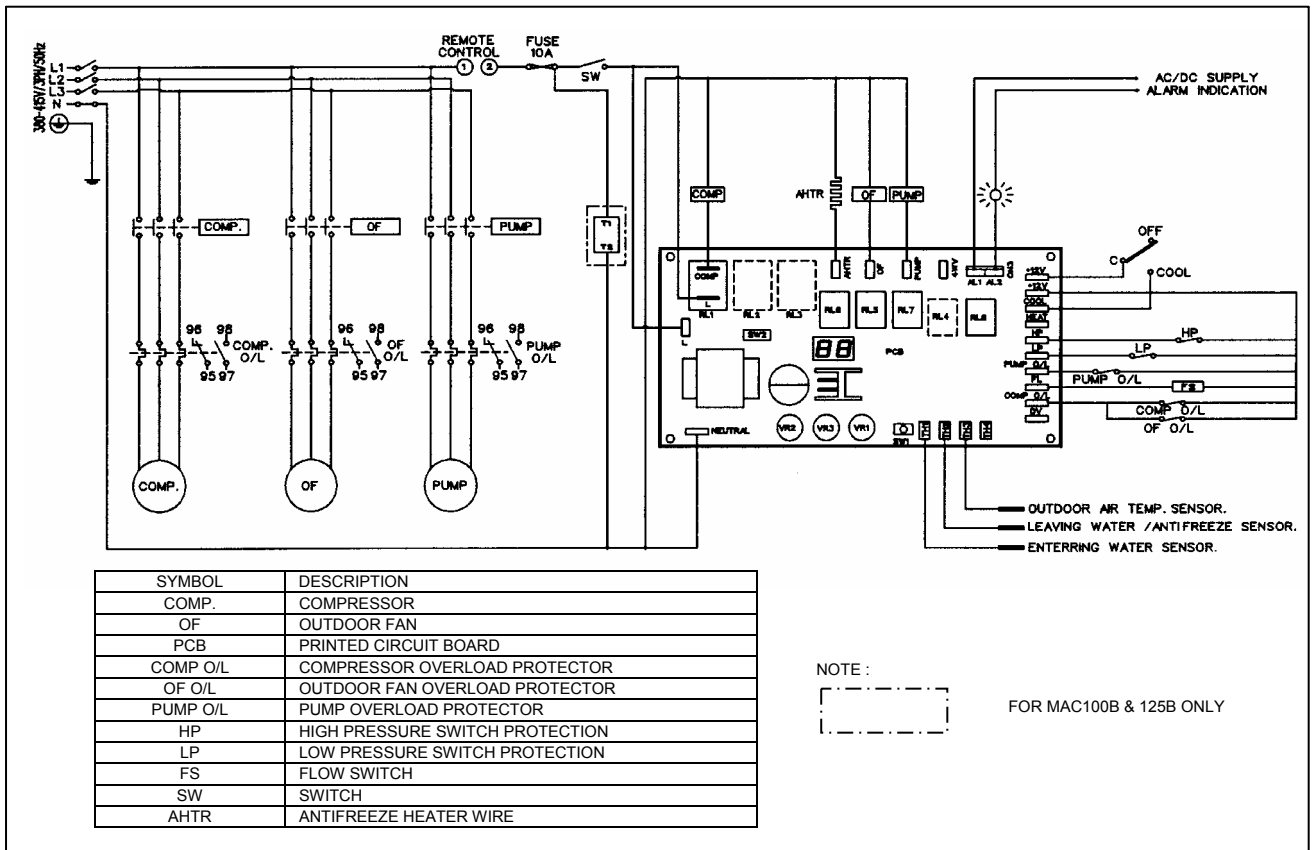

Model : MAC075 / 100 / 125BR (Heat Pump)

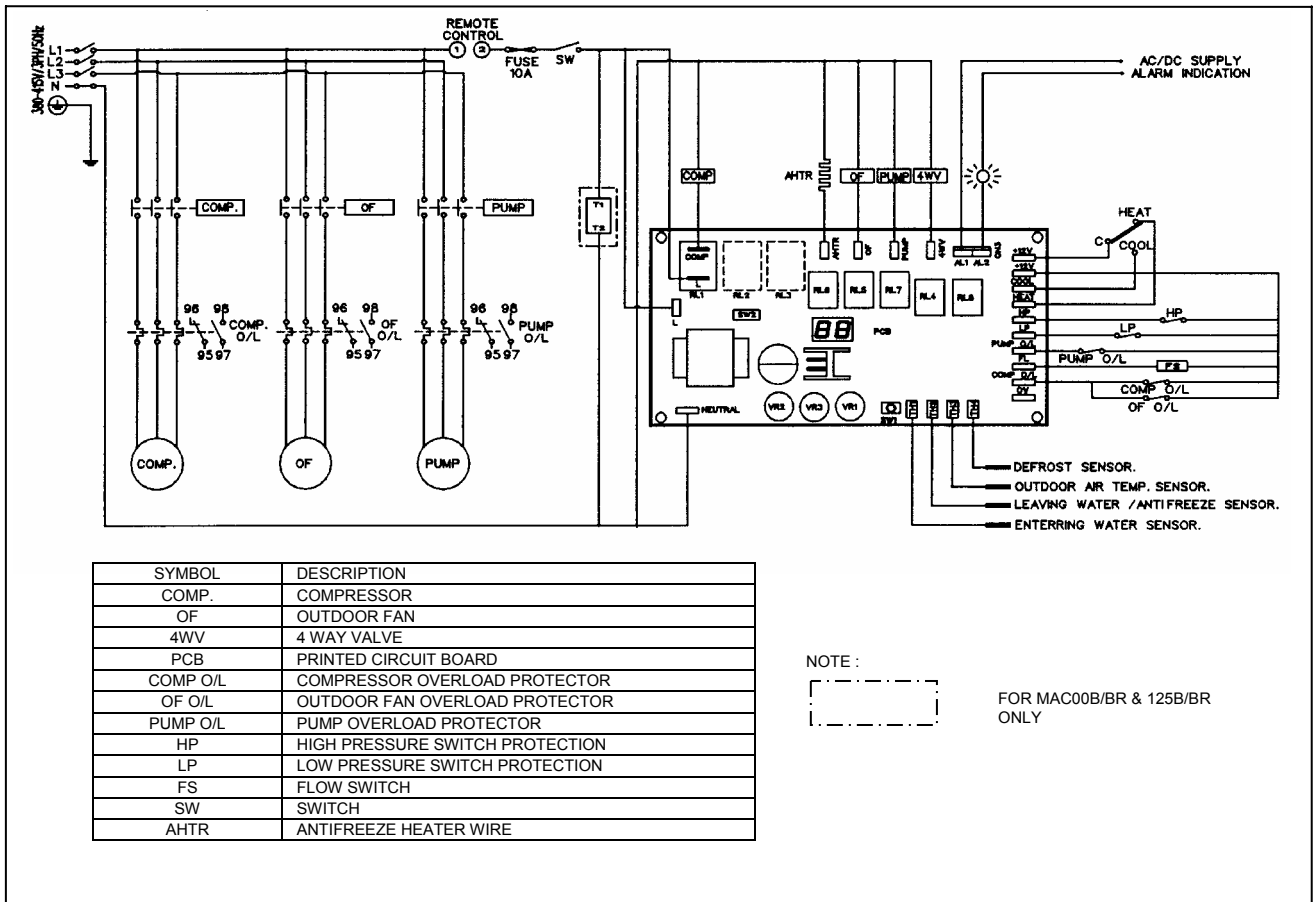

Model : MAC075 / 100 / 125B (Cooling Only)

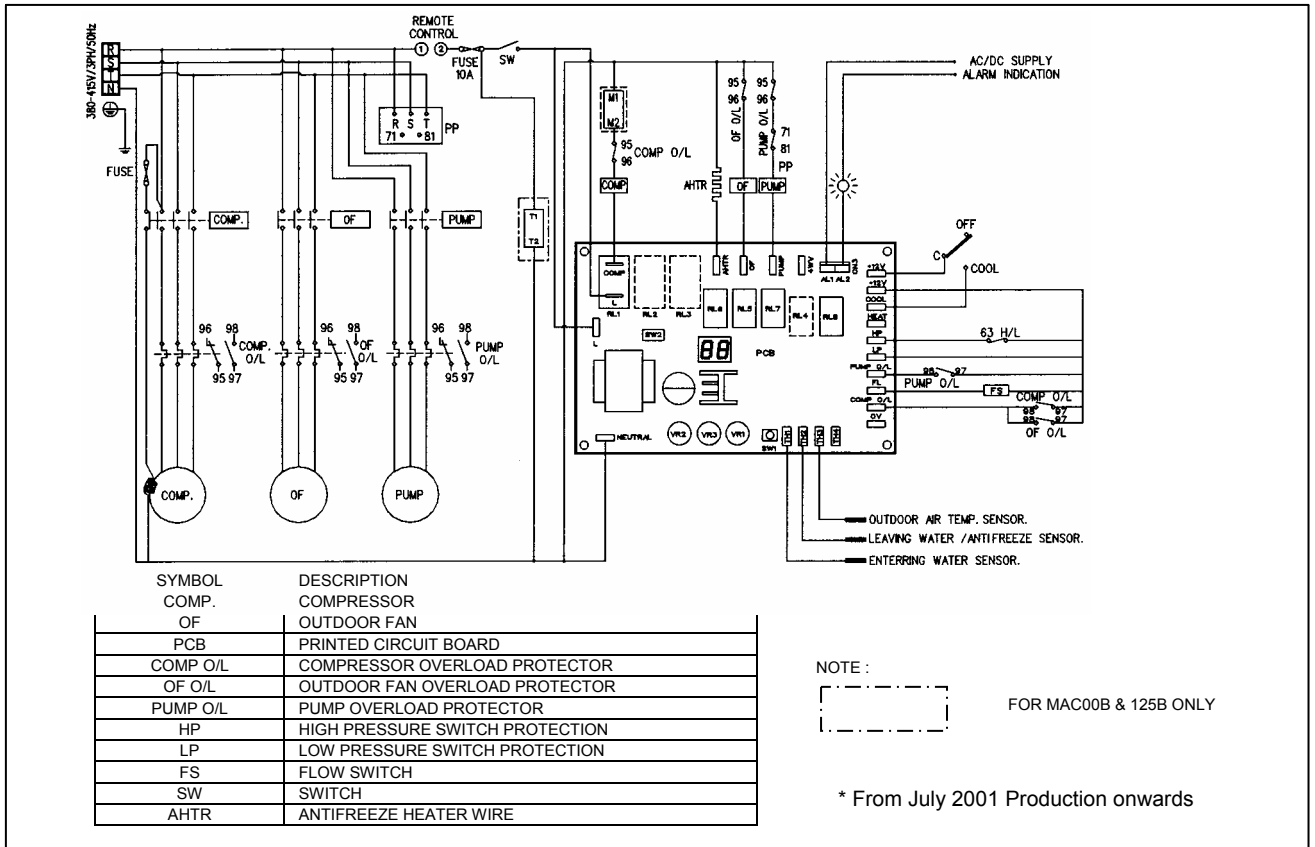

Model : MAC075 / 100 / 125BR (Heat Pump)

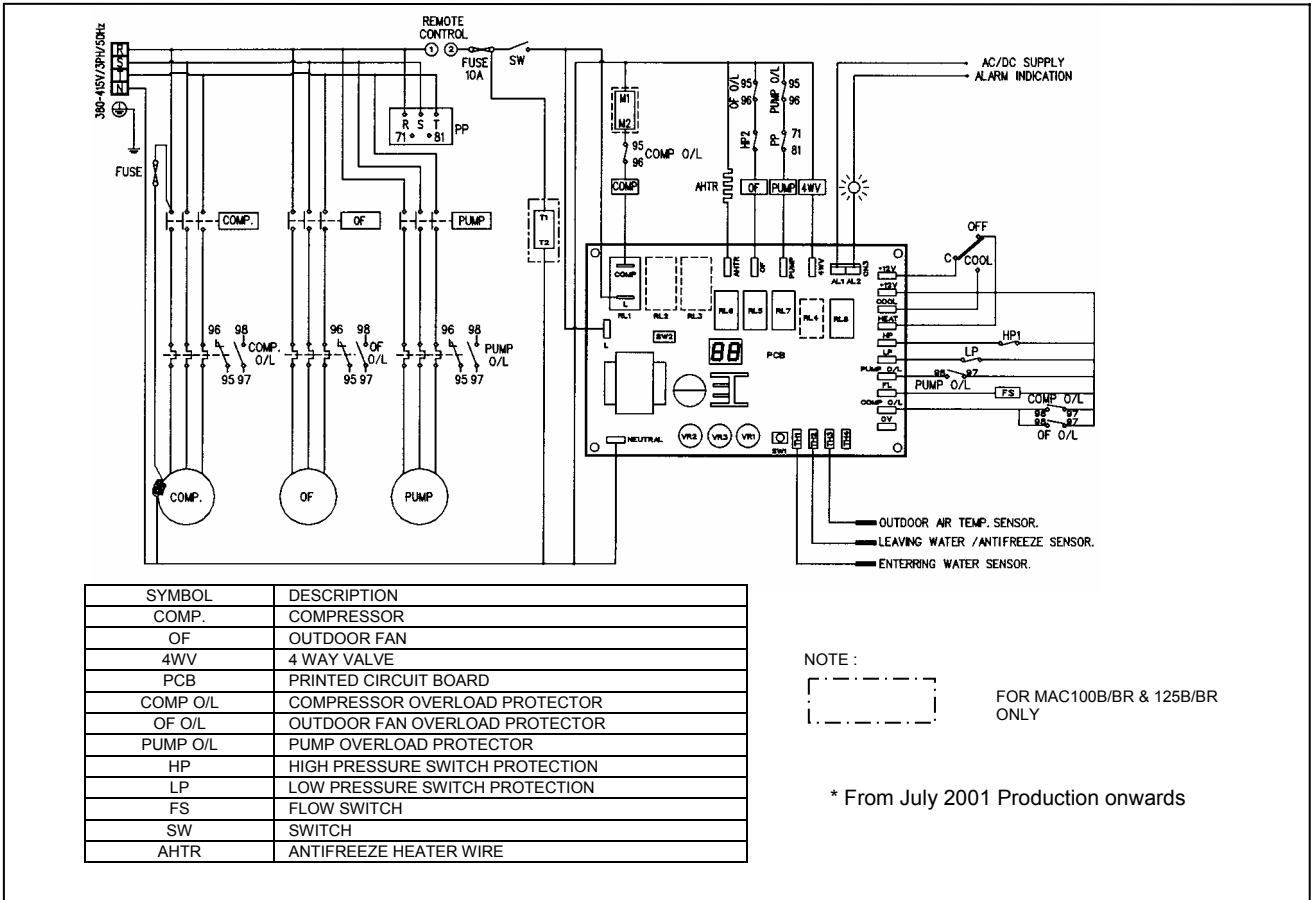

Model : M4AC040 / 050 / 058AE

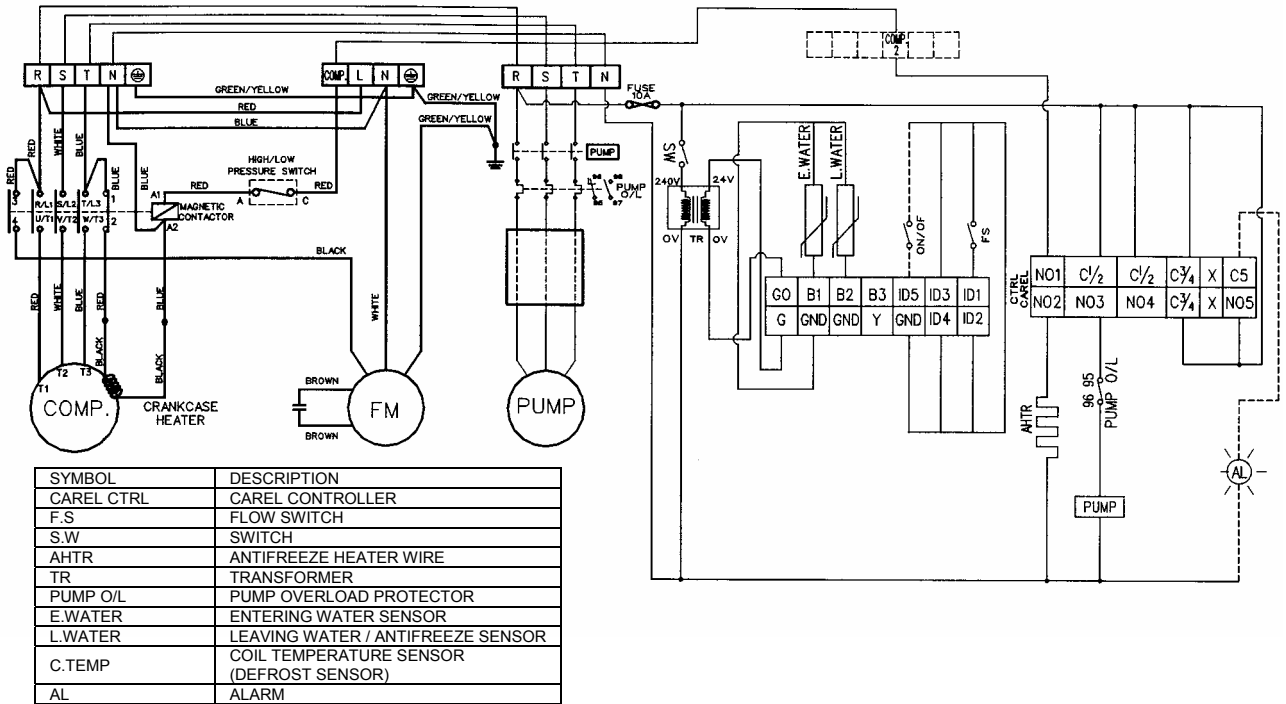

Model : M4AC040 / 050 / 058ARE

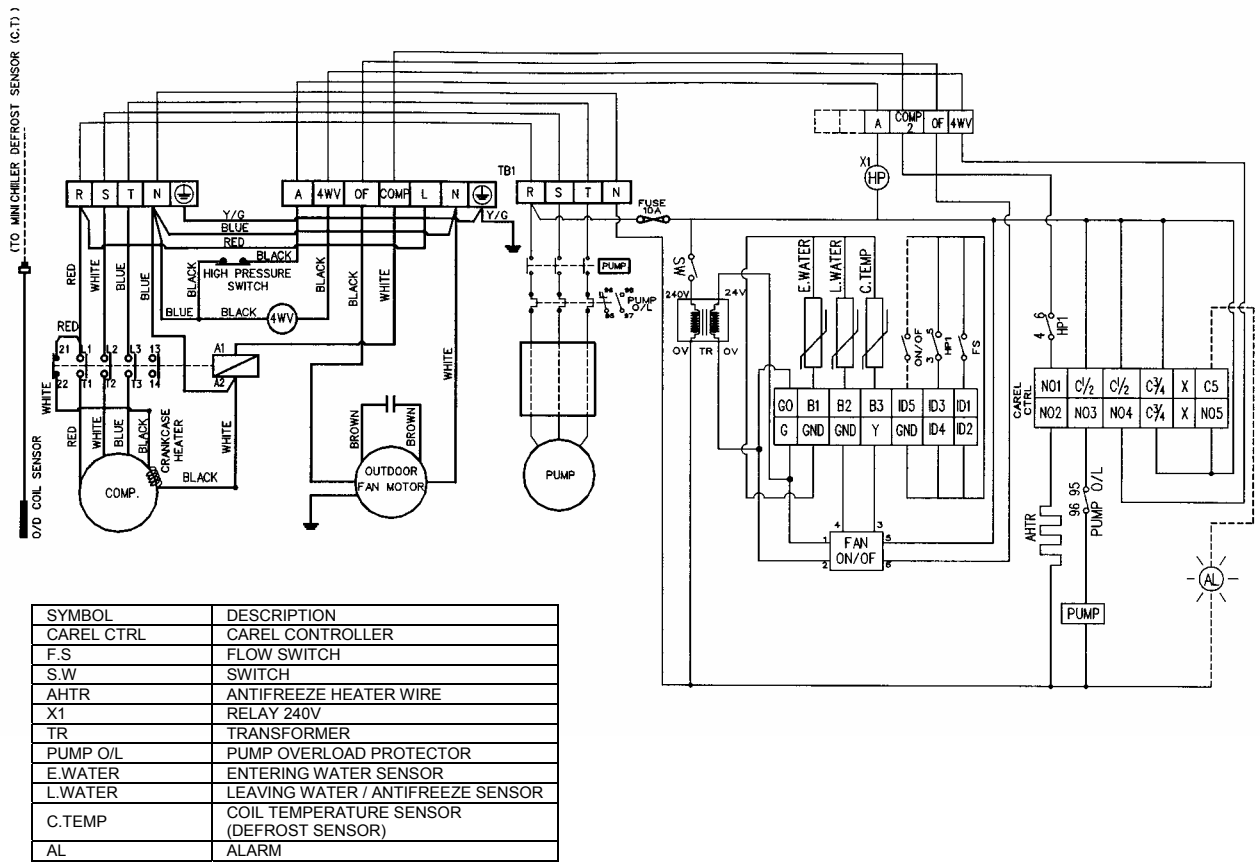

Model : M4AC075 / 100 / 125BE

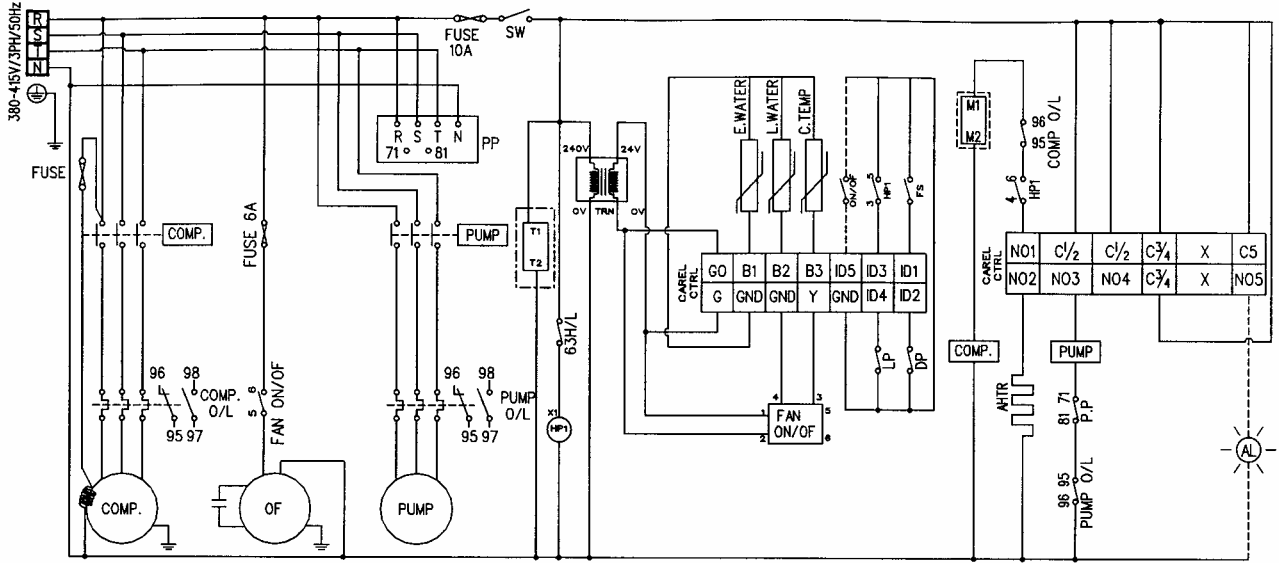

SYMBOL	DESCRIPTION	SYMBOL	DESCRIPTION
COMP.	COMPRESSOR	FS	FLOW SWITCH
OF	OUTDOOR FAN	SW	SWITCH
CAREL CTRL	CAREL CONTROLLER	AHTR	ANTIFREEZE HEATER WIRE
COMP O/L	COMPRESSOR OVERLOAD PROTECTOR	PP	PHASE PROTECTOR
X1	RELAY 240V	E.WATER	ENTERING WATER SENSOR
PUMP O/L	PUMP OVERLOAD PROTECTOR	L.WATER	LEAVING WATER / ANTIFREEZE SENSOR
63 HL	HIGH LOW PRESSURE SWITCH	C.TEMP	COIL TEMPERATURE SENSOR
AL	ALARM		

NOTE :
 [---] FOR MAC125BE ONLY

Model : M4AC075 / 100 / 125BRE

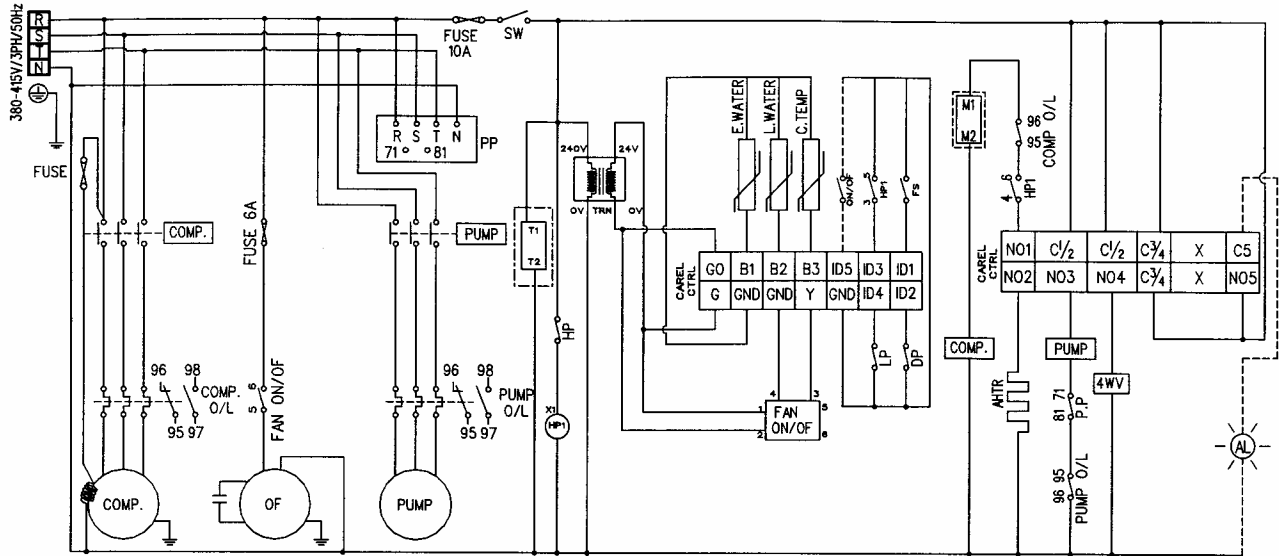

SYMBOL	DESCRIPTION	SYMBOL	DESCRIPTION
COMP.	COMPRESSOR	S.W	SWITCH
OF	OUTDOOR FAN	AHTR	ANTIFREEZE HEATER WIRE
CAREL CTRL	CAREL CONTROLLER	PP	PHASE PROTECTOR
COMP O/L	COMPRESSOR OVERLOAD PROTECTOR	E.WATER	ENTERING WATER SENSOR
X1	RELAY 240V	L.WATER	LEAVING WATER / ANTIFREEZE SENSOR
PUMP O/L	PUMP OVERLOAD PROTECTOR	C.TEMP	COIL TEMPERATURE SENSOR
HP	HIGH PRESSURE SWITCH 30 Kg/cm ²	DP	DEFROST PRESSURE SWITCH 19 Kg/cm ²
AL	ALARM	LP	LOW PRESSURE SWITCH 0.5 Kg/cm ²
F.S	FLOW SWITCH	4WV	4 WAY VALVE

NOTE :
 [---] FOR MAC125BE ONLY

Special Precautions for R407C

Special Precautions When Dealing With Refrigerant R407C Unit

1) What is new refrigerant R407C?

R407C is a zeotropic refrigerant mixture which has Zero Ozone Depletion Potential (ODP = 0) and thus conformed to the Montreal Protocol regulation. It requires Polyol-ester oil (POE) oil for its compressor's lubricant. Its refrigerant capacity and performance are about the same as the refrigerant R22.

2) Components

Mixture weight composition R32(23%), R125(25%), R134a(52%)

3) Characteristic

- R407C liquid and vapor components have different compositions when the fluid evaporates or condenses. Hence, when leak occurs and only vapor leaks out, the composition of the refrigerant mixture left in the system will change and subsequently affect the system performance. **DO NOT** add new refrigerant to leaked system. It is recommended that the system should be evacuated thoroughly before recharging with R407C.
- When refrigerant R407C is used, the composition will differ depending on whether it is in gaseous or liquid phase. Hence when charging R407C, ensure that only liquid is being withdrawn from the cylinder or can. This is to make certain that only original composition of R407C is being charged into the system.
- POE oil is used as lubricant for R407C compressor, which is different from the mineral oil used for R22 compressor. Extra precaution must be taken not to expose the R407C system too long to moist air.

4) Check list before installation/servicing

- Tubing
Refrigerant R407C is more easily affected by dust or moisture compared with R22, make sure to temporarily cover the ends of the tubing prior to installation
- Compressor oil
No additional charge of compressor oil is permitted.
- Refrigerant
No other refrigerant other than R407C
- Tools
Tools specifically for R407C only (must not be used for R22 or other refrigerant)
 - i) Manifold gauge and charging hose
 - ii) Gas leak detector
 - iii) Refrigerant cylinder/charging cylinder
 - iv) Vacuum pump c/w adapter
 - v) Flare tools
 - vi) Refrigerant recovery machine

5) Handling and installation guidelines

Like R22 system, the handling and installation of R407C system are closely similar. All precautionary measures; such as ensuring no moisture, no dirt or chips in the system, clean brazing using nitrogen, and thorough leak check and vacuuming are equally important requirements. However, due to zeotropic nature of R407C and its hydroscopic POE oil, additional precautions must be taken to ensure optimum and trouble-free system operation.

- a) Filter-dryer must be installed along the liquid line for all R407C air conditioners. This is to minimise the contamination of moisture and dirt in the refrigerant system. Filter-dryer must be of molecular sieve type. For a heat-pump system, install a two-way flow filter dryer along the liquid line.
- b) During installation or servicing, avoid prolong exposure of the internal part of the refrigerant system to moist air. Residual POE oil in the piping and components can absorb moisture from the air.

- c) Ensure that the compressor is not exposed to open air for more than the recommended time specified by its manufacturer (typically less than 10 minutes). Remove the seal-plugs only when the compressor is about to be brazed.
- d) The system should be thoroughly vacuumed to 1.0 Pa (-700mmHg) or lower. This vacuuming level is more stringent than R22 system so as to ensure no incompressible gas and moisture in the system.
- e) When charging R407C, ensure that only liquid is being withdrawn from the cylinder or can. This is to ensure that only the original composition of R407C is being delivered into the system. The liquid composition can be different from the vapor composition.

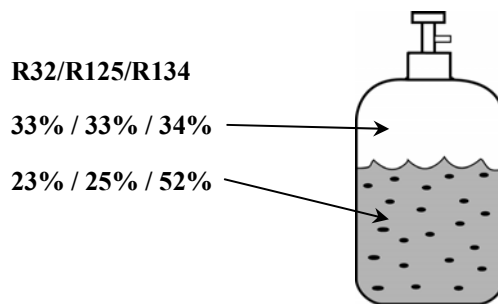

Composition of R407C in vapour phase is different from liquid phase.

- f) Normally, the R407C cylinder or can is being equipped with a dip-pipe for liquid withdrawal. However, if the dip-pipe is not available, invert the cylinder or can so as to withdraw liquid from the valve at the bottom.

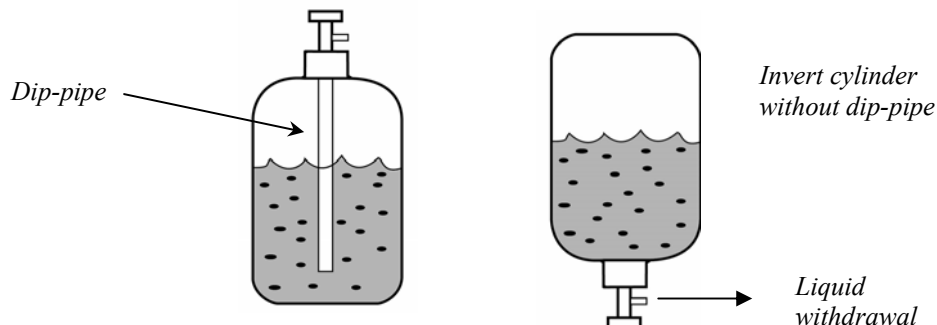

- g) When servicing a leak, the top-up method, commonly practiced for R22 system, is not recommended for R407C system. Unlike R22 where the refrigerant is of a single component, the composition of R407C, which is made up of three different components, may have changed during the leak. Consequently, a top-up may not ensure that the R407C in the system is of original composition. This composition shift may adversely affect the system performance. It is recommended that the system should be evacuated thoroughly before recharging with R407C.

Installation

Location for Installation

In order to achieve maximum cooling capacity, the location selection should fulfill the following requirements:

- a) Install the chiller in such a way that the hot air discharge cannot be drawn in again.

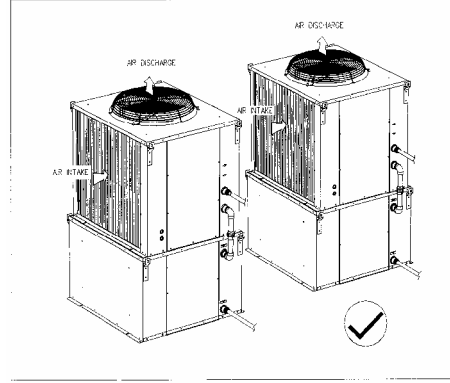
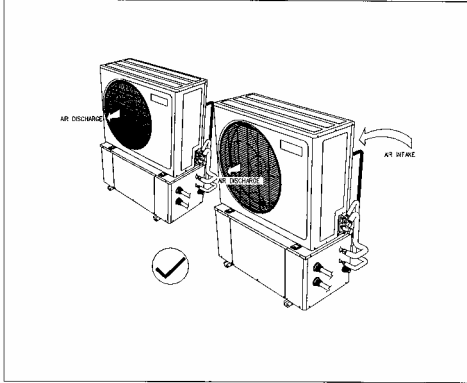

- b) Ensure that there is no obstruction to air flow into or out of the unit. Remove obstacles which blocking intake or discharge air.

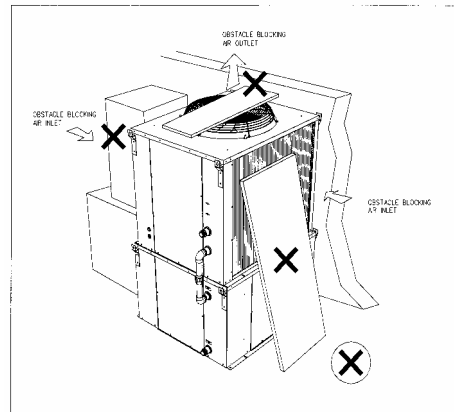
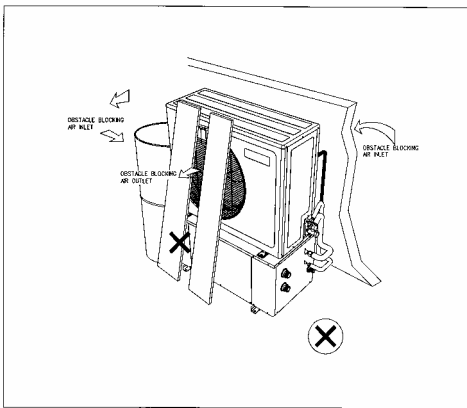

- c) The location must be well ventilated, so that air can be drawn in and discharge out efficiently.

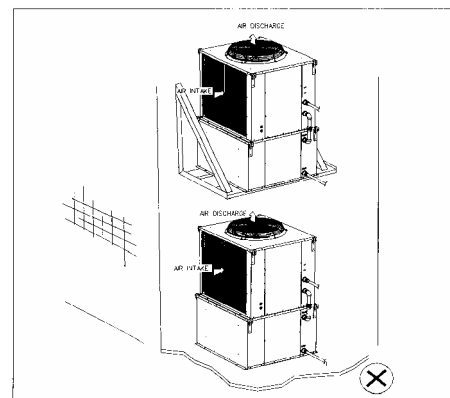
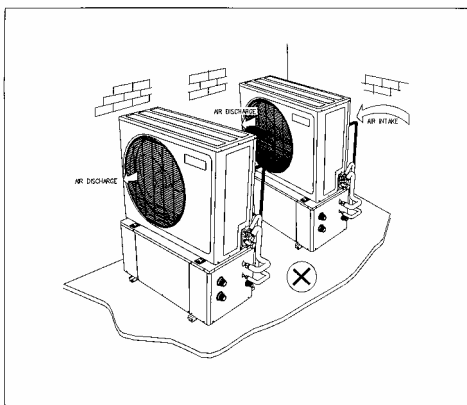

- d) Choose a place which can rigidly support the weight of the unit, this will help to minimize vibration and noise.

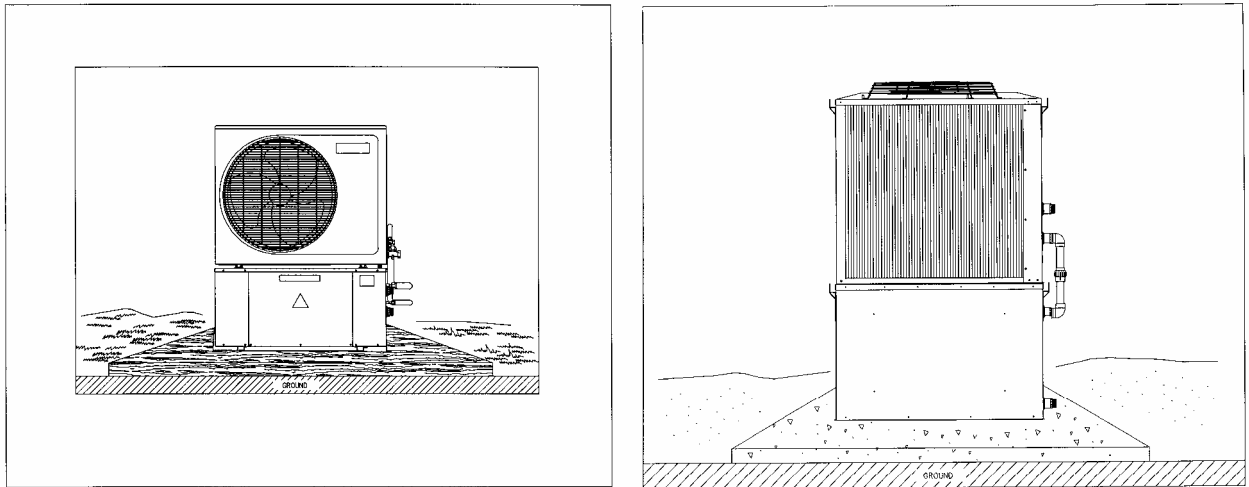

- e) The location must not be susceptible to dust or oil to avoid condenser coil being choke by the contaminant. As the general safety precaution, it is advised that no flammable danger gas should be located near to the unit.
- f) Water source of the cooler must be clean and free from any contaminant such as rusted particles or any kind of oil. It is necessary to install a water filter in the returning water line.

Installation Pipe Length

The water connection pipes are 1 1/4" BSPT female or 1 1/4" DIN female for both water inlet and water outlet. The piping network should be designed with as few bends as possible and with as few variations in elevation as possible. This will reduce the cost of the installation and improve unit performance. The recommended maximum pipe length for piping insulation is 120 meters. Simple calculation for friction loss of the water head is needed. It is advised that the minimum pipe size is 1 1/4".

Caution:

If the chiller is operated under very oily, salty or acidic atmosphere or water, these substances may lead to capacity drop or failure of the unit.

Be sure to use clean water when filling in the water circuit to avoid heavy corrosion and choking of the system.

Installation Clearance

It is advised to have sufficient clearance around the unit for proper condenser air flow and to facilitate access for maintenance. (see clearance shown in figure below)

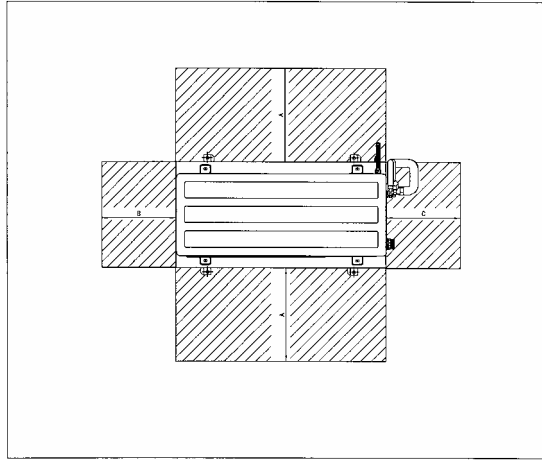

Model	A	B	C
MAC040 – 058A MAC040 – 058AR	950mm	900mm	900mm

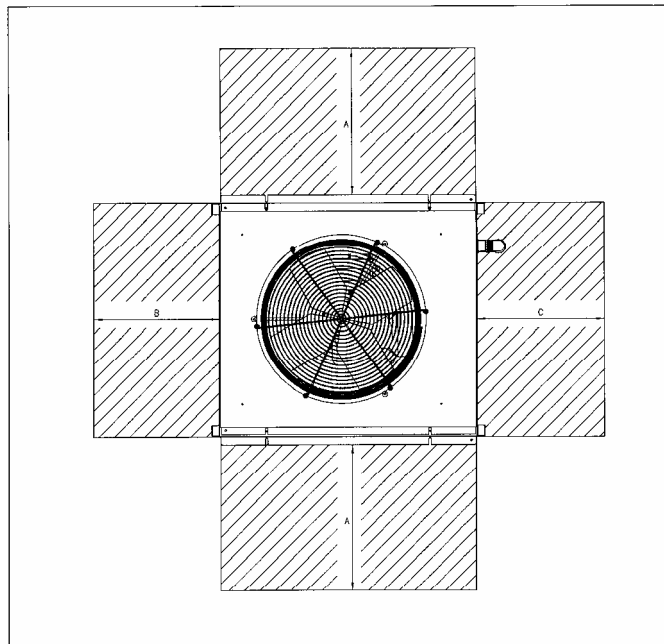

Remarks: Minimum vertical clearance required above the unit is side clearance (A=950mm) should be doubled if two units are installed side by side, or when there are obstructions such as walls.

Model	A	B	C
MAC075 – 125B MAC075 – 125BR	950mm	900mm	900mm

Servicing and Maintenance

Servicing

Servicing or maintenance of these unit must be carried out by experienced personnel with specific training in refrigeration. Repeated check the safety devices and continuous cycling of control components must be analyzed and corrected before being reset.

The simple design of the refrigeration circuit totally eliminates potential problems during normal unit operation. No maintenance work is needed on the refrigeration circuit as long as the unit is operating normally.

Ease of maintenance has been taken into consideration during the design stage such that the unit is easily accessible for servicing and maintenance. By accessing from the front panel of the bottom compartment, servicing and maintenance operation can be done easily. The electrical components are especially easy to access since it is located in the terminal box at the front panel.

Under normal circumstances, these chiller require only a check and cleaning of air intake through the coil surface only. These can be done monthly or quarterly depending on the surrounding where the units are installed.

When the surrounding is very oily or dusty, then the coils must be regularly cleaned by a qualified air conditioner service technician to ensure sufficient cooling capacity and efficient unit operation. The normal life span might be shortened if no proper service is provided.

Maintenance

For consistent performance and durability, always conduct proper and regular maintenance to the unit.

For prolong period of operation time, the heat exchanger will become dirty impairing its effectiveness and reducing the performance of the air conditioner. Consult your local dealer about the cleaning of the heat exchanger.

No major maintenance or servicing needed for the internal water circuit in the bottom compartment except the water pump failure. It is advised that regular check on the filter to be conducted and change the water filter if the filter is dirty or choked.

Always check the water level in the system, in order to protect the moving components in the hydraulic kit from over heating and excessive wear.

Troubleshooting

When any malfunction is occurred, immediately switch off the power supply to the unit, and contact the local dealer, if necessary. Some simple trouble shooting tips are given below.

SYMPTOMS	POSSIBLE CAUSES	REMEDIAL ACTION
1. Compressor does not start	<ul style="list-style-type: none"> • No power supply. • Fuses blown or automatic circuit breakdown open. • Defective contactor or coil. • Unit is stopped because a safety has tripped. • Loose wires. • Compressor faulty. 	<ul style="list-style-type: none"> • Check power supply. • Look for short circuit or grounded wires in motor windings. Replace fuses and reset circuit breakers when the fault has been corrected. Check tightness and soundness of all electrical connections. • Repair or replace. • Determine the type of safety shut down and correct the default before the unit is restarted. • Check wire connections and tighten terminal screws. • Contact local dealer.
2. Fan does not work	<ul style="list-style-type: none"> • No power supply. • Fan motor faulty. 	<ul style="list-style-type: none"> • Check power supply. • Contact local dealer.
3. Air conditioner does work, but insufficient cooling.	<ul style="list-style-type: none"> • Thermostat setting too high. • Condenser coil dirty. • Obstacle blocking air inlet or outlet of the unit. • Insufficient refrigerant in the system. • Improper water flow rate. • Water in the system is contaminated. 	<ul style="list-style-type: none"> • Reset thermostat • Contact local dealer. • Remove the obstacle. • Contact local dealer. • Contact local dealer. • Contact local dealer.

Troubleshooting with Microprocessor

(Not Include Carel Controller)

Symptoms	Possible Causes	Remedial Action
1. PCB display 'CO'	<ul style="list-style-type: none"> Compressor thermal relay tripped Terminal loose 	<ul style="list-style-type: none"> Reset the thermal relay and carefully monitor unit operation when it is restarted Tighten terminal screws.
2. PCB display 'PO'	<ul style="list-style-type: none"> Pump thermal relay tripped Terminal loose 	<ul style="list-style-type: none"> Reset the thermal relay and carefully monitor unit operation when it is restarted. Tighten terminal screws
3. PCB display 'FL'	<ul style="list-style-type: none"> Flow switch connection loose Water volume too low Wrong direction of water flow 	<ul style="list-style-type: none"> Tighten terminal screws Add water into the system Interchange power input phase
4. PCB, display 'HP'	<ul style="list-style-type: none"> Discharge pressure too high Overcharge Coil dirty Condenser fan does not work Expansion valve stuck in open position 	<ul style="list-style-type: none"> Reset the pressure switch and observe the unit operation when it is restarted Contact local dealer Clean the coil with chemical detergent Contact local dealer Replace it
5. PCB display 'LP'	<ul style="list-style-type: none"> Suction pressure too low Undercharge Gas leak Water flow rate too low 	<ul style="list-style-type: none"> Reset the pressure switch and observe the unit operation when it is restarting. Contact local dealer Contact local dealer Adjusting the flow rate
6. PCB display 'E3'	<ul style="list-style-type: none"> Antifreeze protection activated. Water flow rate too low Bubble in the heat exchanger 	<ul style="list-style-type: none"> Check the temperature setting Adjusting the flow rate Increase the water volume

Schematic Diagram

Refrigerant and Hydraulic Circuit Diagram

Cooling Version

Model : MAC040 ~ 058A

M4AC040 ~ 058AE

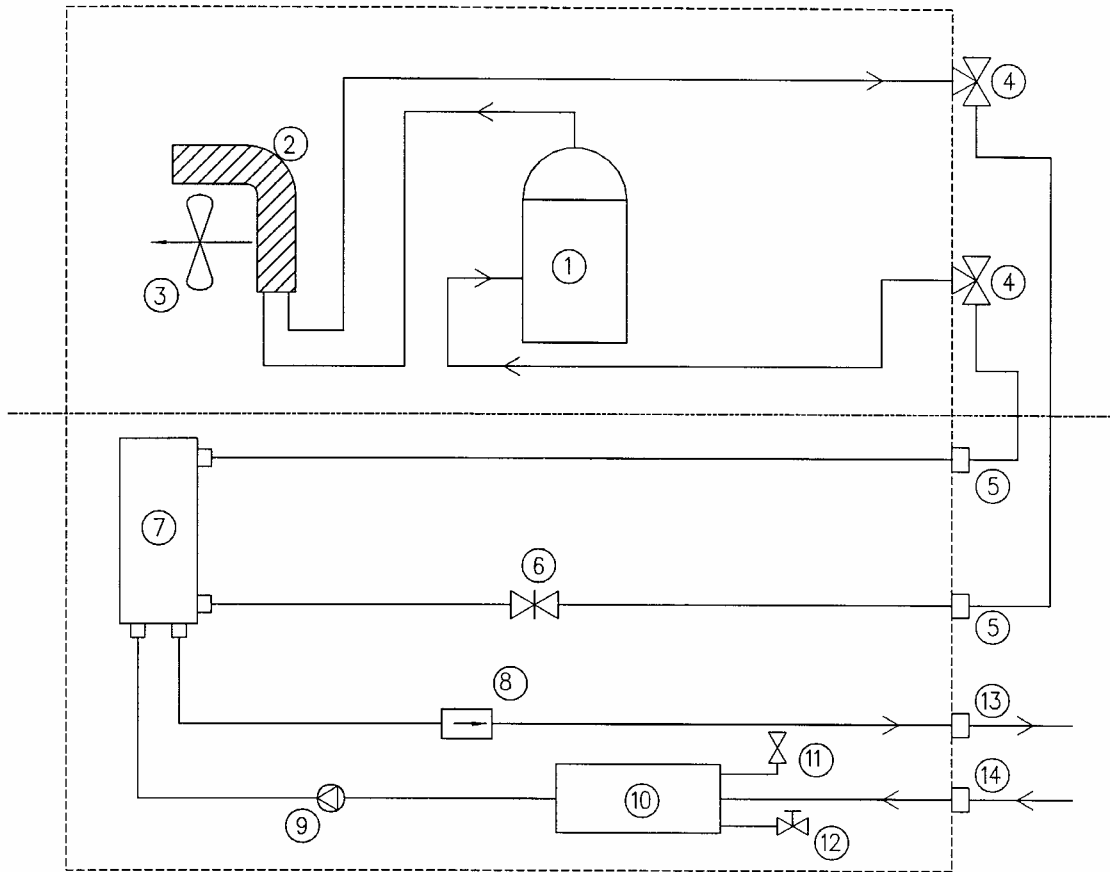

1. COMPRESSOR	8. FLOW SWITCH
2. HEAT EXCHANGER (CONDENSER)	9. WATER PUMP
3. MOTOR FAN	10. WATER STORAGE TANK
4. THREE WAY VALVES WITH FLARE JOINT	11. AUTO AIR VENT
5. FLARE JOINT	12. DRAIN VALVE
6. THERMOSTATIC EXPANSION VALVE	13. WATER OUTLET
7. BRAZED PLATE HEAT EXCHANGER	14. WATER INLET

Refrigerant and Hydraulic Circuit Diagram
Heat Pump Version
Model : MAC040 ~ 058AR
M4AC040 ~ 058ARE

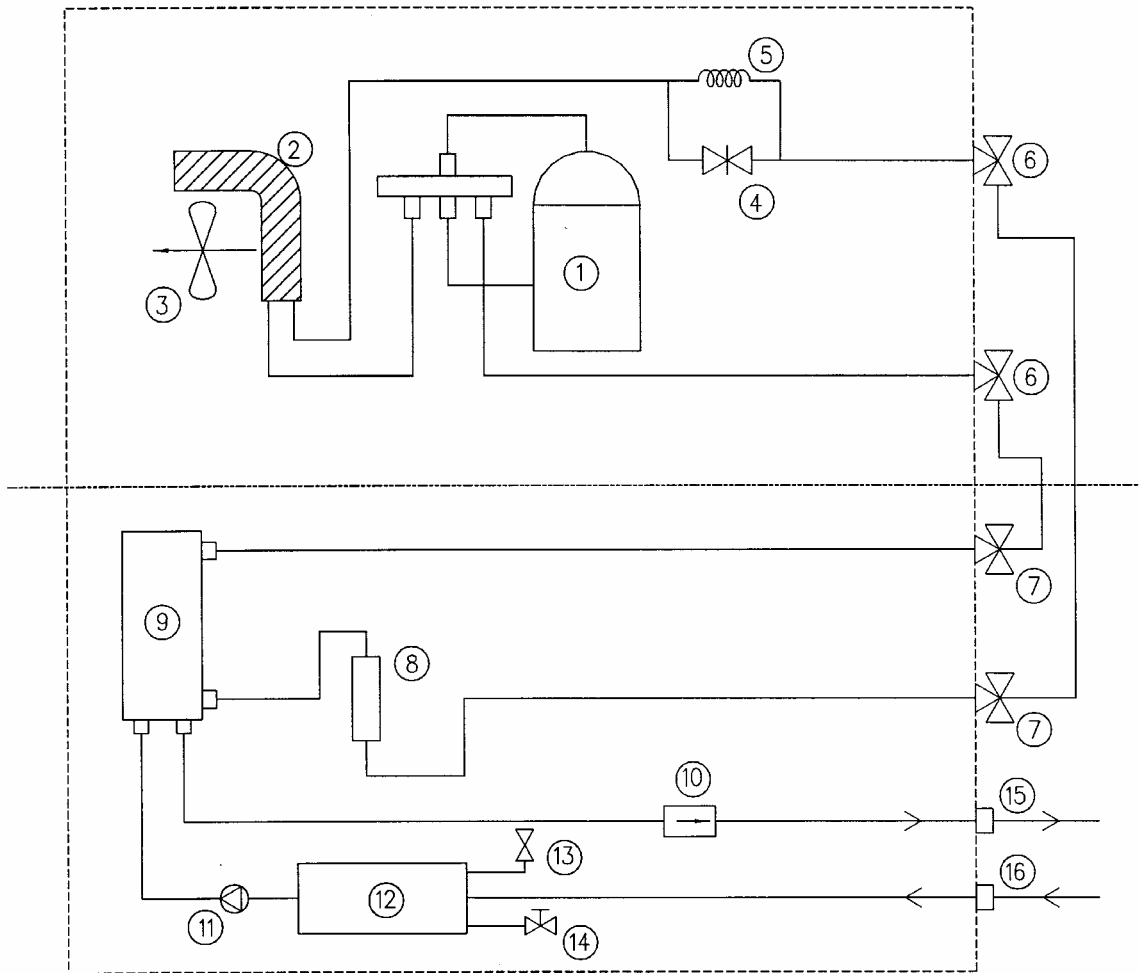

1. COMPRESSOR	9. BRAZED PLATE HEAT EXCHANGER
2. HEAT EXCHANGER (CONDENSER)	10. FLOW SWITCH
3. MOTOR FAN	11. WATER PUMP
4. THERMOSTATIC EXPANSION VALVE	12. WATER STORAGE TANK
5. CAPILLIARY TUBE	13. AUTO-AIR VENT
6. THREE WAY VALVE WITH FLARE JOINT	14. DRAIN VALVE
7. FLARE JOINT	15. WATER OUTLET
8. CHARGE COMPENSATOR	16. WATER INLET

**Cooling (Schematic Diagram)
(MAC075B ~ 125B)**

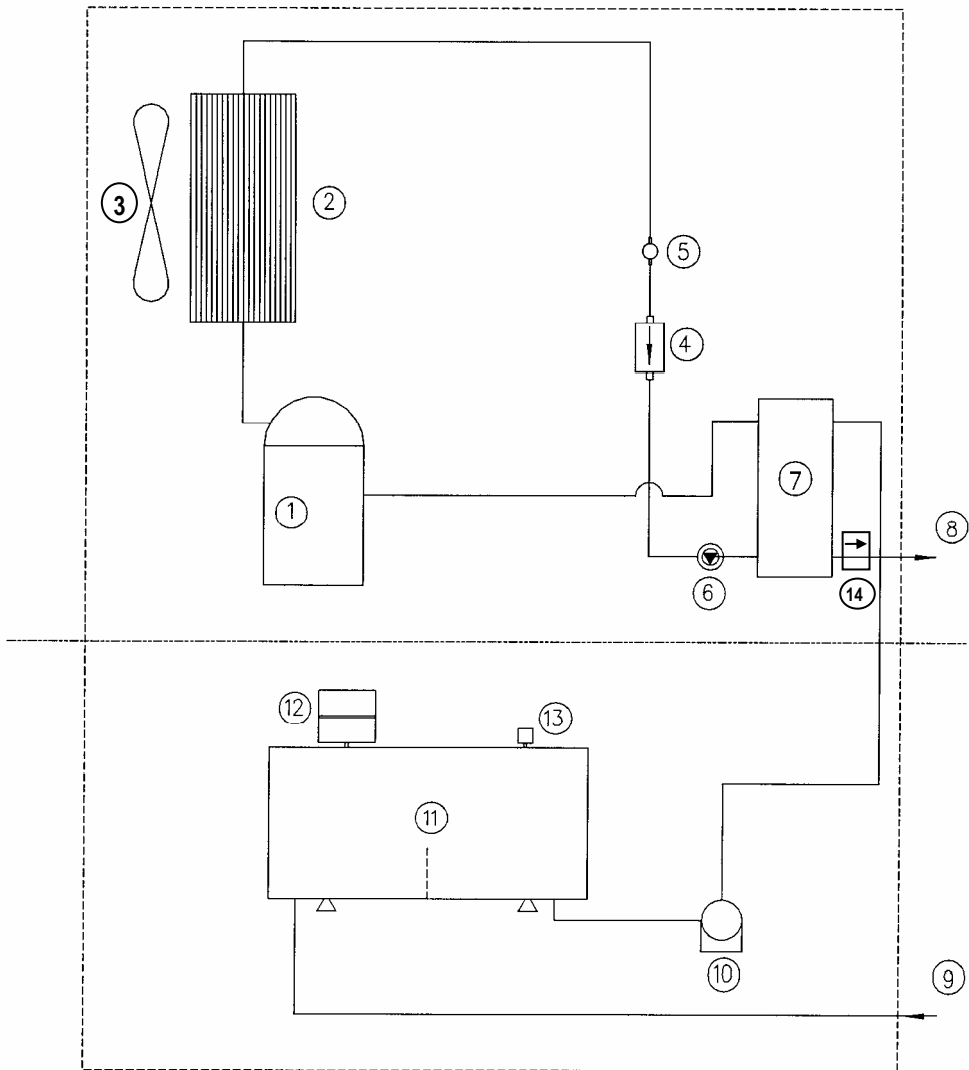

1. SCROLL COMPRESSOR	8. CHILLED WATER OUT
2. OUTDOOR HEAT EXCHANGER	9. CHILLED WATER IN
3. FAN MOTOR	10. PUMP
4. FILTER DRIER	11. WATER STORAGE TANK
5. SIGHTGLASS	12. EXPANSION TANK
6. THERMOSTATIC EXPANSION VALVE	13. AUTO-AIRVENT
7. BPHE	14. FLOW SWITCH

**Heat Pump (Schematic Diagram)
(MAC075 ~ 125BR)**

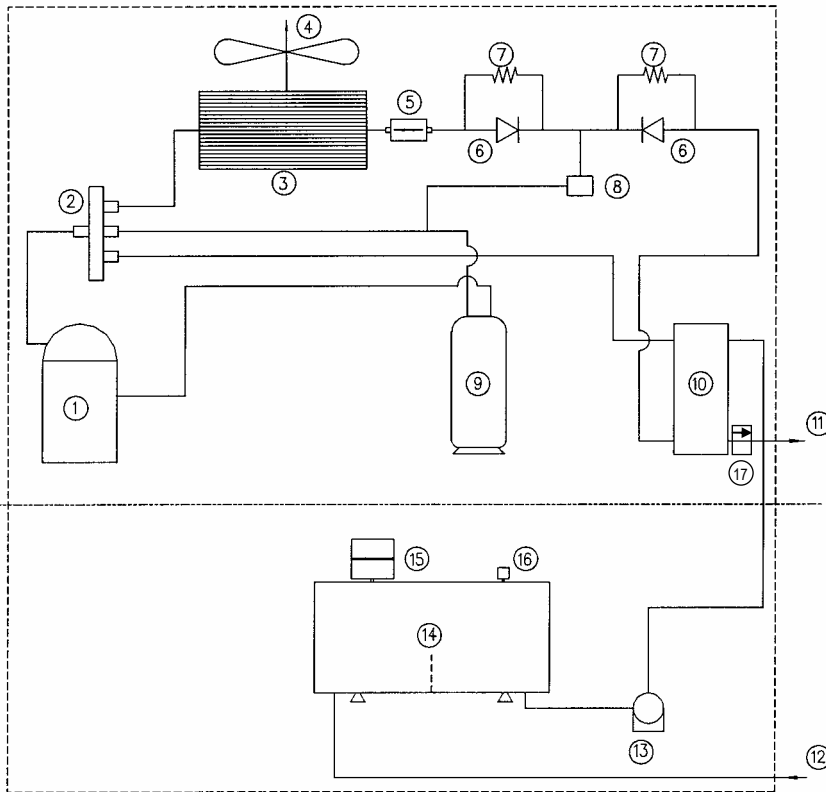

1. SCROLL COMPRESSOR	9. SUCTION ACCUMULATOR
2. 4 WAY VALVE	10. BPHE
3. HEAT EXCHANGER	11. CHILLER WATER OUT
4. FAN MOTOR	12. CHILLER WATER IN
5. FILTER DRIER	13. PUMP
6. CHECK VALVE	14. WATER STORAGE TANK
7. CAP TUBE	15. EXPANSION TANK
8. DIFFERENTIAL PRESSURE REGULATOR	16. AUTO- AIRVENT
	17. FLOW SWITCH

Refrigerant Circuit Diagram
Model : M4AC075BRE, 100BRE, 125BRE

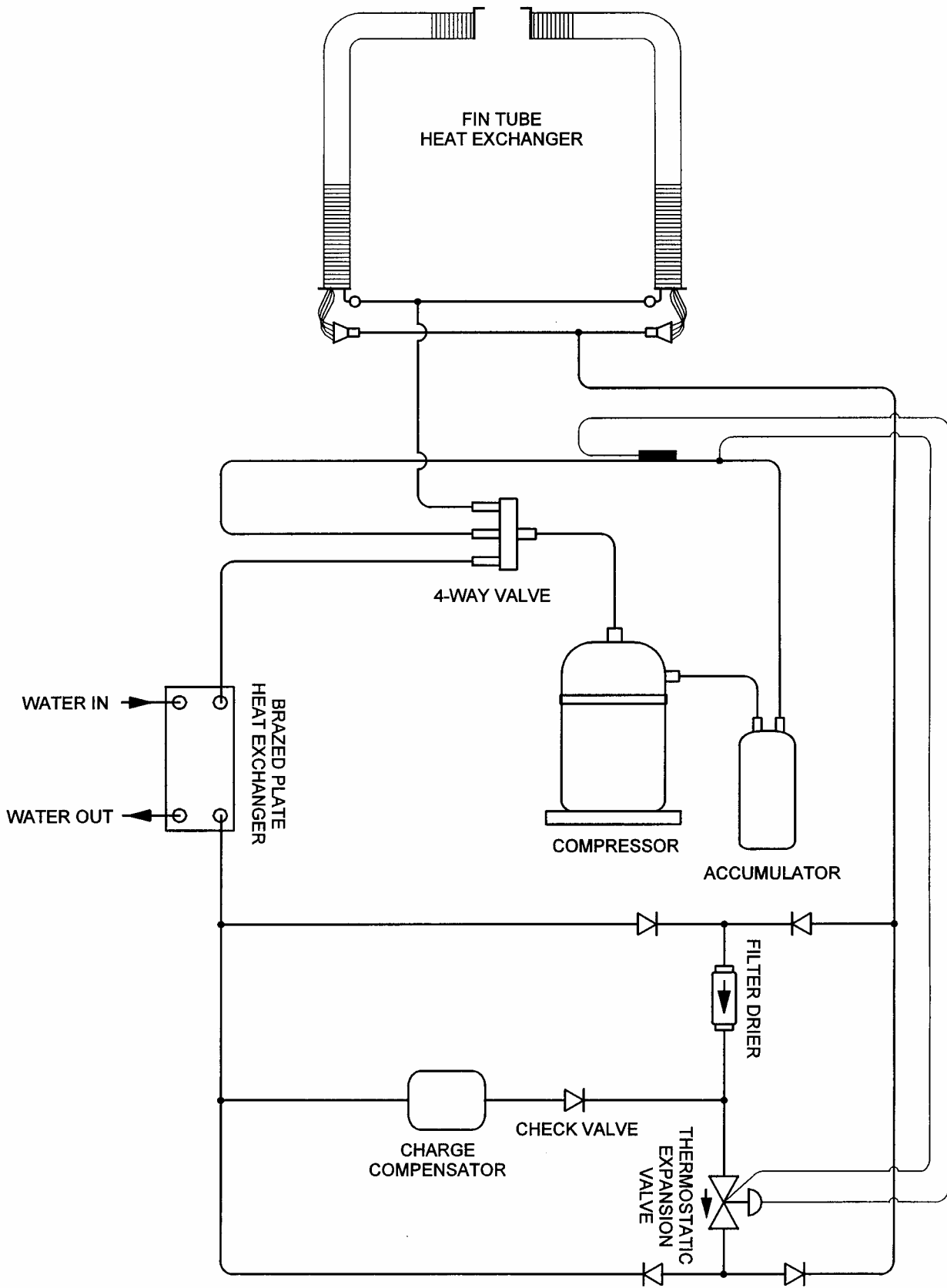

Parts List and Exploded View

Model : MAC/ M4AC040 ~ 058A/AR
(Top Compartment)

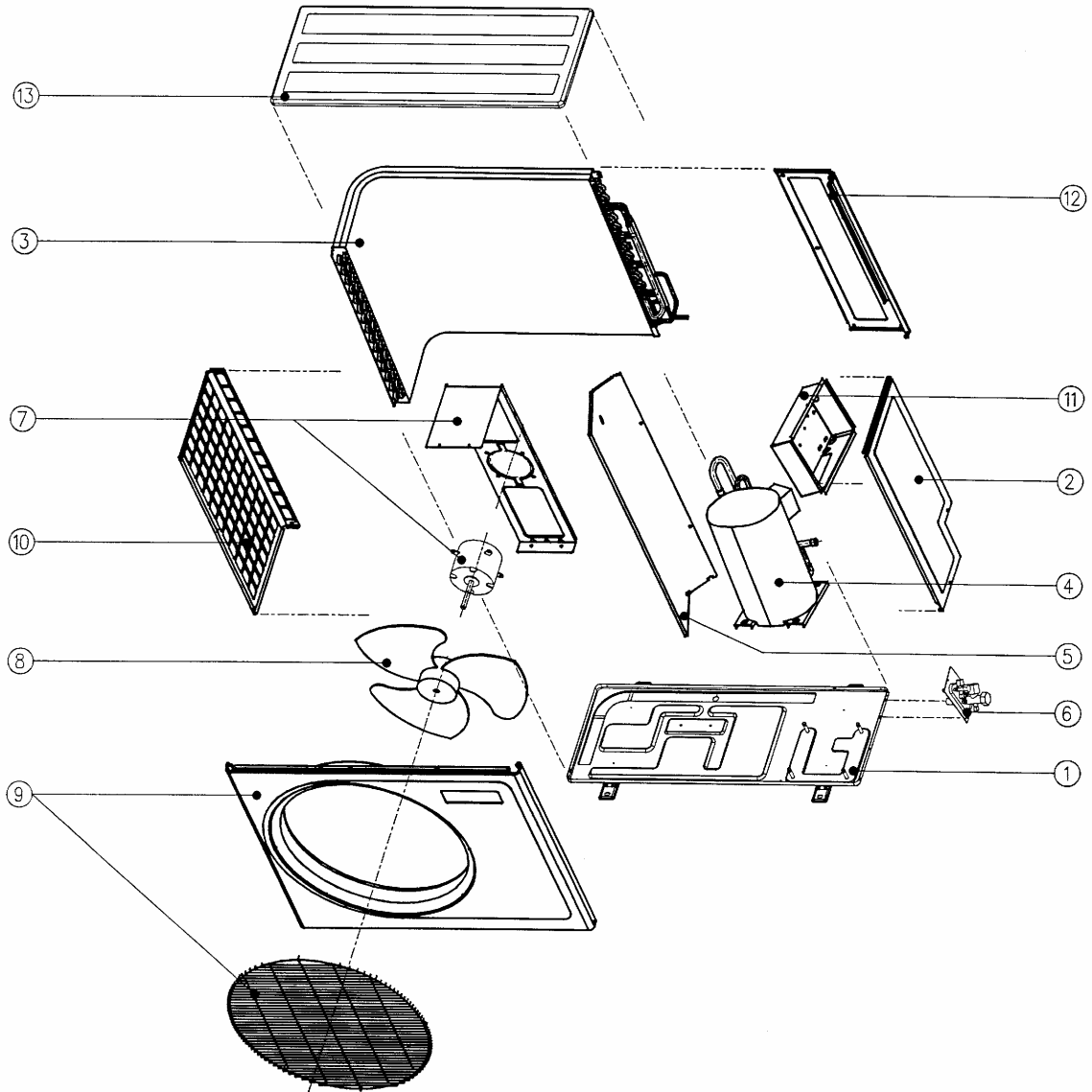

1. BASE PAN ASSY.	8. FAN BLADE
2. ACCESS/SERVICE PANEL	9. FRONT PANEL ASSY.
3. CONDENSER COIL ASSY.	10. SIDE PANEL LEFT
4. COMPRESSOR	11. TERMINAL BOX ASSY.
5. PARTITION PANEL	12. BACK PANEL
6. VALVE PLATE ASSY.	13. TOP PANEL
7. FAN MOTOR & BRACKET ASSY.	

(Bottom Compartment)

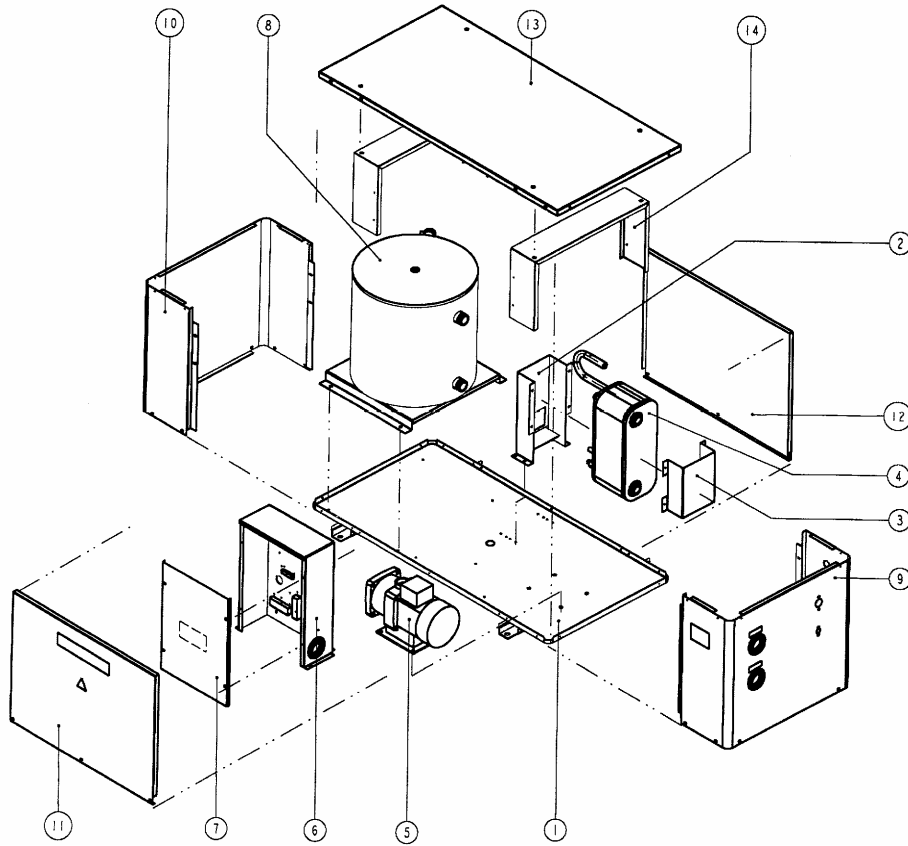

1. BASE PAN ASSY.	8. WATER STORAGE TANK
2. BPHE BRACKET	9. SIDE PANEL RIGHT
3. BPHE CLAMP	10. SIDE PANEL LEFT
4. BRAZED PLATE HEAT EXCHANGER	11. FRONT PANEL
5. WATER PUMP	12. REAR PANEL
6. TERMINAL BOX ASSY.	13. TOP PANEL
7. TERMINAL BOX COVER	14. SUPPORT STRUCTURE

Model : MAC/ M4AC075 ~ 125B/BR

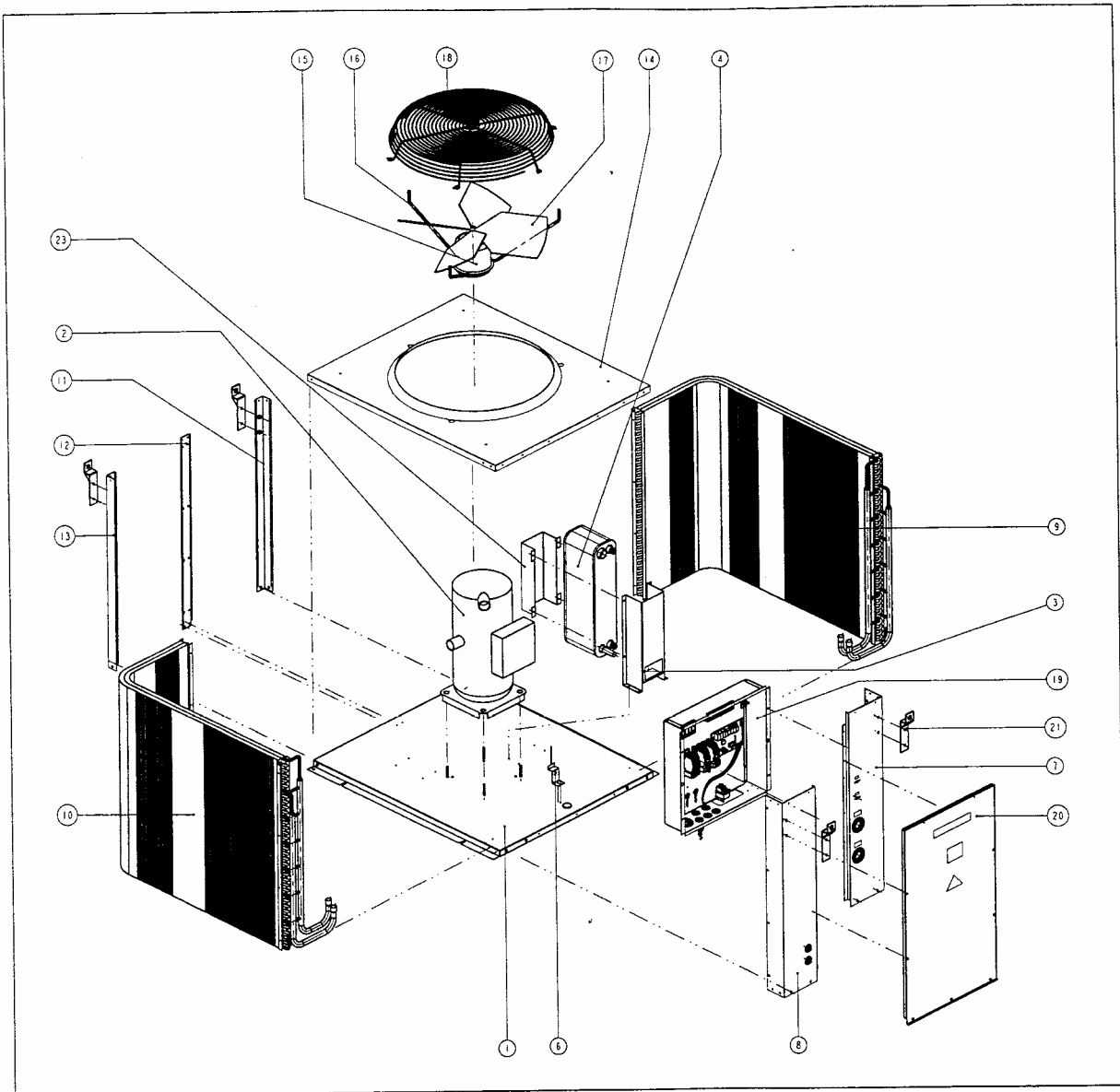

1. ASSY. BASE PAN	13. ASSY. STRUCTURE BACK RIGHT
2. SCROLL COMPRESSOR	14. PLATE. ORIFICE
3. BRACKET BPHE	15. FAN MOTOR
4. ASSY. BPHE	16. BRACKET FAN MOTOR
6. CLAMP TUBE	17. FAN BLADE
7. ASSY. MAIN STRUCTURE FRONT RIGHT	18. FAN GUARD
8. ASSY. MAIN STRUCTURE FRONT LEFT	19. ASSY. CONTROL BOX
9. ASSY. MAIN COIL RIGHT	20. ASSY. FRONT PANEL
10. ASSY. MAIN COIL LEFT	21. SUPPORT HOST BRACKET
11. ASSY. STRUCTURE BACK RIGHT	23. CLAMP BPHE
12. STRUCTURE. COIL	

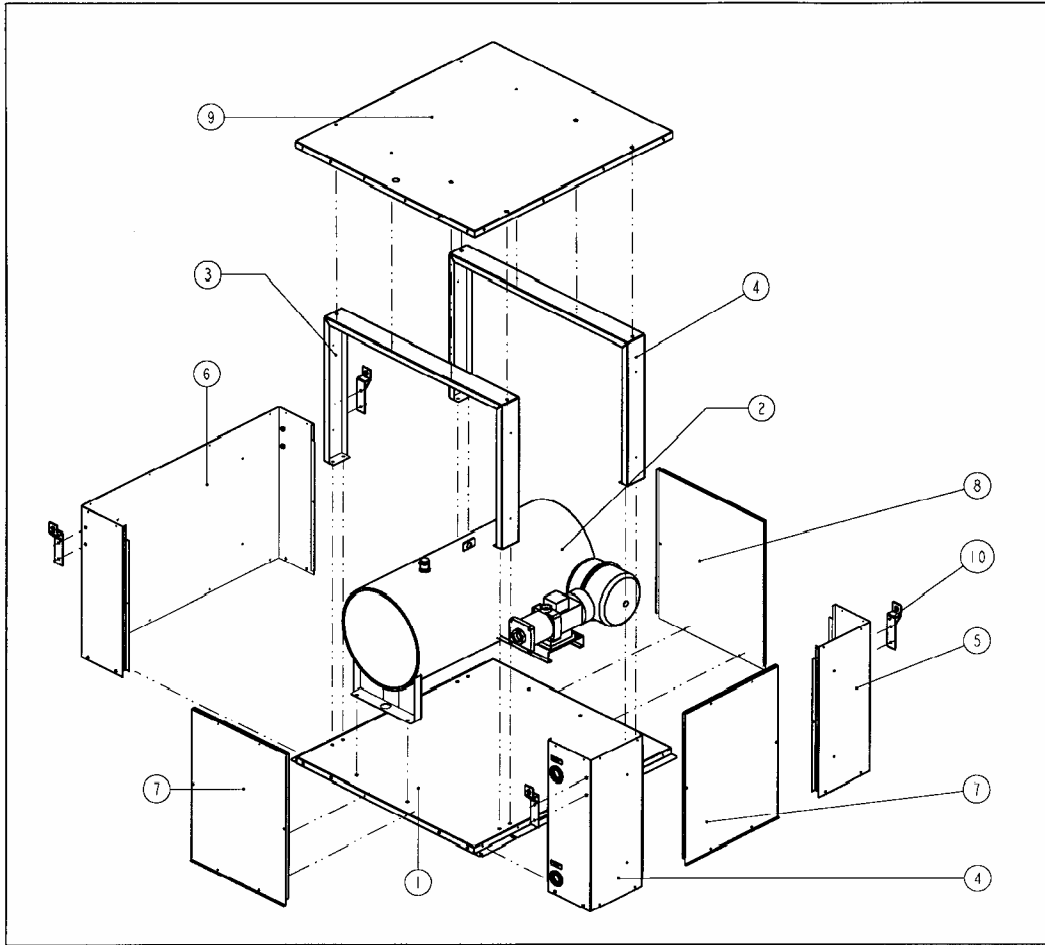

1. ASSY. BASE PAN H	6. ASSY. PANEL SIDE LEFT H
2. ASSY. WATER STORAGE TANK	7. PANEL. FRONT SIDE H
3. ASSY. SUPPORT PILAR H	8. PANEL REAR H
4. ASSY. MAIN STRUCT. FRONT RIGHT	9. PANEL TOP H
5. ASSY. STRUCTURE REAR RIGHT H	10. ASSY. SUPPORT HOISTING BRACKET

