

## HS6 SERIES UNITS

### I - INTRODUCTION

The HS6 has been in production since 1966 and is currently available in nominal 6, 7-1/2 and 11 ton models. It was designed for industrial and commercial applications. The unit mates to a C3 evaporator coil (which is built with an expansion valve). The unit can be applied to an RL-45 Relay Control Center. A Low Ambient Control Kit is available (LB-80249BB).

Figure 1 shows an encased view of the HS6-853V and HS6-953 models.

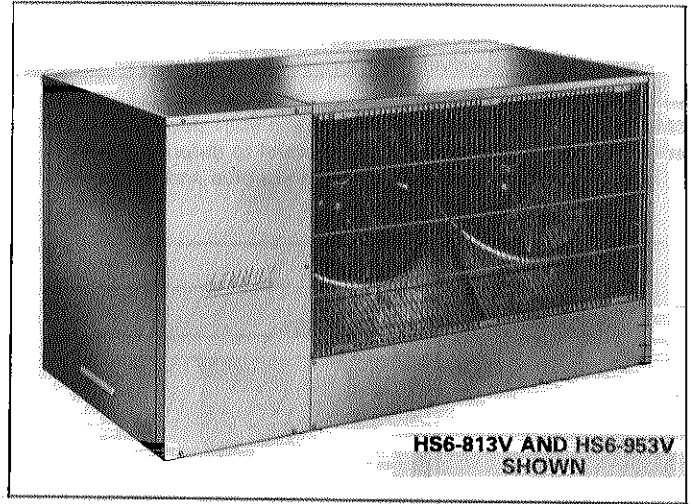

FIGURE 1

### II - UNIT INFORMATION

#### A - Specifications

Model No.		HS6-813V	HS6-953V	HS6-1353
Condenser	Net face area (sq. ft.)	12.5	12.5	13.33
	Tube diameter (in.)	1/2	1/2	1/2
	Number of rows	3	3	4
	Fins per inch	10	13	13
Condenser Fans (2)	Diam. (in) & No. of blades	(2) 22 — 4	(2) 22 — 4	(2) 26 — 5
	Motor hp	(2) 1/2	(2) 1/2	(2) 1/2
	Cfm (factory set)	6700	6500	7400
	Rpm (factory set)	1045	1045	780
	Watts (factory set)	960 (total)	960 (total)	1180
	Refrigerant-22 (furnished)	holding charge	holding charge	holding charge
	Liquid line connection O.D. (in.)	5/8 (sweat)	5/8 (sweat)	3/4 (sweat)
	Suction line connection O.D. (in.)	1-1/8 (sweat)	1-3/8 (sweat)	1-3/8 (sweat)
	Net weight (lbs) (1 pkg.)	650	675	1160

#### B - Air Pattern

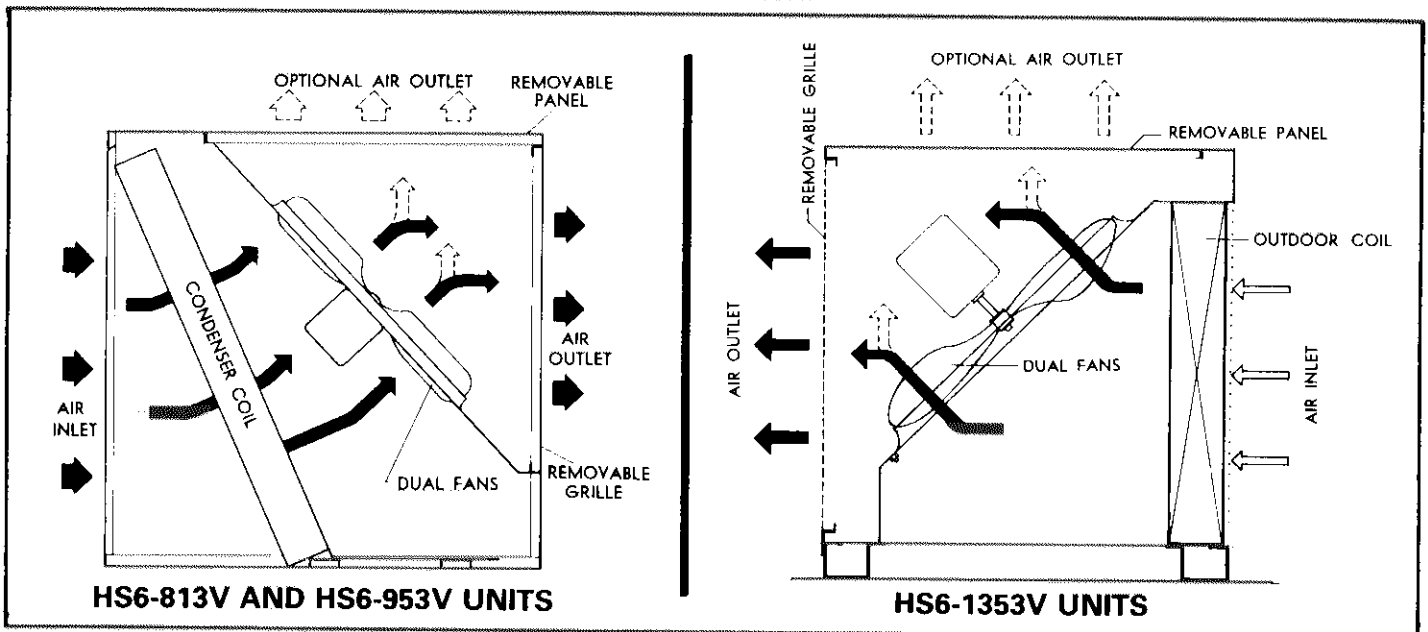

### C - Electrical Data

Model No.		HS6-813V		HS6-953V		HS6-1353V		
Line voltage data (60 Hertz — 3 phase)		208/240V	440/480V	208/240V	440/480V	208/240V	440/480V	550/600V
Compressor	Full load amps	22.1	11.1	32.3	14.6	42.8	20.6	16.4
	Power factor	.85	.85	.85	.85	.85	.85	.85
	Locked rotor amps	129.0	65.3	185.0	93.0	240.0	128.0	92.0
Condenser fan motors	Full load amps	6.0 (total)	*3.0 (total)	6.0 (total)	*3.0 (total)	6.8 (total)	*3.4 (total)	*2.7 (total)
	Locked rotor amps	24.0 (total)	*12.0 (total)	24.0 (total)	*12.0 (total)	14.2 (total)	7.1 (total)	4.6 (total)
†Minimum circuit ampacity		40.0	18.9	50.5	23.2	64.3	30.7	24.4

\*Motors are rated at 230V, FLA shown is with step down transformer.

†Refer to National Electrical Code manual to determine wire, fuse and disconnect size requirements.

NOTE — Extremes of operating range are plus and minus 10% of line voltage.

### D - Dimensions

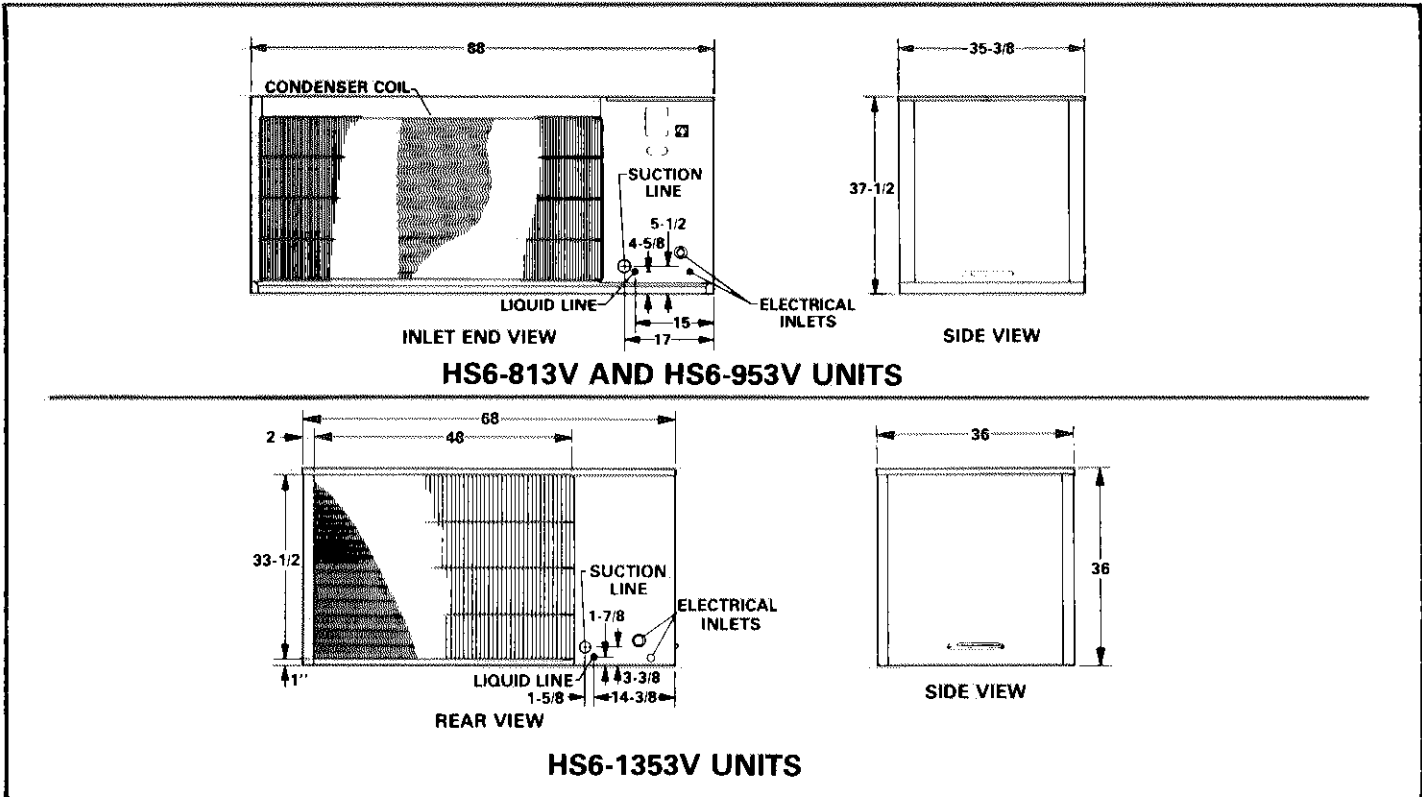

### III - REFRIGERANT SYSTEM

The suction and discharge service valves are located at compressor. See Figure 2. The gauge ports on the service valves can be shut off by backseating the valves. Open valve one turn off back seat to record pressure at gauge manifold.

The HS6 uses a liquid level indicating valve for ease in charging:

- 1 - Cover the condenser coil from top to bottom with a piece of cardboard. Attach gauge manifold and then start machine while monitoring system pressure. Slide cardboard out until the head pressure reads 300 psig.
- 2 - The liquid level indicating valve is situated at a point in the condenser coil where the refrigerant should be totally in the liquid state. Open the indicating valve and observe the flow. A solid uninterrupted flow of liquid should be emitted for a 10 to 15 second period. If there are any intermittent spurts of liquid, add additional refrigerant until only liquid is emitted for the required time. See Figure 3.

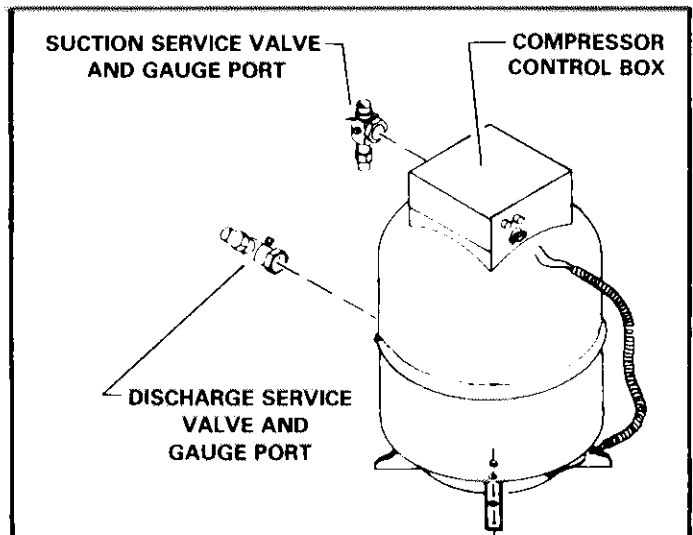
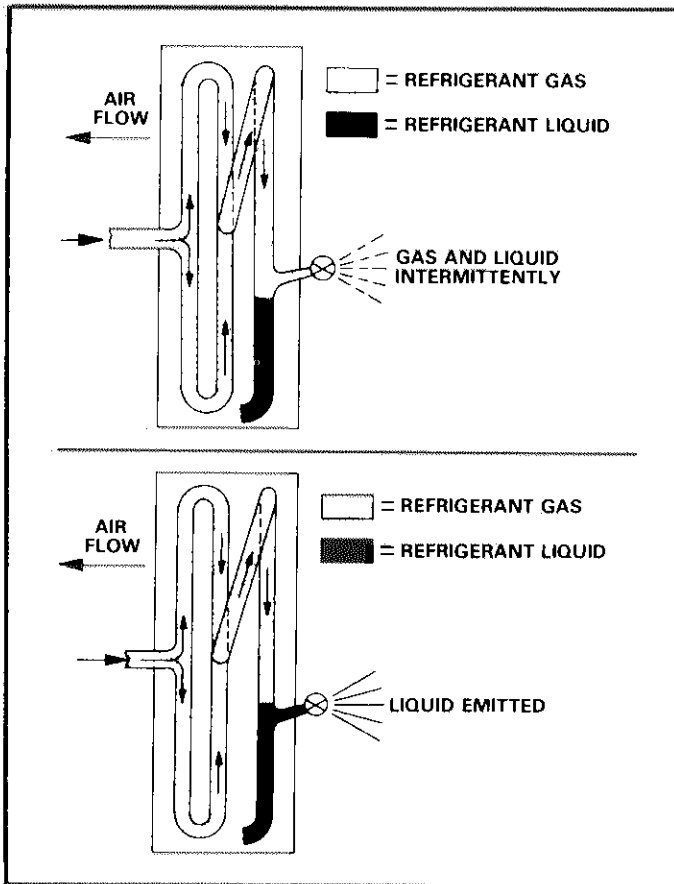

FIGURE 2



**FIGURE 3**

If there is a suspected overcharge, remove refrigerant from system until there is intermittent spurts of gas and liquid at the valve. Add refrigerant until only liquid is emitted for the required time.

## IV - COMPONENTS

Figures 4 and 5 show exploded views of the HS6.

### A - Control Box (Figure 6)

#### 1 - Timed Off Control

Prevents compressor short cycling and allows time for system pressures to equalize. Initially the control delays compressor operation for 20 seconds. It must run through a 5 minute cycle before it resets. If the compressor operates less than 5 minutes, the Timed Off Control will run through the remaining time plus 20 seconds on the next demand.

#### 2 - Control Relay

Upon a cooling demand the control relay energizes the Compressor Contactor.

#### 3 - Compressor Contactor

Energizes compressor and condenser fan motors.

### B - L2 Compressor (Figure 7)

The compressor is protected by a series of controls, located in the compressor make-up box, which monitor the system. They shut down the unit during periods of abnormal operating conditions.

#### 1 - Compressor Overloads (3)

These protectors are current sensitive and are intended to

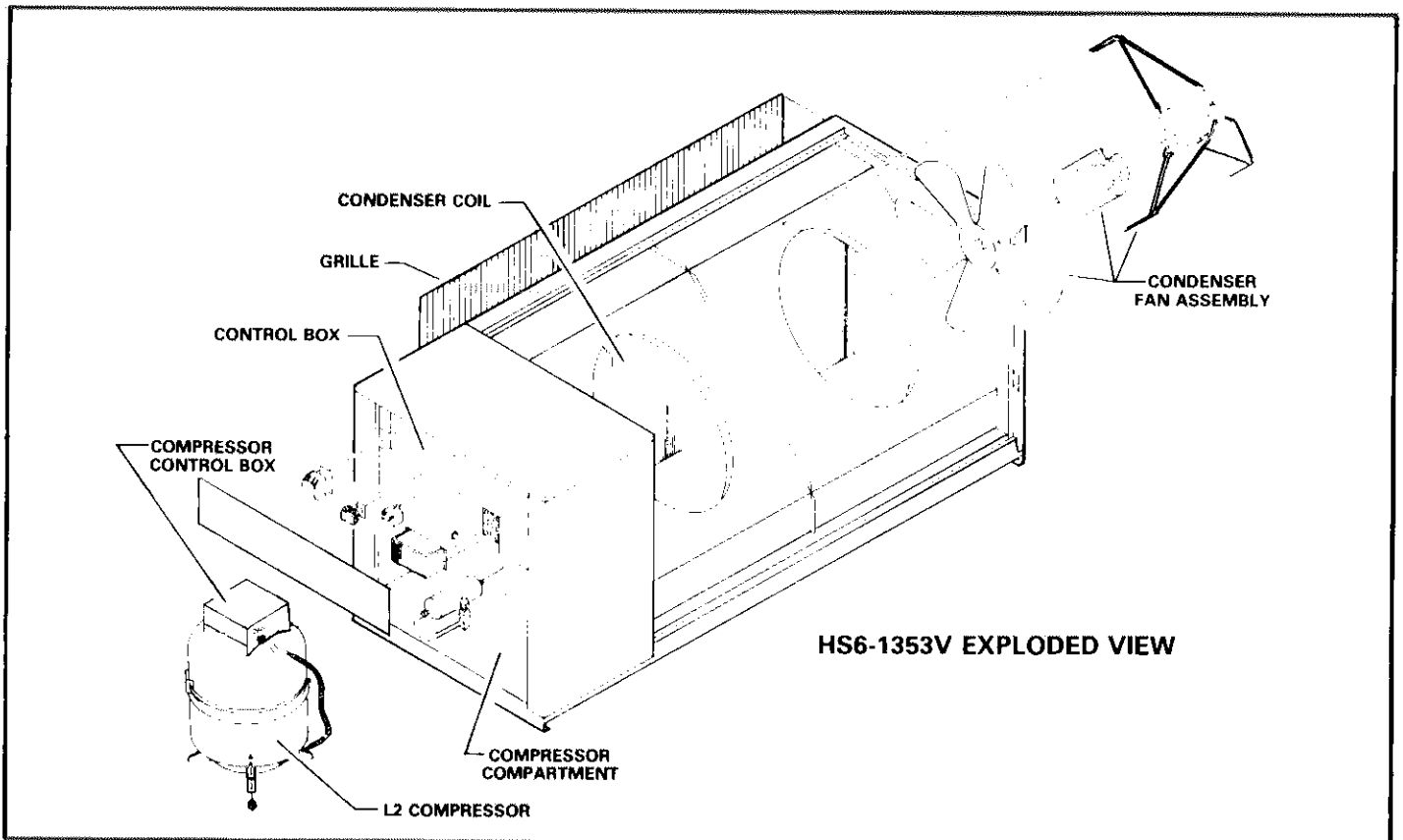

**HS6-1353V EXPLODED VIEW**

**FIGURE 4**

**HS6-853V AND HS6-953V EXPLODED VIEW**

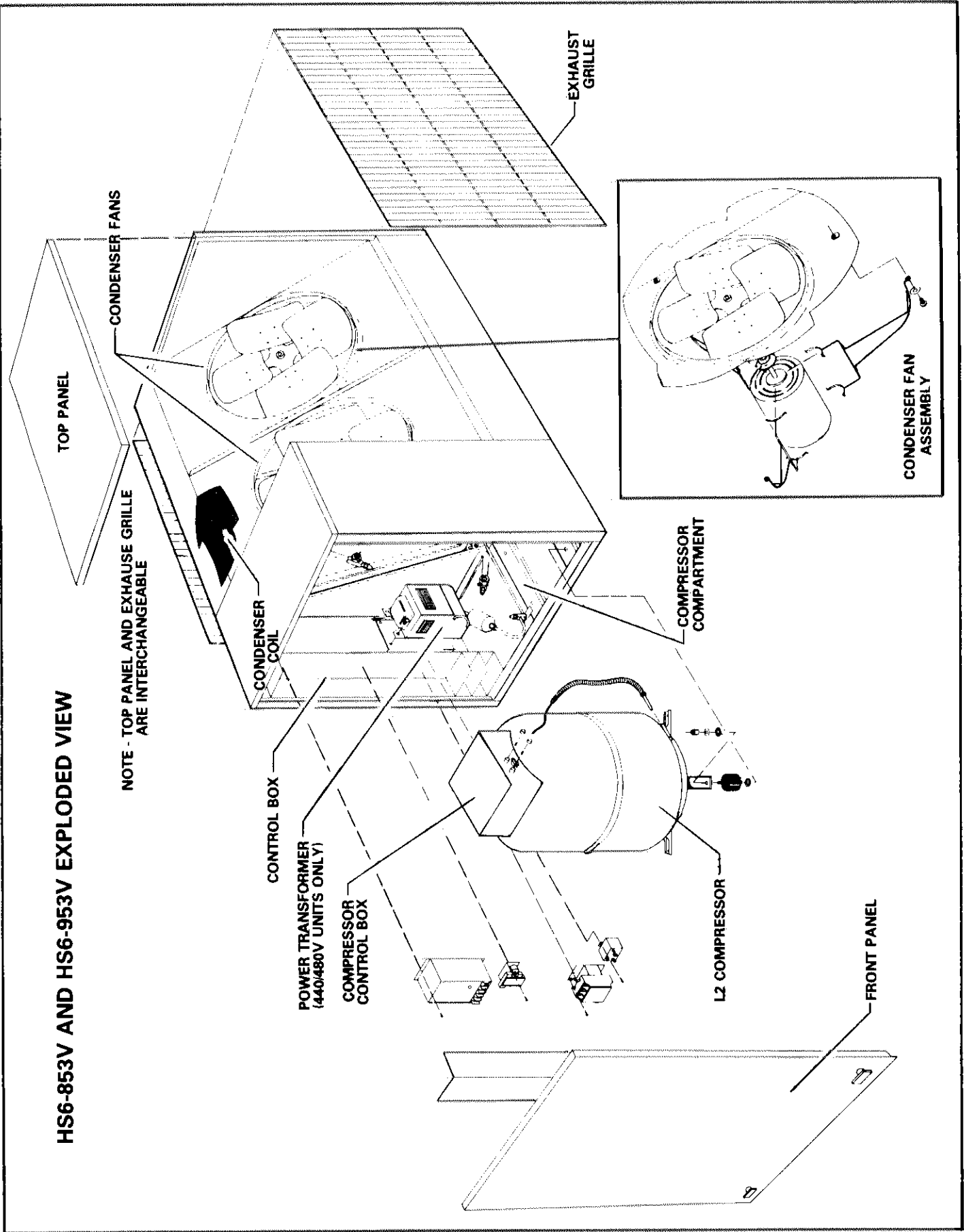

**FIGURE 5**

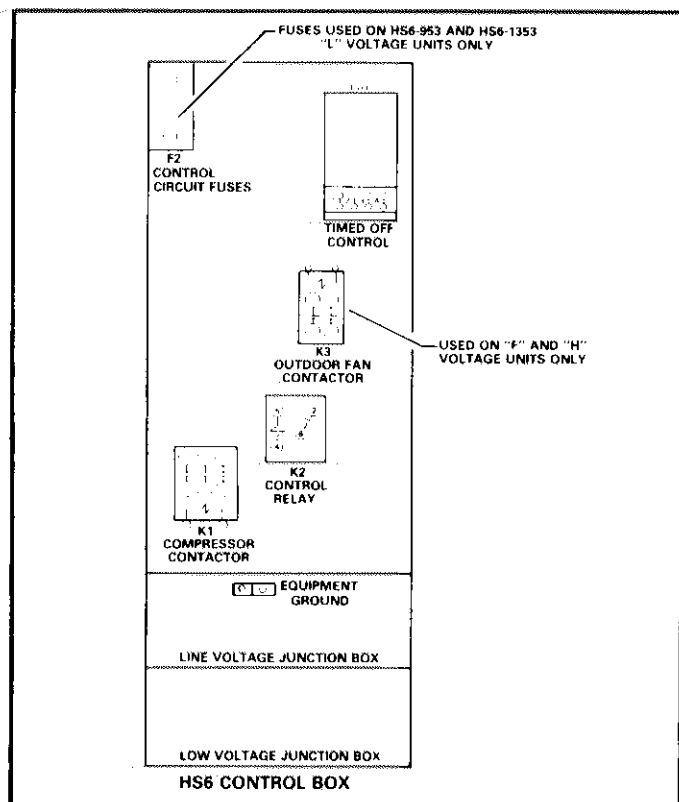

FIGURE 6

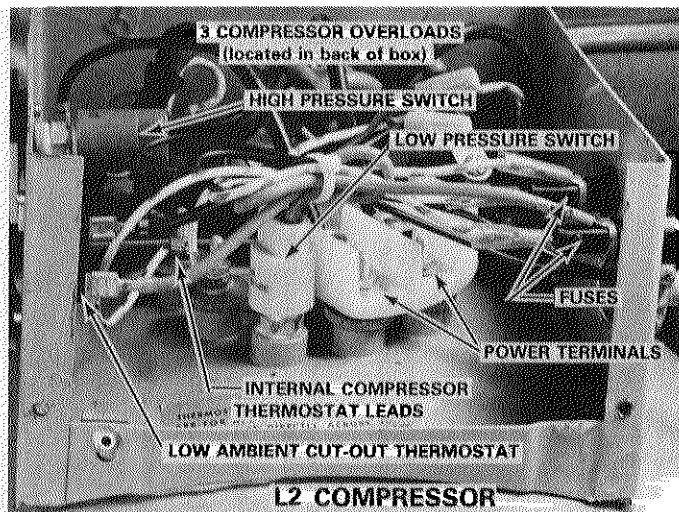

FIGURE 7

protect the compressor motor from single phasing (loose wiring) and locked rotor conditions.

**2 - High Pressure Switch**

Opens control circuit at 410 psig head pressure. Automatically resets.

**3 - Ambient Thermostat**

This thermostat opens control circuit at 22°F ambient and automatically resets at 32°F.

**4 - Low Pressure Switch**

Opens control circuit at 20 psig suction pressure and automatically resets at 50 psig.

**5 - Fuses (2)**

The 3 amp fuses protect the internal thermostat from damage.

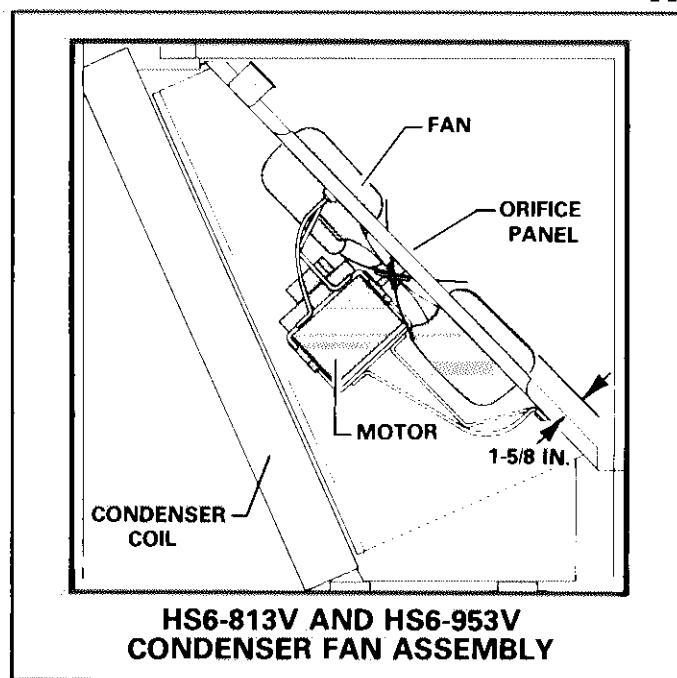

FIGURE 8

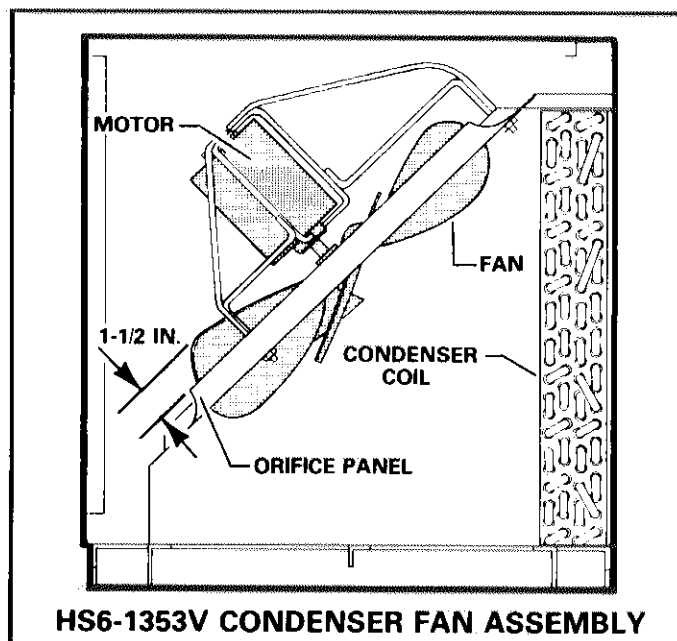

FIGURE 9

**6 - Internal Thermostat**

This consists of 2 inwinding devices which protect the motor windings from overheating. It may take up to an hour for reset once tripped.

**C - Condenser Coil**

Air draws through the coil and is either discharged through the rear or top of unit. See Air Pattern. For fan service access, remove the bolts securing fan assembly. Figures 8 and 9 illustrate the condenser fan and motor assemblies.

**V - SCHEMATIC WIRING DIAGRAM OPERATING SEQUENCE**

Figure 10 shows a typical HS6 sequence of operation when applied to CB3 blower coil and an RL-45 relay control kit.

# HS6 SEQUENCE OF OPERATION

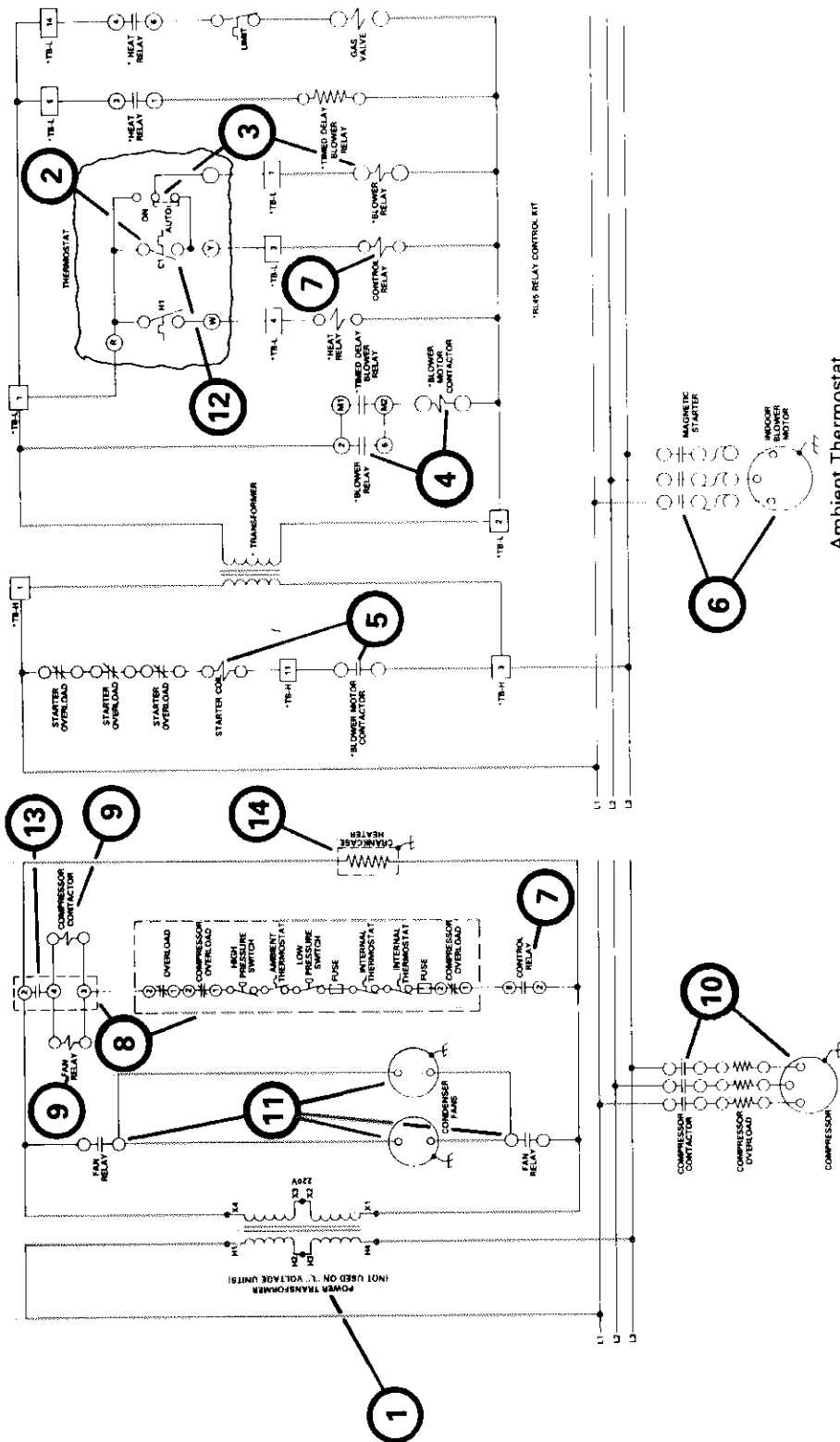

- 1 - On "F" and "H" voltage units, the power transformer is energized continuously. It provides 220 volts for compressor safety circuit and condenser fan motors.
- 2 - The thermostat makes on a cooling demand.
- 3 - If the thermostat is set on "Auto", the Blower Relay is energized.
- 4 - The Blower Relay closes its N.O. contacts to energize the Blower Motor Contactor.
- 5 - In turn the Blower Motor Contactor closes its N.O. contacts to energize the Magnetic Starter.
- 6 - The Magnetic Starter then closes its N.O. contacts to power the Indoor Blower Motor.
- 7 - As the thermostat makes it also energizes the Control Relay. The relay then closes its N.O. contacts.
- 8 - This completes a circuit to the Timed Off Control through the L2 compressor protection circuit:  
Compressor Overloads  
High Pressure Switch

- 9 - On "Y" voltage units it also powers the condenser fan motors.
- 10 - On "Y" voltage units, the Outdoor Fan Contactor closes its N.O. contacts to power the condenser fan motors.
- 11 - As the cooling demand is satisfied, the thermostat cycles off the compressor and condenser fan motors.
- 12 - If the original cycle was less than 5 minutes, the timed off control will wait the remaining time plus 20 seconds on the next cooling demand.
- 13 - Crankcase heater operation is continuous.
- 14 - Crankcase heater operation is continuous.

**NOTE** - On HS6 "L" voltage units, the control circuit is protected by fuses located in the control box.  
Compressor Contactor and Outdoor Fan Contactor ("G" and "F" voltage units only).

FIGURE 10