



installation – operation – maintenance instructions

HS18 SERIES UNITS

LENNOX Industries Inc.

Litho U.S.A.

1 through 5 ton

502,062M

5/90

Supersedes 7/88

UNIT DIMENSIONS

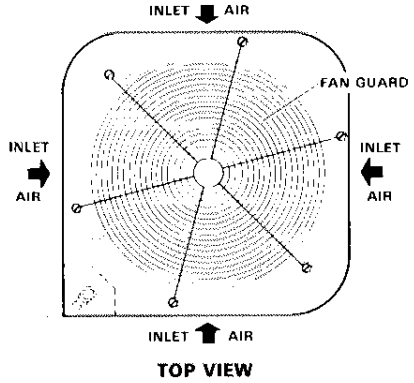

Model No.	A	B	C	D	E	F
HS18-141 HS18-211	26-3/4 in. (680mm)	22-1/4 in. (565mm)	3-5/8 in. (92 mm)	6-7/8 in. (175mm)	3-5/8 in. (92mm)	15 in. (381mm)
HS18-311 HS18-410	28-3/4 in. (730mm)	22-1/4 in. (565mm)	6 in. (152mm)	9-1/2 in. (241mm)	3-5/8 in. (92mm)	15 in. (381mm)
HS18-460	33-9/16 in. (852mm)	28-13/16 in. (732mm)	4-13/16 in. (122mm)	9-5/16 in. (237mm)	4-3/4 in. (121mm)	19-15/16 in. (491mm)

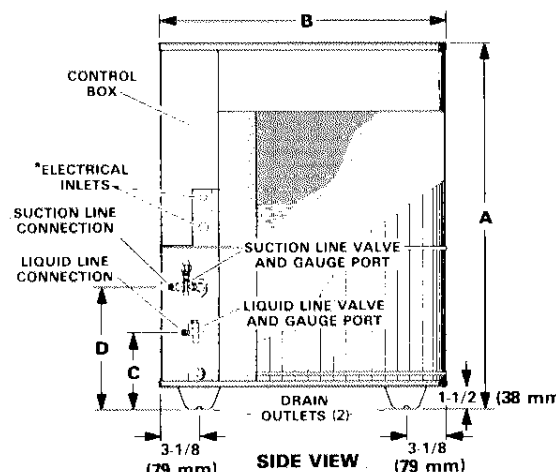

*Electrical inlet is in bottom of control box on HS18-141, -211 & -261.

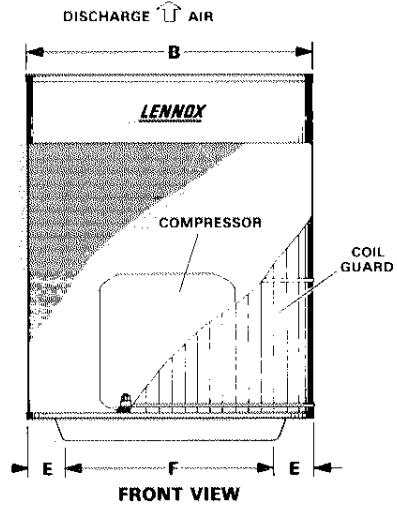

CHECK POINTS

START-UP AND PERFORMANCE CHECK LIST

Job Name _____ Job No. _____ Date _____
 Job Location _____ City _____ State _____
 Installer _____ City _____ State _____
 Unit Model No. _____ Serial No. _____ Serviceman _____
 Nameplate Voltage _____ Amps: _____
 Minimum Circuit Ampacity _____ Supply _____ Condenser Fan _____
 Maximum Fuse Size _____ Compressor _____
 Electrical Connections Tight? Indoor Filter Clean? Indoor Blower RPM _____
 Supply Voltage (Unit Off) _____ S.P. Drop Over Evaporator (Dry) _____
 Condenser Entering Air Temperature _____
 Discharge Pressure _____ Suction Pressure _____
 Refrigerant Charge Checked?

COOLING SECTION

Refrigerant Lines:
 Leak Checked? Properly Insulated?
 Service Valves Backseated? Service Valve Caps Tight?
 Condenser Fan Checked?
 Voltage With Compressor Operating _____

THERMOSTAT

Calibrated? Properly Set? Level?

INSTALLATION

PACKAGE 1 OF 1 CONTAINS

1 - Assembled unit

Check unit for shipping damage. Consult last carrier immediately if damage is found.

These instructions are intended as a general guide and do not supersede local codes. Authorities having jurisdiction should be consulted before installation.

INSTALLATION

The condensing units are designed for expansion valve or RFC Systems. Refer to Engineering Handbook for expansion valve kits, they must be ordered separately.

SETTING THE UNIT

Refer to unit dimensions on Page 1 for sizing mounting slab, platforms or supports.

Slab Mounting

When installing a unit at grade level, install on a level slab high enough above the grade to allow adequate drainage of water. Top of the slab should be located so run-off water from higher ground will not collect around unit.

Roof Mounting

Install the unit a minimum of 4 inches above the surface of the roof. Care must be taken to insure that the weight of unit is properly distributed over roof joists and rafters. Either redwood or steel supports are recommended.

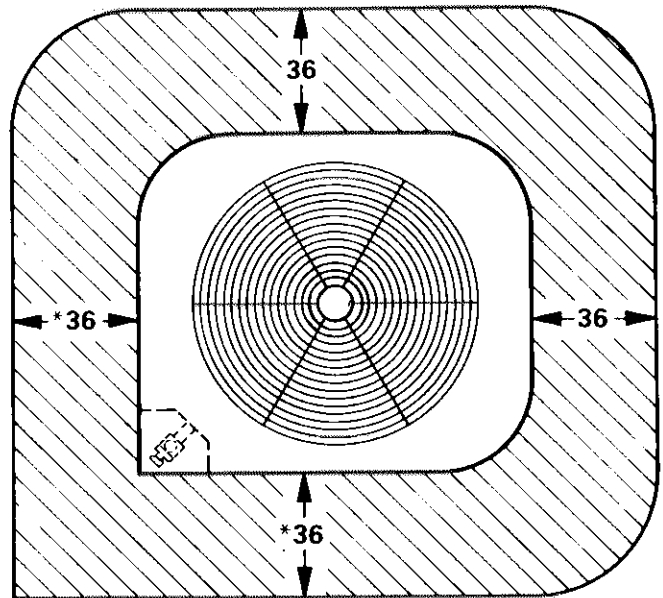

NOTE - 48 inch clearance required on top of unit.

***NOTE** - One side must be 36 inches for service.

Two of the remaining sides may be 12 inches.

ELECTRICAL

Wiring must conform to the National Electric Code (NEC) and local codes. Refer to the furnace or blower/coil instructions for additional wiring application diagrams and refer to the unit rating plate for minimum circuit ampacity and maximum fuse size.

LINE VOLTAGE

To facilitate conduit, holes are provided in cabinet panel that

opens to the control box. Connect conduit to hole in control box with proper conduit fitting.

LOW VOLTAGE

Low voltage connections are made up in the low voltage junction box.

NOTE - A complete unit wiring diagram is located on the inside of the unit control box cover.

NOTE - SEE UNIT WIRING DIAGRAM FOR POWER SUPPLY CONNECTIONS

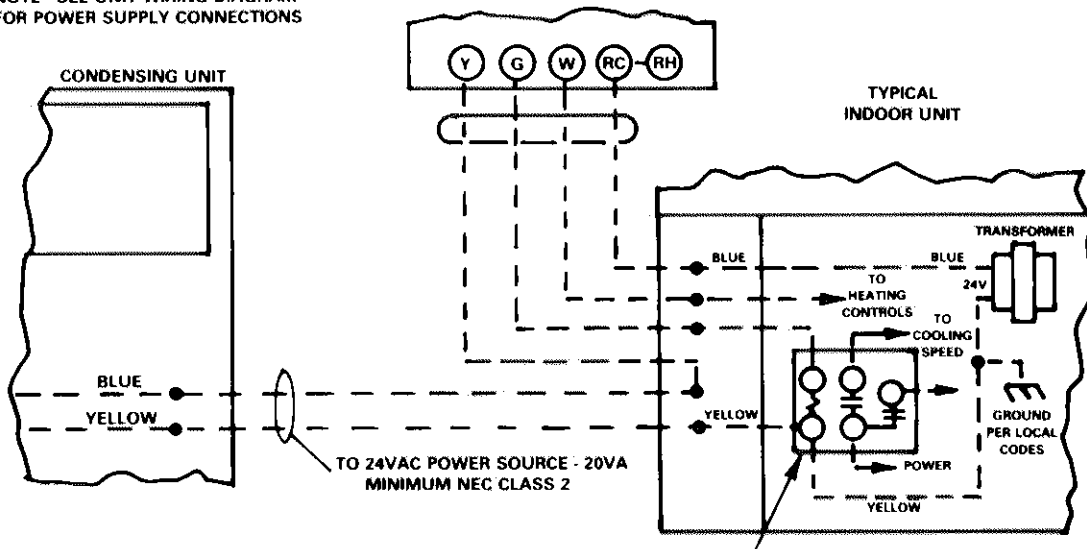

LOW VOLTAGE INSTALLED AT FACTORY
LOW VOLTAGE TO BE INSTALLED
NEC CLASS 2

INDOOR BLOWER RELAY

NOTE - IF INDOOR UNIT IS NOT EQUIPPED WITH BLOWER RELAY, IT MUST BE FIELD PROVIDED AND INSTALLED (P8-3251 OR EQUIVALENT)

CONDENSING UNIT FIELD WIRING DIAGRAM

PLUMBING

Field refrigerant piping consists of liquid and suction lines from the condensing unit (sweat connections) to indoor evaporator coil (flare connections). Use Lennox L10 series sets as shown in the adjacent table or field fabricated refrigerant lines. Refer to "Piping Section" of the Lennox Service Manual for proper size, type and application of field fabricated lines.

Sweat Connection Procedure

- Step 1 - End of refrigerant line must be cut square, round, free from nicks or dents and deburred (I.D. and O.D.)
- Step 2 - Wrap a wet cloth around the valve body and copper tube stub; braze the line set tubing to the valve.
- Step 3 - Quench the joint with water or a wet cloth to prevent possible heat damage to the valve core and opening port.

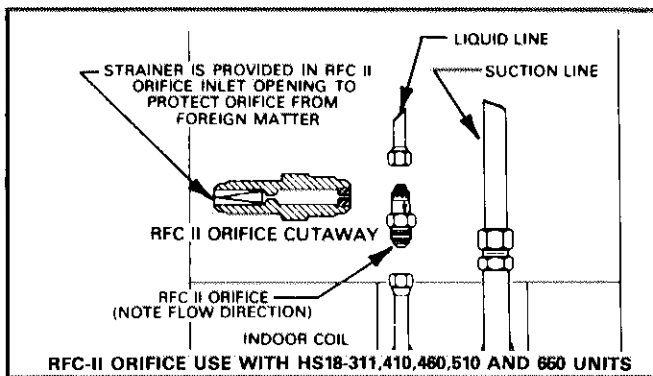

Unit	RFCII Orifice	Liquid Line	Suction Line	L10 Line Sets
HS18-141	76A8801	3/8 in. 10 mm	5/8 in. 16 mm	L10-26
HS18-211	76A9201			20 ft. - 50 ft.
HS18-261	26F2101			6 m - 15 m
HS18-311	76A9001	3/8 in. 10 mm	3/4 in. 19 mm	L10-41
HS18-410	26F2001			20 ft. - 50 ft. 6 m - 15 m
HS18-460	P-8-11322	3/8 in. 10 mm	7/8 in. 22 mm	L10-65
HS18-510	47F6001			30 ft. - 50 ft. 9 m - 15 m
HS18-650	47F6201	3/8 in. 10 mm	1-1/8 in. 29 mm	FIELD FABRICATED

Piping Connections at Indoor Coil

Piping consists of flare connections to indoor coil.

- 1 - RFC II Orifice
Install the RFC II orifice as illustrated below. Table matches the correct RFC II number to corresponding HS18 unit.
- 2 - Expansion Valve Kit
Refer to installation instructions with indoor coil and expansion valve kit.

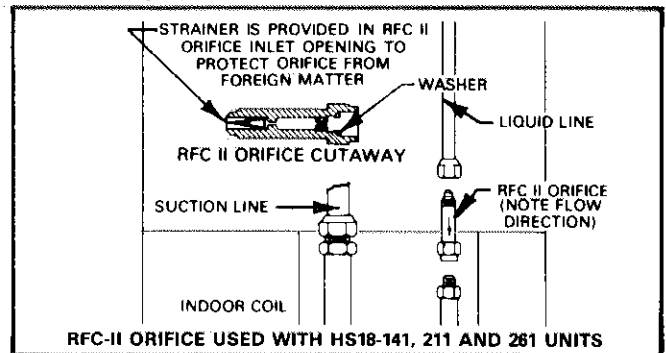

REFRIGERATION

Service Valves and Gauge Manifold Attachment

The liquid line and suction line service valves and gauge ports are accessible from outside of the unit (**the "one shot" suction line service valve cannot be closed once it has been opened**). These gauge ports are used for leak testing, evacuating, charging and checking charge

IMPORTANT - Service valves are closed to condensing unit and open to line set connections. Do not open until refrigerant lines have been leak tested and evacuated. All precautions should be exercised in keeping the system free from dirt, moisture, and air.

Leak Testing

- 1 - Attach gauge manifold and connect a drum of dry nitrogen to center port of gauge manifold.
CAUTION - When using dry nitrogen, a pressure reducing regulator must be used to prevent excessive pressure in gauge manifold, connecting hoses, and within the system. Regulator setting must not exceed 150 psig (1034 kPa).
- 2 - Open high pressure valve on gauge manifold and pressurize line set and indoor coil to 150 psig (1034 kPa).
- 3 - Check lines and connections for leaks.
NOTE - If electronic leak detector is used, add a trace of refrigerant to the nitrogen for detection by the leak detector.
- 4 - Release nitrogen pressure from the system, correct any leaks and recheck.

Evacuating and Dehydrating the System

- 1 - Attach gauge manifold and connect vacuum pump (with vacuum gauge) to center port of gauge manifold. With both

gauge manifold service valves open, start the pump and evacuate evaporator and refrigerant lines.

NOTE - A temperature vacuum gauge, mercury vacuum "U" tube or thermocouple gauge should be used. The usual Bourdon tube gauges are inaccurate in the vacuum range.

- 2 - Evacuate the system to 29 inches (737 mm) vacuum. During the initial stages of evacuation, stop the vacuum pump at least once to determine if there is a loss of vacuum. A rapid loss of vacuum indicates a leak in the system.
- 3 - After system has been evacuated to 29 inches (737 mm) close manifold valves to center port. Stop the vacuum pump and disconnect from gauge manifold. Attach a drum of dry nitrogen to center port of gauge manifold, open drum valve slightly to purge line, then break vacuum in system to 3 psig (20.7 kPa) pressure by opening manifold high pressure valve to center port.
- 4 - Close nitrogen drum valve, disconnect drum from manifold center port, and release nitrogen pressure from system.
- 5 - Reconnect vacuum pump to manifold center port hose. Evacuate system through manifold service valves until vacuum in system does not rise above 29.7 inches (754 mm) mercury (5 mm absolute pressure) within a 20 minute period after stopping vacuum pump.
- 6 - After evacuation is completed, close gauge manifold service valves. Disconnect vacuum pump from manifold center port and connect **refrigerant drum**. Pressurize system slightly with refrigerant to break vacuum.

REFRIGERATION

Start-Up

- 1 - Rotate fan to check for frozen bearings or binding.
- 2 - Inspect all factory and field installed wiring for loose connections.
- 3 - Open liquid line and suction line service valves to release refrigerant charge (contained in condensing unit) into the system. Replace stem cap on liquid line valve. Make sure caps on both valves are tight.
- 4 - To open suction valve, tighten the opening cap (longest) until a bottoming is felt (nut will be within 1/8" or less of the body). Tighten an additional 1/4 turn to make the metal to metal seal.

NOTE - When tightening, the torque will increase, then drop off as the frangible plug shears.

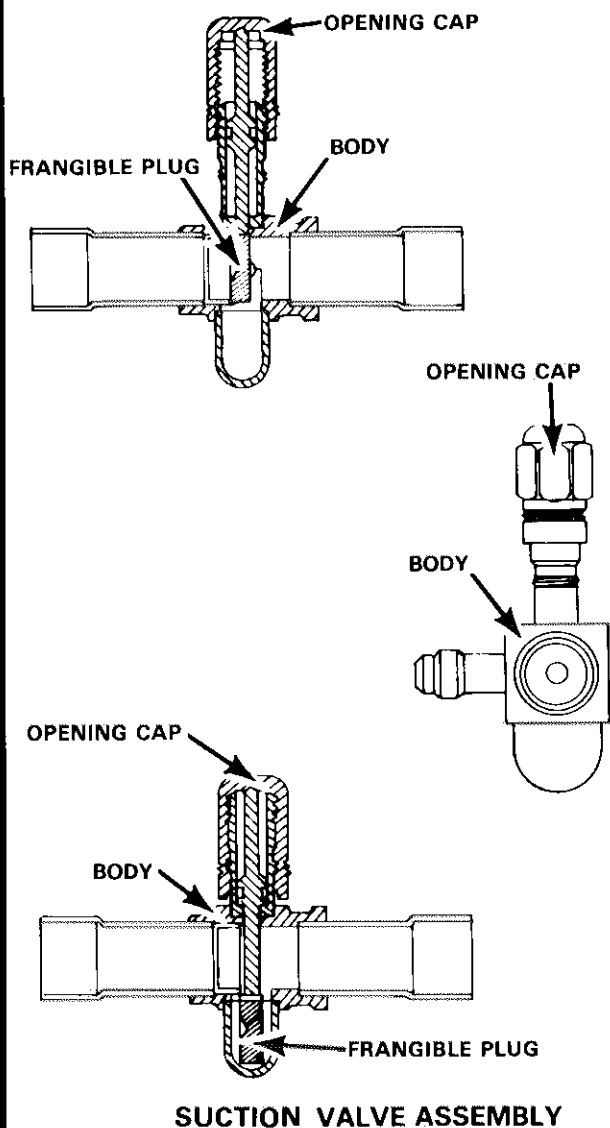

- 5 - Check voltage supply at the disconnect switch. The voltage must be within the range listed on unit nameplate. If not, do not start the equipment until the power company has been consulted and the voltage condition corrected.
- 6 - Set the thermostat for a cooling demand, turn on power to evaporator blower and close condensing unit disconnect to start unit.
- 7 - Recheck unit voltage with unit running. Power must be within range shown on unit nameplate. Check amperage draw of unit. Refer to unit nameplate for correct running amps.

Charging

The units are factory charged with the amount of R-22 refrigerant indicated on the unit rating plate. This charge is based on a matching indoor coil and outdoor coil with 20 ft. (6.10 m) line set. For varying lengths of line set, refer to table below for refrigerant charge adjustment. A blank space is provided on the unit rating plate to list actual field charge.

Line Set Diameter		Ounce per foot (ml per mm) adjust from 20 foot (6096 mm) line set*
Suction	Liquid	
5/8 in. (16 mm)	5/16 in. (8 mm)	1/2 ounce (15 ml)
5/8 in. (16 mm)	3/8 in. (10 mm)	1/2 ounce (15 ml)
3/4 in. (19 mm)	3/8 in. (10 mm)	1/2 ounce (15 ml)
7/8 in. (22 mm)	3/8 in. (10 mm)	1/2 ounce (15 ml)
1-1/8 in. (29 mm)	1/2 in. (13 mm)	1 ounce (30 ml)

*If line set is greater than 20 ft. (6.10 m), add this amount. If line set is less than 20 ft. (6.10 m), subtract this amount.

Refrigerant charge is checked by use of a "Normal Operating Pressure Curve" mounted in each unit. Three factors are needed to use the pressure curve: condenser entering air temperature, suction pressure and liquid pressure.

With gauge manifold attached and an upright R-22 drum connected to center port of manifold proceed as follows:

- 1 - Open drum valve and charge a quantity of refrigerant gas into the system through the suction port. Close refrigerant drum valve and allow unit to run for a few minutes to stabilize operating pressures.
- 2 - Using a thermometer, record the condenser entering air temperature, and record the suction and liquid operating pressures.
- 3 - From the "Normal Operating Pressure Curve", on the unit, find the suction pressure and follow across the curve to the correct entering air temperature. From this point, read down to the liquid pressure. If the liquid pressure is within 3 psig (20.7 kPa) of the reading on manifold high pressure gauge the unit is properly charged.
- 4 - Continue to charge and check until proper charge is obtained (Steps 1, 2 and 3 above).
- 5 - After charging, remove gauge manifold and replace service caps.

NOTE - For systems void of refrigerant, the recommended and most accurate method of charging is to weigh the refrigerant into the unit according to the amount shown on the unit nameplate. Refer to the Lennox Service Manual for procedure. If weighing facilities are not available or if unit is just low on charge, use the procedure as given above.

OPERATION — MAINTENANCE

SYSTEM OPERATION

Condensing unit and indoor blower cycle on demand from room thermostat. When blower switch on thermostat is switched to "ON" position, indoor blower operates continuously.

High Pressure Switch

(HS18-311, -410, -460, -510 and -650 units only)

The high pressure switch located in the control box shuts off unit operation at 410 psig (2827 kPa) and must be manually reset.

Crankcase Heater

4 and 5 ton units are equipped with internal self regulating crankcase heaters.

Compressor Start Kit

4 and 5 ton single phase units have integral start components eliminating any need for field installation of start kits.

MAINTENANCE

At the beginning of each cooling season, the system should be checked as follows:

Condensing Unit

- 1 - Clean and inspect condenser coil. (Coil may be flushed with a water hose.)
- 2 - Condenser fan motor is prelubricated and sealed for extended bearing life. No further lubrication is required.

- 3 - Visually inspect connecting lines and coils for evidence of oil leaks.
- 4 - Check all wiring for loose connections.
- 5 - Check for correct voltage at unit (unit operating).
- 6 - Check amp-draw on condenser fan motor.

Unit nameplate _____ Actual _____

NOTE - If owner complains of insufficient cooling, the unit should be gauged and refrigerant charge checked. Refer to section on refrigerant charging in this instruction.

Evaporator Coil

- 1 - Clean coil, if necessary.
- 2 - Check connecting lines and coils for evidence of oil leaks.
- 3 - Check condensate line and clean, if necessary.

Indoor Unit

- 1 - Clean or change filters.
- 2 - Adjust blower speed for cooling. The pressure drop over the coil should be measured to determine the correct blower CFM. Refer to the Cooling Service Handbook for pressure drop tables and procedure.
- 3 - *Belt Drive Blowers* - Check belt for wear and proper tension.
- 4 - Check all wiring for loose connections.
- 5 - Check for correct voltage at unit (blower operating).
- 6 - Check amp-draw on blower motor.

Motor nameplate _____ Actual _____