

LENNOX OUTDOOR INSTALLED HEATING & VENTILATING

FACTORY ASSEMBLED MODULAR EQUIPMENT GS3-400, WS3-400 HORIZONTAL AND DOWN-FLOW

GAS 250,000 and 400,000 BTU/H Heat Output
 263,75 and 422,00 MJ/H " "
 73.3 and 114 kW " "

WATER UP TO 600,000 BTU/H Heat Output
 633 MJ/H " "
 175.8 kW " "

CI/StB	(56)
Ref.	SS.11.1.33-34
Date	June 1973
Replaces	LE.SS.GW-400 dated April 1962

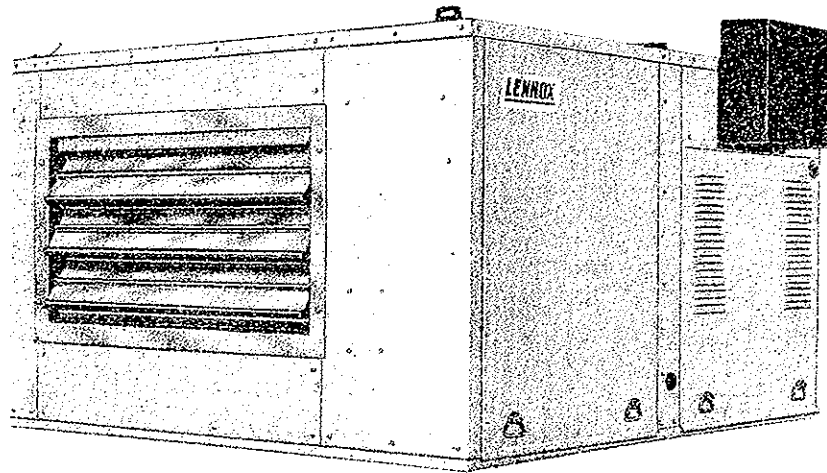

MODEL GS3-400

ROOF MOUNTING FRAME DETAIL

The frame extends around the entire perimeter of the GS3.

Duct connection and entry into the heated/ventilated area are accomplished within the confines of the weatherproof frame.

Single Package Outdoor Unit and Mounting Frame saves Installation Costs and Floor Space

Single package concept and optional roof mounting frame are LENNOX exclusive features which give Lennox advantages over competition both in appearance and installation procedures. A highly efficient tubular heat exchanger, powerful belt drive blowers, air filters and space to receive the optional Lennox Fresh Air Damper Kit are all housed in a single insulated weatherproof cabinet. The Fresh Air Damper Kit is supplied with all its internal controls wired, and can be installed to utilize 100% outside air for ventilation. The WS3-400 is fitted with a frost protection thermostat. Where quantities of both outside and recirculated air are required through the GS3-400 during winter periods the controls ensure a minimum "on exchanger" temperature of 6°C (43°F). The separate roof mounting frame mates to the unit base and when flashed into the roof, permits weatherproof duct connection and entry into the area to be heated and ventilated. No additional roof curbing or flashing is required—the RMF frame does the

entire job. Equipment is designed for rooftop installation utilising underside duct connections, slab installation, utilising end openings, or inside installation with the appropriate flue system. Three air patterns are possible with the same unit, down-flow (dual duct or combination supply/return), horizontal supply and return, bottom supply/horizontal return or horizontal supply/ bottom return.

The optional Ventilation equipment and controls provide natural cooling at low operating costs and, in connection with the powerful blowers, can provide fresh air to suit almost any requirements.

An externally mounted minimum fresh air damper is also available. A de-luxe wall mounted two stage heating thermostat is supplied as standard.

NOTE: Specifications, ratings and dimensions subject to change without notice.

FEATURES

GS3-400 & WS3-400

The New LENNOX Duratube Heat Exchanger

—All surfaces of this remarkable new heat exchanger are essentially at the same temperature when the unit is fired. This even heat, with no cool spots, assures virtual elimination of any condensation the enemy of any heat exchanger. The cylindrical drum and tube construction not only make even temperatures possible, but allows the heat exchanger to contract and expand without undue metal fatigue.

These same round surfaces create practically no resistance to air movement around the heat exchanger. Air wipes all surfaces uniformly for efficient transfer of heat quietly, effortlessly. Heating surfaces are of aluminised steel for long life.

Forced combustion air also permits flue terminal to be almost flush with cabinet.

GS3 unit has a stainless steel burner. First stage and second stage firing are controlled by a motorized valve feeding the gas supply to the single combustion head. Two stage operation is available for both natural and town gases. The stages are controlled by the two stage heating thermostat. Pilot flame is lit by an intermittent spark. Electronic flame sensing controls are standard.

Two Stage Heating is achieved in the GS3 through a De-Luxe wall mounted two stage heat thermostat. When room temperature drops $1\frac{1}{2}^{\circ}\text{F}$ below thermostat setting the first stage mercury bulb energises sequencer which, after lighting the pilot and proving the pilot flame, opens the hydromotor valve on low fire. If the room temperature drops another $1\frac{1}{2}^{\circ}\text{F}$, the second stage mercury bulb operates and fully opens the hydromotor valve to give high fire operation.

The **WS3** is fitted with a specially designed and manufactured hot water coil. Made of the finest 0.020 inch thick copper tube with 0.0095 inch aluminium fins to obtain maximum heat transfer. A two-row, ten circuit coil coupled with a range of water temperatures, flow rates and air volumes make this unit extremely versatile. (See performance charts).

Optional Secondary Circulating Systems—A secondary circulating kit SCK-400 provides a simple and practical method of zone control. Factory or site fitted the kit comprises all necessary fittings, circulating pump, three way modulating valves and thermostats. The SCK-400 should not be confused with primary hot water circuit pump supplied by the contractor.

Optional Ventilation—Fresh Air Damper Kit—

The FAD-400 is a kit mounted internally with the purpose of providing natural cooling by the introduction of fresh outside air. To handle the operation, this ventilating system consists of mechanically linked outdoor air and recirculated air dampers.

On the GS3-400 remote modulating control of these dampers operates a motor and linkage system giving infinitely variable mixtures of fresh and recirculated air, and ensures a minimum "air on" temperature at the heat exchanger of 43°F . The two damper sections simply fit into cavities provided in the heater cabinet. The fresh air intake section is furnished with a hood. When ordering use suffix G for GS3 and W for WS3.

FAD-400 is suitable for applications where return air enters the base of the unit. For other applications see your Lennox Area Manager.

Control of Heating and Ventilating—Automatic Control of the heating system is by a wall mounted two stage heat thermostat, supplied as standard.

Control of the optional FAD-400 Fresh Air Damper Kit is by a remote variable rheostatic control.

Optional Minimum Fresh Air Damper—

When the simultaneous control of both fresh air and return air intakes to the unit, using the optional FAD-400, is not required an externally mounted minimum fresh air damper section OAD3-135 is available. It can be either manually adjusted to give a selected volume of fresh outside air or motor operated with remote control.

Order automatic Kit for OAD3 Damper, Part BM-3740.

Complete Service Access—Large removable panels give complete service access to interior. Complete access to heating element is through the removable rear breeching. Remove vent cap for access to flue breeching. Burner assembly is easily removed for servicing.

A viewing port is fitted in the unit to permit observation of the flame at all times.

Thick Interior Insulation—All of the interior is lined with 1" thick glass fibre insulation. This results in quiet and efficient operation due to the excellent accoustical and insulating qualities of glass fibre.

Standard Controls—Limit Controls and electronic flame proving controls protect heating system from abnormal operating conditions. Low voltage room thermostat has accurate temperature sensing section linked to two mercury switches for two stage heat control. Blower motor is protected with overloads.

Optional Controls—Special controls to suit particular environmental requirements can be supplied, including time switches and night set-back controls. Ask your Lennox Area Manager for details.

Powerful Blowers—Two statically and dynamically balanced blowers operate on a single shaft with double belt drive. All moving parts of blower assembly float on high tensile steel coil springs, only the blower scroll is stationary. Rugged blower motor support allows quick belt adjustment and motor changeover. Large air volume range make these units suitable for all applications. See blower capacity table for drive selection.

Cleanable Air Filter—Washable or vacuum cleanable polyurethane filter media is supplied as standard. One inch thick media is standard, however filter rack will receive media up to 2" thick.

The filter allows for five supply air patterns without re-arrangement. No extra filter racks need be specified when fresh air ventilating is to be used. Filters are easily accessible for cleaning or replacement. The total filter area is more than three times the area of the air inlet to the unit for increased efficiency.

Rugged Cabinet—Built for extreme durability under all weather conditions with attractive stone coloured finish of PVC on electro-zinc coated heavy guage steel-chromate washed on the inside. All exterior bolts are chromium plated for extra weather protection. Standing seam construction of cabinet developed by Lennox over years gives rigidity and complete moisture protection.

Assembled Unit —GS3 / WS3 Series are approved as Factory Assembled Modular Equipment (FAME). Equipment is shipped completely assembled, wired and piped ready to install. Installer has only to set unit, connect ductwork, gas, oil or water supply, power supply and thermostat wire.

Optional Roof Mounting Frame—Lennox have developed a roof mounting frame, factory made to exact dimensions to suit these Modular units. A single hole in the roof structure is required and the Lennox RMF-400A (13" high) is built into the roof structure at an early stage in roof construction to be flashed and counter-flashed making it integral with the roof before the unit is in place.

Supply and return air ducts are contained within the confines of the roof mounting frame and, once the Lennox rooftop unit is in position a weathertight seal is formed, protecting the ducts and maintaining the integrity of the roof. See accessories table for ordering data.

Optional Combination Ceiling Supply and Return Air—A special version of the roof mounting frame is required for this arrangement. Order the special roof mounting frame RMF-400B. The frame is an insulated, air tight and waterproof plenum which sits on the roof support members and is built into the roof structure to match the base of the heater. Simply order the combination supply and return air duct CD3-400 to complete connection with the ceiling combination supply and return diffuser. See accessories table for ordering data.

Optional Combination Supply and Return Ceiling Diffusers—Lennox offers two different styles of air diffusers. The RTD stepdown model, extends below ceiling level when installed. The FD model is almost flush with the ceiling when installed. Supply air is discharged through the outside grilles and return air enters through the centre grille on both models. Adjustable vanes are available on both models for air distribution. The RTD stepdown model may be preferred when greater horizontal distribution is desired. See accessories table for ordering data.

Optional AF4 Adaptor Frame—Required for down-flow applications where supply duct enters through combustible roof construction. See accessories table for ordering data.

Thoroughly Tested and Approved—Certified for outdoor application, on natural and town gas, "Duratube" heat exchanger design has been laboratory life—cycle tested to prove long life of heating element. In addition, each unit is test operated at the factory.

ACCESSORIES

Accessory Description	Order Number	Weight
Modulating Fresh Air and Return Air Damper Kit	FAD-400	80 lb./36 Kg.
Minimum Fresh Air Damper	OAD3-135	60 lb./27 Kg.
Automatic Kit for OAD3 Damper	BM-3740	9 lb./ 4 Kg.
Roof Mounting Frame	RMF-400A	115 lb./52 Kg.
Roof Mounting Frame for Combination Ceiling Supply and return	RMF-400B	140 lb./61 Kg.
Combustible Adaptor	AF4-400	14 lb./ 6 Kg.
Combination Ceiling Supply and Return Duct (3 feet high)	CD3-400	25 lb./11 Kg.
Combination Ceiling Supply and Return Step Down Diffuser	RTD-185/275	131 lb./59 Kg.
Combination Ceiling S/R Flush Diffuser	FD-275	105 lb./48 Kg.
Secondary Circulating kit	SCK-400	70 lb. 31.75Kg.

SPECIFICATIONS

Description	GS3-400	WS3-400
Heating Capacity Input	1st Stage	312,500 Btu/h
	" "	Mj/h
	" "	kW/h
	2nd Stage	500,000 Btu/h
	" "	Mj/h
Output	1st Stage	250,000 Btu/h
	" "	263.75 Mj/h
	" "	73.3 kW/h
	2nd Stage	400,000 Btu/h
	" "	422.00 Mj/h
Blower Wheels (No.) Dia. x Width	(2) 15" x 11" [(2) 381 mm x 279 mm]	
	Minimum 1½ hp (1.119 kW) Maximum 3 hp (2.238 kW)	
Blower Motor (see drive selection table)		
Filters (No.) size	(6) 22" x 22" [(6) 559 mm x 559 mm]	
Entering pressures	Nat. 5" p.s.i.g. Town 3" p.s.i.g. Nat. 12.5 mbar Town 7.5 mbar	L.P.H.W.
Fuel supply connection	Nat. 1½" BSP Town 1½" BSP	Water Connection 1½" BSP
Net weight of Basic Unit	1000 lb. 450 kg.	918 lb. 420 kg.

ELECTRICAL DATA

Line Voltage (50 Cycle)		380/415 (3 ph)	400/440 (3 ph)	220/240 (1 ph)
Max. Current Drawn (Amps)				
Motor H.P.	1	2.0	1.7	6.2
	1½	2.8	2.5	8.7
	2	3.5	3.2	11.8
	3	5.0	4.5	17.5
	5.5	8.8	7.2	-

NOTE: All fuses, main switch and wiring must conform to I.E.E. and British Standards.

BLOWER DATA

GS3-400, WS3-400 PERFORMANCE CHART

STATIC PRESSURE EXTERNAL TO UNIT — Inches Water Gauge														
Air Volume (cfm)	0.1		0.2		0.3		0.4		0.5		0.6		0.7	
	RPM	BHP	RPM	BHP	RPM	BHP	RPM	BHP	RPM	BHP	RPM	BHP	RPM	BHP
4000	--	--	385	.5	425	.58	470	.68	520	.78	565	.9	600	.98
4500	--	--	400	.6	440	.68	485	.78	535	.92	575	1.04	610	1.14
5000	390	.66	430	.76	475	.86	515	.96	550	1.08	585	1.20	620	1.32
5500	415	.82	460	.92	500	1.02	530	1.14	570	1.28	605	1.40	645	1.56
6000	450	1.00	485	1.10	520	1.24	555	1.36	590	1.36	620	1.60	660	1.80
6500	480	1.22	510	1.30	550	1.47	580	1.60	610	1.72	645	1.90	675	2.02
7000	510	1.42	545	1.60	580	1.74	610	1.88	635	2.02	665	2.14	700	2.34
7500	545	1.76	570	1.88	605	2.04	630	2.18	660	2.30	685	2.42	720	2.68
8000	575	2.06	610	2.24	635	2.38	655	2.48	690	2.70	715	2.86	745	2.84
8500	600	2.68	630	2.56	660	2.74	695	2.94	720	3.12	740	3.28	--	--
9000	620	2.72	640	2.84	690	3.20	--	--	--	--	--	--	--	--

STATIC PRESSURE EXTERNAL TO UNIT — Inches Water Gauge												
Air Volume (cfm)	0.8		0.9		1.0		1.1		1.2		1.3	
	RPM	BHP	RPM	BHP	RPM	BHP	RPM	BHP	RPM	BHP	RPM	BHP
4000	635	1.12	--	--	--	--	--	--	--	--	--	--
4500	645	1.30	670	1.40	715	1.58	--	--	--	--	--	--
5000	660	1.50	690	1.62	725	1.80	755	1.92	785	2.06	--	--
5500	670	1.70	705	1.84	735	2.00	765	2.16	795	2.34	--	--
6000	690	1.94	720	2.10	745	2.26	775	2.42	810	2.62	--	--
6500	710	2.20	740	2.42	765	2.54	790	2.76	820	2.90	--	--
7000	725	2.66	755	2.70	780	2.86	810	3.06	--	--	--	--
7500	745	2.86	770	3.20	800	3.26	--	--	--	--	--	--
8000	765	3.30	--	--	--	--	--	--	--	--	--	--
8500	--	--	--	--	--	--	--	--	--	--	--	--
9000	--	--	--	--	--	--	--	--	--	--	--	--

NOTE: All cfm data is measured external to the unit using standard return air opening and with filters in place. Heating systems should be designed to obtain a minimum

" air on heat exchanger " of 43°F and a maximum temperature rise through the unit of 75°F.

DRIVE SELECTION

Model No.	Nominal Motor H.P.	RPM Range of available Drive Setups
GS3-400	1	370 - 700
	1½	490 - 700
WS3-400	2	560 - 775
	3	660 - 870
	5	815 - 970

NOTE: Specify exact BHP and RPM when ordering unit.

L.P.H.W. COIL PERFORMANCE CHART WS3-400

Nominal capacities for Coil Model SY $\frac{5}{8}$ -20-2- $\frac{1}{2}$ -43 $\frac{1}{2}$ (10)

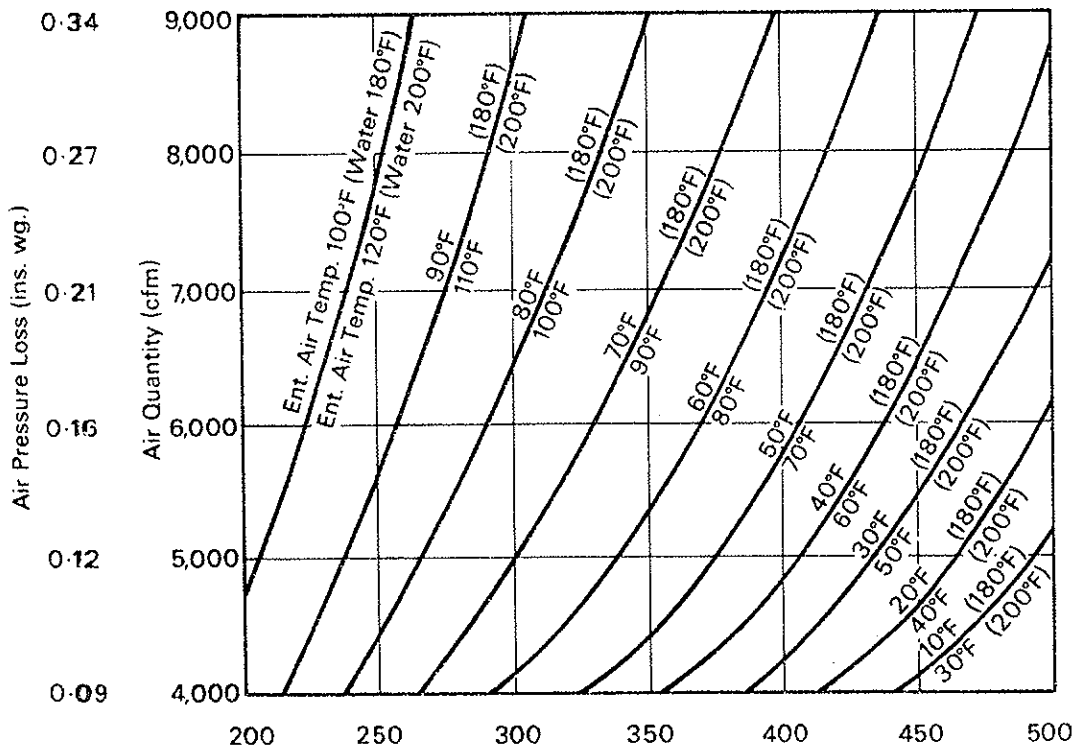
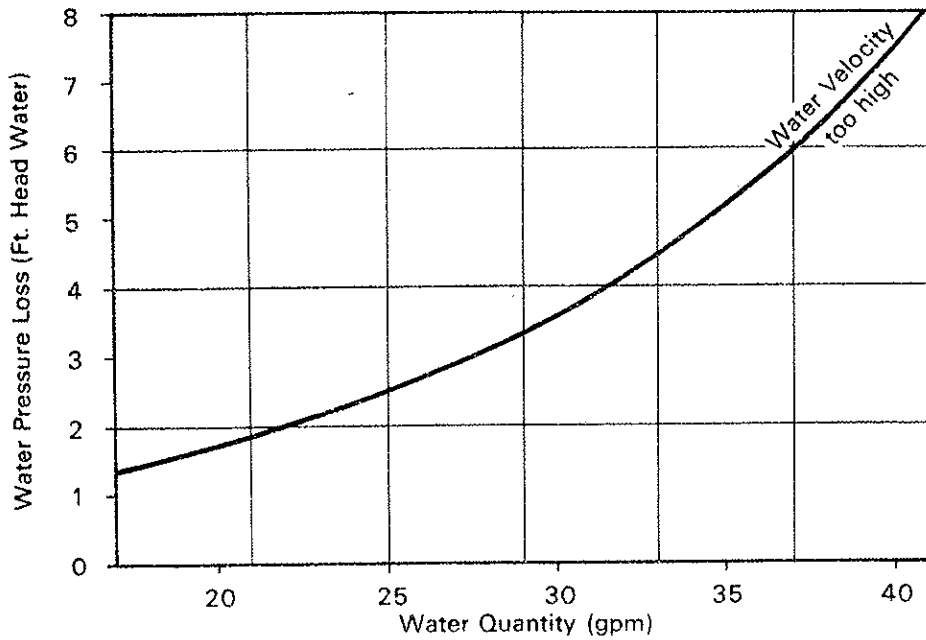

Approximate Total Heating Capacity (Btu./hr. X 1,000).
Heating medium LPHW 180°F and 200°F flow temperatures.
20°F water temperature drop.

EXAMPLE 1

6,000 CFM. with EAT. of 60°F and water temperature of 180°F provides 367,000 Btuh.
Water flow rate = 30.5 galls. / min.
Water pressure loss = 3.7 feet head
Air pressure drop = 0.16 ins. wg.

EXAMPLE 2

6,000 CFM. with EAT. of 60°F and water temperature of 200°F provides 435,000 Btuh.
Water flow rate = 35.8 galls. / min.
Water pressure loss through coil = 5.5 feet head.
Air pressure drop over coil = 0.16 ins. wg.

DIMENSIONS in. (mm)

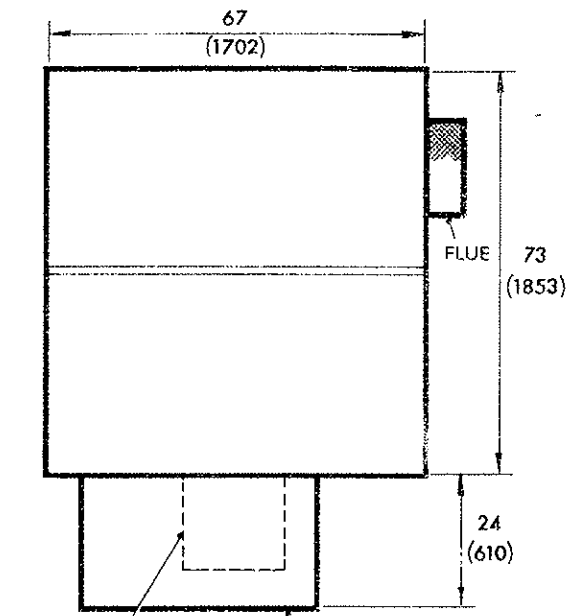

OAD3-135 Minimum Ventilation Package
Fresh Air Damper FAD-400

TOP VIEW

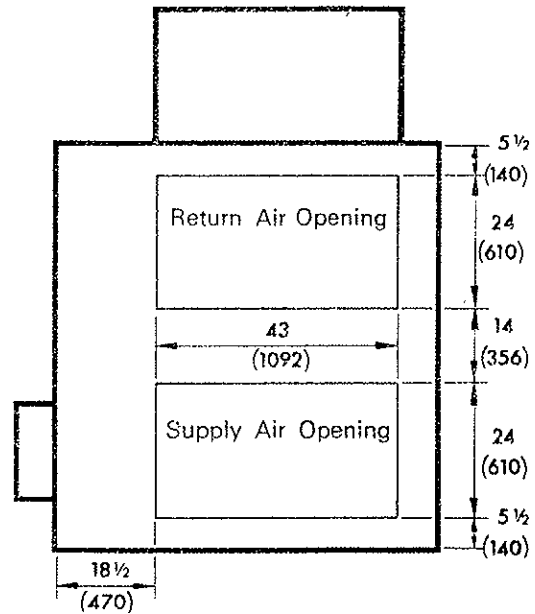

The two panels furnished fit either end or bottom openings to give choice of end or bottom air handling

BOTTOM VIEW

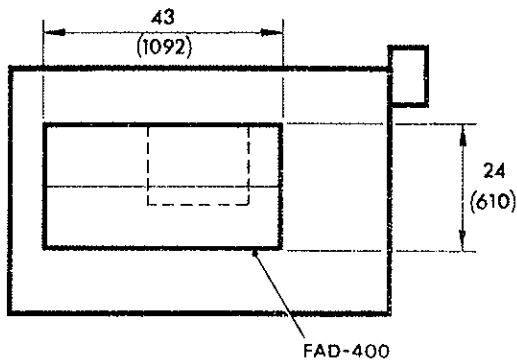

SIDE VIEW (L.H.)

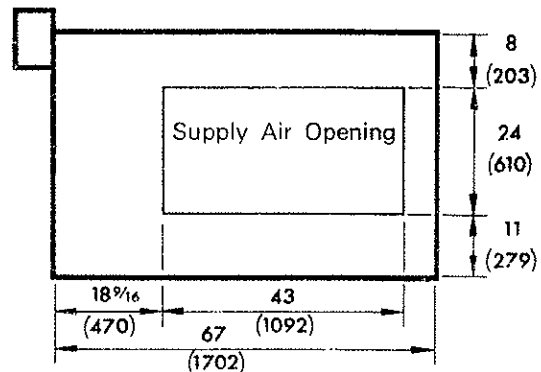

SIDE VIEW (R.H.)

Schedule of Openings

- A. 1 1/2" BSP Gas Connection
GS3 units only.
- B. 3/8" dia. for thermostat wire.
GS3 and WS3 units only.
- C. 1" dia. for Mains Power
inlet GS3 and WS3 units
only.

NOTE: Openings for the 1 1/2" BSP hot water pipes (WS3-400) can be made with a tank cutter in either the centre or corner pillar or for internal connection through the floor of the coil vestibule.

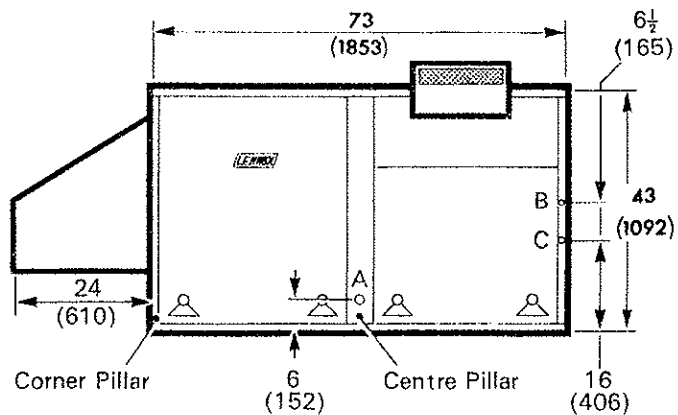

FRONT VIEW

ROOF MOUNTING FRAMES—GS3

RMF - 400A Mounting Frame with Double Duct Openings

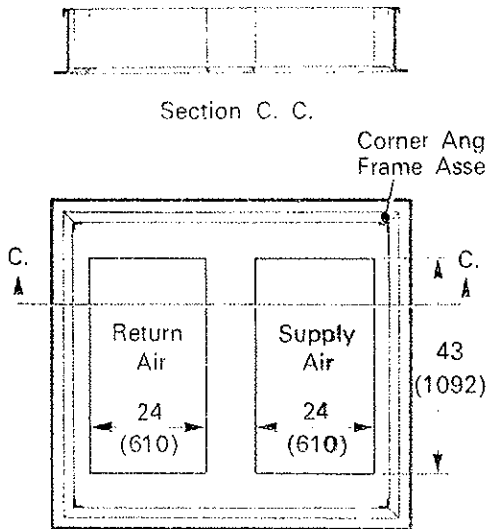

NOTE: Roof Mounting Frame for Double Duct is assembled on site

RMF - 400B Mounting Frame with Combination Ceiling and Return Opening

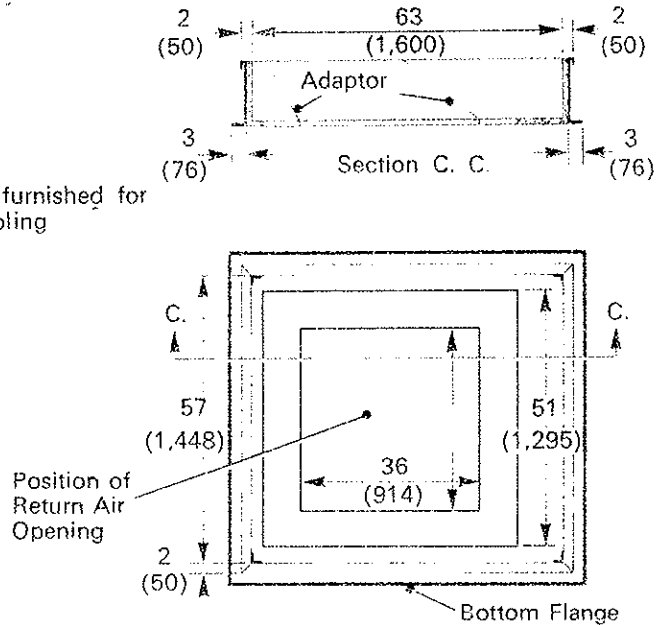

NOTE: Combination Ceiling S / R Roof Mounting Frame is assembled on Site

NOTE: Roof Deck may be omitted within confines of Frame

BLOWER DATA (contd.)

Accessory Pressure Drop

Air Volume (cfm)	Fresh Air Damper	Total Pressure Drop (in. Water Gauge)			
		RTD Combination Ceiling Supply and Return			FD Ceiling Supply and Return
		2 sides open	3 sides open	4 sides open	
4000	0.08	0.34	0.27	0.26	0.09
4500	0.10	0.35	0.28	0.27	0.10
5000	0.13	0.36	0.29	0.28	0.12
5500	0.16	0.38	0.32	0.30	0.13
6000	0.20	0.40	0.35	0.32	0.15
6500	0.23	0.45	0.39	0.35	0.17
7000	0.27	0.53	0.44	0.39	0.20
7500	0.31	0.64	0.50	0.44	0.24
8000	0.35	0.79	0.58	0.51	0.29
8500	0.40		0.69	0.60	0.34

NOTE: Pressure Drop includes Grille and 3' of Ductwork.

Ceiling Supply Air Throw Data

Air Volume (cfm)	Radius of Diffusion (Feet)	
	* RTD Step Down	* Flush
4000	32	20
4500	34	23
5000	36	26
5500	38	29
6000	40	32
6500	42	36
7000	44	39
7500	46	42
8000	48	45
8500	50	48

* Four Sides Open.

ROOF MOUNTING FRAMES (contd.)

OAD3 135 Damper Assembly
(Optional) Dimensions ins. (mm)

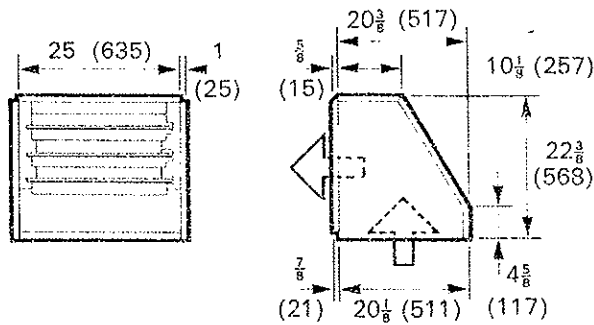

Recommended Flashing for
RMF3 Roof Mounting Frame
ins (mm)

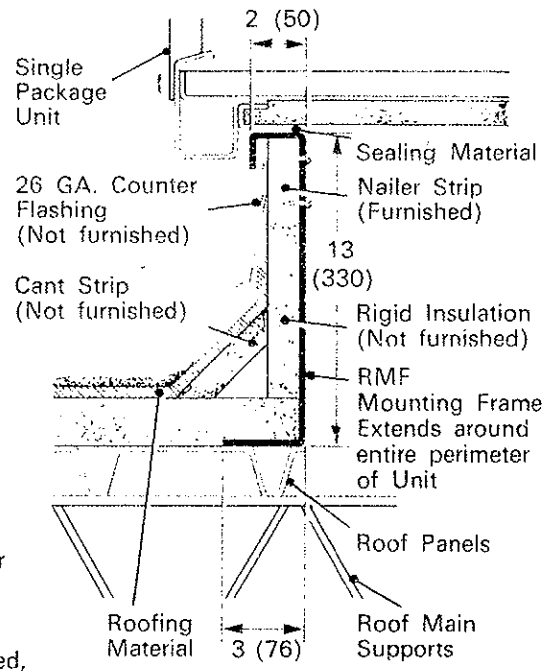

Ceiling Diffusers Flush

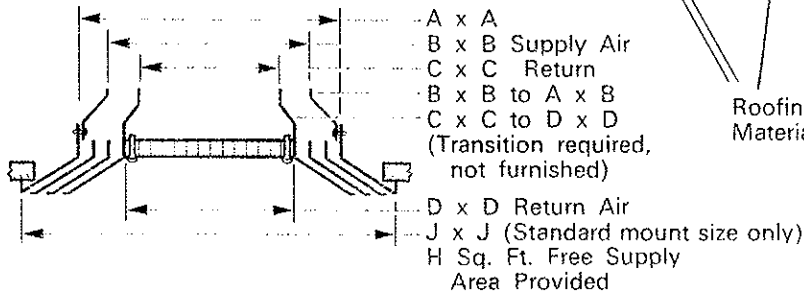

NOTE: Also available with Blade Adjustment and Hinged Core same Dimensions as above

RTD Step Down

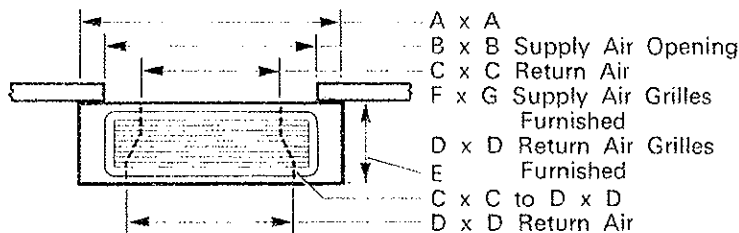

Unit Model No.	Supply and Return Air Grille Model No.		A	B	C	D	E	F	G	H	J	
GS3 - 400	RTD - 185 / 275 Step Down *	ins.	60	51	36	42	15	48	12			
		mm	1,524	1,295	914	1,067	381	1,219	305			
	FD - 275 Flush (Removable Core) FD - 275 - D Flush (Hinged Core)	ins.	63	51	36	45					9.06	56 1/2
		mm	1,600	1,295	914	1,143					sq. ft.	1,702

* These dimensions apply to flush fitted step down models. When step down diffusers are suspended below ceiling level filler plates are required between the supply duct and diffuser opening.

SUPPLY AND RETURN AIR PATTERNS

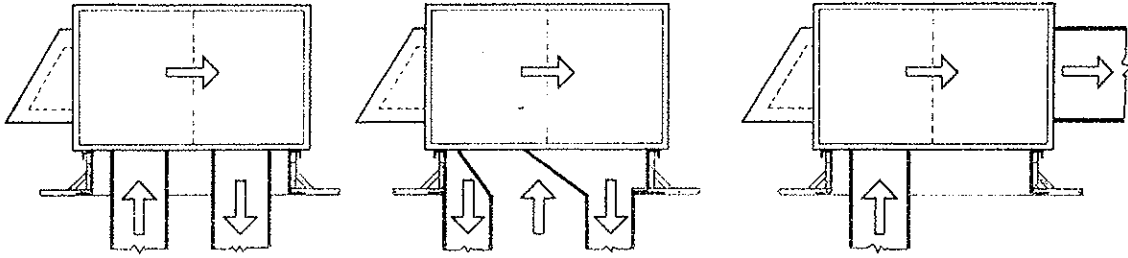

Bottom supply and return

Down-flow combination supply/return (order separate combination supply/return duct)

Horizontal Supply Bottom Return

COMBINATION CEILING SUPPLY AND RETURN—GS3 WS3

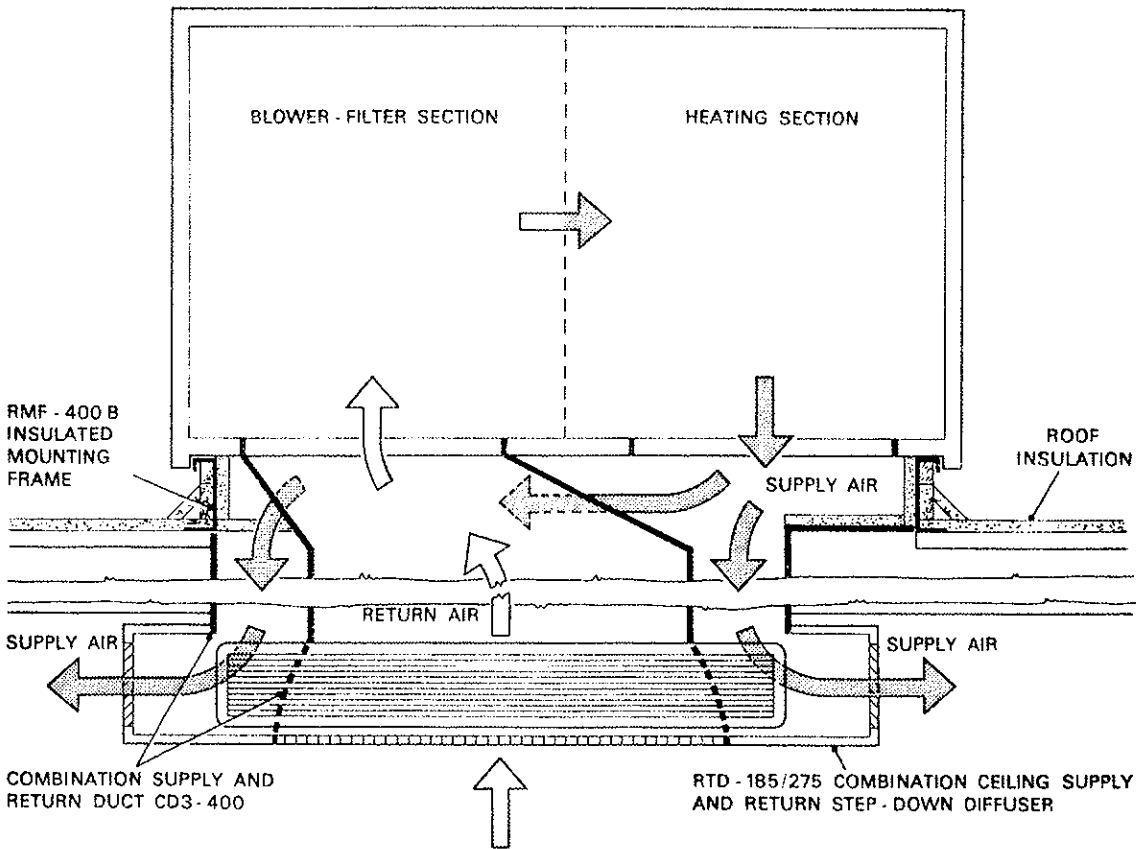

GUIDE SPECIFICATIONS

General—Supply and install an outdoor gas fired, packaged heating ventilating system, complete with automatic controls.

The installed weight shall not be more than lb. The equipment shall be shipped completely assembled, piped and wired internally ready for field connections. In addition, manufacturer shall test operate system at the factory before shipment.

Roof Mounting Frame—Supply and install a steel roof mounting frame. It shall mate to the bottom perimeter of the equipment. When flashed into the roof it shall make a unit mounting curb and provide weatherproof duct connections and entry into the conditioned area.

Air Distribution—Equipment shall be capable of (end or bottom) handling of treated air.

Furnish and install a (flush or stepdown) combination ceiling supply and return grille. It shall be capable of not less than ft. radius of effective throw.

Modulating Fresh Air and Return Air Damper Kit—Supply and install complete with all controls an air mixing damper assembly including fresh air and recirculated air dampers. The assembly shall mate with the GS3 or WS3 casing.

Heating System GS3-400—The heating capacity output shall be Btuh. Automatic controls furnished shall give 50/50 two stage operation.

Cylindrical tube and drum heat exchanger shall be constructed of aluminized steel. Stainless steel power burner shall use 100% secondary air and have intermittent spark ignition and 100% safety shutoff electronic flame sensing controls. All controls shall be listed for operation at low outdoor air temperatures. Visual inspection of burner flame shall be possible without removing casing panels.

Air Movers—Twin centrifugal treated air blowers shall have permanently lubricated ball bearings, adjustable belt drives and be capable of delivering cfm at an external static pressure of inches water gauge requiring not more than bhp and rpm. All motors shall have inherent protection devices.

Frame and Casing—The frame shall be of welded construction. The casing shall be of galvanized panels with a baked on outdoor acrylic finish. Cabinet panels shall be insulated with not less than 1" thick glass fibre.

Air Filters—Cleanable filters furnished shall have not less than sq. ft. of free area.

Service Access—All components, wiring and inspection area shall be completely accessible through removable panels which have locking door handles.

LENNOX Industries Ltd.,

P.O. Box 43
Lister Road,
Basingstoke, Hampshire.
RG22 4AR
Tel: (0256) 61261 Telex: 858675