

LENNOX®**INSTALLATION INSTRUCTIONS**©1998 Lennox Industries Inc.
Dallas, Texas**KITS COMMON TO HEATING
AND COOLING EQUIPMENT**Technical
Literature
Litho U.S.A.502,818M
11/98
Supersedes 3/96**LOW AMBIENT CONTROL KIT****INSTALLATION INSTRUCTIONS FOR LOW AMBIENT CONTROL KIT LB-57113BM (27J00)
USED WITH SINGLE-COMPRESSOR HEAT PUMP UNITS****SHIPPING AND PACKING LIST****Package 1 of 1 contains:**

- 1- Low ambient pressure switch assembly (S11)
- 1- 36" (914 mm) length of 1/4" (6.35 mm) copper tube with flare nuts
- 1- Relay
- 1- 20-Foot length of wire
- 4- 20" Lengths of wire
- 1- Bag assembly each containing:
 - 8-Wire nuts
 - 2-Saddle valves
 - 4-#10-16 X 5/8" S.D.S.T. screws
 - 1-Schrader depressor tee with seal cap

APPLICATION

The low ambient pressure switch (S11) cycles the outdoor fan while allowing compressor operation in the cooling cycle. This intermittent fan operation results in a high evaporating temperature which allows the system to operate without icing the evaporator coil and losing capacity. This kit is designed for use in ambient temperatures no lower than 30°F.

Lennox recommends a belly-band style crankcase heater (P-8-8852, 240v, 45w) be added to compressors which do not have one. A freezestat (LB-62858CA) should also be added to any system using a low ambient kit.

NOTE - Do not use this low ambient kit on units with capillary tube metering devices. Install an expansion valve metering device if using this kit.

INSTALLATION**A-Pressure Switch Assembly**

- 1- Disconnect power to unit.
- 2- Remove compressor compartment access panel.
- 3- Install valve depressor tee discharge line gauge port.
- 4- Install pressure switch in compressor compartment with screws provided. Switch should be installed in a vertical position higher than mid-point of compressor. See figure 1.

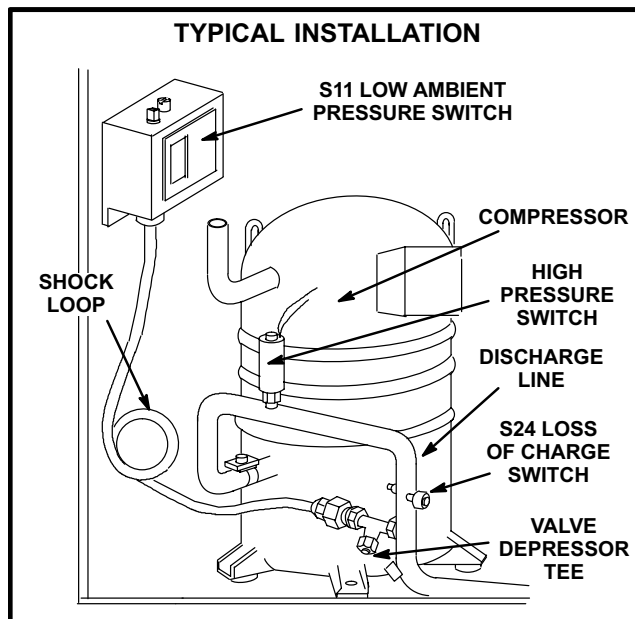
**FIGURE 1**

- 5- Connect copper line to low ambient pressure switch and open side of depressor tee (provided). Provide a shock loop in copper tubing to prevent breakage from vibration. Tighten connections. Depressor tee port with valve core is used as service port. If necessary, valve core can be moved to other leg of tee.

B-Low Ambient Pressure Switch Setting (S11)

One of two types of pressure switches are provided. The Ranco switch has one square and one round adjustment knob and the Alco switch has two square adjustment knobs.

Ranco Model

The low ambient pressure switch provided in the kit is factory set for 285 psig (1965 kPa) cut-in and 140 psig (965 kPa) cut-out.

If necessary, adjust low ambient pressure switch as follows:

- 1-Rotate round knob to set cut-in pressure. Refer to right set of indicating numbers on face of control. See figure 3.
- 2- Rotate square knob to set differential indicator to 145 psig (999 kPa). Refer to left set of indicating numbers.

Alco Model

If necessary, adjust low ambient pressure switch as follows:

- 1-Rotate the square knob located on the left to set cut-in pressure. Refer to left set of indicating numbers on face of control. See figure 2.
- 2- Rotate the square knob located on the right to set differential indicator to 145 psig (999 kPa). Refer to right set of indicating numbers.
- 3- Use only terminals 1 and 4 when connecting wiring.

NOTE - Disregard "Cut out minus Diff. is Cut In" statement on face of control. This does not apply in this application.

C-Low Ambient Relay (K58)

- 1- Install low ambient relay in control box.

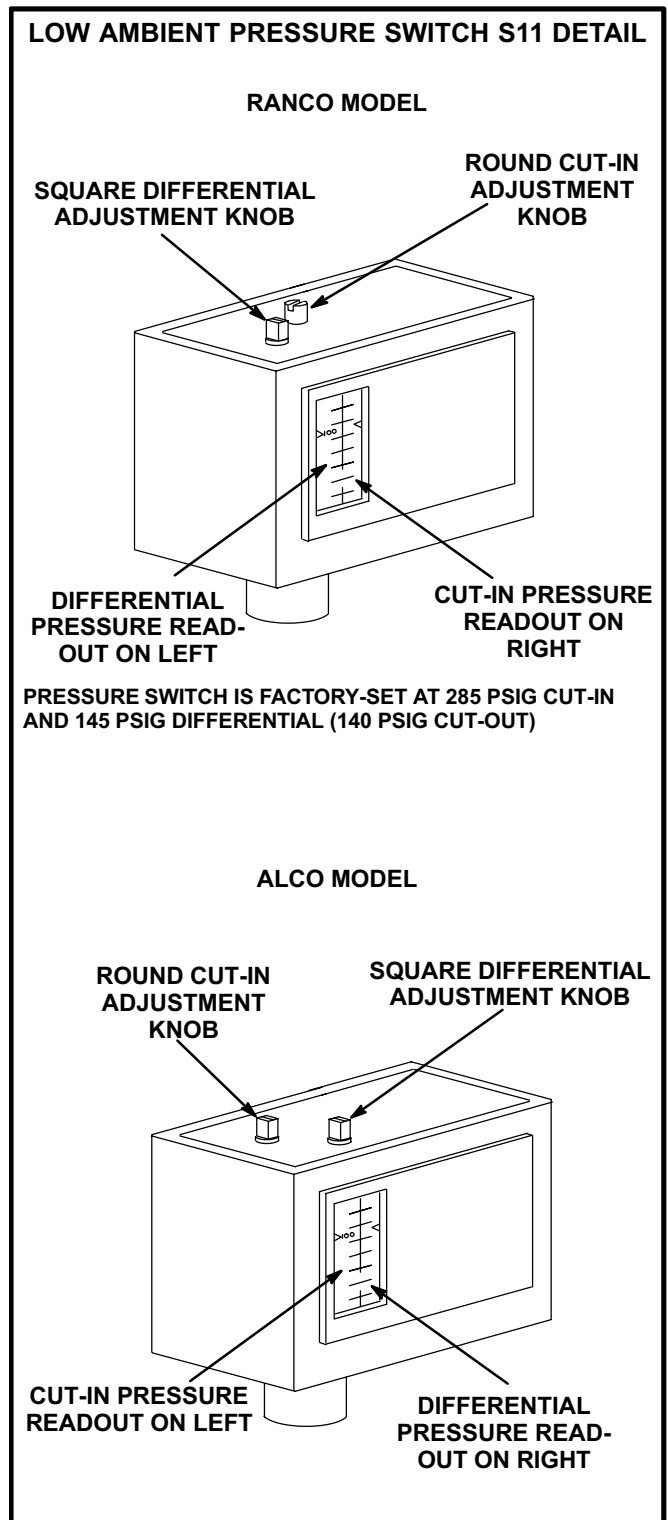

FIGURE 2

WIRING

Low ambient pressure switch S11 is wired in series with outdoor fan relay or compressor contactor (single-stage or speed units).

Low ambient kits are shown with optional arrows on unit wiring diagrams. If unit wiring diagram is not available or does not show the low ambient kit, refer to appropriate wiring diagram in figures 3 through 13 for wiring connections.

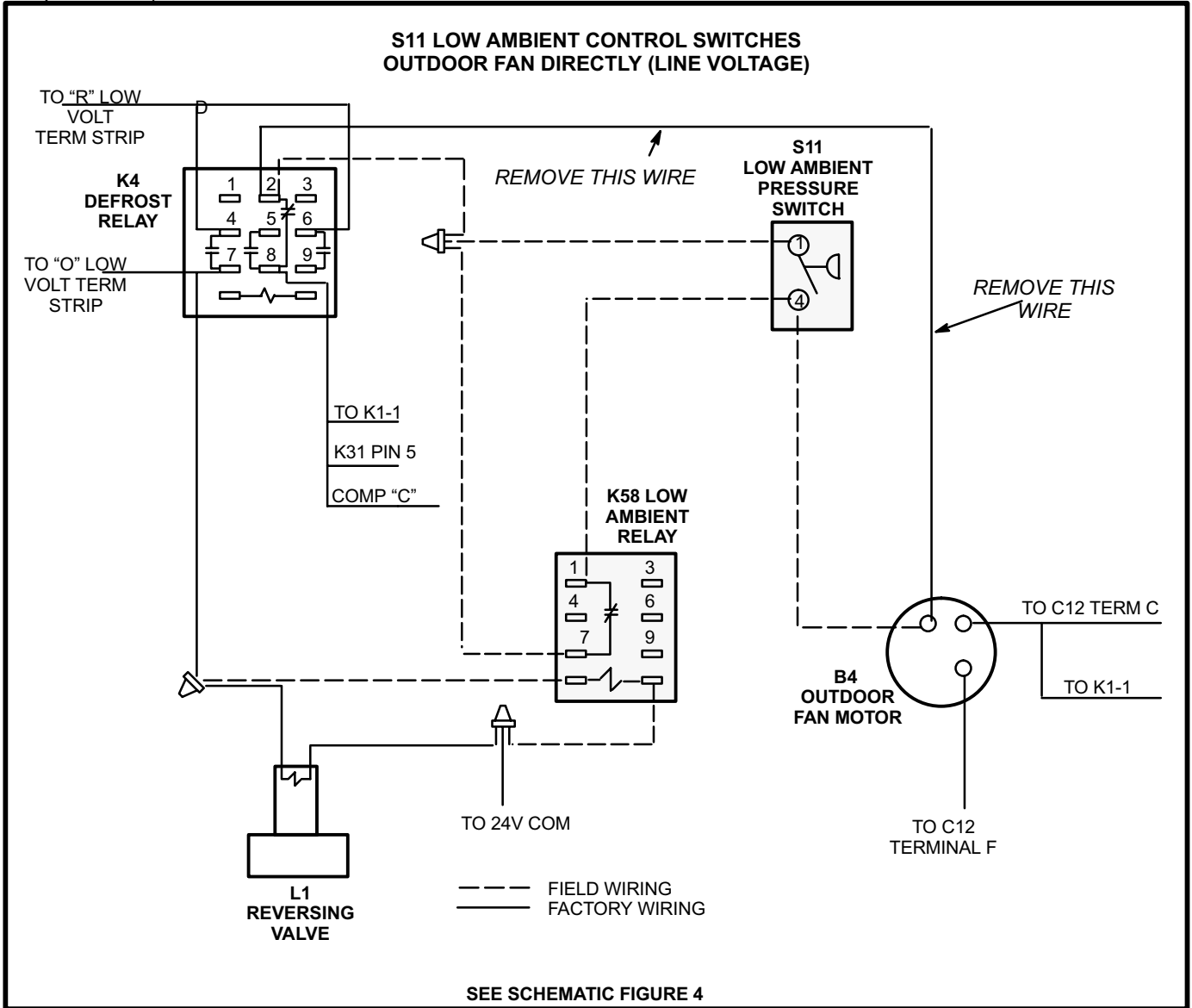
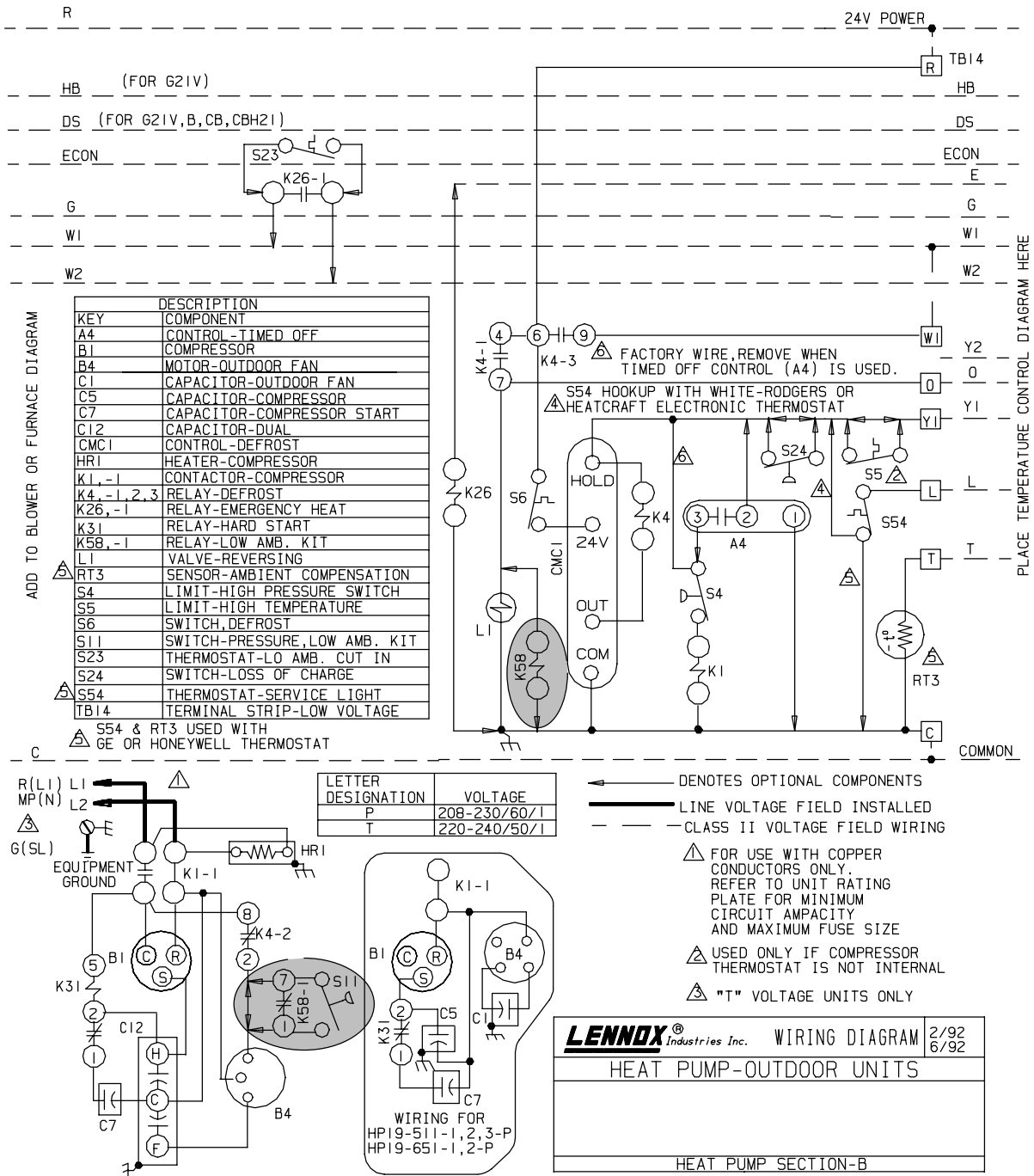

FIGURE 3

TYPICAL SINGLE-COMPRESSOR HEAT PUMP UNIT WIRING DIAGRAM (S11 LOW AMBIENT CONTROL SWITCHES OUTDOOR FAN DIRECTLY)



SEE PICTORIAL FIGURE 3

FIGURE 4

TYPICAL SINGLE-COMPRESSOR HEAT PUMP UNIT WIRING DIAGRAM

(S11 LOW AMBIENT CONTROL SWITCHES OUTDOOR FAN THROUGH A RELAY OR CONTACTOR (PILOT CIRCUIT))

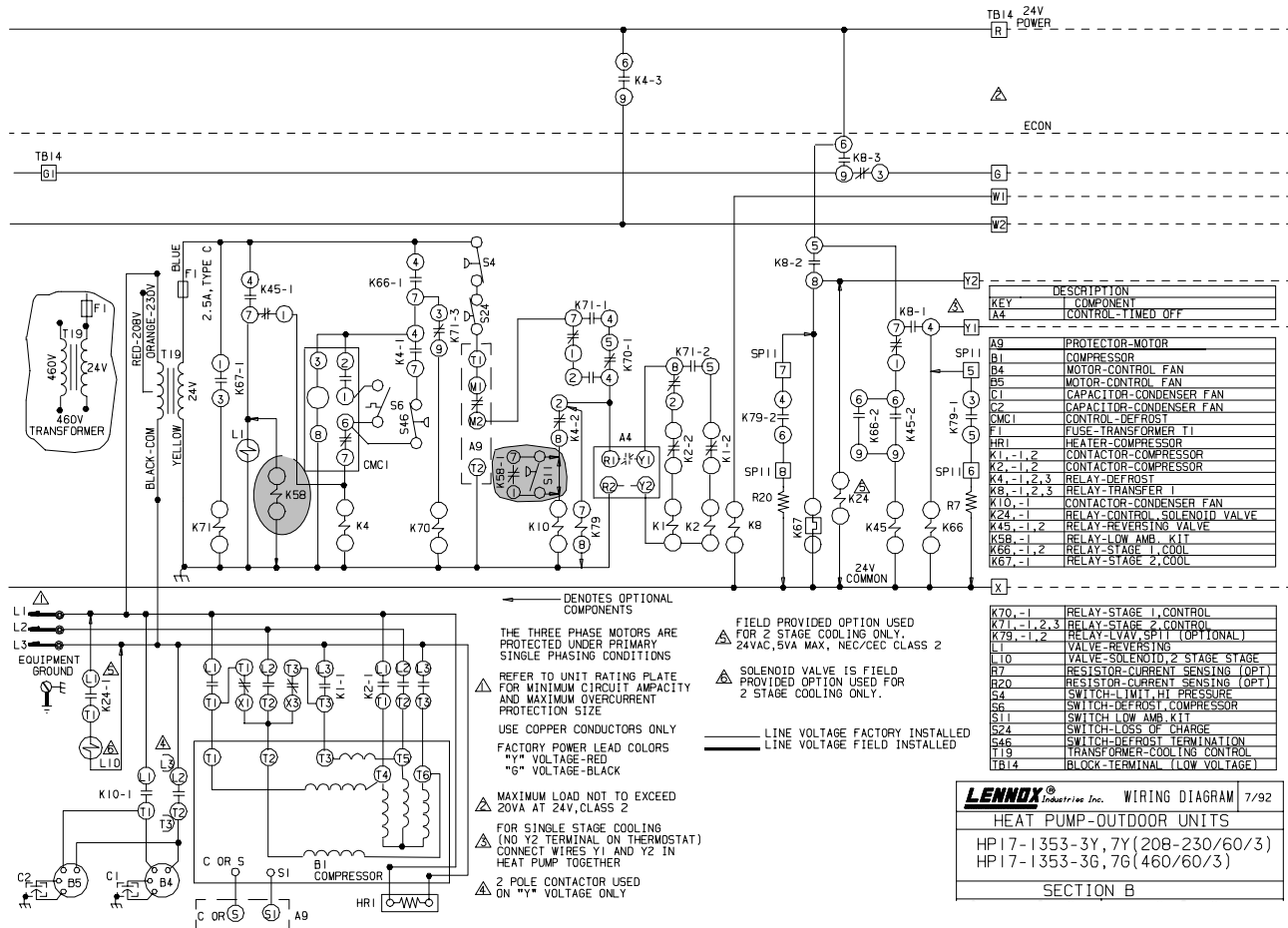

LENNOX® Industries Inc. WIRING DIAGRAM 7/92

HEAT PUMP-OUTDOOR UNITS

HP17-1353-3Y, 7Y (208-230/60/3)
HP17-1353-3G, 7G (460/60/3)

SECTION B

SEE PICTORIAL FIGURE 5

FIGURE 6

TYPICAL SINGLE-COMPRESSOR PACKAGED HEAT PUMP UNIT WIRING DIAGRAM
 (S11 LOW AMBIENT CONTROL SWITCHES OUTDOOR FAN DIRECTLY)
 CHP16-2 TO 5 TON UNITS

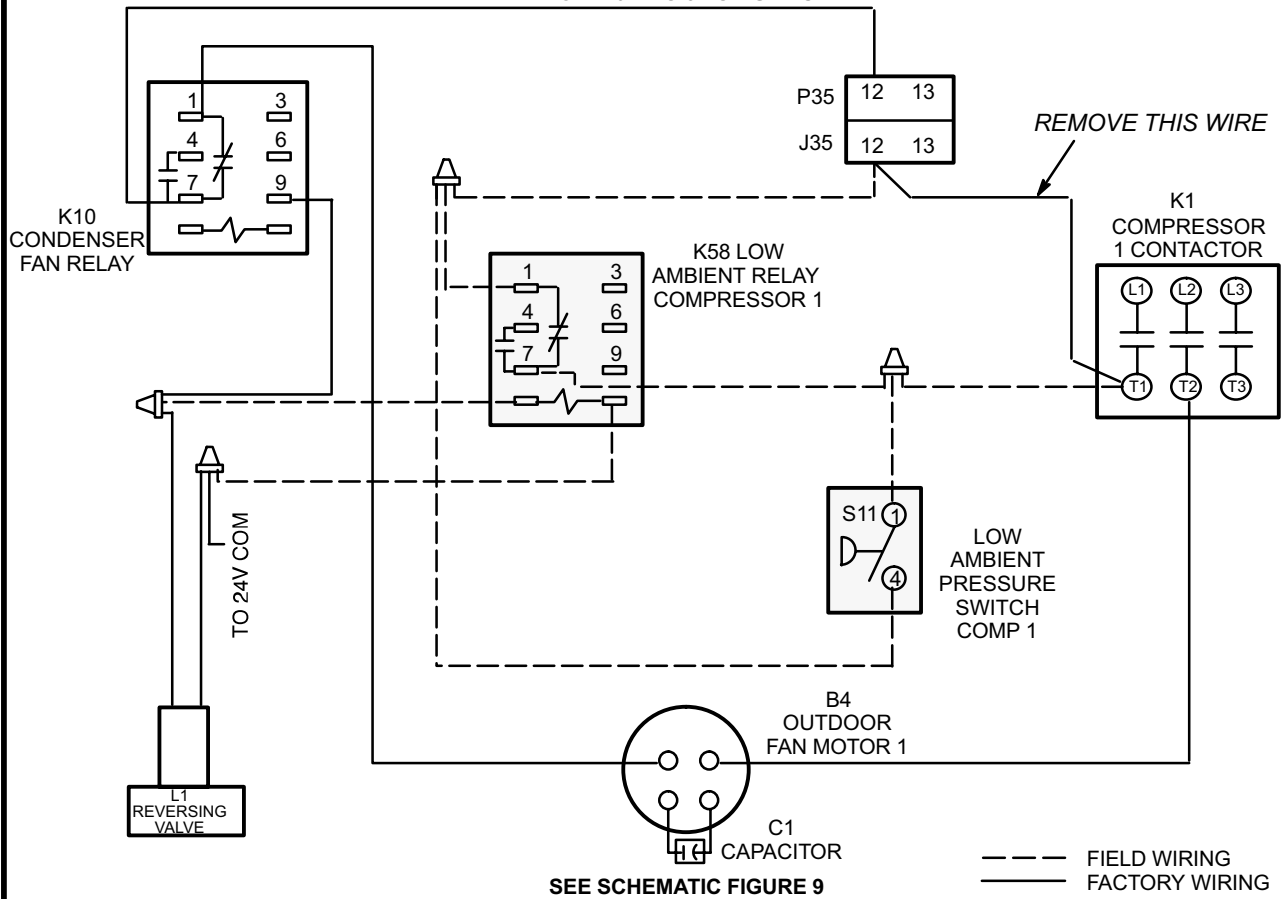

FIGURE 7

TYPICAL SINGLE-COMPRESSOR LOW AMBIENT WIRING FOR UNITS CONTAINING
 68J29 AND 68J84 DEFROST BOARDS (CMC1)

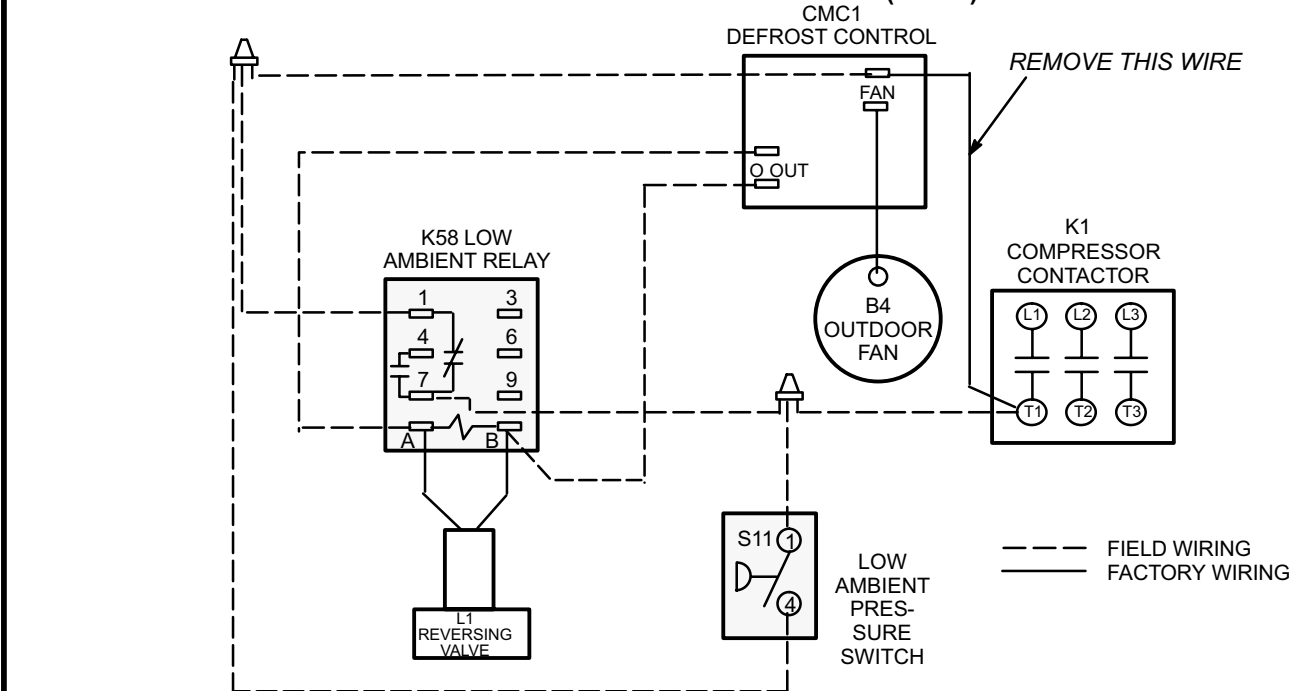
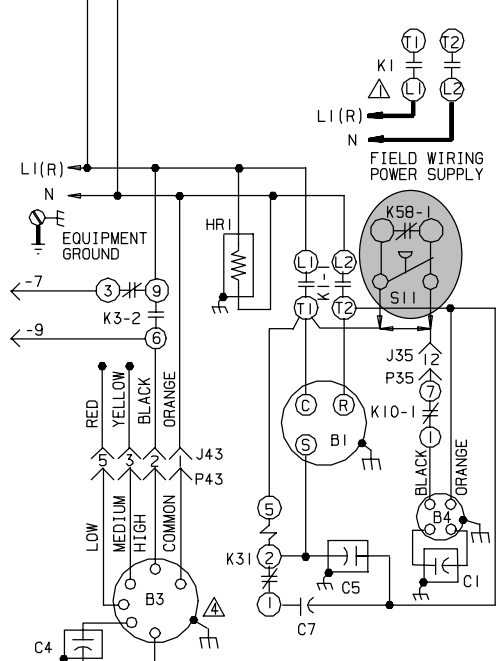
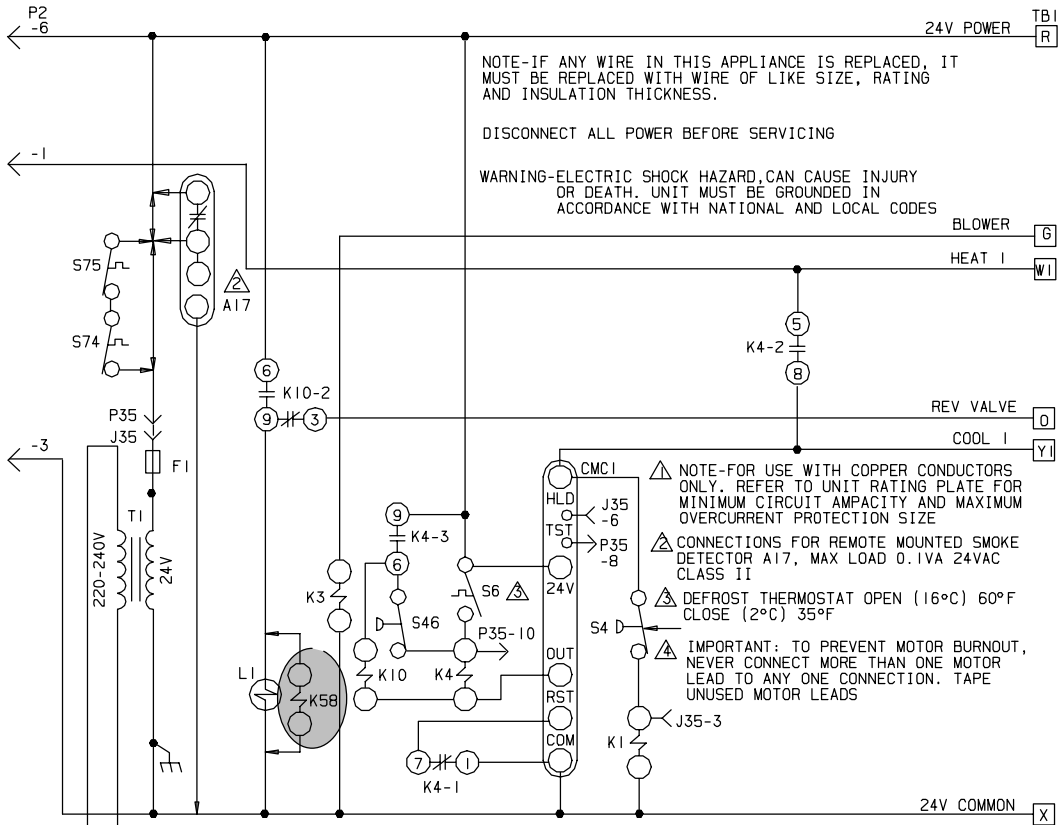

FIGURE 8

TYPICAL SINGLE-COMPRESSOR PACKAGED HEAT PUMP UNIT WIRING DIAGRAM (S11 LOW AMBIENT CONTROL SWITCHES OUTDOOR FAN DIRECTLY)

CHP16-2 TO 5 TON UNITS



DENOTES OPTIONAL COMPONENTS

| KEY | DESCRIPTION |
|--------------|--------------------------------------|
| A17 | (SEE NOTE 2) |
| B1 | COMPRESSOR |
| B3 | MOTOR-BLOWER |
| B4 | MOTOR-OUTDOOR FAN |
| C1 | CAPACITOR-OUTDOOR FAN |
| C4 | CAPACITOR-BLOWER MOTOR |
| C5 | CAPACITOR-COMPRESSOR |
| C7 | CAPACITOR-COMPRESSOR, HARD START |
| CMC1 | TIMER-DEFROST, COMPRESSOR |
| F1 | FUSE-TRANSFORMER T1 |
| J35 | JACK-TEST |
| J43 | JACK-BLOWER MOTOR |
| K1, -1 | CONTACTOR-COMPRESSOR |
| K3, -1, 2 | CONTACTOR-BLOWER |
| K4, -1, 2, 3 | RELAY-DEFROST |
| K10, -1, 2 | RELAY-OUTDOOR FAN |
| K31 | RELAY-HARD START KIT |
| K58, -1 | RELAY-LOW AMBIENT KIT |
| L1 | VALVE-REVERSING |
| P2 | PLUG-ELECTRIC HEAT |
| P35 | PLUG-TEST |
| P43 | PLUG-BLOWER MOTOR |
| S4 | SWITCH-LIMIT, HI PRESS(MANUAL RESET) |
| S6 | THERMOSTAT-DEFROST |
| S11 | SWITCH-LOW PRESS, LOW AMB KIT |
| S46 | SWITCH-PRESSURE, DEFROST |
| S74 | SWITCH-FIRESTAT |
| S75 | SWITCH-FIRESTAT 2 |
| T1 | TRANSFORMER-CONTROL |
| TB1 | TERMINAL STRIP-LOW VOLTAGE |

LINE VOLTAGE FIELD INSTALLED

| | | |
|---------------------------------|----------------|------|
| LENNDX ® Industries Inc. | WIRING DIAGRAM | 6/92 |
| HEAT PUMPS-PACKAGED | | |
| CHP16H-261-1, 2-T | | |
| 220-240/50/1 | | |
| HEAT PUMP SECTION B25 | | |

SEE PICTORIAL FIGURE 7

FIGURE 9

**S11 LOW AMBIENT CONTROL SWITCHES
OUTDOOR FAN DIRECTLY (LINE VOLTAGE)
SINGLE PHASE**

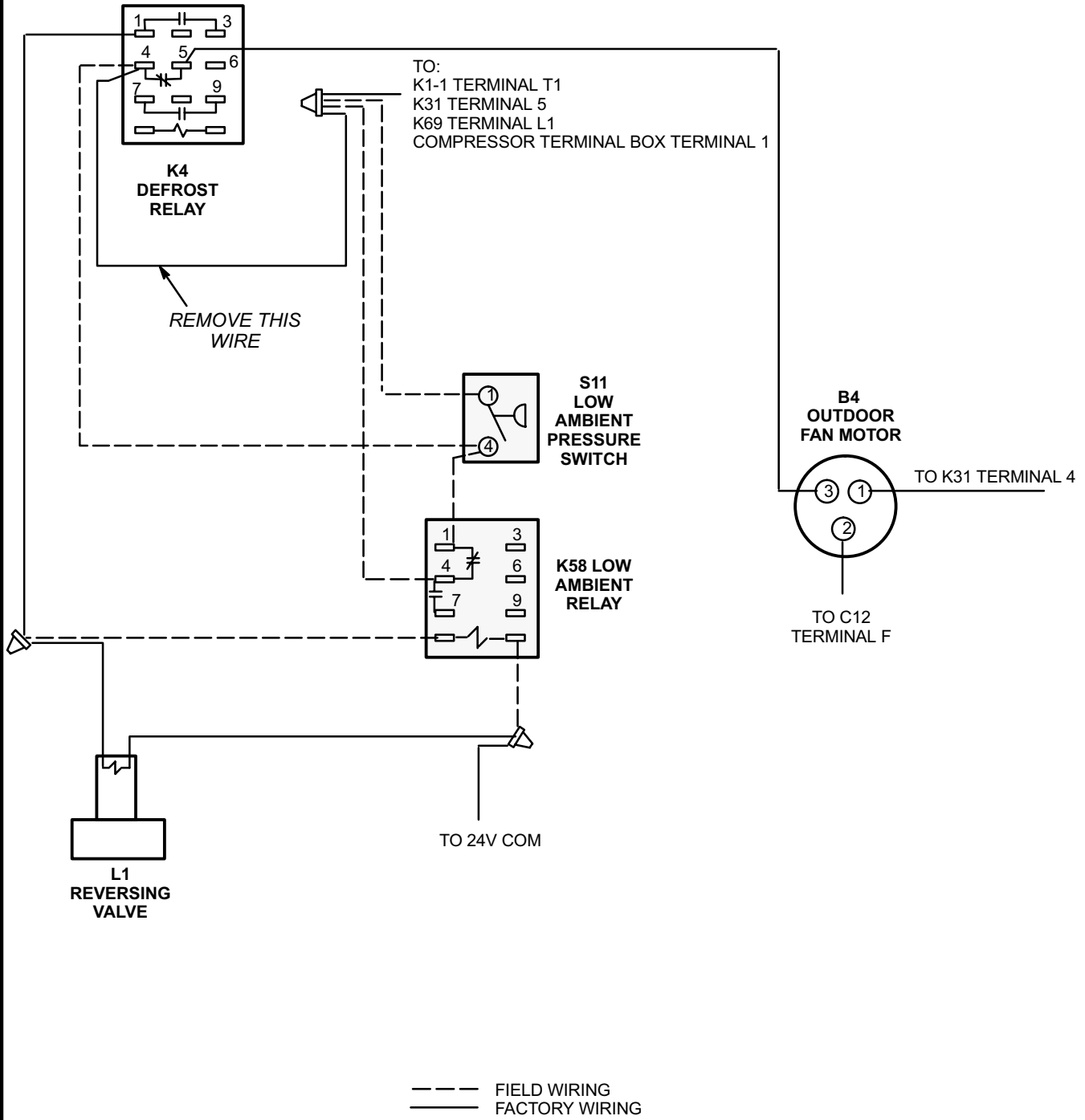

SEE SCHEMATIC FIGURE 11

FIGURE 10

TYPICAL SINGLE-COMPRESSOR, TWO-STAGE, SINGLE PHASE HEAT PUMP UNIT WIRING DIAGRAM (S11 Low Ambient Control Switches Outdoor Fan Directly)

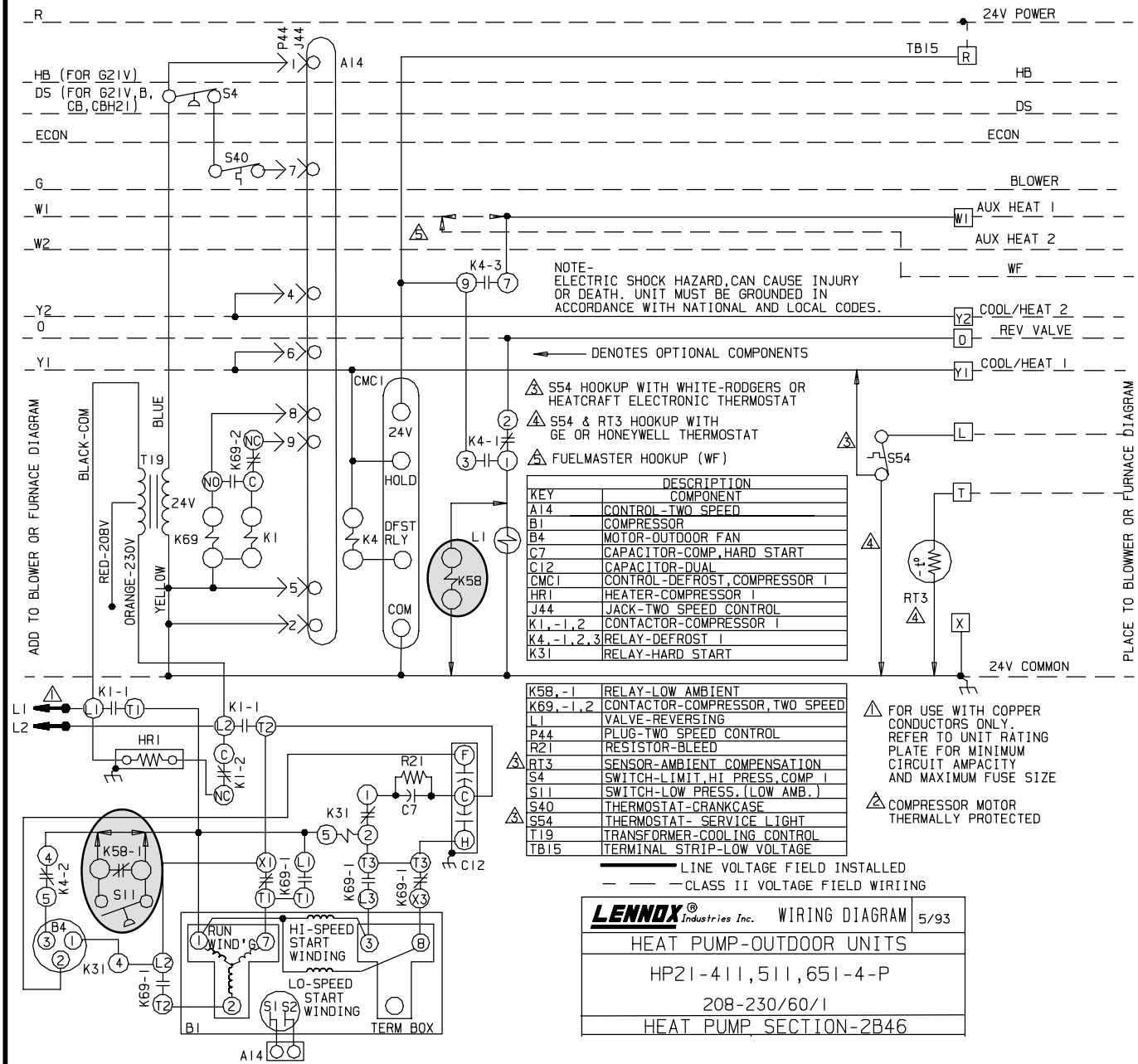

SEE PICTORAL FIGURE 10

FIGURE 11

**S11 LOW AMBIENT CONTROL SWITCHES
 OUTDOOR FAN DIRECTLY (LINE VOLTAGE)
 THREE PHASE**

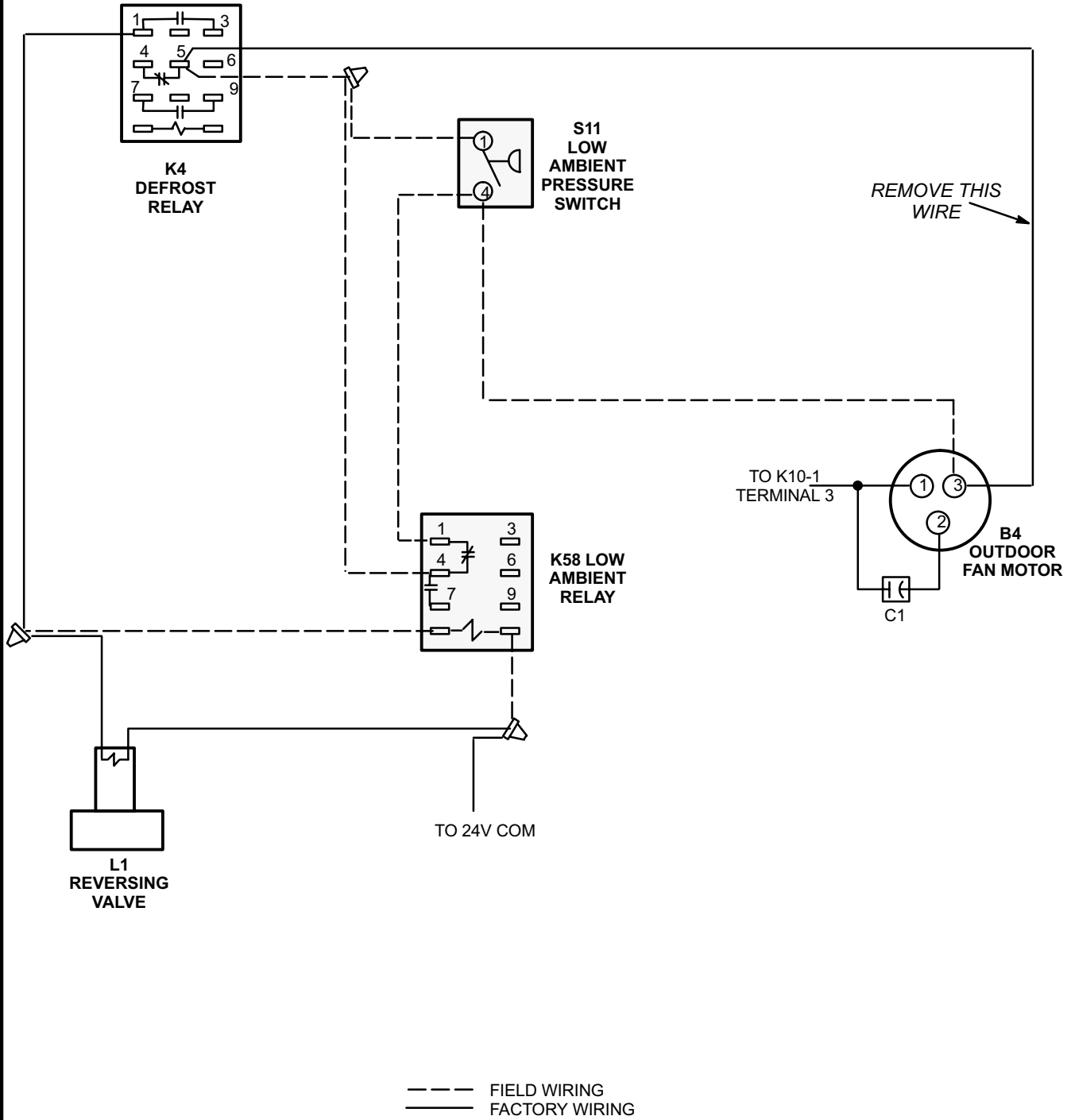

SEE SCHEMATIC FIGURE 13

FIGURE 12

TYPICAL SINGLE-COMPRESSOR, TWO-STAGE, THREE PHASE HEAT PUMP UNIT WIRING DIAGRAM (S11 Low Ambient Control Switches Outdoor Fan Directly)

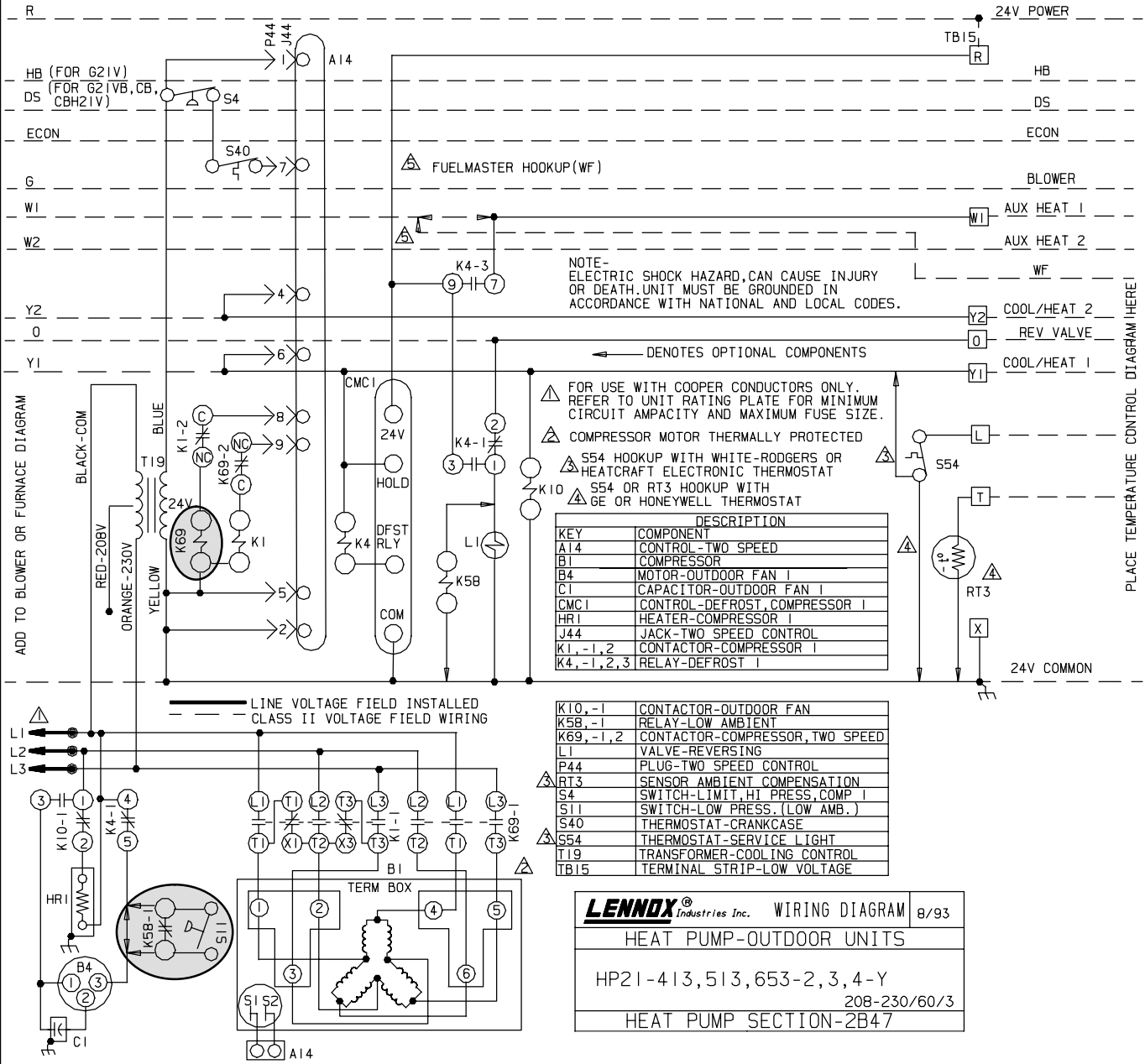

SEE PICTORAL FIGURE 12

FIGURE 13