



Chiller HWA-C HWA-H HWA-F



Index

1.	General description of the application	5
1.1	Types of units controlled	5
1.2	Maximum number of compressors.....	5
1.3	Types of regulation	5
1.4	Condensation	5
1.5	Compressor operating turnover	5
1.6	Defrosting modes (HWA-H model)	5
1.7	Safety devices on each cooling circuit.....	5
1.8	System safety features	5
1.9	Optional accessories.....	5
2	Regulation logic.....	6
2.1	Inlet temperature regulation	6
2.1.1	PROPORTIONAL regulation	6
2.1.2	PROPORTIONAL + INTEGRAL Regulation.....	6
2.1.3	Setpoint.....	6
2.2	Compressor times and configuration	7
2.2.1	Compressor operation turnover.....	7
2.2.2	Minimum compressor "ON" time.....	7
2.2.3	Minimum compressor "OFF" time.....	8
2.2.4	Delay between two start-up requests	8
2.2.5	Delay between two successive start-ups of the same compressor.....	8
2.3	Condensation Control	9
2.3.1	Settings.....	9
2.3.2	High pressure alarm	10
2.3.3	Prevent function.....	11
2.4	Defrost control (Heat pump model).....	11
2.5	Antifreeze regulation	12
2.6	Freecooling operating logic.....	13
2.6.1	Free cooling condition	13
2.6.2	Fan speed in free cooling mode	13
2.6.3	Combined operating mode: mechanical cooling + free cooling.....	14
2.6.4	Condensation coil capacity control	14
2.6.5	High-pressure safety function.....	14
2.6.6	Antifreeze function	14
2.6.7	Free Cooling Alarm.....	15
2.6.8	3-way valve maintenance function	15
3	Start-up and configuration	16

3.1	Terminal with keyboard and display	16
3.2	Display	16
3.2.1	Moving around inside the masks	16
3.3	Keyboard.....	17
3.4	Starting up the unit for the first time.....	18
3.5	General description of menus	18
4	Alarm management.....	19
4.1	Alarm table.....	19
4.2	Alarm history	20
5	Menu tree structure	21
5.1.1	Main menu	21
5.1.2	Maintenance menu	21
5.1.3	I/O Menu	24
5.1.4	Clock menu.....	25
5.1.5	Setpoint Menu.....	25
5.1.6	User menu	25
5.1.7	Manufacturer menu	27
5.1.8	Alarm menu	29
6	Application setting parameters	31
6.1	Maintenance menu	31
6.2	Setpoint menu.....	31
6.3	User menu.....	31
6.4	Manufacturer menu.....	32
7	Architecture of the control system	34
7.1	Microprocessor layout.....	34
7.2	Description of inputs and outputs	35
7.2.1	Chiller only cooling model.....	35
7.2.2	Heat pump chiller.....	36
7.2.3	Freecooling chiller.....	37
7.3	Optional boards.....	38
7.3.1	RS485 serial board for supervisory function	38
7.3.2	Clock board.....	38
7.4	Technical data.....	39

1. General description of the application

The operation of HWA-C units, HWA-H units (heat pump model) and HWA-F (freecooling model) is managed by application software installed in the controller on the unit. The main features of the application program are described below.

1.1 Types of units controlled

The software is designed to control air/water chiller units (HWA model), models with operation as a heat pump (HWA-H model) and model with freecooling action (HWA-F model).

1.2 Maximum number of compressors

Available compressors configurations:

- 1 compressor, 1 cooling circuit
- 2 compressors, 2 cooling circuits
- 4 compressors, 2 cooling circuits

1.3 Types of regulation

Proportional regulation or proportional regulation with integral action on the evaporator input temperature. Possibility of adjusting the setpoint remotely.

1.4 Condensation

Condensation can be carried out in the following modes:

- on/off based on compressor operation (without pressure transducers);
- on/off or modulating based on the pressure transducer reading (when high pressure transducers are enabled);

1.5 Compressor operating turnover

Turnover of all compressors according to a FIFO logic.

Selection of balanced turnover of all compressors according to a FIFO logic.

1.6 Defrosting modes (HWA-H model)

Defrosting can be simultaneous or separated among the circuits.

1.7 Safety devices on each cooling circuit

- High pressure (pressure switch).
- Low pressure (pressure switch).
- Compressor thermal switch.

1.8 System safety features

- Serious alarm (shuts the whole unit down)
- Evaporator flow switch (shuts the whole unit down).
- Pump thermal switch
- Condensation fan thermal switch
- Remote on/off input without alarm signalling.
- Freecooling fault alarm (HWA-F model)

1.9 Optional accessories

- Supervision by means of RS485 serial board.
- Alarm history building with clock board.

2 Regulation logic

2.1 Inlet temperature regulation

Inputs used:

- Evaporator inlet water temperature

Parameters used:

- Regulation setpoint
- Proportional band for input temperature regulation.
- Type of regulation (proportional or proportional + integral)
- Integration time (if proportional + integral regulation is enabled)

Outputs used:

- Compressor On/Off

Regulation diagram with two compressors:

2 = C1 e C2 On
1 = C1 On e C2 Off
0 = C1 e C2 Off

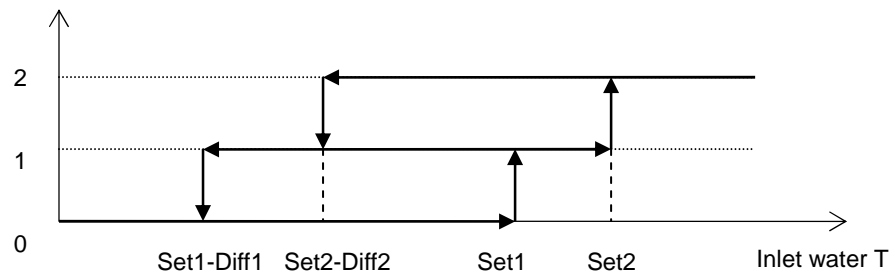

Figure 1: Regulation diagram with two compressors

2.1.1 PROPORTIONAL regulation

On the basis of the setpoint entered from the mask (ref. mask *M_SETPOINT5*, page 25), if the secondary setpoint or the remote setpoint is active, a proportional band is calculated with a width equal to the differential set from the mask (ref. mask *M_USER25*, page 25).

Inside this band the positions of the device regulation steps are calculated according to the number of compressors.

2.1.2 PROPORTIONAL + INTEGRAL Regulation

Proportional + integral regulation uses the same parameters as simple proportional regulation; it calculates the steps at which the devices are cut in on the basis of the setpoint, the differential and the integration time set from the mask (ref. mask *M_USER20*). The integral action is doubled if the conditions have not changed after the time set.

2.1.3 Setpoint

Main Setpoint

From the mask *M_SETPOINT15* it is possible to set the main setpoint for the summer (HWA-C) and winter (HWA-H) operating modes.

Secondary Setpoint

From the mask *M_MANUF28* it is possible to select the ID 14 digital input configuration for the management of serious alarms or the secondary setpoint. If secondary setpoint management is selected, the *M_SETPOINT10* is enabled for the setting of the summer and winter setpoint controlled by the digital input. With the digital input open, the setpoint entered from the *M_SETPOINT5* mask will be used; with the digital input closed, the secondary setpoint will be used.

An "R" will appear in the upper right corner of the setpoint masks to indicate the activation of the secondary setpoint.

Remote Setpoint

From the M_USER24 mask it is possible to enable the remote setpoint function that uses an analog input. The signal will be converted between the minimum and maximum values set from the mask. The read value will then be added to the setpoint value resulting from the secondary setpoint management.

2.2 Compressor times and configuration

The unit enables the control of hermetic scroll compressors. Mask M_MANUF20 (see 5.1.7 Manufacturer menu

page 27) is used for configuration purposes; from the mask it is necessary to set the number of compressors per circuit and the number of circuits.

Most of the operations performed by the pCO¹ are conditioned by programmable delays. Some of them serve to delay the triggering of some alarms or to assure the proper functioning of the compressors, thereby lengthening their lives and guaranteeing system stability.

2.2.1 Compressor operation turnover

The compressor operation turnover makes it possible to balance the number of hours of operation and the number of starts-stops of the various compressors. The turnover is carried out according to a FIFO logic, meaning that the first compressor to start will also be the first to stop. During the initial start-up period this behaviour may result in big differences between the operating hours of the compressors. However, at full capacity operation the number of hours will be very similar.

Management without FIFO turnover (with four compressors):

- Start-up: C1,C2,C3,C4.
- Stop: C4,C3,C2,C1.

Management with FIFO turnover (with four compressors):

- Start-up: C1,C2,C3,C4.
- Stop: C1,C2,C3,C4.

If the turnover function is enabled it is possible to select the balanced turnover, which always follows a FIFO logic, i.e. the odd devices are activated first and then the even ones:

- Start-up: C1, C3, C2, C4.
- Stop: C1, C3, C2, C4.

2.2.2 Minimum compressor "ON" time

(ref. mask M_MANUF40, 5.1.7 see Manufacturer menu, page 27)

This determines the minimum time (in seconds) the devices must continue running: therefore, once activated they must stay on for the set length of time.

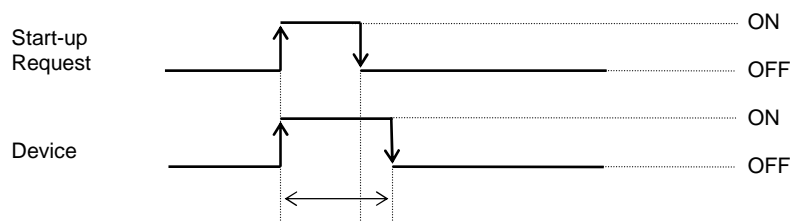

Figure 2: Minimum compressor on time

2.2.3 Minimum compressor “OFF” time

(ref. mask *M_MANUF40*, 5.1.7 see Manufacturer menu , page 27)

This determines the minimum time the devices must remain off. After they are shut off, the compressors cannot start up again until the set time has elapsed.

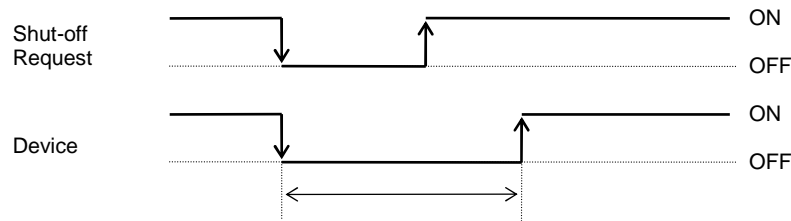

Figure 3: Minimum compressor off time

2.2.4 Delay between two start-up requests

(ref. mask *M_MANUF45*, 5.1.7 see Manufacturer menu , page 27)

This determines the minimum time that must elapse between two device starts irrespective of the read measurement or setpoint. This parameter makes it possible to limit the number of starts per hour. If, for instance, the maximum allowed number of starts per hour is 10, setting a value of 360 seconds will ensure that this limit is complied with.

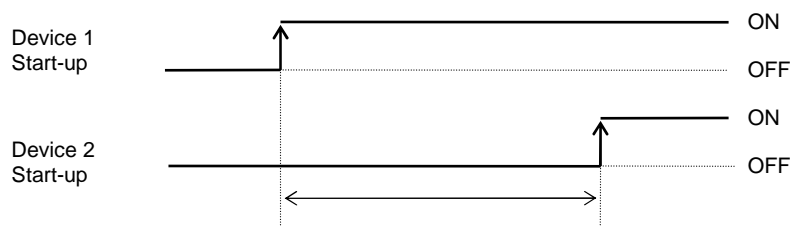

Figure 4: Delay between two start-up requests

2.2.5 Delay between two successive start-ups of the same compressor

(ref. mask *M_MANUF45*, 5.1.7 see Manufacturer menu , page 27)

This establishes the minimum time that must elapse between two starts of the same device, irrespective of the read measurement or the setpoint. This parameter makes it possible to limit the number of starts per hour. If, for instance, the maximum allowed number of starts per hour is 10, setting a value of 360 seconds will ensure that this limit is complied with.

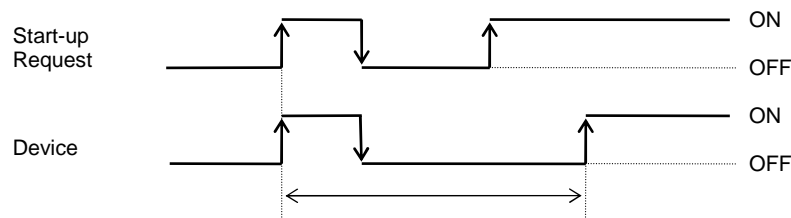

Figure 5: Delay between two successive start-ups of the same compressor

2.3 Condensation Control

Condensation can be regulated according to the following modes

- on/off based on compressor operation (without pressure transducers);
- on/off or modulating based on the pressure transducer reading (when high pressure transducers are enabled);

Inputs used:

- Condensing pressure probe of first circuit (B1 analog input)
- Condensing pressure probe of second circuit (B2 analog input)

Parameters used:

- Condensation control selection: none/pressure
- Number of fans
- Type of condensation coil (Single / Separate)
- Condensation Setpoint
- Condensation Differential
- Enabling of prevent function
- Prevent Setpoint
- Prevent Differential
- Delay in device reactivation after triggering of prevent function
- Output voltage relative to minimum inverter speed
- Output voltage relative to maximum inverter speed
- Inverter speed-up time

Outputs used:

- Fans (NO9 digital output)
- Fan speed regulation (Y1 analog output)

2.3.1 Settings

For condensation it is necessary to set:

- the type of regulation by means of the "Abilit." (Enable) code in the *M_MANUF50* mask (see page 27). The selection is made between *NO / TEMPERATURE* for choosing regulation either on the basis of the compressor status or on the basis of the values read by the pressure transducers;
- the type of devices used by specifying the "Tipo" (Type) code in the *M_MANUF50* mask (see page 27). The selection is made between *INVERTER / GRADINI (STEPS)* for choosing either the modulating or the ON/OFF type regulation;
- the number of fans connected if step regulation is selected, by entering a value for "N. Ventilatori" (No. of fans) in the *M_MANUF55* mask (see page 27);
- the type of condenser by means of the "Condensatore" (Condenser) code in the *M_MANUF55* mask (see page 27). The selection is made between *SINGLE / SEPARATE*;
- the condensation setpoint and the differential, to be entered in the *M_MANUF60* mask (see page 27). The setting generates a proportional band (setpoint / setpoint + differential) from which it calculates the position of the various fan activation steps or the modulating output value according to the selection made;
- the minimum and maximum speeds of the inverter by specifying the "Max.velocità" (Max. Speed), "Min.velocità" (Min. Speed) codes in the *M_MANUF70* mask (see page 27); the proportional action of the modulating output is calculated within the range of these values;
- the minimum operating time of the inverter by specifying the "Tempo min ON" (Min. ON Time) code on the *M_MANUF70* mask (see page 27);
- enabling of the prevent function by means of the "Abilit." Prevenzione ALTA PRESSIONE ("Enable" HIGH PRESSURE prevention) code in the *M_MANUF80* mask (see page 27). The prevent function will be executed according to the modes specified below in this section;
- the prevent setpoint and differential (ref. *M_MANUF80* mask, see page 27);
- the delay in compressor restarts after triggering of the prevent function (ref. *M_MANUF81* mask page 27);

Condensation on/off based on compressor operation

If *NO* is selected in the *M_MANUF50* mask (see page 27) the fans' operation will depend only on the operation of the compressors.

Condensation on/off based on pressure sensor

If *PRESSURE* is selected in the *M_MANUF50* mask (see page 27), the fans' operation will depend only on the pressure read by the pressure sensors, according to the selected setpoint and differential band. With pressure values lower or equal to the setpoint all fans will be turned off; with pressure values higher than the setpoint + differential band, all fans will be turned on. It will be possible to select the condensation function either with a single coil or separate coil. In the case of single coil condensation, the fans will be controlled by the highest pressure; with separate coil condensation each pressure sensor will control its respective fan.

Modulating condensation based on pressure sensor

If this type of condensation is chosen, the fans will be controlled in a manner proportional to the readings of the pressure sensor. It will be possible to select the condensation function either with a single or separate coil. In the case of a single coil, the inverter will be controlled by the highest pressure; with a separate coil each pressure sensor will control its respective inverter. The graph below shows fan operation after the setpoint and the differential band have been set.

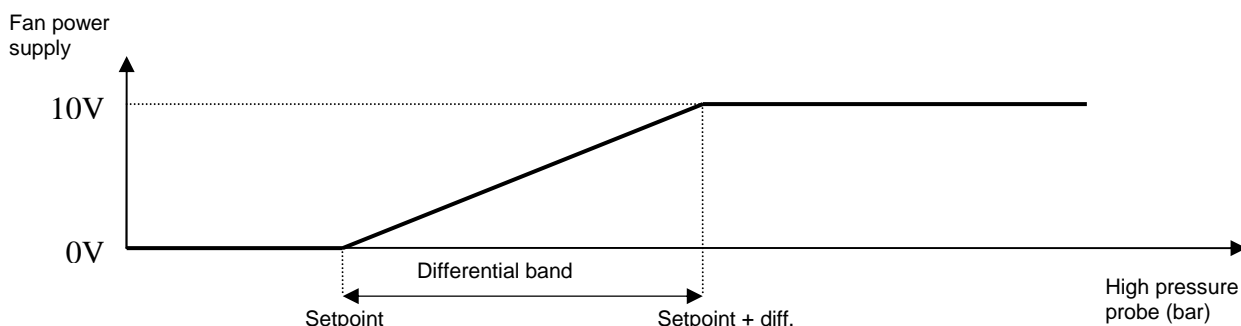

Figure 6: Modulating condensation based on pressure sensor

If the minimum fan speed is assigned to a power supply value higher than 0V (the graph shows a case where the minimum speed has been assigned to 3V) a 1 bar hysteresis (default) is applied in order to avoid repeated start-ups and stops.

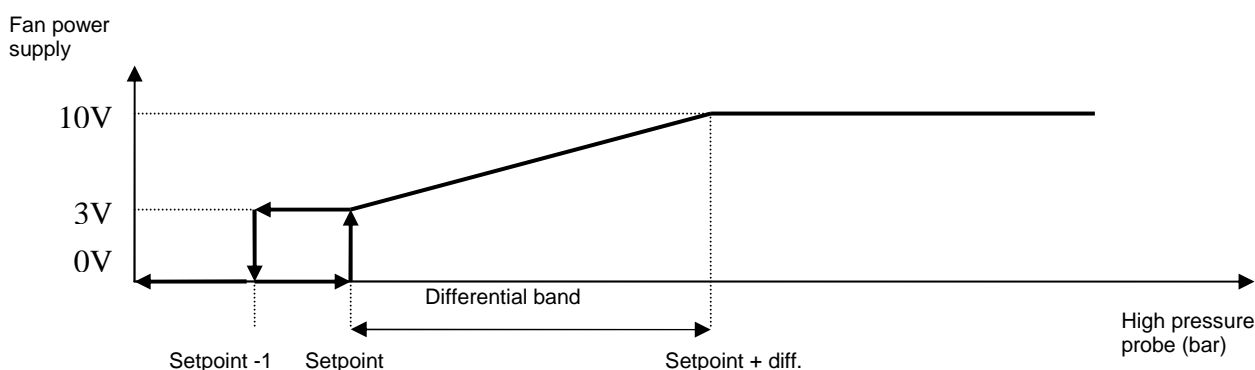

Figure 7: Modulating condensation with 1 bar Hysteresis

2.3.2 High pressure alarm

If the pressure value exceeds the high pressure alarm setpoint selected in the *M_MANUF85* mask (see page 27) an alarm will be signalled and the circuit concerned will be deactivated. The alarm will turn off when the pressure drops below the setpoint – differential value.

2.3.3 Prevent function

Selecting this function requires access to a factory-set password. It serves to prevent circuits from being blocked due to the triggering of the high pressure alarm. It can be set only on units having two compressors per circuit.

Setpoint and differential values must be selected from the *M_MANUF80* mask (see page 27). The prevent function shuts off the compressors, thereby dividing the power supplied to the cooling circuit. When the condensation pressure exceeds the prevent function activation value (setpoint), the function is triggered and remains active until the value detected goes below the prevent function deactivation value (setpoint – differential). At this point a delay is activated (settable from the *M_MANUF81* mask on page 27) which lengthens the prevent action, thus delaying any restart of the compressors.

2.4 Defrost control (Heat pump model)

Inputs used:

- Condensing pressure probe of first circuit (B1 analog input)
- Condensing pressure probe of second circuit (B2 analog input)

Parameters used:

- Inputs used for defrosting
- Defrosting modes (simultaneous / separate)
- Start defrost setting
- End defrost setting
- Defrost delay time
- Maximum defrost time
- Drip time
- Reverse cycle with compressors off (No / Input / Output / Input-Output)

Outputs used:

- Compressor 1
- Compressor 2
- Compressor 3
- Compressor 4
- Reversing solenoid valve – cycle 1
- Reversing solenoid valve – cycle 2
- Fans

The defrosting function requires the setting of some parameters protected by a factory-set password (ref. *M_MANUF130* mask page 27), i.e.:

- *PRESSURE* defrosting probe;
- Defrosting mode (*SIMULTANEOUS* / *SEPARATE*);
- Cooling cycle reverse with compressors turned off (*NO* / *INPUT* / *OUTPUT* / *INPUT-OUTPUT*);

as well as some parameters protected by a user password (ref. *M_USER50* / *55* mask – see page 27), i.e.:

- start/end defrost threshold;
- defrost activation delay time;
- maximum defrost time;
- drip time at the end of defrosting cycle;

Defrosting of one circuit under pressure control:

The defrosting cycle starts when the coil temperature/pressure remains below the start defrost threshold for a total time ($t1+t2+t3$) equal to the defrost delay time and if at least one compressor of the circuit concerned is on.

- compressors are or are not turned off according to the selection made from the mask and the cooling cycle is reversed by means of the 4-way valves.
- the fans are forced into the OFF mode.

The circuit terminates the defrosting cycle when the threshold is exceeded, i.e. when the temperature/pressure value exceeds the end defrost setpoint or when the maximum time set from the mask has elapsed if the temperature/pressure value has not exceeded the end defrost setpoint.

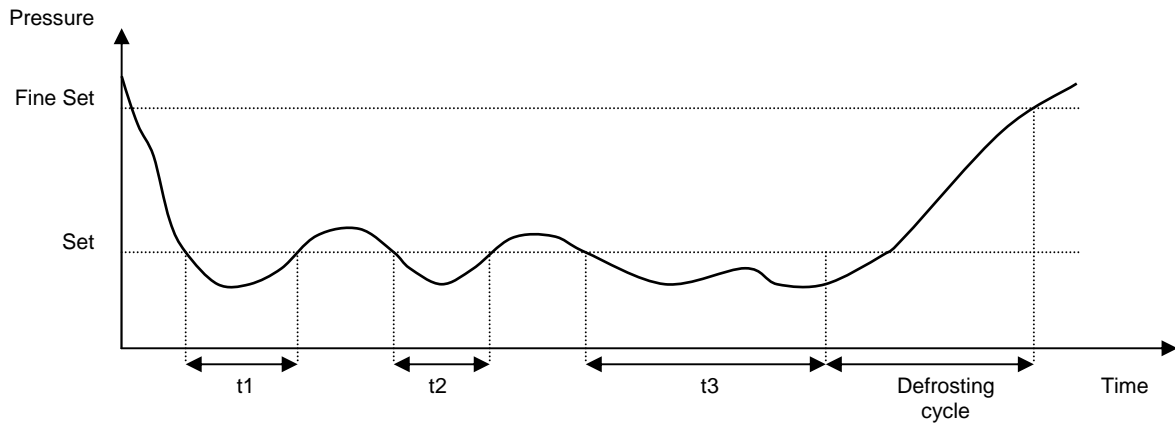

Figure 8: Defrosting cycle

Simultaneous defrosting mode

Even if only one circuit requires defrosting, all circuits are forced into the defrosting mode. Circuits not requiring defrosting (temperature/pressure higher than the end defrost threshold) stop and remain on standby. As soon as the defrosting cycle has terminated, all the compressors can start up again in the heat pump mode.

Separate defrosting mode

In this defrosting mode each cooling circuit undergoes a defrosting cycle separately. The first circuit requiring defrosting starts a defrosting cycle, whereas the other circuits remain on standby until the first circuit has completed its defrosting cycle, even if they too require defrosting. When the defrosting cycle of the first circuit is finished, the following circuit will be defrosted, while the other circuits wait their turn.

2.5 Antifreeze regulation

Inputs used

- Evaporator outlet water temperature probe.

Parameters used:

- Enabling of outlet line probe;
- Antifreeze alarm setpoint;
- Antifreeze alarm differential;

Outputs used:

- Antifreeze alarm;

Each pCO¹ unit can manage antifreeze regulation provided that the outlet temperature probe is connected and enabled.

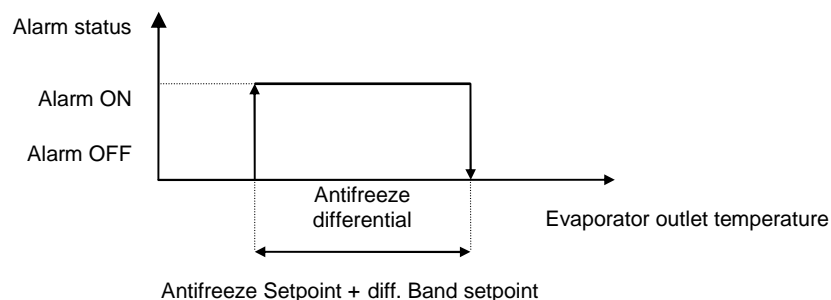

Figure 9: Antifreeze regulation

2.6 Freecooling operating logic

The free cooling function (a feature of HWA-F units) allows the water in the system to be cooled free of charge, thanks to a water heat exchanger cooled by outdoor air. This guarantees:

- production of chilled water at zero cost in wintertime;
- lower operating costs during in-between seasons;
- lower maintenance costs and decreased wear on compressors.

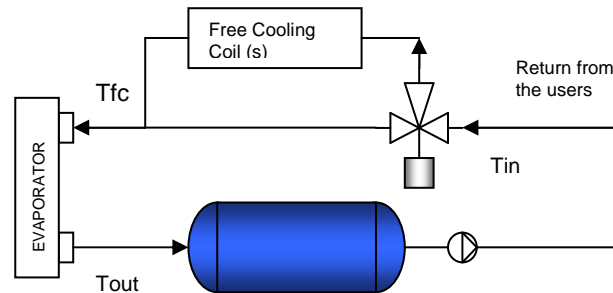

Figure 10: Freecooling circuit

2.6.1 Free cooling condition

Free cooling is enabled if the following conditions are met:

1) FC test:

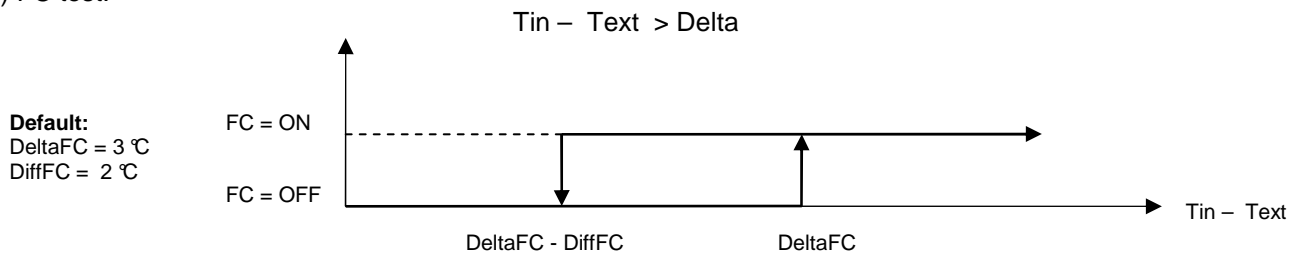

Figure 11: Freecooling condition

2) No FC alarm has been signalled (see section on FC Alarm)

2.6.2 Fan speed in free cooling mode

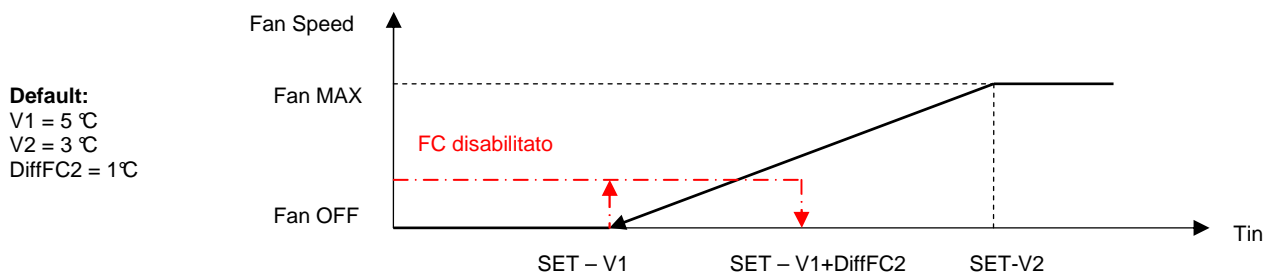

Figure 12: Fan speed

Note 1:

The SET - V1 value cannot be lower than 7°C, otherwise the value will be overridden and set on 7°C.

Note 2:

If Tin falls below the SET-V1 value, FC will be disabled; it will be re-enabled if Tin exceeds the value SET-V1+DIFF.

2.6.3 Combined operating mode: mechanical cooling + free cooling

If the free cooling function does not suffice on its own to provide the desired water temperature values, the unit will switch into the combined operating mode, with the activation of mechanical cooling. The compressors are switched on as adjustments occur in the inlet water temperature, with proportional or proportional + integral control.

In units with two or more steps per circuit, during combined operation they are inhibited and the system works only @ full load.

2.6.4 Condensation coil capacity control

In the combined operating mode, to maintain the condensation temperature at a sufficient level ($T_{cond} \geq 40\text{ }^{\circ}\text{C}$), the heat exchange area is reduced by adjusting the capacity of the condensation coils.

2.6.5 High-pressure safety function

To prevent the occurrence of a high-pressure alarm, the coil capacity control function is deactivated when the condensation pressure reaches the set value.

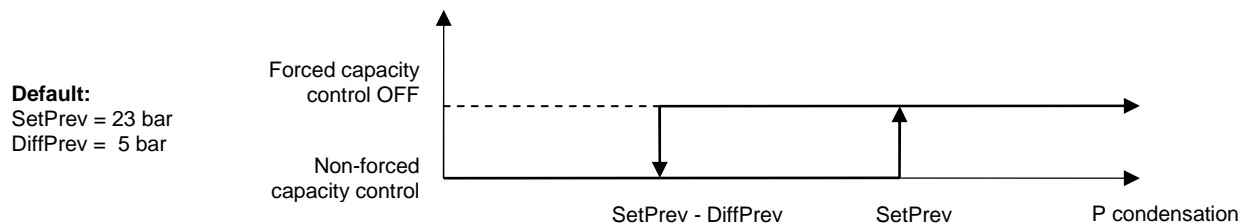

Figure 13: High pressure safety function

2.6.6 Antifreeze function

The switching on of the compressors depends on the water inlet temperature T_{in} ; the free cooling function causes a decrease in the evaporator inlet temperature. To prevent the antifreeze alarm from triggering, a specific function has been implemented. When a cooling step is to be activated, a forecast is made of the evaporator outlet temperature, taking into account the temperature T_{fc} and the thermal differential of the unit. Based on the forecast temperature, it will be decided whether or not to enable the compressor in question to start. The lower limit of the evaporator outlet temperature is equal to the antifreeze temperature setpoint + 1 °C.

Example:

N° Compressors = 2
Delta T = 5 °C
Setpoint = 12 °C
Differential = 4 °C
Antifreeze setpoint = 5 °C → Lower limit of outlet water temp. = 6 °C

Case 1

$T_{in} = 14\text{ }^{\circ}\text{C}$
 $T_{ext} = 0\text{ }^{\circ}\text{C}$
 $T_{fc} = 8\text{ }^{\circ}\text{C}$

T_{out} forecast with compressor on = 5.5 °C

The compressor start is inhibited → $T_{out} = 8\text{ }^{\circ}\text{C}$

Case 2

Tin = 14°C
Text = 3°C
Tfc = 9.5°C

Tout forecast with compressor on = 7 °C

The compressor start is enabled → Tout = 7°C

2.6.7 Free Cooling Alarm

The free cooling alarm system has been implemented for the purpose of identifying a malfunctioning of the free cooling valve. It is based on the readings of the temperature sensors and the logical free cooling status. An alarm will be signalled if any of the following conditions occur:

1) If FC = ON, a free cooling alarm will exist if:

$$| T_{in} - T_{fc} | < \Delta 1$$

Default:
Delta1 = 0.5°C

If free cooling is on and the absolute value of the difference between Tin and Tfc is very low, the free cooling valve may be jammed in the closed position, thereby inhibiting the free cooling function.

2) If FC = OFF, a free cooling alarm will exist if:

$$T_{fc} - T_{in} > \Delta 2$$

Default:
Delta2 = 1°C

If free cooling is off and the difference between Tfc and Tin is greater than Delta2, the free cooling valve could be jammed in the open position, thereby causing an increase in temperature Tfc,

Note 1

The free cooling alarm function is disabled if the fan speed is less than 70% of the maximum speed.

2.6.8 3-way valve maintenance function

The valve used to divert water inside the free cooling exchanger is of the sector type and to ensure that it performs efficiently over time, it must be opened and closed when no switchover operations have taken place during the set interval of time.

Note 1

During the forced rotation stage, the free cooling alarm is inhibited.

3 Start-up and configuration

3.1 Terminal with keyboard and display



Figure 14: Terminal

The user *terminal* is shown in the picture. It consists of a 4 line x 20 column LCD, keyboard and LEDs controlled by a microprocessor: from the terminal the user can set the control parameters (setpoint, differential band, alarm thresholds, etc.) and perform fundamental operations.

The following main operations can be performed via the terminal:





- initial machine configuration;
- modification of main operating parameters;
- display of machine status and of all measured data;
- display of the alarms detected and a 'buzzer' (that can be disabled);

The terminal and the pCO¹ controller are connected via a 6-way telephone cable. **This connection is not essential for standard controller operation.**

3.2 Display

The display used is of the 4 line x 20 column LCD type. The data and information regarding operation alternate as successive windows called *masks*. It is possible to move around inside the masks using the terminal keys as described below:

3.2.1 Moving around inside the masks

If the cursor is positioned in the top left-hand corner (Home) pressing the   keys allows the user to access the successive masks associated with the selected branch. If a mask includes fields for setting values, pressing the *ENTER* key will cause the cursor to move into these fields. Once a parameter setting field is reached it is possible to change its value, within the set limits, by pressing the   keys. Once the desired value has been set, pressing the *ENTER* key again will store it in the memory.

3.3 Keyboard

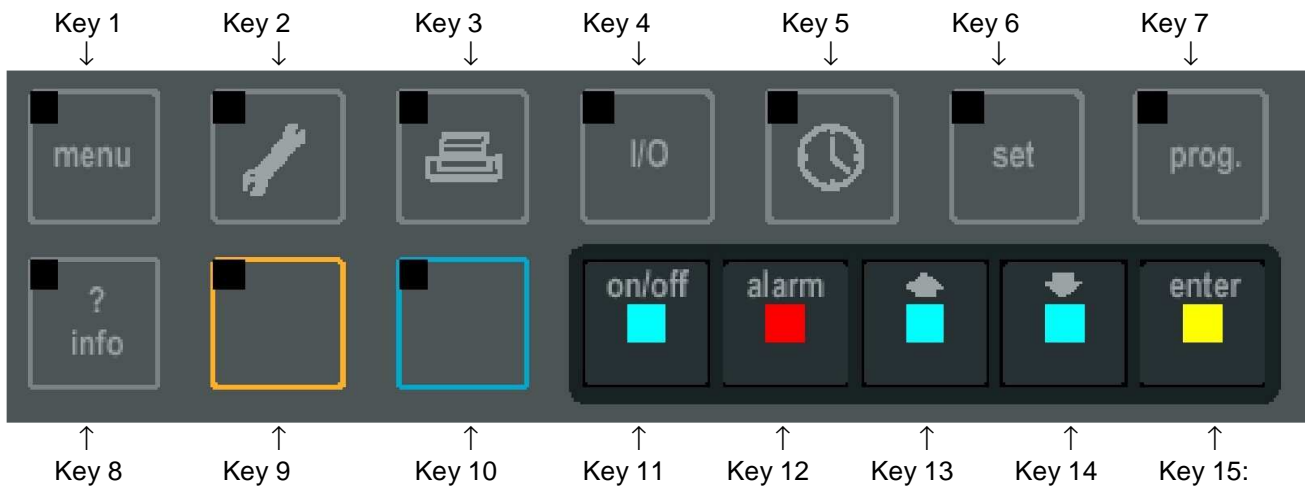

Key 1: Accesses the mask displaying the fundamental machine data and status.

Key 2: Accesses device maintenance data (hours of service of a device and hour meter reset, alarm history, manual operating procedure).

Key 3: Function not active.

Key 4: Accesses the masks displaying digital and analog input/output statuses.

Key 5: Accesses the clock programming mask (if a clock board is included).

Key 6: Accesses the setpoint display / setting masks.

Key 7: Accesses the user parameter programming masks (thresholds, delays etc.).

Key 1 + Key 7: By pressing these keys at the same time the user accesses the machine configuration (number of devices connected to the pCO1, programming of the full scale values, etc.).

Key 8: Displays data concerning the software used.

Key 9: For selecting the winter mode (HWA-H model, not available on the HWA model).

Key 10: For selecting the summer mode (HWA-H model, this mode is always active on the HWA model).

Key 11: This key allows the unit to be switched on and off. The green LED illuminating the key indicates the unit status.

Key 12: This key is used for displaying alarms, resetting them manually and silencing the buzzer. If the key is lit (red LED) it means that at least one alarm has been detected. Pressing the key once will silence the buzzer and cause a mask to appear which describes the alarm that is active. Pressing a second time will reset the alarm signalling function.

Key 13: this key enables the setting of control parameters as well as movement from one mask to another (not backlit).

Key 14: this key enables the setting of control parameters as well as movement from one mask to another (not backlit).

Key 15: used for moving the cursor inside the masks and saving parameter settings. The key is constantly backlit (yellow light) to indicate that the power supply is on.

NOTE: The LEDs alongside each key come on when the respective function is activated.

3.4 Starting up the unit for the first time

When the microprocessor is connected to the power supply, the main menu will be displayed (M_Main). It contains the following information:

- current date and time;
- evaporator inlet water temperature;
- evaporator outlet water temperature;
- unit status;

```
M_Main
+-----+
| 00 00  00 00 00 |
| Inlet  water  00.0°C |
| Outlet water  00.0°C |
| ON |
+-----+
```

To switch on the unit press the On/Off key.

3.5 General description of menus

General description of the menus featured in the application; all the masks are shown and described in the chapter 5

Main menu

The main menu is displayed when the unit is started up and consists of the masks described in the section Main Menu.

Maintenance menu

The maintenance menu can be accessed by pressing key 2. It shows the compressor and pump hour meters as well as the alarm history if a clock board has been installed.

If the maintenance password is entered (given to maintenance personnel on request) it will be possible to set the device hour meter alarm thresholds, clear the hour meter, set the probes, set the pump type and turnover time and enable the buzzer.

I/O Menu

The I/O menu can be accessed by pressing key 4 and shows the system's inputs and outputs.

Clock menu

The clock menu can be accessed by pressing key 5 and contains the time and date configuration.

Setpoint Menu

The Setpoint menu can be accessed by pressing key 6 and allows management of fixed and variable setpoints.

User menu

The User menu can be accessed by pressing key 7 and contains the configuration of user parameters. It is password protected.

Manufacturer menu

The Manufacturer menu can be accessed by pressing key 1 + key 7 together and contains the configuration of factory-set parameters. It is password protected.

Alarm menu

The Alarm menu can be accessed by pressing key 12 and gives information about the alarms that have been triggered.

4 Alarm management

The alarms are divided into three categories:

1. Warnings only (with display of warning message and buzzer or display of warning message, buzzer and alarm relay)
2. Circuit alarms (with deactivation of the circuit concerned, display of alarm message, buzzer and alarm relay);
3. Serious alarms (with shut down of the whole system, display of alarm message, buzzer and alarm relay).

Warnings

- Unit maintenance warning;
- Compressor maintenance warning;
- Clock board failure or disconnection;

Circuit alarms

- High pressure/pressure switch alarm: immediate shut down of the compressor and manual resetting
- Low pressure alarm with automatic/manual resetting (see description of its operation)
- Compressor thermal switch alarm with immediate shut down of the compressor and manual resetting;
- Fan thermal switch alarm, with fan stop and manual resetting.

Serious Alarms

- lack of water flow digital input alarm, delayed at start-up and at full capacity operation;
- evaporator antifreeze alarm, evaporator outlet probe function with activation setpoint and reset differential, with manual resetting
- serious alarm from digital input. Immediate shut down of the unit and manual resetting.
- freecooling valve anomaly.

The alarms are reset manually by pressing the alarm key twice.

4.1 Alarm table

Alarm description	Code	Mask	Troubleshooting
Antifreeze alarm	AL:002	M_Alarm5	Verify the correct working of the pumps and the water circulating
Evaporator 1 Freeze alarm	AL:008	M_Alarm6	Verify the correct working of the pumps and the water circulating
Evaporator 2 Freeze alarm	AL:009	M_Alarm7	Verify the correct working of the pumps and the water circulating
Circuit 1 compressors overload	AL:016-017	M_Alarm10-15	Verify the correct working of the compressors
Circuit 2 compressors overload	AL:018-019	M_Alarm20-25	Verify the correct working of the compressors
Evaporator flow alarm	AL:005	M_Alarm30	Verify the correct working of the pumps
High pressure circuit 1	AL:012	M_Alarm40	Verify the correct working of the fans
High pressure circuit 2	AL:013	M_Alarm45	Verify the correct working of the fans
Low pressure circuit 1	AL:010	M_Alarm60	Verify the correct refrigerant charge
Low pressure circuit 2	AL:011	M_Alarm65	Verify the correct refrigerant charge
High pressure alarm transducer 1	AL:023	M_Alarm70	Verify the correct working of the fans
High pressure alarm transducer 2	AL:024	M_Alarm75	Verify the correct working of the fans
Serious alarm by digital input	AL:001	M_Alarm80	Verify the cause of the external alarm
Condensing fans alarm	AL:049	M_Alarm100	Verify the correct working of the fans

Alarm description	Code	Mask	Troubleshooting
Evaporator pumps overload	AL:003	M_Alarm105	Verify the correct working of the pumps
B1 probe fault or not connected	AL:030	M_Alarm130	Verify the electrical wiring or replace the probe
B2 probe fault or not connected	AL:031	M_Alarm135	Verify the electrical wiring or replace the probe
B3 probe fault or not connected	AL:032	M_Alarm130	Verify the electrical wiring or replace the probe
B4 probe fault or not connected	AL:033	M_Alarm145	Verify the electrical wiring or replace the probe
B5 probe fault or not connected	AL:034	M_Alarm150	Verify the electrical wiring or replace the probe
B6 probe fault or not connected	AL:035	M_Alarm155	Verify the electrical wiring or replace the probe
B7 probe fault or not connected	AL:036	M_Alarm160	Verify the electrical wiring or replace the probe
B8 probe fault or not connected	AL:037	M_Alarm165	Verify the electrical wiring or replace the probe
Compressor 1 maintenance	AL:041	M_Alarm175	Verify the correct working of the compressor 1
Compressor 2 maintenance	AL:042	M_Alarm180	Verify the correct working of the compressor 2
Compressor 3 maintenance	AL:043	M_Alarm185	Verify the correct working of the compressor 3
Compressor 4 maintenance	AL:044	M_Alarm190	Verify the correct working of the compressor 4
32K clock board fault or not connected	AL:050	M_Alarm195	Verify the correct insert of the clock card
Phase sequence alarm	AL:007	M_Alarm195	reverse the phase sequence of 400V power supply
Pump 1 overload	AL:025	M_Alarm210	Verify the correct working of the pump 1
Pump 2 overload	AL:026	M_Alarm220	Verify the correct working of the pump 2
Pump 1 maintenance	AL:045	M_Alarm230	Verify the correct working of the pump 1
Pump 2 maintenance	AL:046	M_Alarm240	Verify the correct working of the pump 2
Freecooling anomaly	AL:047	M_Alarm250	Verify the correct working of the freecooling valve

4.2 Alarm history

The unit has an alarm history function. To activate this function it is necessary to install the optional clock board, provided with 32k memory, and enable its use from the mask (ref. mask *M_MANUF27* 5.1.7 see Manufacturer menu , page 27)

Alarms are memorised according to priorities decided at the programming stage. Each alarm has been attributed a priority code (the lower the code, the higher the priority); in this way if two alarms with different priorities are tripped at the same time, only the alarm with the lower code is stored (ref. 5.1.8 Alarm menu).

In addition to the alarm code, the function stores the date and time, evaporator inlet and outlet temperatures, setpoint and band used at the moment the alarm is activated (ref. mask *M_MAINT17* see page).

```

M_Maint17
+-----+
|History alarm  0000|
|AL000 00:00 00/00/00|
|Set  00.0 Band  00.0|
|T.In 00.0 T.Out 00.0|
+-----+

```

A maximum number of 1600 alarms can be stored. After this limit is reached memorisation will again start from the beginning, i.e. the oldest alarm will be overwritten with the new data.

5 Menu tree structure

5.1.1 Main menu

M_MainMask

```

+-----+
| 00 00  00 00  00 |
| Inlet  water  00.0°C |
| Outlet water  00.0°C |
| ON |
+-----+

```

The main information regarding the chiller's operation is displayed here. If the (optional) clock board has been installed, the current date and time will also be displayed

M_Main20

```

+-----+
| Water temperature: |
| Inlet              | 00.0°C |
| Outlet Ev.1       | 00.0°C |
| Outlet Ev.2       | 00.0°C |
+-----+

```

Here it is possible to read the temperature value

M_Main30

```

+-----+
| Status condensation: |
| Press. C1:          | 00.0 bar |
| Press. C2:          | 00.0 bar |
| Fan speed           | 000.0 % |
+-----+

```

Here it is possible to read the condensation status

M_Main40

```

+-----+
| Compressor status:  |
| Cp.1: OFF Cp.2:    |
| Cp.2: OFF Cp.4: OFF |
+-----+

```

Here it is possible to read the compressors status

M_Main50

```

+-----+
| Status pumps:       |
| Pump 1:            | OFF |
| Pump 2:            |    |
+-----+

```

Here it is possible to read the pump status

M_Main60

```

+-----+
| Status Freecooling 1 |
| T. external:        | 00.0°C |
| Free-cooling:       | OFF |
| Coil partializ.:    | OFF |
+-----+

```

Here it is possible to read the freecooling status
- external air temperature
- freecooling status
- coil partialization

M_Main70

```

+-----+
| Status Freecooling 2 |
| Valve status:CLOSED |
| V. IS CLOSING |
+-----+

```

- freecooling valve status OPEN or CLOSE
- the switching phase (V. IS CLOSING or V. IS OPENING)

M_Main70

```

+-----+
| Status Freecooling 2 |
| Valve status:CLOSED |
| Forced Valve |
| V. IS CLOSING |
+-----+

```

- Forced Valve indicates that the valve is in the maintenance phase.

5.1.2 Maintenance menu

M_Maint5

```

+-----+
| Pump 1 hour meters |
| Hours              | 000000 |
+-----+

```

```
M_Maint6
+-----+
| Pump 2 hour meters |
|                     |
| Hours              000000 |
+-----+
```

```
M_Maint10
+-----+
| Hour meters |
| Compressor 1 000000 |
| Compressor 2 000000 |
+-----+
```

```
M_Maint15
+-----+
| Hour meters |
| Compressor 2 000000 |
| Compressor 4 000000 |
+-----+
```

```
M_Maint17
+-----+
| History alarm 0000 |
| AL000 00:00 00/00/00 |
| Set 00.0 Band 00.0 |
| T.In 00.0 T.Out 00.0 |
+-----+
```

This is the alarm history mask.

```
M_Pw_Maint
+-----+
| MAINTENANCE MENU |
+-----+
| Insert maintenance |
| password           0000 |
+-----+
```

The maintenance password is required for viewing the following masks. The password is only available on request.

```
M_Maint20
+-----+
| Pump 1 hour meter |
| Threshold 000x1000 |
| Req.reset  N 000000 |
+-----+
```

In these masks it is possible to modify the value of the device maintenance alarm threshold and reset the hour meter of each device after it has undergone maintenance

```
M_Maint21
+-----+
| Pump 2 hour meter |
| Threshold 000x1000 |
| Req.reset  N 000000 |
+-----+
```

```
M_Maint25
+-----+
| Compressor 1 |
| hour meter |
| Threshold 000x1000 |
| Req.reset  N 000000 |
+-----+
```

```
M_Maint30
+-----+
| Compressor 2 |
| hour meter |
| Threshold 000x1000 |
| Req.reset  N 000000 |
+-----+
```

```
M_Maint35
+-----+
| Compressor 2 |
| hour meter |
| Threshold 000x1000 |
| Req.reset  N 000000 |
+-----+
```

```
M_Maint40
+-----+
| Compressor 4 |
| hour meter |
| Threshold 000x1000 |
| Req.reset  N 000000 |
+-----+
```

```
M_Maint45
+-----+
| Filters config. |
| Enable          | N |
| Dig. delay time | 0s|
+-----+
```

From this mask it is possible to enable the software filters applied on analog inputs. The detected input value is transmitted to the control if it maintains the value for a time equal to or greater than the time set.

```
M_Maint50
+-----+
| Inputs probes offset |
| B1: 0.0   B2: 0.0  |
| B3: 0.0   B4: 0.0  |
+-----+
```

Here it is possible to set probe offset values to be added to or subtracted from readings. (See 17 flap for installation of clock board (optional) .)

```
M_Maint51
+-----+
| Inputs probes offset |
| B5: 0.0   B6: 0.0  |
| B7: 0.0   B8: 0.0  |
+-----+
```

```
M_Maint58
+-----+
| Pump number:      | 0 |
+-----+
```

Here it is possible to set pumps number.

```
M_Maint60
+-----+
| Pumps rotation   |
| type:            |
|                 |
| MANUAL           |
+-----+
```

Here it is possible to set the rotation of the pump

```
M_Maint65
+-----+
| Pumps rotation   |
| time:            |
|                 |
| 000 hours        |
+-----+
```

```
m_maint70
+-----+
| Pumps sequence   |
| selection:        |
|                 |
| SEQUENCE 2       |
+-----+
```

```
m_maint72
+-----+
| Dry-cooler pump  |
| enable:          | N |
| Anticipation time: |
|                 | 000 s|
+-----+
```

```
M_Maint75
+-----+
| Erase historical |
| memory board    | N |
+-----+
```

This mask only appears if the clock board has been configured and the unit is off. Selecting S activates the procedure of erasing all the historical data. During this operation, a stand-by message will appear on the last line of the mask and no other operation will be possible until erasure is complete.

```
M_Maint80
+-----+
| Buzzer enable:   |
|                 | No |
+-----+
```

```
M_Maint100
+-----+
| Insert another   |
| maintenance     |
| password         |
|                 | 0000 |
+-----+
```

5.1.3 I/O Menu

This set of masks provides a complete display of the statuses of the analog and digital inputs and outputs connected to the microprocessor.

M_Pw_InOut

```
+-----+
| INPUT/OUTPUT MENU |
+-----+
| Insert maintenance |
| password           | 0000 |
+-----+
```

M_InOut05

```
+-----+
| INPUT/OUTPUT MENU |
+-----+
| Press DOWN key to |
| continue           |
+-----+
```

M_InOut10

```
+-----+
| Digital inputs     |
| CCCCCCCCCCCCCC   |
| Digital outputs    |
| OOOOOOOOOOOOOO   |
+-----+
```

M_InOut15

```
+-----+
| Analog inputs     |
| B1:              | 00.0 bar |
| B2:              | 00.0 bar |
+-----+
```

M_InOut20

```
+-----+
| Analog inputs     |
| B3:              | 00.0°C |
| B4:              | 00.0°C |
+-----+
```

M_InOut25

```
+-----+
| Analog inputs     |
| B5:              | 00.0°C |
| B6:              | 00.0°C |
+-----+
```

M_InOut30

```
+-----+
| Analog inputs     |
| B7:              | 00.0°C |
| B8:              | 00.0°C |
+-----+
```

M_InOut35

```
+-----+
| Analog output     |
| Y1:              | 00.0 V  |
| Y3:              | 000.0 % |
+-----+
```

5.1.4 Clock menu

M_Clock5

```

+-----+
|      |
|  Clock not |
| installed  |
|      |
+-----+
  
```

When the clock key is pressed, this mask will be displayed if the clock board has not been configured in the manufacturer branch (ref. mask *M_MANUF27*)

M_Clock10

```

+-----+
| Clock configuration |
+-----+
| Time      00:00    |
| Date     00/00/00 |
+-----+
  
```

When the clock key is pressed, if the clock board has been configured in the manufacturer branch (ref. mask *M_MANUF27*) this mask is displayed; from here it is possible to set the current date and time.

5.1.5 Setpoint Menu

M_Setpoint1

```

+-----+
| Actual setpoint    |
|                  |
|                  |
|                  |
|                  |
|                  |
|                00.0°C |
|                  |
+-----+
  
```

By pressing the SET key it is possible to access the following masks in order to view the summer and winter setpoints and active differentials

M_Pw_Set

```

+-----+
|      SETPOINT MENU      |
+-----+
| Insert user             |
| password      0000    |
+-----+
  
```

M_Setpoint5

```

+-----+
| Summer setpoint      |
|                   00.0°C |
| Winter setpoint     |
|                   00.0°C |
+-----+
  
```

M_Setpoint10

```

+-----+
| Second summer       |
| setpoint    00.0°C |
| Second winter     |
| setpoint    00.0°C |
+-----+
  
```

5.1.6 User menu

User menu access is password protected.

M_Pw_User

```

+-----+
|      USER MENU      |
+-----+
| Insert user             |
| password      0000    |
+-----+
  
```

M_User5

```

+-----+
| Summer temperature  |
| setpoint limits    |
| Low        00.0°C  |
| High       00.0°C  |
+-----+
  
```

In these masks it is possible to select the minimum and maximum summer and winter setpoint values that may be set.

M_User15

```

+-----+
| Winter temperature  |
| setpoint limits    |
| Low        00.0°C  |
| High       00.0°C  |
+-----+
  
```

M_User17

```

+-----+
| Regulat. tmperature |
|                       |
| Type      INLET      |
+-----+

```

M_User20

```

+-----+
| Inlet regulation     |
|                       |
| Type      PROPORTION. |
| Integration t. 0000s |
+-----+

```

If inlet regulation is selected, it is possible to choose whether to adopt a proportional or a proportional + integral type of regulation. In the latter case an integration time will also be set.

M_User22

```

+-----+
| Outlet regulation    |
|                       |
| Time on      0000s   |
| Time off    0000s   |
+-----+

```

M_User23

```

+-----+
| Outlet regulation   |
| force off          |
| Summer      00.0°C |
| Winter     00.0°C |
+-----+

```

M_User24

```

+-----+
| External setpoint   |
| Enable            N |
| Min.             00.0°C |
| Max.             00.0°C |
+-----+

```

M_User25

```

+-----+
| Temperature band   |
|                   00.0°C |
+-----+

```

This mask enables the temperature regulation band to be set; on the basis of this value, according to the type of regulation selected, the proportional band or neutral zone will be calculated.

M_User30

```

+-----+
| Time beetween     |
| main pump/fan    |
| and compressors  |
| start           000s |
+-----+

```

In this mask it is possible to set the minimum delay between the pump start and compressor start

M_User35

```

+-----+
| Delay on switching |
| the main          |
| pump/fan off      |
|                   000s |
+-----+

```

In this mask the pump shut off delay can be set.

M_User40

```

+-----+
| Digital input remote |
| on / off            N |
| Digital input remote |
| Summer / Winter    N |
+-----+

```

In this mask it is possible to set/enable the digital input remote on/off command. The summer/winter switching is not available.

M_User42

```

+-----+
| Supervisory remote  |
| on / off            N |
| Supervisory remote  |
| Summer / Winter    N |
+-----+

```

In this mask it is possible to set/enable the remote on/off command from the supervisory system. The summer/winter function is not available.

```
M_User45
-----
Parametri freecool.:
Delta          00.0°C
Diff.          00.0°C
-----
```

```
M_User50
-----
Defrost parameters
Start          00.0°C
Stop           00.0°C
-----
```

In this mask it is possible to set the defrost regulation parameters.

```
M_User55
-----
Defrost parameters
Delay time     00000s
Maximum time   00000s
Drip time      000s
-----
```

```
M_Language_U
-----
Language setting:
GERMAN
-----
```

```
M_User60
-----
Insert another
user password
0000
-----
```

Here it is possible to change the user access password.

5.1.7 Manufacturer menu

User menu access is password protected. The password is only available on request.

```
M_Pw_Manuf
-----
MANUFACTURER MENU
Insert manufacturer
password      0000
-----
```

```
M_Manuf5
-----
MANUFACTURER MENU
Press DOWN key to
continue
-----
```

```
M_Manuf6
-----
Heatpump enable:
N
-----
```

```
M_Manuf7
-----
Free-cooling enable:
N
-----
```

```
M_Manuf10
-----
Probes enable
B1: N B2: N B3: N
B4: N B5: N B6: N
B7: N B8: N
-----
```

```
M_Manuf15
-----
Pression probe conf.
Type: 4-20 mA probe
4mA          000.0bar
20mA         000.0bar
-----
```

```
M_Manuf20
-----
Compressors config.
Circuit Nr.   0
Comp. per circuit 0
-----
```

```
M_Manuf22
-----
Evaporator config:
N
-----
```

```
M_Manuf23
-----
Pump number: 0
-----
```

```
M_Manuf27
-----
Clock board 32k
Enable       N
-----
```

```
M_Manuf28
-----
Digital input 14
configuration
SERIOUS ALARM
-----
```

```
M_Manuf30
-----
Config. pump down
Enable       N
Max time     000s
-----
```

```
M_Manuf40
-----
Minimum compressors
power-on time 0000s
Minimum compressors
power-on time 0000s
-----
```

```
M_Manuf45
-----
Min time betw. diff.
comp. starts 0000s
Min time betw. same
comp. starts 0000s
-----
```

```
M_Manuf50
-----
Condensation
Enable : NO
Type   : INVERTER
-----
```

```
M_Manuf55
-----+
Condensation
Fans Nr.          0
Condensator: SINGLE
-----+-----
```

```
M_Manuf60
-----+
Condensation
Setpoint    000.0---
Diff.      000.0---
-----+-----
```

```
M_Manuf70
-----+
Inverter
Max. speed  00.0V
Min. speed  00.0V
Speed up time 000s
-----+-----
```

```
M_Manuf80
-----+
Prevent
Setpoint    00.0---
Diff.      00.0---
-----+-----
```

```
M_Manuf81
-----+
Prevent
Devices exit
delay      000 s
-----+-----
```

```
M_Manuf84
-----+
Transducers high
pressure alarm
enable      N
-----+-----
```

```
M_Manuf85
-----+
Transducers high
pressure alarm
Setpoint    00.0bar
Diff.      00.0bar
-----+-----
```

```
M_Manuf90
-----+
Low pressure alarm
Startup delay 000s
Run delay    000s
-----+-----
```

```
M_Manuf91
-----+
Low pressure alarm
Events Nr.   0
Period      0000s
Timeout start 000s
-----+-----
```

```
M_Manuf100
-----+
Antifreeze alarm
Setpoint    00.0°C
Diff.      00.0°C
-----+-----
```

```
M_Manuf105
-----+
Antifreeze heater
Setpoint    00.0°C
Diff.      00.0°C
-----+-----
```

```
M_Manuf110
-----+
Evaporat. flow alarm
Startup delay 000s
Run delay    000s
-----+-----
```

```
M_Manuf115
-----+
Condens. flow alarm
Startup delay 000s
Run delay    000s
-----+-----
```

```
M_Manuf116
-----+
Pump switch off
delay on flow alarm:
000 s
-----+-----
```

```
M_Manuf120
-----+
Config. freecooling
Valve type  0/10V
-----+-----
```

```
M_Manuf121
-----+
Freecooling config
fan speed:
Min at Set - 0.0 °C
Max at Set - 0.0 °C
-----+-----
```

```
M_Manuf122
-----+
FC differential
startup    0.0°C
-----+-----
```

```
M_Manuf123
-----+
Config. Freecooling:
HP prevent coil part
Set:      00.0 bar
Diff:    00.0 bar
-----+-----
```

```
M_Manuf124
-----+
Freecooling anomaly
alarm enabled:
N
-----+-----
```

```
M_Manuf125
-----+
Freecooling anomaly
Delay:    000 s
Reset:    AUT
Diff.:    0.0 °C
-----+-----
```

```
M_Manuf126
-----+
Freecooling anomaly
if:
FC=N |Tfc-Tin >0.0°C
FC=Y |Tfc-Tin|<0.0°C
-----+-----
```

```
M_Manuf127
-----+
Capacity limit in FC
Enable:      N
Delta T:    00.0°C
Diff.:      0.0°C
-----+-----
```

```
M_Manuf128
-----+
Freecooling valve
Running time: 000 s
Enable rotation: N
Period:    000 hours
-----+-----
```

```
M_Manuf129
-----+
Forced time:
000 s
Adjust:
0000 s
-----+-----
```

```
M_Manuf130
-----+
Reversing valve
logic heat pump unit
N.C.
-----+-----
```

```
M_Manuf131
-----+
Defrost config.
Probe TEMPERATURE
Type SIMULTANEOUS
Off Comp: NONE
-----+-----
```

```
M_Superv_01
-----+
Supervisory System
Communication speed:
1200 bps
Identificat.Nr.:000
-----+-----
```

```
M_Superv_02
-----+
Communication
protocol:
Carel
-----+-----
```

```
M_Ain_tast
-----+
ANALOG INPUT BY
KEYBOARD ENABLE:
N
-----+-----
```



```
M_Ain_tast_set
-----+
AIN by keyboard:
P1 :N Tout1:N
P2 :N Tout2:N
Tin:N Text :N Tfc:N
-----+-----
```

```
M_Language_C
-----+
Language setting:
GERMAN
-----+-----
```

```
M_Manuf135
-----+
Reset all parameters
to default values N
-----+-----
```

```
M_Manuf190
-----+
Insert another
manufacturer
password
0000
-----+-----
```

5.1.8 Alarm menu

Each mask gives information about a specific alarm situation. The activation of the masks is accompanied by the sounding of the buzzer and tripping of the general alarm signalling relay. By pressing the *ALARM* key once the user can access the first active mask and then scroll all alarms using the   keys. Pressing the *ALARM* a second time will clear the alarm message. Each mask shows the code used in the alarm history to identify the particular event (ref. 4.2 Alarm history page 20)

M_Alarm00 +-----+ No alarms detected +-----+	M_Alarm5 +-----+ AL:002 Freeze alarm +-----+	M_Alarm6 +-----+ AL:008 Evaporator 1 Freeze alarm +-----+
M_Alarm7 +-----+ AL:009 Evaporator 2 Freeze alarm +-----+	M_Alarm10 +-----+ AL:016 Circuit 1 compressors overload +-----+	M_Alarm15 +-----+ AL:017 Circuit 1 compressors overload +-----+
M_Alarm20 +-----+ AL:018 Circuit 2 compressors overload +-----+	M_Alarm25 +-----+ AL:019 Circuit 2 compressors overload +-----+	M_Alarm30 +-----+ AL:005 Evaporator flow alarm +-----+
M_Alarm40 +-----+ AL:012 High pressure circuit 1 +-----+	M_Alarm45 +-----+ AL:013 High pressure circuit 2 +-----+	M_Alarm60 +-----+ AL:010 Low pressure alarm circuit 1 +-----+
M_Alarm65 +-----+ AL:011 Low pressure alarm circuit 2 +-----+	M_Alarm70 +-----+ AL:023 High pressure alarm trasducer 1 +-----+	M_Alarm75 +-----+ AL:024 High pressure alarm trasducer 2 +-----+
M_Alarm80 +-----+ AL:001 Serious alarm by digital input +-----+	M_Alarm100 +-----+ AL:049 Condensator fans alarm +-----+	M_Alarm105 +-----+ AL:003 Evaporator pumps overload +-----+
M_Alarm130 +-----+ AL:030 B1 probe fault or not connected +-----+	M_Alarm135 +-----+ AL:031 B2 probe fault or not connected +-----+	M_Alarm140 +-----+ AL:032 B3 probe fault or not connected +-----+
M_Alarm145 +-----+ AL:033 B4 probe fault or not connected +-----+	M_Alarm150 +-----+ AL:034 B5 probe fault or not connected +-----+	M_Alarm155 +-----+ AL:035 B6 probe fault or not connected +-----+
M_Alarm160 +-----+ AL:036 B7 probe fault or not connected +-----+	M_Alarm165 +-----+ AL:037 B8 probe fault or not connected +-----+	M_Alarm175 +-----+ AL:041 Compressor 1 maintenance +-----+

M_Alarm180

```
+-----+
|AL:042
|  Compressor 2
|  maintenance
+-----+
```

M_Alarm185

```
+-----+
|AL:043
|
|  Compressor 3
|  maintenance
+-----+
```

M_Alarm190

```
+-----+
|AL:044
|  Compressor 4
|  maintenance
+-----+
```

M_Alarm195

```
+-----+
|AL:050
|  32K clock board
|  fault or not
|  connected
+-----+
```

M_Alarm200

```
+-----+
|AL:07
|  PHASE SEQUENCE
|  ALARM
+-----+
```

M_Alarm210

```
+-----+
|AL:25
|  Pump 1
|  overload
+-----+
```

M_Alarm220

```
+-----+
|AL:26
|  Pump 2
|  overload
+-----+
```

m_alarm230

```
+-----+
|AL:45
|  Pump 1
|  maintenance
+-----+
```

m_alarm240

```
+-----+
|AL:46
|  Pump 2
|  maintenance
+-----+
```

m_alarm250

```
+-----+
|AL:47
|  Freecooling anomaly
+-----+
```

6 Application setting parameters

6.1 Maintenance menu

Parameter description	Mask	U.M.	Default
Pump 1 maintenance alarm threshold	M_Maint20	-	10x1000
Pump 2 maintenance alarm threshold	M_Maint21	-	10x1000
Compressor 1 maintenance alarm threshold	M_Maint25	-	10x1000
Compressor 2 maintenance alarm threshold	M_Maint30	-	10x1000
Compressor 3 maintenance alarm threshold	M_Maint35	-	10x1000
Compressor 4 maintenance alarm threshold	M_Maint40	-	10x1000
Filters action enable	M_Maint45	-	N
Filter delay	M_Maint45	s	2
Inputs probe B1 offset	M_Maint50	°C/bar	0.0
Inputs probe B2 offset	M_Maint50	°C/bar	0.0
Inputs probe B3 offset	M_Maint50	°C/bar	0.0
Inputs probe B4 offset	M_Maint50	°C/bar	0.0
Inputs probe B5 offset	M_Maint51	°C/bar	0.0
Inputs probe B6 offset	M_Maint51	°C/bar	0.0
Inputs probe B7 offset	M_Maint51	°C/bar	0.0
Inputs probe B8 offset	M_Maint51	°C/bar	0.0
Pump number	M_Maint58	-	0
Pumps rotation type	M_Maint60	-	AUTOMATIC
Pumps rotation time	M_Maint65	ore	6
Pumps sequence selection	M_Maint70	-	SEQUENCE 1
Dry-cooler pump enable	M_Maint72	-	N
Anticipation time	M_Maint72	s	30
Buzzer enable	M_Maint80	-	Y

6.2 Setpoint menu

Parameter description	Mask	U.M.	Default
Summer setpoint	M_Setpoint_5	°C	12.0
Winter setpoint	M_Setpoint_5	°C	40.0
Second summer setpoint	M_Setpoint_10	°C	12.0
Second winter setpoint	M_Setpoint_10	°C	40.0

6.3 User menu

Parameter description	Mask	U.M.	Default
Low summer temperature setpoint limits	M_User_5	°C	7.0
High summer temperature setpoint limits	M_User_5	°C	17.0
Low winter temperature setpoint limits	M_User_15	°C	40.0
High winter temperature setpoint limits	M_User_15	°C	50.0
Inlet regulation type	M_User_20	-	PROPORT.
Integration time	M_User_20	s	600
External setpoint enable	M_User24	-	N
External setpoint min value	M_User24	°C	0.0

External setpoint max value	M_User24	°C	50.0
Temperature band	M_User25	°C	4.0
Time between main pump/fan and compressors	M_User30	s	5
Delay on switching the main pump/fan off	M_User35	s	5
Digital input remote on / off enable	M_User40	-	N
Digital input remote summer / winter enable	M_User40	-	N
Supervisory remote on / off enable	M_User42	-	N
Supervisory remote summer / winter enable	M_User42	-	N
Freecooling delta	M_User45	°C	3.0
Freecooling differential	M_User45	°C	2.0
Defrost start pressure	M_User50	bar	2.0
Defrost stop pressure	M_User50	bar	12.0
Defrost delay	M_User55	s	1800
Defrost maximum time	M_User55	s	300
Defrost drip time	M_User55	s	10

6.4 Manufacturer menu

Parameter description	Mask	U.M.	Default
Heat pump enable	M_Manuf6	-	N
Free-cooling enable	M_Manuf7	-	N
Probes enable B1	M_Manuf10	-	S
Probes enable B2	M_Manuf10	-	S
Probes enable B3	M_Manuf10	-	N
Probes enable B4	M_Manuf10	-	S
Probes enable B5	M_Manuf10	-	S
Probes enable B6	M_Manuf10	-	N
Probes enable B7	M_Manuf10	-	N
Probes enable B8	M_Manuf10	-	N
Pressure probe type	M_Manuf15	-	4-20 mA
Value at 4mA / 0 V	M_Manuf15	bar	0.0
Value at 20mA / 5 V	M_Manuf15	bar	30.0
Circuit Number	M_Manuf20	-	2
Compressor number per circuit	M_Manuf20	-	2
Evaporator configuration	M_Manuf22	-	ONLY
Pump number	M_Manuf23	-	0
Clock board 32k enable	M_Manuf27	-	N
Digital input 14 configuration	M_Manuf28	-	SERIOUS ALARM
Minimum compressors power-on time	M_Manuf40	s	60
Minimum compressors power-on time	M_Manuf40	s	360
Min time between different compressor starts	M_Manuf45	s	10
Min time between same compressor starts	M_Manuf45	s	450
Condensation control enable	M_Manuf50	-	PRESSURE
Condensation control type	M_Manuf50	-	INVERTER
Fans Number	M_Manuf55	-	1
Condensing type	M_Manuf55	-	ONLY
Condensing Setpoint value	M_Manuf60	bar	11.0
Condensing differential value	M_Manuf60	bar	10.0
Max. speed of fan	M_Manuf70	V	10
Min. speed of fan	M_Manuf70	V	0
Speed up time	M_Manuf70	s	0
High pressure prevent enable	M_Manuf80	-	S
High pressure prevent Setpoint	M_Manuf80	bar	26.5
High pressure prevent differential	M_Manuf80	bar	2.0

High pressure prevent delay	M_Manuf81	s	10
Transducers high pressure alarm enable	M_Manuf84	-	N
Transducers high pressure alarm Setpoint	M_Manuf85	bar	27.0
Transducers high pressure alarm differential	M_Manuf85	bar	2.0
Low pressure alarm at start-up delay	M_Manuf90	s	120
Low pressure alarm running delay	M_Manuf90	s	0
Low pressure alarm events number	M_Manuf91	-	3
Low pressure alarm period	M_Manuf91	s	3600
Low pressure alarm timeout start	M_Manuf91	s	20
Antifreeze alarm setpoint	M_Manuf100	°C	4.0
Antifreeze alarm differential	M_Manuf100	°C	1.0
Antifreeze heater setpoint	M_Manuf105	°C	5.0
Antifreeze heater differential	M_Manuf105	°C	1.0
Evaporator. flow alarm start-up delay	M_Manuf110	s	20
Evaporator. flow alarm running delay	M_Manuf110	s	10
Pump switch off delay on flow alarm	M_Manuf116	s	120
Freecooling min. fan speed	M_Manuf121	°C	SETPOINT-5.0
Freecooling max. fan speed	M_Manuf121	°C	SETPOINT-3.0
FC differential start up	M_Manuf122	°C	1.0
HP prevent with coil partialization setpoint	M_Manuf123	bar	23.0
HP prevent with coil partialization differential	M_Manuf123	bar	5.0
Freecooling anomaly alarm enable	M_Manuf124	-	S
Freecooling anomaly delay	M_Manuf125	s	300
Freecooling anomaly reset	M_Manuf125	-	AUT
Freecooling anomaly differential	M_Manuf125	°C	0.2
Freecooling anomaly with FC OFF	M_Manuf126	°C	Tfc-Tin > 1
Freecooling anomaly with FC ON	M_Manuf126	°C	 Tfc-Tin < 0.5
Capacity limit in FC enable	M_Manuf127	-	S
Capacity limit in FC delta T	M_Manuf127	°C	5.0
Capacity limit in FC differential	M_Manuf127	°C	1.0
Freecooling valve running time	M_Manuf128	s	180
Freecooling valve enable rotation	M_Manuf128	-	S
Freecooling valve rotation period	M_Manuf128	hours	168
Forced time	M_Manuf129	s	50
Counter adjust	M_Manuf129	s	3600
Reversing valve logic heat pump unit	M_Manuf130	-	N.O.
Defrost probe type	M_Manuf131	-	PRESSURE
Defrost type	M_Manuf131	-	CONTEMPORANEO US
Switch off compressor on defrost	M_Manuf131	-	NO
Supervisory system communication speed	M_Superv_01	bps	19200
Supervisory system identification number	M_Superv_01	-	1
Communication protocol	M_Superv_02	-	CAREL
Analog input by keyboard enable	M_Ain_tast	-	N

7 Architecture of the control system

7.1 Microprocessor layout

Connector description

1. connector to the power supply [G(+), G0(-)];
2. fuse 250 Vac, 2A delayed (T2 A);
3. universal analog inputs NTC, 0/1 V, 0/5 V, 0/20 mA, 4/20 mA;
4. passive analog inputs NTC and ON/OFF
5. passive analog inputs NTC
6. Yellow LED indicating power supply on and 3 indicator LEDs;
7. 0/10 V analogue outputs and PWM phase-cut outputs;
8. digital inputs at 24 Vac/Vdc;
9. digital inputs at 230 Vac or 24 Vac/Vdc;
10. connector with Vref for 5V power supply to probes and V Term for power supply to terminal;
11. connector for all standard terminals in the pCO series and for downloading the application program;
12. pLAN local network connector;
13. connector for connection to the programming key;
14. digital outputs to relay;
15. flap for selection of analog input type;
16. flap for installation of serial board:
 - RS485 for supervisor (optional)
 - Gateway (protocol converter, optional)
17. flap for installation of clock board (optional) .

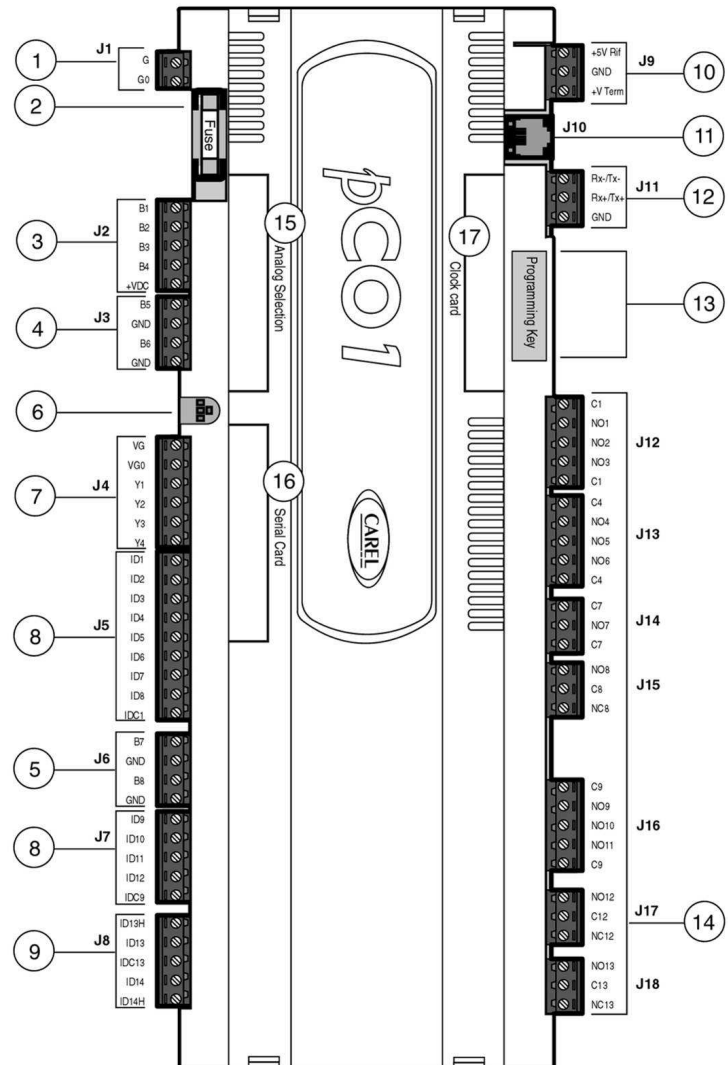

Figure 15: Layout microprocessore

7.2 Description of inputs and outputs

7.2.1 Chiller only cooling model

Conn.	Name	Signal	Description		
			4 Compressors - 2 Circ.	2 Compressors – 2 Circ.	1 Compressor – 1 Circ.
Analog input					
J2-1	B1	4..20 mA	Condensation pressure circ.1	Condensation pressure circ.1	Condensation pressure circ.1
J2-2	B2	4..20 mA	Condensation pressure circ.2	Condensation pressure circ.2	
J2-3	B3	4..20 mA	Remote adjustment of setpoint	Remote adjustment of setpoint	Remote adjustment of setpoint
J3-3	B4	NTC	Inlet water temperature	Inlet water temperature	Inlet water temperature
J3-1	B5	NTC	Outlet water temperature 1	Outlet water temperature 1	Outlet water temperature 1
J3-3	B6	NTC	Outlet water temperature 2	Outlet water temperature 2	
J6-1	B7	NTC			
J6-3	B8	NTC			
Analog output					
J4-3	Y1	0..10 V	Condensation fan control	Condensation fan control	Condensation fan control
Digital input					
J5-1	ID1	24 Vac/Vdc	High pressure switch - circuit 1	High pressure switch - circuit 1	High pressure switch - circuit 1
J5-2	ID2	24 Vac/Vdc	High pressure switch - circuit 2	High pressure switch - circuit 2	
J5-3	ID3	24 Vac/Vdc	Low pressure switch - circuit 1	Low pressure switch - circuit 1	Low pressure switch - circuit 1
J5-4	ID4	24 Vac/Vdc	Low pressure switch - circuit 2	Low pressure switch - circuit 2	
J5-5	ID5	24 Vac/Vdc	Thermal switch compressors 1 and 2	Thermal switch compressors 1 and 2	Thermal switch compressors 1 and 2
J5-6	ID6	24 Vac/Vdc	Thermal switch compressors 3 and 4	Thermal switch compressors 3 and 4	
J5-7	ID7	24 Vac/Vdc	Thermal switch-Pump 1	Thermal switch-Pump 1	Thermal switch-Pump 1
J5-8	ID8	24 Vac/Vdc	Thermal switch-Pump 2	Thermal switch-Pump 2	Thermal switch-Pump 2
J7-1	ID9	24 Vac/Vdc	Water flow switch	Water flow switch	Water flow switch
J7-2	ID10	24 Vac/Vdc	General fan alarm	General fan alarm	General fan alarm
J7-3	ID11	24 Vac/Vdc	Phase direction alarm	Phase direction alarm	Phase direction alarm
J7-4	ID12	24 Vac/Vdc	Remote On/Off	Remote On/Off	Remote On/Off
J8-2	ID13	24 Vac/Vdc			
J8-4	ID14	24 Vac/Vdc	Serious alarm/secondary setpoint	Serious alarm/secondary setpoint	Serious alarm/secondary setpoint
Digital output					
J12-2	NO1	relè NO	ON/OFF compr. 1 (Circ. 1)	ON/OFF compr. 1 (Circ. 1)	ON/OFF compr. 1 (Circ. 1)
J12-3	NO2	relè NO	ON/OFF compr. 2 (Circ. 1)		
J12-4	NO3	relè NO	ON/OFF compr. 3 (Circ. 2)	ON/OFF compr. 2 (Circ. 2)	
J13-2	NO4	relè NO	ON/OFF compr. 4 (Circ. 2)		
J13-3	NO5	relè NO	ON/OFF pump 1	ON/OFF pump 1	ON/OFF pump 1
J13-4	NO6	relè NO	ON/OFF pump 2	ON/OFF pump 2	ON/OFF pump 2
J14-2	NO7	relè NO	ON/OFF antifreeze heaters	ON/OFF antifreeze heaters	ON/OFF resistenze antigelo
J15-1	NO8	relè NO	Remote general alarm (on relay for remote control and indicator light)	Remote general alarm (on relay for remote control and indicator light)	Remote general alarm (on relay for remote control and indicator light)
J16-2	NO9	relè NO	ON/OFF condenser fans	ON/OFF condenser fans	ON/OFF condenser fans
J16-3	NO10	relè NO			
J16-4	NO11	relè NO			
J17-1	NO12	relè NO	ON/OFF condenser fans 2	ON/OFF condenser fans 2	
J18-1	NO13	relè NO	On/Off unit	On/Off unit	On/Off unit

7.2.2 Heat pump chiller

Conn.	Name	Signal	Description		
			4 Compressors - 2 Circ.	2 Compressors – 2 Circ.	1 Compressor – 1 Circ.
Analog input					
J2-1	B1	4..20 mA	Condensation pressure circ.1	Condensation pressure circ.1	Condensation pressure circ.1
J2-2	B2	4..20 mA	Condensation pressure circ.2	Condensation pressure circ.2	
J2-3	B3	4..20 mA	Remote adjustment of setpoint	Remote adjustment of setpoint	Remote adjustment of setpoint
J3-1	B4	NTC	Inlet water temperature	Inlet water temperature	Inlet water temperature
J3-1	B5	NTC	Outlet water temperature 1	Outlet water temperature 1	Outlet water temperature 1
J3-3	B6	NTC	Outlet water temperature 2	Outlet water temperature 2	
J6-1	B7	NTC			
J6-3	B8	NTC			
Analog output					
J4-3	Y1	0..10 V	Condensation fan control	Condensation fan control	Condensation fan control
Digital input					
J5-1	ID1	24 Vac/Vdc	High pressure switch - circuit 1	High pressure switch - circuit 1	High pressure switch - circuit 1
J5-2	ID2	24 Vac/Vdc	High pressure switch - circuit 2	High pressure switch - circuit 2	
J5-3	ID3	24 Vac/Vdc	Low pressure switch - circuit 1	Low pressure switch - circuit 1	Low pressure switch - circuit 1
J5-4	ID4	24 Vac/Vdc	Low pressure switch - circuit 2	Low pressure switch - circuit 2	
J5-5	ID5	24 Vac/Vdc	Thermal switch compressors 1 and 2	Thermal switch compressors 1 and 2	Thermal switch compressors 1 and 2
J5-6	ID6	24 Vac/Vdc	Thermal switch compressors 3 and 4	Thermal switch compressors 3 and 4	
J5-7	ID7	24 Vac/Vdc	Thermal switch-Pump 1	Thermal switch-Pump 1	Thermal switch-Pump 1
J5-8	ID8	24 Vac/Vdc	Thermal switch-Pump 2	Thermal switch-Pump 2	Thermal switch-Pump 2
J7-1	ID9	24 Vac/Vdc	Water flow switch	Water flow switch	Water flow switch
J7-2	ID10	24 Vac/Vdc	General fan alarm	General fan alarm	General fan alarm
J7-3	ID11	24 Vac/Vdc	Phase direction alarm	Phase direction alarm	Phase direction alarm
J7-4	ID12	24 Vac/Vdc	Remote On/Off	Remote On/Off	Remote On/Off
J8-2	ID13	24 Vac/Vdc	Summer/Winter (HWA-H)	Summer/Winter (HWA-H)	Summer/Winter (HWA-H)
J8-4	ID14	24 Vac/Vdc	Serious alarm/secondary setpoint	Serious alarm/secondary setpoint	Serious alarm/secondary setpoint
Digital output					
J12-2	NO1	relè NO	ON/OFF compr. 1 (Circ. 1)	ON/OFF compr. 1 (Circ. 1)	ON/OFF compr. 1 (Circ. 1)
J12-3	NO2	relè NO	ON/OFF compr. 2 (Circ. 1)		
J12-4	NO3	relè NO	ON/OFF compr. 3 (Circ. 2)	ON/OFF compr. 2 (Circ. 2)	
J13-2	NO4	relè NO	ON/OFF compr. 4 (Circ. 2)		
J13-3	NO5	relè NO	ON/OFF pump 1	ON/OFF pump 1	ON/OFF pump 1
J13-4	NO6	relè NO	ON/OFF pump 2	ON/OFF pump 2	ON/OFF pump 2
J14-2	NO7	relè NO	ON/OFF antifreeze heaters	ON/OFF antifreeze heaters	ON/OFF resistenze antigelo
J15-1	NO8	relè NO	Remote general alarm (on relay for remote control and indicator light)	Remote general alarm (on relay for remote control and indicator light)	Remote general alarm (on relay for remote control and indicator light)
J16-2	NO9	relè NO	ON/OFF condenser fans	ON/OFF condenser fans	ON/OFF condenser fans
J16-3	NO10	relè NO	4-way valve position -circuit 1	4-way valve position -circuit 1	4-way valve position -circuit 1
J16-4	NO11	relè NO	4-way valve position -circuit 2	4-way valve position -circuit 2	
J17-1	NO12	relè NO	ON/OFF condenser fans 2	ON/OFF condenser fans 2	
J18-1	NO13	relè NO	On/Off unit	On/Off unit	On/Off unit

7.2.3 Freecooling chiller

Conn.	Name	Signal	Description		
			4 Compressors - 2 Circ.	2 Compressors – 2 Circ.	1 Compressor – 1 Circ.
Analog input					
J2-1	B1	4..20 mA	Condensation pressure circ.1	Condensation pressure circ.1	Condensation pressure circ.1
J2-2	B2	4..20 mA	Condensation pressure circ.2	Condensation pressure circ.2	
J2-3	B3	4..20 mA	Remote adjustment of setpoint	Remote adjustment of setpoint	Remote adjustment of setpoint
J3-1	B4	NTC	Inlet water temperature	Inlet water temperature	Inlet water temperature
J3-1	B5	NTC	Outlet water temperature 1	Outlet water temperature 1	Outlet water temperature 1
J3-3	B6	NTC	Outlet water temperature 2	Outlet water temperature 2	
J6-1	B7	NTC	External air temperature	External air temperature	External air temperature
J6-3	B8	NTC	Free-cooling temperature	Free-cooling temperature	Free-cooling temperature
Analog output					
J4-3	Y1	0..10 V	Condensation fan control	Condensation fan control	Condensation fan control
Digital input					
J5-1	ID1	24 Vac/Vdc	High pressure switch - circuit 1	High pressure switch - circuit 1	High pressure switch - circuit 1
J5-2	ID2	24 Vac/Vdc	High pressure switch - circuit 2	High pressure switch - circuit 2	
J5-3	ID3	24 Vac/Vdc	Low pressure switch - circuit 1	Low pressure switch - circuit 1	Low pressure switch - circuit 1
J5-4	ID4	24 Vac/Vdc	Low pressure switch - circuit 2	Low pressure switch - circuit 2	
J5-5	ID5	24 Vac/Vdc	Thermal switch compressors 1 and 2	Thermal switch compressors 1 and 2	Thermal switch compressors 1 and 2
J5-6	ID6	24 Vac/Vdc	Thermal switch compressors 3 and 4	Thermal switch compressors 3 and 4	
J5-7	ID7	24 Vac/Vdc	Thermal switch-Pump 1	Thermal switch-Pump 1	Thermal switch-Pump 1
J5-8	ID8	24 Vac/Vdc	Thermal switch-Pump 2	Thermal switch-Pump 2	Thermal switch-Pump 2
J7-1	ID9	24 Vac/Vdc	Water flow switch	Water flow switch	Water flow switch
J7-2	ID10	24 Vac/Vdc	General fan alarm	General fan alarm	General fan alarm
J7-3	ID11	24 Vac/Vdc	Phase direction alarm	Phase direction alarm	Phase direction alarm
J7-4	ID12	24 Vac/Vdc	Remote On/Off	Remote On/Off	Remote On/Off
J8-2	ID13	24 Vac/Vdc			
J8-4	ID14	24 Vac/Vdc	Serious alarm/secondary setpoint	Serious alarm/secondary setpoint	Serious alarm/secondary setpoint
Digital output					
J12-2	NO1	relè NO	ON/OFF compr. 1 (Circ. 1)	ON/OFF compr. 1 (Circ. 1)	ON/OFF compr. 1 (Circ. 1)
J12-3	NO2	relè NO	ON/OFF compr. 2 (Circ. 1)		
J12-4	NO3	relè NO	ON/OFF compr. 3 (Circ. 2)	ON/OFF compr. 2 (Circ. 2)	
J13-2	NO4	relè NO	ON/OFF compr. 4 (Circ. 2)		
J13-3	NO5	relè NO	ON/OFF pump 1	ON/OFF pump 1	ON/OFF pump 1
J13-4	NO6	relè NO	ON/OFF pump 2	ON/OFF pump 2	ON/OFF pump 2
J14-2	NO7	relè NO	ON/OFF antifreeze heaters	ON/OFF antifreeze heaters	ON/OFF resistenze antigelo
J15-1	NO8	relè NO	Remote general alarm (on relay for remote control and indicator light)	Remote general alarm (on relay for remote control and indicator light)	Remote general alarm (on relay for remote control and indicator light)
J16-2	NO9	relè NO	ON/OFF condenser fans	ON/OFF condenser fans	ON/OFF condenser fans
J16-3	NO10	relè NO	Open FC valve	Open FC valve	Open FC valve
J16-4	NO11	relè NO	Close FC valve	Close FC valve	Close FC valve
J17-1	NO12	relè NO	ON/OFF solenoid Circ. 1 and 2 for exchanger part.	ON/OFF solenoid Circ. 1 and 2 for exchanger part.	ON/OFF solenoid Circ. 1 and 2 for exchanger part.
J18-1	NO13	relè NO	On/Off unit	On/Off unit	On/Off unit

7.3 Optional boards

7.3.1 RS485 serial board for supervisory function

For the serial connection to a local or remote supervision system it is necessary to install an RS485 serial board, available on request (see Figure 16: RS485).

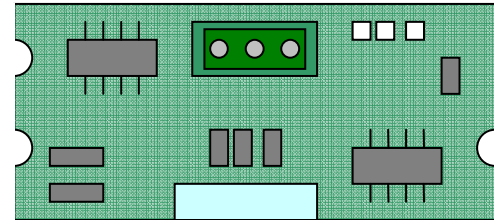

Figure 16: RS485 Serial Board

Connection to the local supervisor computer

The connection to the local supervisor computer is made via a RS485 serial line and communication takes place via the proprietary Carel protocol. A RS485/RS232 converter is needed for connecting to the serial port of the PC.

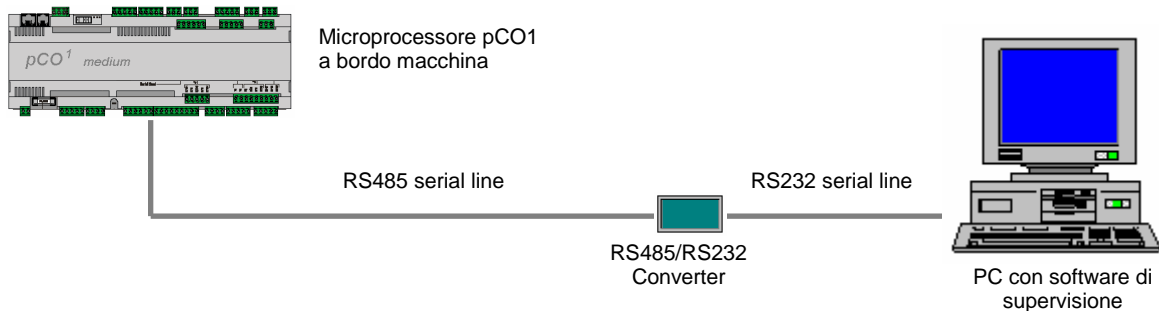

Figure 17: Connessione tra microprocessore e computer locale di supervisione

7.3.2 Clock board

The serial connection to a local or remote supervision system requires the installation of an RS485 serial board, available on request (see Figure 18: Clock Card).

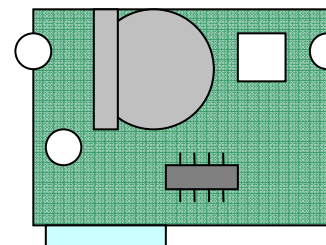

Figure 18: Clock Card

7.4 Technical data

General specifications

operating conditions	-10T60 °C 90% R H not condensing
protection rating	IP20, IP40 on front panel only
heat and fire resistance class	class D (UL94 - V0)
Immunity against over voltages	Class 1
number of manoeuvring cycles of automatic operations (e.g.: relay)	100 000
Class and structure of software	Class A

Electrical specifications

power supply (controller with connected terminal)	22 to 38 Vdc and 24 Vac \pm 15% 50/60 Hz. Maximum power consumption: 13 W
terminal block	with extractable male/female connectors maximum voltage: 250 Vac; cable size (2mm): min 0.5 to max 2,5
CPU	H8S2322 16 bits 14 MHz
program memory (on FLASH MEMORY)	16 bit organisation: 1 MByte (expandable to 2 MByte)
data memory (static RAM)	8 bit organisation: 128 kByte (expandable to 512 MByte)
Serial Board	16 bits organisation 4 kByte (upper limit: 400,000 recordings per memory location)
useful pCO1 cycle with applications of medium complexity	0.5 s

Analog inputs

number	8
Analog conversion	A/D converter 10 bit CPU built-in
type	<i>Passive</i> : NTC (inputs B5, B6, B7, B8) or clean contact digital input (5mA), selectable via dip-switch (B5-B6) <i>Universal</i> : NTC (see passive type), voltage 0 to 1 Vdc or 0 to 5 Vdc, current 0 to 20 mA or 4 to 20 mA, selectable via dip-switch (B1, B2, B3, B4)

Digital inputs

number	14
type	- optoisolated inputs at 24 Vac 50/60 Hz or 24 Vdc (ID1 to ID12) - optoisolated inputs at 24 Vac 50/60 Hz or 230 Vac (ID13 to ID14)

Analog outputs

number	4
type	- optoisolated 0 to 10 Vdc outputs (Y1 and Y2) - optoisolated PWM outputs phase-cut with 5 V pulse (Y3 and Y4)
power supply	external power supply 24 Vac/Vdc
output resolution	8 bit
maximum load	1k Ω (10 mA) at 0 to 10V and 470 Ω (10 mA) at PWM

Digital outputs

number	13
Type	-with electromechanical relays

