



User manual **CLIMATIC™ 50 - CHILLERS**



- Providing indoor climate comfort



Climatic 50

CHILLER & HEAT PUMP

INCLUDING NEOSYS RANGE

USER MANUAL

Ref: CL50-CHILLER-IOM_CUST-0808-E

CUSTOMER VERSION

LENNOX have been providing environmental solutions since 1895, our range of rooftop and chiller continues to meet the standards that have made LENNOX a household name. Flexible design solutions to meet YOUR needs and uncompromising attention to detail. Engineered to last, simple to maintain and Quality that becomes a standard. Further Information on www.lennox europe.com.

All the technical and technological information contained in this manual, including any drawing and technical descriptions provided by us, remain the property of Lennox and must not be used (except in operation of this product), reproduced, issued to or made available to third parts without the prior written agreement of Lennox.

The technical informations and specifications contained in this manual are for reference only. The manufacturer reserves the right to modify these without warning and without obligation to modify equipment already sold.

	Page
Introduction.....	3
Wiring connections.....	4
Configuration.....	8
Scheduling – Clock setting.....	9
Customized input/output.....	11
Standard input/output.....	14
Configuration of the BM50 plan address.....	15
Allocation of displays to the BM50.....	16
DC50 comfort display.....	17
DS50 menu tree.....	24
Error codes alarms.....	34

CLIMATIC™50

The new generation of microprocessor based control, **CLIMATIC™50** may be fitted to the Lennox Chiller or Heat pump range. It inherits 20 years of technology and field operating experience from its predecessors the CLIMATIC™1 and CLIMATIC™2.

LENNOX has found the latest hardware technology available on the market place and developed software specifically designed for Chiller and Heat pump applications, maximising the LENNOX unit's efficiency and performance.

Compatibility

This documentation is compatible with the programs Chiller and Heat pump:

- **NEOSYS range from software version NA050.01.**

Warning

Any parameter modification should be carried out by trained and licensed competent technician.

Before start-up or restart of a unit controlled by Climatic 50, it is mandatory to check adequacy between Climatic™50 and the unit with its options.

- **Menus (38xx) for unit and options,**
- **Menus (39xx) for communication.**

In case of wrong parameters, I/O links could be incorrect and may create some operation problems for the units and ultimately breakdowns.

Lennox cannot be held responsible for any claims on the units due to a wrong parameters sequence or a parameters modification carried out by non competent technicians. In this case, the warranty will be legally null and void.

IMPORTANT WARNING

Any wiring modification on the CLIMATIC™ 50 must be done by Lennox technician or employees having valid electrical qualification and authorisation.

For any modification of wiring on the 24V supply or on 4-20mA sensor, check the polarity prior to apply the power. Wrong polarity may cause serious damage and destroy the pLAN network. Lennox will not accept liability for damage caused by wrong power connection or any wiring modification done by people without valid training and qualifications.

Any external connection with the unit, using 24Vac voltage should not exceed a length of more than 30m. It concerns external contacts connected to Climatic™ 50 on logical inputs. Over 30 m, the installer must interface this information with relays or converters.

In any case, the 24Vac control voltage must not be used to drive external function with Climatic™ 50 logical output.

WARNING: Separate as much as possible probes, displays, logical input cables from power cables with strong inductive load, in order to avoid possible electromagnetic perturbations.

CONNECTION

SENSORS AND PROBES

- External sensors or probes connection must be carried out with the following cable:
 - Cable length up to 20m: AWG22 (0.34 mm²), 1 pair crossed with screen.
 - Cable length up to 50m: LiYCY-P (0.34 mm²), 1 pair with general shield.
- The cable length should not exceed 50m.
- For a better electromagnetic protection, Lennox recommends the use of LiYCY-P cable.

DISPLAY DS50

- The Display DS50 can be connected to the Climatic™ 50 either on one of the RJ12 connectors located on the board DT50, or directly on the main board BM50 connector J10.
- Connection is carried out by the flat 1.5m cable delivered with this DS50.
- In any the case, Display DS50 cannot be remotely connected.
- In case of Master/Slave installation, one, and only one, display DS50 must be connected on the pLan bus.

DISPLAY DC50 (Remote CONNECTION)

Warning: A wrong wiring of the display immediately damage it and/or the main board BM50.

- The optional DC50 is designed to be mounted on the wall.
- Fit the cable from the DT50 board through the back piece
- Fasten the back piece to the wall using the rounded head screws supplied in the packaging
- Connect the cable from the main board on the connector on the back of the DC50 display
- Fasten the front panel on the back piece using the flush head screws supplied
- Finally fit the click-on frame

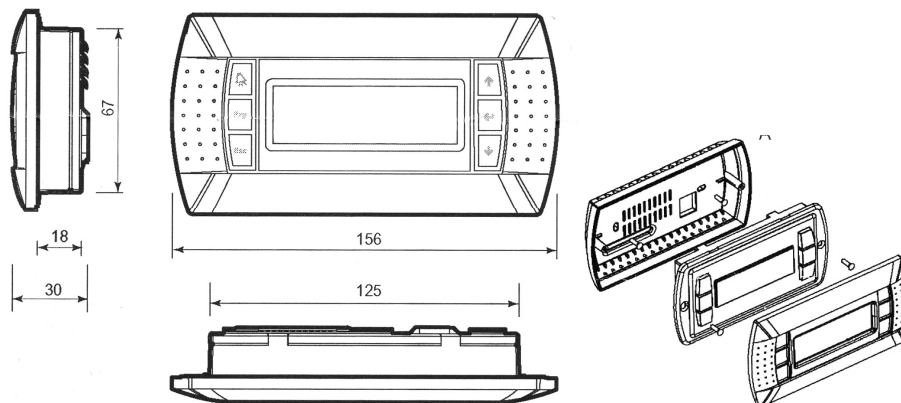

Display DC50 is connected to the Climatic™50 with the DT50 screw connector. Connection must be carried out by the following cable:

- Cable length up to 300m: AWG22 (0.34 mm²), 2 pairs crossed with screen.
- Cable length up to 500m: LiYCY-P (0.34 mm²), 2 pairs with general shield.
- The cable length should not exceed 500m.
- For a better electromagnetic protection, Lennox recommends the use of LiYCY-P cable.

CONNECTION ON DT50 DERIVATOR

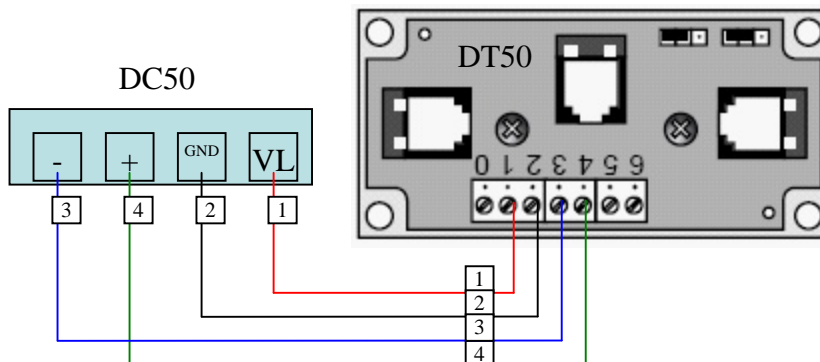

Terminal connection board installation guide DT 50

The board is fitted with three "telephone" RJ12 plugs. Ensure the board is correctly connected. Standard connection is:

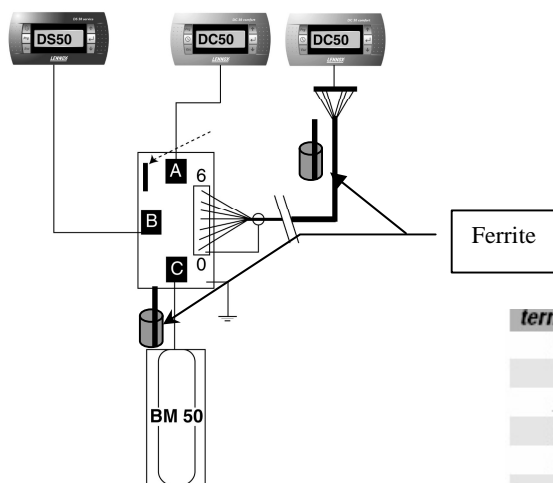

terminal	wire function	connections
0	earth	shield
1	+VRL (~30Vdc)	1st pair A
2	GND	2nd pair A
3	Rx/Tx-	3rd pair A
4	Rx/Tx+	3rd pair B
5	GND	2nd pair B
6	+VRL (~30Vdc)	1st pair B

Connectors:

BM50 on connector 'C',
DC50 on connector 'A' or 'C',
DS50 on connector 'B'.

Jumpers:

"Displays" are supplied directly by the Climatic board with 30Vdc. Take particular care at the path this 30V is taking when several boards are being used.

- J14 and J15 can switch on or off the direct current from the power supply:
- J14 and J15 set between 1-2:

Connectors 'A', 'B', 'C' and screw connector 'SC' are in parallel. Power is supplied to all connectors.

- J14 and J15 set between 2-3:

Connectors 'B' and 'C' are powered in parallel but connector 'A' and screw connector SC are not. Displays connected to these ports will not be powered.

If J14 and J15 are set in different positions the "terminal connection board" DT50 DOES NOT WORK and so the connected displays do not operate.

Ferrites Protection of Display

To avoid the appearance of disturbances HF, which can cause the destruction of components in the displays, you must equip the cable with a ferrite when installing it (provided by Lennox).

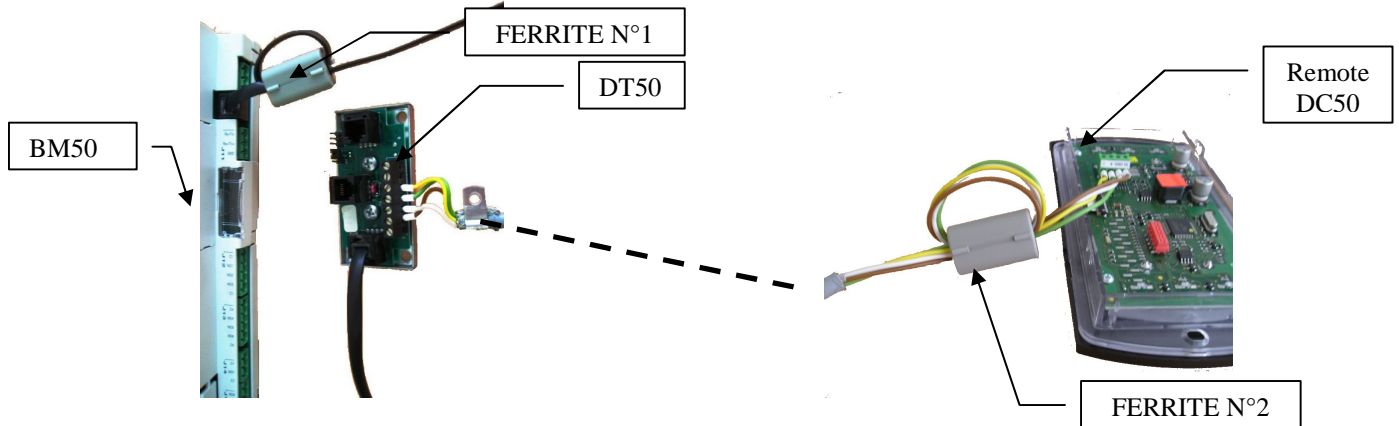

COMMUNICATION MASTER / SLAVE

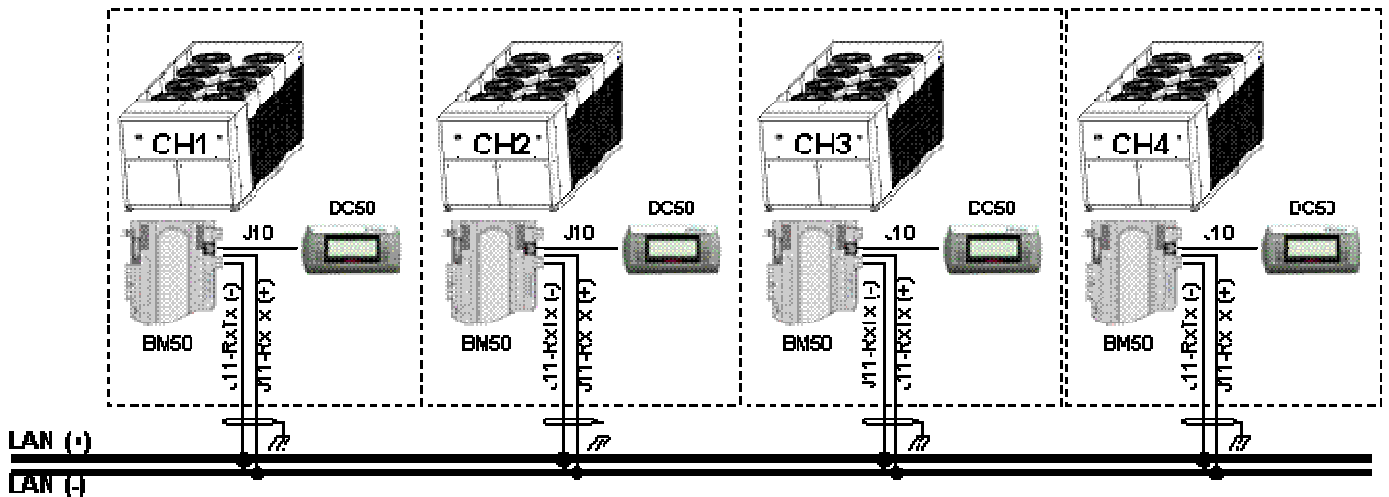

The intercard bus (pLan) is connected to Climatic™50 on the J11 connector of board BM50. A star connection is not recommended, for an optimum operation it is advised to connect a maximum of two cables per unit. Connection must be carried out by the following cable:

- Cable length up to 300m: AWG22 (0.34 mm²), 2 pairs crossed with screen.
- Cable length up to 500m: LiYCY-P (0.34 mm²), 2 pairs with general shield.
- The cable length should not exceed 500m.
- For a better electromagnetic protection, Lennox recommends the use of LiYCY-P cable.

Warning:

The power 24Vac of boards BM50 should not be connected to the earth.

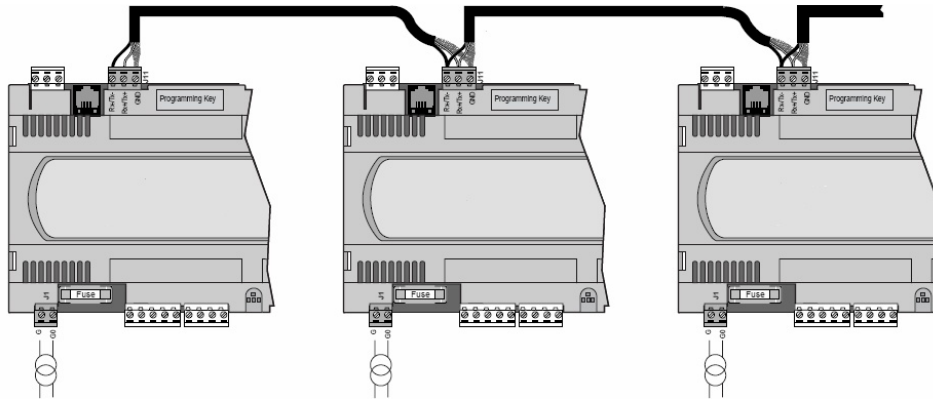

BMS COMMUNICATION

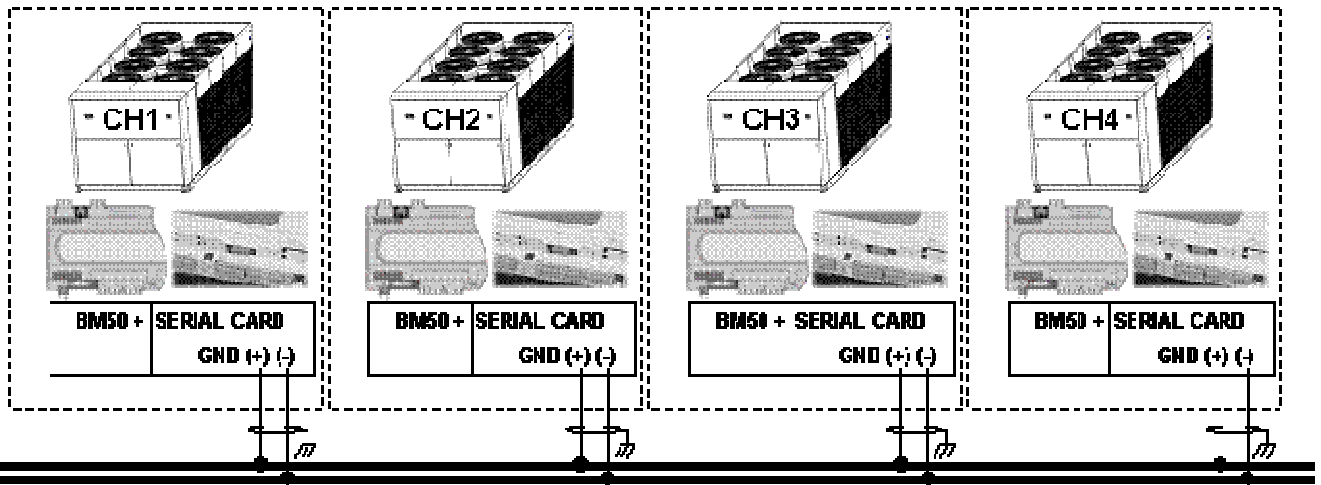

RS485 MODBUS / LON WORKS FTT 10A

The communication bus is connected to Climatic™50 Serial Card daughter board on the BM50. A star connection is not recommended, for an optimum operation it is advised to connect a maximum of two cables per unit. In case of RS485bus, a resistance of 120Ω 1/4W can be connected on the last unit between the terminals + and -.

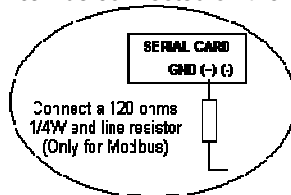

Connection must be carried out by the following cable:

- Cable length up to 300m: AWG22 (0.34 mm²), 2 pairs crossed with screen.
- Cable length up to 1000m: LiYCY-P (0.34 mm²), 2 pairs with general shield.
- The cable length should not exceed 1000m.
- For a better electromagnetic protection, LENNOX recommends the use of LiYCY-P cable.

Function

LENNOX© proposes a parametric designed software for the NEOSYS chillers & Heat pumps ranges.
 For a first use, before any operation of the unit, Climatic™50 must be set with parameters in accordance to the range, the size and the various options of the unit.

Description

The unit configuration is done with following menus (refer also to Menu Tree chapter):

(3811) → Unit range choice,

- [NAC] NEOSYS, air/water (cooling only),
- [NAH] NEOSYS, air/water reversible (heat pump),
- [NSR] Non standard request unit.

(3812) → Unit size choice,

NAC	NAH
NAC 200 STD	NAH 200 STD
NAC 230 STD	NAH 230 STD
NAC 270 STD	NAH 270 STD
NAC 300 STD	NAH 300 STD
NAC 340 STD	
NAC 380 STD	
NAC 420 STD	
NAC 480 STD	

(3813) → Unit with or without Electronic Expansion valve,

(3821) → Evaporator pumps configuration (No, single or double),

(3822) → Installation glycol percentage,

(3823) → Option free Cooling or not,

(3824) → Option heat recovery or not,

(3825) → Option power factor correction or not,

(3831), (3832), (3833), (3834) → Parametric digital output configuration of extension board BE50 1 to 4,

(3841), (3842), (3843), (3844) → Parametric digital input configuration of extension board BE50 1 to 4,

(3851), (3852), (3853), (3854) → Parametric analog input configuration of extension board BE50 1 to 4,

(3861) → Restore the standard Lennox settings or not (This parameter don't modify the settings **(38xx)**),

CLOCK SETTING

Function

Climatic™50 has a real time clock board, allowing dates and hours functionalities (weekly program, event recording,...).

Description

Menus (3121) to (3125) give the possibility of setting the internal clock.
 The day of the week is calculated by Climatic™50.
 For the countries of the Euro, the controller allows the automatic swing of the hour summer in hour winter and vice versa.
 This functionality can be cancelled by menu (3126).

- (3121) → Hour,
- (3122) → Minute,
- (3123) → Day of the month,
- (3124) → Month,
- (3125) → Year,
- (3126) → Enable automatic switch summer time / winter time.

SCHEDULING

Function

Controlling operation of the unit according to the time and day.

Description

Climatic™50 can handle 4 time zones over the 7 days of the week:

- Zone unoccupied « Night »,
- Zone A «Day A»,
- Zone B «Day B»,
- Zone C «Day C»,

Starting time (hours and minutes) of each of these zones for each days of the week, can be set using menus (3211) to (3214), (press 'PRG key to change day).

Each set point integrates the hour and minute's adjustment, thus a value of 8.3 equal 8.30 a.m.

- (3211) → Hour, minute of the night starting time (unoccupied)
- (3212) → Hour, minute of the "day A" starting time
- (3213) → Hour, minute of the "day B" starting time
- (3214) → Hour, minute of "day C" starting time

	8h00	12h00	13h50	20h30	22h00
Monday	Unoccupied	Z :A	Z :B	Z :C	Unoccupied
Tuesday					
Wednesday					
Thursday					
Friday					
Saturday					
Sunday					

For each time zone, the set following set points following can be modified:

LIST SET POINT BY ZONE	Code	DISPLAY CONFORT	DISPLAY MAINTENANCE
Change over control			
Cooling / Heating priority	(3311)	Yes	Yes
Water temperature			
Cooling Water T° Set point A	(3321)	Yes	Yes
Cooling Water T° Set point B	(3322)	Yes	Yes
Cooling Air Ambient T° Set point A	(3323)	Yes	Yes
Cooling Air Ambient T° Set point B	(3324)	Yes	Yes
Heating Water T° Set point A	(3331)	Yes	Yes
Heating Water T° Set point B	(3332)	Yes	Yes
Heating Air Ambient T° Set point A	(3333)	Yes	Yes
Heating Air Ambient T° Set point B	(3334)	Yes	Yes
Compressor enable			
Enable compressor on circuit N°1	(3411)	Yes	Yes
Enable compressor on circuit N°2	(3412)	Yes	Yes
Fan condensing			
Fan Mode Set point	(3611)	Yes	Yes
Low Noise Value Set point	(3612)	Yes	Yes
Cooling water pump(s)			
Enable pump(s)	(3711)	Yes	Yes
Programming			
Beginning of zone; each day		Yes	Yes
Start Uno	(3211)	Yes	Yes
Start z.A	(3212)	Yes	Yes
Start z.B	(3213)	Yes	Yes
Start z.C	(3214)	Yes	Yes

With the DS50, for each set point, press on the key **PRG** to change the periods and to validate the good set point for the good zone.

Note: "Monday" is considered as the first day of the week for programming the CLIMATIC™50.

Factory settings:

"Day A" activated from Monday to Saturday 6h→22h
Night mode (unoccupied) for the remaining of time, Sunday included

Function

The Climactic™50 main board (BM.50) and the optional expansion board (BE.50) offers possibilities to customize some input / output for remote control of the unit. So it is possible to customize:

- 5 digital outputs NC or NO set up with parameters (3841), (3842), (3843) and (3845),
- 6 digitals inputs set up by parameters (3851), (3852), (3853) and (3854),
- 4 analogical inputs (4-20mA or Lennox NTC temperature probe), set up with parameters (3861), (3862), (3863) and (3864).

Description

The wiring connection between the BM.50 and the BE.50 is described on the following figure:

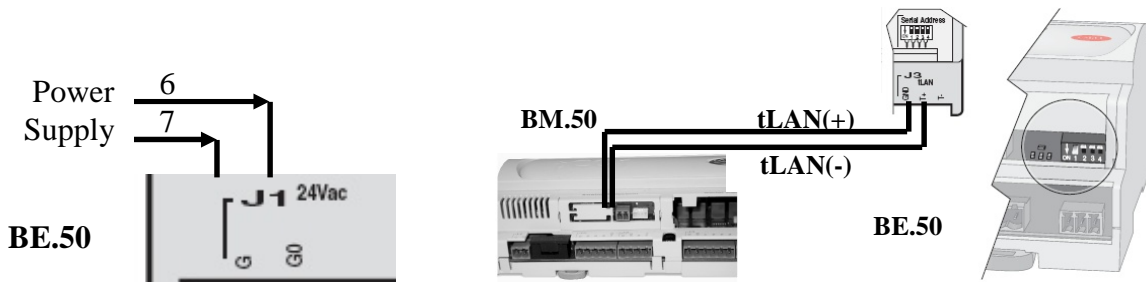

The various possibilities of customized inputs / outputs functions can be configured as follow:

*** Please, respect the wiring connections warning before connect the free input/output. (cf. "WIRING CONNECTIONS" section).**

DIGITAL OUTPUTS NC or NO – DRY CONTACTS

Electrical characteristics: Maximum commutable power: 2000VA, 250Vac.

The corresponding between the connectors and the settings is:

- (3831) → Setting for the digital output on the connector BE50-J5-NO1,
- (3832) → Setting for the digital output on the connector BE50-J6-NO2,
- (3833) → Setting for the digital output on the connector BE50-J7-NO3,
- (3834) → Setting for the digital output on the connector BE50-J8-NO4.

The following items can be used for each output:

[Not Used.]	Contact not used,
[C.1 Alarm]	Alarm on circuit N°1,
[C.2 Alarm]	Alarm on circuit N°2,
[Fans Al.]	Alarm on the condensing fan,
[Pump Al.]	Alarm on the pump,
[Flow Al.]	Alarm on the flow rate,
[Heat. Mode]	Unit operating in heating mode (Reversible unit only),
[C.1 100%]	Circuit N°1 running at full load (compressors),
[C.2 100%]	Circuit N°2 running at full load (compressors),
[U. 100%]	Unit running at full load (Circuits N°1&2),
[U. On]	Unit ready to start,
[Z:A]	Unit operating Zone A,
[Z:B]	Unit operating Zone B,
[Z:C]	Unit operating Zone C,
[Uno]	Unit operating Zone Unoccupied,
[Bms]	Unit operating Zone BMS,
[Free]	Free for BMS acting,
[Elec.H.]	Electrical heaters (up to 4) (Reversible unit only).

Free Dry Contact

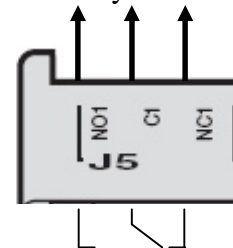

*Example
BE50-J5.NO1*

DIGITAL INPUTS – DRY CONTACTS

Electrical characteristics: 24Vac or 24Vdc, 50/60Hz.

The corresponding between the connectors and the settings is:

- (3841)** → Setting for the digital output on the connector BM50-J8-ID13,
- (3842)** → Setting for the digital output on the connector BM50-J8-ID14,
- (3843)** → Setting for the digital output on the connector BE50-J4-ID1,
- (3844)** → Setting for the digital output on the connector BE50-J4-ID2,
- (3845)** → Setting for the digital output on the connector BE50-J4-ID3,
- (3846)** → Setting for the digital output on the connector BE50-J4-ID4.

The following items can be used for each input:

[Not Used]	Input not used,
[Sw Setpoint]	Switch to the second cooling / heating set point,
[Sw Cool.]	Switch the unit to the cooling mode,
[Sw Heat.]	Switch the unit to the heating mode,
[C1 Disable]	Disable the circuit N°1 (all compressors),
[C2 Disable]	Disable the circuit N°2 (all compressors),
[Circ. 1-Cp. 1]	Disable the compressor N°1 on the circuit N°1,
[Circ. 1-Cp. 2]	Disable the compressor N°2 on the circuit N°1,
[Circ. 1-Cp. 3]	Disable the compressor N°3 on the circuit N°1,
[Circ. 2-Cp. 1]	Disable the compressor N°1 on the circuit N°2,
[Circ. 2-Cp. 2]	Disable the compressor N°2 on the circuit N°2,
[Circ. 2-Cp. 3]	Disable the compressor N°3 on the circuit N°2,
[Z:A]	Unit operating Zone A,
[Z:B]	Unit operating Zone B,
[Z:C]	Unit operating Zone C,
[Uno]	Unit operating Zone Unoccupied,
[Bms]	Unit operating Zone BMS,
[Free]	Free for BMS system information,
[Elec.H.]	Electrical heaters fault (Reversible unit only).

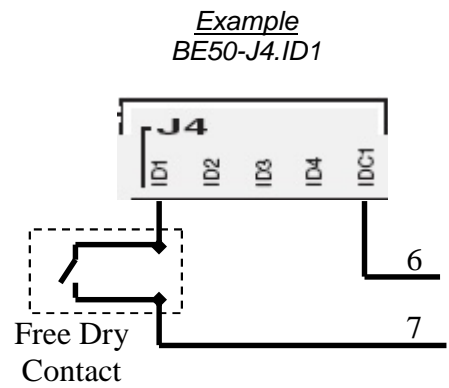

ANALOG INPUTS

Electrical characteristics: The analog input on the same connector J9 (B1 and B2) must use the same type of signal (4/20mA or NTC). As well, the analog input on the same connector J10 (B3 and B4) must use the same type of signal (4/20mA or NTC).

The corresponding between the connectors and the settings is:

- (3851)** → Setting for the analog input on the connector BE50-J9-B1,
- (3852)** → Setting for the analog input on the connector BE50-J9-B2,
- (3853)** → Setting for the analog input on the connector BE50-J10-B3,
- (3854)** → Setting for the analog input on the connector BE50-J10-B4.

The following items can be used for each input:

[Not Used]	Not used,
[S.P Water]	Water set point 4-20mA signal,
[S.P Offset]	Water set point offset 4-20mA signal,
[Free NTC]	Free temperature probe connection.

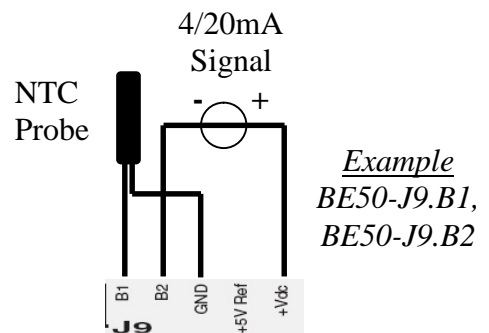

Water set point cooling / heating 4-20mA signal:

The 4-20mA signal sent to the unit is linearly converted using the 2 water temperature set points. To increase the precision, you can customize 2 range of water set point according to the cooling or heating mode operating.

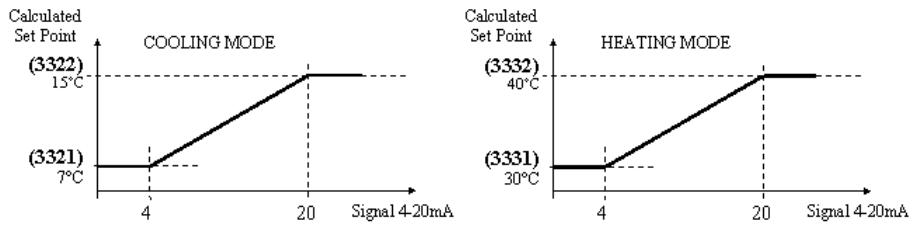

Water set point offset 4-20mA signal:

The 4-20mA signal sent to the unit is linearly converted using a -5K to +5K range of temperature set point.

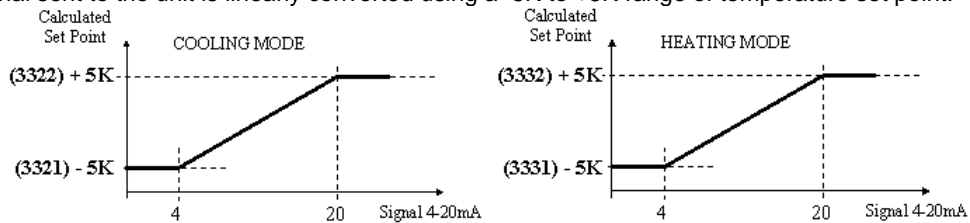

Free temperature probe connection:

Lennox NTC sensor: The measured value will be displayed on following addresses (2171), (2172), (2173) or (2174).

Function

The Climactic™50 main board (BM.50) offers free dry contacts to control the unit. These free dry contacts are connected directly to terminals (orange colour) identified as follow:

- [824 - 825] : 24V relay customers power supply (Option),
- [826 - 827] : 24V power ON the unit (Option),
- [804 - 805] : Remote alarm reset (NC = Enable Reset),
- [808 - 809] : Water evaporator customer flow switch,
- [890 - 891] : Remote ON / OFF of the unit.
- [870 - 871 - 872] : Alarm relay (NC = Alarm OFF).

Connection

The following figure described how to connect the free dry contacts of Climactic™50. For the contacts [824 - 825] and [826 - 827], refers to the electrical diagram.

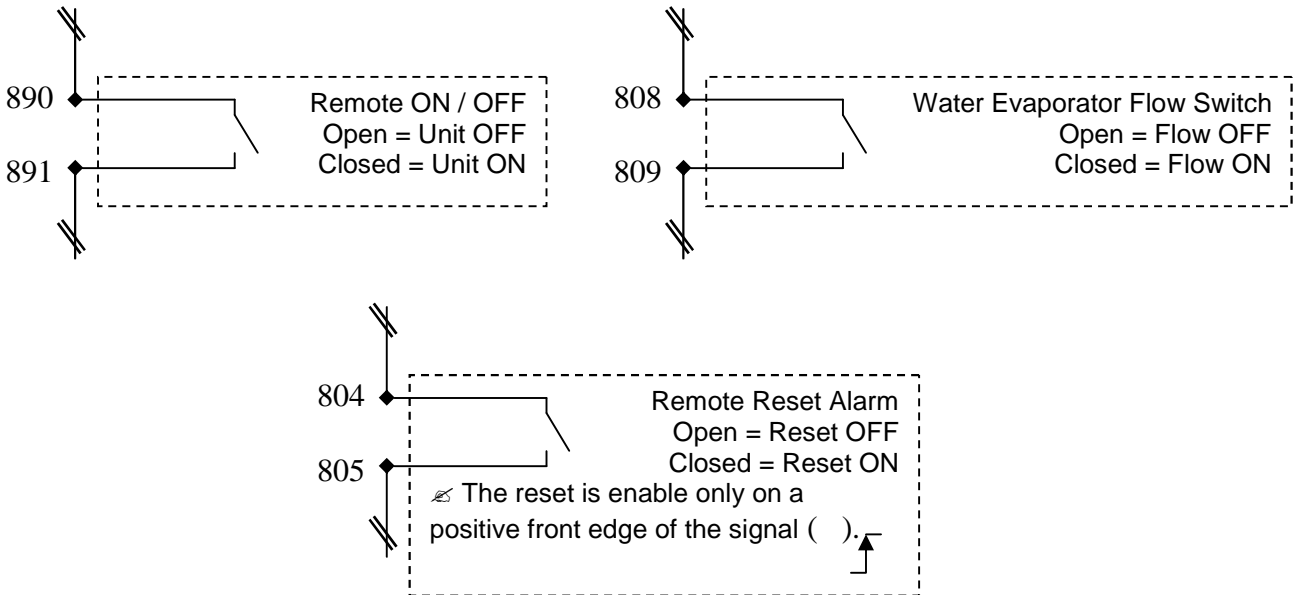

Function

It may be necessary to change the address of the BM50 card on the pLan network – mainly in the case of Master/Slave installation. To do this, use the following procedure:

Description

Set the address of the DS/DC50 display to 0:

Sds.1



Access the configuration mode by pressing the buttons **↑ ↓ ↵** , for at least 5 seconds until the Sds.1 screen appears:
Press button **↵** to position the cursor over the 'Setting' line
With the **↑** or **↓** button, set the address of the display to 00 (instead of the standard value of 32) and confirm with button **↵**

Sds.2



The Sds.2 screen appears.

Changing the address of BM50

Sds.3

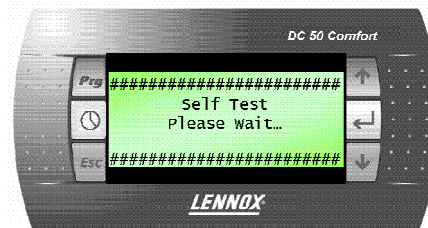

Switch the power supply to the BM50 card off, then on again after 5 seconds. When the Sds.3 screen appears, press, the 'Alarm' and **↑** buttons for 5 seconds.

Sds.4



The Sds.4 screen appears.
Press the button **↵** to position the cursor over the 'pLan address' line. With button **↑** or **↓** set the desired pLan address (1 to 12) and confirm with button **↵**.

Function

Ensure there is a good connection between the BM50 and its displays

Description

For each Climatic™50 card the following setting must be made using the DS50.

Disconnect the pLan bus at J10 and J11 and connect the DS50, directly to J10 of the BM50;

Sds.1



Access the configuration mode by pressing buttons ↑ ↓ ← , for at least 5 seconds until the Sds.1 screen appears:
 Press the button ← to position the cursor over the 'Setting' line
 Press button ← again to position the cursor over the 'I/O board address' line
 With button ↑ or ↓, replace '- ' with the address of the BM50 connected and confirmed with button ←

Sds.5



The Sds.5 screen appears.
 Press button ←

Sds.6 (for the DC50)



The Sds.6 screen appears.
 The field "P:XX " shows the selected pLan address. In this example the value "01" has been selected.
 The fields in the "Adr" column represent the addresses of the terminal displays associated with this BM50, while the "Priv/Shared" column indicates the status of the selected terminal.
 Pr: Private
 Sh: Shared
 Sp: Shared Printer (N/A)

Move the cursor from field to field using button ←
 Select the value desired using button ↑ or ↓.
 To exit the configuration procedure and save the data, select the "OK?No", field, choose "Yes" using buttons ↑ or ↓ and confirm by pressing ←

Trm1 is reserved to allocate the **DC50** to the BM50.
 Its value differs depending on the pLan address of the BM50
 (See the opposite table)
 Its status is always 'Pr'
Trm3 is reserved to allocate the **DS50** to the BM50.
 Its value is always 32
 Its status is always 'Sh'

pLan address of the BM50	Trm1 DC50
1	17 pr
2	18 pr
3	19 pr
4	20 pr

If the terminal remains inactive (no button is pressed) for 30 seconds, the configuration procedure is aborted automatically.



Function

This display is connected remotely; it is intended for users with no technical knowledge. This display gives access to general operating data of the unit. It does not give access to detailed operating data. It can be used to set or change the programming of the various time periods and the temperature set point for each period. It also has the ability to set a 3 hours override and force an unoccupied mode, or any other different time periods, for a maximum of 7 days. It displays a real time clock and the various fault signals.

Buttons

	'Prg' Access set points		'Up' Access overrides or increase values
	'Clock' Access the clock		'Enter', Confirms the selection
	'Esc' Return to the previous display		'Down' Access overrides or decrease values

Brightness/Contrast

The display has a set contrast, but this can be adjusted manually. For manual adjustment of the contrast, press the 'Prg' and 'Clock' buttons simultaneously and press buttons ↑ or ↓ to increase or reduce the contrast.

Configuration of the terminal address

Sdc.1



The address of the terminal DC50 must be checked after having switching on the card.

Access the configuration mode by pressing buttons ↑ ↓ ← simultaneously for at least 5 seconds, until the Sdc.1 screen appears.

Press the 'Enter' button to position the cursor over the 'Setting' line. With button ↑ or ↓, set the address of the display. See table below for the DC50, then confirm with button ←

pLan address with BM50 connected	DC50 Address
1	17 (local display) 21 (remote display)
2	18 (local display) 22 (remote display)
3	19 (local display) 23 (remote display)
4	20 (local display) 24 (remote display)

Sdc.2



The Sdc.2 screen appears.

If after 5 seconds the display is not correct; Return to the configuration mode by pressing buttons \uparrow \downarrow \leftarrow simultaneously for at least 5 seconds until the Sdc.1 screen appears.

Press button \leftarrow to position the cursor over the 'Setting' line

Press, the button \leftarrow again to position the cursor over the 'I/O board address' line

With the button \uparrow or \downarrow , replace '- -' with the address of the BM50 connected and confirm with button \leftarrow

Then repeat the procedure "Allocation of Displays to the BM50"

Main screen

Sdc.3



On the first line, as a double display:

Outlet temperature

On the second line:

Outside air temperature

Current time period (Z:A, Z:B, Z:C, Uno)

Mode of operation (Heat, Dead or Cool)

3 Hours override

This function can be used to override either the desired outlet temperature for 3 hours.

Sdc.3



If an override is active, the time period display is alterned with the 'Ove' symbol.

The 'Esc' button is used to cancel the override mode.

From the main screen, press button \uparrow or \downarrow

Sdc.4

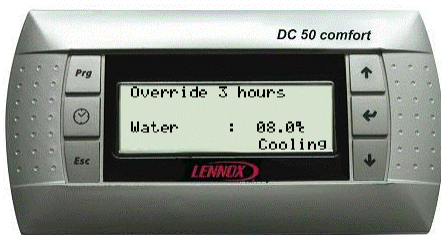

Screen Sdc.4 is used to change the override values

The present time period is shown on the 2nd line. This period will remain fixed for 3 hours.

Press \leftarrow to position the cursor over the 'Water SP' line

With button \uparrow or \downarrow to set the desired temperature and confirm with the 'Enter' button.

Press \leftarrow to position the cursor over the 'Mode SP' line

With button \uparrow or \downarrow to set the desired mode and confirm with button \leftarrow

The DC50 returns to the main display.

A single press on the 'Esc' button cancels the changes and returns to the main screen.

1 week override

This function overrides the operating periods for a maximum of 7 days.

Sdc.5



From the Sdc.3 screen, press button \leftarrow twice to position the cursor over the 'Override a period' line

With button \uparrow or \downarrow set the period desired and confirm with button \leftarrow .

The Sdc.5 screen appears.

With button \uparrow or \downarrow set the days of the week to the period desired and confirm with button \leftarrow .

In this example, the unit will remain in the unoccupied period on Tuesday

when confirmed until midnight on Thursday.

It will revert back to the main screen after 15 seconds without any activity.

Clock Menu

These screens are used to display and change the time and date on the BM50.

Sdc.6



From the main screen, press the 'clock' button. The Sdc.6 screen displays the time and date.

To change the time or date:
 Press **↵** to position the cursor over the time.
 With button **↑** or **↓** set the time and confirm with button **↵**
 Position the cursor over 'minutes'.
 With button **↑** or **↓** set the minutes and confirm with button **↵**
 Position the cursor over 'month'.
 With button **↑** or **↓** set the month and confirm with button **↵**
 Position the cursor over 'year'.
 With button **↑** or **↓** set the year and confirm with button **↵**
 Position the cursor over 'hours'.

Pressing the 'Esc' returns to the main screen

It will revert back to the main screen after 15 seconds without any activity.

"Programming" Menu

These screens are used to display and change the set points of the BM50 for each time period.

Sdc.7

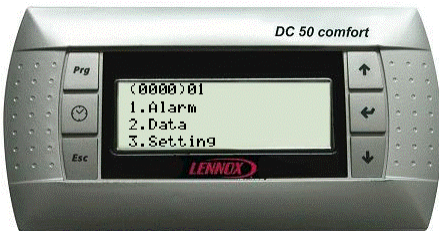

From the main screen, press the "Prg" button, Screen Sdc.7 displays the menu.

With button **↑** or **↓** to select the "Setting" item and confirm with button **↵**. Pressing the 'Esc' returns to the main screen.

Sdc.8



The next screen display the unit status for each zone by pressing on the "Clk" button.

Sdc.9.a

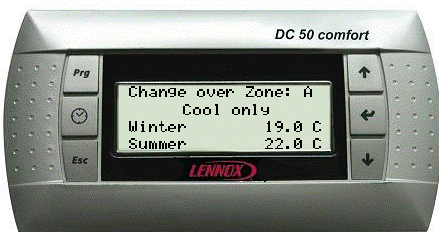

From the Sdc.8 screen; press the 'Prg' button. Screen Sdc.9.a displays the change over mode. Position the cursor over "Mode"
 With button **↑** or **↓**, set the desired mode for period A and confirm with button **↵**.
 With button **↑** or **↓**, set the winter outside temperature the period A and confirm with button **↵**.
 With button **↑** or **↓**, set the summer outside temperature the period A and confirm with button **↵**.
 Press the button 'Clk' to change the time period.
 Repeat the procedure for each time period (Z:A, Z:B, Z:C, Uno).

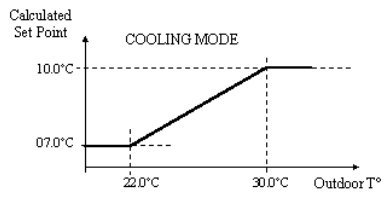
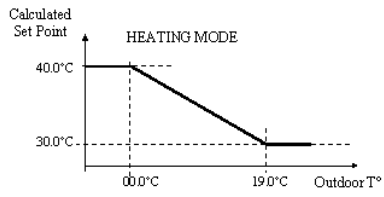

Sdc.9.b

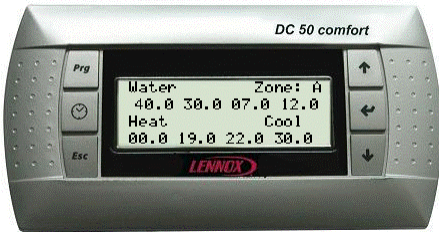

From the Sdc.9.a screen; press the 'Prg' button
 Screen Sdc.9.b displays the water set points.
 With button ↑ or ↓ set the desired temperature for period A and confirm with button ↵.
 Press the button 'Clk' to change the time period.
 Repeat the procedure for each time period (Z:A, Z:B, Z:C, Uno).

Sdc.9.c



From the Sdc.9.b screen; press the 'Prg' button
 Screen Sdc.9.c displays the period settings.
 Position the cursor over period A
 With button ↑ or ↓ set the start time for period A and confirm with button ↵.
 Position the cursor over period B.
 With button ↑ or ↓ set the start time for period B and confirm with button ↵.
 Position the cursor over period C.
 With button ↑ or ↓ set the start time for period C and confirm with button ↵.
 Position the cursor over the Uno period.
 With button ↑ or ↓ set the unoccupied period and confirm with button ↵.
 Position the cursor over period A.
 Pressing the 'Esc' returns to the main screen.
 Select the day of the week by repeatedly pressing the 'Clock' button

It will revert back to the main screen after 15 seconds without any activity.

Major Alarm

Sdc.10



In the event of activation of a fault on the unit, screen Sdc.10 is displayed.
 Button 'Prg' is illuminated.
 All buttons are deactivated

The only way to regain control of the DC50 is to resolve the fault on the unit.
 To display the alarm history of the unit, press button ↵

Sdc.11



The history can store the last 32 alarms occurring on the unit.
 Each alarm is memorised at the date and time of occurrence of the fault.
 An active alarm is signified by the symbol '*'.
 An acknowledged alarm is signified by the symbol '='.
 Each alarm is signified by a 3 digit code (see ERROR CODES ALARMS section)

Sdc.12

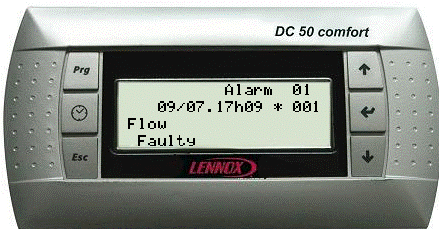

Press the 'Alarm' button to reset all the alarms, if possible
 The number of active alarms returns to 0, no active alarm is shown in the menu, and the 'Alarm' button is no longer illuminated.

To highlight the title of the error code, position the cursor over the line desired with buttons ↑ or ↓, then confirm with the 'Enter' button

Use the 'Esc' button to return to the previous levels.

Start/stop

Sdc.13



From the main screen, press the **↵** button
The Sdc.13 screen appears.

Sdc.14



To stop the unit:
With button **↑** or **↓** set the value to 'Yes' and confirm with button **↵**
The unit stops and the Sdc.14 screen appears

WARNING: Switching off the unit disables all the safety devices

Pressing the 'Esc' returns to the main screen.

Sdc.15



If the unit is stopped, the Sdc.15 screen appears.
To start the unit, press button **↵**
The unit starts and the main screen appears.

Navigation in the screens

Main menu (0000)

S.5

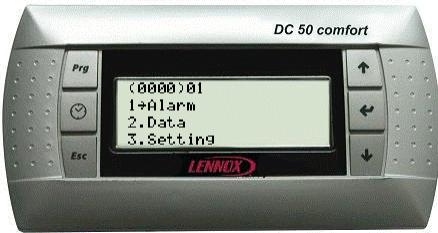

The four digits in brackets indicate the number of the current menu. The two digits beside the brackets indicate the pLan number of the selected card. The display on the right indicates the period of operation and the current time conditions.

S.6

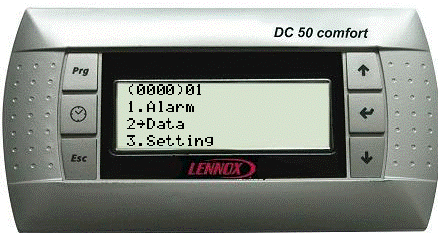

Scrolling the menus
Press button \uparrow or \downarrow to move the cursor upwards or downwards. The item selected is displayed in CAPITAL letters preceded by the symbol ' \rightarrow '. It can then be selected by pressing button \leftarrow .
A '+' or '++' symbol beside the number of the first or third line indicates the existence of one or more additional lines.

Menu Data (2000)

S.7

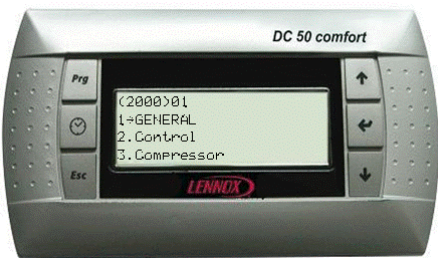

Example: S.5 to S.9 show how the menu tree changes each time button \leftarrow from the menu is pressed

- \leftarrow Data (2000)
 - \leftarrow General (2100)
 - \leftarrow Temperature (2110)
 - (2111) Outside temperature 16.0°C
 - (2112) Inlet temperature 12.0°C
 - (2113) Outlet temperature 07.0°C

Press "Esc" at any time sends to return to the previous level of the menu tree. In the example shown above, "Esc" must be pressed 3 times to return to the main menu (0000)

S.8

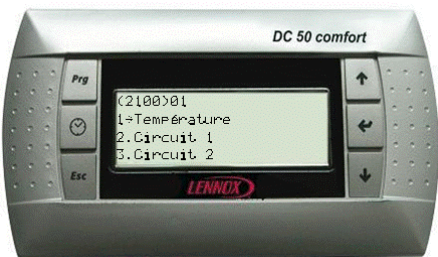

S.9

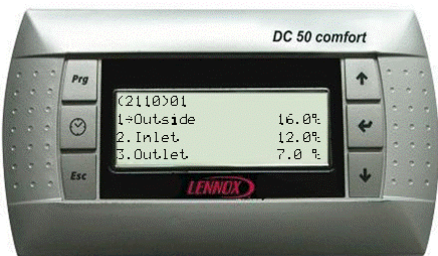

Menu	Item	Menu	Item	Menu	Item	Menu	Item	UNIT	MIN	MAX	FACTORY
1000	ALARM										
2000	DATA	2100	GENERAL	2110	TEMPERATURE	2111	OUTSIDE	°C			
						2112	INLET	°C			
						2113	OFFSET	°C			
						2114	OUTSIDE	°C			
				2120	CIRCUIT 1	2121	T°SUPERHEAT	°C			
						2122	T°COND	°C			
						2123	T°SATU	°C			
						2124	T°SUCT	°C			
						2125	P.COND	Bar			
						2126	P.SATU	Bar			
						2127	T°DISCH.11	°C			
						2128	T°DISCH.12	°C			
				2130	CIRCUIT 2	2131	T°SUPERHEAT	°C			
						2132	T°COND	°C			
						2133	T°SATU	°C			
						2134	T°SUCT	°C			
						2135	P.COND	Bar			
						2136	P.SATU	Bar			
						2137	T°DISCH.21	°C			
						2138	T°DISCH.22	°C			
				2140	OTHER	2141	SW ON/OFF	OFF/ON			
						2142	SW FLOW	OFF/ON			
						2143	SW RESET	OFF/ON			
						2144	SW INOC	OFF/ON			
				2150	OUT CUSTOM	2151	BE50.1	OFF/ON			
						2152	BE50.2	OFF/ON			
						2153	BE50.3	OFF/ON			
						2154	BE50.4	OFF/ON			
				2160	IN CUSTOM	2161	BM50.1	OFF/ON			
						2162	BM50.2	OFF/ON			
						2163	BE50.1	OFF/ON			
						2164	BE50.2	OFF/ON			
						2165	BE50.3	OFF/ON			
						2166	BE50.4	OFF/ON			
				2170	IN % CUSTOM	2171	BE50.1	°C / mA			
						2172	BE50.2	°C / mA			
						2173	BE50.3	°C / mA			
						2174	BE50.4	°C / mA			
		2200	CONTROL	2210	COOL WATER	2211	RSP COOL	°C			
						2212	CAPA.COOL	%			
						2213	OFFSET	°C			
						2214	SW 2° SP	OFF/ON			
				2220	HEAT WATER	2221	RSP HEAT	°C			
						2222	CAPA.HEAT	%			
						2223	OFFSET	°C			
						2224	SW 2° SP	OFF/ON			
		2300	COMPRESSOR	2310	CIRC.1.COMP.1	2311	CONFIG.	List			
						2312	STATUS	List			
						2313	SW STATE	OFF/ON			
						2314	SW RELAY	OFF/ON			
						2315	SW HP	OFF/ON			
						2316	SW LP	OFF/ON			
						2317	VALVE	OFF/ON			
						2318	RUN TIME	Hour			
				2320	CIRC.1.COMP.2	2321	CONFIG.	List			

DS50 MENU TREE



Menu	Item	Menu	Item	Menu	Item	Menu	Item	UNIT	MIN	MAX	FACTORY
						2322	STATUS	List			
						2323	SW STATE	OFF/ON			
						2324	SW RELAY	OFF/ON			
						2325	SW HP	OFF/ON			
						2326	SW LP	OFF/ON			
						2327	VALVE	OFF/ON			
						2328	RUN TIME	Hour			
				2330	CIRC.1.COMP.3	2331	CONFIG.	List			
						2332	STATUS	List			
						2333	SW STATE	OFF/ON			
						2334	SW RELAY	OFF/ON			
						2335	SW HP	OFF/ON			
						2336	SW LP	OFF/ON			
						2337	VALVE	OFF/ON			
						2338	RUN TIME	Hour			
				2340	CIRC.2.COMP.1	2341	CONFIG.	List			
						2342	STATUS	List			
						2343	SW STATE	OFF/ON			
						2344	SW RELAY	OFF/ON			
						2345	SW HP	OFF/ON			
						2346	SW LP	OFF/ON			
						2347	VALVE	OFF/ON			
						2348	RUN TIME	Hour			
				2350	CIRC.2.COMP.2	2351	CONFIG.	List			
						2352	STATUS	List			
						2353	SW STATE	OFF/ON			
						2354	SW RELAY	OFF/ON			
						2355	SW HP	OFF/ON			
						2356	SW LP	OFF/ON			
						2357	VALVE	OFF/ON			
						2358	RUN TIME	Hour			
				2360	CIRC.2.COMP.3	2361	CONFIG.	List			
						2362	STATUS	List			
						2363	SW STATE	OFF/ON			
						2364	SW RELAY	OFF/ON			
						2365	SW HP	OFF/ON			
						2366	SW LP	OFF/ON			
						2367	VALVE	OFF/ON			
						2368	RUN TIME	Hour			
		2400	EEV	2410	CIRCUIT 1	2411	CONFIG.	List			
						2412	STATUS	OFF/ON			
						2413	POSITION	---			
				2420	CIRCUIT 2	2421	CONFIG.	List			
						2422	STATUS	OFF/ON			
						2423	POSITION	---			
		2500	FAN	2510	CIRCUIT 1	2511	CONFIG.	List			
						2512	STATUS	List			
						2513	SW STATE	OFF/ON			
						2514	MODE	List			
						2515	VALUE	°C			
						2516	MAXIMUM	%			
						2517	CAPACITY	%			

Menu	Item	Menu	Item	Menu	Item	Menu	Item	UNIT	MIN	MAX	FACTORY
				2520	CIRCUIT 2	2521	CONFIG.	List			
						2522	STATUS	List			
						2523	SW STATE	OFF/ON			
						2524	MODE	List			
						2525	VALUE	°C			
						2526	MAXIMUM	%			
						2527	CAPACITY	%			
		2600	OPTION	2610	COOL PUMP	2611	CONFIG.	List			
						2612	STATUS 1	List			
						2613	STATUS 2	List			
						2614	SW STATE	OFF/ON			
						2615	SW RELAY 1	OFF/ON			
						2616	SW RELAY 2	OFF/ON			
						2617	RUN TIME 1	H			
						2618	RUN TIME 2	H			

ModBus, Trend, BACnet & Carel

LOGICAL DATA

@ (hexa)	@ (deci)	R/W	Unit	Description	DS50
01H	1	R/W	0/1	[On/Off] General On/Off of the unit [Off] Unit OFF - [On] Unit ON	3111
02H	2	R/W	0/1	[Reset] Discharges the safety measures of the unit	3113
03H	3	R/W	0/1	[BMS] BMS On/Off of the unit [Off] Unit OFF - [On] Unit ON	3112 BMS
04H	4	R/W	0/1	<i>not used</i>	
05H	5	R/W	0/1	[BMS] Activation of the Inoccupation mode : [Off] Occupation mode - [On] Inoccupation mode	3925 Unoc
06H	6	R	0/1	<i>not used</i>	
07H	7	R	0/1	<i>not used</i>	
08H	8	R	0/1	<i>not used</i>	
09H	9	R	0/1	<i>not used</i>	
0AH	10	R	0/1	<i>not used</i>	
0BH	11	R	0/1	<i>not used</i>	
0CH	12	R	0/1	<i>not used</i>	
0DH	13	R	0/1	<i>not used</i>	
0EH	14	R	0/1	<i>not used</i>	
0FH	15	R	0/1	<i>not used</i>	
10H	16	R/W	0/1	[Clock] Read / Update the internal clock board of the BM50 [OFF] Read hour & minute - [ON] Write hour & minute	...
11H	17	R	0/1	<i>not used</i>	
12H	18	R/W	0/1	[Dry contact] Digital Output, Free 1, BE50-J5-NO1	2151
13H	19	R/W	0/1	[Dry contact] Digital Output, Free 2, BE50-J6-NO2	2152
14H	20	R/W	0/1	[Dry contact] Digital Output, Free 3, BE50-J7-NO3	2153
15H	21	R/W	0/1	[Dry contact] Digital Output, Free 4, BE50-J8-NO4	2154
16H	22	R	0/1	<i>not used</i>	
17H	23	R	0/1	<i>not used</i>	
18H	24	R	0/1	<i>not used</i>	
19H	25	R	0/1	<i>not used</i>	
1AH	26	R	0/1	<i>not used</i>	
1BH	27	R	0/1	<i>not used</i>	
1CH	28	R	0/1	<i>not used</i>	
1DH	29	R	0/1	<i>not used</i>	
1EH	30	R	0/1	<i>not used</i>	
1FH	31	R	0/1	<i>not used</i>	
20H	32	R	0/1	<i>not used</i>	
21H	33	R	0/1	[Alarm] General alarm	
22H	34	R	0/1	[On/Off] Pump, 1	2615
23H	35	R	0/1	[On/Off] Pump, 2	2616
24H	36	R	0/1	[On/Off] Compressor 1, Circuit 1	2316
25H	37	R	0/1	[On/Off] Compressor 2, Circuit 1	2326

26H	38	R	0/1	[On/Off] Compressor 3, Circuit 1	2336
27H	39	R	0/1	[On/Off] Compressor, Heat pump, Circuit 1	2317
28H	40	R	0/1	[On/Off] Compressor 1, Circuit 2	2346
29H	41	R	0/1	[On/Off] Compressor 2, Circuit 2	2356
2AH	42	R	0/1	[On/Off] Compressor 3, Circuit 2	2366
2BH	43	R	0/1	[On/Off] Compressor, Heat pump, Circuit 2	2347
2CH	44	R	0/1	<i>not used</i>	
2DH	45	R	0/1	<i>not used</i>	
2EH	46	R	0/1	<i>not used</i>	
2FH	47	R	0/1	<i>not used</i>	
30H	48	R	0/1	<i>not used</i>	
31H	49	R	0/1	[Dry contact] Digital Input, Free 1, BM50-J8-ID13	2161
32H	50	R	0/1	[Dry contact] Digital Input, Free 2, BM50-J8-ID14	2162
33H	51	R	0/1	[Dry contact] Digital Input, Free 1, BE50-J4-ID1	2163
34H	52	R	0/1	[Dry contact] Digital Input, Free 2, BE50-J4-ID2	2164
35H	53	R	0/1	[Dry contact] Digital Input, Free 3, BE50-J4-ID3	2165
36H	54	R	0/1	[Dry contact] Digital Input, Free 4, BE50-J4-ID4	2166
37H	55	R	0/1		
38H	56	R	0/1		
39H	57	R	0/1		
3AH	58	R	0/1		
3BH	59	R	0/1		
3CH	60	R	0/1		
3DH	61	R	0/1		
3EH	62	R	0/1	[Water] Cool Mode Operating	
3FH	63	R	0/1	<i>not used</i>	
40H	64	R	0/1	[Water] Heat Mode Operating	

ANALOGIC DATA

@ (hexa)	@ (deci)	R/W	Unit	Description	DS50
01H	1	R/W	1 = 1 s	[BMS] Activation of the control by a computer or an automat. Mode BMS is activated if this value is different from zero. This value is decreased every second.	3934
02H	2	R/W	1 = 1	[Unit] without pump: 0=Started; 1=Stopped [Unit] with pump: 1=Stopped; 2=P1 Only; 3=P2 Only; 4=P1-N P2-S; 5=P2-N P1-S; 6=P1/P2 by clock	3711 BMS
03H	3	R/W	1 = 1	[Unit] Change-over: 0=Cool. Only; 1=Heat. Only; 2=Auto. Pump; 3=Auto. No Pump	3311 BMS
04H	4	R	1 = 1	<i>not used</i>	
05H	5	R/W	10 = 1.0°C	[Occupation][Water SP] Required water temperature in °C Cooling set point.	3321 BMS
06H	6	R/W	10 = 1.0°C	[Occupation][Water SP] Required water temperature in °C Heating set point.	3331 BMS
07H	7	R/W	10 = 1.0°C	[Inoccupation][Water SP] Required water temperature in °C Cooling set point.	3321 Uno
08H	8	R/W	10 = 1.0°C	[Inoccupation][Water SP] Required water temperature in °C Heating set point.	3331 Uno
09H	9	R		<i>not used</i>	
0AH	10	R		<i>not used</i>	
0BH	11	R		<i>not used</i>	
0CH	12	R/W	1 = 1h	[Clock] Hour	3121
0DH	13	R/W	1 = 1m	[Clock] Minute	3122
0EH	14	R/W	1 = 1	[Clock] Day of the month	3123
0FH	15	R/W	1 = 1	[Clock] Month	3124
10H	16	R/W	1 = 2001	[Clock] Year	3125
11H	17	R/W	10 = 1.0°C	[BMS] Outlet temperature coming from the BMS.	
12H	18	R/W		<i>not used</i>	
13H	19	R/W	10 = 1.0°C	[BMS] Outdoor temperature coming from the BMS.	
14H	20	R/W		<i>not used</i>	
15H	21	R/W		<i>not used</i>	
16H	22	R/W		<i>not used</i>	
17H	23	R/W		<i>not used</i>	
18H	24	R/W		<i>not used</i>	
19H	25	R/W		<i>not used</i>	
1AH	26	R/W		<i>not used</i>	
1BH	27	R/W		<i>not used</i>	
1CH	28	R/W		<i>not used</i>	
1DH	29	R/W		<i>not used</i>	
1EH	30	R/W		<i>not used</i>	
1FH	31	R/W		<i>not used</i>	
20H	32	R/W		<i>not used</i>	
21H	33	R	1 = 1	[Alarm] Code Error	...
22H	34	R	10 = 1.0°C	[Temperature] Inlet, Water	2112
23H	35	R	10 = 1.0°C	[Temperature] Outdoor, Air	2111

BMS ADDRESS TABLES



24H	36	R	10 = 1.0°C	[Temperature] Outlet, Water	2113
25H	37	R	10 = 1.0b	[Temperature] High, Circuit 1	2122
26H	38	R	10 = 1.0b	[Temperature] Low, Circuit 1	2123
27H	39	R	10 = 1.0b	[Temperature] High, Circuit 2	2132
28H	40	R	10 = 1.0b	[Temperature] Low, Circuit 2	2133
29H	41	R	10 = 1.0b	[EEV] Saturated evaporation temperature, Circuit 1	2124
2AH	42	R	10 = 1.0b	[EEV] Saturated evaporation temperature, Circuit 2	2134
2BH	43	R	10 = 1.0b	<i>not used</i>	
2CH	44	R	10 = 1.0b	<i>not used</i>	
2DH	45	R	1 = 1%	[% of opening] Fan, Modulation, Circuit 1	2517
2EH	46	R	1 = 1%	[% of opening] Fan, Modulation, Circuit 2	2527
2FH	47	R	1 = 1%	<i>not used</i>	
30H	48	R	1 = 1%	<i>not used</i>	
31H	49	R	10 = 1.0°C	[Temperature] Temperature, Free 1, BE50-J9-B1	2171
32H	50	R	10 = 1.0°C	[Temperature] Temperature, Free 2, BE50-J9-B2	2172
33H	51	R	10 = 1.0°C	[Temperature] Temperature, Free 3, BE50-J10-B3	2173
34H	52	R	10 = 1.0°C	[Temperature] Temperature, Free 4, BE50-J10-B4	2174
35H	53	R	1 = 1	<i>not used</i>	
36H	54	R	1 = 1	<i>not used</i>	
37H	55	R	1 = 1	<i>not used</i>	
38H	56	R	1 = 1	<i>not used</i>	
39H	57	R	10 = 1.0°C	[EEV] Current superheating value, Circuit 1	2121
3AH	58	R	10 = 1.0°C	[EEV] Current superheating value, Circuit 2	2131
3BH	59	R	10 = 1.0°C	<i>not used</i>	
3CH	60	R	10 = 1.0°C	<i>not used</i>	
3DH	61	R	10 = 1.0°C	<i>not used</i>	
3EH	62	R	10 = 1.0°C	<i>not used</i>	

<p>3FH</p>	<p>63</p>	<p>R</p>	<p>10 = 1.0</p>	<p>[Alarm] bit.0 = Flow switch bit.1 = High Temperature, Outlet bit.2 = Low Temperature, Inlet bit.3 = Low Temperature, Outlet bit.4 = High Temperature, Inlet bit.5 = Pump, 1 bit.6 = Pump, 2 bit.7 = Real Time Clock bit.8 = BE50 bit.9 = <i>not used</i> bit.10 = Probes & Sensors bit.11 = Fans, Condenser, Circuit 1 bit.12 = Fans, Condenser, Circuit 2 bit.13 = Fans, Condenser, Circuit 3 bit.14 = <i>not used</i> bit.15 = <i>not used</i></p>	
<p>40H</p>	<p>64</p>	<p>R</p>	<p>10 = 1.0</p>	<p>[Alarm] bit.0 = Compressor, Circuit 1, Electric Protection bit.1 = Compressor, Circuit 1, High Pressure bit.2 = Compressor, Circuit 1, Low Pressure or Freeze protection bit.3 = Compressor, Circuit 2, Electric Protection bit.4 = Compressor, Circuit 2, High Pressure bit.5 = Compressor, Circuit 2, Low Pressure or Freeze protection bit.6 = <i>not used</i> bit.7 = <i>not used</i> bit.8 = <i>not used</i> bit.9 = <i>not used</i> bit.10 = <i>not used</i> bit.11 = <i>not used</i> bit.12 = Compressor, Circuit 1, Electronic Expansion Valve bit.13 = Compressor, Circuit 2, Electronic Expansion Valve bit.14 = <i>not used</i> bit.15 = <i>not used</i></p>	

LonWorks

LOGICAL DATA

Type	BM50 Index	Name NV	Type NV	Direction	Index	Description	DS50
DGT	1	I_Sp_On_Unit	95	input	415	[On / Off] Unit	3111
DGT	1	O_Sp_On_Unit	95	output	415		
DGT	2	I_Sp_Reset	95	input	416	[Reset] Discharges the safety measures of the unit	3113
DGT	2	O_Sp_Reset	95	output	416		
DGT	3	I_Sp_Unoc	95	input	417	[BMS] Activation of the Inoccupation mode [Off] occupation mode - [On] inoccupation mode	3925
DGT	3	O_Sp_Unoc	95	output	417		
DGT	17	O_Od_Alarm	95	output	431	[Alarm] General	1000
DGT	18	O_Od_Pump_1	95	output	432	[On/Off] Pump, 1	2615
DGT	19	O_Od_Pump_2	95	output	433	[On/Off] Pump, 2	2616
DGT	20	O_Od_Comp_11	95	output	434	[On/Off] Compressor 1, Circuit 1	2316
DGT	21	O_Od_Comp_21	95	output	435	[On/Off] Compressor 2, Circuit 1	2326
DGT	22	O_Od_Comp_13	95	output	436	[On/Off] Compressor 3, Circuit 1	2336
DGT	23	O_Od_CompHPump_1	95	output	437	[On/Off] Compressor, Heat pump, Circuit 1	2317
DGT	24	O_Od_Comp_12	95	output	438	[On/Off] Compressor 1, Circuit 2	2346
DGT	25	O_Od_Comp_22	95	output	439	[On/Off] Compressor 2, Circuit 2	2356
DGT	26	O_Od_Comp_23	95	output	440	[On/Off] Compressor 3, Circuit 2	2366
DGT	27	O_Od_CompHPump_2	95	output	441	[On/Off] Compressor, Heat pump, Circuit 2	2347
DGT	28	<i>not used</i>	95	output	442	<i>not used</i>	
DGT	29	<i>not used</i>	95	output	443	<i>not used</i>	
DGT	30	<i>not used</i>	95	output	444	<i>not used</i>	
DGT	31	<i>not used</i>	95	output	445	<i>not used</i>	

ANALOGIC DATA

Type	BM50 Index	Name NV	Type NV	Direction	Index	Description	DS50
ANL	1	I_Sp_WCool_1_BMS	105	input	1	[Occupation][Water SP] Required water temperature in °C Cooling set point	3321 BMS
ANL	1	O_Sp_WCool_1_BMS	105	output	1		
ANL	2	I_Sp_WHeat_1_BMS	105	input	2	[Occupation][Water SP] Required water temperature in °C Heating set point	3331 BMS
ANL	2	O_Sp_WHeat_1_BMS	105	output	2		
ANL	3	I_Sp_WCool_1_Uno	105	input	3	[Inoccupation][Water SP] Required water temperature in °C Cooling set point	3321 Uno
ANL	3	O_Sp_WCool_1_Uno	105	output	3		
ANL	4	I_Sp_WHeat_1_Uno	105	input	4	[Inoccupation][Water SP] Required water temperature in °C Heating set point	3331 Uno
ANL	4	O_Sp_WHeat_1_Uno	105	output	4		
ANL	17	O_la_TEEG	105	output	17	[Temperature] Inlet, Water	2112
ANL	18	O_T_Outside	105	output	18	[Temperature] Outdoor, Air	2111
ANL	19	O_la_TSEG	105	output	19	[Temperature] Outlet, Water	2113
ANL	20	O_la_P_HP_1	105	output	20	[Pressure] High, Circuit 1 (Bar)	2125
ANL	21	O_la_P_BP_1	105	output	21	[Pressure] Low, Circuit 1 (Bar)	2126
ANL	22	O_la_P_HP_2	105	output	22	[Pressure] High, Circuit 2 (Bar)	2135
ANL	23	O_la_P_BP_2	105	output	23	[Pressure] Low, Circuit 2 (Bar)	2136
ANL	24	<i>not used</i>	105	output	24	<i>not used</i>	
ANL	25	<i>not used</i>	105	output	25	<i>not used</i>	
ANL	26	<i>not used</i>	105	output	26	<i>not used</i>	
ANL	27	<i>not used</i>	105	output	27	<i>not used</i>	

INTEGER DATA

Type	Index	Name NV	Type NV	Direction	Index	Description	DS50
INT	1	I_Sp_BMS_Dog	8	input	208	[BMS] Activation of the control by a computer or an automat - mode BMS is activated if this value is different from zero, This value is decreased every second	3934
INT	1	O_Sp_BMS_Dog	8	output	208		
INT	2	I_Sp_RunUnit_BMS	8	input	209	[Unit] without pump: 0=Started; 1=Stopped [Unit] with pump: 1=Stopped; 2:P1 Only; 3=P2 Only; 4=P1-N P2-S; 5=P2-N P1-S; 6=P1/P2 by clock	3711 (BMS)
INT	2	O_Sp_RunUnit_BMS	8	output	209		
INT	3	I_Sp_ChOver_BMS	8	input	210	[Unit] Change-over: 0=Cool. Only; 1=Heat. Only; 2=Auto. Pump; 3=Auto. No Pump	3311 BMS
INT	3	O_Sp_ChOver_BMS	8	output	210		
INT	4	I_Sp_Rotat_BMS	8	input	211	[Unit] Activation of the circuits: 0=C1 Only; 1=C2 Only; 2=C1/C2 by clock	3411 (BMS)
INT	4	O_Sp_Rotat_BMS	8	output	211		
INT	17	O_Error_Codes	8	output	224	[Alarm] Code Error	1000
INT	18	<i>not used</i>	81	output	225	<i>not used</i>	
INT	19	<i>not used</i>	81	output	226	<i>not used</i>	
INT	20	<i>not used</i>	81	output	227	<i>not used</i>	
INT	21	<i>not used</i>	81	output	228	<i>not used</i>	
INT	22	O_Error_Bits_1	8	output	229	[Alarm] bit.0 = Flow switch bit.1 = High Temperature, Outlet bit.2 = Low Temperature, Inlet bit.3 = Low Temperature, Outlet bit.4 = High Temperature, Inlet bit.5 = Pump, 1 bit.6 = Pump, 2 bit.7 = Real Time Clock bit.8 = BE50 bit.9 = <i>not used</i> bit.10 = Probes & Sensors bit.11 = Fans, Condenser, Circuit 1 bit.12 = Fans, Condenser, Circuit 2 bit.13 = Fans, Condenser, Circuit 3 bit.14 = <i>not used</i> bit.15 = <i>not used</i>	
INT	23	O_Error_Bits_2	8	output	230	[Alarm] bit.0 = Compressor, Circuit 1, Electric Protection bit.1 = Compressor, Circuit 1, High Pressure bit.2 = Compressor, Circuit 1, Low Pressure or Freeze protection bit.3 = Compressor, Circuit 2, Electric Protection bit.4 = Compressor, Circuit 2, High Pressure bit.5 = Compressor, Circuit 2, Low Pressure or Freeze protection bit.6 = <i>not used</i> bit.7 = <i>not used</i> bit.8 = <i>not used</i> bit.9 = <i>not used</i> bit.10 = <i>not used</i> bit.11 = <i>not used</i> bit.12 = Compressor, Circuit 1, Electronic Expansion Valve bit.13 = Compressor, Circuit 2, Electronic Expansion Valve bit.14 = <i>not used</i> bit.15 = <i>not used</i>	

001	Flow Rate Water Evaporator
011	Electrical Heater(s)
012	High Outlet Water Temperature
013	Low Inlet Water Temperature
022	Low Outlet Water Temperature
023	High Inlet Water Temperature
040	Pump Flow
041	Pump 1
042	Pump 2
070	Clock card
071	BE50
081	Temperature Probe Water Inlet
083	Temperature Probe Outside
085	Temperature Probe Water Outlet
086	Temperature Probe Water Heat Recovery Inlet
087	Temperature Probe Water Heat Recovery Outlet
092	Circuit 1 Condenser fan
093	Circuit 2 Condenser fan
094	Circuit 3 Condenser fan
108	Correction Power factor
111	Circuit 1 Probe High Pressure
112	Circuit 1 Probe Low Pressure
114	Circuit 1 Compressor(s)
115	Circuit 1 High pressure
117	Circuit 1 Low pressure
118	Circuit 1 Risk of Frosting
121	Circuit 2 Probe High Pressure
122	Circuit 2 Probe Low Pressure
124	Circuit 2 Compressor(s)
125	Circuit 2 High pressure
127	Circuit 2 Low pressure
128	Circuit 2 Risk of Frosting
210	Circuit 1 EEV Driver
211	Circuit 1 EEV Low Superheat Temperature
214	Circuit 1 EEV L.O.P
215	Circuit 1 EEV Valve NOT Closed
216	Circuit 1 EEV Probe Low Pressure or Suction Temperature
217	Circuit 1 EEV Motor
219	Circuit 1 EEV Battery
220	Circuit 2 EEV Driver
221	Circuit 2 EEV Low Superheat Temperature
224	Circuit 2 EEV L.O.P
225	Circuit 2 EEV Valve NOT Closed
226	Circuit 2 EEV Probe Low Pressure or Suction Temperature
227	Circuit 2 EEV Motor
228	Circuit 2 EEV E.E.P.R.O.M



www.lennox europe.com

BELGIUM, LUXEMBOURG
www.lennoxbelgium.com

CZECH REPUBLIC
www.lennox.cz

FRANCE
www.lennoxfrance.com

GERMANY
www.lennoxdeutschland.com

GREAT BRITAIN
www.lennoxuk.com

NETHERLANDS
www.lennoxnederland.com

POLAND
www.lennoxpolska.com

PORTUGAL
www.lennoxportugal.com

RUSSIA
www.lennoxrussia.com

SLOVAKIA
www.lennoxdistribution.com

SPAIN
www.lennoxspain.com

UKRAINE
www.lennoxrussia.com

OTHER COUNTRIES
www.lennoxdistribution.com

Due to Lennox's ongoing commitment to quality, the Specifications, Ratings and Dimensions are subject to change without notice and without incurring liability.

Improper installation, adjustment, alteration, service or maintenance can cause property damage or personal injury.

Installation and service must be performed by a qualified installer and servicing agency.

