



©2000 Lennox Industries Inc.  
Dallas, Texas

## GAS KITS & ACCESSORIES

TP Technical  
Publications  
Litho USA

504,040M  
05/2000  
Supersedes 01/2000

## IGNITION CONTROL REPLACEMENT KIT

### INSTALLATION INSTRUCTIONS FOR IGNITION CONTROL REPLACEMENT KIT 53L75 USED WITH G24M-2T/4T, G24E-2T/4T/6T AND G24MCE-2T/4T/5T FURNACES

#### **⚠ WARNING**

This conversion kit is to be installed by a qualified service technician or other qualified agency according to the manufacturer's instructions and all requirements of the current ANSI Z223.1 installation code in the USA or the current CAN/CGA-B149.1 and -B149.2 installation codes in Canada. If the information in these instructions is not followed exactly, a fire or explosion may result, causing property damage, personal injury or loss of life. The qualified agency performing this work assumes responsibility for this conversion.

#### **⚠ CAUTION**

Electrostatic discharge can affect electronic components. Take precautions during furnace installation and service to protect the furnace's electronic controls. Precautions will help to avoid control exposure to electrostatic discharge by putting the furnace, the control and the technician at the same electrostatic potential. Neutralize electrostatic charge by touching hand and all tools on an unpainted unit surface, such as the gas valve or blower deck, before performing any service procedure.

#### Shipping and Packing list

##### Package 1 of 1 contains:

- 1 - Ignition control (EGC-3ACE) 49L9401
- 1 - Ignition control adapter plate
- 1 - Ignition cable
- 1 - Wiring harness
- 4 - #8-18x1/2 self-drill self-tap screws
- 1 - Wiring schematic sticker - (533,092W for G24M-2T/4T models)
- 1 - Wiring schematic sticker - (533,093W for G24E-2T/4T/6T models)
- 1 - Wiring schematic sticker - (533,355W for G24MCE-2T/4T/5T models)
- 1 - Diagnostic sticker
- 4 - Unused hole stickers
- 1 - Unit conversion sticker

#### Shipping Damage

Check all components for shipping damage. Consult last carrier immediately if damage is found.

#### Application

See table 1 for the application of this ignition control replacement kit.

TABLE 1 - IGNITION CONTROL KIT APPLICATION

KIT-PROVIDED CONTROL	EXISTING CONTROL BEING REPLACED	FURNACE MODELS USING THE EXISTING CONTROL
C. C. Controls* (EGC-3ACE) 49L9401	Ram (3MC5) 33J6201	G24M-2T/4T G24E-2T/4T/6T
	Ram (3MC6) 82J7401	G24MCE-2T/4T/5T

\*Caradon Custom Controls

#### Installation - G24M-2T/4T

#### **⚠ WARNING**

Before installing or servicing unit, be sure ALL power to unit is OFF. More than one disconnect switch may be present. Electrical shock can cause personal injury or death!

- 1 - Set the thermostat to the lowest setting. Shut off gas supply and disconnect electrical power from the unit.
- 2 - Remove access door and turn gas valve knob to OFF.

#### Removal Of 3MC5 Control and Related Wiring

- 1 - Disconnect the ignition cable from the ignitor and control board and discard.
- 2 - Mark and disconnect all wires from control board.
- 3 - Separate the connection of the main wire harness at the control board plug.
- 4 - Remove control board and discard.

#### Installation of EGC-3ACE Control and Related Wiring

(Refer to figures 2 and 4)

- 1 - Cover any unused blower access panel holes with the small blank stickers provided.
- 2 - Secure the adapter plate to the blower access panel exactly as shown in figure 2.
- 3 - Snap-mount the control board to the adapter plate, positioned as shown in figure 2.
- 4 - Reconnect existing wires as follows:
  - a - Reconnect blue wire from circuit breaker to "24VAC HOT" terminal on control board.

- b - Reconnect yellow wire from 24V side of transformer to "GND" terminal on control board.
- c - Reconnect green/yellow wire from transformer mounting screw to "GND" terminal of control board.
- d - Reconnect black wire from "240V" terminal on transformer to "L1" terminal on control board.
- e - Reconnect the white wire from common 240V power supply connection to "L2" terminal on control board.
- f - Reconnect black wire from door switch to "L1" terminal on control board.
- g - Reconnect each thermostat wire to its corresponding terminal on the control board.

5 - Connect provided ignition cable to control board and ignitor.

**IMPORTANT - DO NOT INCLUDE IGNITION LEAD IN ANY GROUP OF BUNDLED WIRES. ROUTE IGNITION LEAD SEPARATELY.**

- 6 - Connect the 15 pin female plug of the adapter wire harness to 15 pin male plug of main unit wire harness.
- 7 - Connect the 9 pin male plug of the adapter wire harness to 9 pin female plug on control board.
- 8 - Connect the wire from pin "2" of 15 pin female plug of adapter wire harness to "L2" terminal of control board.
- 9 - Connect the wire from pin "1" of 15 pin female plug of adapter wire harness to "CMB BL WR" terminal of control board.
- 10 - Connect the wire from pin "12" of 15 pin female plug of adapter wire harness to "FLAME" terminal of control board.
- 11 - Connect the blower heating speed tap to "ACB HEAT" terminal on control board, the low speed tap to "ACB LOW" terminal and the cooling speed tap to "ACB COOL" terminal. See figure 7 for blower speed tap.
- 12 - Remove existing wiring diagram sticker, located on the inside surface of unit access panel, and replace with 533,092W wiring diagram sticker (provided).
- 13 - Remove the diagnostic sticker from blower access panel and replace with LB-84882 (provided).
- 14 - Affix unit conversion sticker (LB-95389) beside existing rating plate located on the inside vestibule area of cabinet.

### Installation - G24E-2T/4T/6T

## WARNING

**Before installing or servicing unit, be sure ALL power to unit is OFF. More than one disconnect switch may be present. Electrical shock can cause personal injury or death!**

- 1 - Set the thermostat to the lowest setting. Shut off gas supply and disconnect electrical power from the unit.
- 2 - Remove access door and turn gas valve knob to **OFF**.

### Removal Of 3MC5 Control and Related Wiring

- 1 - Disconnect the ignition cable from the ignitor and control board and discard.
- 2 - Mark and disconnect all wires from control board.
- 3 - Separate the connection of the main wire harness at the control board plug.
- 4 - Remove control board and discard.

### Installation of EGC-3ACE Control and Related Wiring

(Refer to figures 3 and 5)

- 1 - Cover any unused blower access panel holes with the small blank stickers provided.
- 2 - Secure the adapter plate to the blower access panel exactly as shown in figure 3.
- 3 - Snap-mount the control board to the adapter plate, positioned as shown in figure 3.
- 4 - Reconnect existing wires as follows:
  - a - Reconnect blue wire from circuit breaker to "24VAC HOT" terminal on control board.
  - b - Reconnect yellow wire from 24V side of transformer # 2 to "GND" terminal on control board.
  - c - Reconnect green/yellow wire from transformer # 2 mounting screw to "GND" terminal of control board.
  - d - Reconnect black wire from "240V" terminal on transformer # 1 to "L1" terminal on control board.
  - e - Reconnect the white wire from common terminal on transformer # 1 and common blower terminal to "L2" terminal on control board.
  - f - Reconnect black wire from door switch to "L1" terminal on control board.
  - g - Reconnect thermostat wires to thermostat block on control board as follows:
    - R - Red wire
    - G - Brown wire
    - W - White wire
    - Y - Yellow wire

5 - Connect provided ignition cable to control board and ignitor.

**IMPORTANT - DO NOT INCLUDE IGNITION LEAD IN ANY GROUP OF BUNDLED WIRES. ROUTE IGNITION LEAD SEPARATELY.**

- 6 - Connect the 15 pin female plug of the adapter wire harness to 15 pin male plug of main unit wire harness.
- 7 - Connect the 9 pin male plug of the adapter wire harness to 9 pin female plug on control board.
- 8 - Connect the wire from pin "2" of 15 pin female plug of adapter wire harness to "L2" terminal of control board.
- 9 - Connect the wire from pin "1" of 15 pin female plug of adapter wire harness to "CMB BL WR" terminal of control board.
- 10 - Connect the wire from pin "12" of 15 pin female plug of adapter wire harness to "FLAME" terminal of control board.
- 11 - Connect the blower heating speed tap to "ACB HEAT" terminal on control board, the low speed tap to "ACB LOW" terminal and the cooling speed tap to "ACB COOL" terminal. See figure 8 for blower speed tap.

- 12 - Remove existing wiring diagram sticker, located on the inside surface of unit access panel, and replace with 533,093W wiring diagram sticker (provided).
- 13 - Remove the diagnostic sticker from blower access panel and replace with LB-84882 (provided).
- 14 - Affix unit conversion sticker (LB-95389) beside existing rating plate located on the inside vestibule area of cabinet.

### Installation - G24MCE-2T/4T/5T

## WARNING

**Before installing or servicing unit, be sure ALL power to unit is OFF. More than one disconnect switch may be present. Electrical shock can cause personal injury or death!**

- 1 - Set the thermostat to the lowest setting. Shut off gas supply and disconnect electrical power from the unit.
- 2 - Remove access door and turn gas valve knob to **OFF**.

### Removal Of 3MC6 Control and Related Wiring

- 1 - Disconnect the ignition cable from the ignitor and control board and discard.
- 2 - Mark and disconnect all wires from control board.
- 3 - Separate the connection of the main wire harness at the control board plug.
- 4 - Remove control board and discard.

### Installation of ECG-3ACE Control and Related Wiring

(Refer to figures 2 and 6)

- 1 - Cover any unused blower access panel holes with the small blank stickers provided.
- 2 - Secure the adapter plate to the blower access panel exactly as shown in figure 2.
- 3 - Snap-mount the control board to the adapter plate, positioned as shown in figure 2.
- 4 - Reconnect existing wires as follows:
  - a - Reconnect blue wire from circuit breaker to "24VAC HOT" terminal on control board.
  - b - Reconnect yellow wire from 24V side of transformer to "GND" terminal on control board.
  - c - Reconnect piggyback terminated green/yellow wire from ground bar and gas valve to "GND" terminal of control board.

- d - Reconnect black wire from "240V" terminal on transformer to "L1" terminal on control board.
- e - Reconnect the white wire from common "240V" power supply connection to "L2" terminal on control board.
- f - Reconnect the white wire from common "240V" terminal on the transformer to "L2" terminal on control board.
- g - Reconnect black wire from door switch to "L1" terminal on control board.
- h - Reconnect thermostat wires to thermostat block on the control board as follows:
  - R - Red wire
  - G - Brown wire
  - W - White wire
  - Y - Yellow wire
  - C - Blue wire

- 5 - Connect provided ignition cable to control board and ignitor.

**IMPORTANT - DO NOT INCLUDE IGNITION LEAD IN ANY GROUP OF BUNDLED WIRES. ROUTE IGNITION LEAD SEPARATELY.**

- 6 - Connect the 15 pin female plug of the adapter wire harness to 15 pin male plug of main unit wire harness.
- 7 - Connect the 9 pin male plug of the adapter wire harness to 9 pin female plug on control board.
- 8 - Connect the wire from pin "2" of 15 pin female plug of adapter wire harness to "L2" terminal of control board.
- 9 - Connect the wire from pin "1" of 15 pin female plug of adapter wire harness to "CMB BL WR" terminal of control board.
- 10 - Connect the wire from pin "12" of 15 pin female plug of adapter wire harness to "FLAME" terminal of control board.
- 11 - Connect the blower heating speed tap to "ACB HEAT" terminal on control board, the low speed tap to "ACB LOW" terminal, the cooling speed tap to "ACB COOL" terminal, and the common wire to "L2" terminal. See figure 9 for blower speed tap.
- 12 - Remove existing wiring diagram sticker, located on the inside surface of unit access panel, and replace with 533,092W wiring diagram sticker (provided).
- 13 - Remove the diagnostic sticker from blower access panel and replace with LB-84882 (provided).
- 14 - Affix unit conversion sticker (LB-95389) beside existing rating plate located on the inside vestibule area of cabinet.

## EGC-3ACE Control Board Operation

### EGC-3ACE Integrated Blower and Ignition Control Board

The EGC-3ACE control board controls blower operation and fan off timings, allows for thermostat connections, controls ignition and provides two diagnostic LEDs. To interpret the LEDs, see the diagnostic codes section near the end of these instructions or the diagnostic codes sticker provided in the kit. To check operation sequence refer to the flow charts at the end of this instruction.

## Blower Speed/Timing Adjustments

*Important -Turn electrical power off before making any adjustments.*

### Fan 'On' and 'Off' timings

The fan on time of 45 seconds is not adjustable. Fan off time (time that the blower operates after the heat demand has been satisfied) can be adjusted by moving the jumper on the integrated control board. The unit is shipped with a factory fan off setting of 120 seconds. Fan off time will affect comfort and is adjustable to satisfy individual applications. See figure 1.

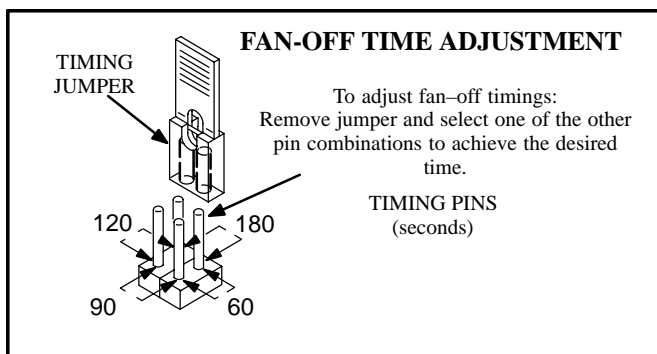

FIGURE 1

## Start-Up

*BEFORE LIGHTING* smell all around the appliance area for gas. Be sure to smell next to the floor because some types of gas are heavier than air and will settle on the floor.

*Use only your hand to move the gas control knob. Never use tools. If the knob will not move by hand, do not try to repair it, call a qualified service technician. Force or attempted repair may result in a fire or explosion.*

### Placing Furnace into Operation

- 1 - Make sure thermostat is set below room temperature and power is turned off to unit.
- 2 - This appliance is equipped with an ignition device which automatically lights the pilot burner. **DO NOT** try to light the pilot burner by hand.
- 3 - Place the gas valve control in the **OFF position**. Do not force.
- 4 - Wait 15 minutes to clear out any gas. If you then smell gas, immediately call your gas supplier from a neighbor's phone. Follow the gas supplier's instructions. If you do not smell gas go to next step.
- 5 - Place the gas valve control in the **ON position**.
- 6 - Turn on all electrical power to unit.
- 7 - Set thermostat to above room temperature.
- 8 - Check gas line supply pressure with unit operating. The minimum pressure as shown on the name rating plate must be available. Then check and adjust manifold pressure to the value indicated on the unit rating plate.
- 9 - Set heat anticipator to 0.65 for Honeywell gas valve and 0.50 for WhiteRodgers gas valve.
- 10 - Run unit through a minimum of three complete cycles to check for normal operation.
- 11 - Set thermostat to desired setting.
- 12 - Replace access panel.

**INSTALLATION OF EGC-3ACE IGNITION CONTROL BOARD  
G24M-2T/4T AND G24MCE-2T/4T/5T MODELS  
(Upflow Orientation Shown)**

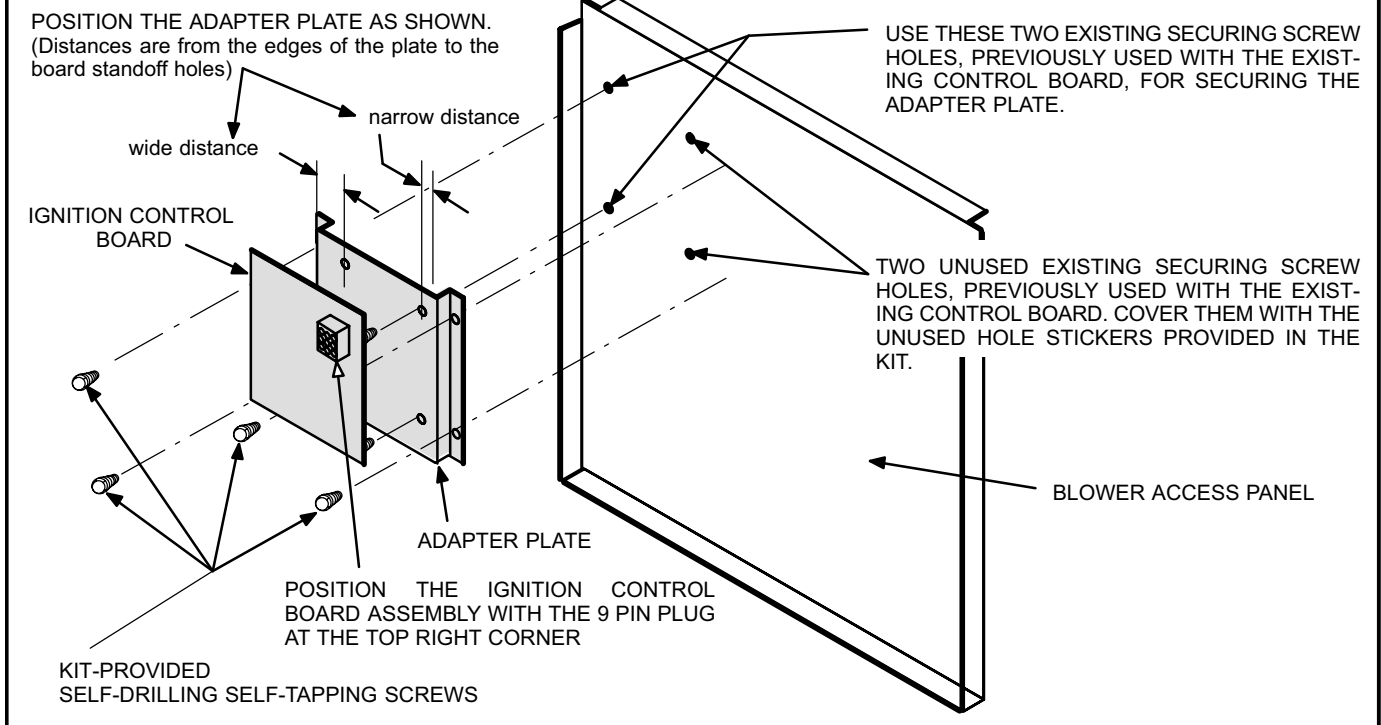

**FIGURE 2**

**INSTALLATION OF EGC-3ACE IGNITION CONTROL BOARD  
G24E-2T/4T/6T MODELS  
(Upflow Orientation Shown)**

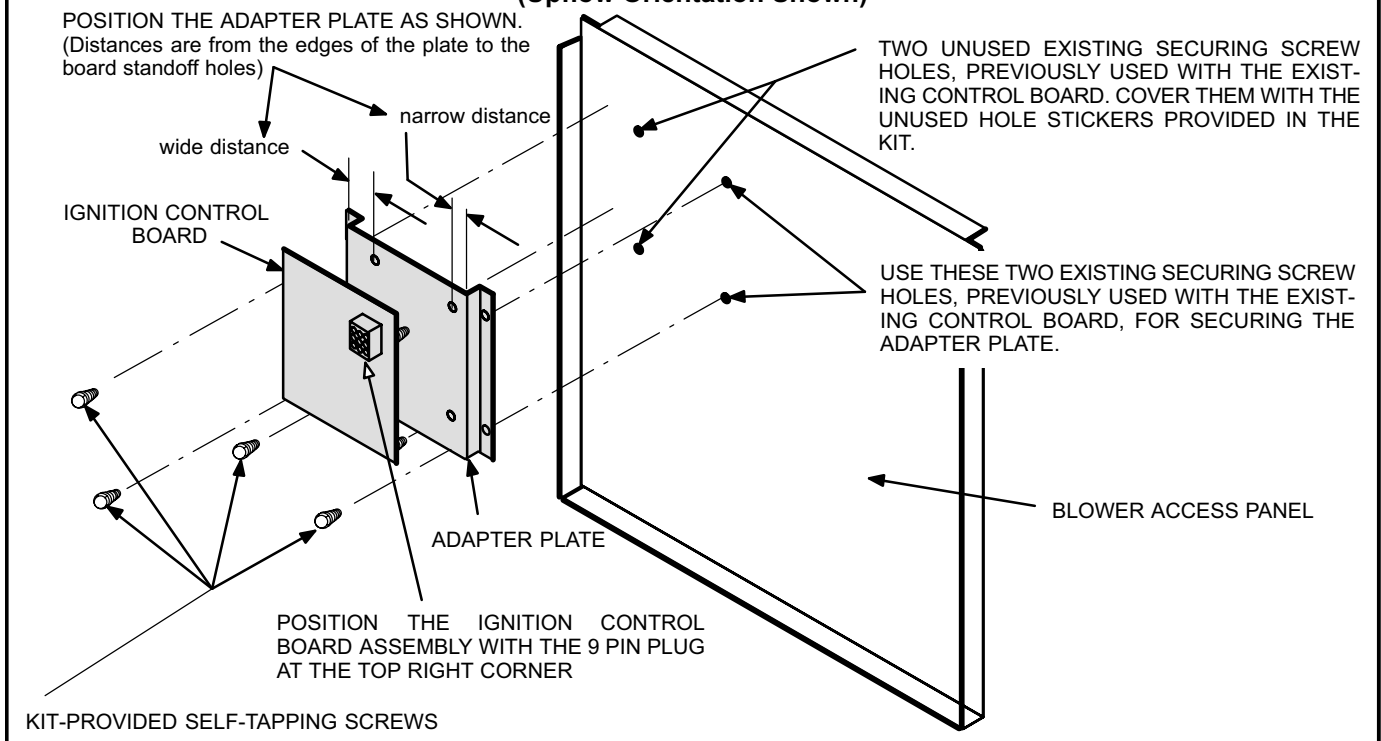

**FIGURE 3**

WIRING DIAGRAM FOR G24M-2T/4T MODELS WITH EGC-3ACE (49L9401) CONTROL BOARD

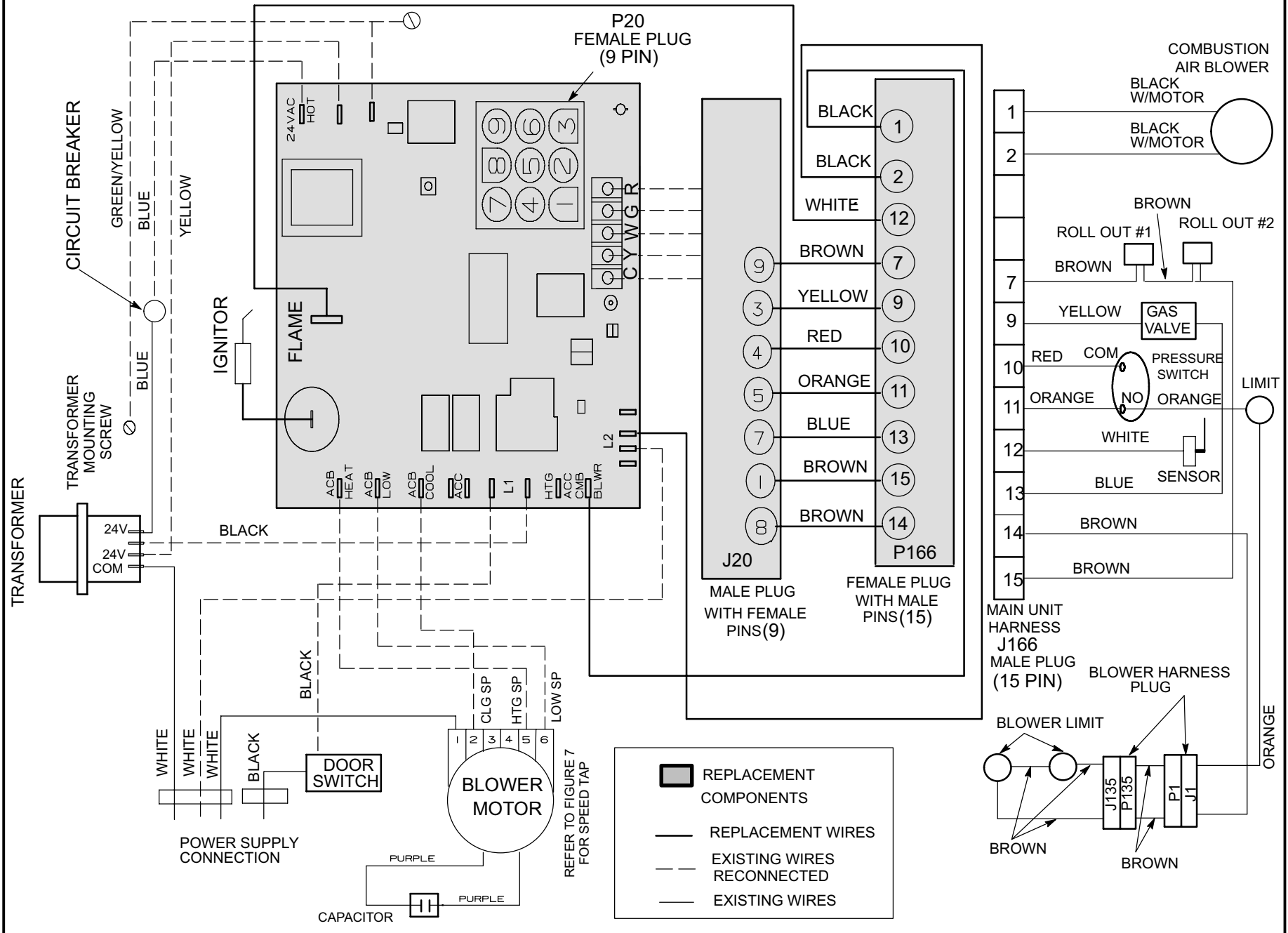
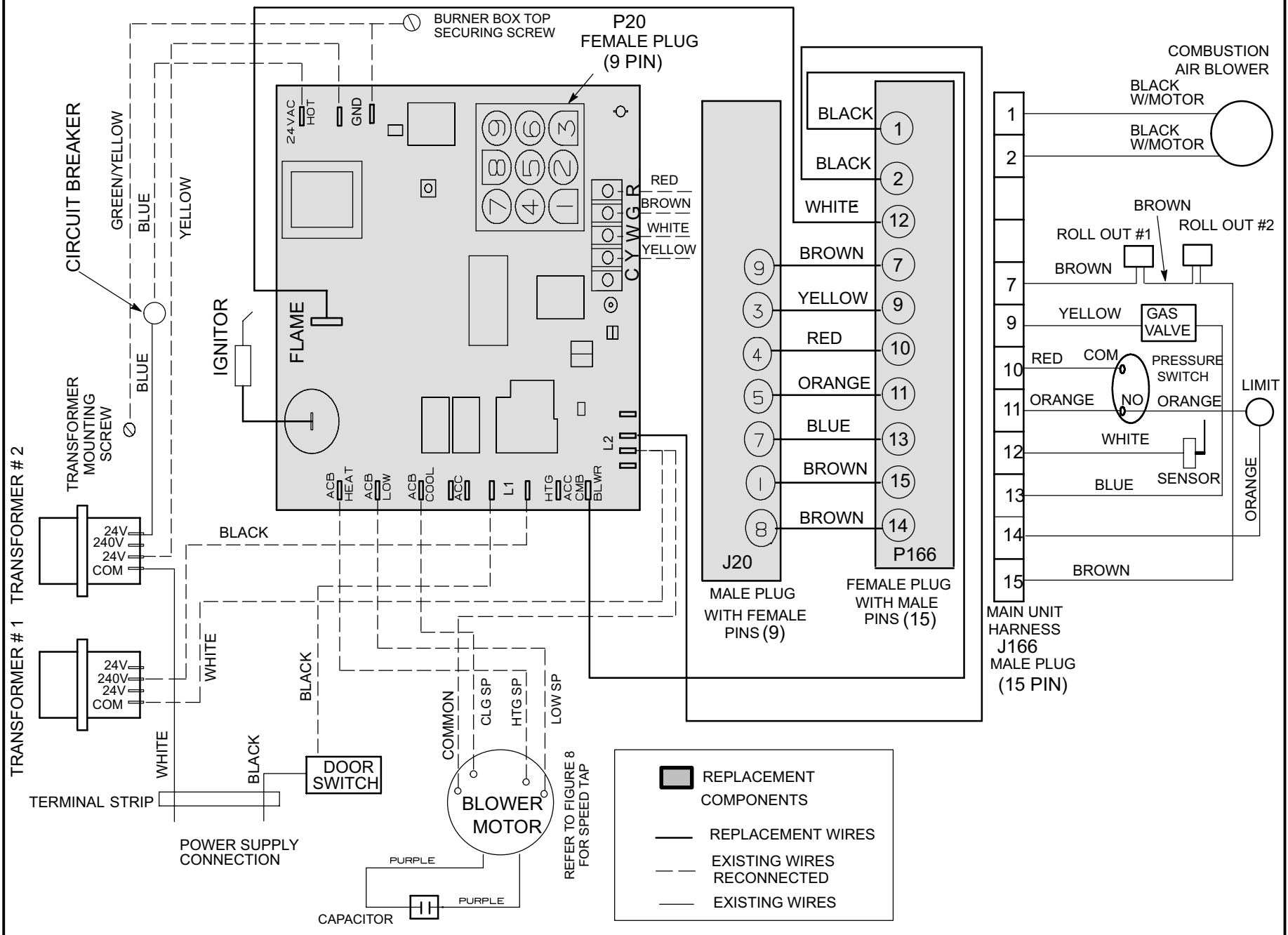

FIGURE 4  
Page 6

**WIRING DIAGRAM FOR G24E-2T/4T/6T MODELS WITH EGC-3ACE (49L9401) CONTROL BOARD**



**FIGURE 5**  
Page 7

WIRING DIAGRAM FOR G24MCE-2T/4T/5T MODELS WITH EGC-3ACE (49L9401) CONTROL BOARD

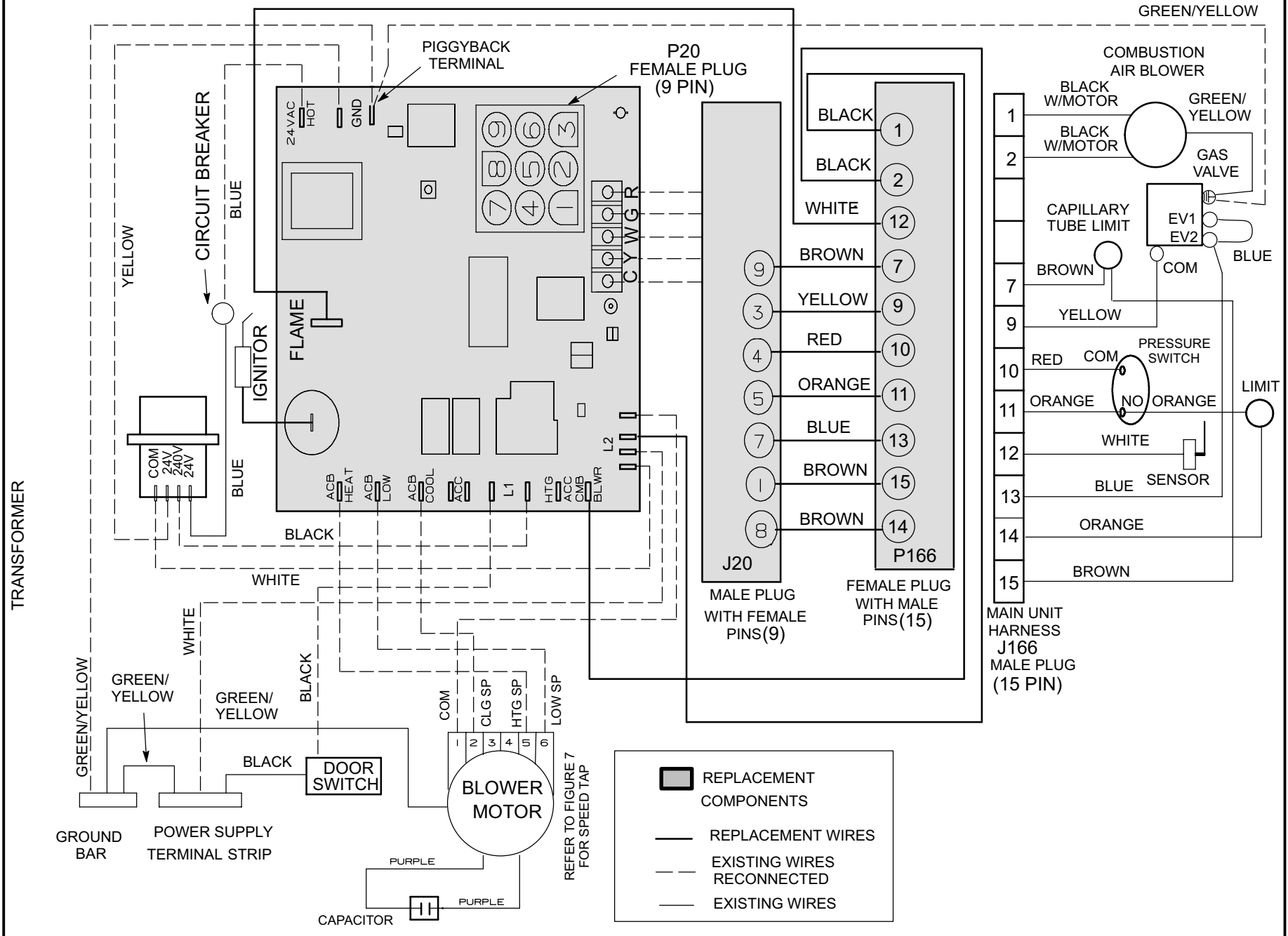
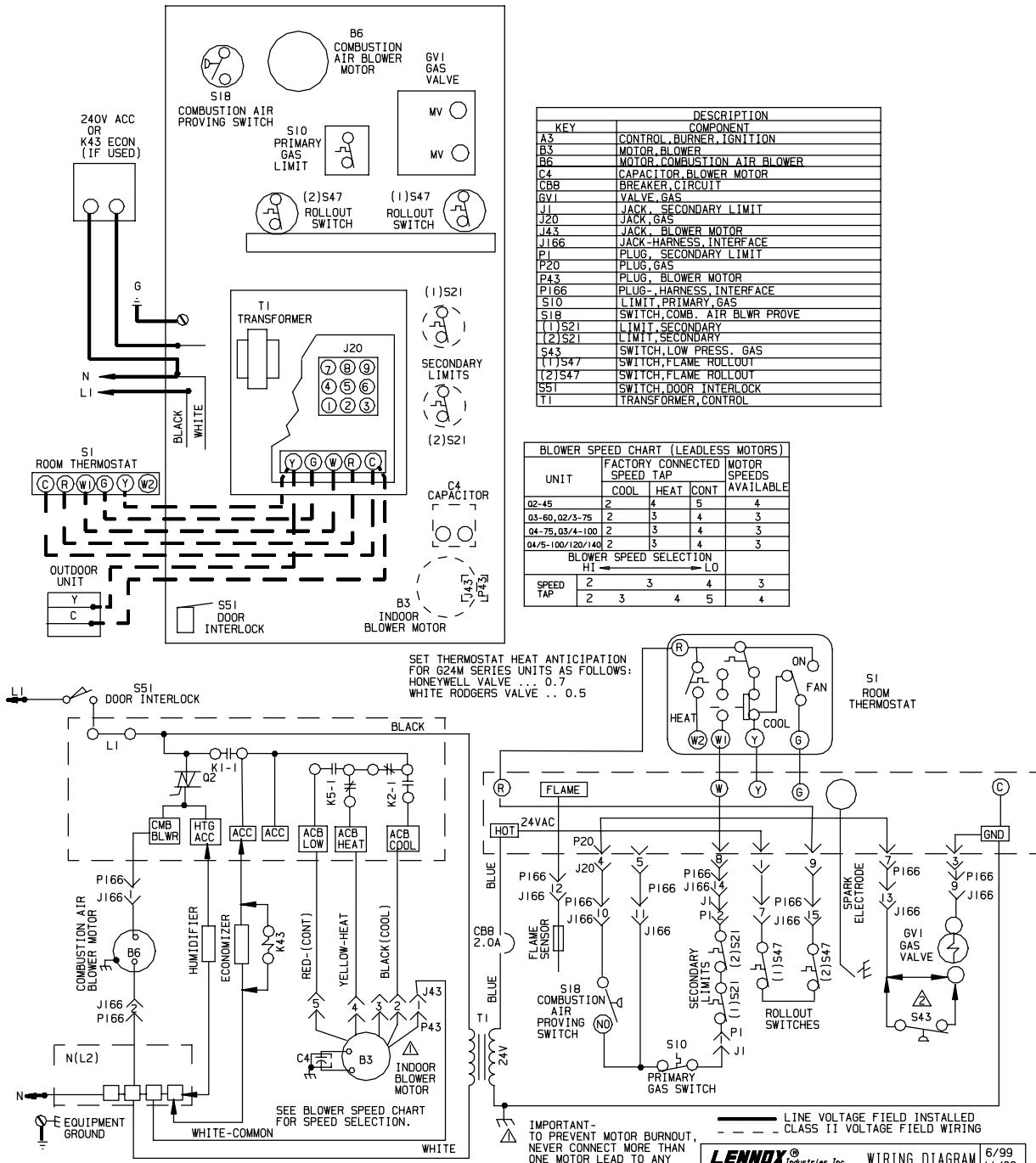

FIGURE 6  
Page 8



# WIRING DIAGRAM FOR G24M-2T/4T UNITS CONVERTED FROM 3MC5 (33J6201) CONTROL BOARD TO EGC-3ACE (49L9401) CONTROL BOARD



KEY	DESCRIPTION
A3	CONTROL, BURNER, IGNITION
B3	MOTOR, BLOWER
B6	MOTOR, COMBUSTION AIR BLOWER
C4	CAPACITOR, BLOWER MOTOR
CBB	BREAKER, CIRCUIT
GVI	VALVE, GAS
J1	JACK, SECONDARY LIMIT
J20	JACK, GAS
J43	JACK, BLOWER MOTOR
J166	JACK-HARNESS, INTERFACE
P1	PLUG, SECONDARY LIMIT
P20	PLUG, GAS
P43	PLUG, BLOWER MOTOR
P166	PLUG-HARNESS, INTERFACE
S10	LIMIT, PRIMARY GAS
S18	SWITCH, COMB. AIR BLWR PROVE
(1)S21	LIMIT, SECONDARY
(2)S21	LIMIT, SECONDARY
S43	SWITCH, LOW PRESS. GAS
(1)S47	SWITCH, FLAME ROLLOUT
(2)S47	SWITCH, FLAME ROLLOUT
S51	SWITCH, DOOR INTERLOCK
T1	TRANSFORMER, CONTROL

UNIT	FACTORY CONNECTED SPEED TAP			MOTOR SPEEDS AVAILABLE
	COOL	HEAT	CONT	
02-45	2	4	5	4
03-60, 02/3-75	2	3	4	3
04-75, 03/4-100	2	3	4	3
04/5-100/120/140	2	3	4	3

BLOWER SPEED SELECTION  
HI ← → LO

SPEED TAP	2	3	4	5	4
	2	3	4	5	4

WARNING-  
ELECTRIC SHOCK HAZARD, CAN CAUSE INJURY  
OR DEATH. UNIT MUST BE GROUNDED IN ACCORDANCE  
WITH NATIONAL AND LOCAL CODES.

NOTE-  
IF ANY WIRE IN THIS APPLIANCE IS REPLACED, IT  
MUST BE REPLACED WITH WIRE OF LIKE SIZE,  
RATING AND INSULATION THICKNESS.

▲ FOR PROPANE/LP ONLY

← DENOTES OPTIONAL COMPONENTS

**LENNOX** Industries Inc. WIRING DIAGRAM 6/99  
11/99

**HEATING UNITS-GAS DSI**

G24M2-45-2T/4T    G24M3/4-100-2T/4T  
G24M3-60-2T/4T    G24M4/5-100/120/140-2T/4T  
G24M2/3-75-2T/4T  
G24M4-75-2T/4T

SECTION A

Supersedes Form No.	New Form No.
	533,092W

©1999 Lennox Industries Inc. Litho U.S.A.

**FIGURE 7**  
Page 9

## WIRING DIAGRAM FOR G24E-2T/4T/6T UNITS CONVERTED FROM 3MC5 (33J6201) CONTROL BOARD TO EGC-3ACE (49L9401) CONTROL BOARD

KEY	DESCRIPTION
	COMPONENT
A3	CONTROL, BURNER, IGNITION
A4	CONTROL INTERFACE
B3	MOTOR, BLOWER
B6	MOTOR, COMBUSTION AIR BLOWER
C3	CAPACITOR, COMB AIR BLOWER
C4	CAPACITOR, BLOWER MOTOR
CB8	CIRCUIT BREAKER
GV1	VALVE, GAS
J20	JACK, GAS
J166	JACK-HARNESS, INTERFACE
P20	PLUG, GAS
P166	PLUG-HARNESS, INTERFACE
S10	LIMIT, PRIMARY, GAS
S18	SWITCH, COMB. AIR BLWR PROVE
S43	SWITCH, LOW PRESS. GAS
(1)S47	SWITCH, FLAME ROLLOUT
(2)S47	SWITCH, FLAME ROLLOUT
S51	SWITCH, DOOR INTERLOCK
T1	TRANSFORMER, CONTROL
T2	TRANSFORMER, CONTROL
TS	TERMINAL STRIP

BLOWER SPEED CHART				
UNIT	FACTORY CONNECTED SPEED TAP			MOTOR SPEEDS AVAILABLE
	COOL	HEAT	CONT	
Q2/3-75	BLACK	YELLOW	RED	4
Q3/4-100	BLACK	YELLOW	RED	3
Q4/5-100	BLACK	YELLOW	RED	3
Q4/5-120	BLACK	YELLOW	RED	3
Q4/5-140	BLACK	YELLOW	RED	3

BLOWER SPEED SELECTION				
SPEED TAP	HI ← → LO			
	(BLACK) HI	(YELLOW) MED	(RED) LOW	
	(BLACK) HI	(BROWN) MED.HI	(YELLOW) (RED) MED.LOW LOW	3
	(BLACK) HI	(BROWN) MED.HI	(YELLOW) (RED) MED.LOW LOW	4

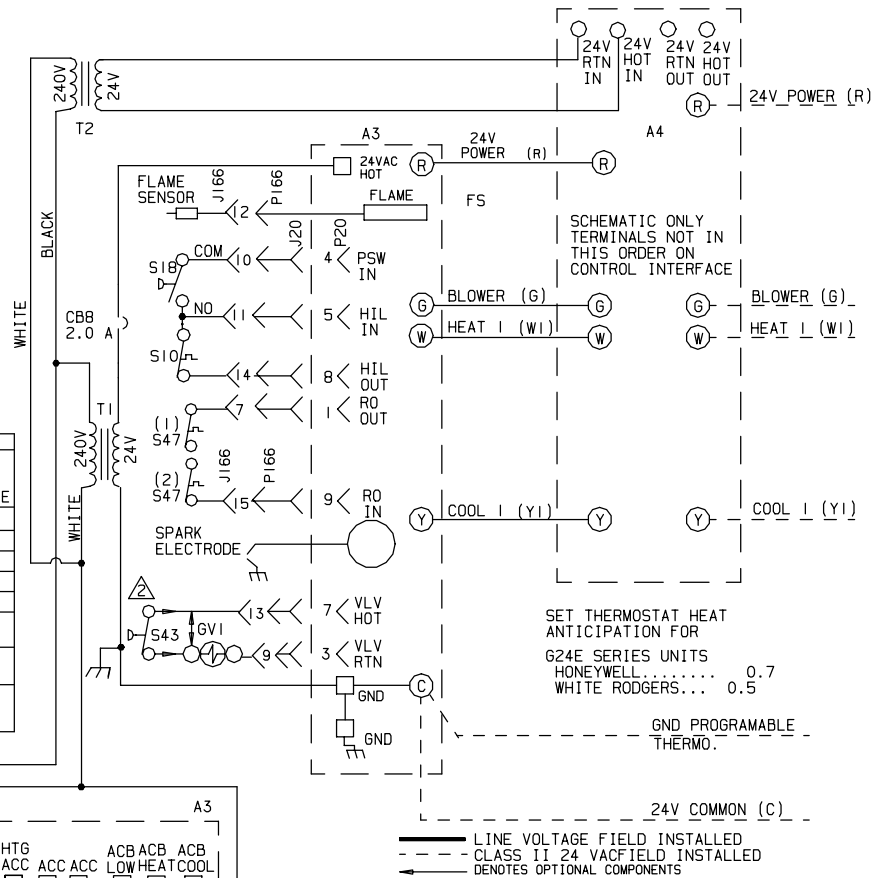
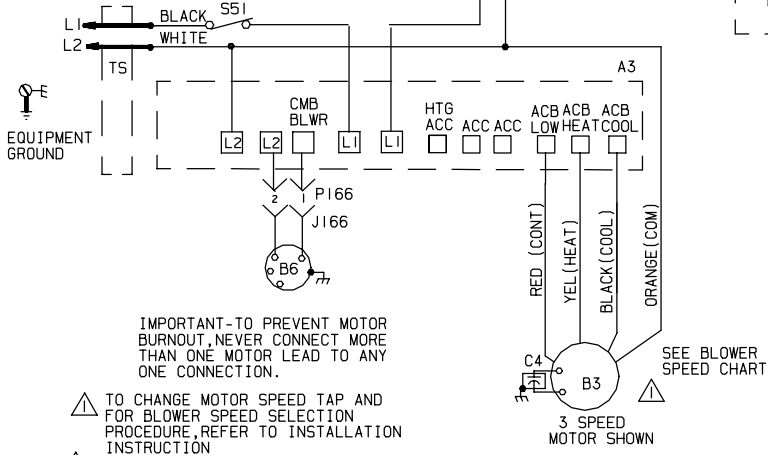

NOTE-  
IF ANY WIRE IN THIS APPLIANCE IS REPLACED, IT MUST BE REPLACED WITH WIRE OF LIKE SIZE, RATING AND INSULATION THICKNESS.

WARNING-  
ELECTRIC SHOCK HAZARD, CAN CAUSE INJURY OR DEATH. UNIT MUST BE GROUNDED IN ACCORDANCE WITH NATIONAL AND LOCAL CODES.

<b>LENNOX</b> Industries Inc		WIRING DIAGRAM	5/99
		HEATING UNITS-GAS DS1	11/99
G24E2/3-75-2T/4T/6T			
G24E3/4-100-2T/4T/6T			
G24E4/5-100/120-2T/4T/6T			
G24E4/5-140-2T/4T/6T			
SECTION A		240/50/1	
Supersedes Form No.	New Form No.		
	533,093W		

© 1999 Lennox Industries Inc. Litho CDN

# WIRING DIAGRAM FOR G24MCE-2T/4T/5T UNITS CONVERTED FROM 3MC6 (82J7401) CONTROL BOARD TO EGC-3ACE (49L9401) CONTROL BOARD

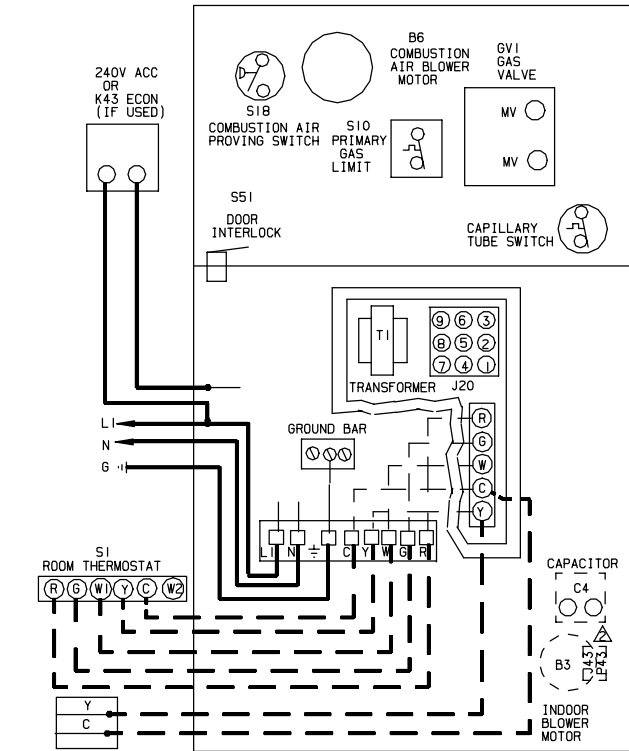

KEY	DESCRIPTION COMPONENT
A3	CONTROL, BURNER, IGNITION
B3	MOTOR, BLOWER
B6	MOTOR, COMBUSTION AIR BLOWER
C4	CAPACITOR, BLOWER MOTOR
CBB	BREAKER, CIRCUIT
GV1	VALVE, GAS
J20	JACK, GAS
J43	JACK-BLOWER MOTOR
J166	JACK-HARNESS, INTERFACE
P20	PLUG, GAS
P43	PLUG-BLOWER MOTOR
P166	PLUG-HARNESS, INTERFACE
S10	LIMIT, PRIMARY GAS
S47	LIMIT, CAPILLARY TUBE
S51	SWITCH, DOOR INTERLOCK
T1	TRANSFORMER, CONTROL
TB1	TERMINAL, BLOCK

UNIT	FACTORY CONNECTED SPEED TAP			MOTOR SPEEDS AVAILABLE
	COOL	HEAT	CONT	
02-45	BLACK	YELLOW	RED	4
03-60	BLACK	YELLOW	RED	3
03-75	BLACK	RED	YELLOW	3
04-75	BLACK	YELLOW	RED	3
04/5-100/120/140	BLACK	YELLOW	RED	3

BLOWER SPEED SELECTION  
HI ← LO

SPEED TAP	(BLACK) (HI)	(YELLOW) (MED)	(RED) (LO)	3
SPEED TAP	(BLACK) (HI)	(BROWN) (MED-HI)	(YELLOW) (RED) (LO)	4

UNIT	FACTORY CONNECTED SPEED TAP				MOTOR SPEEDS AVAILABLE
	COOL	HEAT	CONT		
02-45	2	3	5	4	4
03-60	2	4	4	4	4
03-75	2	4	3	5	5
04-75	2	5	4	5	5
04/5-100/120/140	2	3	4	4	4

BLOWER SPEED SELECTION  
HI ← LO

SPEED TAP	2	3	4	4	
SPEED TAP	2	3	4	5	5

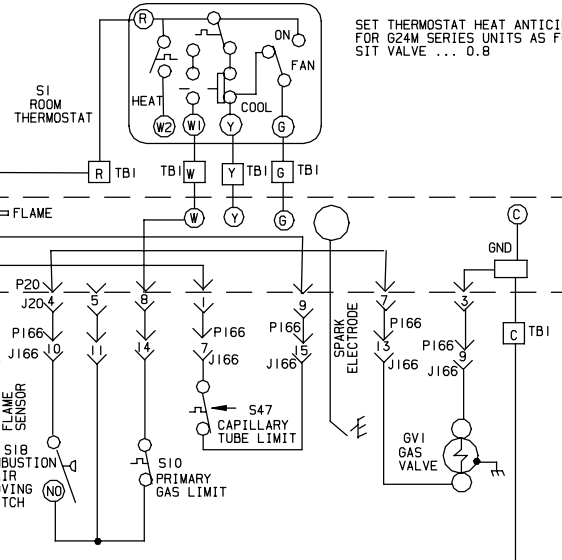
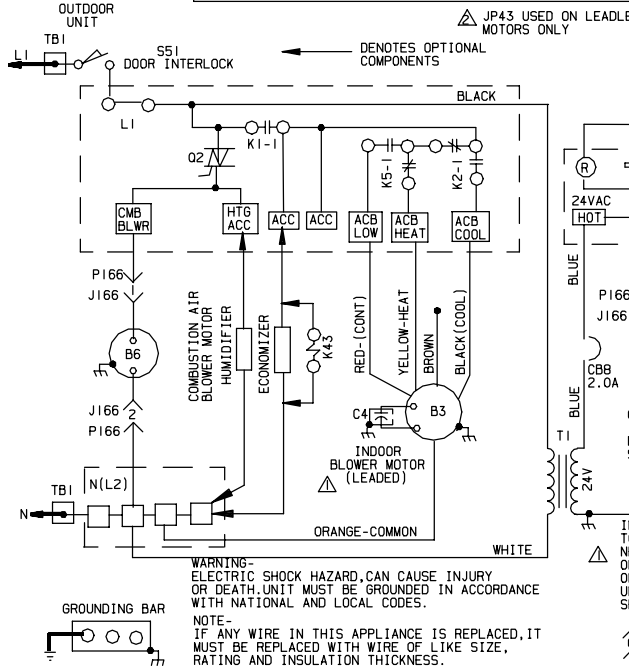

SET THERMOSTAT HEAT ANTICIPATION FOR G24M SERIES UNITS AS FOLLOWS:  
S1T VALVE ... 0.8

IMPORTANT- TO PREVENT MOTOR BURNOUT, NEVER CONNECT MORE THAN ONE MOTOR LEAD TO ANY ONE CONNECTION. TAPE ALL UNUSED MOTOR LEADS SEPARATELY.

— LINE VOLTAGE FIELD INSTALLED  
- - - CLASS 11 VOLTAGE FIELD WIRING

**LENNOX** Industries Inc. WIRING DIAGRAM 11/99

HEATING UNITS-GAS DSI

G24MCE2-45-2T/4T/5T	G24MCE3-75-2T/4T/5T
G24MCE3-60-2T/4T/5T	G24MCE4-75-2T/4T/5T
G24MCE4/5-100/120/140-2T/4T/5T	

SECTION A

Supersedes Form No.	New Form No. <b>533, 355W</b>
---------------------	----------------------------------

© 1999 Lennox Industries Inc. Litho U.S.A.

**FIGURE 9**

# Ignition Control Board Diagnostic Codes

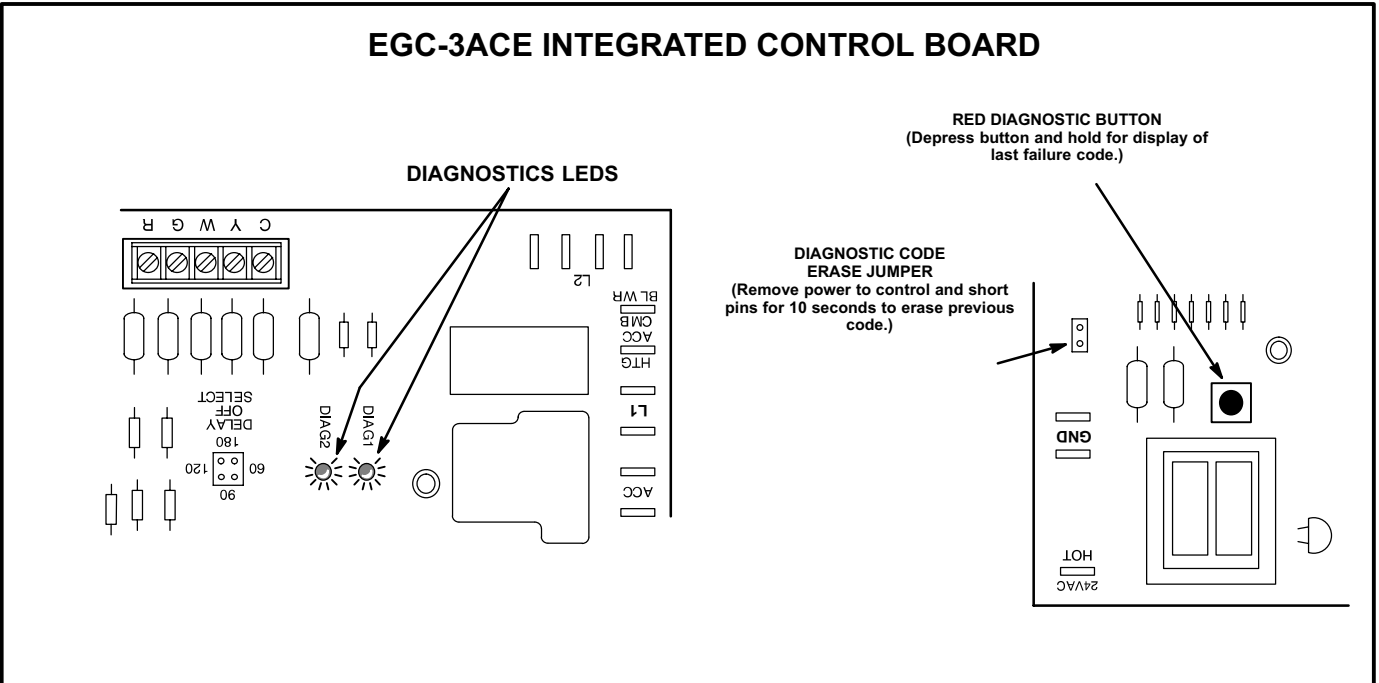

DSI BOARD DIAGNOSTIC PATTERNS	MODE INDICATION	STATUS
<b>DIAG 1</b> <b>Flashing Together</b> <b>DIAG 2</b> <b>Flashing Together</b>	Normal Operation	Slow flashing LED signifies normal operation. Fast flashing LED indicates a heating demand.
<b>DIAG 1</b> <b>Flashing</b> <b>DIAG 2</b> <b>On</b>	Limit Switch Open	This LED pattern indicates that either the primary or secondary limit switch has opened. Both switches are auto-reset. System may be in Watchguard mode.
<b>DIAG 1</b> <b>Off</b> <b>DIAG 2</b> <b>Flashing</b>	Pressure Switch Open	This LED pattern indicates that the pressure switch opened during operation due to reduced flow of combustion products or a blocked condensate drain.
<b>DIAG 1</b> <b>Flashing Alternately</b> <b>DIAG 2</b> <b>Flashing Alternately</b>	Failed Ignition	Burners failed to ignite. The system is in *Hard Lockout mode.
<b>DIAG 1</b> <b>Flashing</b> <b>DIAG 2</b> <b>Off</b>	Flame Failure	This LED pattern indicates that a flame was sensed without power to the gas valve.
<b>DIAG 1</b> <b>On</b> <b>DIAG 2</b> <b>Flashing</b>	Flame Roll-Out/ Capillary Tube Limit Switch Open	This LED pattern indicates that the flame roll-out or capillary tube limit switch has opened. Manually reset switch.
<b>DIAG 1</b> <b>Continuously on</b> <b>DIAG 2</b> <b>Continuously on</b>	Control Board Failure	The system is in *Hard Lockout mode. Run cycle. Check control wiring and replace the control board, if necessary.

**\*Hard Lockout Mode Reset Sequence :** 1 - Turn off the power to the furnace; 2 - Move thermostat control from "HEAT" to "OFF" position; 3 - Turn on the power to the furnace; 4 - Move thermostat control from "OFF" to "HEAT" position.

**HEATING SEQUENCE OF OPERATION**

**NORMAL HEATING MODE**

**ABNORMAL HEATING MODE**

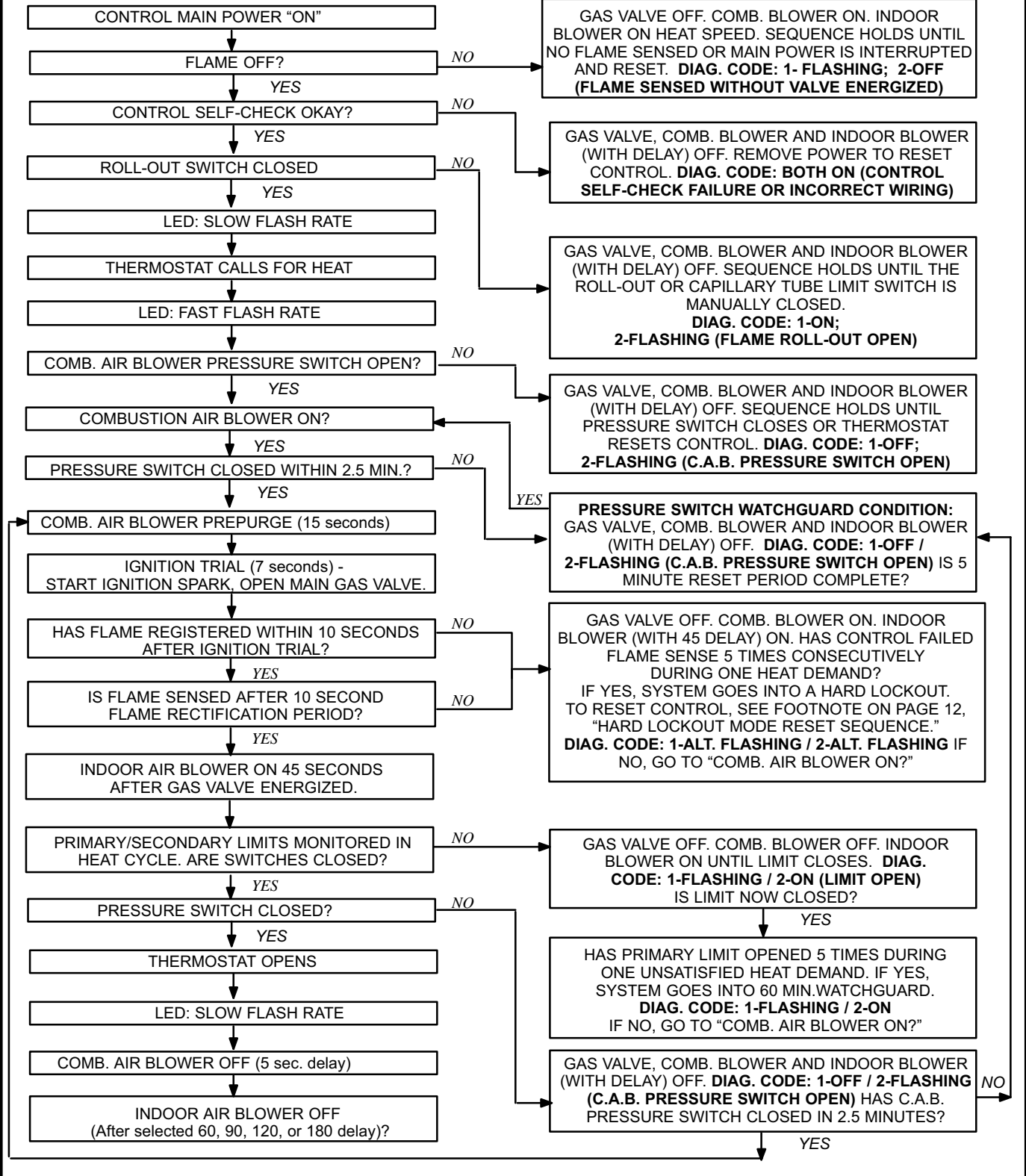

**COOLING SEQUENCE OF OPERATION**

**NORMAL COOLING MODE**

**ABNORMAL COOLING MODE**

