

AS2 Cleaning Device for Cleaning Rotary Heat Exchangers



Page 2

1. Cleaning Options

Page 3

2. Cleaning Device

Page 6

3. Cleaning Sensors

Page 10

4. AS2 Cleaning Control System

Page 16

5. Menu navigation

Page 23

6. Troubleshooting

Page 25

7. Technical Data

1. Cleaning options

Self-cleaning effect

Under the usual conditions for the operation of ventilation systems and air conditioning systems, rotary heat exchangers do not tend to become contaminated. This is due to the laminar airflow in the rotor mass and the counter-current circuitry.

Counterflow Circuit:

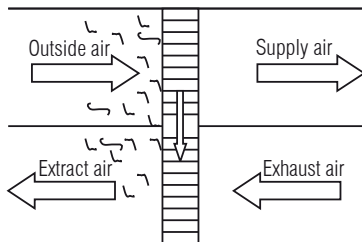

Air filtration before the rotor is only necessary for viscous, greasy and coarse contamination. As the self-cleaning effect occurs only when the rotor is rotating, idle rotors tend to become contaminated.

A cleaning cycle circuit offers a remedy here. The rotor mass is periodically rotated further in order to prevent one-sided accumulation. This cleaning run cycle, also described as interval mode, is integrated in the rotor control system (see control system description for the twist switch – latched controller).

2. Cleaning device

If strongly adhesive contamination is present in the air, the installation of an automatic cleaning apparatus may be sensible. Usually, blowing out with compressed air is sufficient.

Cleaning with high-pressure warm water is necessary only with tenacious viscous and greasy contamination. Please note that the residual water is to be blown out of the rotor following cleaning. For water purification, a compressed air nozzle is therefore always required.

Compressed air cleaning

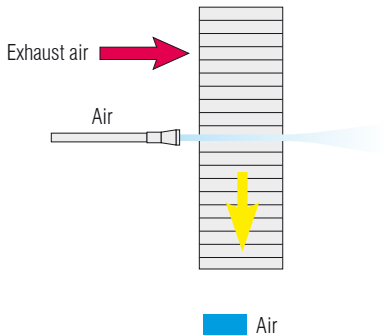

High-pressure warm water cleaning

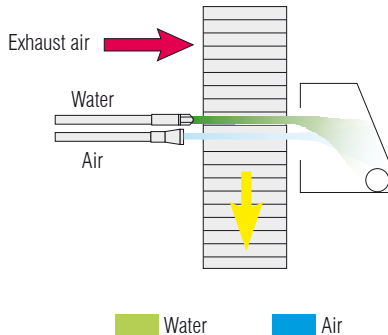

The slide is moved by an AC motor, and the power transmission is through a toothed belt. Contactless proximity switches send an alert when the slide reaches either end position. Another proximity switch is installed in the rotor casing and records the rotor speed.

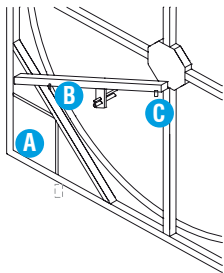

* Sensors are installed on the inside of the cleaning track

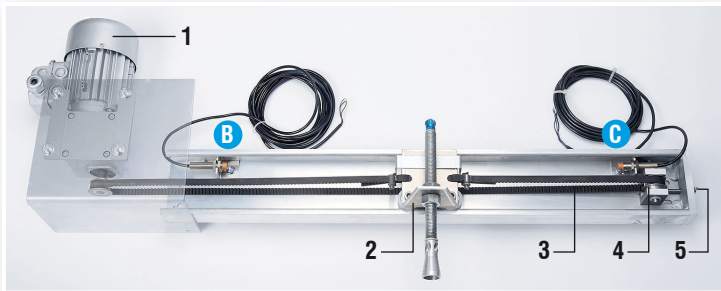

A slide travels on a track over the radius of the rotor. The cleaning nozzles for compressed air and possibly for water, depending on requirements, are installed here.

- A** Pulse sensor (for rotor speed) is located in the rotor casing
- B** Rotor circumference sensor*
- C** Rotor centre sensor*

(1) AS2 drive motor
(2) Nozzle slide

(3) Toothed belt
(4) Idler

(5) Clamping screw

Following each rotation of the rotor, the cleaning apparatus advances by the width of a nozzle stream. This allows gap-free cleaning.

When the cleaning apparatus is switched off, the carriage is positioned on the periphery of the rotor. The cleaning procedure can be started either by a built-in weekly time switch, by an external switch or by the Start switch under the display.

Caution: Ensure that the heat exchanger wheel is released when starting cleaning and is turning for the whole time the program is running. When the cleaning device is operating, the nozzle slide continuously travels to the centre of the rotor. When the sensor reaches the centre, the air and possibly water cleaning begins.

A relay output for warm water and a compressed air valve are available. When the carriage reaches the periphery of the rotor, the water valve relay falls and the rotor is dried with compressed air during the return movement.

On reaching the centre sensor, the air relay switches off and the carriage travels to the starting position. During the cleaning procedure, the rotor runs with variable speed under the control of the AS2 control system.

The external control signal (0 - 10 Volt) is not processed during the cleaning procedure, so this process should be carried out during the idle times.

3. Cleaning Sensors

Manufacturer	Klingenburg
Model	MMG 120BDKX, PNP Switch magnetic
IP code	IP67
Power supply	10-30 V=
Contact	Magnet
Sensing distance	< = 30 mm
Connect. wire colours	blue / brown / black
Usage	Rotors Sorption wheel, Pulse sensor cleaning device

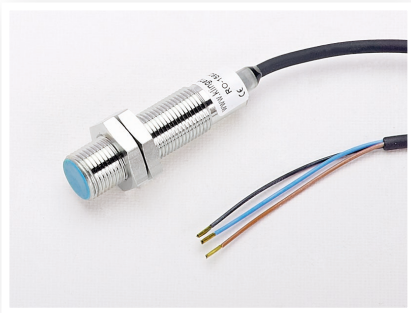

Klingenburg Secatec

Connection to controller:

KR4/7	Clamp 4 = blue; Clamp 5 = brown; Clamp 6 = black
KR15 and Premium	Clamp 6 = blue; Clamp 7 = brown; Clamp 8 = black
KS 4/7/15	Clamp 4 = blue; Clamp 5 = brown; Clamp 6 = black
to cleaning device	+Ub = brown
AS2	Sensor Pulse Tkt = black GND = blue



Steute

Manufacturer	Steute
Model	EEX-RC-M 14W Chanceover contact Reed contact
IP code	IP67 Atex
Power supply	changeover contact up to 250V AC/DC
Contact	Magnet
Sensing distance	≤ 7 mm
Connect. wire colours	gr-yel / grey / brown / black
Usage	Rotor, End position switch slide, pulse sensor cleaning device

Connection to controller:

KR4/7	Clamp 5 = brown; Clamp 6 = black
KR15, Premium	Clamp 7 = brown; Clamp 8 = black
KS 4/7/15	Clamp 5 = brown; Clamp 6 = black
to cleaning device AS2	+Ub = brown; Sensor centre Mit = black Sensor circumference = black Sensor pulse Tkt = black

Manufacturer	Schmersal
Model	IFL-N4-12-10P PNP N/O Inductively
IP code	IP67
Power supply	10-30 Volt =
Contact	Steel contact tabs
Sensing distance	< = 3 mm
Connect. wire colours	blue / brown / black
Usage	Cleaning device standard

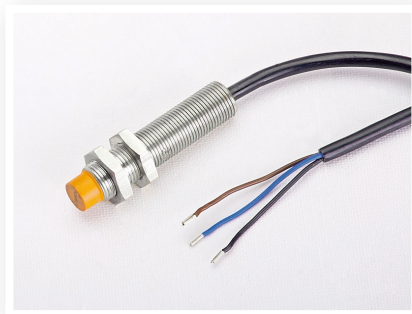

Schmersal

Connection to controller

KR4/7	clamp 4 = blue; clamp 5 = brown; clamp 6 = black
KR15 and Premium	clamp 6 = blue; clamp 7 = brown; clamp 8 = black
KS 4/7/15	clamp 4 = blue; clamp 5 = brown; clamp 6 = black
to cleaning device AS2	+Ub = brown Sensor centre Mit = black Sensor circumference Umf = black GND = blue

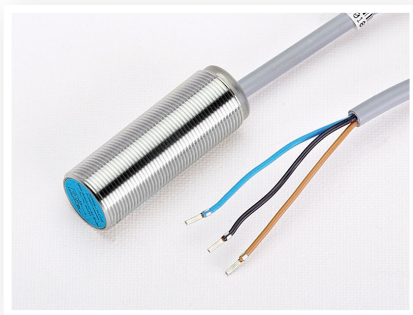

Manufacturer	Pepperl & Fuchs
Model	NBB 8-18GM50-E2-3G-3D PNP N/O Inductively
IP code	IP67Atex
Power supply	10-30 Volt=
Contact	Steel contact tabs
Sensing distance	<=7 mm
Connect. wire colours	blue / brown / black
Usage	ATEX cleaning decice, Rotors

Pepperl & Fuchs

Connection to controller

KR4/7	clamp 4 = blue; clamp 5 = brown; clamp 6 = black
KR 15 and Premium	clamp 6 = blue clamp 7 = brown; clamp 8 = black
KS 4/7/15	clamp 4 = blue; clamp 5 = brown; clamp 6 = black
to cleaning device	+Ub = brown
AS2	sensor centre Mit = black; sensor circumference Umf = black sensor pulse Tkt = black GND = blue

4. AS2 Cleaning Control System

Functional characteristics

- Processor-controlled monitoring of the cleaning sequence
- Coloured display
- Detailed error messages
- Menu navigation
- Cleaning takes place from the inside to the outside
(the contaminated water runs towards the outside)

Functional description

The cleaning control system enables the automatic, electronic cleaning of the contaminated thermal mass of a rotary heat exchanger.

- Standby indicates readiness for operation. A start signal from an external contact, the start button or an optional time switch activates the cleaning procedure.
- Following the start command, the carriage travels without media to the centre of the rotor. When the sensor reaches the centre, the cleaning procedure itself begins and the rotor rotates. **Caution:** The heat exchanger wheel must be released at all times while cleaning.
- The relays switch on the solenoid valves for air and water. Due to the rotation of the rotor, the clock sensor receives the first pulse and the carriage is driven towards the periphery. The carriage should advance by no more than one nozzle width; otherwise, the cleaning will not be so effective.
- This procedure is repeated until the cleaning carriage reaches the periphery of the sensor. The direction of travel then changes and the water relay falls. In order to remove the water from the thermal mass, the cleaning carriage then executes return movement with compressed air.
- On reaching the centre of the sensor, the relay for air switches off and the carriage travels to the park position at the periphery of the rotor. The cleaning procedure is now completed.

Scope of delivery

The standard version of the cleaning device includes the following:

- **Control box for AS 2 cleaning control system, degree of protection IP 54**

(dimensions: see dimension sheet: page 25)

- **Cleaning mechanism for compressed air cleaning**

- Standard guide rail with covering on the inlet side
- Carriage with corresponding nozzle supports
- Pneumatic nozzle, including hose connections
- ca. 5 m pneumatic hose
- 3/2-way pneumatic valve (230 Volt, nominal flow = 9.6 m³/h), including hose connections
- Sensors (three pre-mounted)
- Three-phase motor (400 Volt)

- **Cleaning mechanism with high-pressure hot-water cleaning**

- with high pressure nozzle pipe: 150 - 170 bar at 750 - 900 l/h, external diameter of the nozzle pipe 12 mm with screw threads for connecting attachments
- with high pressure hose, and optional high pressure fittings

- **Cleaning medium collector tray on the output side**

In the inspection window, the display shows the status of the cleaning procedure

S	t	a	n	d	b	y														
P	a	r	k	i	n	g	p	o	s	i	t	i	o	n						

(Selection) (Enter) (Selection)



Reset



Start

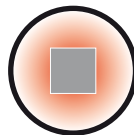

Stop

Button description
for menu navigation

With the three buttons, during commissioning the cleaning procedure can be started, stopped and driven to the start position.

3.4 Connection and commissioning

- The mechanical components (rail, carriage, motor, supports, and sensors) are pre-mounted and must be attached to the frame with screws. The frame is also prepared with rivet-down nuts.
- Adjust the pneumatic nozzles and, if necessary, the high-pressure nozzles so that these end around 20 - 30 mm before the thermal mass.

Attention: The nozzle stream must impinge perpendicular to the thermal mass!

- Control whether the inductive proximity switches are correctly positioned. The metal vanes of the carriage must be positioned around 2 mm away from the sensors. This requires adjusting the clamping block at the end of the rail to loosen the toothed belt. After setting the position switches, position the cleaning carriage in its centre position and tension the toothed belt again. For the correct connection of the centre and peripheral sensors, an LED in the AS 2 control system lights up over the respective terminals on contact.
- Connect the AS 2 control system according to the terminal plan.
- Switch on the mains voltage.
- Adjust the clock sensor on the periphery of the rotor. The clock sensor must receive one pulse per rotor revolution. (sensing distance around 20 mm)
- For commissioning, the cleaning control is equipped with three buttons:
⏪ **Reset** (return to the start position), ▶ **Start** and ◼ **Stop**.

- Start the cleaning procedure with the Start button. The cleaning carriage must continuously drive towards the centre of the rotor. If this is not the case, stop cleaning and reverse the direction of rotation of the motor by switching two phases of the motor.
- When the direction of travel is correct (after changing the direction of rotation, restart the cleaning control), the carriage drives to the centre of the sensor and then begins the actual cleaning process. You can now control the carriage feed. **Per clock signal, the carriage may not travel more than one nozzle width.** In the cleaning control menu, the operating time of the carriage can be set to a value between 0.5 – 2.5 seconds (default setting 1 second).
- After mechanically and electrically controlling the cleaning procedure, execute a so-called **teach-in run** with the **AS 2** control system (see Section 5 Menu navigation on page 16).
- During the **teach-in run** the cleaning carriage travels without media at maximum wheel speed over the entire cleaning procedure and counts the pulses during cleaning and during dry travel and stores these internally with 5% safety margin as limit values.
- This procedure serves for the monitoring of the sensors in normal cleaning operation. In the case of a defect with the sensors, the AS 2 cleaning control system issues an error message due to exceeding the internal limit value, which remains and switches the media off. This prevents the mechanical destruction of the cleaning apparatus and the continued flow of the media.
Attention: When the operating time or the tolerance values are changed in the menu, a teach-in run automatically takes place with the next start of the cleaning procedure.

5. Menu navigation

The operational readiness of the AS2 is indicated by:

S	t	a	n	d	b	y														
P	a	r	k	i	n	g	p	o	s	i	t	i	o	n						

To access the menu hold down the Stop button (■) and press the Reset and the Enter buttons (Ⓢ Ⓜ).

Attention: The cleaning procedure can be stopped and then started again with these buttons. When the carriage is not in the park position or the cleaning procedure is running and someone wants to access the menu, it is necessary to stop the process. One then starts the reset travel and immediately stops it again with the Stop button (■). The display shows:

R	e	s	e	t	t	i	n	g		s	t	o	p						
											b	x	x	x	x				

 →

S	t	a	n	d	b	y													
---	---	---	---	---	---	---	--	--	--	--	--	--	--	--	--	--	--	--	--

Hold down the Stop button **and** press the Reset and Enter buttons (Ⓢ Ⓜ) to return to the menu.

Layout of Menu :

Language → Set Clock → Startingtimes → Calibration → Runtime p. Clock →
R-RPM Linit → Tresholds → Drying Cycles → Limits (Menuend)

Navigate: with the right button (■) right step, with left button (Ⓢ) left step
with the central button (Ⓜ) Enter to access the menu

Holding down the Stop button (■) **and** then pressing the Reset and Enter buttons (⌂ ▶) takes you to the Settings menu

P	r	o	g	.		m	o	d	e						



L	a	n	g	u	a	g	e								

The Enter button (▶) then takes you to the sub-menu.

Language selection:

D	e	u	t	s	c	h									



E	n	g	l	i	s	h									

Confirm the entry with the Enter button (▶) The display then jumps to the next menu item.

Clock setting:

S	e	t		c	l	o	c	k	?						



d	a	y		h	o	u	r		m	i	n				
M	o			1	2				3	3					

The time is only required if start times are to be programmed (see next menu item).

Select using (⌂) and (■). (▶) confirms the entry and the display jumps to the next selection.

Sequence: Week day (Mon, Tue, Wed, Thu, Fri, Sat, Sun) (▶) Hour setting (▶) Minute setting.

Starting times:

S	t	a	r	t	i	n	g	t	i	m	e	s		



		S	t	a	r	t	t	i	m	e		1	:	
		o	f	f										

Up to 7 start times (start time 1: to start time 7) can be selected. Select using and . The day is set in the second line (off / Mon / Tue / Wed / Thu / Fri / Sat / Sun). confirms the entry and the display jumps to the next menu item. If no automatic start is to take place, the start times must be set to “off”.

Calibration:

C	a	l	i	b	r	a	t	i	o	n				

After mechanically and electrically controlling the cleaning procedure, execute the teach-in run!

Pressing takes you to the following setting options:

L	e	a	r	n	i	n	g		m	o	d	e		



		N	o	r	m	a	l		m	o	d	e		

After setting the teach-in run, program the start of the AS2. It is immaterial where the nozzle carriage is positioned, as the initial movement is the reset travel. Following the teach-in run, the AS2 automatically switches to normal operation, followed by:

Confirm the entry with the Enter button The display then jumps to the next menu item.

Runtime:

R	u	n	t	i	m	e		p	.		c	l	o	c	k				



R	u	n	t	i	m	e		p	e	r									
T	a	k	t	i	m	p	u	l	s									1	,5

In this menu item, you can set the travel time for the cleaning carriage. The nozzles should advance by a maximum of 10 mm per clock pulse. The default value is 1.5 seconds. Pressing takes you to:

Speedlimit:

R	-	S	p	e	e	d	l	i	m	i	t								



R	i	n	s	e	S	p	e	e	d	l	i	m	i	t					
																			100%

To improve the cleaning effect, the maximum rotor speed can be restricted in this menu item (100% max. speed).

Caution: If the rotor speed is restricted, the cleaning process will take longer.

R	-	M	i	n	-	L	i	m	i	t									



C	o	i	l	s	p	e	e	d	l	i	m	i	t						
m	i	n	:																30%

For large wheels with long cleaning tracks (>1.5m), due to the variable speed, the rotor only turns very slowly as cleaning progresses, so that cleaning takes a very long time (3-5 hours). This can be avoided by setting a minimum rotor speed limit using this menu item. Adjustment range from 10 - 50% in relation to the control signal in Volts (e.g.: 30 % = 3 Volt control signal. That corresponds to about 3 rpm at normal rotor speeds (10 rpm)).

Press to continue to the tolerance limit setting:

Tolerance limit:

T	o	l	e	r	a	n	c	e		l	i	m	i	t					



T	o	l	e	r	a	n	c	e											
l	i	m	i	t	s	:													

Here, a safety margin is set in % (5, 10 and 20%) for the steps / cycles counted in the learning trip. This is used to compensate for mechanical gear tolerances and to balance out heat technology-related situations (hot / cold).

Caution: The greater the safety margin, the later the switch-off in the event of a fault. With very long cleaning distances (>2m), the 5% setting can lead to premature switch-off. After entering the threshold and confirming it with , you are then taken to the next menu item:

Drying cycles:



This menu item can be used to improve drying, by allowing the cleaning slide to advance only at every 2nd, 3rd or 4th turn of the rotor. This removes as much remaining water from the accumulation as possible.

Caution: Cleaning will take longer with this function.

Thresholds:

T	r	e	s	h	o	l	d	s				H	/	R	
H	:	x	x	x	x					R	:	x	x	x	x

A summary of the thresholds set is once again displayed here.
To complete the parameters, only the values now need to be stored.

		S	t	r	e		d	a	t	a	?			

Press the Enter button () to accept the settings entered.

		D	a	t	a		s	t	r	e	d	!		

Pressing one of the selection buttons rejects the settings. The previous values then remain active.

		N	o	t		s	t	r	e	d	!			

During the cleaning procedure the displays are as follows:
Continuous travel to cleaning position (centre of the rotor)

```
Moving to middle  
sxxxx
```

Cleaning with air and water:

```
Wait f. Trigger  
Cleaning sxxxx
```

bei Takt



```
Running forward  
Cleaning sxxxx
```

Drying with only compressed air:

```
Wait f. Trigger  
Drying sxxxx
```

during pulse





```
Runing backward  
Drying sxxxx
```

Cleaning completed, return to park position

```
Moving to reset!  
          sxxxx
```

The teach-in run is indicated by a large symbol “L” at the lower left. Otherwise, the display is the same as for the cleaning procedure. During the teach-in run, the media are switched off and the rotor rotates at maximum speed.

6. Troubleshooting

The error message can be acknowledged by pressing the three-button combination (  ) under the display. It must then be reset to the start position using the keyboard. Once this has been done, it is ready to start cleaning again. If any one of these errors occurs, the relevant sensors are to be checked

```
Error  
Test circumfsen.
```

```
Error  
Test middlesens.
```

```
Error  
Takt sens. defect?
```

- Has the start-up test run completely?
- Has the rotor stopped during cleaning?

If there is a motor fault, the following appears:

```
Error  
Motortemperatur!
```

- Check motor
- with Atex: ATEX PTC relay has triggered
- without ATEX: Check bridge for thermal protection contact

Cleaning carriage positioned in the centre of the rail:

- Check the step sensor in the rotor (switching distance)
- Rotate the magnet in front of the sensor and measure whether there is 24 Volt DC between the blue and black.
If not, replace the sensor.
- check the timing belt
- Check the rotor regulator:
 - is there a fault?
 - is the regulator released?
 - is the mains voltage present?

In case of power failure:

If the power supply to the AS2 is interrupted while cleaning, an error message is generated when the power is switched back on.

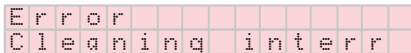

```

Error
Cleaning interr

```

This can be reset in one of two ways:

- The error message is acknowledged by setting the start command again and the cleaning slide automatically resets to the start position. When this has been done, cleaning can be restarted.
- By pressing the 3-button combination (⏪ ⏩ ⏹) under the display. It must then be reset to the start position using the keyboard. Once this has been done, it is ready to start cleaning again.

Caution:

The AS2 has a resettable fuse in the control circuit. It can be reset by briefly disconnecting the AS2 from the power (approx. 1 min.).

7. Technical data

Dimensions of cleaning device AS2

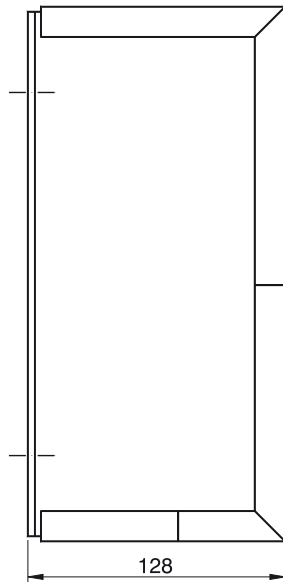
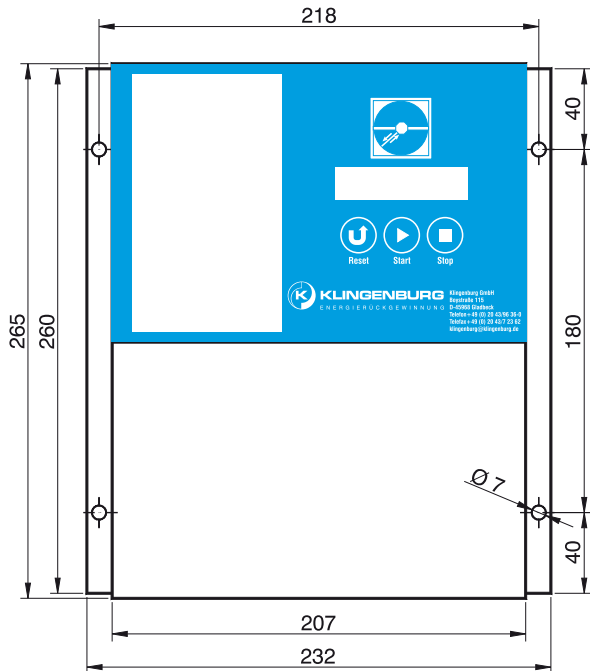

Technical data

Controller type	Cleaning device AS2
Power	0,09 kW
Fuse (external)	min. 4 A
Fuse (internal)	3 x 1A motor / 1 x 0,08 A Control
Mains voltage	380 - 420 Volt 3Ph / N / PE 50-60 Hz
Ambient temperature	-10°C to +40°C
Place of installation	When installing the equipment, ensure that the floor is free of shaking and vibrations
IP code	IP 54
Relay contact	Floating changeover contact, load capacity 250 V AC, 1 A
Weight	3000g
Dimensions	L=265 mm W=232 mm H=128 mm

Maintenance notices (e.g. V-belts re-tensioned on:)

Terminal connection plan for AS 2

****** The PTC contact is already bridged from works (do not remove it). If the equipment will be installed in an ATEX-Area then the motor has to be monitored with a PTC relays.

Please see the connection plan „AS2 with PTC Relays“.

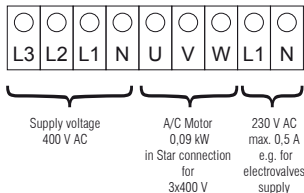
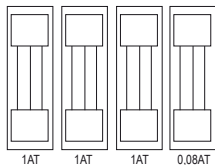

Without ATEX:
do not remove
the bridge
between +Ub
and Tk

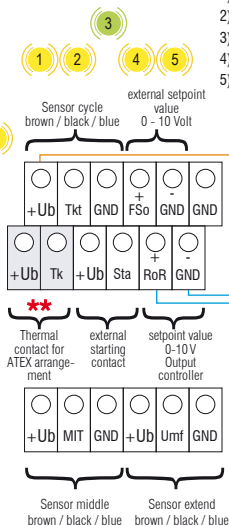

By installation with ex protection from the company STEUTE, only brown and black are to be connected.

- 1) LED yellow: Start
- 2) LED yellow: Sensor middle
- 3) LED green: in Operation
- 4) LED yellow: Sensor Extend
- 5) LED yellow: Sensor Cycle
- 6) LED yellow: Motor thermo safety contact
- 7) LED yellow: Solenoid valve air
- 8) LED yellow: Error
- 9) LED yellow: Status message
- 10) LED yellow: Solenoid valve water

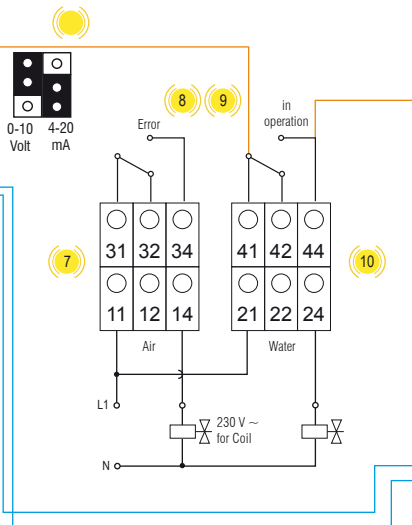

Connection plan Version 2 for control units KR 4/7 Premium (P) and KR 15

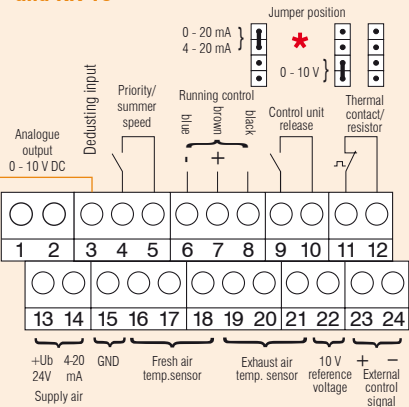

*** AS2 with 4-20mA control signal**
Jumper position in AS2 to the right for mA input
For Rotor control the jumper has to be inserted for 0-10V

Also when the cleaning device is not in operation, the mains voltage of 400V must be present otherwise the control signal will not be switched

Connection plan Version 1 for control unit KR 4/7

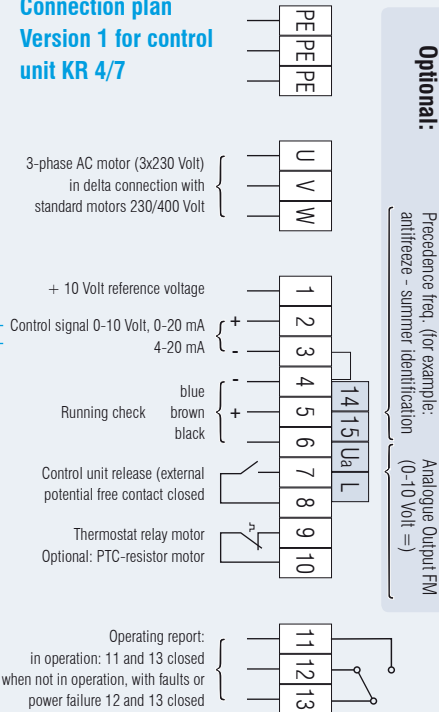

Terminal connection plan for AS 2

Connected to a ATEX-PTC-Relay

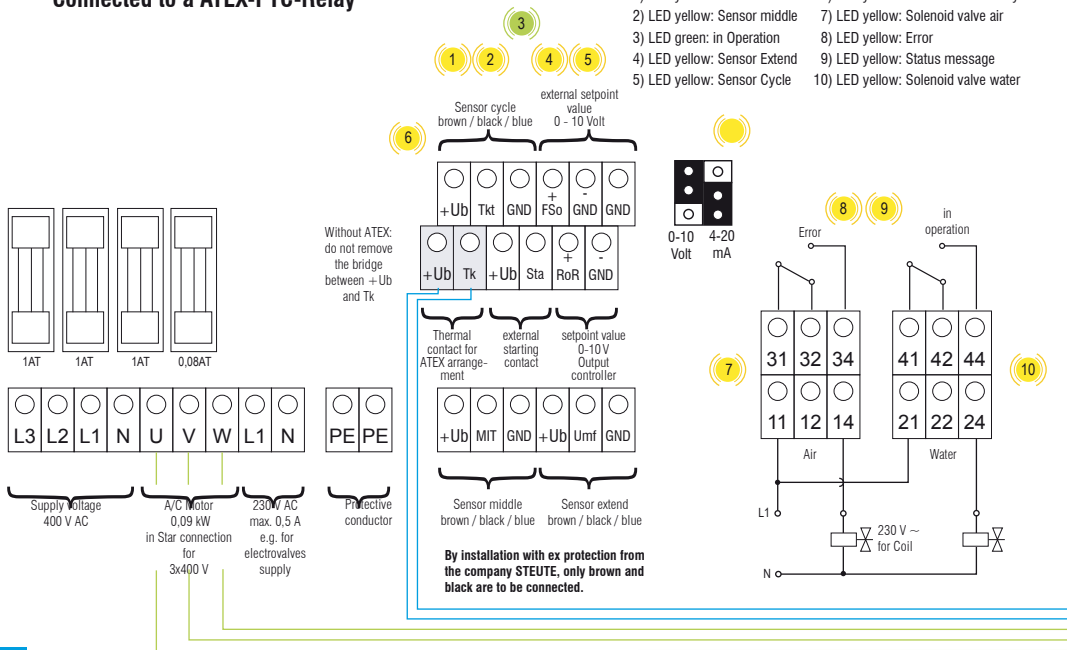

ATEX-PTC-Relay

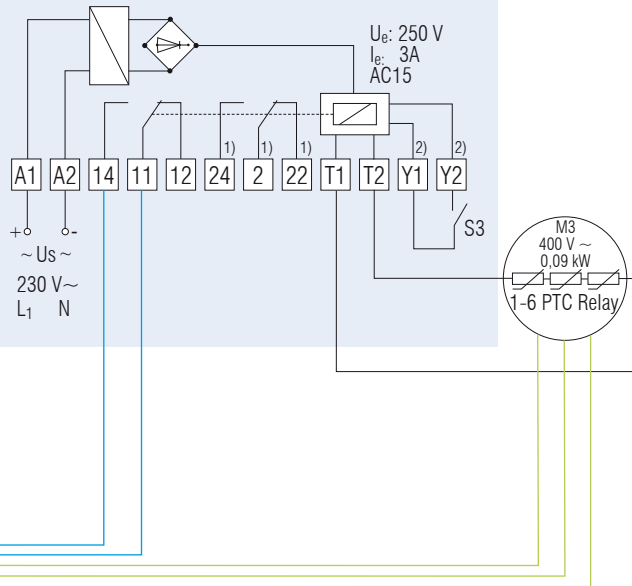

Klingenburg GmbH
Boystraße 115
45968 Gladbeck
Germany

Tel.: +49-20 43-96 36-0

Fax: +49-20 43-7 23 62

E-mail: klingenburg@klingenburg.de

www.klingenburg.de