

HITACHI**PM****NO. 0420E****SERVICE MANUAL**
TECHNICAL INFORMATION**FOR SERVICE PERSONNEL ONLY**

RAD-18NH7A
RAD-25NH7A
RAD-35NH7A
RAD-50NH7A

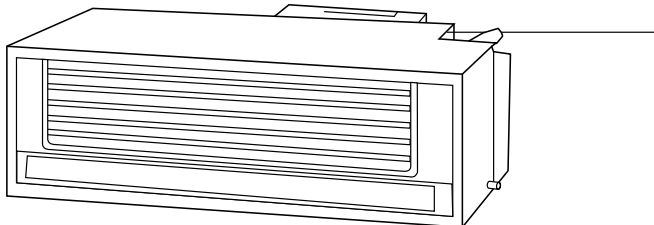
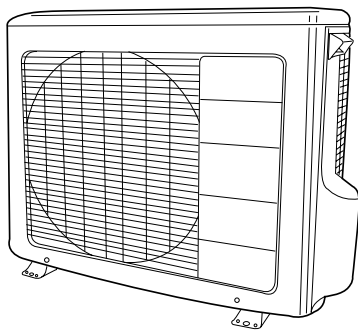

RAC-25NH5
RAC-35NH5
RAC-50NH5

REFER TO THE FOUNDATION MANUAL**CONTENTS**

SPECIFICATIONS	4
HOW TO USE	6
CONSTRUCTION AND DIMENSIONAL DIAGRAM	24
MAIN PARTS COMPONENT	27
WIRING DIAGRAM	29
CIRCUIT DIAGRAM	31
BLOCK DIAGRAM	37
BASIC MODE	39
REFRIGERATING CYCLE DIAGRAM	53
DESCRIPTION OF MAIN CIRCUIT OPERATION	55
SERVICE CALL Q & A	87
TROUBLE SHOOTING	90
PARTS LIST AND DIAGRAM	108

SPECIFICATIONS

TYPE		DC INVERTER (DUCT TYPE)						
		INDOOR UNIT	INDOOR UNIT	OUTDOOR UNIT	INDOOR UNIT	OUTDOOR UNIT	INDOOR UNIT	OUTDOOR UNIT
MODEL		RAD-18NH7A	RAD-25NH7A	RAC-25NH5	RAD-35NH7A	RAC-35NH5	RAD-50NH7A	RAC-50NH5
POWER SOURCE		1 PHASE, 50 Hz, 220-240V	1 PHASE, 50 Hz, 220-240V	1 PHASE, 50 Hz, 220-240V	1 PHASE, 50 Hz, 220-240V	1 PHASE, 50 Hz, 220-240V	1 PHASE, 50 Hz, 220-240V	1 PHASE, 50 Hz, 220-240V
COOLING	TOTAL INPUT (W)	560 (155-850)	695 (155-1,050)	1,240 (155-1,280)	2,000 (155-2,060)			
	TOTAL AMPERES (A)	2.56-2.35	3.20-2.92	5.70-5.24	9.20-8.40			
	CAPACITY	(kW)	1.80 (0.9 ~ 2.5)	2.50 (0.9 ~ 3.0)	3.50 (0.9 ~ 4.0)	5.0 (0.9 ~ 5.6)		
(B.T.U./h)		6,150 (3,070-8,540)	8,540 (3,070-10,240)	11,950 (3,070-13,660)	17,070 (3,070-19,120)			
HEATING	TOTAL INPUT (W)	690 (155-1,050)	970 (155-1,400)	1,700 (155-1,920)	2,300 (155-2,530)			
	TOTAL AMPERES (A)	3.20-2.92	4.50-4.10	7.84-7.19	10.60-9.70			
	CAPACITY	(kW)	2.50 (0.9 ~ 3.2)	3.50 (0.9 ~ 5.0)	4.80 (0.9 ~ 6.6)	6.0 (0.9 ~ 7.5)		
(B.T.U./h)		8,540 (3,070-10,930)	11,950 (3,070-17,070)	16,390 (3,070-22,530)	20,490 (3,070-25,610)			
DIMENSIONS (mm)	W	750	750	750	750	750	850	
	H	235	235	570	235	570	235	650
	D	400	400	280	400	280	400	298
NET WEIGHT (kg)		19	19	38	19	38	19	60

SPECIFICATIONS AND PARTS ARE SUBJECT TO CHANGE FOR IMPROVEMENT**ROOM AIR CONDITIONER****INDOOR UNIT + OUTDOOR UNIT****MAY 2008 Refrigeration & Air-Conditioning Division**

SAFETY DURING REPAIR WORK

1. In order to disassemble and repair the unit in question, be sure to disconnect the power cord plug from the power outlet before starting the work.

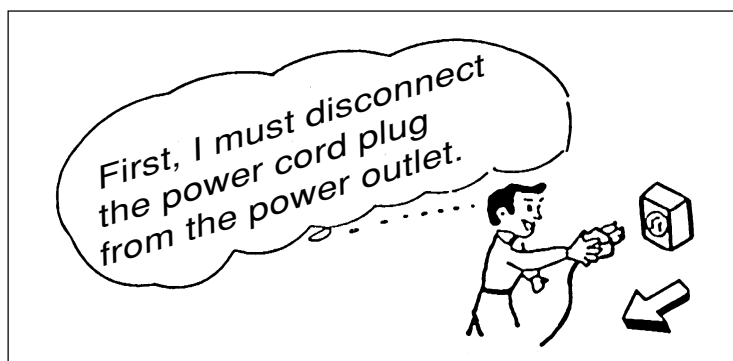

2. If it is necessary to replace any parts, they should be replaced with respective genuine parts for the unit, and the replacement must be effected in correct manner according to the instructions in the Service Manual of the unit.

If the contacts of electrical parts are defective, replace the electrical parts without trying to repair them.

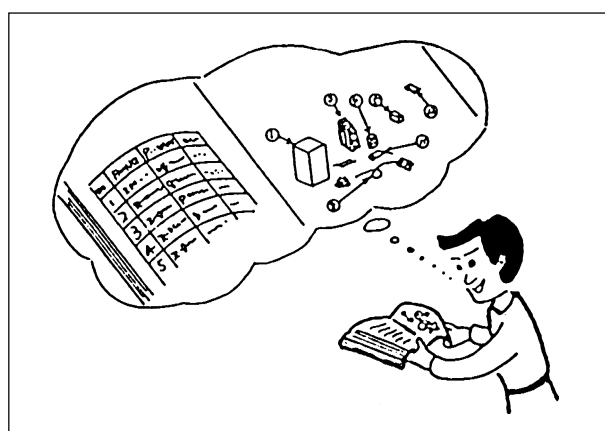

3. After completion of repairs, the initial state should be restored.
4. Lead wires should be connected and laid as in the initial state.
5. Modification of the unit by user himself should absolutely be prohibited.
6. Tools and measuring instruments for use in repairs or inspection should be accurately calibrated in advance.
7. In installing the unit having been repaired, be careful to prevent the occurrence of any accident such as electrical shock, leak of current, or bodily injury due to the drop of any part.
8. To check the insulation of the unit, measure the insulation resistance between the power cord plug and grounding terminal of the unit. The insulation resistance should be $1M\Omega$ or more as measured by a 500V DC megger.
9. The initial location of installation such as window, floor or the other should be checked for being and safe enough to support the repaired unit again. If it is found not so strong and safe, the unit should be installed at the initial location reinforced or at a new location.
10. Any inflammable thing should never be placed about the location of installation.
11. Check the grounding to see whether it is proper or not, and if it is found improper, connect the grounding terminal to the earth.



WORKING STANDARDS FOR PREVENTING BREAKAGE OF SEMICONDUCTORS

1. Scope

The standards provide for items to be generally observed in carrying and handling semiconductors in relative manufacturers during maintenance and handling thereof. (They apply the same to handling of abnormal goods such as rejected goods being returned).

2. Object parts

- (1) Micro computer
- (2) Integrated circuits (IC)
- (3) Field-effect transistors (FET)
- (4) P.C. boards or the like on which the parts mentioned in (1) and (2) of this paragraph are equipped.

3. Items to be observed in handling

- (1) Use a conductive container for carrying and storing of parts. (Even rejected goods should be handled in the same way).

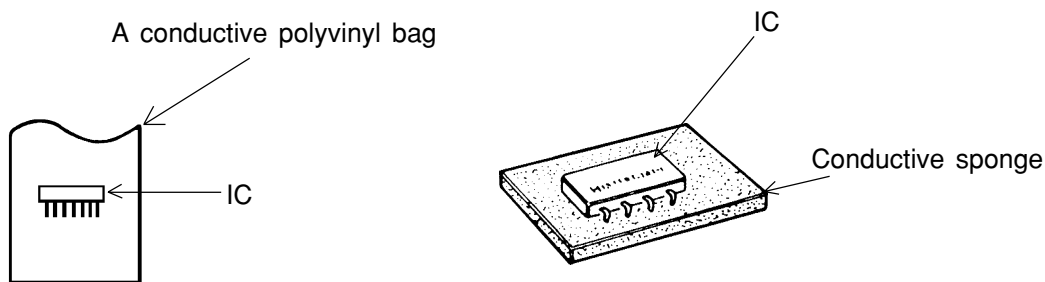

Fig. 1. Conductive Container

- (2) When any part is handled uncovered (in counting, packing and the like), the handling person must always use himself as a body earth. (Make yourself a body earth by passing one M ohm earth resistance through a ring or bracelet).
- (3) Be careful not to touch the parts with your clothing when you hold a part even if a body earth is being taken.
- (4) Be sure to place a part on a metal plate with grounding.
- (5) Be careful not to fail to turn off power when you repair the printed circuit board. At the same time, try to repair the printed circuit board on a grounded metal plate.

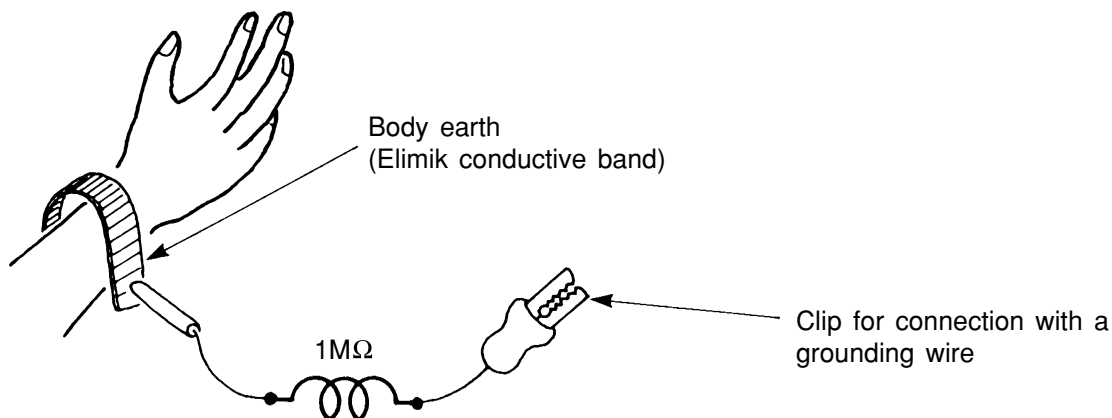

Fig. 2. Body Earth

(6) Use a three wire type soldering iron including a grounding wire.

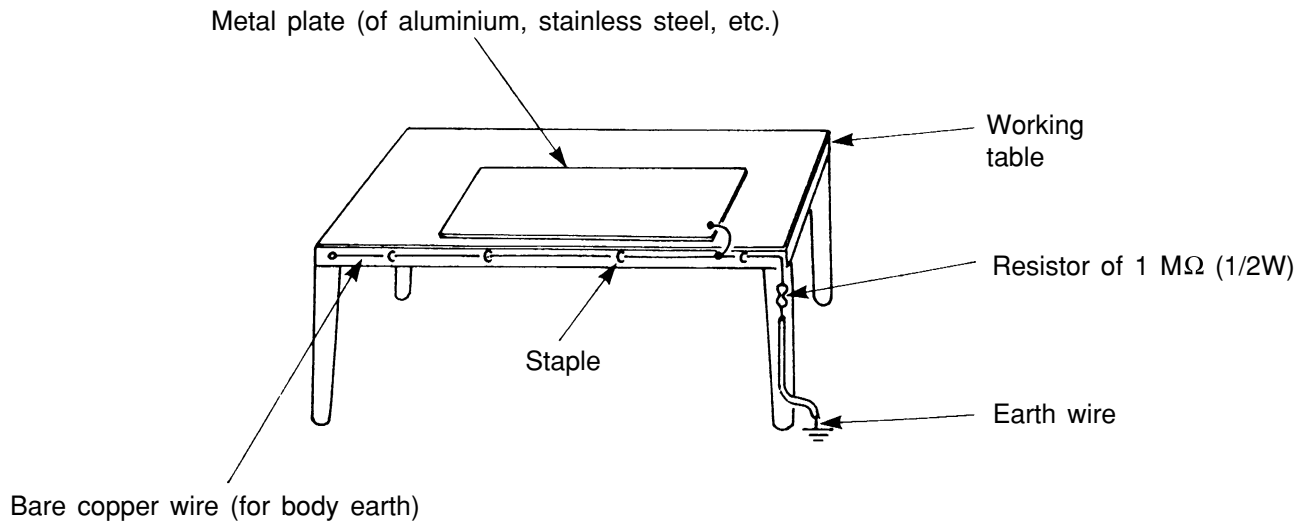

Fig. 3. Grounding of the working table

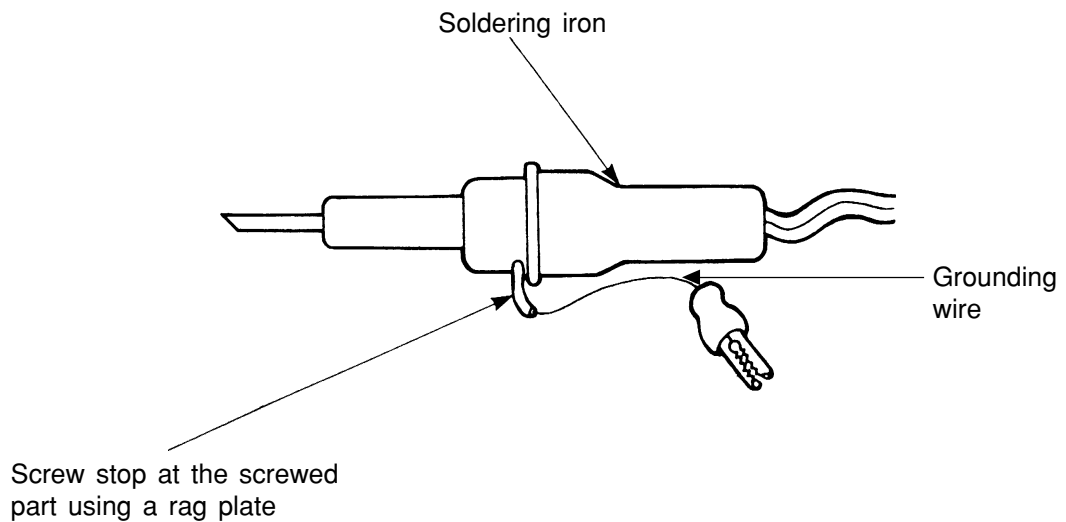

Fig. 4. Grounding a soldering iron

Use a high insulation mode (100V, 10MΩ or higher) when ordinary iron is to be used.

(7) In checking circuits for maintenance, inspection or some others, be careful not to have the test probes of the measuring instrument shortcircuit a load circuit or the like.

 **CAUTION**

1. In quiet operation or stopping the running, slight flowing noise of refrigerant in the refrigerating cycle is heard occasionally, but this noise is not abnormal for the operation.
2. When it thunders near by, it is recommend to stop the operation and to disconnect the power cord plug from the power outlet for safety.
3. The room air conditioner does not start automatically after recovery of the electric power failure for preventing fuse blowing. Re-press START/STOP button after 3 minutes from when unit stopped.
4. If the room air conditioner is stopped by adjusting thermostat, or missoperation, and re-start in a moment, there is occasion that the cooling and heating operation does not start for 3 minutes, it is not abnormal and this is the result of the operation of IC delay circuit. This IC delay circuit ensures that there is no danger of blowing fuse or damaging parts even if operation is restarted accidentally.
5. This room air conditioner should not be used at the cooling operation when the outside temperature is below 10°C (50°F).
6. This room air conditioner (the reverse cycle) should not be used when the outside temperature is below -15°C (5°F).
If the reverse cycle is used under this condition, the outside heat exchanger is frosted and efficiency falls.
7. When the outside heat exchanger is frosted, the frost is melted by operating the hot gas system, it is not trouble that at this time fan stops and the vapour may rise from the outside heat exchanger.

SPECIFICATIONS

MODEL		RAD-18NH7A RAD-25NH7A RAD-35NH7A RAD-50NH7A	RAC-25NH5 RAC-35NH5	RAC-50NH5
FAN MOTOR		20W	40 W	
FAN MOTOR CAPACITOR		NO	NO	
FAN MOTOR PROTECTOR		NO	NO	
COMPRESSOR		–	JU1012D	JU1013D
COMPRESSOR MOTOR CAPACITOR		NO	NO	
OVERLOAD PROTECTOR		NO	YES	
OVERHEAT PROTECTOR		NO	YES	
FUSE (for MICROPROCESSOR)		NO	3.0A	
POWER RELAY		NO	G4A	
POWER SWITCH		NO	NO	
TEMPORARY SWITCH		NO	NO	
SERVICE SWITCH		NO	YES	
TRANSFORMER		NO	NO	
VARISTOR		NO	450NR	
NOISE SUPPRESSOR		NO	YES	
THERMOSTAT		YES(IC)	YES(IC)	
REMOTE CONTROL SWITCH (LIQUID CRYSTAL)		YES	NO	
REFRIGERANT CHARGING VOLUME (Refrigerant 410A)	UNIT	-----	1150g	1400g
	PIPES (MAX. 20m)	WITHOUT REFRIGERANT BECAUSE COUPLING IS FLARE TYPE.		

[Indoor unit installation]

CAUTION

Always install the indoor unit at level. If the indoor unit is inclined, water may leak.

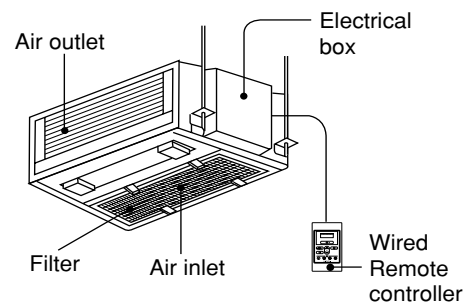
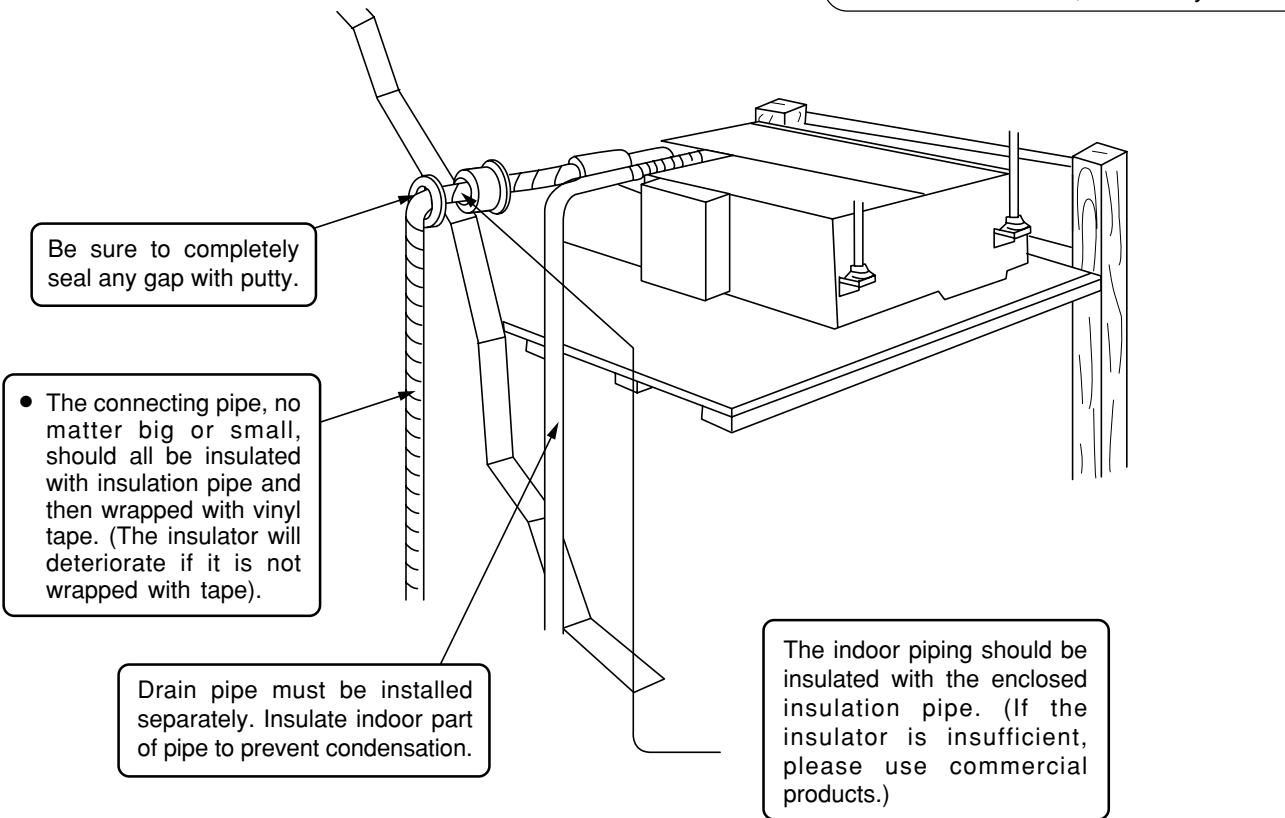



- “Height difference” and “Piping length” of Indoor and Outdoor unit are different by Outdoor unit. Please refer to the installation manual in Outdoor unit.







SAFETY PRECAUTION

- Please read the “Safety Precaution” carefully before operating the unit to ensure correct usage of the unit.
- Pay special attention to signs of “▲ Warning” and “▲ Caution”. The “Warning” section contains matters which, if not observed strictly, may cause death or serious injury. The “Caution” section contains matters which may result in serious consequences if not observed properly. Please observe all instructions strictly to ensure safety.
- The sign indicate the following meanings.



 Make sure to connect earth line.	 The sign in the figure indicates prohibition.
 Indicates the instructions that must be followed.	

- Please keep this manual after reading.





PRECAUTIONS DURING INSTALLATION

 WARNING	<ul style="list-style-type: none"> ● Do not reconstruct the unit. Water leakage, fault, short circuit or fire may occur if you reconstruct the unit by yourself. 	
	<ul style="list-style-type: none"> ● Please ask your sales agent or qualified technician for the installation of your unit. Water leakage, short circuit or fire may occur if you install the unit by yourself. 	
	<ul style="list-style-type: none"> ● Please use earth line. Do not place the earth line near water or gas pipes, lightning-conductor, or the earth line of telephone. Improper installation of earth line may cause electric shock. 	
 CAUTION	<ul style="list-style-type: none"> ● A circuit breaker should be installed depending on the mounting site of the unit. Without a circuit breaker, the danger of electric shock exists. 	
	<ul style="list-style-type: none"> ● Do not install near location where there is flammable gas. The outdoor unit may catch fire if flammable gas leaks around it. 	
	<ul style="list-style-type: none"> ● Please ensure smooth flow of water when installing the drain hose. 	

PRECAUTIONS DURING SHIFTING OR MAINTENANCE

 WARNING	<ul style="list-style-type: none"> ● Should abnormal situation arises (like burning smell), please stop operating the unit and turn off the circuit breaker. Contact your agent. Fault, short circuit or fire may occur if you continue to operate the unit under abnormal situation. 	 
	<ul style="list-style-type: none"> ● Please contact your agent for maintenance. Improper self maintenance may cause electric shock and fire. 	
	<ul style="list-style-type: none"> ● Please contact your agent if you need to remove and reinstall the unit. Electric shock or fire may occur if you remove and reinstall the unit yourself improperly. 	
	<ul style="list-style-type: none"> ● If the supply cord is damaged, it must be replaced by the special cord obtainable at authorized service/parts centers. 	

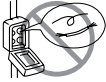
PRECAUTIONS DURING OPERATION

 WARNING	<ul style="list-style-type: none"> ● Avoid an extended period of direct air flow for your health. 	
	<ul style="list-style-type: none"> ● Do not insert a finger, a rod or other objects into the air outlet or inlet. As the fan is rotating at a high speed, it will cause injury. Before cleaning, be sure to stop the operation and turn the breaker OFF. 	
	<ul style="list-style-type: none"> ● Do not use any conductor as fuse wire, this could cause fatal accident. 	
	<ul style="list-style-type: none"> ● During thunder storm, disconnect and turn off the circuit breaker. 	

PRECAUTIONS DURING OPERATION

- The product shall be operated under the manufacturer specification and not for any other intended use.

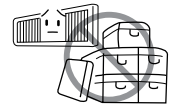

- Do not attempt to operate the unit with wet hands, this could cause fatal accident.

- When operating the unit with burning equipments, regularly ventilate the room to avoid oxygen insufficiency.

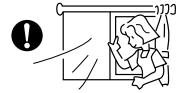

- Do not direct the cool air coming out from the air-conditioner panel to face household heating apparatus as this may affect the working of apparatus such as the electric kettle, oven etc.

- Please ensure that outdoor mounting frame is always stable, firm and without defect. If not, the outdoor unit may collapse and cause danger.



- Do not splash or direct water to the body of the unit when cleaning it as this may cause short circuit.

- Do not use any aerosol or hair sprays near the indoor unit. This chemical can adhere on heat exchanger fin and blocked the evaporation water flow to drain pan. The water will drop on tangential fan and cause water splashing out from indoor unit.



C
A
U
T
I
O
N

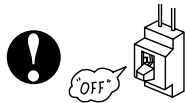

- Please switch off the unit and turn off the circuit breaker during cleaning, the high-speed fan inside the unit may cause danger.

- Turn off the circuit breaker if the unit is not to be operated for a long period.

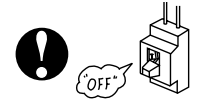

- Do not climb on the outdoor unit or put objects on it.

- Do not put water container (like vase) on the indoor unit to avoid water dripping into the unit. Dripping water will damage the insulator inside the unit and causes short-circuit.

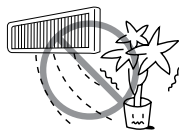

- Do not place plants directly under the air flow as it is bad for the plants.

- When operating the unit with the door and windows opened, (the room humidity is always above 80%) and with the air deflector facing down or moving automatically for a long period of time, water will condense on the air deflector and drips down occasionally. This will wet your furniture. Therefore, do not operate under such condition for a long time.
- If the amount of heat in the room is above the cooling or heating capability of the unit (for example: more people entering the room, using heating equipments and etc.), the preset room temperature cannot be achieved.

- This appliance is not intended for use by young children or infirm persons unless they have been adequately supervised by a responsible person to ensure that they can use the appliance safely.
- Young children should be supervised to ensure that they do not play with the appliance.

MULTI-AIR CONDITIONER

With this multi-air conditioner, several indoor units can be connected to one outdoor unit to be driven. You can operate the required number of indoor units.

Combination of Operations:

When operation mode is selected:

- You cannot operate the indoor units in the following combinations.

One unit	Other unit
Heating	Cooling
	Dehumidifying
	Circulating (fan)

- The indoor unit which is switched on first continues to operate, but other indoor units which is switched on later does not operate while the lamp lights.
- To re-start an indoor unit which was operated later, stop the indoor unit which was operated first or later and reset the type of operation, then perform operation again.

During automatic operation:

- When heating operation is automatically selected for the first indoor unit, the next indoor unit will then start to heat. Also, if cooling or dehumidifying is automatically selected for the first indoor unit, the next indoor unit will also start to cool or dehumidify.

Adjusting the Number of Indoor Units:

Decrease the number of indoor units to be operated especially when it is very hot or cold or when you want to reach the present temperature quickly.

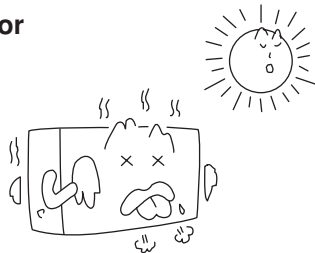

Stopped Indoor Units:

When an indoor unit is operated in the cooling, heating or dehumidifying mode in the room, the sound of refrigerant flow may be heard from a stopped indoor unit or a stopped indoor unit may become warm. This is because the indoor unit returns refrigerant to the outdoor unit to be ready for operation.

NAMES AND FUNCTIONS OF EACH PART

INDOOR UNIT

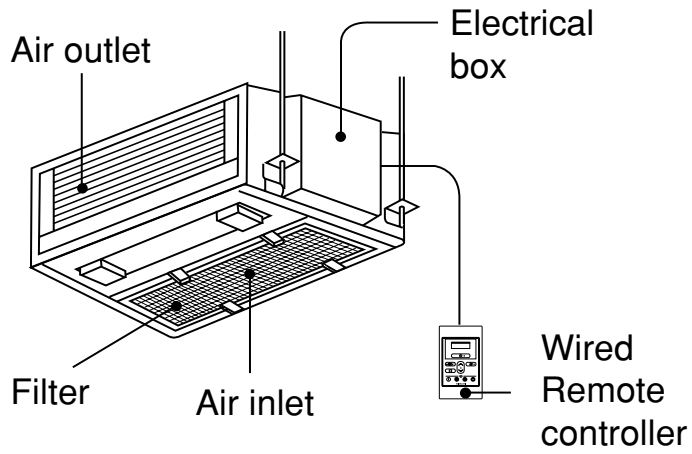

MODEL NAME AND DIMENSIONS

MODEL	WIDTH (mm)	HEIGHT (mm)	DEPTH (mm)
RAD-18NH7A/RAD-25NH7A/RAD-35NH7A/RAD-50NH7A	750	235	400





NAMES AND FUNCTIONS OF REMOTE CONTROL UNIT

■ This controls the operation function and timer setting of the room air conditioner.

START/STOP Button

Press this button to start operation.
Press it again to stop operation.

FUNCTION Button

Use this button to select the operating mode. Every time you press it, the mode will change from  (AUTO) to  (HEAT) to  (DEHUMIDIFY) and to  (COOL) cyclically.

SLEEP Button

Use this button to set the sleep timer. (☞ Page 16)

Reserve Button

Timer setting reservation.

OFF TIMER Button

Select the turn OFF time.

ON TIMER Button

Select the turn ON time.

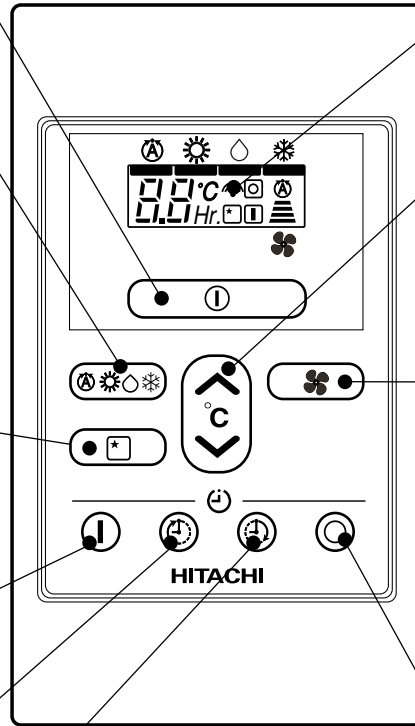





Transmission Sign

The transmission sign blinks when a signal has been send.

TEMPERATURE Button

Room temperature setting.
Value will change quicker when keep pressing.

FAN SPEED Button

This determines the fan speed.
Every time you press this button, the intensity of circulation will change from  (AUTO) to  (HI) to  (MED) to  (LOW) to  (SILENT) (This button allows selecting the optimal or preferred fan speed for each operation mode).

CANCEL Button

Cancel timer reservation.

Precautions for Use

- Do not put the remote controller in the following places.
 - Under direct sunlight.
 - In the vicinity of a heater.
- Handle the remote controller carefully. Do not drop it on the floor, and protect it from water.
- Once the outdoor unit stops, it will not restart for about 3 minutes (unless you turn the power switch off and on or unplug the power cord and plug it in again).
This is to protect the device and does not indicate a failure.
- If you press the FUNCTION selector button during operation, the device may stop for about 3 minutes for protection.

VARIOUS FUNCTIONS

Auto Restart Control

- If there is a power failure, operation will be automatically restarted when the power is resumed with previous operation mode. (As the operation is not stopped by remote controller.)
- If you intend not to continue the operation when the power is resumed, switch off the power supply. When you switch on the circuit breaker, the operation will be automatically restarted with previous operation mode.
Note: 1. If you do not require Auto Restart Control, please consult your sales agent or OFF by remote control.
2. Auto Restart Control is not available when Timer or Sleep Timer mode is set.

AUTOMATIC OPERATION

The device will automatically determine the mode of operation, HEAT, COOL or DEHUMIDIFY depending on the current room temperature. The selected mode of operation will change when the room temperature varies.

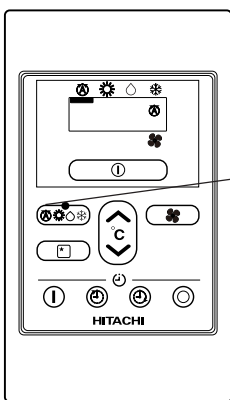

Press the FUNCTION selector so that the display indicates the **A** (AUTO) mode of operation.

- When AUTO has been selected, the device will automatically determine the mode of operation, HEAT, COOL or DEHUMIDIFY depending on the current room temperature. However the mode of operation will not change when indoor unit connected to multi type outdoor unit.
- If the mode automatically selected by the unit is not satisfactory, manually change the mode setting (heat, dehumidify, cool or fan).

START STOP

Press the **1** (START/STOP) button.
Operation starts with a beep.
Press the button again to stop operation.

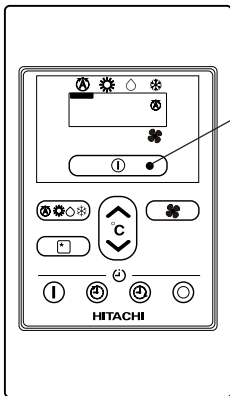

■ As the settings are stored in memory in the remote controller, you only have to press the **1** (START/STOP) button next time.

FAN SPEED (AUTO)

..... When the AUTO fan speed mode is set in the cooling/heating operation:

For the heating operation	<ul style="list-style-type: none"> ● The fan speed will automatically change according to the temperature of discharged air. ● When the difference of room temperature and setting temperature is large, fan starts to run at HI speed. ● When the room temperature reaches setting temperature, fan speed changes to LOW automatically.
For the cooling operation	<ul style="list-style-type: none"> ● When the difference of room temperature and setting temperature is large, fan starts to run at HI speed. ● After room temperature reaches the preset temperature, the cooling operation, which changes the fan speed and room temperature to obtain optimum conditions for natural healthful cooling will be performed.

HEATING OPERATION

- Use the device for heating when the outdoor temperature is under 21°C.
When it is too warm (over 21°C), the heating function may not work in order to protect the device.
- In order to keep reliability of the device, please use this device above -15°C of the outdoor temperature.

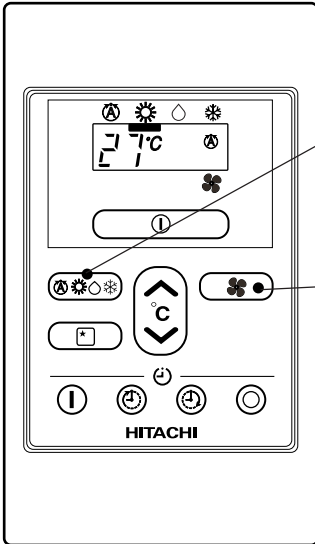

1

Press the FUNCTION selector so that the display indicates ☀ (HEAT).

2

Set the desired FAN SPEED with the 🌀 (FAN SPEED) button (the display indicates the setting).

Ⓐ (AUTO) : The fan speed is HI at first and varies to MED or LOW or SILENT automatically when the preset temperature has been reached.

☰ (HI) : Economical as the room will become warm quickly.
But you may feel a chill at the beginning.

☰ (MED) : Fan speed slow.

☰ (LOW) : Fan speed slower.

☰ (SILENT) : Fan speed ultra slower

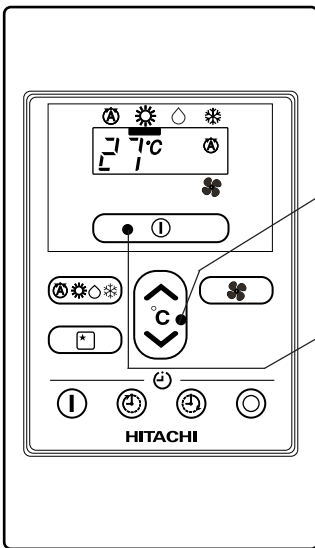

3

Set the desired room temperature with the TEMPERATURE buttons (the display indicates the setting).

The temperature setting and the actual room temperature may vary somewhat depending on conditions.

**START
STOP**

Press the ① (START/STOP) button. Heating operation starts with a beep. Press the button again to stop operation.

- As the settings are stored in memory in the remote controller, you only have to press the ① (START/STOP) button next time.

DEHUMIDIFYING OPERATION

Use the device for dehumidifying when the room temperature is over 16°C.
When it is under 15°C, the dehumidifying function will not work.

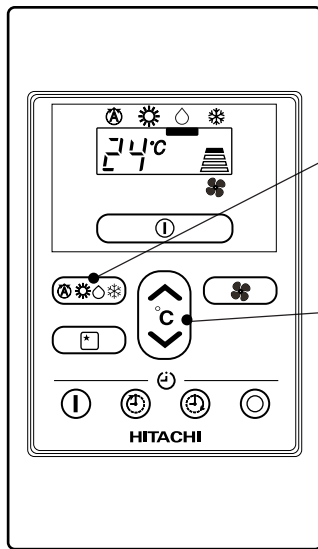

1

Press the FUNCTION selector so that the display indicates ◯ (DEHUMIDIFY).
The FAN SPEED is set at LOW or SILENT.

2

Set the desired room temperature with the TEMPERATURE button (the display indicates the setting).

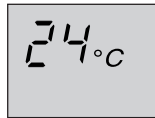

The range of 20-26°C is recommended as the room temperature for dehumidifying.

**START
STOP**

Press the ① (START/STOP) button. Dehumidifying operation starts with a beep. Press the button again to stop operation.

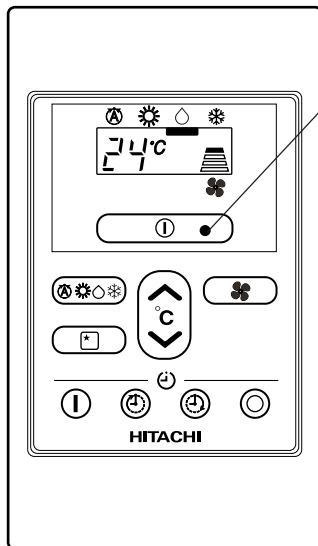

- As the settings are stored in memory in the remote controller, you only have to press the ① (START/STOP) button next time.

■ Dehumidifying Function

When the room temperature is higher than the temperature setting: The device will dehumidify the room, reducing the room temperature to the preset level.

When the room temperature is lower than the temperature setting: Dehumidifying will be performed at the temperature setting slightly lower than the current room temperature, regardless of the temperature setting. The function will stop (the indoor unit will stop emitting air) as soon as the room temperature becomes lower than the setting temperature.

COOLING OPERATION

Use the device for cooling when the outdoor temperature is $-10 \sim 43^{\circ}\text{C}$.
 If indoor humidity is very high (80%), some dew may form on the air outlet grille of the indoor unit.

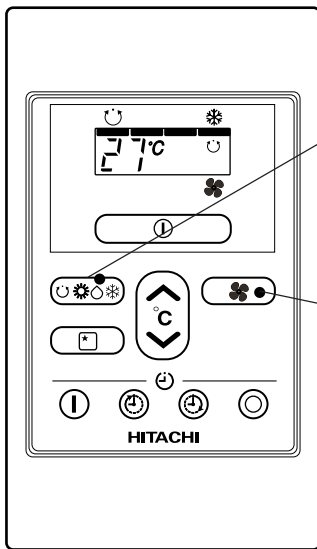

1

Press the FUNCTION selector so that the display indicates ❄️ (COOL).

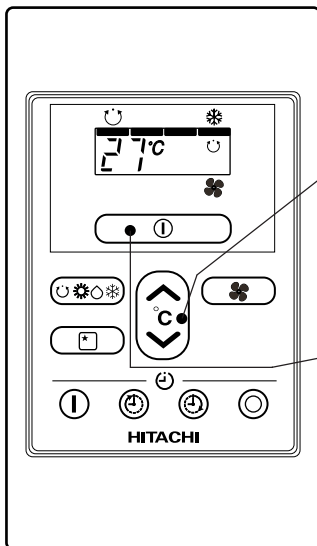

2

Set the desired FAN SPEED with the 🌀 (FAN SPEED) button (the display indicates the setting).

- Ⓐ (AUTO) : The FAN SPEED is HI at first and varies to MED or LOW or SILENT automatically when the preset temperature has been reached.
- 🌀 (HI) : Economical as the room will become cool quickly.
- 🌀 (MED) : Fan speed slow.
- 🌀 (LOW) : Fan speed slower.
- 🌀 (SILENT) : Fan speed ultra slower.

3

Set the desired room temperature with the TEMPERATURE button (the display indicates the setting).

The temperature setting and the actual room temperature may vary some how depending on conditions.

**START
STOP**

Press the ⏻ (START/STOP) button. Cooling operation starts with a beep. Press the button again to stop operation. The cooling function does not start if the temperature setting is higher than the current room temperature (even though the ⏻ (OPERATION) lamp lights). The cooling function will start as soon as you set the temperature below the current room temperature.

- As the settings are stored in memory in the remote controller, you only have to press the ⏻ (START/STOP) button next time.

TIMER RESERVATION

■ ON Timer and OFF Timer are available.

OFF Timer Reservation

1 ⌚ OFF TIME setting

- Select the OFF TIME by pressing the ⌚ (OFF) Button.
- Setting time will change according to the below sequence when you press the button.

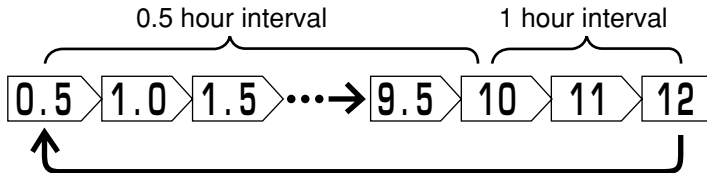

- The value change quicker if you keep pressing the button.

2 Press the Ⓜ (Reserve) button

- OFF TIMER reserved with a signal received sound “beep”.
- The Ⓜ (OFF) Mark starts lighting instead of blinking.

ON Timer Reservation

1 ⌚ ON TIME setting

- Select the ON TIMER by pressing the ⌚ (ON) Button.
- At the beginning of setting, time 6 hours was set.
- Setting time will change according to the below sequence.

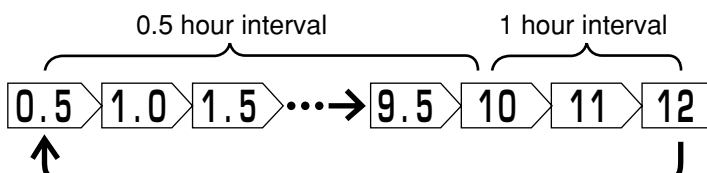

- The value change quicker if you keep pressing the button.

2 Press the Ⓜ (Reserve) button

- ON TIMER reserved with a signal received sound “beep”.
- The Ⓜ (ON) Mark starts lighting instead of blinking.

CANCELLATION of Timer Reservation

1 Press the Ⓞ (Cancel) button

- As the time settings are stored in remote controller memory, you only have to press the Ⓜ (Reserve) button in order to use the same setting next time.

■ Operation stop at setting time

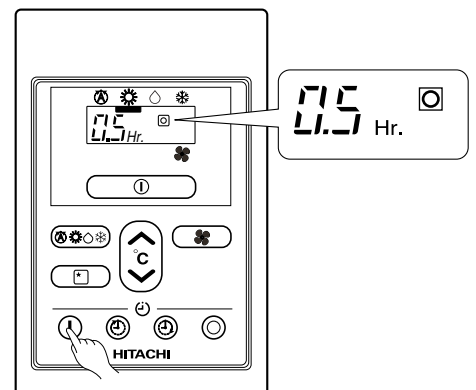
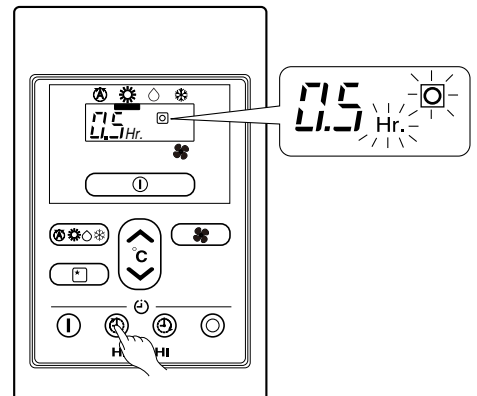

■ Operation will start for setting temperature at setting time (The starting time may different depend on the room temperature and set temperature).

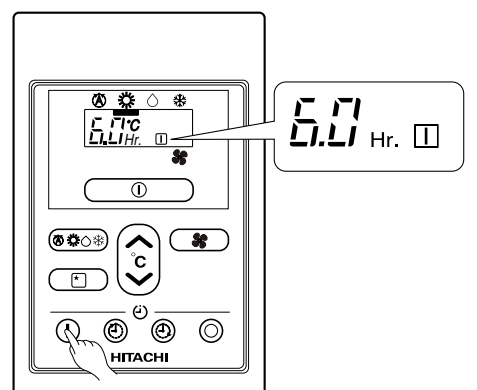
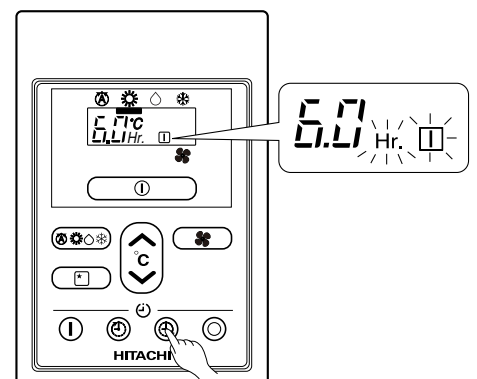

HOW TO SET THE SLEEP TIMER

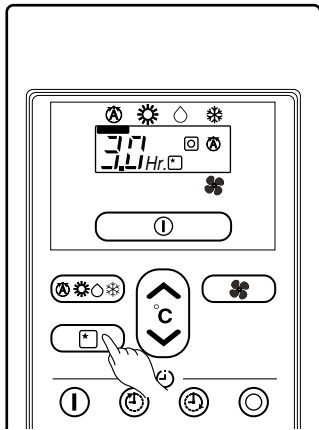

Mode	Indication
Sleep timer	→ 1 hour → 2 hours → 3 hours → 7 hours → Sleep timer off ←

Sleep Timer: The device will continue working for the designated number of hours and then turn off.
Press the SLEEP button, indoor unit will produce a beep.
The timer information will be displayed on the remote controller.

Example: Setting 3 hours sleep time.

How to Cancel Reservation

Press the ○ (CANCEL) button. The ⓘ (RESERVED) sign goes out with a beep.

Explanation of the sleep timer

The device will control the FAN SPEED and room temperature automatically so as to be quiet and good for people's health.

NOTE

- If you set the sleep timer after the off or on-timer has been set, the sleep timer becomes effective instead of the off or on-timer set earlier.
- You can not set other timer during sleep timer operation.
- After sleep timer time is up and when press sleep button again, the sleep timer will be set as last setting.
- Sleep timer effective only once.

CIRCUIT BREAKER

When you do not use the room air conditioner, set the circuit breaker to "OFF".

HOW TO USE THE AIR CONDITIONER EFFECTIVELY

1. An average room temperature setting is probably the best for you as well as being economical.

- Excessive cooling or heating is not recommended for health reasons. High electricity bills may also result.
- Close the curtains or blinds to prevent heat from flowing into or escaping the room as well as to make more effective use of electricity.



2. At intervals, the doors and windows should be opened to let fresh air in.



Make sure the room is ventilated when operating the air conditioner at the same time as other heating appliances.



3. Using the timer is recommended before going to sleep or going out.



4. The following must never be used for cleaning the indoor and outdoor units.

- Benzine, thinner and scrub can damage plastic surfaces or coating.
- Hot water above 40°C can shrink the filter and deform plastic parts.



5. Do not block the air intake and air outlet.

- Do not block the air outlets and intakes of the indoor and outdoor units with curtains or other obstacles which could degrade air conditioner performance and cause unit failure.

THE IDEAL WAYS OF OPERATION

Suitable Room Temperature

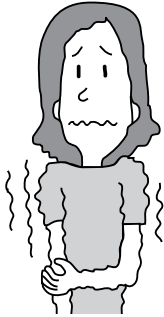

⚠ Warning
Freezing temperature is bad for health and a waste of electric power.

Install curtain or blinds

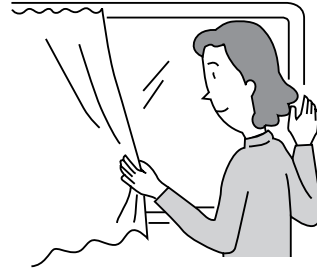

It is possible to reduce heat entering the room through windows.

Ventilation

⚠ Caution
Do not close the room for a long period of time. Occasionally open the door and windows to allow the entrance of fresh air.



Effective Usage Of Timer

At night, please use the "OFF or ON timer operation mode", together with your wake up time in the morning. This will enable you to enjoy a comfortable room temperature. Please use the timer effectively.

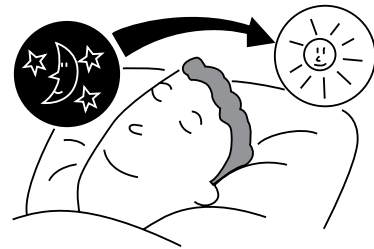

Do Not Forget To Clean The Air Filter

Dusty air filter will reduce the air volume and the cooling efficiency. To prevent from wasting electric energy, please clean the filter every 2 weeks.

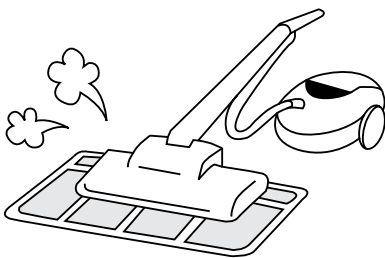

Please Adjust Suitable Temperature For Baby And Children

Please pay attention to the room temperature and air flow direction when operating the unit for baby, children and old folks who have difficulty in movement.

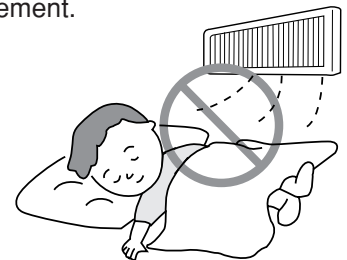

FOR USER'S INFORMATION

The Air Conditioner And The Heat Source In The Room

⚠ Caution

If the amount of heat in the room is above the cooling capability of the air conditioner (for example: more people entering the room, using heating equipments and etc.), the preset room temperature cannot be achieved.

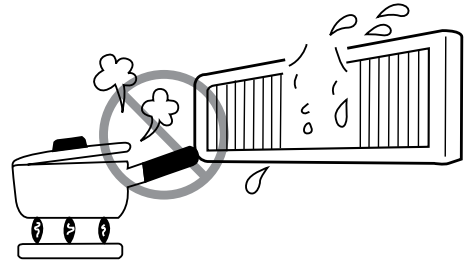

Not Operating For A Long Time

When the indoor unit is not to be used for a long period of time, please switch off the power from the mains. If the power from mains remains "ON", the indoor unit still consumes about 8W in the operation control circuit even if it is in "OFF" mode.

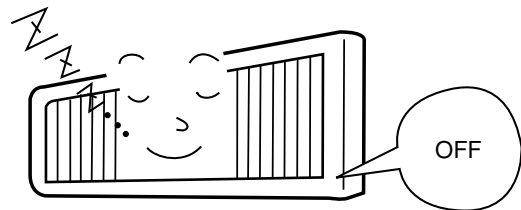

When Lightning Occurs

⚠ Warning

To protect the whole unit during lightning, please stop operating the unit and remove the plug from the socket.

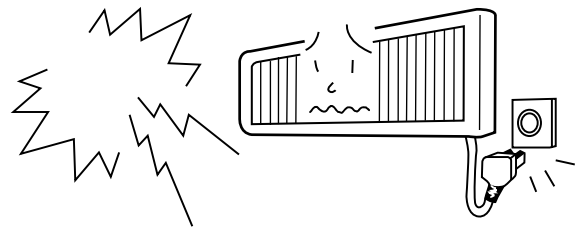

Interference From Electrical Products

⚠ Caution

To avoid noise interference, please place the indoor unit and its remote controller at least 1m away from electrical products.

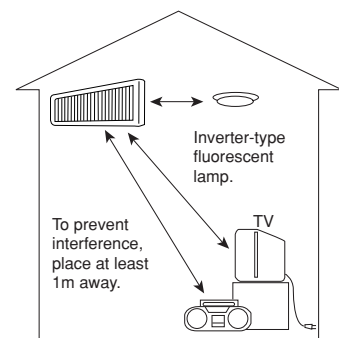

MAINTENANCE

▲ WARNING

- Before cleaning, stop unit operation with the remote controller and turn off the circuit breaker.

▲ CAUTION

- Do not expose the unit to water as it may cause an electric shock.
- For cleaning inside the air conditioner, consult your sales agent.
- Avoid using detergent when cleaning the heat exchanger of the indoor unit. Unit failure may result.
- When cleaning the heat exchanger with a vacuum cleaner, make sure to wear gloves so as not to injure your hands on the heat exchanger fins.

1. AIR FILTER

Clean the air filter, as it removes dust inside the room. Be sure to clean the filter once every two weeks so as not to consume electricity unnecessarily.

PROCEDURE

- 1** Pull the filter toward the center until it detached from the holders. Then take it out from holders (refer to diagram).
- 2** Remove dust from the filter using a vacuum cleaner. If there is too much dust, use neutral detergent. After using neutral detergent, wash with clean water and dry in the shade.
- 3** Install the filters. Gently insert back the filter into the holders.

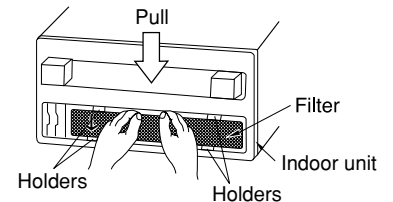
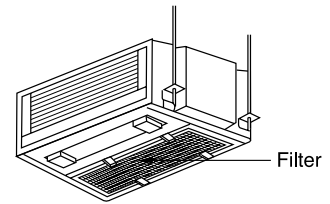

▲ CAUTION

- Do not wash with hot water at more than 40°C. The filter may shrink.
- When washing it, shake off moisture completely and dry it in the shade; do not expose it directly to the sun. The filter may shrink.
- Do not operate the air conditioner with the filter removed. Dust may enter the air conditioner and cause trouble.

REGULAR INSPECTION

PLEASE CHECK THE FOLLOWING POINTS BY QUALIFIED SERVICE PERSONAL EITHER EVERY HALF YEARLY OR YEARLY. CONTACT YOUR SALES AGENT OR SERVICE SHOP.

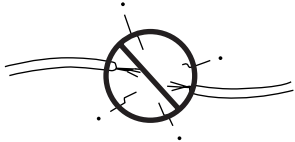
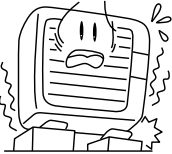
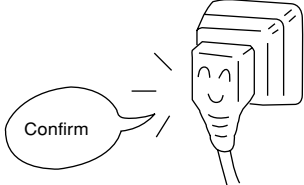
1		Is the earth line disconnected or broken?
2		Is the mounting frame seriously affected by rust and is the outdoor unit tilted or unstable?
3		Is the plug of power line firmly plugged into the socket? (Please ensure no loose contact between them).

AFTER SALE SERVICE AND WARRANTY

WHEN ASKING FOR SERVICE, CHECK THE FOLLOWING POINTS.

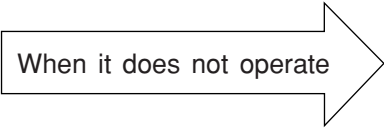
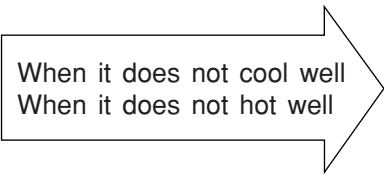
CONDITION	CHECK THE FOLLOWING POINTS
	<ul style="list-style-type: none"> ● Is the fuse all right? ● Is the voltage extremely high or low? ● Is the circuit breaker "ON"?
	<ul style="list-style-type: none"> ● Was the air filter cleaned? ● Does sunlight fall directly on the outdoor unit? ● Is the air flow of the outdoor unit obstructed? ● Are the doors or windows opened, or is there any source of heat in the room? ● Is the set temperature suitable?



Notes

- In quiet or stop operation, the following phenomena may occasionally occur, but they are not abnormal for the operation.
 - (1) Slight flowing noise of refrigerant in the refrigerating cycle.
 - (2) Slight rubbing noise from the fan casing which is cooled and then gradually warmed as operation stops.
- The odor will possibly be emitted from the room air conditioner because the various odor, emitted by smoke, foodstuffs, cosmetics and so on, sticks to it. So the air filter and the evaporator regularly must be cleaned to reduce the odor.

- Please contact your sales agent immediately if the air conditioner still fails to operate normally after the above inspections. Inform your agent of the model of your unit, production number, date of installation. Please also inform him regarding the fault.
- Power supply shall be connected at the rated voltage, otherwise electronic component of the unit will be broken or could not reach the specified capacity.

Please note:

On switching on the equipment, particularly when the room light is dimmed, a slight brightness fluctuation may occur. This is of no consequence.

The conditions of the local Power Supply Companies are to be observed.

Note

- Avoid to use the room air conditioner for cooling operation when the outside temperature is below 21°C (70°F).
The recommended maximum and minimum operating temperatures of the hot and cold sides should be as below:

		Cooling		Heating	
		Minimum	Maximum	Minimum	Maximum
Indoor	Dry bulb °C	21	32	20	27
	Wet bulb °C	15	23	12	19
Outdoor	Dry bulb °C	21	43	2	21
	Wet bulb °C	15	26	1	15

MEMO

.....

.....

.....

.....

.....

.....

.....

.....

.....

.....

.....

.....

.....

.....

.....

.....

.....

.....

.....

.....

.....

.....

.....

.....

CONSTRUCTION AND DIMENSIONAL DIAGRAM FOR INDOOR

MODEL RAD-18NH7A, RAD-25NH7A, RAD-35NH7A, RAD-50NH7A*

Unit: mm

wired remote controller (Length : 15m)

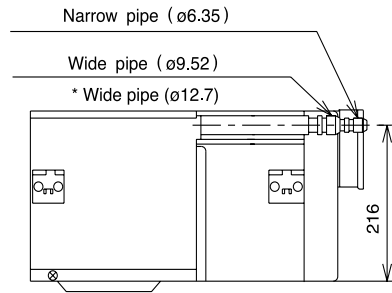
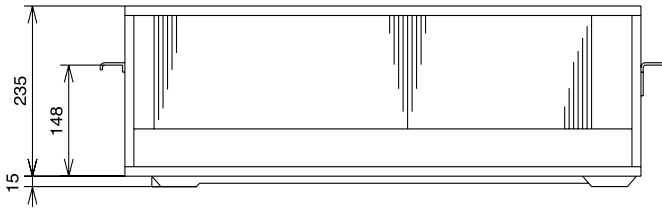
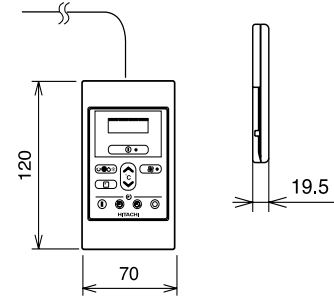
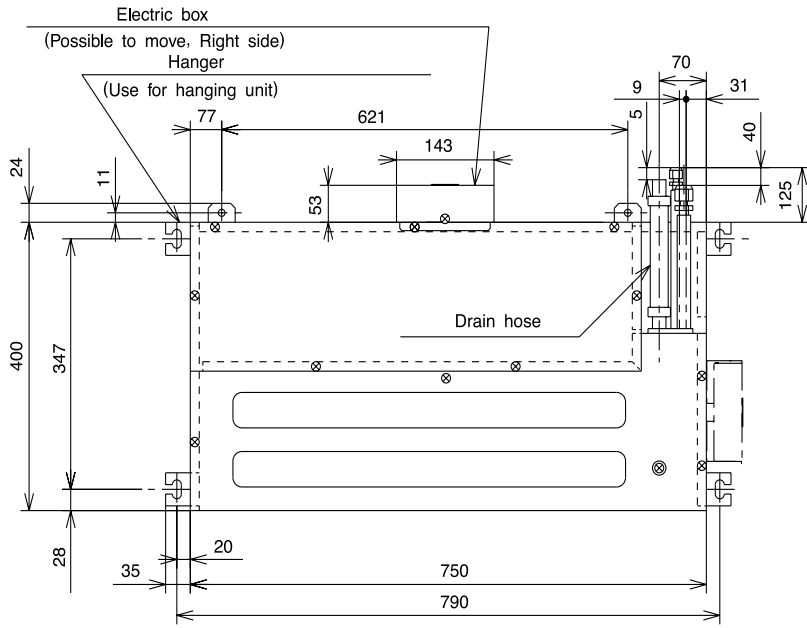

BACK SUCTION

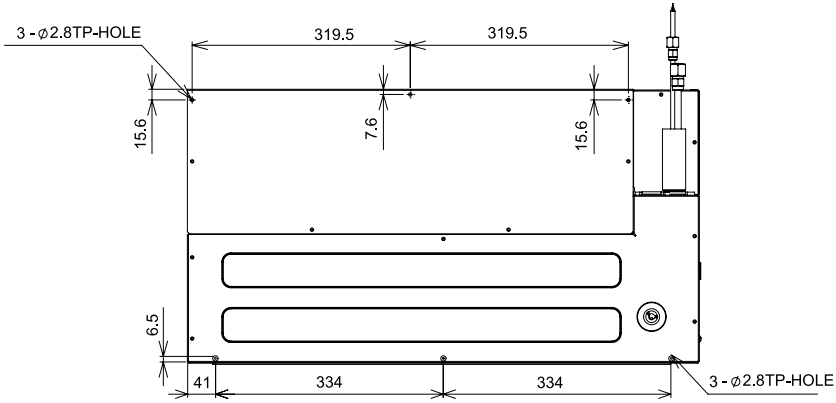
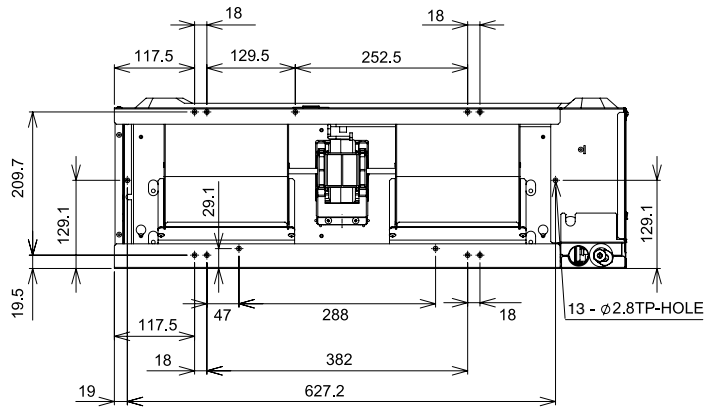

DISCHARGE

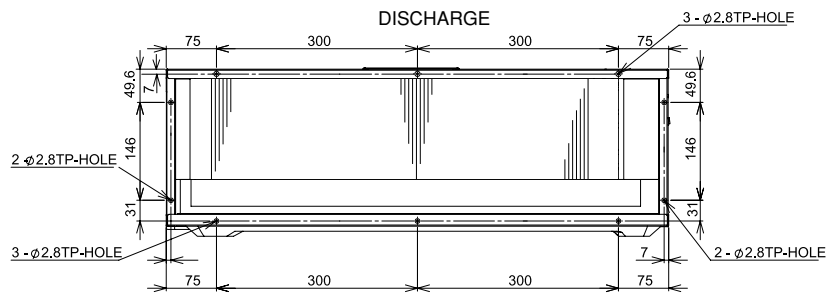

BOTTOM SUCTION

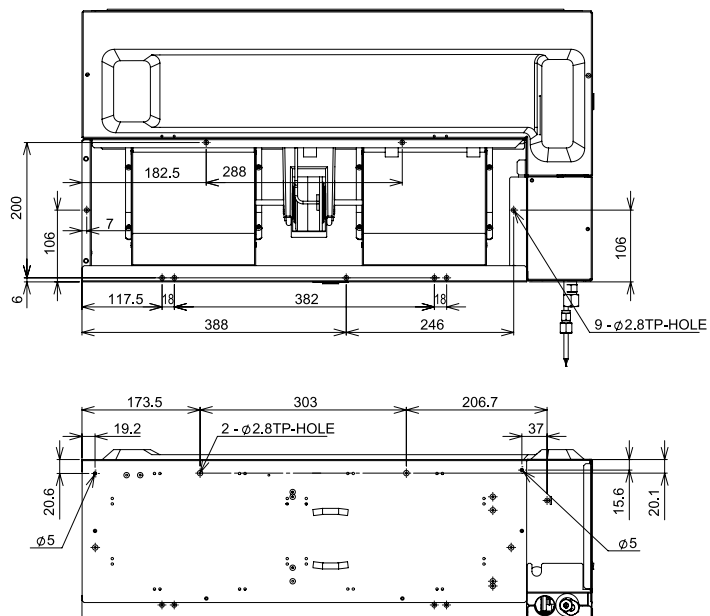

Cautions:

1. Use insulated pipes for both large and small diameters.

CONSTRUCTION AND DIMENSIONAL DIAGRAM FOR OUTDOOR
MODEL RAC-25NH5, RAC-35NH5

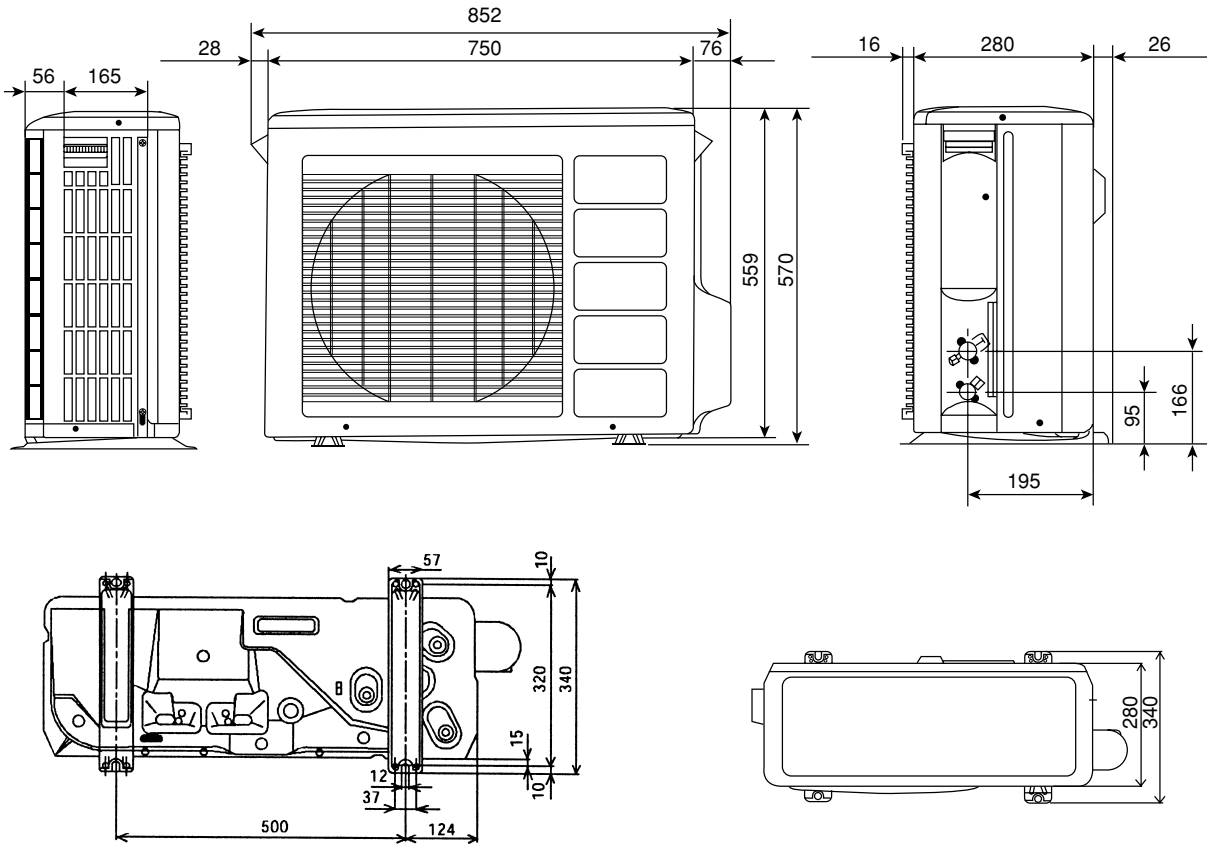

MODEL RAC-50NH5

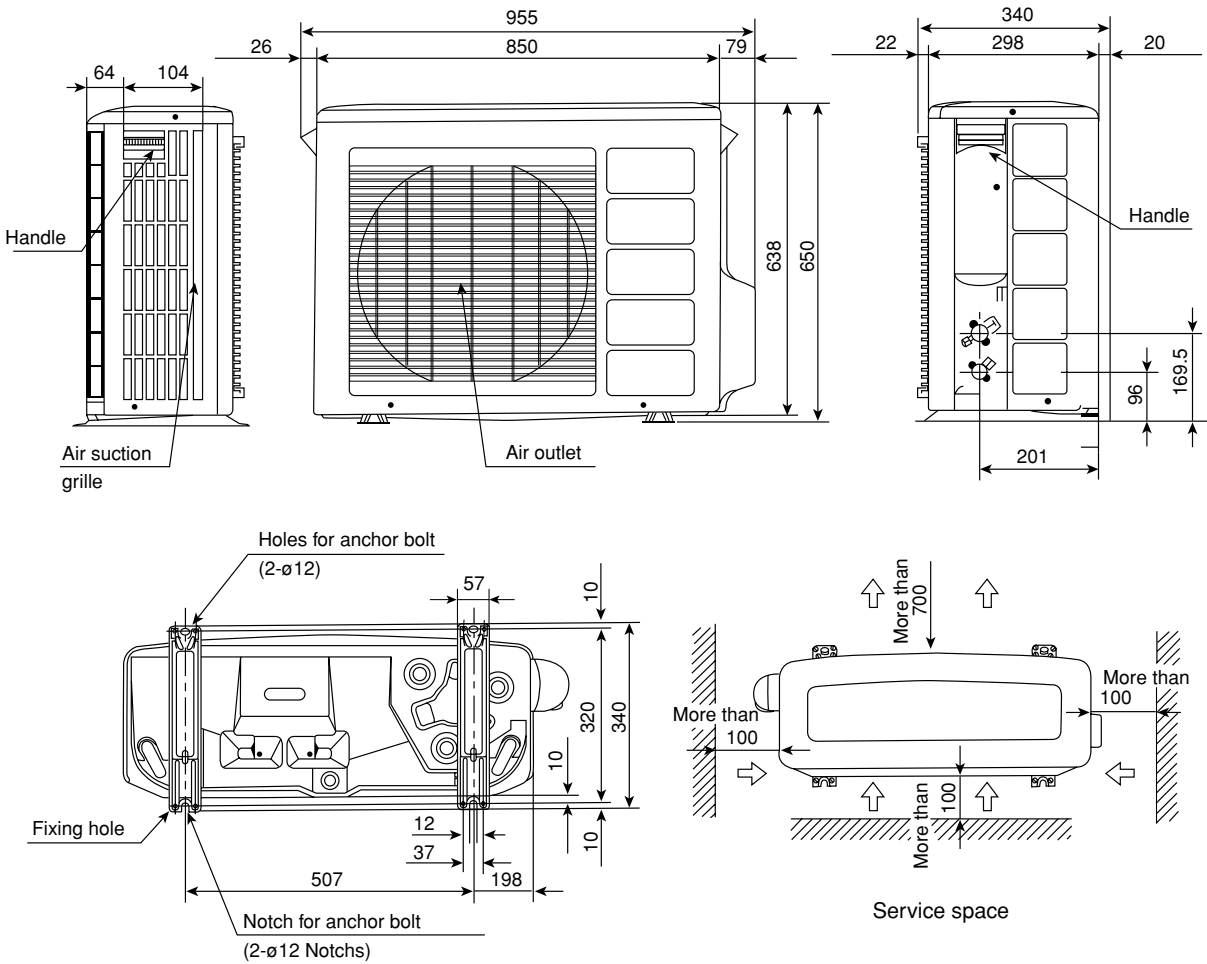

MAIN PARTS COMPONENT

THERMOSTAT

Thermostat Specifications

MODEL			RAD-18NH7A, RAD-25NH7A, RAD-35NH7A, RAD-50NH7A	
THERMOSTAT MODEL			IC	
OPERATION MODE			COOL	HEAT
TEMPERATURE °C (°F)	INDICATION 16	ON	14.9 (59.3)	20.4 (68.8)
		OFF	14.3 (58.3)	21.0 (69.1)
	INDICATION 24	ON	22.9 (73.7)	28.4 (83.1)
		OFF	22.3 (72.7)	29.0 (84.1)
	INDICATION 32	ON	30.9 (88.1)	36.4 (97.7)
		OFF	30.3 (87.1)	37.0 (98.8)

FAN MOTOR

Fan Motor Specifications

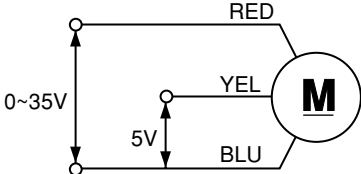
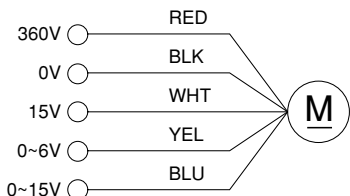
MODEL	RAD-18NH7A, RAD-25NH7A, RAD-35NH7A, RAD-50NH7A	RAC-25NH5, RAC-35NH5, RAC-50NH5
POWER SOURCE	DC: 0 ~ 35V	DC360V
OUTPUT	20W	40W
CONNECTION		

BLU : BLUE

YEL : YELLOW

BRN : BROWN

WHT : WHITE

GRY : GRAY

ORN : ORANGE

GRN : GREEN

RED : RED

BLK : BLACK

PNK : PINK

VIO : VIOLET

COMPRESSOR MOTOR

Compressor Motor Specifications

MODEL		RAC-25NH5. RAC-35NH5	RAC-50NH5
COMPRESSOR MODEL		JU1012D	JU1013D
PHASE		SINGLE	
RATED VOLTAGE		AC 220 ~ 240 V	
RATED FREQUENCY		50 Hz	
POLE NUMBER		4	
CONNECTION			
RESISTANCE VALUE (Ω)	20°C (68°F)	2M = 1.05	
	75°C (167°F)	2M = 1.28	

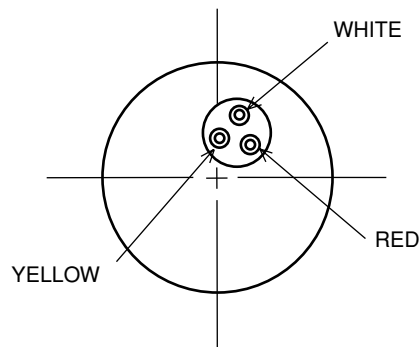

CAUTION

When the refrigerating cycle has been operated for a long time with the capillary tubes clogged or crushed or with too little refrigerant, check the color of the refrigerating machine oil inside the compressor. If the color has been changed conspicuously, replace the compressor.

WIRING DIAGRAM

MODEL RAD-18NH7A, RAD-25NH7A, RAD-35NH7A, RAD-50NH7A
 RAC-25NH5, RAC-35NH5, RAC-50NH5

BLU : BLUE
 GRY : GRAY
 BLK : BLACK

YEL : YELLOW
 ORN : ORANGE
 PNK : PINK

BRN : BROWN
 GRN : GREEN
 VIO : VIOLET

WHT : WHITE
 RED : RED

OUTDOOR UNIT

INDOOR UNIT

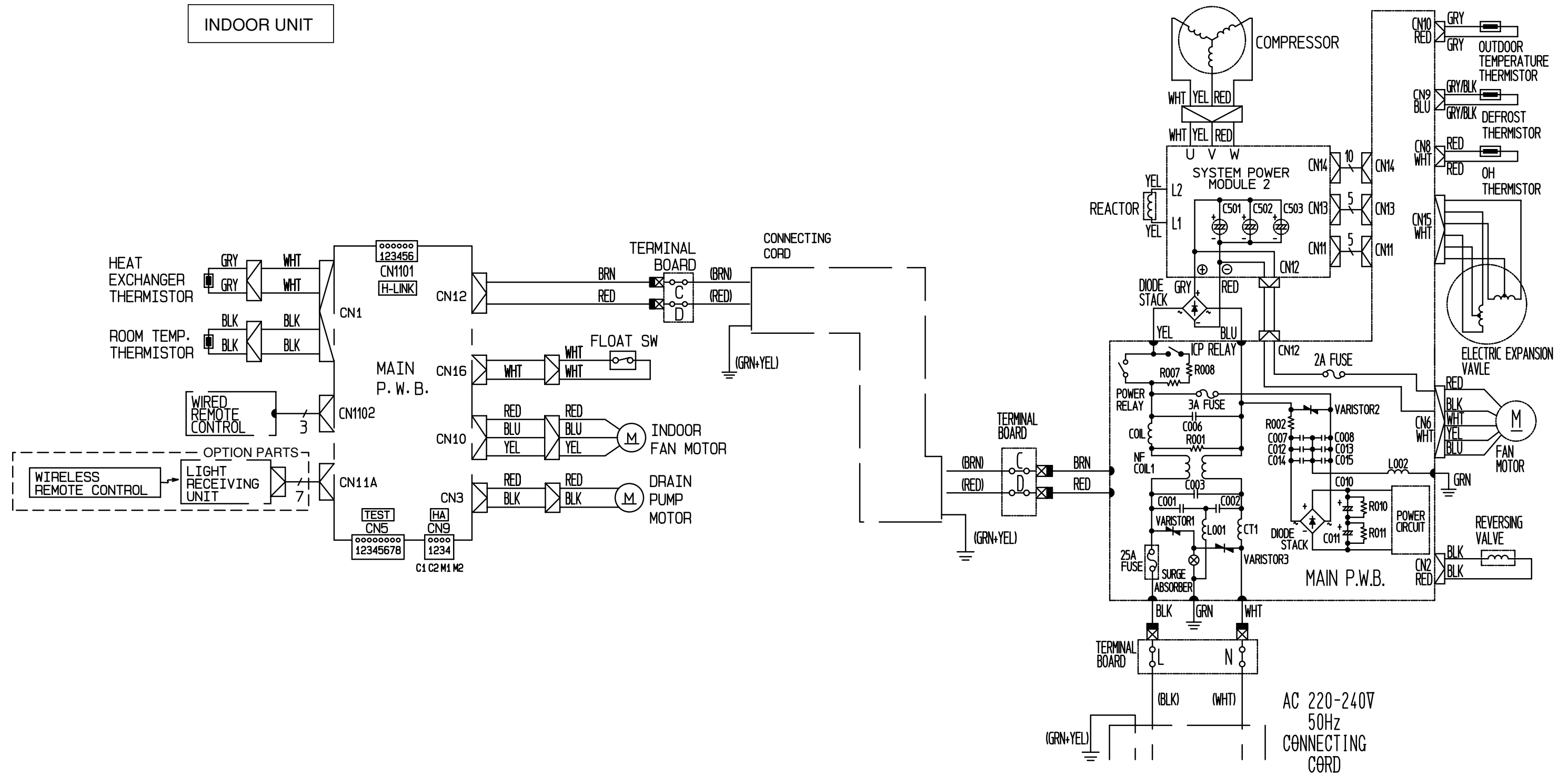

AC 220-240V
 50Hz
 CONNECTING
 CORD

CIRCUIT DIAGRAM

Wired Remote Control

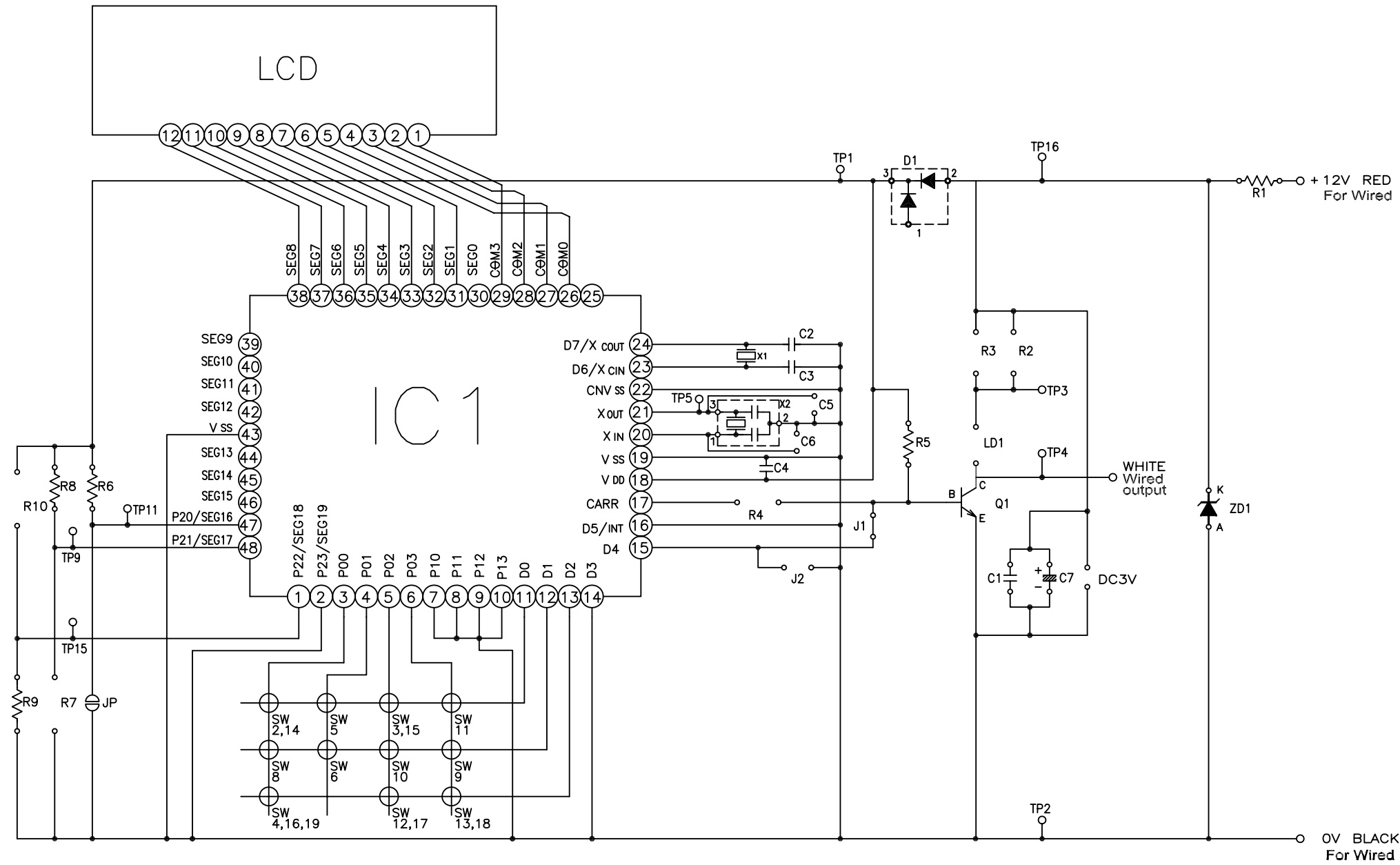

IC

Symbol	Specification	Form
IC1	M34552G8HFP...OTPMICON	F
	M34552M4H-116FP...MASKMICON	

LCD

Symbol	Specification	Form
LCD	LCD-53WA	H

Diode

Symbol	Specification	Form
D1	RB425D	C

Zener diode

Symbol	Specification	Form
ZD1	HZK3BTR	C

D-Capacitor

Symbol	Specification	Form
C7	100μF, 6.3V	F

Transistor

Symbol	Specification	Form
Q1	2SD1328S-TX	C

Size of Resistor and C-Capacitor
 3 . . . 3216 Size
 2 . . . 2125 Size
 1 . . . 1608 Size

Resonators

Symbol	Specification	Form
X1	C-R002RX 32.768kHz	H
X2	CSTCC3.64MGOH6 3.64MHz	F

Resistor

Symbol	Specification	Size	Form
R1	1.5kΩ, 1/8W	2	C
R5	3kΩ, 1/16W	1	C
R6	100kΩ, 1/16W	1	C
R8	10kΩ, 1/16W	1	C
R9	10kΩ, 1/16W	1	C

Chip-jumper

Symbol	Specification	Size	Form
J1	0Ω	1	C

C-Capacitor

Symbol	Specification	Characteristics	Size	Form
C1	1μF, 16V	F	2	C
C2	22pF, 50V	CH	2	C
C3	22pF, 50V	CH	2	C
C4	1μF, 16V	F	2	C

Table1 Key-matrix table

	P00	P01	P02	P03
D0	✕	○	⊗	
D1	⊙	⊕	∧	∨
D2	⓪	Ⓛ	Ⓜ	Ⓨ

CIRCUIT DIAGRAM

MODEL RAC-25NH5, RAC-35NH5, RAC-50NH5

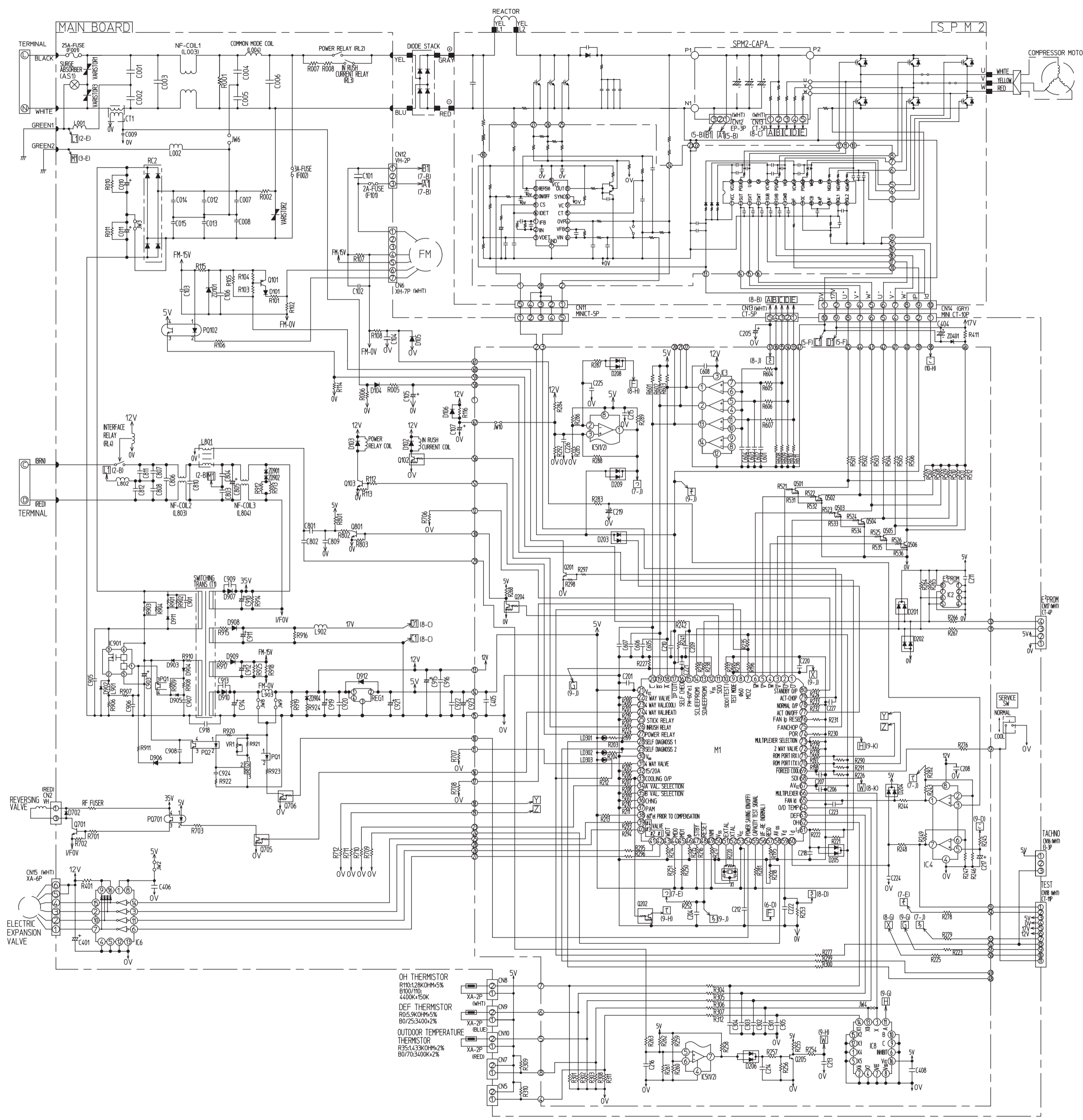

RESISTORS

MARK RATING (R) (%) (W) MOUNTING BOARD REMARK

RESISTORS

MARK RATING (R) (%) (W) MOUNTING BOARD REMARK

CAPACITORS

MARK RATING (U.F.) (V) MOUNTING BOARD REMARK

LEDS

MARK M0DEL MOUNTING BOARD REMARK

COILS

MARK M0DEL MOUNTING BOARD REMARK

ZENER DIODES

MARK M0DEL MOUNTING BOARD REMARK

OSCILLATOR

MARK M0DEL MOUNTING BOARD REMARK

TRANSISTORS

MARK M0DEL MOUNTING BOARD REMARK

JUMPERS

MARK M0DEL MOUNTING BOARD REMARK

DIODES

MARK M0DEL MOUNTING BOARD REMARK

CONNECTORS

MARK M0DEL MOUNTING BOARD REMARK

PHOTOCOUPLEDERS

MARK M0DEL MOUNTING BOARD REMARK

VARIABLE RESISTOR

VR1 RATING MOUNTING BOARD REMARK

FUSE

MARK M0DEL MOUNTING BOARD REMARK

RELAYS

MARK M0DEL MOUNTING BOARD REMARK

SWITCH

MARK M0DEL MOUNTING BOARD REMARK

MARK	RATING (R) (%) (W)	MOUNTING BOARD	REMARK
R001	470K 5% 1/2 A M		
R002	22 5% 1/4 A M		
R003	169K 5% 1/4 A M		
R004	1K 5% 1/4 A M		
R005	10K 5% 1/4 A M		
R006	100 5% 1/4 A M		
R007	100 5% 1/4 A M		
R008	100 5% 1/4 A M		
R009	100 5% 1/4 A M		
R010	470K 5% 1/2 A M		
R011	470K 5% 1/2 A M		
R101	36K 1% 1/4 A M		
R102	3K 1% 1/4 A M		
R103	30K 5% 1/2 A M		
R104	330K 5% 1/4 A M		
R105	75K 5% 1/4 A M		
R106	24K 5% 1/4 A M		
R107	10K 5% 1/4 A M		
R108	510 5% 1/4 A M		
R112	10K 5% 1/4 A M		
R113	75K 5% 1/4 A M		
R114	51K 5% 1/4 A M		
R115	JUMPER A M		
R116	JUMPER A M		
R195	1K 5% 1/4 A M		
R196	1K 5% 1/4 A M		
R197	1K 5% 1/4 A M		
R198	1K 5% 1/4 A M		
R199	1K 5% 1/4 A M		
R200	10K 5% 1/4 A M		
R201	10K 5% 1/4 A M		
R202	10K 5% 1/4 A M		
R203	390 5% 1/4 A M		
R204	390 5% 1/4 A M		
R205	1K 5% 1/4 A M		
R206	10K 5% 1/4 A M		
R207	10K 5% 1/4 A M		
R208	1K 5% 1/4 A M		
R209	10K 5% 1/4 A M		
R210	10K 5% 1/4 A M		
R211	10K 5% 1/4 A M		
R212	390 5% 1/4 A M		
R213	10K 5% 1/4 A M		
R214	10K 5% 1/4 A M		
R215	10K 5% 1/4 A M		
R216	10K 5% 1/4 A M		
R217	10K 5% 1/4 A M		
R218	10K 5% 1/4 A M		
R219	1K 5% 1/4 A M		
R220	1K 5% 1/4 A M		
R221	10K 5% 1/4 A M		
R222	10K 5% 1/4 A M		
R223	1K 5% 1/4 A M		
R224	1K 5% 1/4 A M		
R225	1K 5% 1/4 A M		
R226	1K 5% 1/4 A M		
R227	10K 5% 1/4 A M		
R228	10K 5% 1/4 A M		
R229	10K 5% 1/4 A M		
R230	10K 5% 1/4 A M		
R231	10K 5% 1/4 A M		
R232	10K 5% 1/4 A M		
R233	10K 5% 1/4 A M		
R234	1K 5% 1/4 A M		
R235	10K 5% 1/4 A M		
R236	10K 5% 1/4 A M		
R237	10K 5% 1/4 A M		
R238	100 5% 1/4 A M		
R239	100 5% 1/4 A M		
R240	100 5% 1/4 A M		
R241	56K 5% 1/4 A M		
R242	1K 5% 1/4 A M		
R243	2K 1% 1/4 A M		
R244	2K 1% 1/4 A M		
R245	10K 5% 1/4 A M		
R246	1K 5% 1/4 A M		
R247	3.6K 1% 1/4 A M		
R248	2K 1% 1/4 A M		
R249	20K 1% 1/4 A M		
R250	10K 5% 1/4 A M		
R251	10K 5% 1/4 A M		
R252	10K 5% 1/4 A M		
R253	3.3K 1% 1/4 A M		
R254	100 5% 1/4 A M		
R255	2K 5% 1/4 A M		
R256	10K 5% 1/4 A M		
R257	10K 5% 1/4 A M		
R258	10K 5% 1/4 A M		
R259	10K 5% 1/4 A M		
R260	10K 5% 1/4 A M		
R261	10K 5% 1/4 A M		
R262	10K 5% 1/4 A M		
R263	10K 5% 1/4 A M		
R264	51K 5% 1/4 A M		
R265	51K 5% 1/4 A M		
R266	390 5% 1/4 A M		
R267	390 5% 1/4 A M		
R268	2K 5% 1/4 A M		
R276	100 5% 1/4 A M		
R277	100 5% 1/4 A M		
R278	100 5% 1/4 A M		
R279	100 5% 1/4 A M		
R281	10K 5% 1/4 A M		
R282	5% 1/4 A M		
R283	1K 5% 1/4 A M		
R284	10K 5% 1/4 A M		
R285	4.7K 5% 1/4 A M		
R286	51K 5% 1/4 A M		
R287	10K 5% 1/4 A M		
R288	51K 5% 1/4 A M		
R289	51K 5% 1/4 A M		
R290	10K 5% 1/4 A M		
R291	10K 5% 1/4 A M		
R292	10K 5% 1/4 A M		
R293	100 5% 1/4 A M		
R294	100 5% 1/4 A M		
R295	100 5% 1/4 A M		
R296	100 5% 1/4 A M		
R297	10K 5% 1/4 A M		
R298	51K 5% 1/4 A M		
R299	100 5% 1/4 A M		
R300	100 5% 1/4 A M		
R301	3.74K 1% 1/4 A M		
R302	3.09K 1% 1/4 A M		
R303	3.09K 1% 1/4 A M		
R304	100 5% 1/4 A M		
R305	100 5% 1/4 A M		
R306	100 5% 1/4 A M		
R307	100 5% 1/4 A M		

BLOCK DIAGRAM

MODEL RAD-18NH7A, RAD-25NH7A, RAD-35NH7A, RAD-50NH7A
 RAC-25NH5, RAC-35NH5, RAC-50NH5

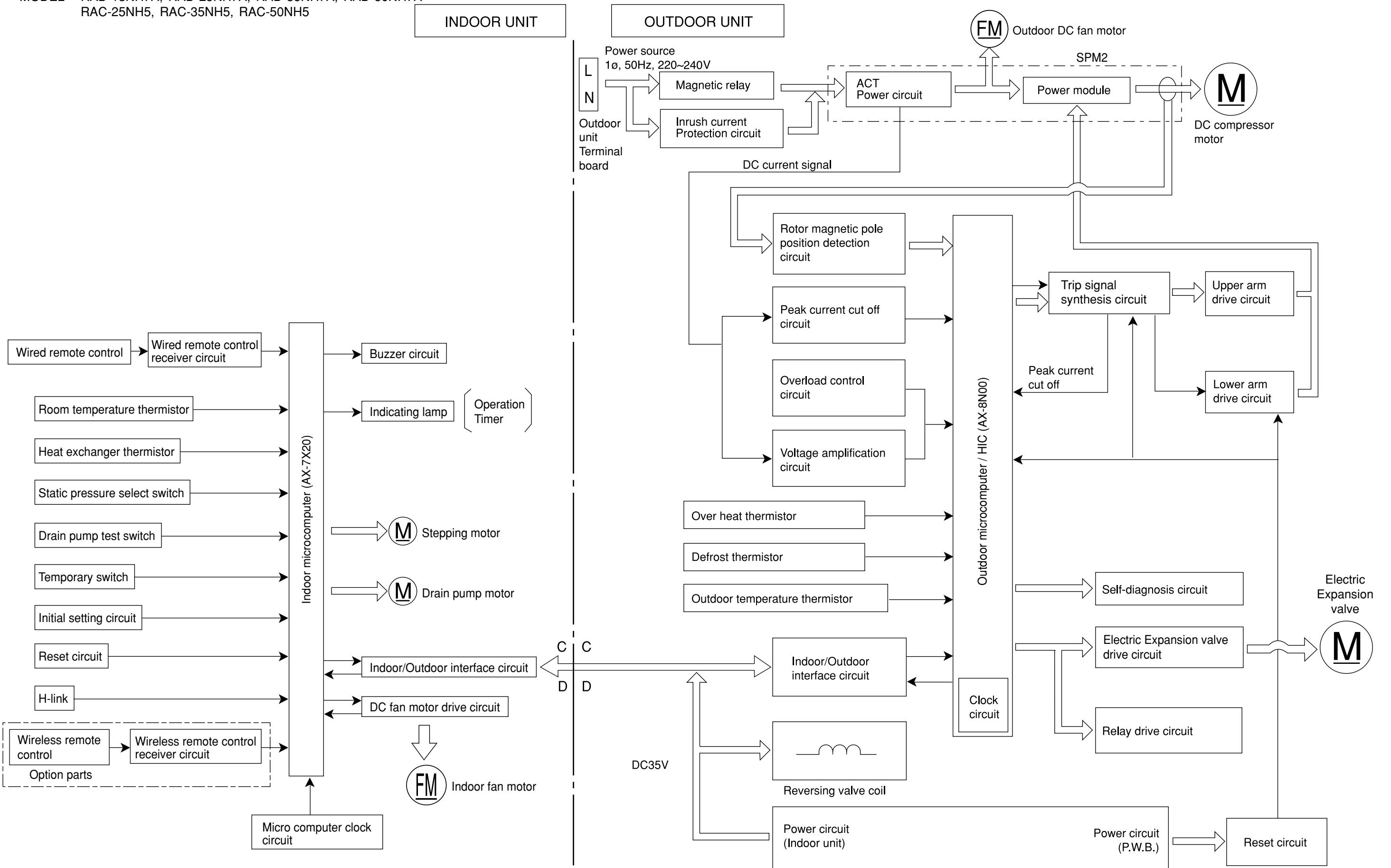

BASIC MODE

MODEL RAD-18NH7A, RAD-25NH7A, RAD-35NH7A, RAD-50NH7A

Operation mode	Fan	Cooling	Dehumidifying (dehumidifying operation by the function select button only, not including that engaged by the dehumidify button)	Heating	Auto										
Basic operation of start/stop switch															
Timer functions	Off-timer														
	On-timer														
	Off -> On On -> Off timer														
Fan speed mode (indoor fan)	Auto	<p>Changes from "Hi" to "Med" or "Lo" depending on room temperature.</p> <p>1. Runs at "Hi" until first thermo off after operation is started. 2. Runs at "Lo" when thermo is off.</p>	<p>Changes between "Lo" and "Med" depending on the room temperature.</p> <table border="1"> <thead> <tr> <th>Temperature division</th> <th>Fan speed</th> </tr> </thead> <tbody> <tr> <td>Division 1</td> <td>Lo</td> </tr> <tr> <td>Division 2</td> <td>Lo</td> </tr> <tr> <td>Division 3</td> <td>Med</td> </tr> <tr> <td>Division 4</td> <td>Med</td> </tr> </tbody> </table> <p>1. The indoor fan also stops when the compressor is in stop status.</p>	Temperature division	Fan speed	Division 1	Lo	Division 2	Lo	Division 3	Med	Division 4	Med	<p>Set to "ultra-Lo", "Lo", "Med", "Hi", "ultra-Hi" or "stop" depending on the room temperature, time and heat exchange temperature. Set to "stop" if the room temperature is 18°C in the "ultra-Lo" mode other than during preheating (cooling is recovered at 18.33°C).</p> <p>When the compressor is running at maximum speed during hot dash or when recovered from defrosting.</p> <p>In modes other than left</p>	<p>Operating mode is judged by room temperature and outdoor temperature.</p> <p>(1) Judging by outdoor temperature</p> <ul style="list-style-type: none"> Operating mode is judged by outdoor temperature. Only when the mode is not restricted by this judgment, the judgment by room temperature in the next paragraph will be performed. (a) Outdoor temperature $\geq 27^\circ\text{C}$: Restricted to cooling (b) Outdoor temperature $\leq 16^\circ\text{C}$: Restricted to heating <p>(2) Judging by room temperature</p> <p>Operating mode at start up is judged (initial judgment)</p> <p>(a) Conditions for judgment (any of the followings)</p> <ul style="list-style-type: none"> When auto operation is started after 1 hour has elapsed since the operation was stopped. When auto operation is started after the previous manual mode operation. When the operating mode is switched to auto while operating at manual mode. <p>(b) Judging method</p> <ul style="list-style-type: none"> Room temperature $\geq 25^\circ\text{C} \pm 3^\circ\text{C}$: Cooling Room temperature $< 25^\circ\text{C} \pm 3^\circ\text{C}$: Heating * $\pm 3^\circ\text{C}$ is the fine adjustment value from the wireless remote controller. <p>Judging operating mode change during operation (Continuous judgment)</p> <p>(a) Conditions for judgment (any of the followings)</p> <ul style="list-style-type: none"> The mode is reviewed at every interval time. When auto operation is started again before 1 hour has elapsed since the operation was stopped. <p>(b) Judging method</p> <ul style="list-style-type: none"> Judge by setting the hysteresis on the final preset temperature. The final preset temperature is the actually targeted preset temperature which is the sum of the basic preset temperature and each type of shift value (e.g. by remote controller, preset temperature correction value, powerful shift value, etc.). <p>[Currently cooling]</p> <ul style="list-style-type: none"> Room temperature \leq Final preset temperature -3°C Change to heating Room temperature $>$ Final preset temperature -3°C Continue cooling <p>[Currently heating]</p> <ul style="list-style-type: none"> Room temperature \geq Final preset temperature $+2^\circ\text{C}$ Change to cooling Room temperature $<$ Final preset temperature $+2^\circ\text{C}$ Continue heating
	Temperature division	Fan speed													
	Division 1	Lo													
	Division 2	Lo													
Division 3	Med														
Division 4	Med														
Hi	Operates at "Hi" regardless of the room temperature.	Set to "ultra-Hi" when the compressor runs at maximum speed, and to "Hi" in other modes.	Set to "Hi" in modes other than when the compressor stops.	Set to "ultra-Lo", "Lo", "Med", "Hi", "ultra-Hi" or "stop" depending on the room temperature, and time. Set to "stop" if the room temperature is 18°C in the "ultra-Lo" mode other than during preheating (cooling is recovered at 18.33°C). Set to "ultra-Hi" when the compressor is running at maximum speed during hot dash or when recovered from defrosting.	<p>Judging operating mode change during operation (Continuous judgment)</p> <p>(a) Conditions for judgment (any of the followings)</p> <ul style="list-style-type: none"> The mode is reviewed at every interval time. When auto operation is started again before 1 hour has elapsed since the operation was stopped. <p>(b) Judging method</p> <ul style="list-style-type: none"> Judge by setting the hysteresis on the final preset temperature. The final preset temperature is the actually targeted preset temperature which is the sum of the basic preset temperature and each type of shift value (e.g. by remote controller, preset temperature correction value, powerful shift value, etc.). <p>[Currently cooling]</p> <ul style="list-style-type: none"> Room temperature \leq Final preset temperature -3°C Change to heating Room temperature $>$ Final preset temperature -3°C Continue cooling <p>[Currently heating]</p> <ul style="list-style-type: none"> Room temperature \geq Final preset temperature $+2^\circ\text{C}$ Change to cooling Room temperature $<$ Final preset temperature $+2^\circ\text{C}$ Continue heating 										
Med	Operates at "Med" regardless of the room temperature.	Same as at left.	Set to "Med" in modes other than when the compressor stops.	Set to "ultra-Lo", "Lo", "Med" or "stop" depending on the room temperature and time. Set to "stop" if the room temperature is 18°C in the "ultra-Lo" mode other than during preheating (cooling is recovered at 18.33°C).											
Lo	Operates at "Lo" regardless of the room temperature.	Same as at left.	Set to "Lo" in modes other than when the compressor stops.	Set to "ultra-Lo", "Lo", or "stop" depending on the room temperature and time. Set to "stop" if the room temperature is 18°C in the "ultra-Lo" mode other than during preheating (cooling is recovered at 18.33°C). The fan speed is controlled by the heat exchanger temperature; the overload control is executed as in the following diagram:											
Basic operation of temperature controller	<p>Performs only fan operation at the set speed regardless of the room temperature.</p>	See page 47.	See page 51.	See page 53.											
Sleep operation (with sleep button ON)	<ul style="list-style-type: none"> Enters sleep operation after set as on the left. Action during sleep operation Lo (sleep) operation 	<ul style="list-style-type: none"> Same as at left See page 49. 	<ul style="list-style-type: none"> Same as at left See page 51. 	<ul style="list-style-type: none"> Same as at left See page 55. 	<ul style="list-style-type: none"> Same as at left. Performs the sleep operation of each operation mode. 										

Table 1 Mode data file

	RAD-18NH7A	RAD-25NH7A	RAD-35NH7A	RAD-50NH7A
LABEL NAME	VALUE			
WMAX	4400 min ⁻¹	4400 min ⁻¹	5500 min ⁻¹	5100 min ⁻¹
WMAX2	4500 min ⁻¹	4500 min ⁻¹	5600 min ⁻¹	5100 min ⁻¹
WSTD	3500 min ⁻¹	3500 min ⁻¹	4950 min ⁻¹	5100 min ⁻¹
WBEMAX	3000 min ⁻¹	2800 min ⁻¹	2800 min ⁻¹	3500 min ⁻¹
CMAX	2700 min ⁻¹	2700 min ⁻¹	4400 min ⁻¹	5500 min ⁻¹
CSTD	2450 min ⁻¹	2450 min ⁻¹	4000 min ⁻¹	5500 min ⁻¹
CKYMAX_TY1	2200 min ⁻¹	2200 min ⁻¹	3500 min ⁻¹	3500 min ⁻¹
CJKMAX	1800 min ⁻¹	1800 min ⁻¹	2800 min ⁻¹	2700 min ⁻¹
CBEMAX	1600 min ⁻¹	1600 min ⁻¹	2200 min ⁻¹	2000 min ⁻¹
WMIN	1500 min ⁻¹	1500 min ⁻¹	1500 min ⁻¹	1800 min ⁻¹
CMIN	1500 min ⁻¹	1500 min ⁻¹	1500 min ⁻¹	1800 min ⁻¹
STARTMC	60 Seconds	60 Seconds	60 Seconds	60 Seconds
DWNRATEW	80%	80%	80%	80%
DWNRATEC	80%	80%	80%	80%
SHIFTW	5.00°C	5.00°C	5.00°C	5.00°C
SHIFTC	1.66°C	1.66°C	1.66°C	1.66°C
CLMXTP	30.00°C	30.00°C	30.00°C	30.00°C
YNEOF	20.00°C	20.00°C	20.00°C	20.00°C
TEION	0.00°C	0.00°C	0.00°C	0.00°C
TEIOF	9.00°C	9.00°C	9.00°C	9.00°C

Basic Cooling Operation

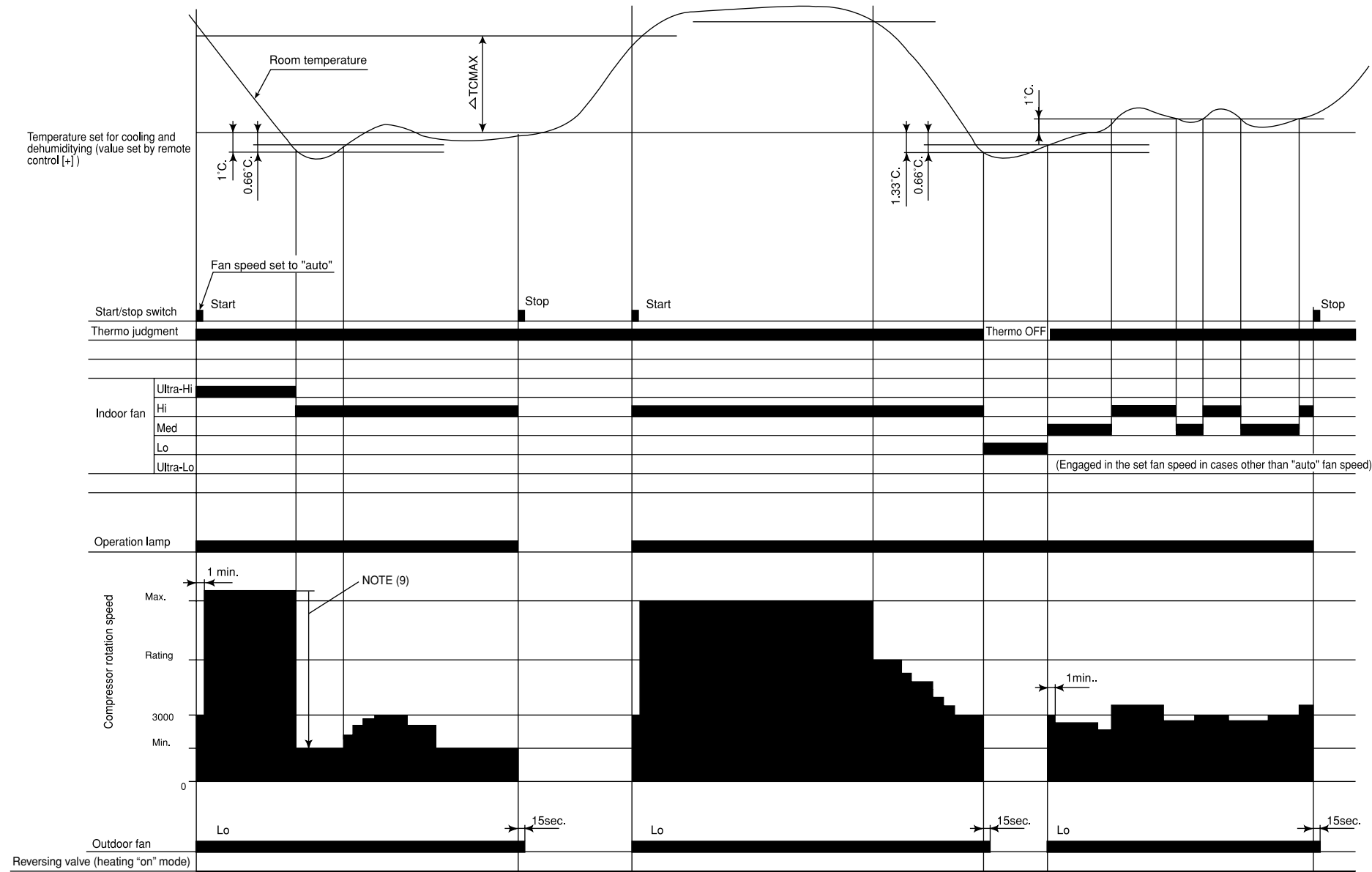

Notes:

- (1) Condition for entering into Cool Dashed mode. When fan set to “Hi” or “Auto mode” and temperature difference between indoor temperature and set temperature has a corresponding compressor rpm (calculated value in Table 7) larger than WMAX.
- (2) Cool Dashed will release when i) a maximum 25 minutes is lapsed and ii) room temperature is lower than set temperature -3°C (thermo off) and iii) when room temperature has achieved setting temperature -1°C then maximum Cool Dashed time will be revised to 20 minutes. And iv) indoor fan is set to Lo and Med fan mode and v) change operation mode.
- (3) During Cool Dashed operation, thermo off temperature is set temperature (with shift value) -3°C . After thermo off, operation continue in Fuzzy control mode.
- (4) Compressor minimum “ON” time and “OFF” time is 3 minutes.
- (5) During normal cooling mode, compressor maximum rpm CMAX will maintain for 60 minutes if indoor temperature is lower than CLMXTP. No time constrain if indoor temperature is higher than CLMXTP.
- (6) When fan is set to “Hi”, compressor rpm will be limited to CKYMAX-TY1.
- (7) When fan is set to “Med”, compressor rpm will be limited to CJKMAX.
- (8) When fan is set to “Lo”, compressor rpm will be limited to CBEMAX.
- (9) During Cool Dashed, when room temperature reaches set temperature -1°C compressor rpm is actual rpm x DWRATEC.

Table 2 ΔTCMAX

Temperature difference	Calculated compressor rpm
1.66	2265 min^{-1}
2	2435 min^{-1}
2.33	2600 min^{-1}
2.66	2765 min^{-1}
3	2935 min^{-1}
3.33	3100 min^{-1}
3.66	3265 min^{-1}
4	3435 min^{-1}
4.33	3600 min^{-1}
4.66	3765 min^{-1}
5	3935 min^{-1}
5.33	4100 min^{-1}
5.66	4265 min^{-1}
6	4435 min^{-1}
6.33	4600 min^{-1}
6.66	4765 min^{-1}
7	4935 min^{-1}
7.33	5100 min^{-1}
7.66	5265 min^{-1}
8	5435 min^{-1}
8.33	5600 min^{-1}
8.66	5765 min^{-1}
9	5935 min^{-1}
9.33	6100 min^{-1}
9.66	6265 min^{-1}
10	6435 min^{-1}
10.33	6600 min^{-1}
10.66	6765 min^{-1}
11	6935 min^{-1}

Note:

1. See the data in Table 1 on page 43 for each constant in capital letters in the diagrams.

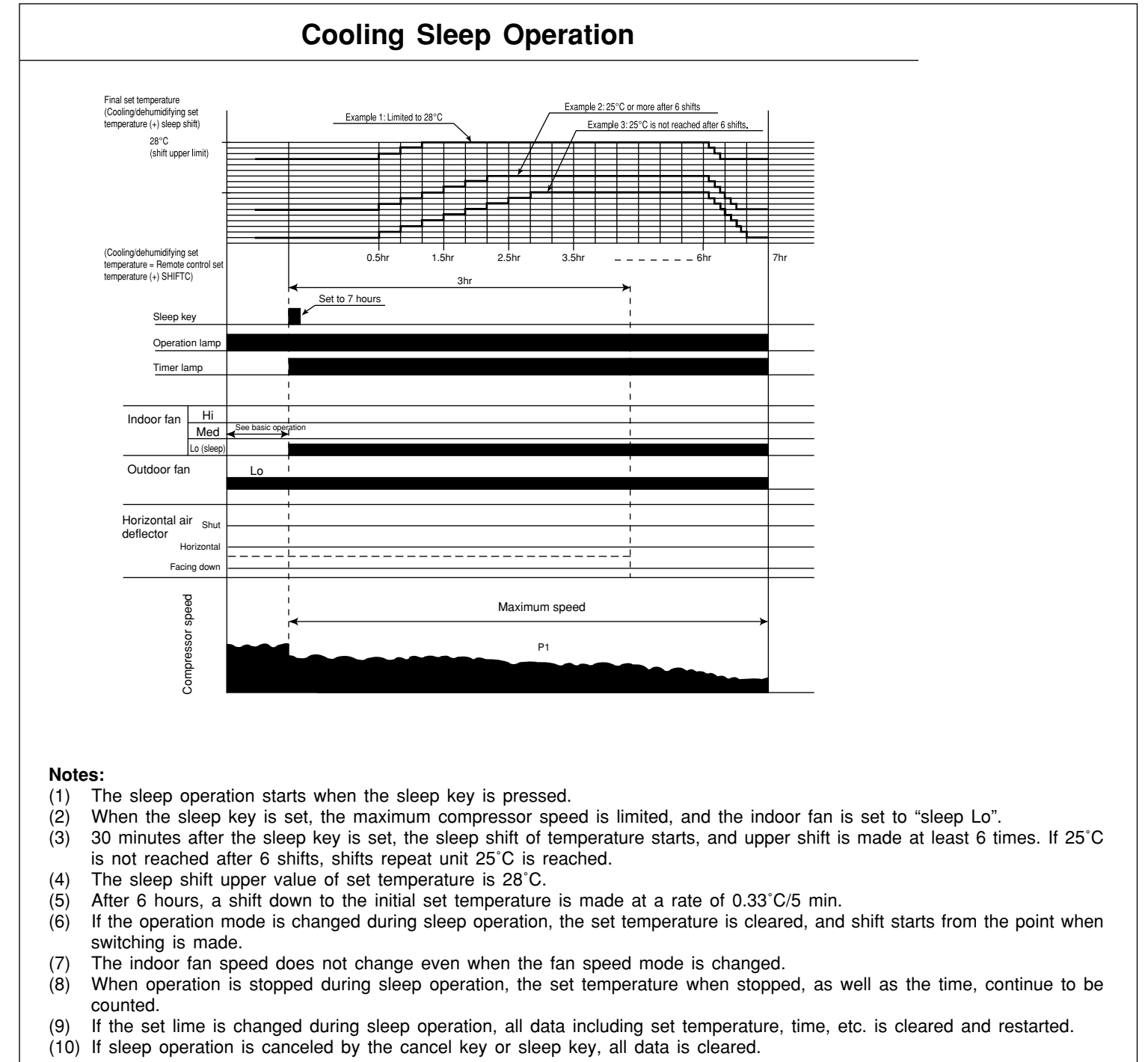
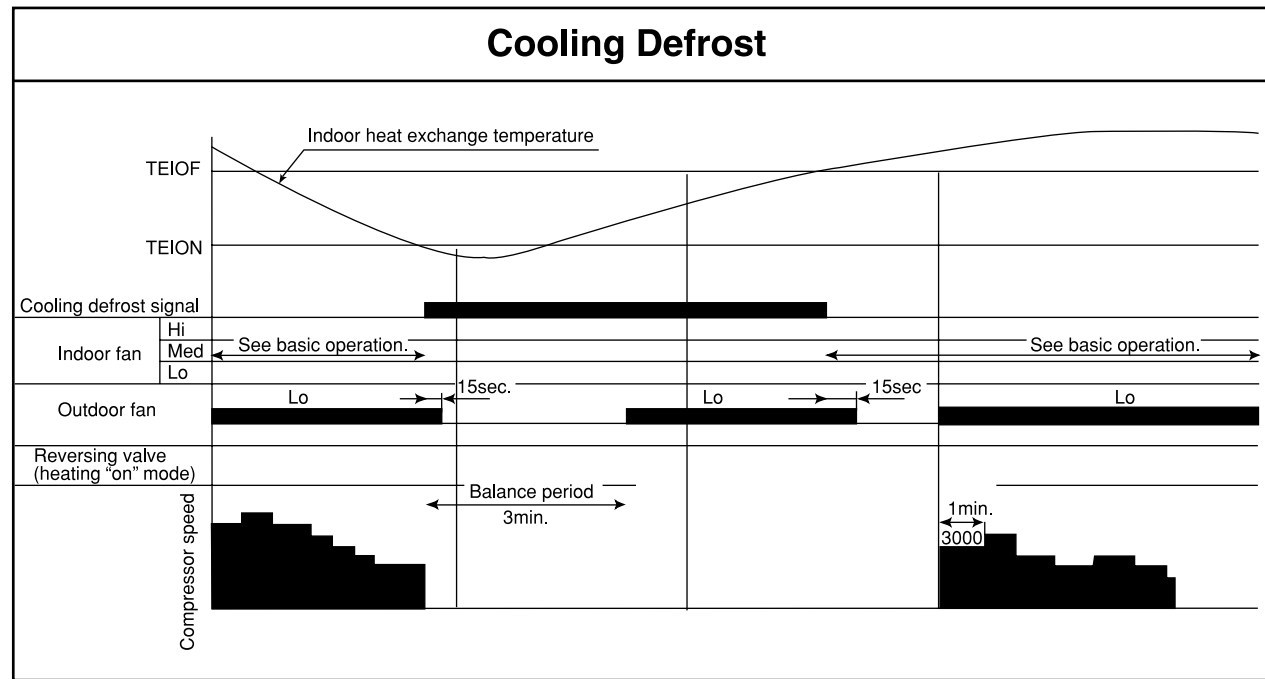

Notes:

- (1) The sleep operation starts when the sleep key is pressed.
- (2) When the sleep key is set, the maximum compressor speed is limited, and the indoor fan is set to "sleep Lo".
- (3) 30 minutes after the sleep key is set, the sleep shift of temperature starts, and upper shift is made at least 6 times. If 25°C is not reached after 6 shifts, shifts repeat until 25°C is reached.
- (4) The sleep shift upper value of set temperature is 28°C.
- (5) After 6 hours, a shift down to the initial set temperature is made at a rate of 0.33°C/5 min.
- (6) If the operation mode is changed during sleep operation, the set temperature is cleared, and shift starts from the point when switching is made.
- (7) The indoor fan speed does not change even when the fan speed mode is changed.
- (8) When operation is stopped during sleep operation, the set temperature when stopped, as well as the time, continue to be counted.
- (9) If the set time is changed during sleep operation, all data including set temperature, time, etc. is cleared and restarted.
- (10) If sleep operation is canceled by the cancel key or sleep key, all data is cleared.

Dehumidifying

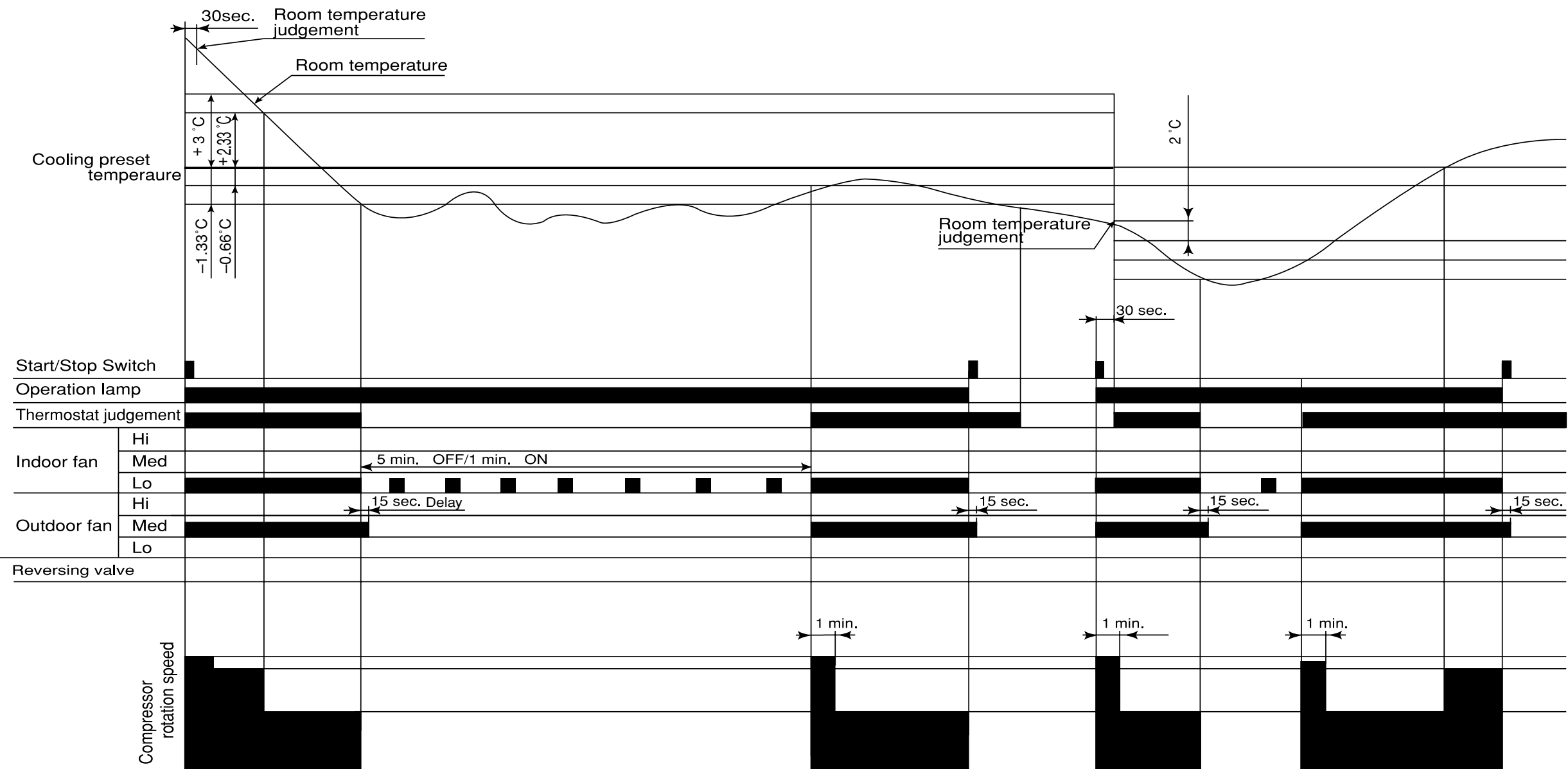

Notes:

- (1) If the room temperature is (cooling preset temperature) - (1.33°C) or less after 30 seconds from starting the operation, the operation is done assuming as the preset temperature = (room temperature at the time) - (2°C).
- (2) The indoor fan is operated in the "Lo" mode. During thermo OFF indoor fan will be OFF for 5 minutes and ON for 1 minute.
- (3) When the operation is started by the thermostat turning ON, the start of the indoor fan is delayed 32 seconds after the start of compressor operation.
- (4) The compressor is operated forcedly for 3 minutes after operation is started.
- (5) The minimum ON time and OFF time of the compressor are 3 minutes.

Basic Heating Operation

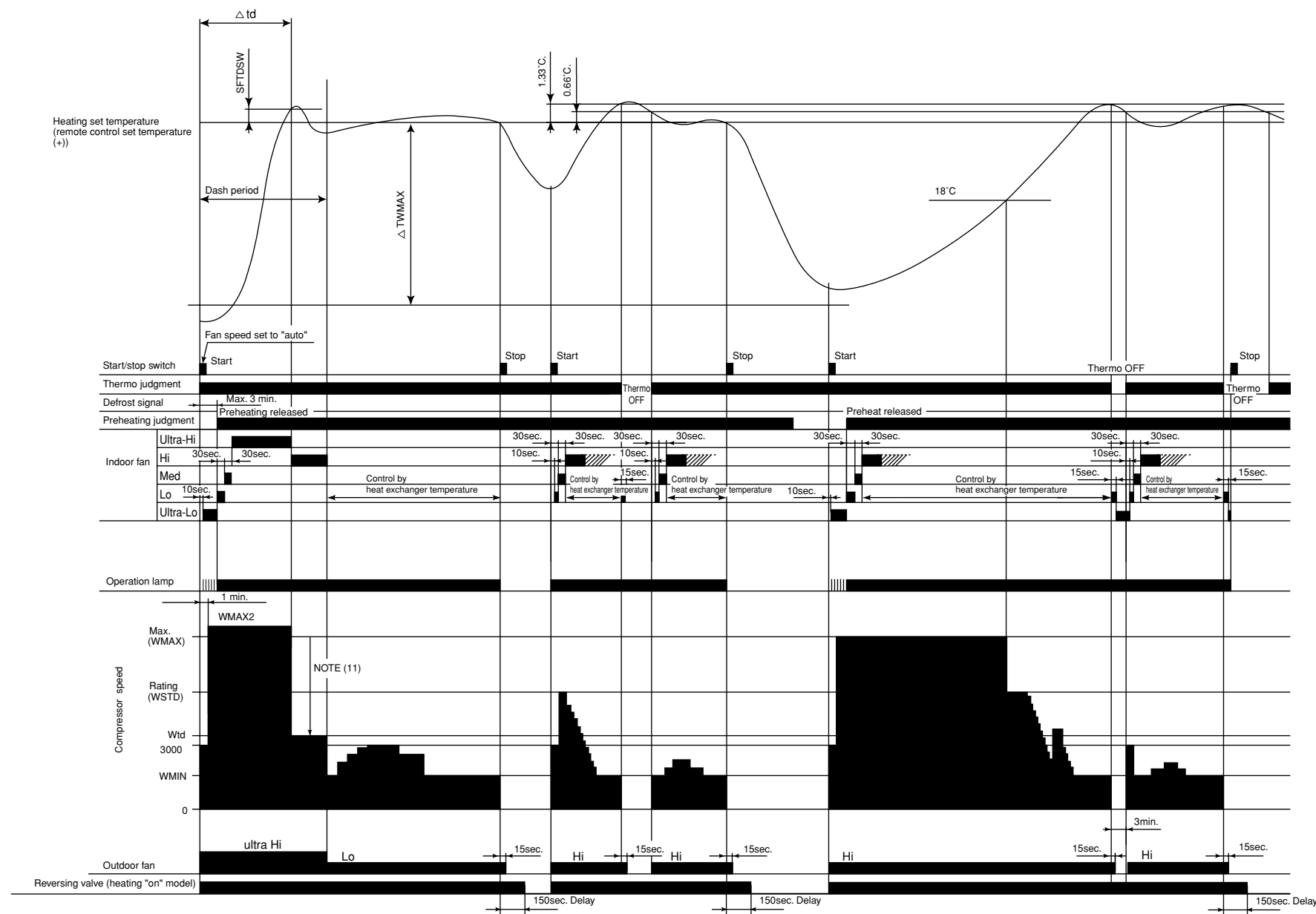

Notes:

- (1) Condition for entering into Hot Dashed mode. When fan set to "Hi" or "Auto mode" and i) Indoor temperature is lower than 18°C, and ii) outdoor temperature is lower than 10°C, and iii) Temperature difference between indoor temperature and set temperature has a corresponding compressor rpm (calculated value in Table 3) larger than WMAX.
- (2) Hot Dashed will release when i) Room temperature has achieved the set temperature + SFTDSW. ii) Thermo off.
- (3) During Hot Dashed operation, thermo off temperature is set temperature (with shift value) +3°C. After thermo off, operation continue in Fuzzy control mode.
- (4) Compressor minimum "ON" time and "OFF" time is 3 minutes.
- (5) During normal heating mode, compressor maximum rpm WMAX will maintain for 120 minutes if indoor temperature is higher than 18°C. No time limit constrain if indoor temperature is lower than 18°C and outdoor temperature is lower than 2°C.
- (6) During Hotkeep or Defrost mode, indoor operation lamp will blink at interval of 3 seconds "ON" and 0.5 second "OFF".
- (7) When heating mode starts, it will enter into Hotkeep mode if indoor heat exchanger temperature is lower than YNEOF + 0.33°C.
- (8) When fan is set to "Med" or "Lo", compressor rpm will be limited to WBEMAX.
- (9) In "Ultra-Lo" fan mode, if indoor temperature is lower than 18°C, indoor fan will stop. If indoor temperature is higher than 18°C + 0.33°C, fan will continue in "Ultra-Lo" mode. During Hotkeep or Defrost mode, fan will continue in "Ultra-Lo" mode.
- (10) During Hot Dashed or outdoor temperature is lower than -5°C, compressor rpm is WMAX2.
- (11) During Hot Dashed, when room temperature reaches set temperature + SFTDSW compressor rpm is actual rpm x DWNRATEW.

Table 3 ΔTWMAX

Temperature difference	Calculated compressor rpm
1.66	1965 min ⁻¹
2	2135 min ⁻¹
2.33	2300 min ⁻¹
2.66	2465 min ⁻¹
3	2635 min ⁻¹
3.33	2800 min ⁻¹
3.66	2965 min ⁻¹
4	3135 min ⁻¹
4.33	3300 min ⁻¹
4.66	3465 min ⁻¹
5	3635 min ⁻¹
5.33	3800 min ⁻¹
5.66	3965 min ⁻¹
6	4135 min ⁻¹
6.33	4300 min ⁻¹
6.66	4465 min ⁻¹
7	4635 min ⁻¹
7.33	4800 min ⁻¹
7.66	4965 min ⁻¹
8	5135 min ⁻¹
8.33	5300 min ⁻¹
8.66	5465 min ⁻¹
9	5635 min ⁻¹
9.33	5800 min ⁻¹
9.66	5965 min ⁻¹
10	6135 min ⁻¹
10.33	6300 min ⁻¹
10.66	6465 min ⁻¹
11	6635 min ⁻¹

Notes:

1. See the data in Table 1 on page 43 for each constant in capital letters in the diagrams.

Reversing Valve Defrosting

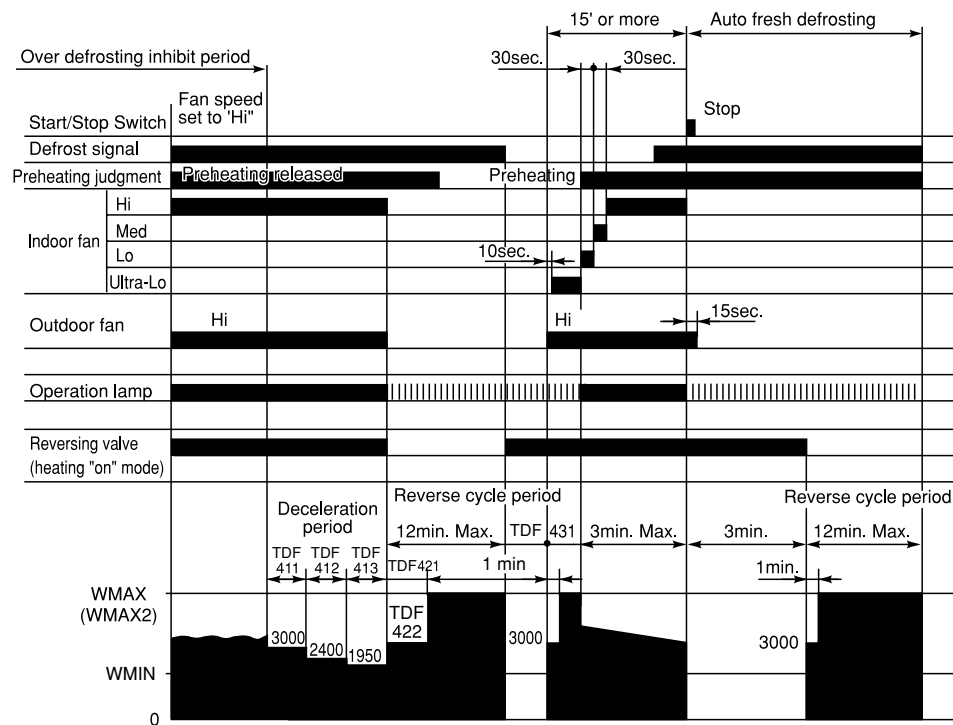

Notes:

- (1) The defrosting inhibit period is set as shown in the diagram below. When defrosting has finished once, the inhibit period is newly set, based on the outdoor temperature when the compressor was started. During this period, the defrost signal is not accepted.
- (2) If the difference between the room and outdoor temperature is large when defrosting is finished, the maximum compressor speed (WMAX) or (WMAX2) can be continued for 120 minutes maximum.
- (3) The defrosting period is 12 minutes maximum.
- (4) When operation is stopped during defrosting, it is switched to auto refresh defrosting.
- (5) Auto refresh defrosting cannot be engaged within 15 minutes after operation is started or defrosting is finished.

Setting Defrosting Inhibit Period

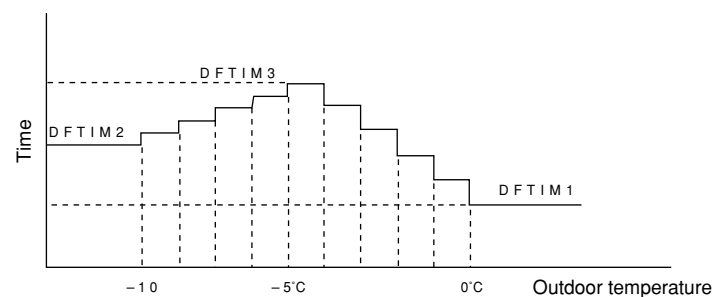

Notes:

- (1) The first inhibit time after operation start is set to DFTIM1.
- (2) From the second time onwards, the inhibit time is set according to the time required for defrosting.
Reverse cycle operation time \geq [DEFCOL] : DFTIM1 is set.
Reverse cycle operation time $<$ [DEFCOL] : The time corresponding to outdoor temperature is set.

Heating Sleep Operation

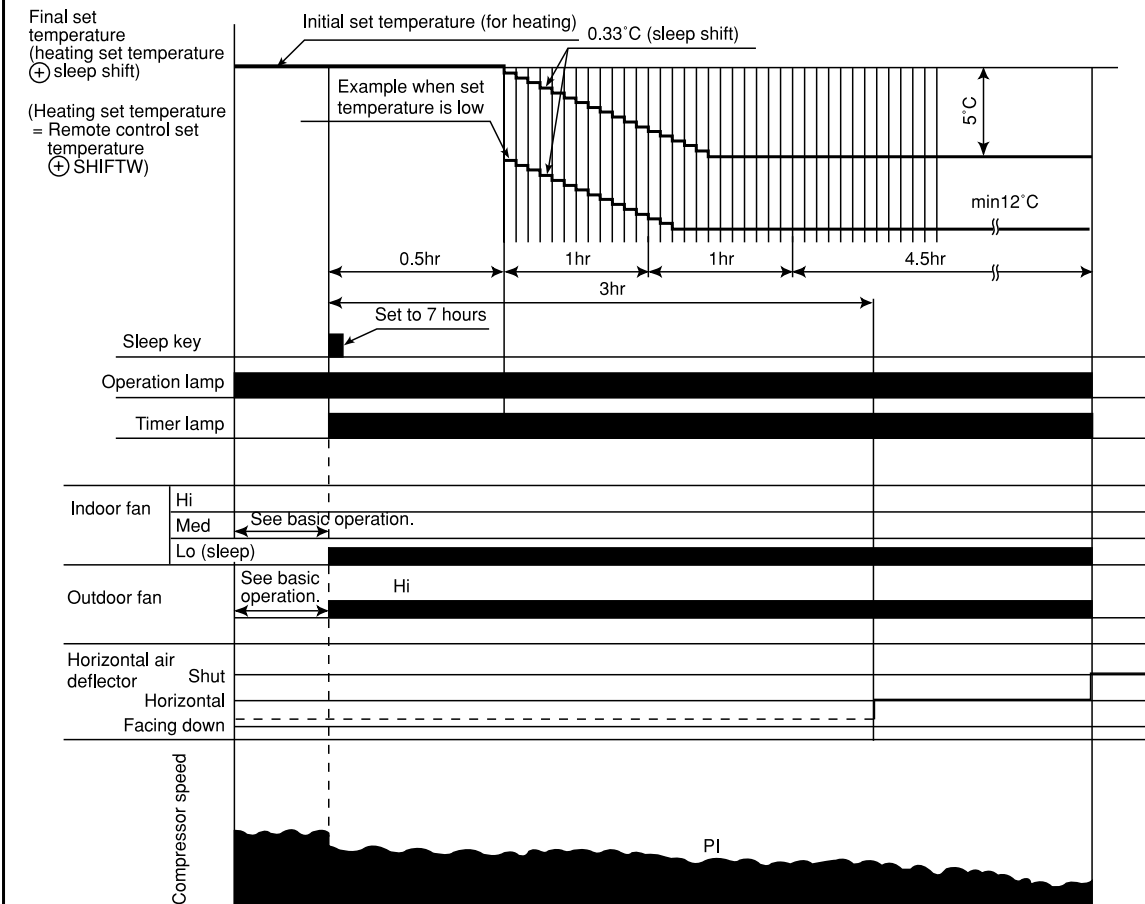

Notes:

- (1) The sleep operation starts when the sleep key is pressed.
- (2) When the sleep key is set, the maximum compressor speed is limited to WSTD+2000/2, and the indoor fan is set to "sleep Lo".
- (3) 30 minutes after the sleep key is set, the sleep shift of set temperature starts.
- (4) The maximum sleep shift of set temperature is 5°C, and the minimum is 12°C.
- (5) If the operation mode is changed during sleep operation, the changed operation mode is set and sleep control starts.
- (6) The indoor fan speed does not change even when the fan speed mode is changed. (Lo)
- (7) When defrosting is to be set during sleep operation, defrosting is engaged and sleep operation is restored after defrosting.
- (8) When operation is stopped during sleep operation, the set temperature when stopped, as well as the time, continue to be counted.
- (9) If the set time is changed during sleep operation, all data including set temperature, time, etc. is cleared and restarted.
- (10) If sleep operation is canceled by the cancel key or sleep key, all data is cleared.

REFRIGERATING CYCLE DIAGRAM

MODEL RAD-18NH7A

RAD-25NH7A/RAC-25NH5

RAD-35NH7A/RAC-35NH5

COOLING, DEHUMIDIFYING, DEFROSTING

OUTDOOR UNIT

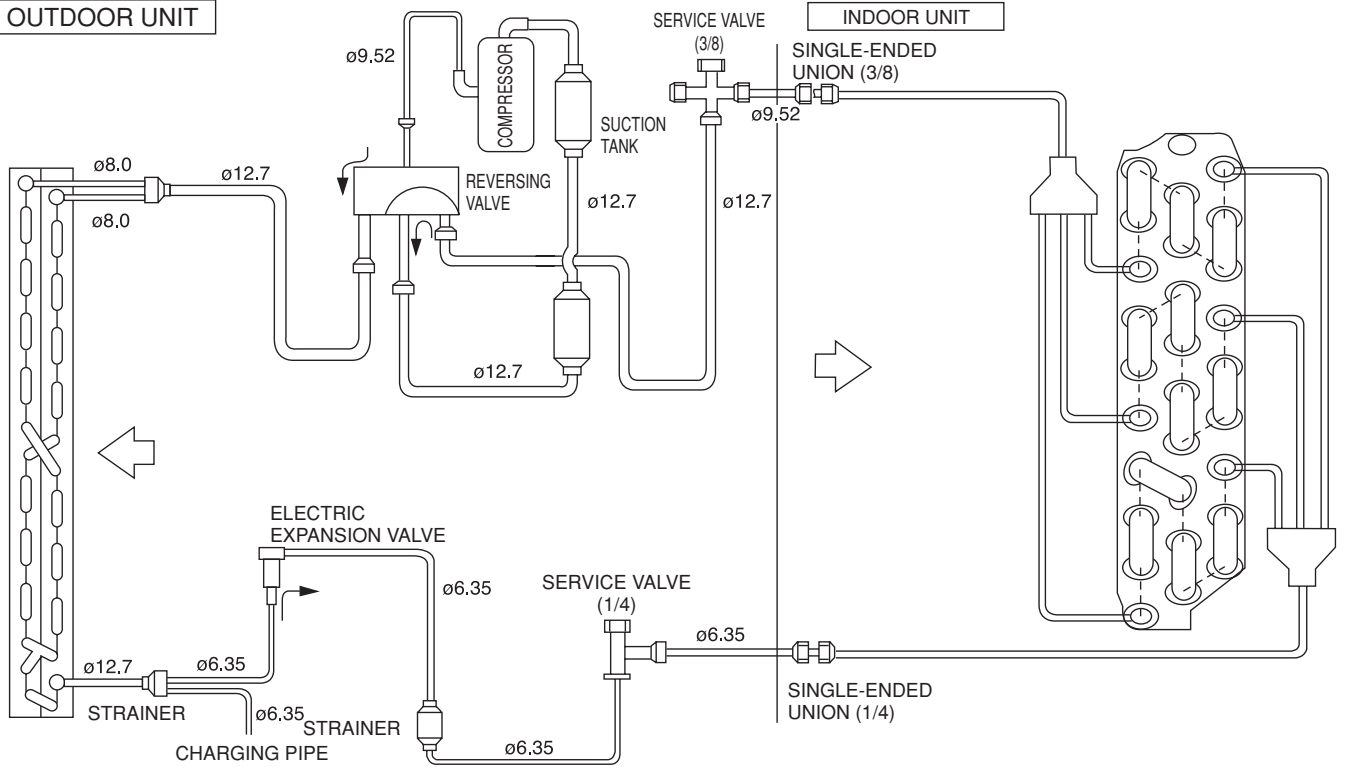

HEATING

OUTDOOR UNIT

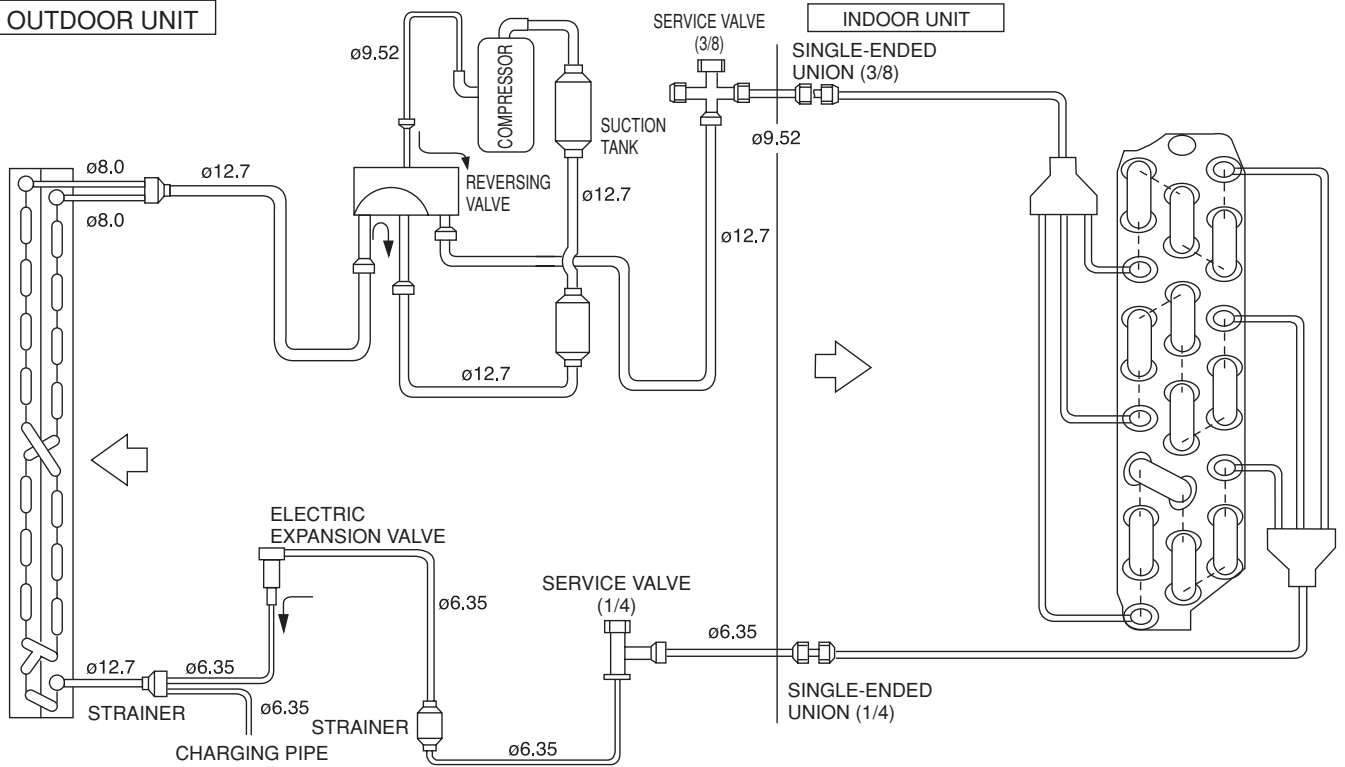

REFRIGERATING CYCLE DIAGRAM

MODEL RAD-50NH7A

RAC-50NH5

COOLING, DEHUMIDIFYING, DEFROSTING

OUTDOOR UNIT

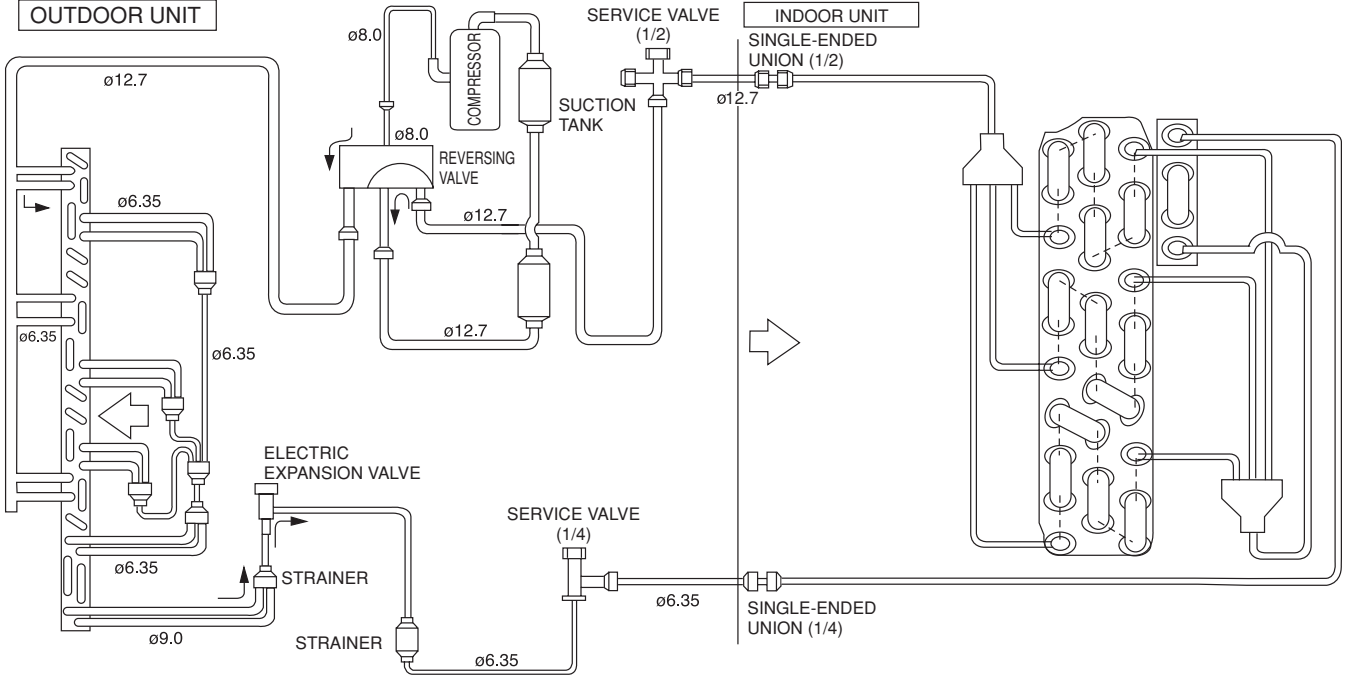

HEATING

OUTDOOR UNIT

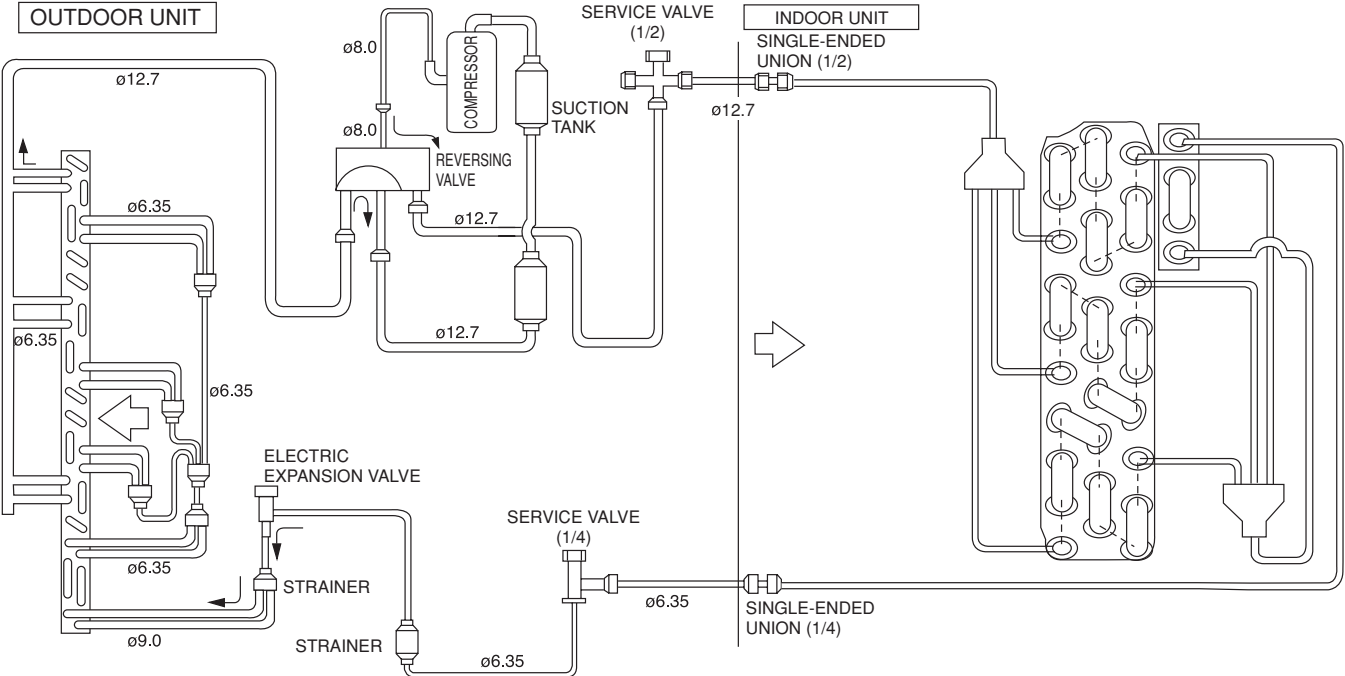

1. Receiver Circuit

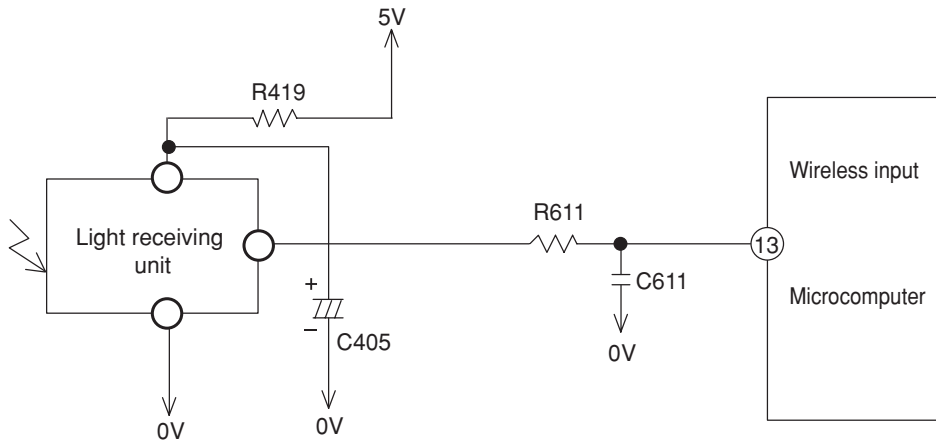

Fig. 1-1

- The light receiver unit receives the infrared signal from the wireless remote control (option part). The receiver amplifies and shapes the signal and outputs it.

2. Buzzer Circuit

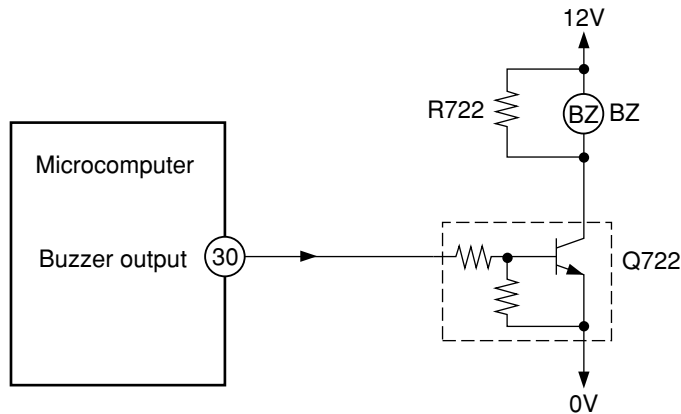

Fig. 2-1 Buzzer Circuit

- When the buzzer sounds, an approx. 3.9kHz square signal is output from buzzer output pin (30) of the microcomputer. After the amplitude of this signal has been set to 12Vp-p by a transistor, it is applied to the buzzer. The piezoelectric element in the buzzer oscillates to generate the buzzer's sound.

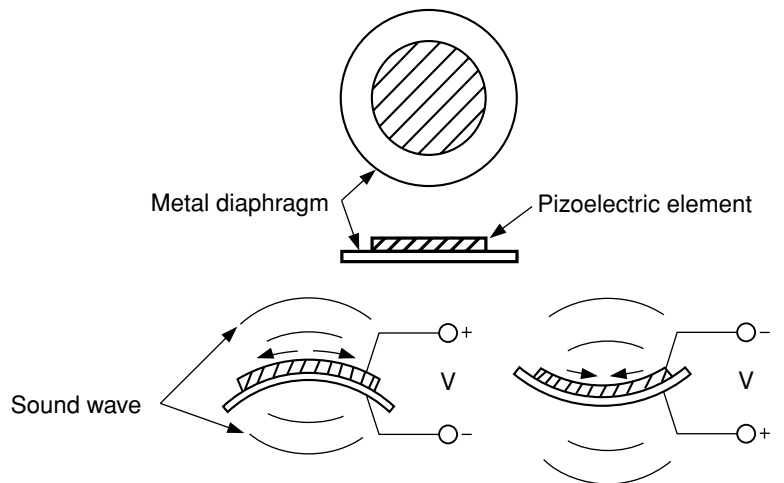
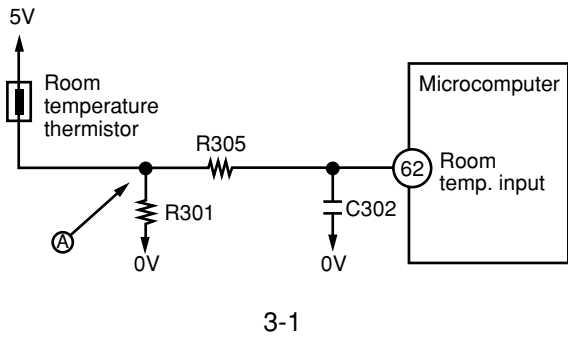

Fig. 2-2 Buzzer Operation

3. Room Temperature Thermistor Circuit

- Fig. 3-1 shows the room temperature thermistor circuit.



- The voltage at (A) depends on the room temperature as shown in Fig. 4-2.

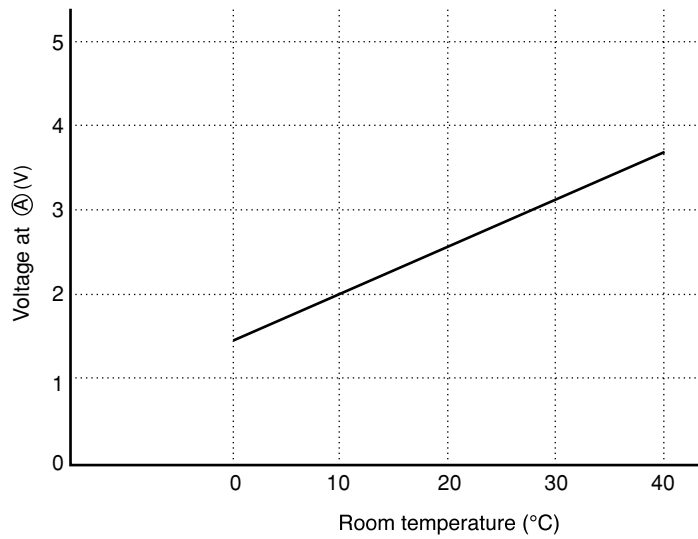

Fig. 3-2

4. Heat exchanger temperature thermistor circuit

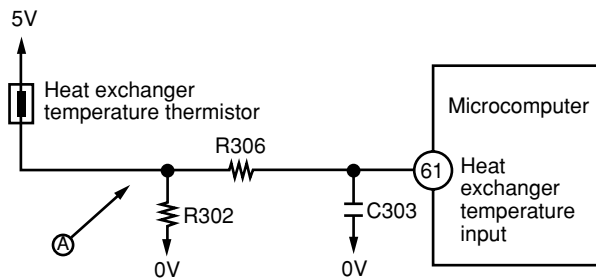

Fig. 4-1

- The circuit detects the indoor heat exchanger temperature and controls the following.

- (1) Preheating.
- (2) Low-temperature defrosting during cooling and dehumidifying operation.
- (3) Detection of the reversing valve non-operation or heat exchanger temperature thermistor open.

The voltage at (A) depends on the heat exchanger temperature as shown in Fig. 4-2.

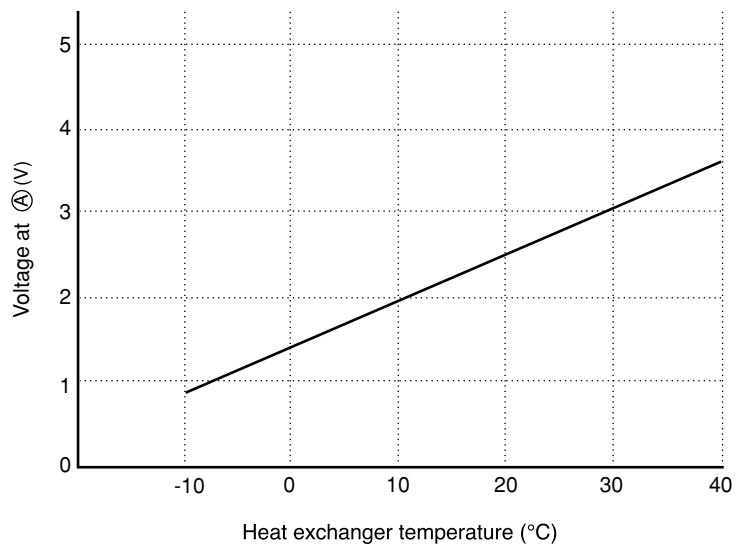

Fig. 4-2

5. Initial Setting Circuit (IC401)

- When power is supplied, the microcomputer reads the data in IC401 (E²PROM) and sets the preheating activation value and the rating and maximum speed of the compressor, etc. to their initial values.
- Data of self-diagnosis mode is stored in IC401; data will not be erased even when power is turned off.

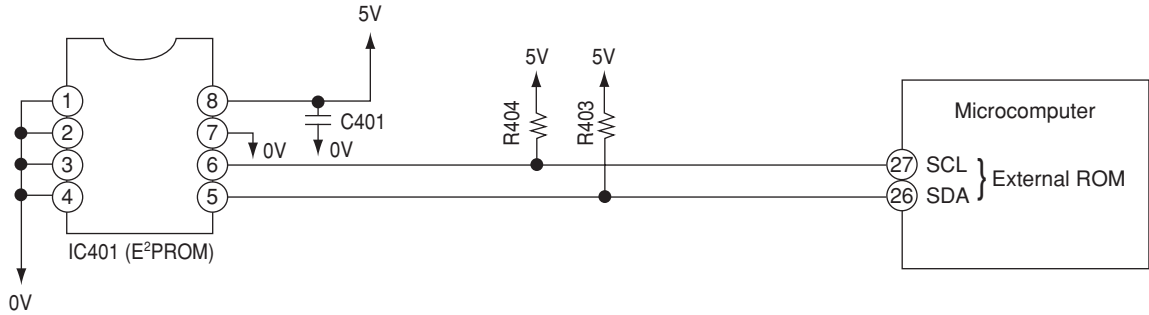

Fig. 5-1

6. Temporary Switch

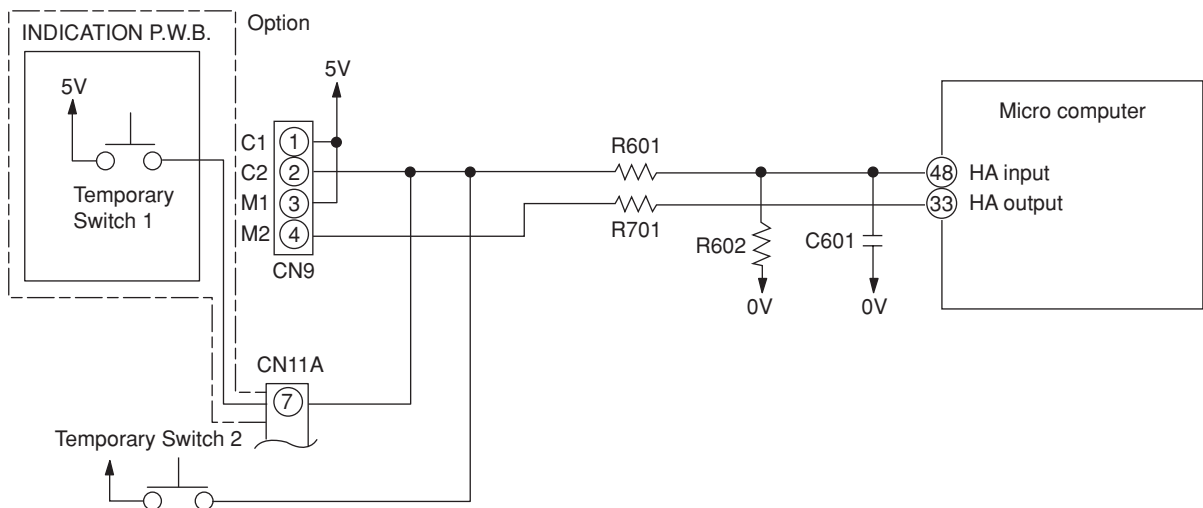

Fig. 6-1

- The temporary switch is used to operate the air conditioner temporarily when the wireless remote control is lost or faulty.

7. Drain pump drive circuit

When cool or dehumidifying operation, pin ⑤⑧ of the micro computer goes “Hi”, Q933 and Q932 turn on and the drain pump drive.

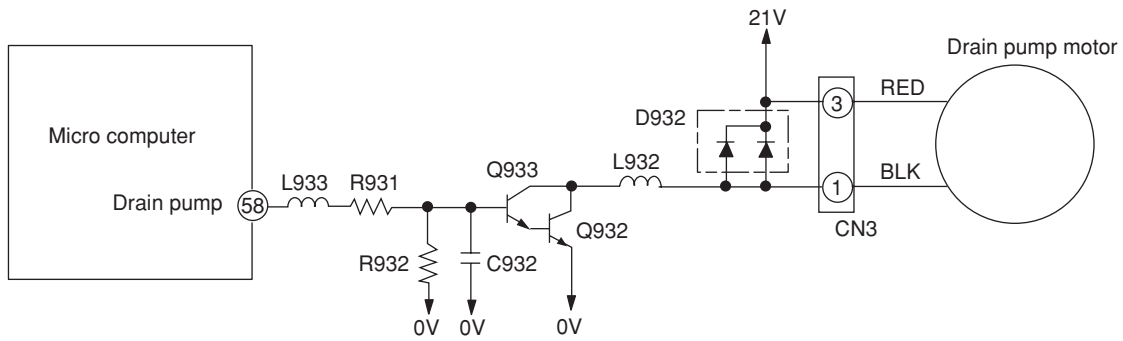
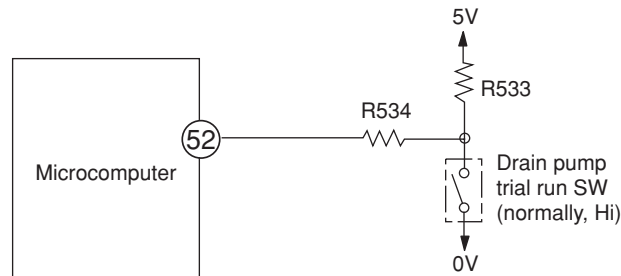

Fig. 7-1

8. Drain pump trial run switch



- This switch forcibly turns the drain pump on. When the drain pump trial run switch is turned on, the timer indicator will blink seven times, and no remote signal will be accepted.

9. Float switch

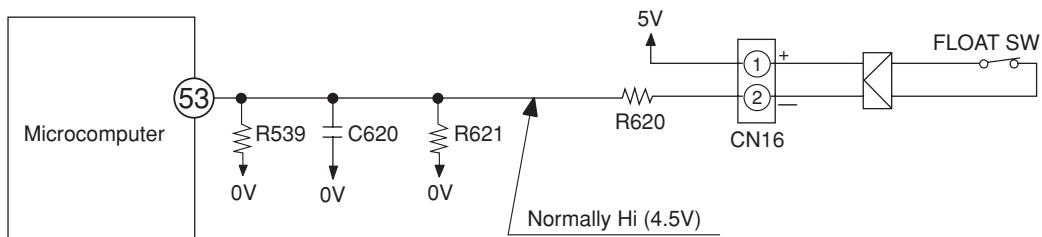

- This is a float type switch that monitors the drain level of drain pan. The switch will be activated and will stop operation if the drain pump is faulty or drain hose is stopped up, disabling drainage, causing the drain level to rise abnormally.
- When the float switch is activated, the timer indicator will flash six times. Note that the float switch will also be activated, disabling operation if the connector of float switch has defective contact or is connected incompletely.

10. High static-pressure switch (Full duct type and semi duct type)

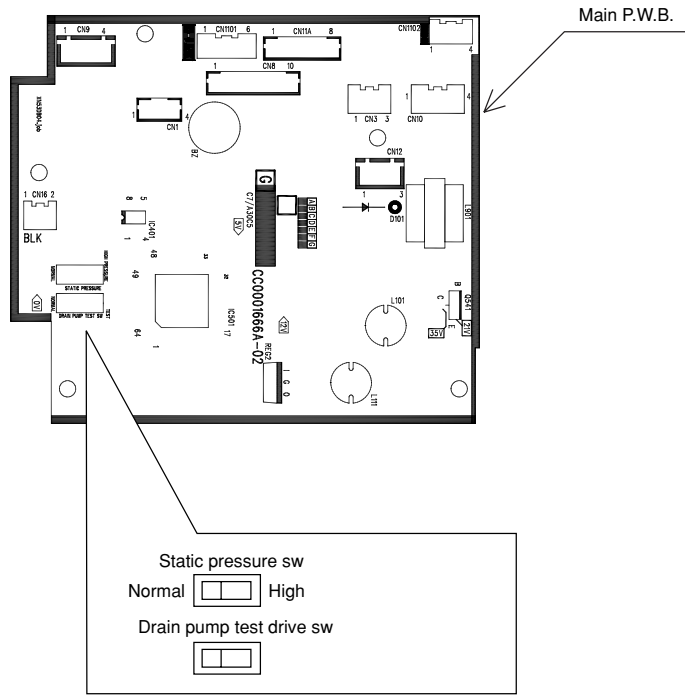
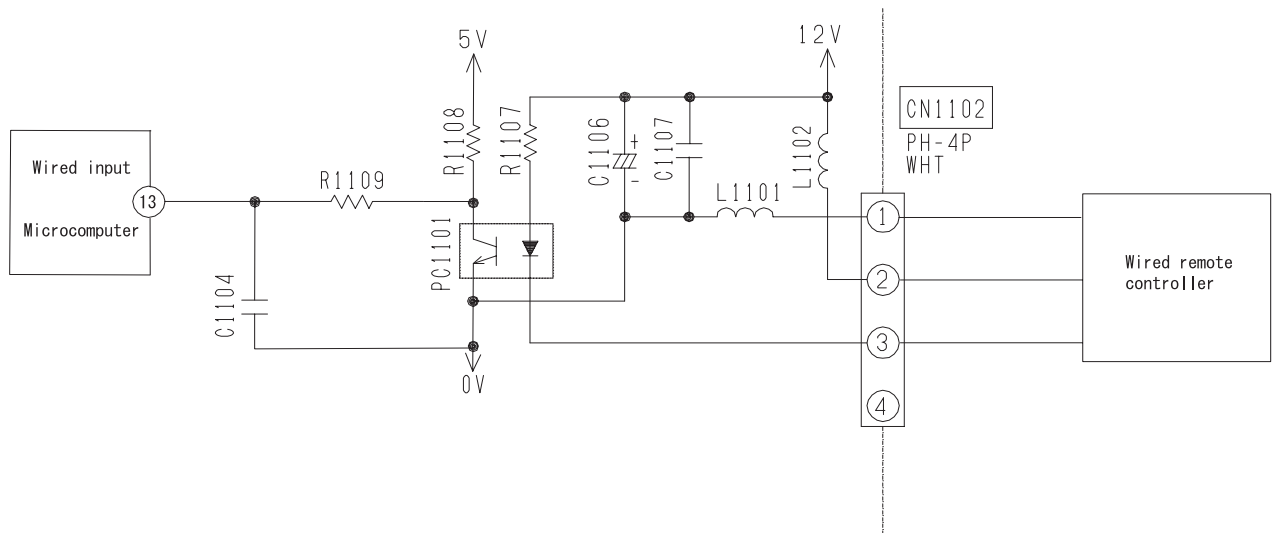

Fig. 10-1

- For full duct type and semi duct type, set the high to HIGH STATIC-PRESSURE.
- If not set to HIGH, there will be reduction of cooling and heating capacities.

11. Wired remote control receiver circuit



- In wired remote control receiver circuit, the signal will transmit to micro computer pin 3 by using photocoupler PC101.

Model RAC-25NH5, RAC-35NH5, RAC-50NH5

1. Power Circuit

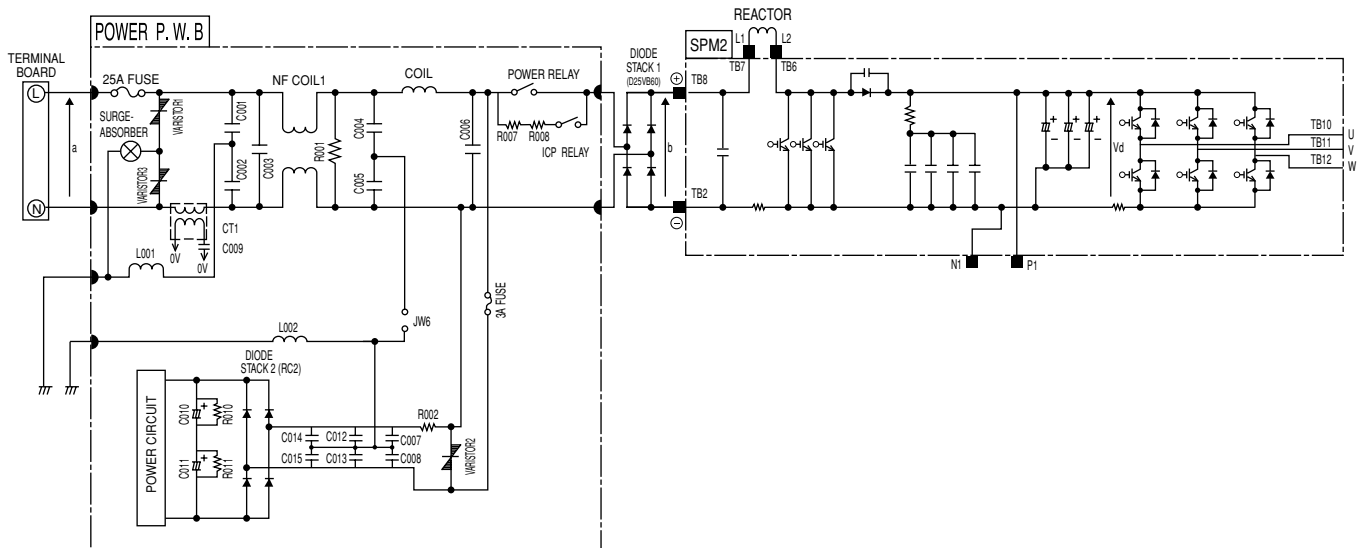

Fig. 1-1

- This circuit full-wave rectifies 220-240V AC applied between terminals L and N, and boosts it to a required voltage with the active module, to create a DC voltage.

The voltage becomes 260-360V when the compressor is operated

(1) Active module

The active filter, consisting of a reactor and switching element, eliminates higher harmonic components contained in the current generated when the compressor is operated, and improves the power-factor.

(2) Diode stacks

These rectify the 220-240V AC from terminals L and N to a DC power supply.

< Reference >

- In case of malfunction or defective connection: Immediately after the compressor starts, it may stop due to “abnormally low speed” active error, etc.

The compressor may continue to operate normally, but the power-factor will decrease, the operation current will increase, and the overcurrent breaker of the household power board will probably activate.

- In case of active module faulty or defective connection:

Although the compressor continues to operate normally, the power-factor will decrease, the operation current will increase, and the overcurrent breaker of the household power board will probably activate.

< Reference >

- If diode stack 1 is faulty, the compressor may stop due to “lp”, “abnormally low speed”, etc. immediately after it starts, or it may not operate at all because no DC voltage is generated between the positive ⊕ and negative ⊖ terminals.

If diode stack 1 is faulty, be aware that the 25A fuse might also have blown.

- If diode stack 2 is faulty, DC voltage may not be generated and the compressor may not operate at all. Also, be aware that the 3A fuse might have blown.

(3) Smoothing capacitor (C501, C502, C503)

This smoothes (averages) the voltage rectified by the diode stacks.

<Notes> Smoothing capacitor C501 is not available for model RAC-25NH5 and RAC-35NH5.

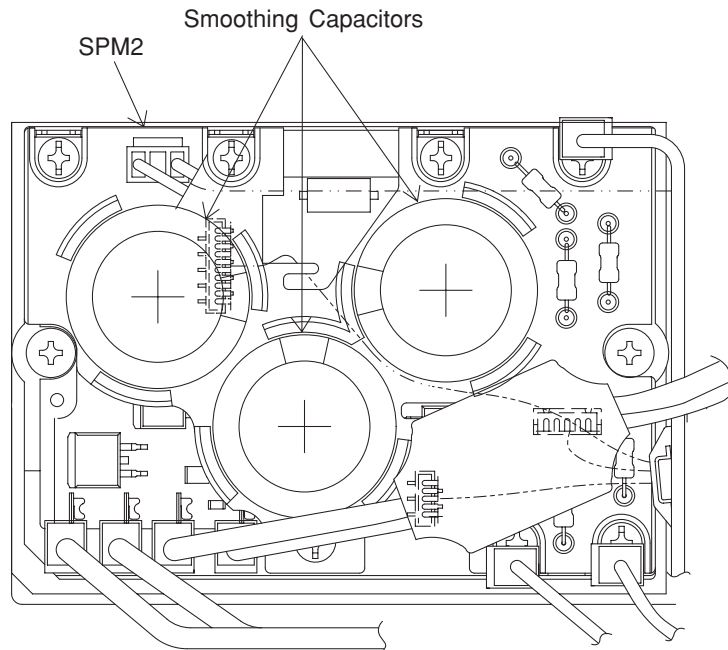

Fig. 1-2

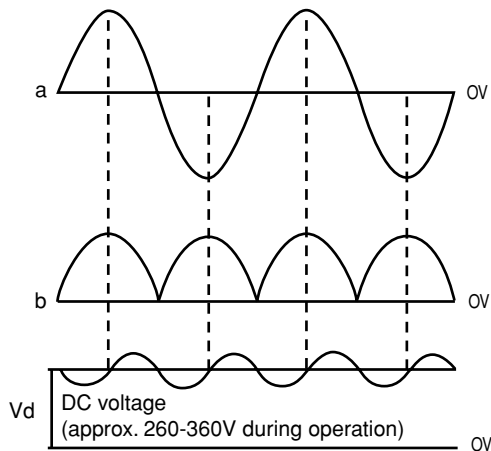

Fig. 1-3

- Be careful to avoid an electric shock as a high voltage is generated. Also take care not to cause a short-circuit through incorrect connection of test equipment terminals. The circuit board could be damaged.

(4) Smoothing capacitor (C010, C011)

This smoothes (averages) the voltage rectified by the diode stack2. A DC voltage is generated in the same way as in Fig. 1-3.

Voltage between + side of C010 and – side of C011 is about 330V.

(5) C001 to C003, C012 to C015, C007, C008, NF COIL1, COIL, absorb electrical noise generated during operation of compressor, and also absorb external noise entering from power line to protect electronic parts.

(6) Surge absorber, Varistor 1, 2, 3, absorbs external power surge.

(7) Inrush protective resistor (R007, R008)

This works to protect from overcurrent when power is turned on.

< Reference >

- When inrush protective resistor is defective, diode stack may malfunction. As a result, DC voltage is not generated and no operation can be done.

2. Indoor/Outdoor Interface Circuit

- The interface circuit superimposes an interface signal on the DC 35V line supplied from the outdoor unit to perform communications between indoor and outdoor units. This circuit consists of a transmitting circuit which superimposes an interface signal transmit from the microcomputer on the DC 35V line and a transmitting circuit which detects the interface signal on the DC 35V line and outputs it to the microcomputer.
- Communications are performed by mutually transmitting and receiving the 4-frame outdoor request signal one frame of which consists of a leader of approx. 100 ms., start bit, 8-bit data and stop bit and the command signal with the same format transmit from the indoor unit.
- Communication signal from outdoor microcomputer to indoor microcomputer. At first outdoor microcomputer will send a request signal (SDO) to indoor microcomputer. A high-frequency IF signal approx. 38 KHz is generated and modulated by the request signal (SDO) inside the outdoor microcomputer then output to pin (11) of microcomputer. This modulated IF signal is output to pin (30) of HIC and amplified by amp. This signal is superimposed to DC 35V line via C801 and L801.
To prevent erroneous reception, the outdoor microcomputer is designed so that it cannot receive a signal while it is outputting a request signal.
The receiving circuit in the indoor unit consists of a comparator and transistor. The interface signal from the outdoor unit on the DC 35V line is supplied to C821, where DC components are eliminated, and is then shaped by the comparator. The shaped signal is detected by diode, amplified by amp, and output to pin (49) of the indoor microcomputer.
Fig. 2-2 shows the voltages at each component when data is transferred from the outdoor microcomputer to the indoor microcomputer.
- Communication signal from indoor microcomputer to outdoor microcomputer. The request signal (SDO) generates by indoor microcomputer is output to pin (50), and amplifies by C801. IF signal approx. 38 kHz is generated by comparator, then modulate by the request signal from pin (50) of indoor microprocessor. This modulated IF signal is then amplified and superimposed to DC 35V line via L801 and C802 of indoor interface circuit.
Fig. 2-3 shows the voltages at each component when data is transferred from outdoor microcomputer to indoor microcomputer.
The circuit operation of the outdoor receiving circuit is same as indoor receiving circuit.

- Fig. 2-1 shows the interface circuit used for the indoor and outdoor microcomputers to communicate with each other.

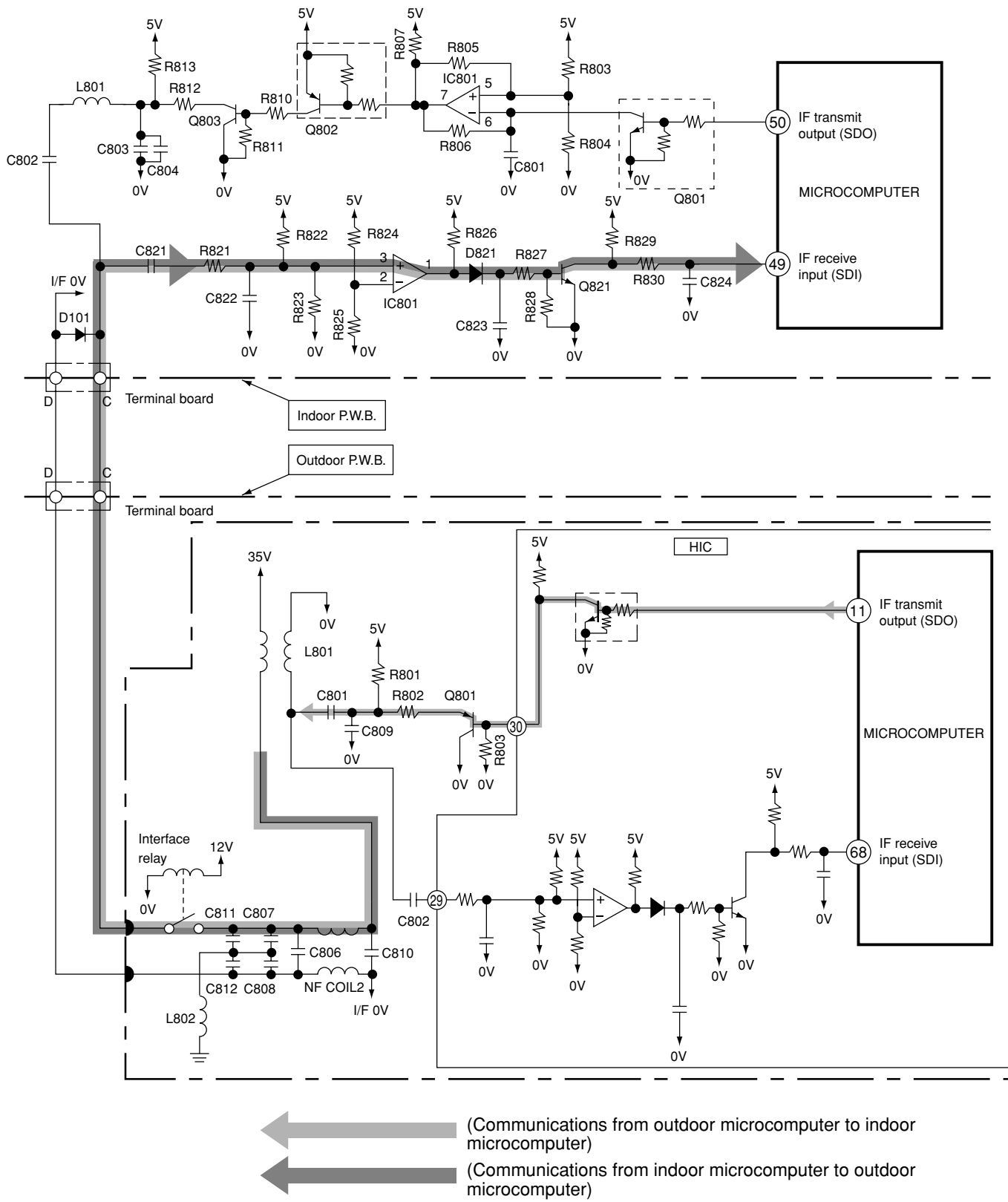

Fig. 2-1 Indoor/outdoor interface Circuit

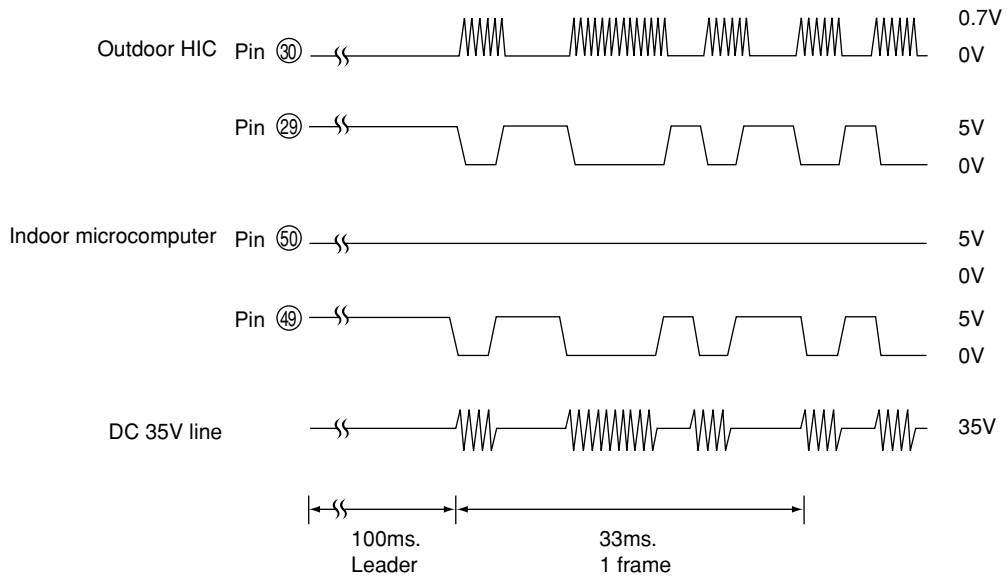

Fig. 2-2 Voltages Waveforms of indoor / Outdoor Microcomputers (Outdoor to Indoor Communications)

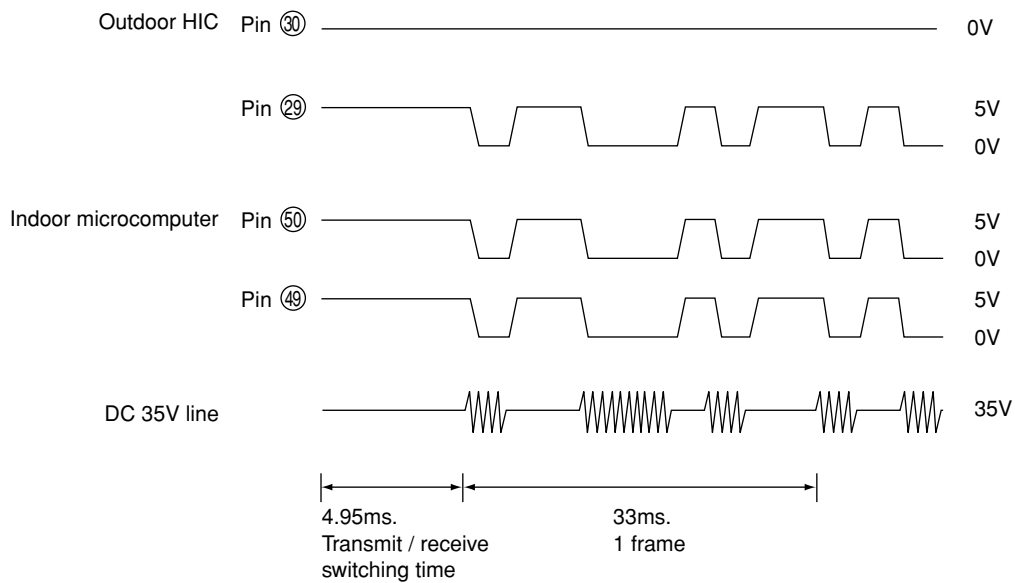
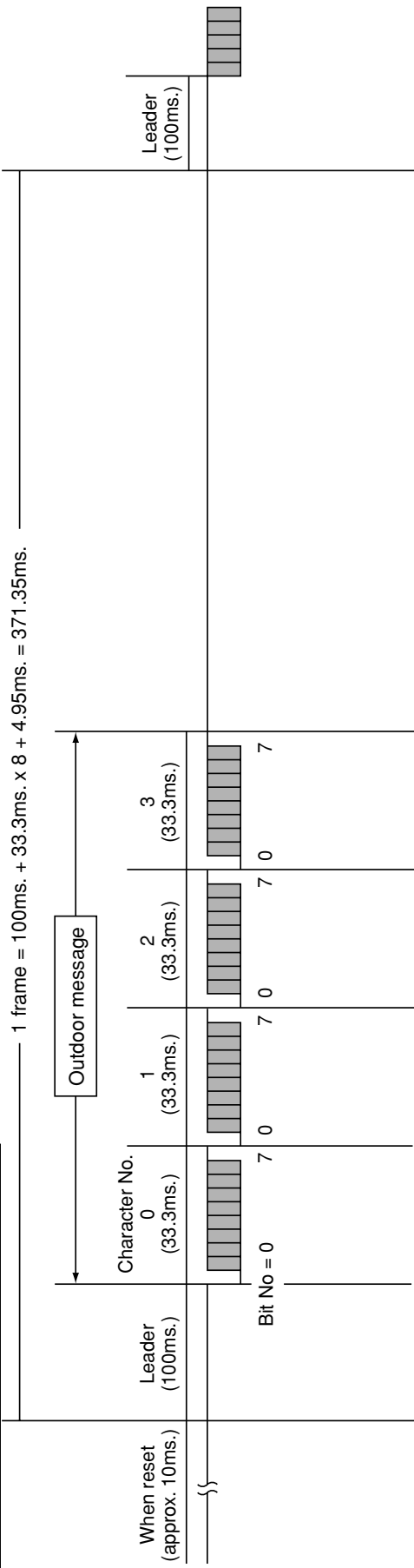

Fig. 2-3 Voltages Waveforms of indoor / Outdoor Microcomputers (Indoor to Outdoor Communications)

[Serial Communications Format during Normal Communications]

(1) Outdoor microcomputer (HIC) to indoor microcomputer



(2) Indoor microcomputer to outdoor microcomputer (HIC)

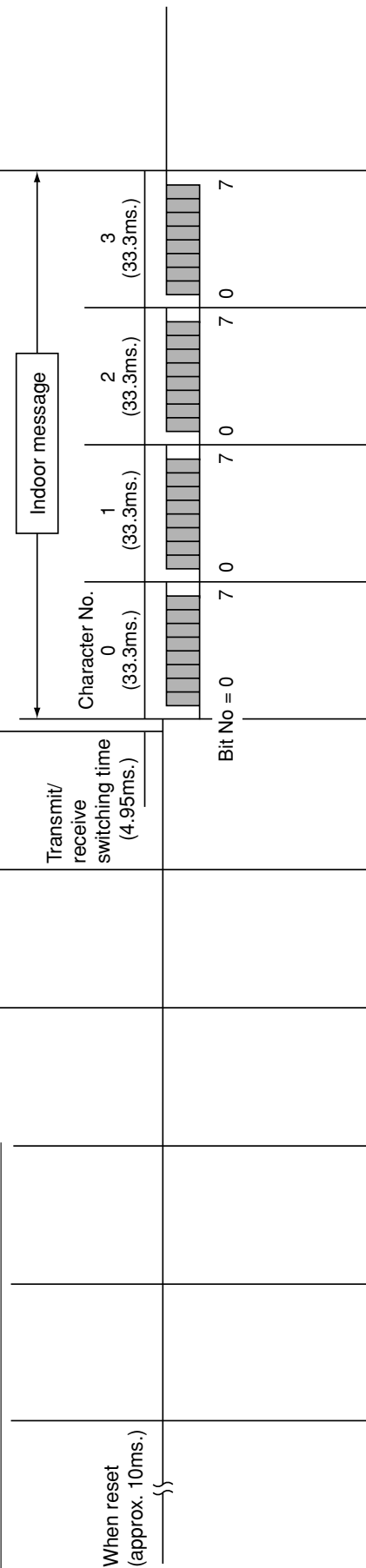

(3) Communications waveforms

[Example] When the outdoor message is all 0s and indoor message is all 1s:

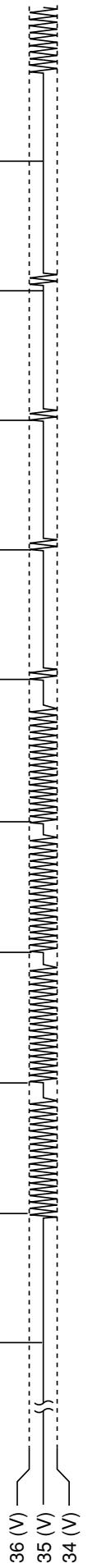

Fig. 2-4

[Serial Communications Data]

(1) Outdoor message

Character No.	0								1							2							3									
	Bit No.	7	6	5	4	3	2	1	0	1	2	3	4	5	6	7	0	1	2	3	4	5	6	7	0	1	2	3	4	5	6	7
	Multi-bit	1/0	0	0	1/0	1/0	1/0	1/0	0	1/0	1/0	1/0	1/0	1/0	1/0	1/0	0	1/0	1/0	1/0	1/0	1/0	1/0	1/0	0	1/0	1/0	1/0	1/0	1/0	1/0	1/0
	Contents	During forced operation								Outside temperature (0 LSB)							Compressor during operation							Actual compressor rotation speed (0 LSB)								
		Defrost request signal								Outside temperature (1)							Compressor during operation							Actual compressor rotation speed (1)								
		Self-diagnosis (0 LSB)								Outside temperature (2)							Compressor during operation							Actual compressor rotation speed (2)								
		Self-diagnosis (1)								Outside temperature (3)							Compressor during operation							Actual compressor rotation speed (3)								
		Self-diagnosis (2)								Outside temperature (4)							Compressor during operation							Actual compressor rotation speed (4)								
		Self-diagnosis (3 MSB)								Outside temperature (5)							Compressor during operation							Actual compressor rotation speed (5 MSB)								
		Fan-7-step request								Outside temperature (6)							Compressor during operation							Actual compressor rotation speed (7 MSB)								
		Fan-7-step request								Outside temperature (7 MSB)							Compressor during operation							Actual compressor rotation speed (7 MSB)								

(2) Indoor message

Character No.	0								1							2							3								
	Bit No.	7	6	5	4	3	2	1	0	1	2	3	4	5	6	7	0	1	2	3	4	5	6	7	0	1	2	3	4	5	6
	Operation mode (0 LSB)	1/0	1/0	1/0	1/0	1/0	1/0	1/0	0	Fan (0 LSB)	1/0	1/0	1/0	1/0	1/0	0	Fan (1)	1/0	1/0	1/0	1/0	1/0	1/0	0	15/20(A)	1/0	1/0	1/0	1/0	1/0	1/0
	Operation mode (1)	1/0	1/0	1/0	1/0	1/0	1/0	1/0	1	Fan (2 MSB)	1/0	1/0	1/0	1/0	1/0	1	Compressor command speed (1)	1/0	1/0	1/0	1/0	1/0	1/0	1	OVL up	1/0	1/0	1/0	1/0	1/0	1/0
	Operation mode (2 MSB)	1/0	1/0	1/0	1/0	1/0	1/0	1/0	2	2-way valve	1/0	1/0	1/0	1/0	1/0	2	Compressor command speed (2)	1/0	1/0	1/0	1/0	1/0	1/0	2		1/0	1/0	1/0	1/0	1/0	1/0
	Indoor in-operation bit	1/0	1/0	1/0	1/0	1/0	1/0	1/0	3	Fan (0 LSB)	1/0	1/0	1/0	1/0	1/0	3	Compressor command speed (3)	1/0	1/0	1/0	1/0	1/0	1/0	3	Compressor minimum rotation speed (0 LSB)	1/0	1/0	1/0	1/0	1/0	1/0
	Capacity code (0 LSB)	0	0	0	0	0	0	0	4	Reversing valve	1/0	1/0	1/0	1/0	1/0	4	Compressor command speed (4)	1/0	1/0	1/0	1/0	1/0	1/0	4	Compressor minimum rotation speed (1)	1/0	1/0	1/0	1/0	1/0	1/0
	Capacity code (1)	0	0	0	0	0	0	0	5	Capacity code (1)	0	0	0	0	0	5	Compressor command speed (5)	1/0	1/0	1/0	1/0	1/0	1/0	5	Compressor minimum rotation speed (2)	1/0	1/0	1/0	1/0	1/0	1/0
	Capacity code (2)	0	0	0	0	0	0	0	6	Capacity code (2)	0	0	0	0	0	6	Compressor command speed (6)	1/0	1/0	1/0	1/0	1/0	1/0	6	Compressor minimum rotation speed (3)	1/0	1/0	1/0	1/0	1/0	1/0
	Capacity code (3 MSB)	0	0	0	0	0	0	0	7	Capacity code (3 MSB)	0	0	0	0	0	7	Compressor command speed (7 MSB)	1/0	1/0	1/0	1/0	1/0	1/0	7	Compressor minimum rotation speed (4 MSB)	1/0	1/0	1/0	1/0	1/0	1/0

3. Power Module Circuit

- Fig. 3-1 shows the system power module and its peripheral circuit. The three transistors on the positive ⊕ side are called the upper arm, and the three transistors on the negative ⊖ side are called the lower arm.

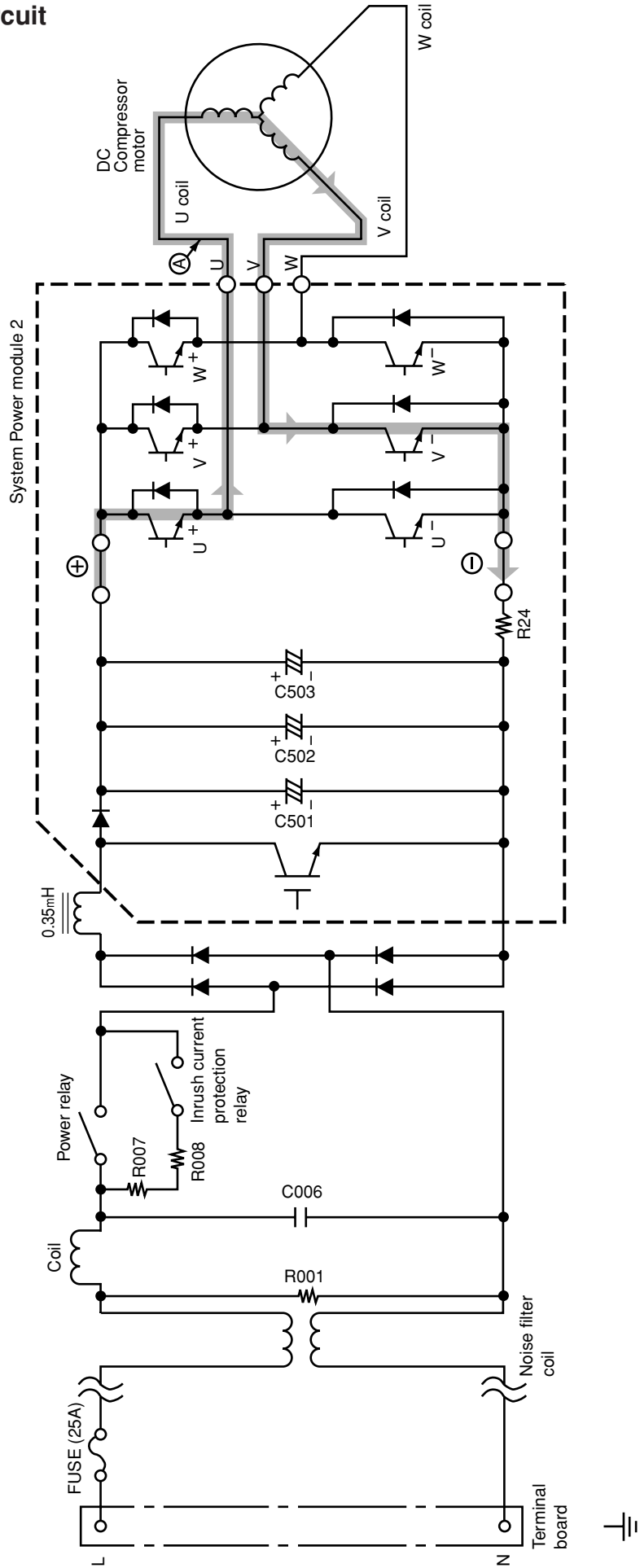

Fig. 3-1 Power module circuit (U⁺ is ON, V⁻ is ON)

- DC 260-360V is input to system power module and system power module switches power supply current according to rotation position of magnet rotor. The switching order is as shown in Fig. 3-2.

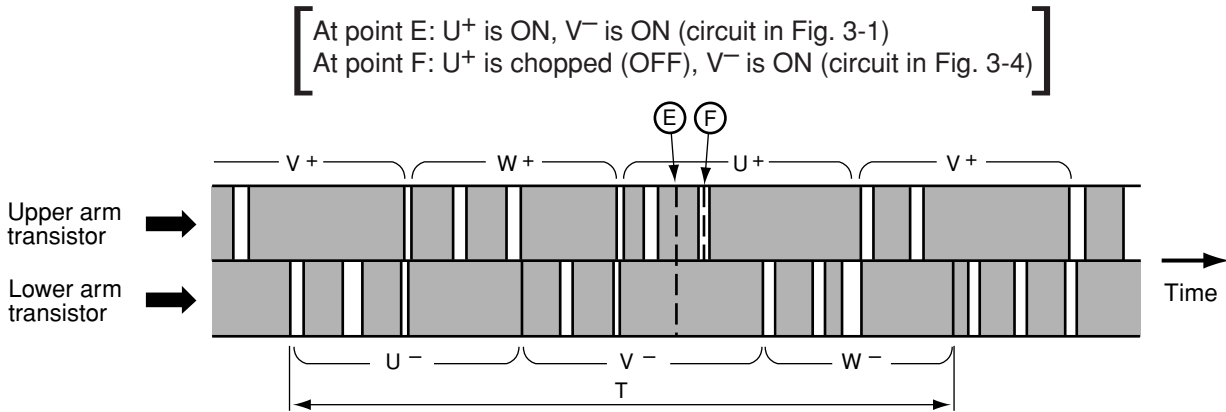

Fig. 3-2 Switching order of power module

- Upper arm transistor is controlled to ON/OFF by 3.3kHz chopper signal. Rotation speed of the compress is proportional to duty ratio (ON time/ ON time + OFF time) of this chopper signal.
- Time T in Fig. 3-2 shows the switching period, and relation with rotation speed (N) of the compressor is shown by formula below;

$$N = 60/2 \times 1/T$$

- Fig. 3-3 shows voltage waveform at each point shown in Figs. 3-1 and 3-4. First half of upper arm is chopper, second half is ON, and first half of lower arm is chopper, second half is ON.

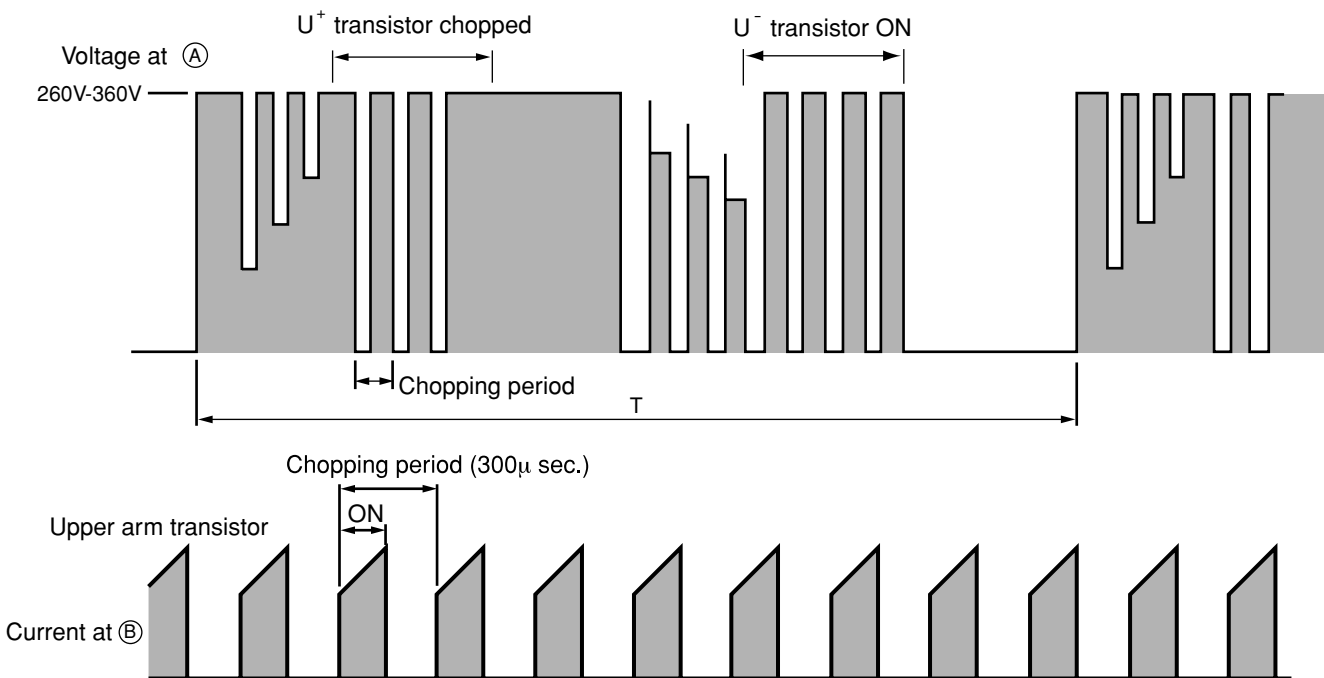

Fig. 3-3 Voltage waveform at each point

- When power is supplied U⁺ → U⁻, because of that U⁺ is chopped, current flows as shown below; (B)
 - (1) When U⁺ transistor is ON: U⁺ transistor → U coil → V coil → V⁻ transistor → DC current detection resistor → Point (B) (Fig. 3-1)
 - (2) When U⁺ transistor is OFF: (by inductance of motor coil) U coil → V coil → V⁻ transistor → Return diode → Point (A) (Fig. 3-4)

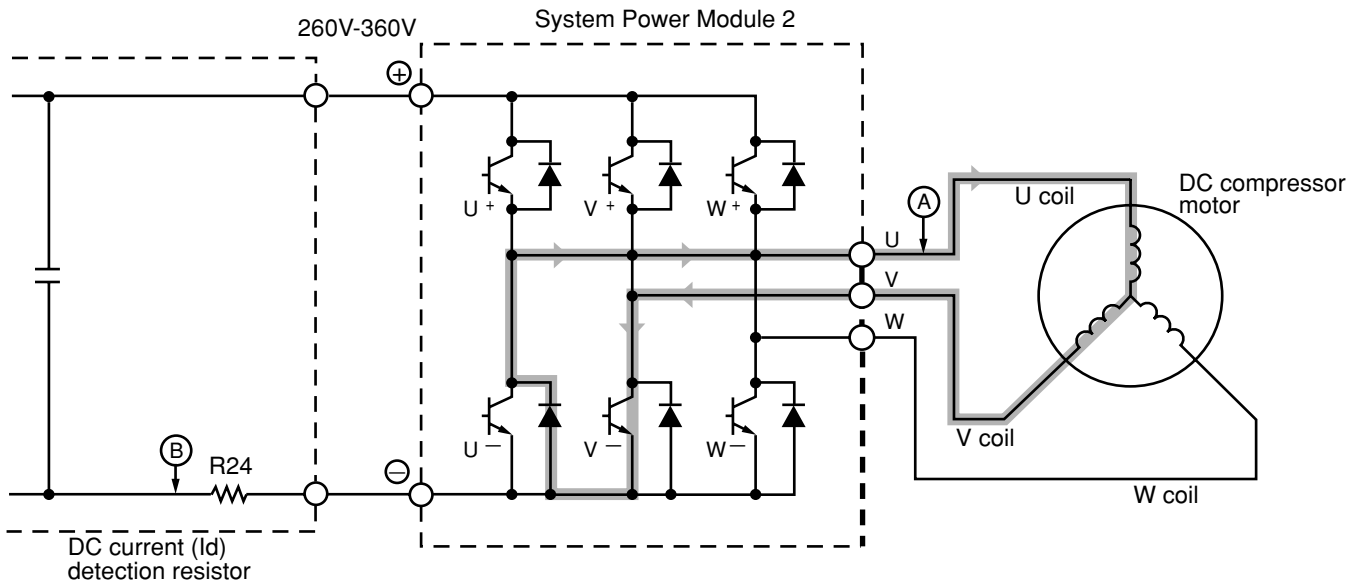

Fig. 3-4 Power module circuit (U⁺ is ON, V⁻ is ON)

- Since current flows at point ② only when U⁺ transistor is ON, the current waveform at point ② becomes intermittent waveform as shown in Fig. 3-3. Since current at point ② is approximately proportional to the input current of the air conditioner, input current is controlled by using DC current (I_d) detection resistor.

<Reference>

If power module is defective, self diagnosis lamps on the control P.W.B. may indicate as shown below:

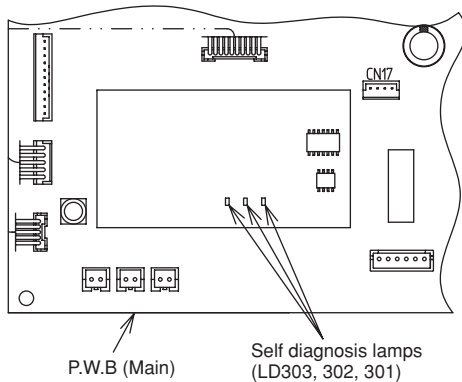

Fig. 3-5

Table 3-1

Self-diagnosis	Self-diagnosis lamp and mode	
I _p (peak current cut)	LD301	Blinks 2 times
Abnormal low speed rotation	LD301	Blinks 3 times
Switching incomplete	LD301	Blinks 4 times

- Simplified check of power module (Lighting mode when operated with compressor leads disconnected)
 - (1) Disconnect connector of 3-pole (WHT, YEL, RED) lead wire connecting to compressor located at the lower part of electric parts box.
 - (2) Set to compressor operation state (other than FAN mode) and press Start/stop switch of remote control.
 - (3) If normal operation continues for more than 1 minute (LD303 lights), power module is considered normal.
- * Refer to other item (troubleshooting on page 94) for independent checking of power module.

4. Power Circuit for P.W.B.

- Fig. 4-1 shows the power circuit for P.W.B. and waveform at each point.

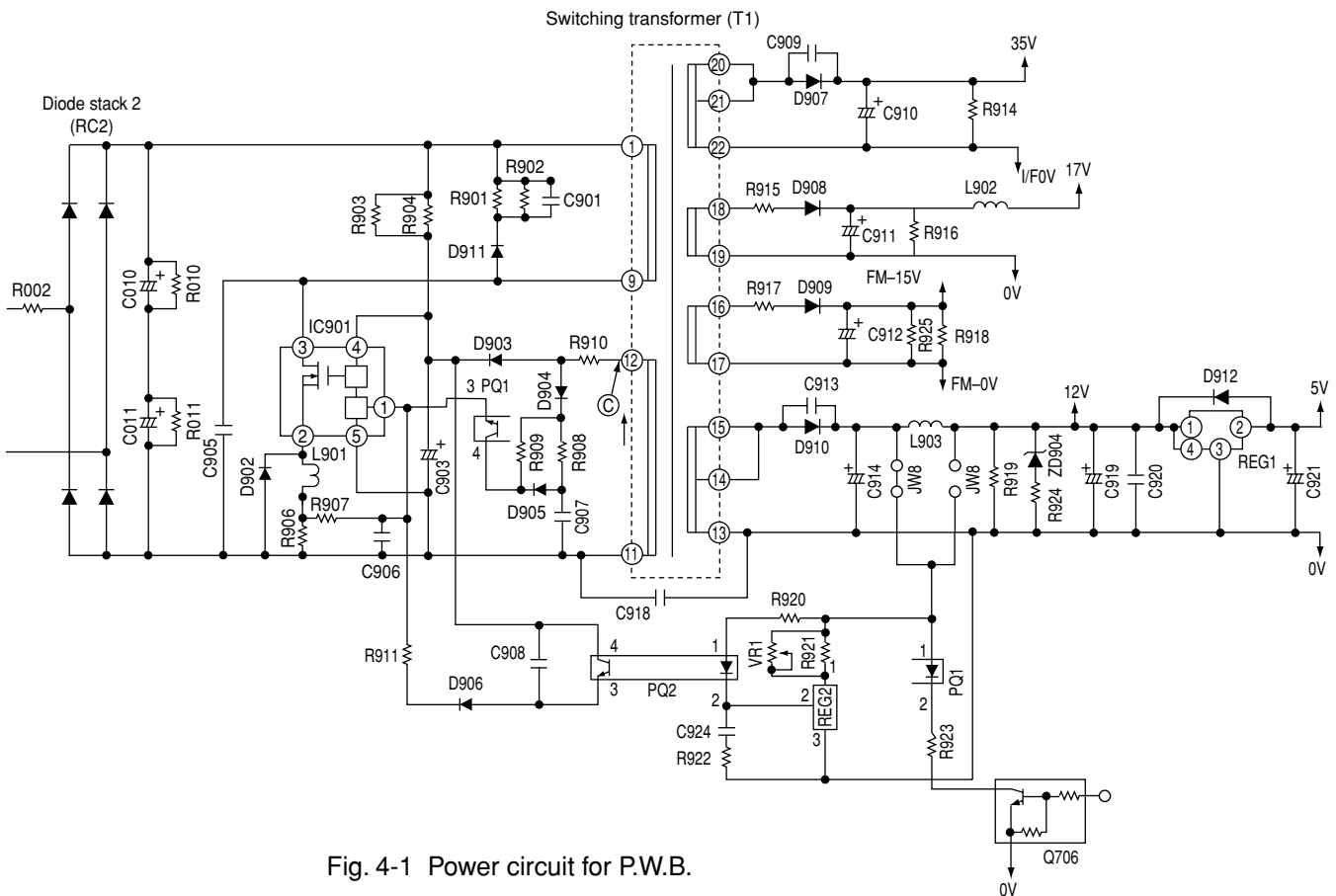

Fig. 4-1 Power circuit for P.W.B.

- In the power circuit for P.W.B., power supply for microcomputer, peripheral circuits, and system power module driver circuit and, as well as DC 35V, are produced by switching power circuit.
- Switching power circuit performs voltage conversion effectively by switching transistor IC901 to convert DC 330V voltage to high frequency of about 20kHz to 200kHz.
- Transistor IC901 operates as follows:

(1) Shifting from OFF to ON

- DC about 330V is applied from smoothing capacitors C010 ⊕ and C011 ⊖ in the control power circuit. With this power, current flows to pin (4) of IC901 via R903 and R904 and IC901 starts to turn ON. Since voltage in the direction of arrow generates at point (C) at the same time, current passing through R910 and D903 is positive-fed back to IC901.

(2) During ON

- The drain current at IC901 increases linearly. During this period, the gate voltage and current become constant because of the saturation characteristics of the transformer.

(3) Shifting from ON to OFF

- This circuit applies a negative feedback signal from the 12V output. When the voltage across C919 reaches the specified value, REG2 turns on and current flows to PQ2 ①-②. This turns the secondary circuits on, sets IC901 pin ① to "Hi", and turns IC901 off.

(4) During OFF

- While IC901 is on, the following energy charges the primary windings of the transformer:

Energy= $LI^2/2$. Here, L : Primary inductance

I : Current when IC1 is off

This energy discharges to the secondary windings during power off. That is, C910, C911, C912, C914 is charged according to the turn ratio of each winding.

- At the start, an overcurrent flows to IC901 because of the charged current at C910, C911, C912, C914.
- The drain current at IC901 generates a voltage across R906. If it exceeds the IC901 base voltage, it sets the IC901 gate voltage to "HI".
- R906 limits the gate voltage to prevent excessive collector current from flowing to IC901.

<Reference>

If the power circuit for P.W.B. seems to be faulty:

- (1) Make sure that 5V and 12V on the control P.W.B., upper arm U, V and W, and the lower arm power voltage are the specified values.

- (2) When only the 5V output is low:

REG 1 (regulator) faulty, 5V-0V shorted, output is too high, or REG 1 is abnormal.

- (3) When 12V and 5V are abnormal:

The following defects can be considered:

① Fan, operation, power, rush prevention relay (shorting in relay, etc.)

② Microcomputer is abnormal.

③ REG 1 (regulator is abnormal), etc.

Shorting on primary circuits.

When shorting occurs in the secondary circuits, there is no abnormality in the primary circuits because of overcurrent protection.

The voltage rises when an opening occurs in the primary circuits, or the feedback system is abnormal.

- (4) When 15V and 17V are abnormal:

D908, D909 or drive circuit is abnormal.

- (5) When all voltage are abnormal:

IC901, R906, etc. are possibly abnormal.

- * If IC901 is abnormal, be aware that other components, such as the power module, REG (regulator), etc. are possibly defective.

[When the switching power supply seems to be abnormal, the voltage between IC901 pin ④ (to be measured at the leads of R904 and R903) and IC901 pin ⑤ (to be measured at R906 lead) may be between 11 and 16V. This is because the protection circuit of IC901 is operating.]

5. Reversing valve control circuit

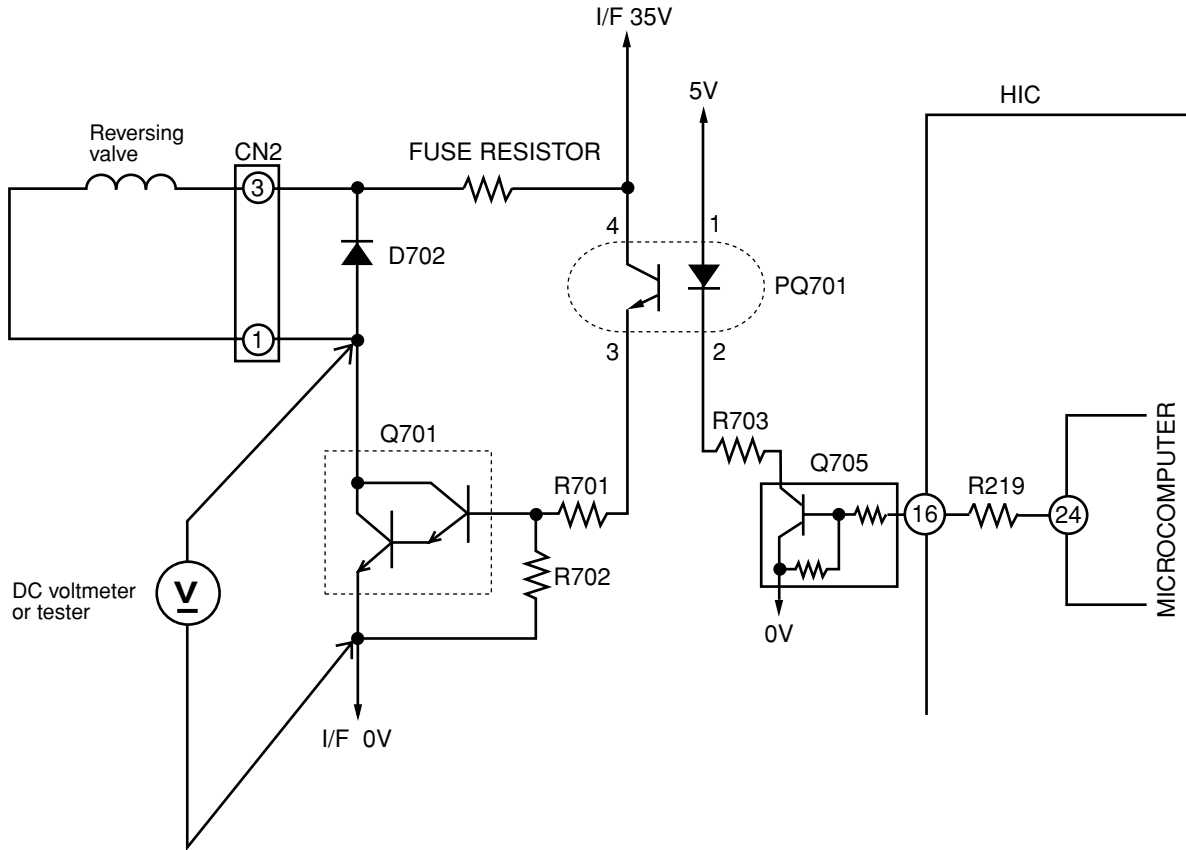

Fig. 5 - 1

- Reversing valve control circuit can switch reversing valve ON/OFF according to instruction from indoor microcomputer depending on the operation condition shows in Table 5-1. Voltage at each point in each operation condition is approximately as shown below when measured by tester. (When collector voltage of Q701 is measured)

Table 5-1

Operation condition		Collector voltage of Q701
Cooling	General operation of Cooling	About 35V
Heating	In normal heating operation	About 0.8V
	MAX. rotation speed instructed by indoor microcomputer after defrost is completed	About 0.8V
	Defrosting	About 35V
Dehumidifying	Sensor dry	About 35V

6. Rotor magnetic pole position detection circuit

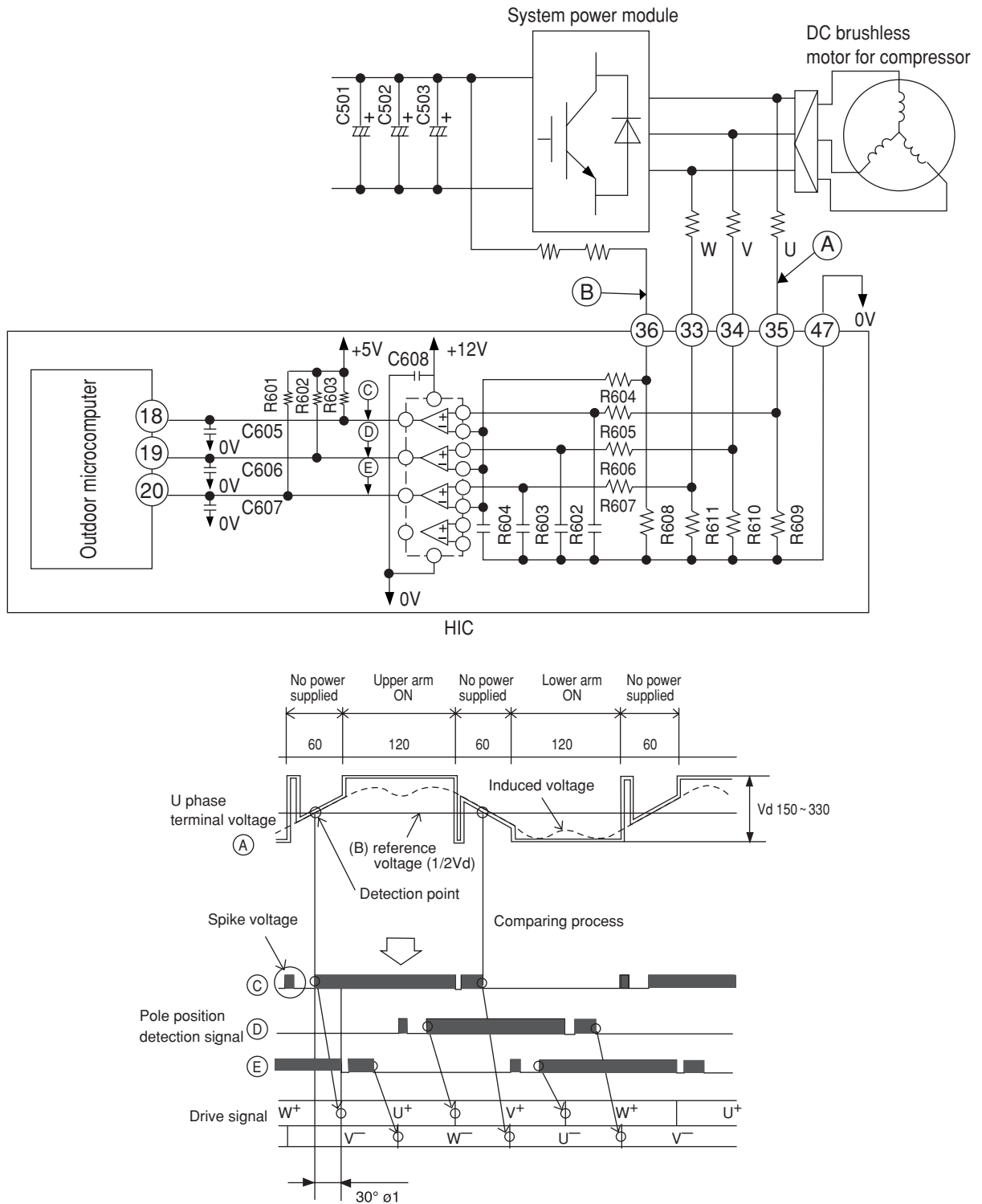

Fig. 6-1 Rotor magnetic pole position detection circuit and voltage waveform at each point

- To detect U phase, voltage at point (C) is produced by driving motor induced voltage signal (voltage at point (A)) and 1/2 voltage of Vd (voltage at point (B)), and comparing with comparator.
- For V phase and W phase, voltage at point (D) and voltage at point (E) are produced in the same way as above. Voltage at point (C) is taken into indoor unit microcomputer, switching timing to U⁺ transistor from W⁺ transistor is produced by delaying 30° from rise waveform, ignoring spike voltage. In addition, switching timing to U-transistor from W-transistor is produced by delaying 30° from fall waveform.
- For V phase and W phase, in the same way as above, drive signals are produced from voltages at point (D) and point (E). Phases are shifted by 120° and 240°, respectively, comparing with U phase.

7. Drive Circuit

Fig. 7-1 shows the drive circuit. The circuits for U phase, V phase and W phase have the same Configuration.

- In low speed rotation mode (PWM range), as shown in Fig. 7-2, 0-5V chopper signal is output from microcomputer for each phase. Signal output from microcomputer is output to IC1 and is inverted by active Lo to become 0-15V chopper signal; it is then drive the transistor of each phase.
- In high speed rotation mode (PWM range), as shown in Fig. 7-3, 0-5V drive signal is output from microcomputer for each phase (with no chopper because of full duty). Signal output from microcomputer is input to IC1 and is inverted by active Lo to become 0-15V drive signal; it is then drive the transistor of each phase.

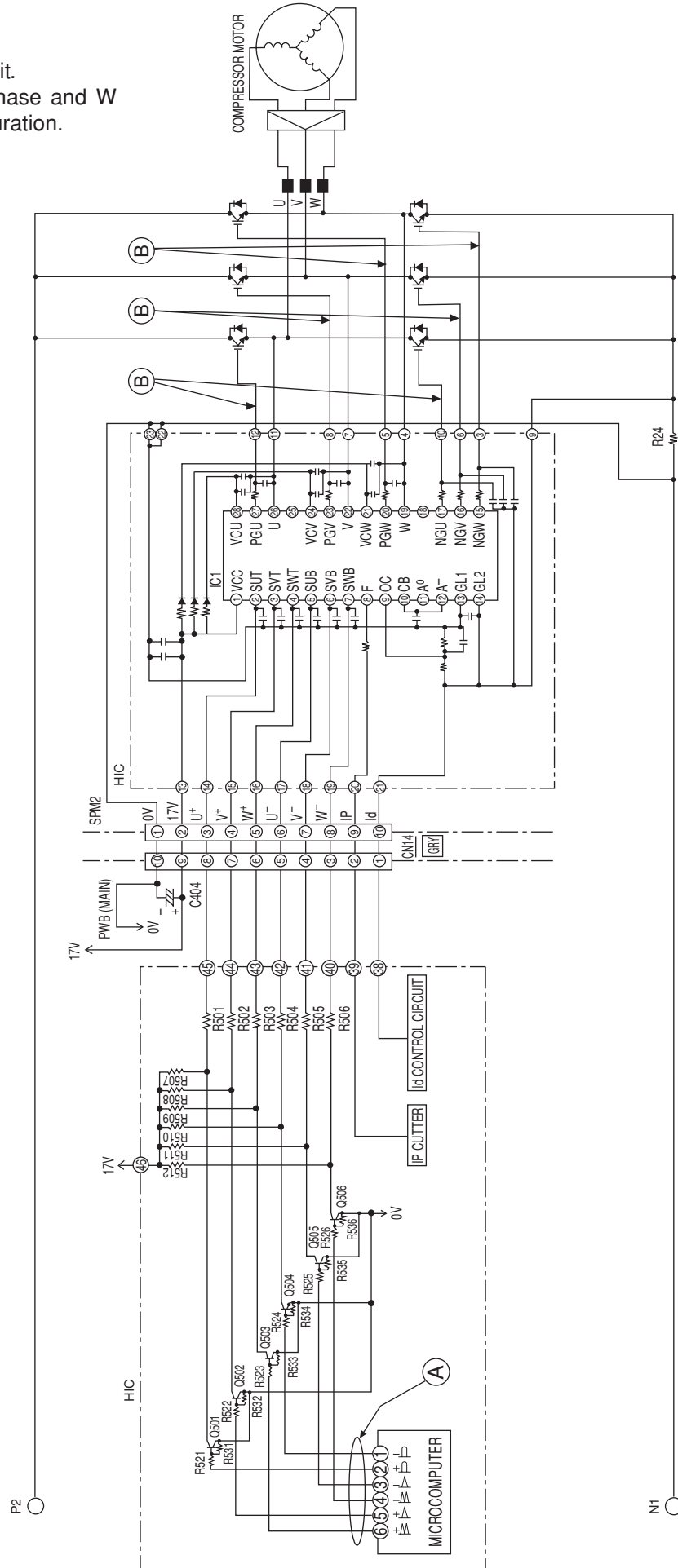

Fig.. 7-1

[Low speed rotation mode]

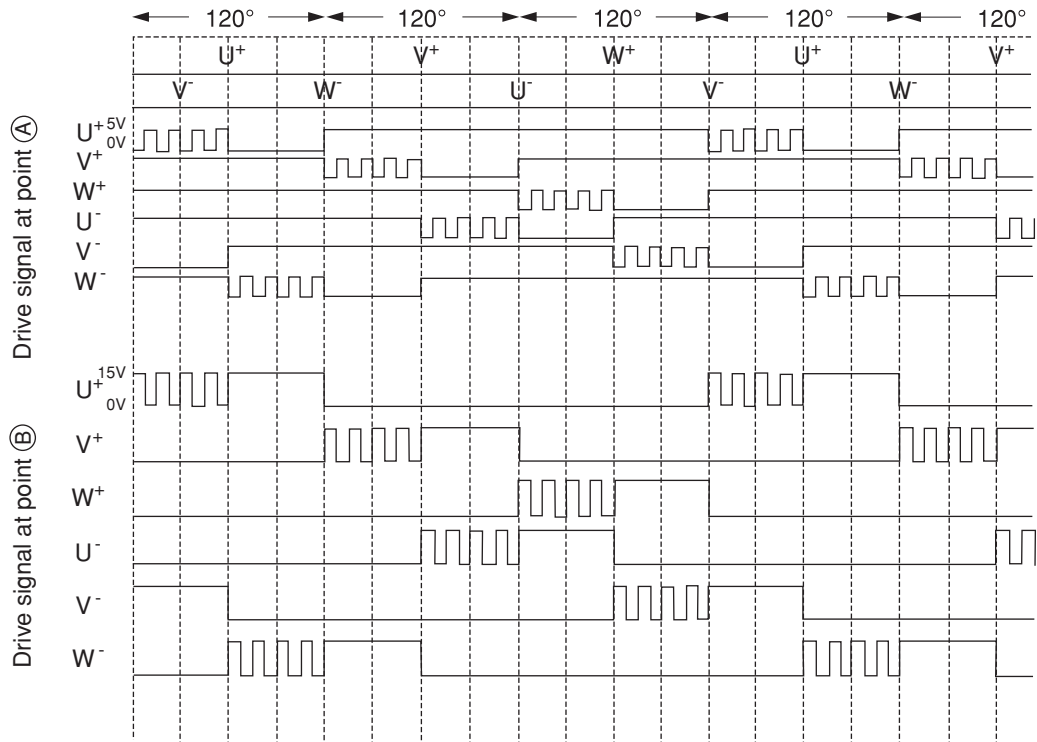

Fig. 7-2

[High speed rotation mode]

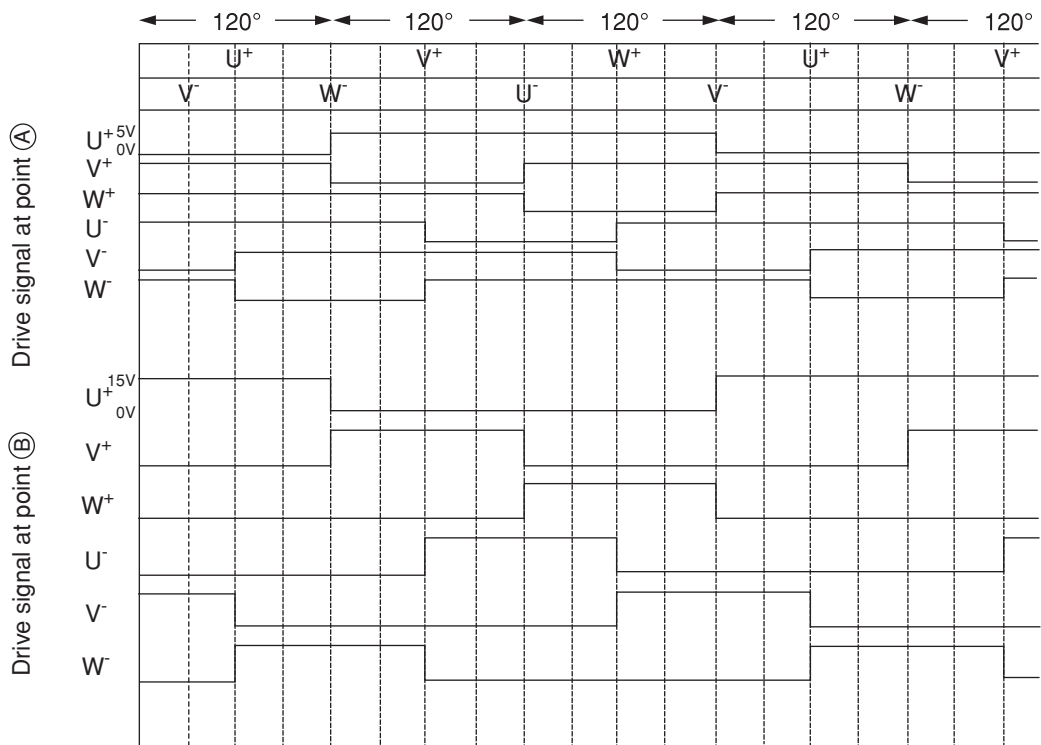

Fig. 7-3

8. HIC and Peripheral Circuits

- Fig. 8-1 shows the micro computer and its peripheral circuits, Table 8-1, the basic operations of each circuit block, and Fig. 8-2, the system configuration.

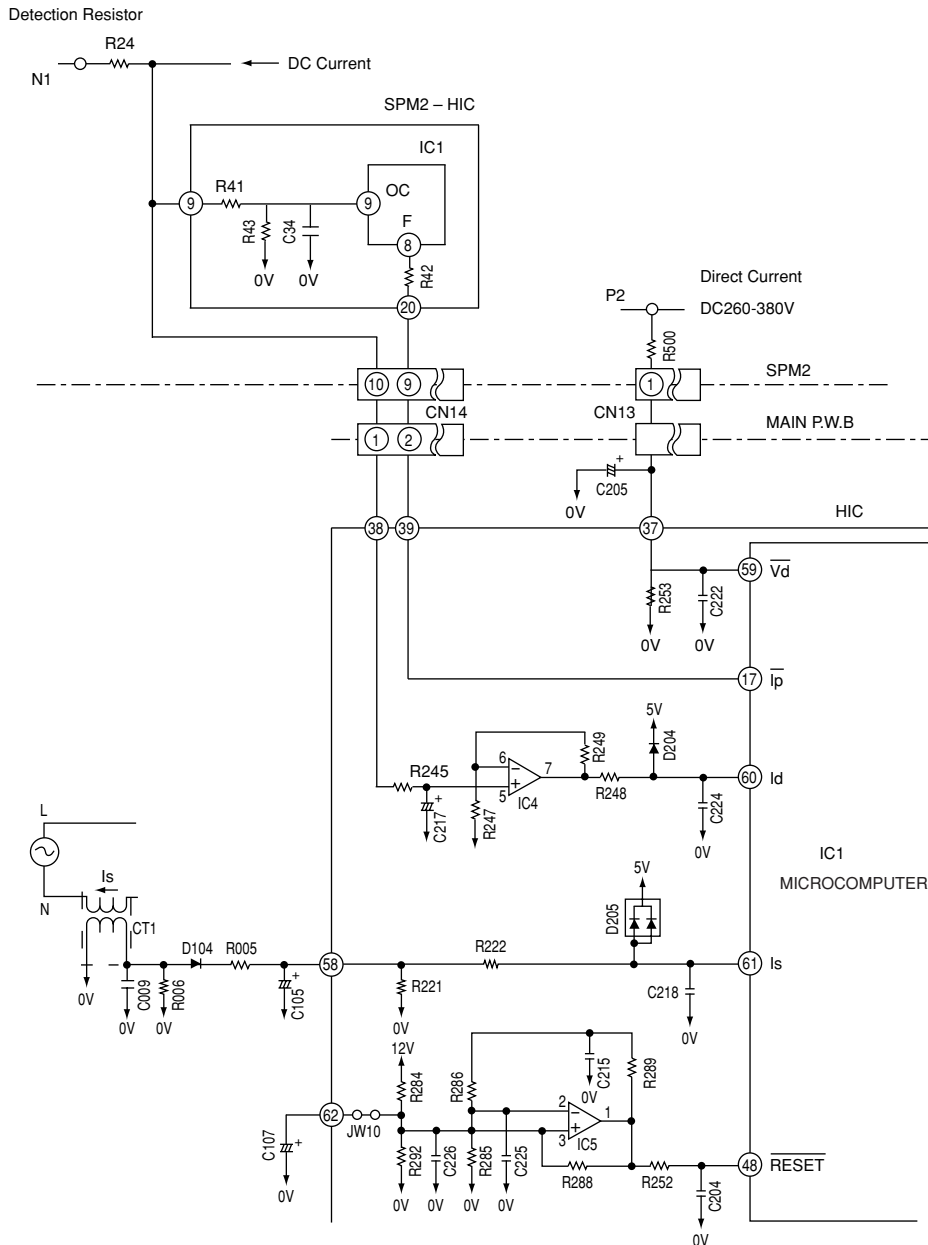

Fig. 8-1 Microcomputer and Peripheral Circuits

Table 8-1

Circuit block	Basic operation
Peak current cutoff circuit	Detects DC current flowing power module and during overcurrent (instantaneous value) flows, stops upper/lower arm drive circuits and also produces Ip signal by which drive signal output is stopped.
Set value circuit	Compares voltage detected, amplified and input to HIC with set voltage value in microcomputer, and controls overload when set value exceeds input voltage.
Voltage amplifier circuit	Voltage-amplifies DC current level detected by the detection resistor and inputs this to microcomputer. Internal or external overload is judged in microcomputer.
Reset circuit	Produces reset voltage.
Trip signal synthesis circuit	Modulates chopper signal to drive signal and stops according to presence/absence of Ip signal or reset signal.

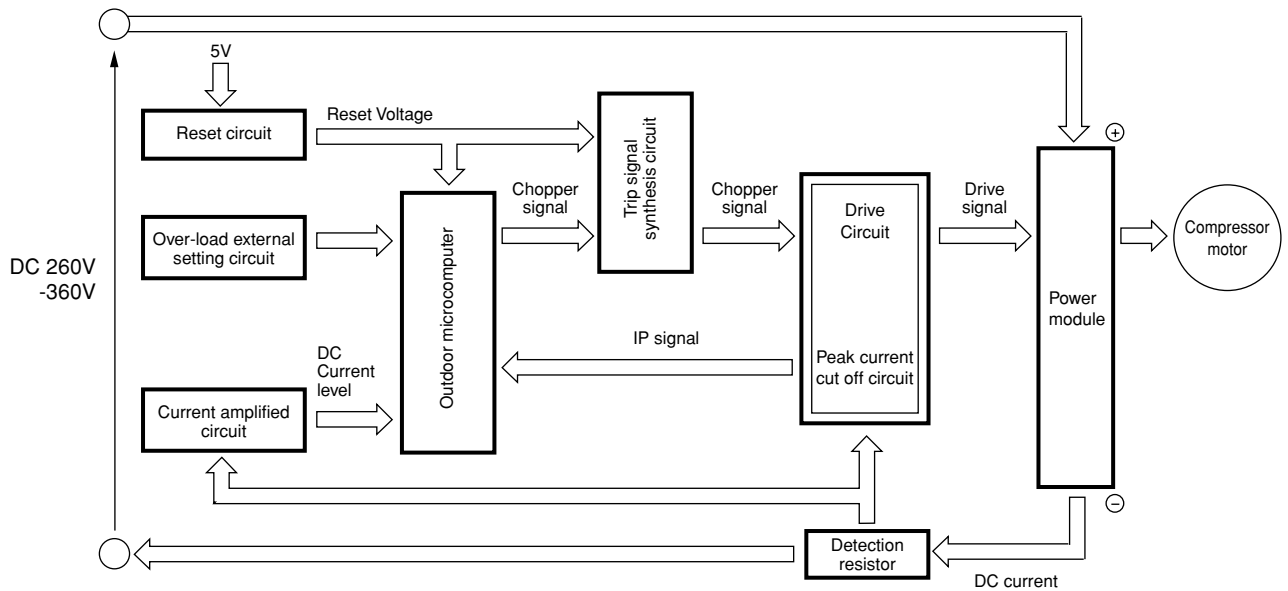

Fig. 8-2

- The following describes the operations of each circuit in detail.

(1) Peak current cut off circuit

Fig.8-3 Peak Current Cut off Circuit and Waveforms at Each Section.

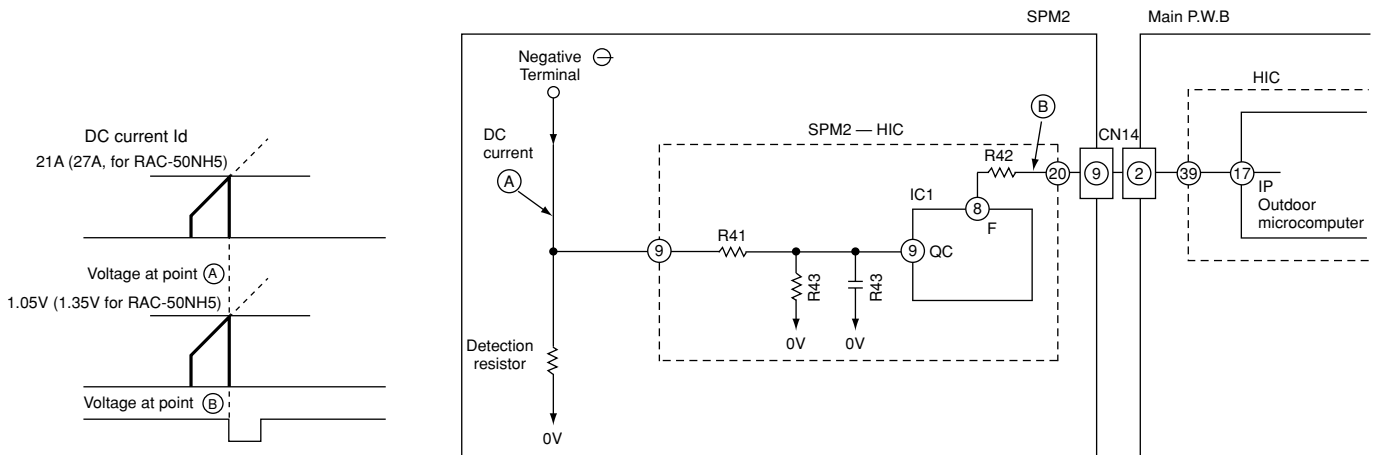

Fig.8-3

- The Ip cut off circuit detects an instantaneous excessive current and stops inverter to protect parts such as SPM2, etc.
- As shown in diagram, if current exceeding 21A (27A for RAC-50NH5) flows, voltage at point (A) recognized by detecting resistor is input to pin ⑩ of SPM2 – HIC, and voltage divided by R41 and R43 is input to pin ⑨ of IC1. Since threshold of IC1 is exceeded in this case, Lo signal is input from pin ⑧ (Voltage at point (B)). When Lo signal is input to pin ⑰ of microcomputer, microcomputer stops drive output.
- When drive output from microcomputer is stopped, all drive output goes Hi, and microcomputer is initialized to enter drive signal standby mode. 3 minutes later, microcomputer outputs drive signal again, to start operation.

(2) Overload control circuit (OVL control circuit)

- Overload control is to decrease the speed of the compressor and reduce the load when the load on the air conditioner increases to an overload state, in order to protect the compressor, electronic components and power breaker.
- Overloads are judged by comparing the DC current level and set value.
- Fig. 8-4 shows the overload control system configuration and Fig. 8-5 is a characteristic diagram of overload judgement values. There are two judgement methods-external judgement which compares the externally set value with the DC current value regardless of the rotation speed and internal judgement which compares the set value that varies according to the rotation speed programmed in the microcomputer software with the DC current value.

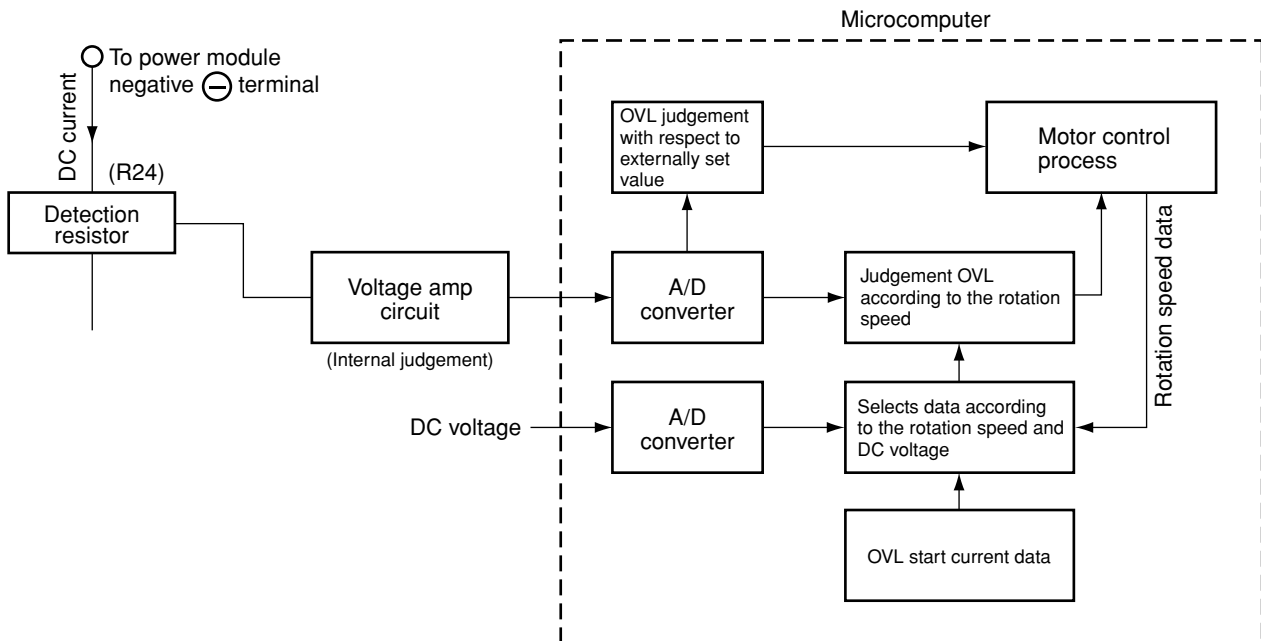

Fig. 8-4 Overload Control System Configuration

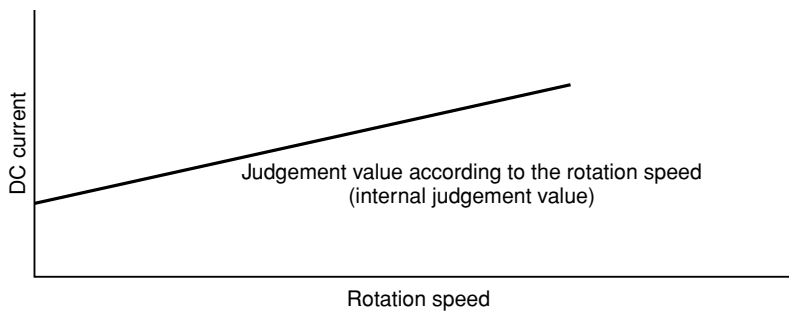

Fig. 8-5

①. Overload external judgement circuit

- Fig. 8-1. The filter consisting of R245 and C217 removes high harmonic components from the voltage generated by the current flowing to Detection resistor; R245 and C217 average the voltage. This voltage is then input to IC4 pin ⑤ is then amplified and supplied to microcomputer pin ⑩. The microcomputer compares this input with the internally set value, and if the input exceeds the set value, it enters overload control status.
- Fig. 8-7 shows the rotation speed control. When the voltage at pin ⑩ of the microcomputer exceeds the set value, the microcomputer decreases the rotation speed of the compressor and reduces the load regardless of the rotation speed commanded by the indoor microcomputer.

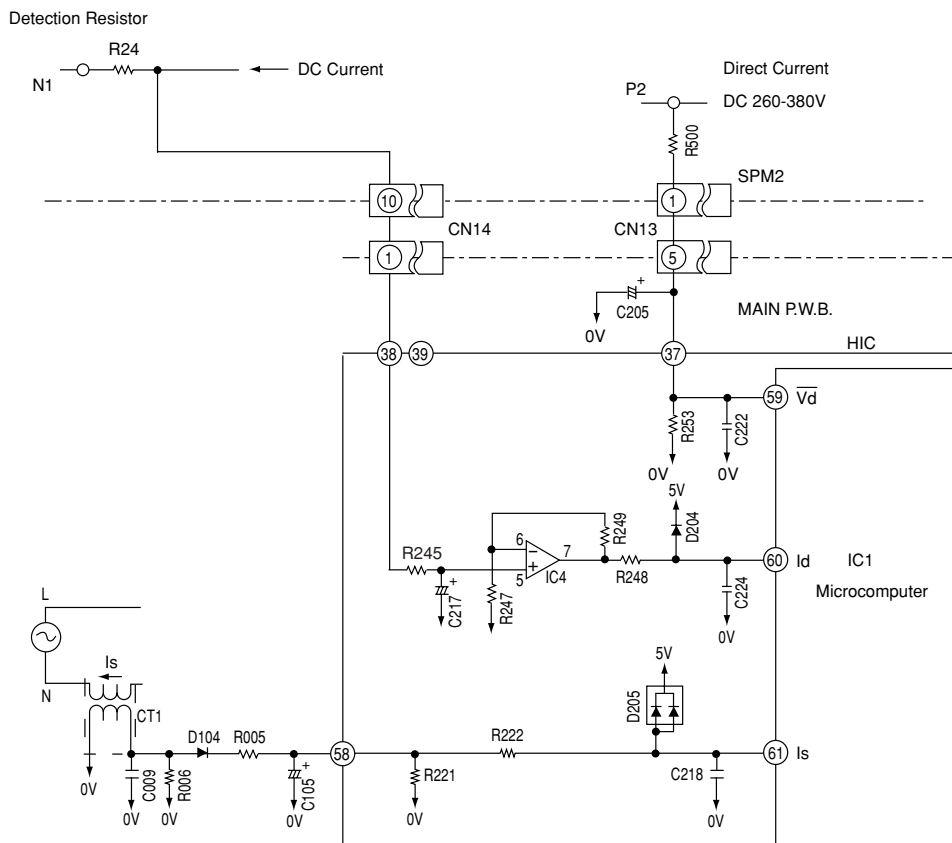

Fig. 8-6

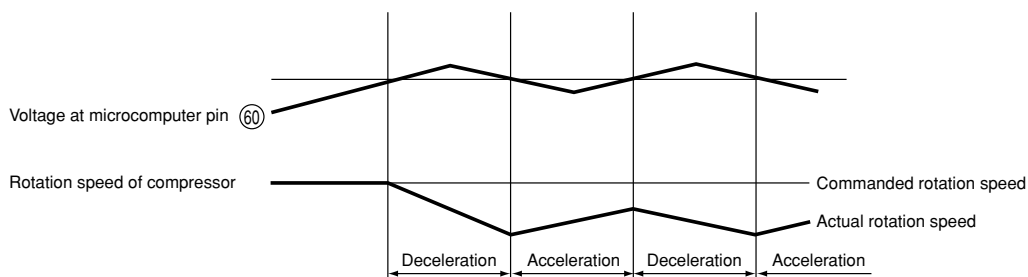

Fig. 8-7

②. Voltage amp. circuit

- The voltage amp. circuit amplifies the DC current level detected by the detection resistor after being converted to a voltage and supplies it to the microcomputer. Receiving this, the microcomputer converts it to a digital signal and compares it with the internal data to judge whether or not overload control is required.

< During overload control >

- The filter consisting of R245 and C217 removes high harmonic components from the voltage generated from the DC current flowing to the detection resistor, and supplies it to IC4 pin ⑤ IC4 forms a non-inverting voltage amp. circuit together with the peripheral elements.
- The microcomputer stores the set values which vary according to the rotation speed. When the DC current level exceeds the set value, the microcomputer enters the overload control state.
- The set Value is determined by the amplification of the voltage amp. circuit.

- Amplification : high → DC current : low
- Amplification : low → DC current: high

- R500, R253, detect the DC voltage at the power circuit. The microcomputer receives a DC voltage (260-380V) via HIC (37) and applies correction to the overload set value so the DC current is low (high) when the DC voltage is high (low).

(Since the load level is indicated by the DC voltage multiplied by DC current, R247, R248, R249 are provided to perform the same overload judgement even when the voltage varies.)

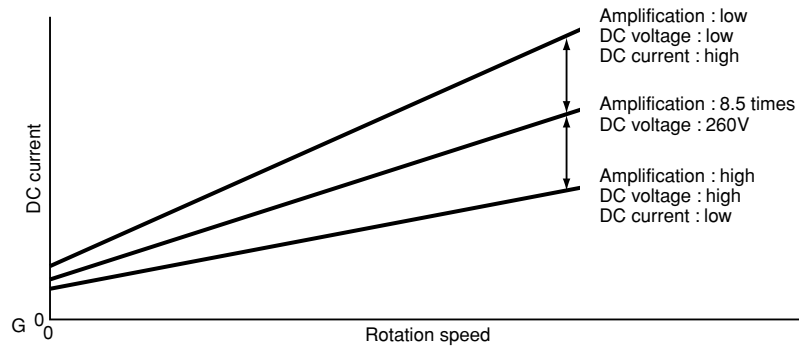

Fig. 8-8

< During start current control >

- It is required to maintain the start current (DC current) constant to smooth the start of the DC motor for the compressor.
- RAC-25NH5, RAC-35NH5, RAC-50NH5 uses software to control the start current.
- The start current varies when the supply voltage varies. This control method copes with variations in the voltages as follows.

(1) Turns on the power module's U⁺ and V⁻ transistors so the current flows to the motor windings as shown in Fig8-9.

(2) Varies the turn-ON time of the W⁺ transistor according to the DC voltage level and the start is controlled so the start current is approx. 10A as shown in Fig. 8-10.

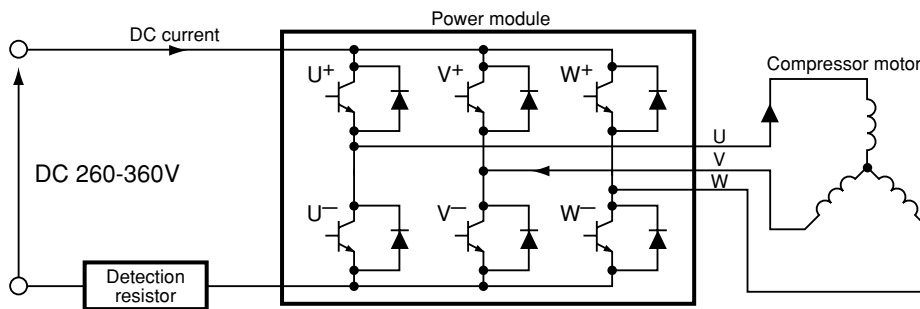

Fig. 8-9

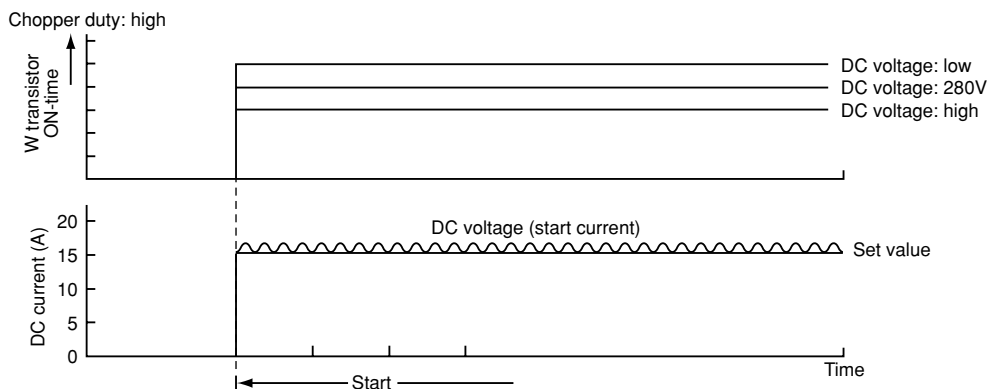

Fig. 8-10

9. Temperature Detection Circuit

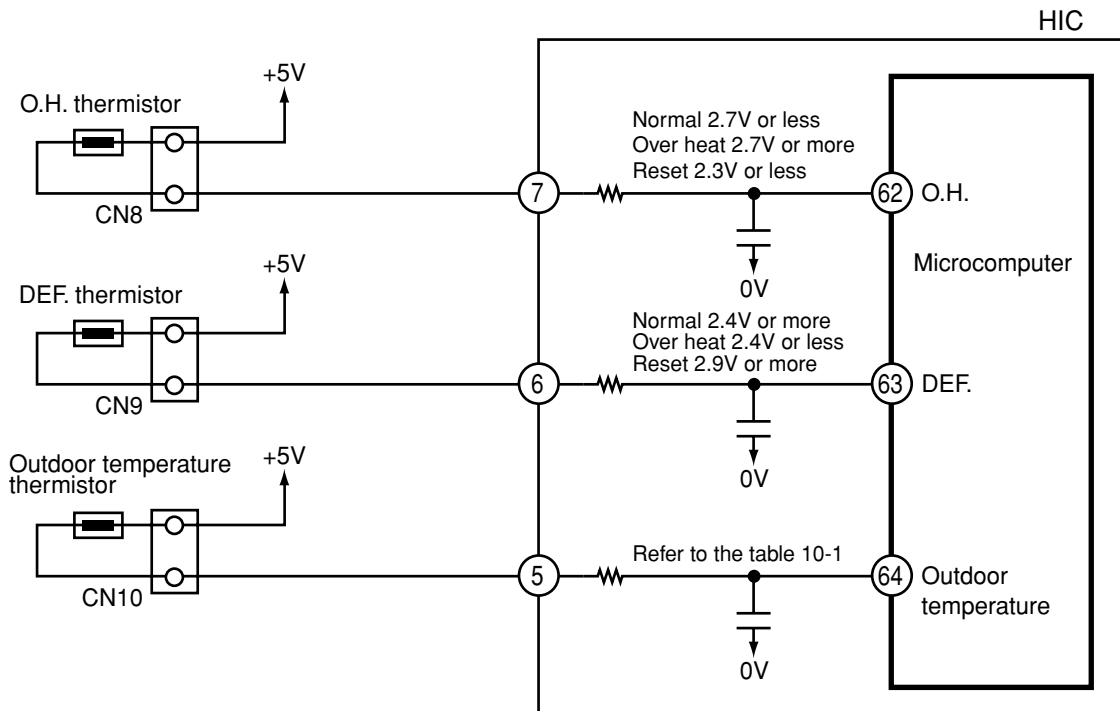

Fig. 9-1

- The Over heat thermistor circuit detects the temperature at the surface of the compressor head, the Defrost. thermistor circuit detects the defrosting operation temperature.
- A thermistor is a negative resistor element which has the characteristics that the higher (lower) the temperature, the lower (higher) the resistance.
- When the compressor is heated, the resistance of the Over heat thermistor becomes low and voltage at pin ⑥② of microcomputer is increased.
- Microcomputer compares the voltage present at pin ⑥② with the internal set value, if it is exceeded the set value microcomputer judges that the compressor is overheated and stops operation.
- When frost forms on the outdoor heat exchanger, the temperature at the exchanger drops abruptly. Therefore the resistance of the Defrost. thermistor becomes high and the voltage at pin ⑥③ of microcomputer drops. If this voltage becomes lower than the set value stored inside, the microcomputer starts defrosting control.
- During defrosting operation the microcomputer transfers the defrosting condition command to the indoor microcomputer via the circuit interface.
- The microcomputer always reads the outdoor temperature via a thermistor (microcomputer pin ⑥④), and transfers it to the indoor unit, thus controlling the compressor rotation speed according to the value set at the EEPROM in the indoor unit, and switching the operation status (outdoor fan on/off, etc.) in the dry mode.

The following shows the typical values of outdoor temperature in relation to the voltage:

Table 9-1

Outdoor temperature (°C)	-10	0	10	20	30	40
Microcomputer pin ⑤ voltage (V)	1.19	1.69	2.23	2.75	3.22	3.62

<Reference>

When the thermistor is open, in open status, or is disconnected, microcomputer pins ⑥②–⑥④ are approx. 0V; when the thermistor is shorted, they are approx. 5 V, and LD301 blinks seven times.

However, an error is detected only when the OH thermistor is shorted; in such a case, the blinking mode is entered 12 minutes after the compressor starts operation.

10. Reset Circuit

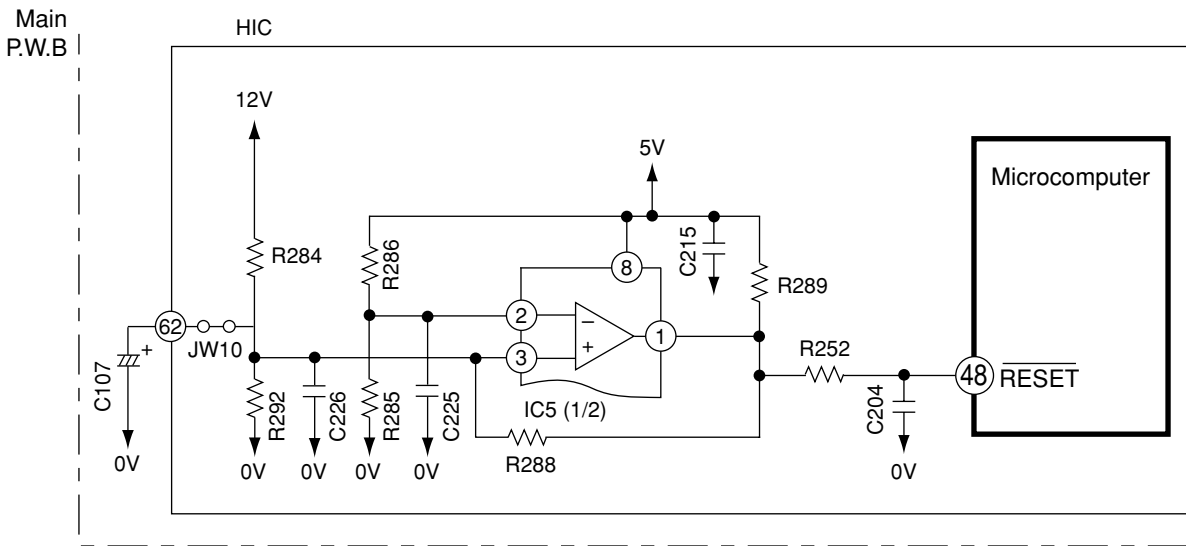

Fig. 10-1

- The reset circuit initializes the microcomputer program when Power is "ON" or "OFF".
- Low voltage at pin (48) resets the microcomputer, and HI activates the microcomputer.
- Fig. 10-1 shows the reset circuit and Fig. 10-2 shows waveform at each point when power is turned on and off.
- When power is turned on, 12V line and 5V line voltages rise and 12V line voltage reaches 10.9V and reset voltage input to pin (48) of microcomputer is set to Hi.
- Reset voltage will be hold "Hi" until the 12V line voltage drops to 9.90V even though the power shuts down.

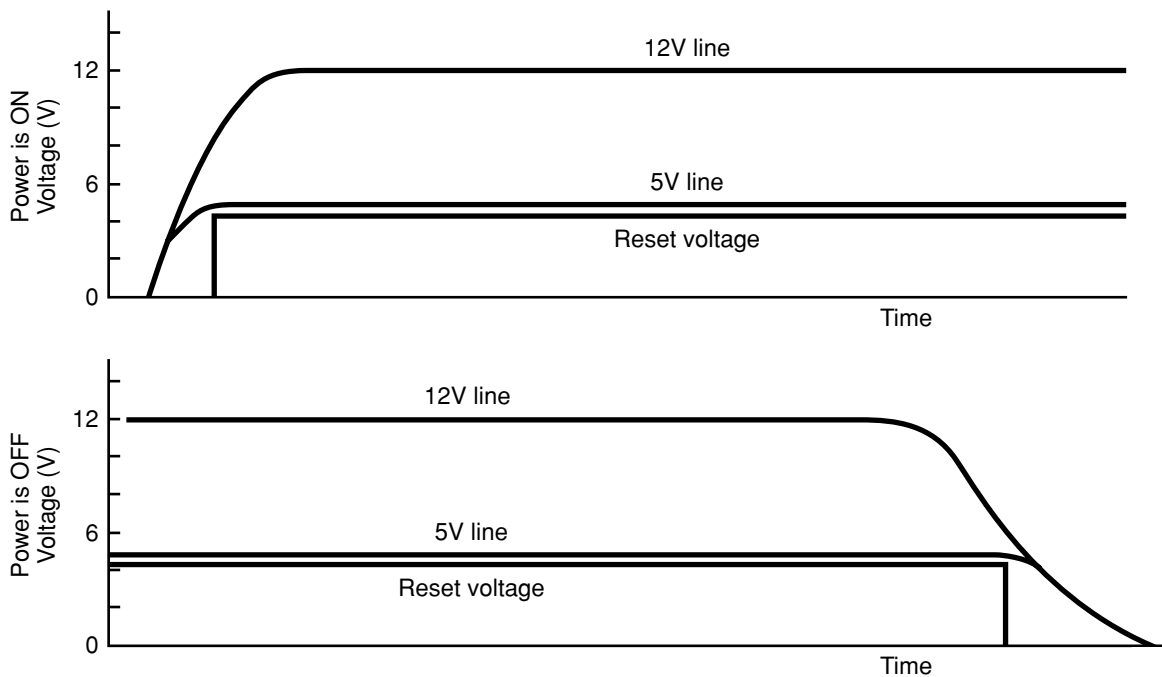

Fig. 10-2

11. Outdoor DC Fan Motor control circuit.

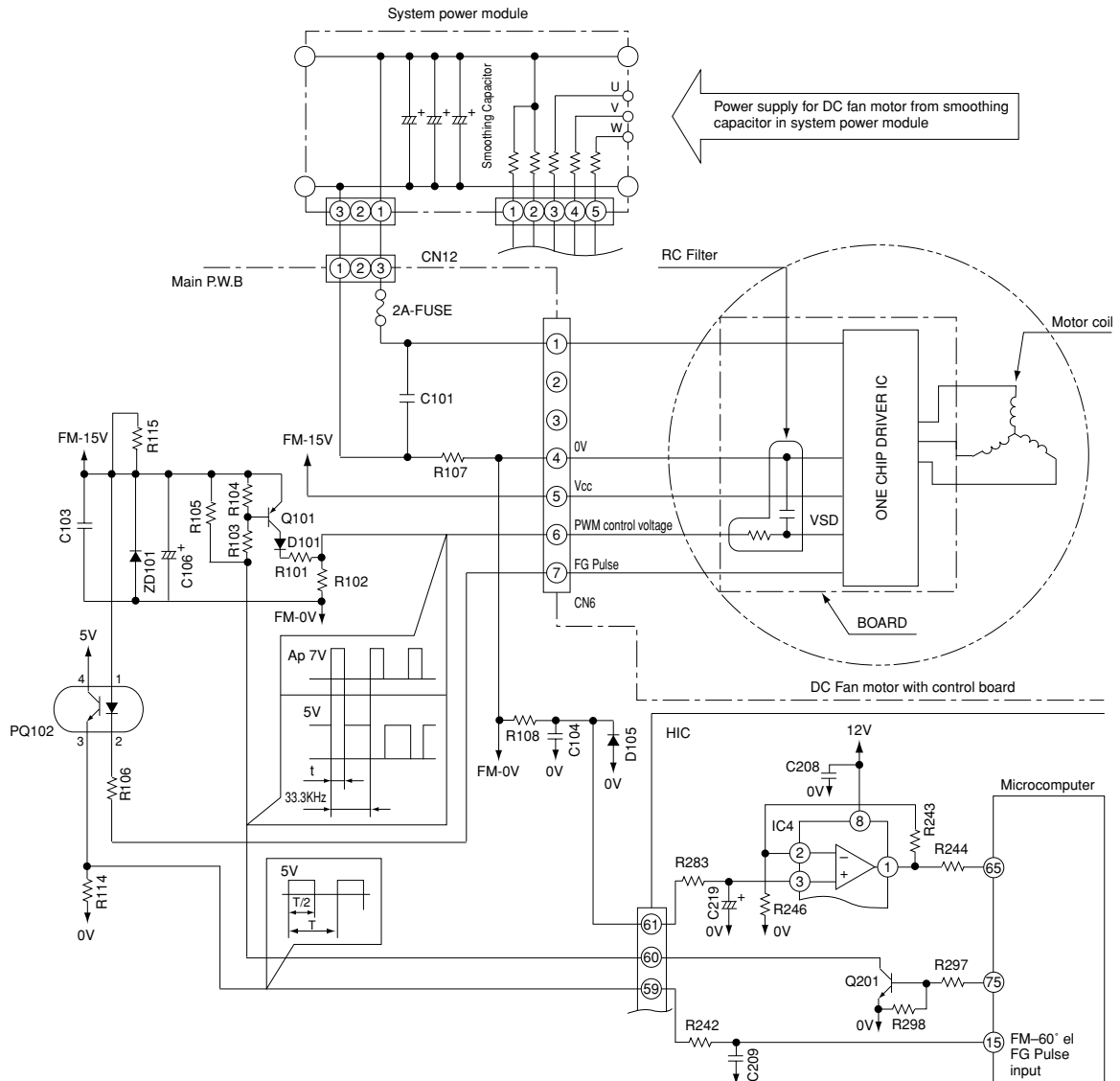

Fig. 11-1

- This model uses DC Fan Motor which has a controller circuit in the Motor.
- This DC Fan Motor will rotate by control voltage apply to Vsp input. (Voltage range: 1.7 to 7V DC)
Vsp high : Faster ; Vsp low : slower ; Vsp lower than 1.7V : stop
- Motor will output FG pulse by following this motor revolution.
- Outdoor Microprocessor will output PWM control signal from FMCHOP terminal by following the instruction from indoor Microprocessor.
- This PWM control signal will convert to Vsp voltage by smoothing circuit (Q101 & RC filter)
- Fan motor will start to rotate when Vsp was proceeding over than 1.7V, and generate FG pulse by rotation speed.
- FG pulse will feed back to Outdoor Microprocessor through PQ102.
- PQ102 is the isolator between Microprocessor circuit and DC Fan Motor circuit, which has to match the Fan Motor revolution with instructed revolution. Such as...
FG feedback: Faster – Instruction: Slower ... Decrease pulse width
FG feedback: Slower – Instruction: Faster ... Increase pulse width
- FG pulse is also used for Fan Motor failure detection
- Microprocessor will monitor FG pulse 30 seconds after start the fan motor. If there is no signal detected, it will consider that the Fan Motor was malfunction and stop the operation. In this case, LD302 on control PWB will blink 12 times. (Fan Motor lock detected)
- R107 and IC4 are used for Fan Motor over current

< Reference >

- When operation stop with LD301 blinks 12 times, it may be caused by faulty DC fan motor.
- In this case, please check CN6 and CN12 connection first. It makes Fan Motor Lock also if those connectors are in misconnection.
- DC Fan Motor has broken when 2A Fuse was burned. Please replace both DC Fan Motor and 2A Fuse together.
- It will makes "Fan Lock Stop"when something has disturb the Fan rotation by inserting materials into propeller fan or ice has growing inside of outdoor unit by snowing.
- It may make "Fan Lock Stop" by strong wind (ex. 17m/sec or above) against the Fan rotation. In this case, unit will be restart again after a while.
- In case of "Fan Lock Stop" even though the DC Fan Motor is rotating correctly, the possible casue is Fan Motor problem or PQ102 on board or control board problem. Stop after the Fan motor runs 2 minutes, Fan Motor may be broken.

< Caution >

- Please take care for the electrical shock by high voltage of DC Fan Motor power source which is common with compressor when you are servicing this unit.
- You can not confirm the coil and wiring of Motor due to the built in control circuit in Fan Motor.

12. Power Factor Control Circuit

Power factor is controlled to almost 100%. (Effective use of power)

With IC in ACT module, control is performed so that input current waveform will be similar to waveform of input voltage

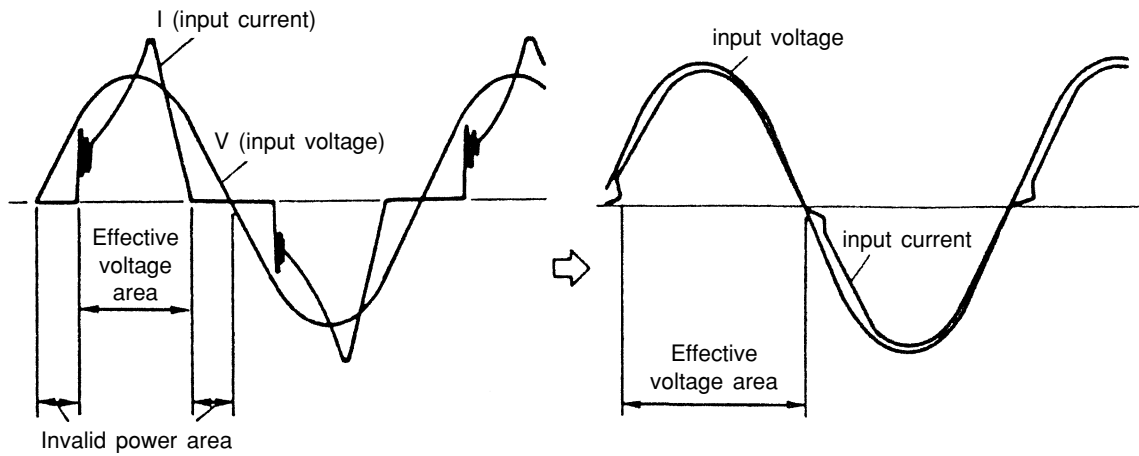

(Even if voltage is applied, current does not flow)

* Assuming the same current capacity (20A), power can be used about 10% effective, comparing with current use (power factor of 90%), and maximum capacity is thereby improved.

SERVICE CALL Q & A

Model RAD-18NH7A, RAD-25NH7A, RAD-35NH7A, RAD-50NH7A

COOLING MODE

Q1) The compressor has stopped suddenly during cooling operation.



A1) Check if the indoor heat exchanger is frosted. Wait for 3-4 minutes until it is defrosted.

If the air conditioner operates in cooling mode when it is cold, the evaporator may get frosted.

DEHUMIDIFYING MODE

Q2) Sound of running water is heard from indoor unit during dehumidifying.



A2) Normal sound when refrigerant flows in pipe.

Q3) Compressor occasionally does not operate during dehumidifying.



A3) Compressor may not operate when room temperature is 10°C or less. It also stops when the humidity is preset humidity or less.

HEATING MODE

Q4) The circulation stops occasionally during Heating mode.



A4) It occurs during defrosting. Wait for 5-10 minutes until the condenser is defrosted.

Q5) When the fan speed is set at HIGH or MED, the flow is actually Weak.



A5) At the beginning of heating, the fan speed remains LOW for 30 seconds. If HIGH is selected, it switches to LOW and again to MED after additional 30 seconds.

Q6) Heating operation stops while the temperature is preset at "30".



A6) If temperature is high in the outdoor, heating operation may stop to protect internal devices.

AUTO FRESH DEFROSTING

Q7) After the ON/OFF button is pressed to stop heating, the outdoor unit is still working with the OPERATION lamp lighting.



A7) Auto Fresh Defrosting is carried out : the system checks the outdoor heat exchanger and defrosts it as necessary before stopping operation.

AUTO OPERATION

Q8) Fan speed does not change when fan speed selector is changed during auto operation.



A8) At this point fan speed is automatic.

NICE TEMPERATURE RESERVATION

Q9) When on-timer has been programmed, operation starts before the preset time has been reached.



A9) This is because “Nice temperature reservation” function is operating. This function starts operation earlier so the preset temperature is reached at the preset time. Operation may start maximum 60 minutes before the preset time.

Q10) Does “Nice temperature reservation” function operate during dehumidifying?



A10) It does not work. It works only during cooling and heating.

Q11) Even if the same time is preset, the operation start time varies.



A11) This is because “Nice temperature reservation” function is operating. The start time varies according to the load of room. Since load varies greatly during heating, the operation start time is corrected, so it will vary each day.

INFRARED REMOTE CONTROL

Q12) Timer cannot be set.



A12) Has the clock been set? Timer cannot be set unless the clock has been set.

Q13) The current time display disappears soon.



A13) The current time disappears in approx. 10 seconds. The time set display has priority.

When the current time is set the display flashes for approx 3 minutes.

Q14) The timer has been programmed, but the preset time disappears.



A14) Is the current time past the preset time? When the preset time reaches the current time, it disappears.

OTHERS

Q15 The indoor fan varies among high air flow, low air flow and breeze in the auto fan speed mode. (Heating operation)



A15 This is because the cool wind prevention function is operating, and does not indicate a fault.

The heat exchanger temperature is sensed in the auto speed mode. When the temperature is low, the fan speed varies among high air flow, low air flow and breeze.

Q16 Loud noise from the outdoor unit is heard when operation is started.



A16 When operation is started, the compressor rotation speed goes to maximum to increase the heating or cooling capability, so noise becomes slightly louder. This does not indicate a fault.

Q17 Noise from the outdoor unit occasionally changes.



A17 The compressor rotation speed changes according to the difference between the thermostat set temperature and room temperature. This does not indicate a fault.

Q18 There is a difference between the set temperature and room temperature.



A18 There may be a difference between the set temperature and room temperature because of construction of room, air current, etc. Set the temperature at a comfortable for the space.

Q19 Air does not flow immediately after operation is started.



A19 Preliminary operation is performed for one minute when the power switch on and heating or dehumidifying is set. The operation lamp blinks during this time for heating. This does not indicate a fault.

TROUBLE SHOOTING

Model RAC-25NH5, RAC-35NH5, RAC-50NH5

PRECAUTIONS FOR CHECKING



DANGER

- Remember that the 0V line is biased to 155-170V in reference to the ground level.
- Also note that it takes about 10 minutes until the voltage fall after the power switch is turned off.

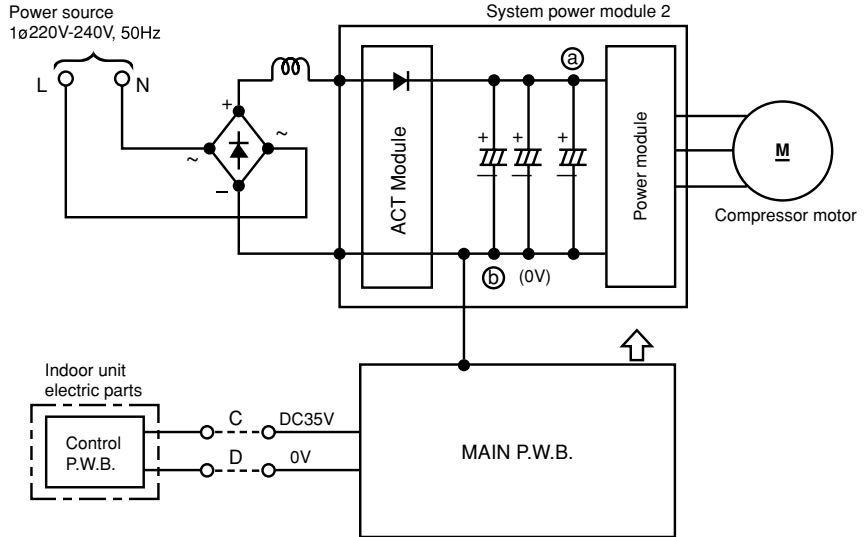

- Across (a) – (b) (0V line)..... approx 260-360V
- Across (a) – ground..... approx 155-170V
- Across (b) (0V line)– ground..... approx 155-170V



DANGER

When using an oscilloscope, never ground it. Don't forget that high voltages as noted above may apply to the oscilloscope.

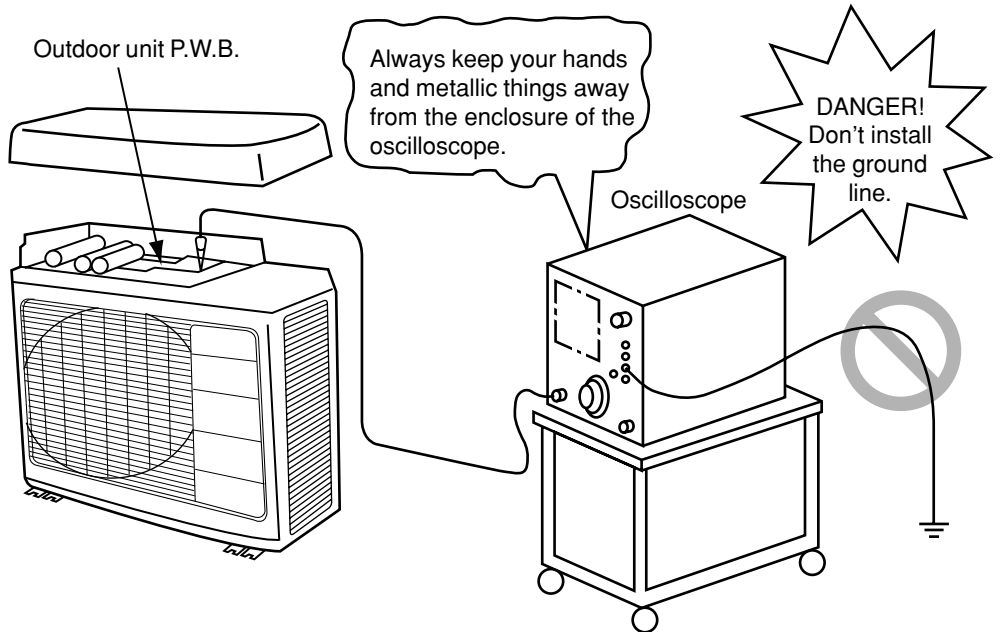

DISCHARGE PROCEDURE AND POWER SHUT OFF METHOD FOR POWER CIRCUIT



WARNING

Caution

- Voltage of about 300-330V is charged between both ends of smoothing capacitors
- During continuity check for each part of circuit in indoor unit electrical parts, disconnect red/gray lead wire connected from diode stack to system power module (SPM2) to prevent secondary trouble. (Be sure to discharge smoothing capacitor)

1. Turn OFF the Power supply to the outdoor unit.
2. After power is turned off, wait for 10 minutes or more. Then, remove electrical parts cover and apply soldering iron of 30 to 75W for 15 seconds or more to P2 and N1 terminals on system power module, in order to discharge voltage in smoothing capacitor.
3. Remove receptacle of red/gray lead wire connected to system power module from diode stack before performing operation check of each circuit.

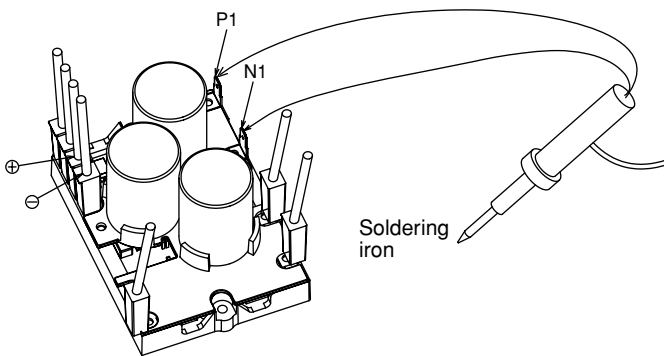

System power module

Do not use a soldering iron with transformer: If one is used, thermal fuse inside transformer will be blown

As shown above, apply soldering iron to metal parts (receptacle) inside the sleeve corresponding to P1 and N1 terminals of system power module: Do this with smoothing capacitors kept connected. By removing red/gray lead wire from diode stack, power supply can be shut off. (corresponding to ⊕ and ⊖ terminals of system power module)

RAC-25NH5, RAC-35NH5

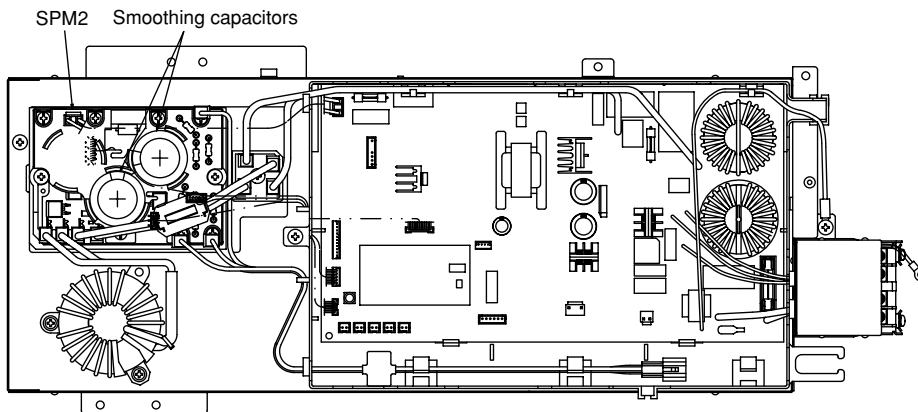

RAC-50NH5

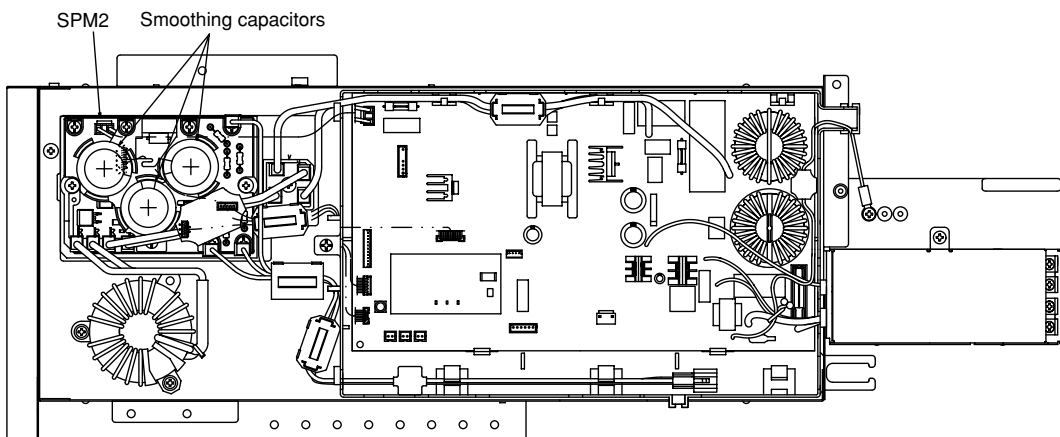

TROUBLESHOOTING WHEN TIMER LAMP BLINKS

Model RAD-18NH7A, RAD-25NH7A, RAD-35NH7A, RAD-50NH7A

Perform troubleshooting according to the number of times the indoor timer lamp and outdoor LD301 blink.

SELF-DIAGNOSIS LIGHTING MODE

Model: RAD-18NH7A, RAD-25NH7A, RAD-35NH7A, RAD-50NH7A

<Remark>

If using wired remote controller, electrical cover have to be opened so that timer lamp at indoor p.w.b can be seen as Fig. 1.

If using wireless remote controller (optional part), no need to open electrical cover. Refer the timer lamp at panel-as (Fig. 2).

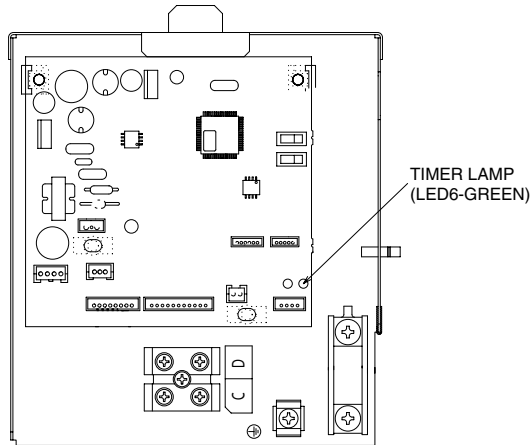

Fig. 1

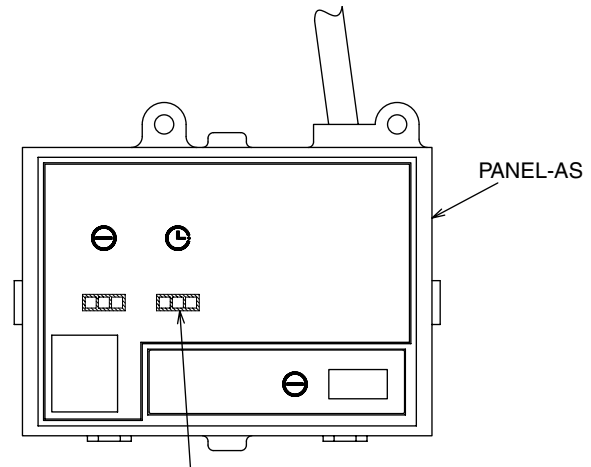

Fig. 2

No.	Timer indicator flashing mode	Reason for display	Section of estimated fault
1	2 sec. --- Once	Four-way valve faulty The room heat exchange temperature is low during heating, or it is high during cooling.	(1) Four-way valve faulty. (2) Disconnection in heat exchange thermistor (only during heating)
2	2 sec. --- Twice	Outdoor unit forced operation The outdoor unit is in forced operation or undergoing balancing after forced operation.	Service SW in outdoor electrical parts turned ON.
3	5 sec. --- 3 times	Indoor/outdoor interface faulty The interface signal from the outdoor unit has been interrupted.	(1) Indoor interface circuit (2) Outdoor interface circuit
4	2 sec. --- 4 times	Outdoor electrical assembly defective.	Please check at the outdoor electrical led lamp blinking (LD301) and refer to self diagnosis lighting mode for outdoor unit.
5	2 sec. --- 6 times	Abnormal water level detection All stop when the float switch has been activated.	(1) Drain stopped up (2) Drain pump (3) Float switch
6	2 sec. --- 7 times	Drain pump forced operation. When the knob of drain pump test switch at Indoor P.W.B main slide to 'test' position.	(1) Indoor P.W.B. Main.
7	2 sec. --- 9 times	Room thermistor or heat exchanger thermistor is faulty When room thermistor or heat exchanger thermistor is opened circuit or short circuit.	(1) Room thermistor (2) Heat exchanger thermistor
8	2 sec. --- 10 times	DC fan motor overcurrent detection Overcurrent in indoor DC fan motor has been detected.	(1) Indoor fan locked (2) Indoor fan motor (3) Indoor P.W.B. Main
※1 9	2 sec. --- 13 times	IC401 data reading fault There was error in the data read from IC401	IC401 faulty

(-- Lights for 0.35 sec. at interval of 0.35 sec..)

<Cautions>

- (1) If the interface circuit is faulty when power is supplied, the self-diagnosis display will not be displayed.
- (2) If the indoor unit does not operate at all, check to see if the connecting cable is connected or disconnected.
- (3) To check operation again when the timer lamp is blinking, you can use the remote control for operation (except for mode mark ※1).

SELF-DIAGNOSIS LIGHTING MODE

MODEL: RAC-25NH5, RAC-35NH5, RAC-50NH5



DANGER (DC360V)

- SWITCH OFF MAIN POWER SUPPLY TO THE OUTDOOR UNIT AT LEAST 10 MINUTES BEFORE START THE SERVICING WORK.
- MAKE SURE THE DC VOLTAGE LEVEL AT MEASURING POSITION (P1) AND (N1) IS LESS THAN 10V.
- DO NOT TOUCH THE SCREWS OF THE SYSTEM POWER MODULE WHEN THE UNIT IS TURNED ON. HIGH VOLTAGE STILL REMAIN EVEN AFTER THE UNIT IS TURNED OFF.
- DO NOT TOUCH ANY OTHER PARTS EXCEPT THE SERVICE SWITCH WHEN SERVICE OPERATION IS CONDUCTED.

SELF-DIAGNOSIS LIGHTING MODE ■ LIT ■ BLINKING □ OFF

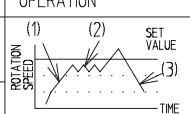
LD301	LD302	SELF-DIAGNOSIS NAME	DETAILS	MAIN CHECK POINT
□	□	[1] DURING OPERATION	COMPRESSOR OPERATION	LD303 LIGHTS, ■
□	□	NORMAL OPERATION	COMPRESSOR OPERATION	NOT MALFUNCTION
■	□	OVERLOAD (1)	 <p>UNDER OVERLOAD CONDITION, THE ROTATION SPEED IS CONTROLLED AUTOMATICALLY IN ORDER TO PROTECT THE COMPRESSOR.</p>	THIS SHOWS AN OVERLOAD, NOT MALFUNCTION.
□	■	OVERLOAD (2)		
■	■	OVERLOAD (3)		

LIGHT	MODE	[2] DURING STOP	LD303 GOES OFF. □
□	□	NORMAL STOP	INDOOR THERMOSTAT OFF. MAIN OPERATION OFF. NOT MALFUNCTION.
■	□	RESET STOP	WHEN STOPPED WITH POWER RESET. (NORMAL WHEN POWER HAS BEEN TURNED ON.)
■	□	PEAK CURRENT CUT	OVER CURRENT IS DETECTED.
■	□	ABNORMAL LOW SPEED ROTATION	POSITION DETECTION SIGNAL IS NOT INPUT DURING OPERATION.
■	□	SWITCHING FAILURE	FAIL TO SWITCH FROM INITIAL LOW FREQUENCY SYNC. TO POSITION DETECTION SYNC. .
■	□	OVERLOAD LOWER LIMIT CUT	OVERLOAD CONDITION STILL PERSISTING EVEN WHEN ROTATION SPEED IS BELOW THE LOWER RPM LIMIT.
■	□	OH THERMISTOR	OH THERMISTOR IS OPERATING.
■	□	TEMP. RISE	TEMP. RISE
■	□	ABNORMAL THERMISTOR	THERMISTOR IS OPENED OR SHORTED.
■	□	ACCELERATION DEFECTIVE	NO ACCELERATION ABOVE THE LOWER LIMIT OF THE ROTATION SPEED.
■	□	COMMUNICATION ERROR	COMMUNICATION BETWEEN INDOOR UNIT AND OUTDOOR UNIT ARE INTERRUPTED.
■	□	POWER SUPPLY VOLTAGE ERROR	POWER SUPPLY VOLTAGE IS INCORRECT.
■	□	FAN LOCK ERROR	OUTDOOR FAN RPM IS NOT ROTATE AS INTENDED RPM.
■	□	EEPROM READING ERROR	MICROCOMPUTER CANNOT READ THE DATA IN EEPROM.
■	□	ACTIVE CONVERTER DEFECTIVE	OVER VOLTAGE IS DETECTED BY SYSTEM POWER MODULE.

* EXAMPLE OF BLINKING (5 TIMES) ■■■■■ 2SEC (■) * LIGHTS FOR 0.25 SEC. AT INTERVAL OF 0.25 SEC.

WIRING DIAGRAM

BLK : BLACK GRY : GRAY
 BLU : BLUE RED : RED
 BRN : BROWN WHT : WHITE
 GRN : GREEN YEL : YELLOW

SERVICE OPERATION

COLLECT REFRIGERANT FROM INDOOR UNIT AND STORE AT OUTDOOR UNIT.

1. SWITCH OFF THE MAIN POWER SUPPLY AND THEN SWITCH IT ON AGAIN. WAIT FOR 1 MINUTE.
2. PRESS AND HOLD THE SERVICE SWITCH FOR 1 SECOND TO START OUTDOOR UNIT IN COOLING OPERATION. IN ORDER TO PREVENT PARTS FROM DAMAGE, DO NOT OPERATE THE OUTDOOR UNIT FOR MORE THAN 5 MINUTES.
3. PRESS AND HOLD THE SERVICE SWITCH FOR 1 SECOND TO STOP THE SERVICE OPERATION.
4. REPEAT STEP 1 TO 3 IF SERVICE OPERATION NEED TO BE REPEATED.

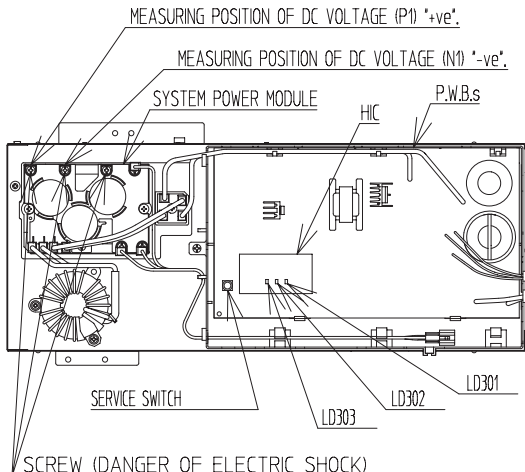

SCREW (DANGER OF ELECTRIC SHOCK)

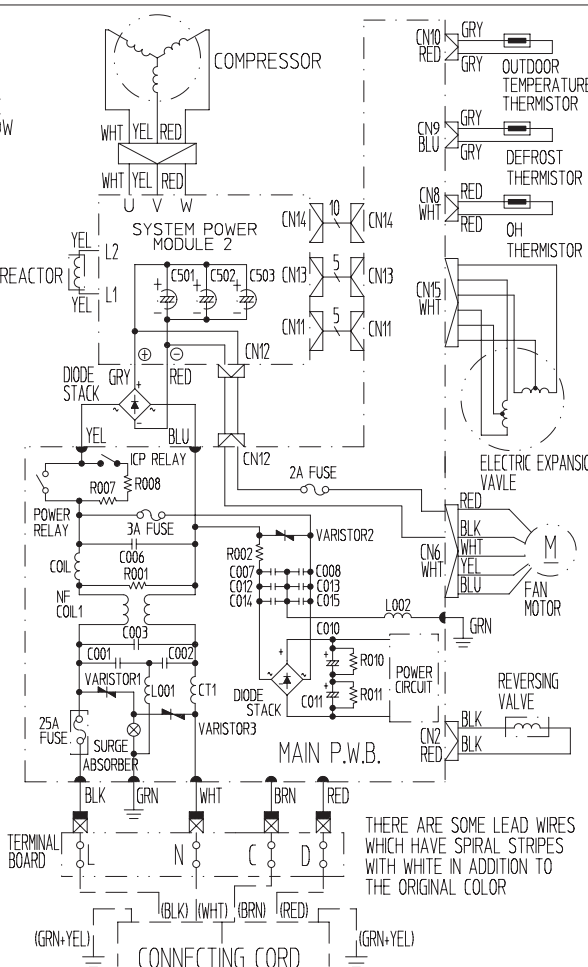

THERMISTOR: OUTDOOR TEMPERATURE THERMISTOR, DEFROST THERMISTOR, OH THERMISTOR

ELECTRIC EXPANSION VALVE

FAN MOTOR

REVERSING VALVE

CONNECTING CORD: (GRN+YEL), (BLK), (WHT), (BRN), (RED), (GRN+YEL)

THERE ARE SOME LEAD WIRES WHICH HAVE SPIRAL STRIPES WITH WHITE IN ADDITION TO THE ORIGINAL COLOR

- 92 -

CHECKING THE INDOOR/OUTDOOR UNIT ELECTRICAL PARTS AND REFRIGERATING CYCLE

Model **RAC-25NH5**
RAC-35NH5
RAC-50NH5

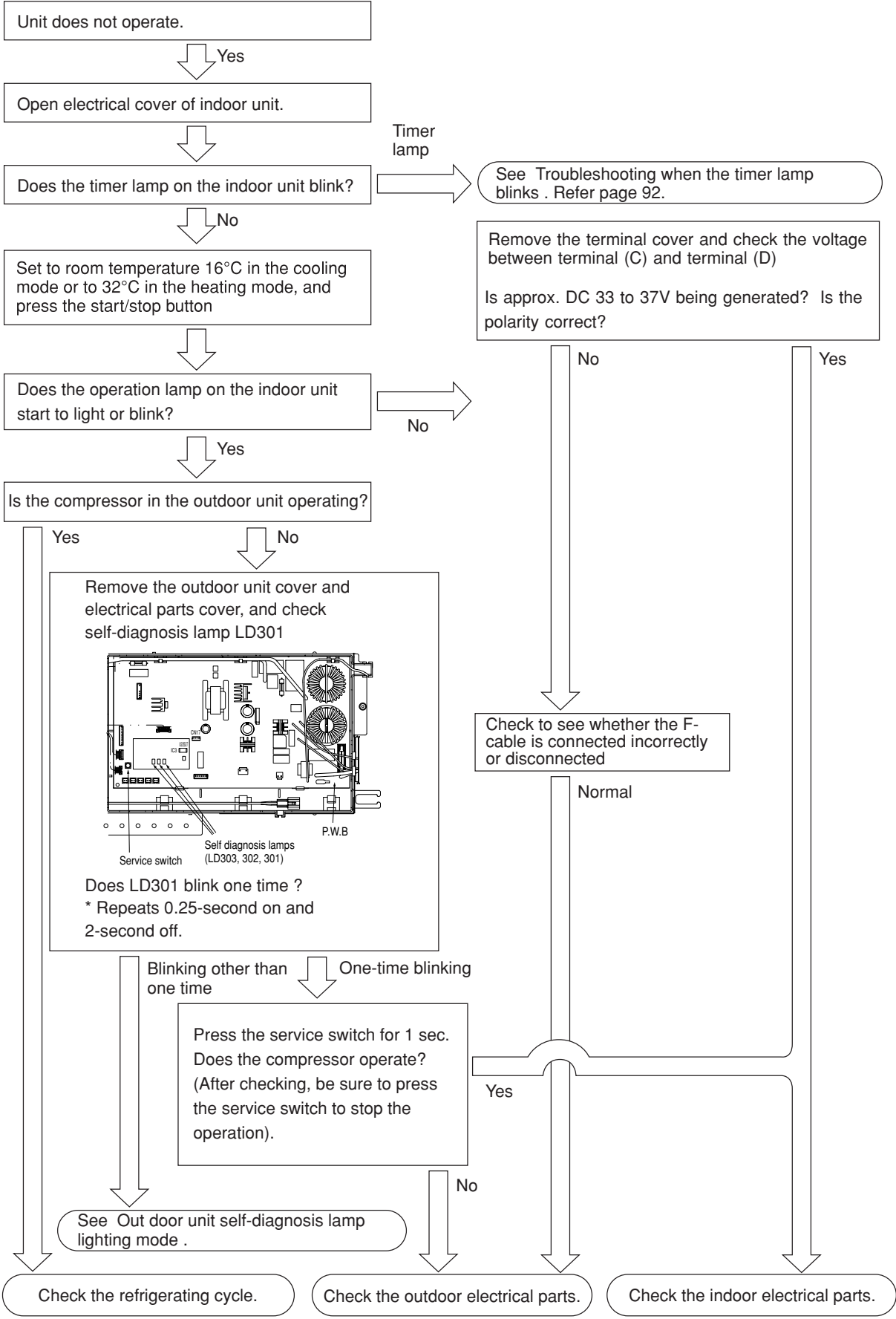

CHECKING INDOOR UNIT ELECTRICAL PARTS

1. Power does not come on (no operation)

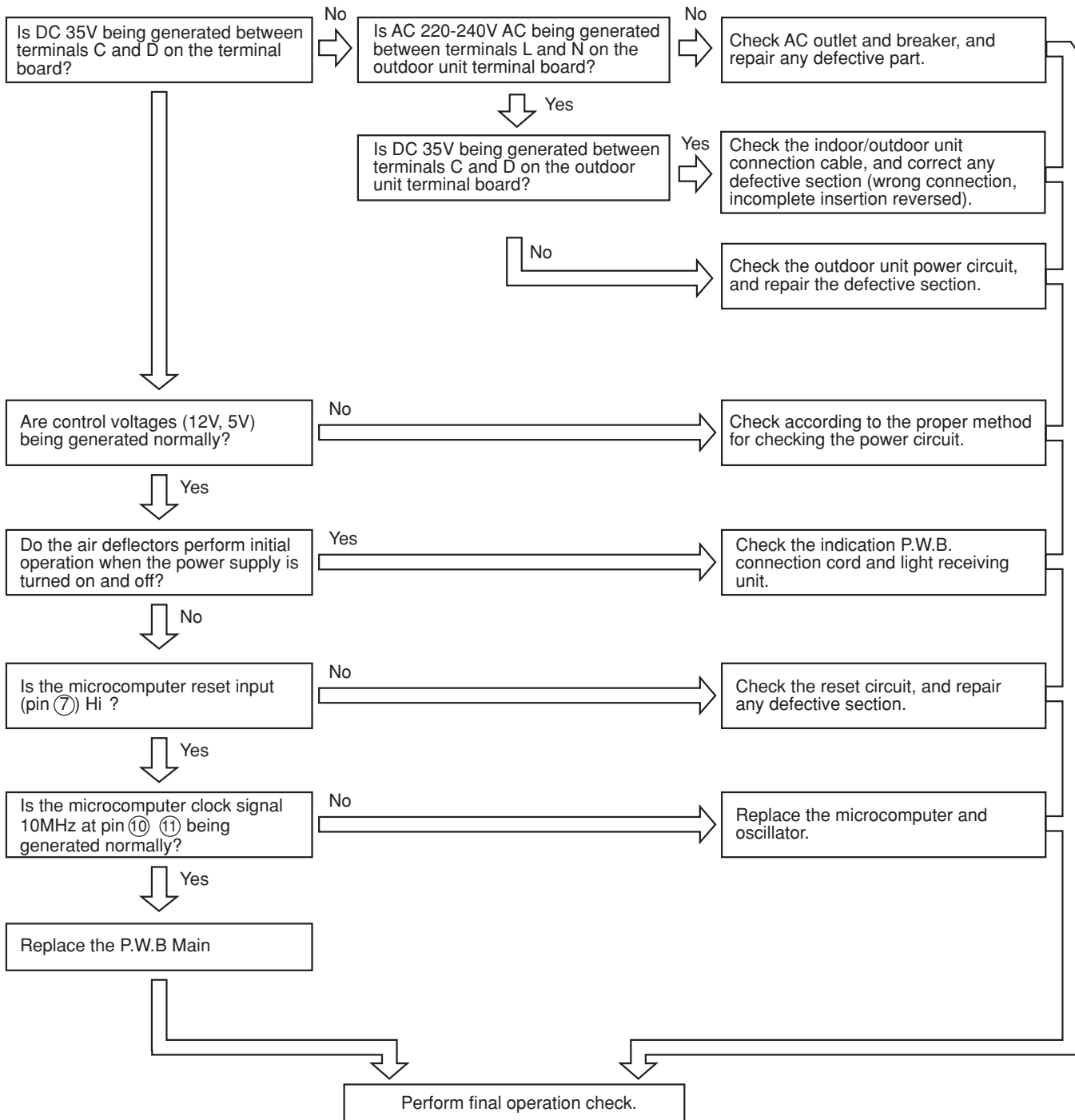

2. Outdoor unit does not operate (but receives remote infrared signal)

Set to room temperature 16°C in the cooling mode or to 32°C in the heating mode, and press the start/stop button.



Remove the outdoor unit cover and electrical parts cover, and check self-diagnosis lamp LD301.

Does LD301 blink one time?
*Repeats 0.25-second on and 2-second off.

Yes

Check the room temperature thermistor; if it is defective, replace it.
<Normal values>
10°C → approx. 20kΩ
25°C → approx. 10kΩ
30°C → approx. 8kΩ

Check the heat exchanger thermistor; if it is defective, replace it.
<Normal values>
10°C → approx. 20kΩ
25°C → approx. 10kΩ
30°C → approx. 8kΩ

No

Does outdoor electrical part LD301 blink nine times?

Yes

Is the indoor/outdoor unit communication signal superimposed on 35V DC of connection wires C and D?

No

Check outdoor electrical parts, and repair any defective parts (around the outdoor interface transmitting circuit).

Yes

Is the indoor transmitting signal being generated at Q801's collector?

No

Check the indoor interface transmitting circuit. Replace IC801.

Yes

Check outdoor electrical parts, and repair any defective parts (around the outdoor interface transmitting circuit).

No

Does LD303 switch off several second after it lights?

Yes

Check outdoor electrical parts, and repair any defective parts.



Perform final operation check.

3. Only indoor fan does not operate (other is normal)

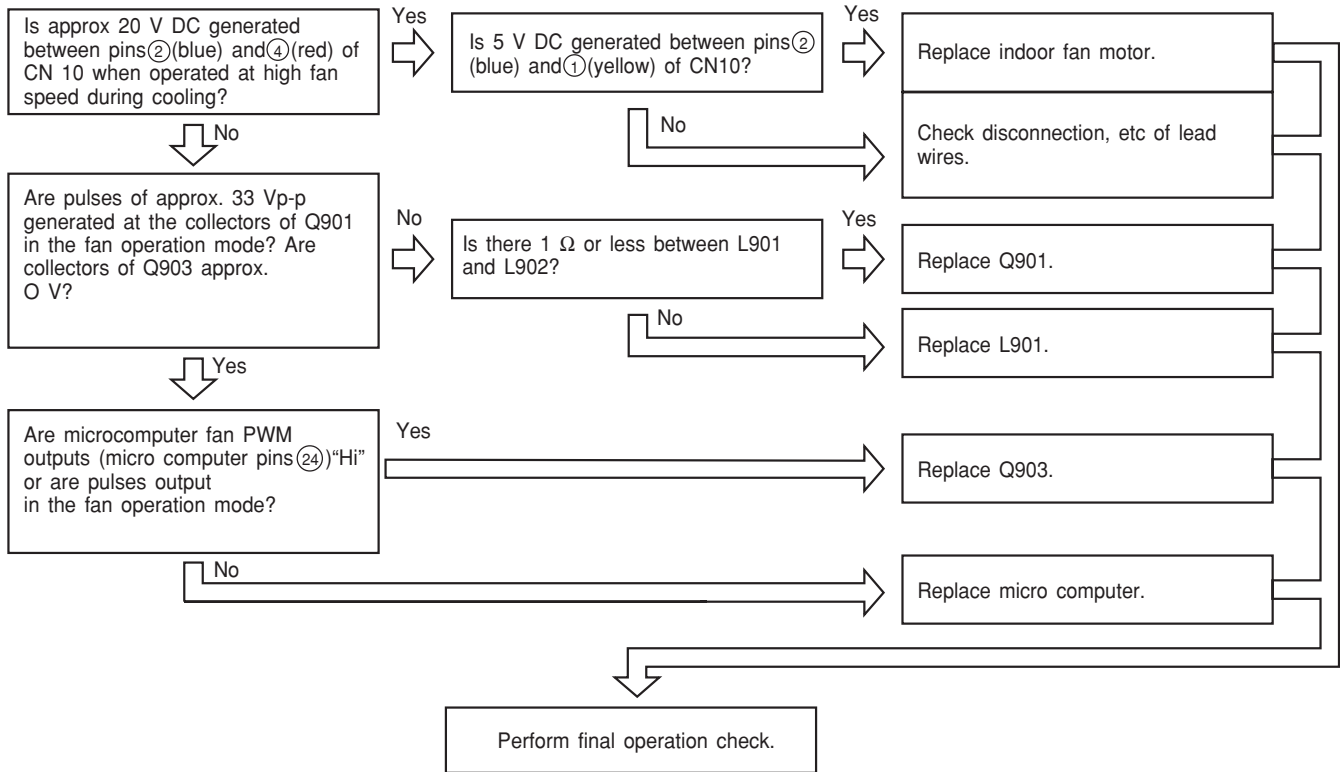

4. Indoor fan speed does not change (other is normal)

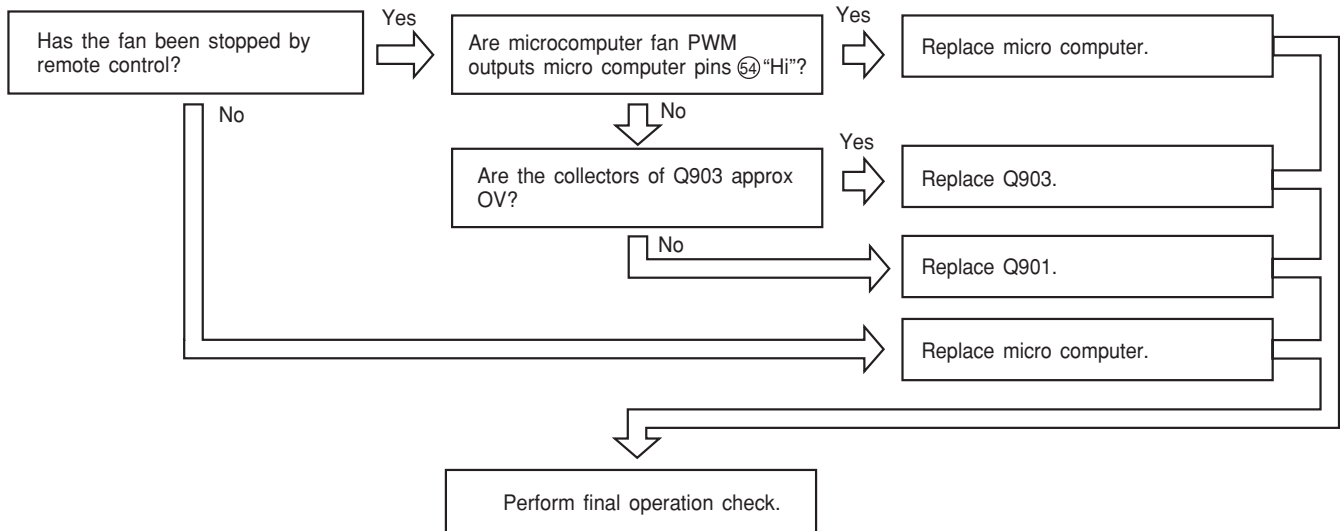

5. All systems stop from several seconds to several minutes after operation is started (all indicators are also off)

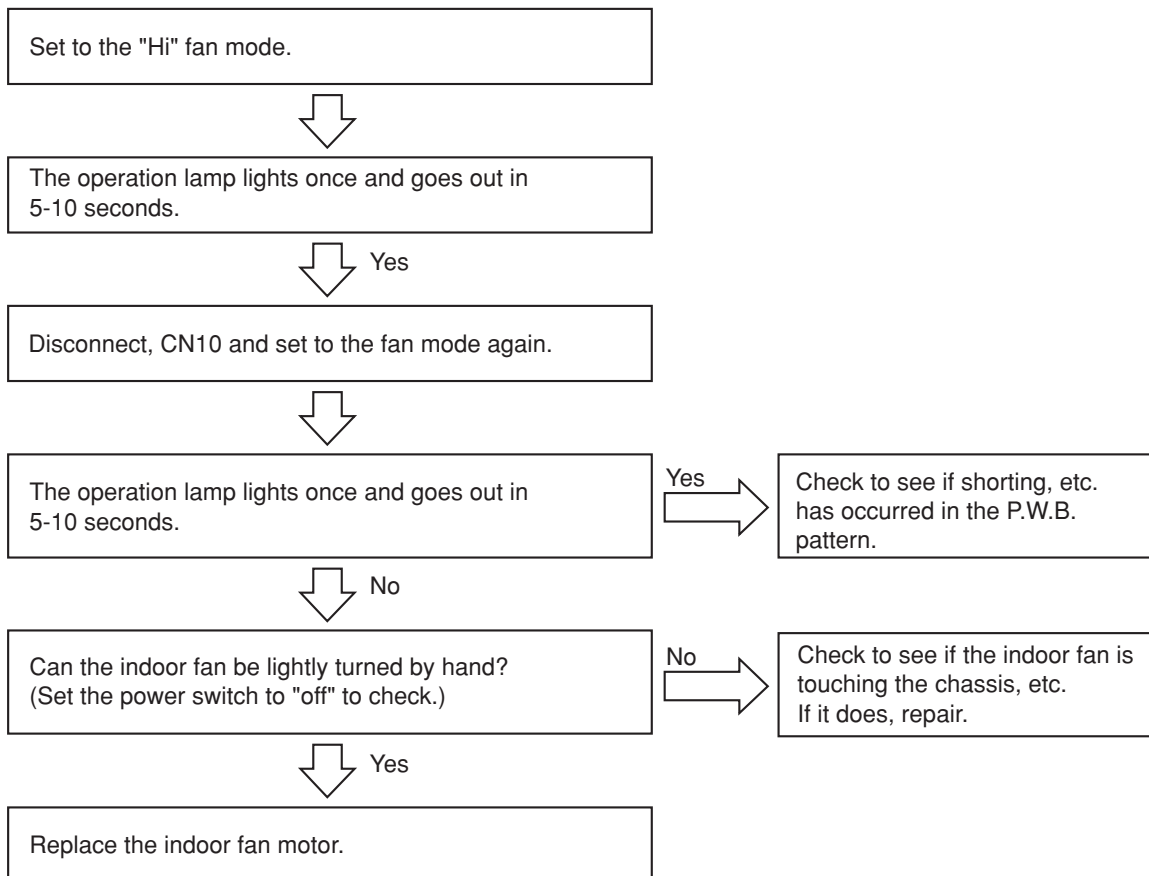

CHECKING THE OUTDOOR UNIT ELECTRICAL PARTS

MODEL RAC-25NH5, RAC-35NH5, RAC-50NH5

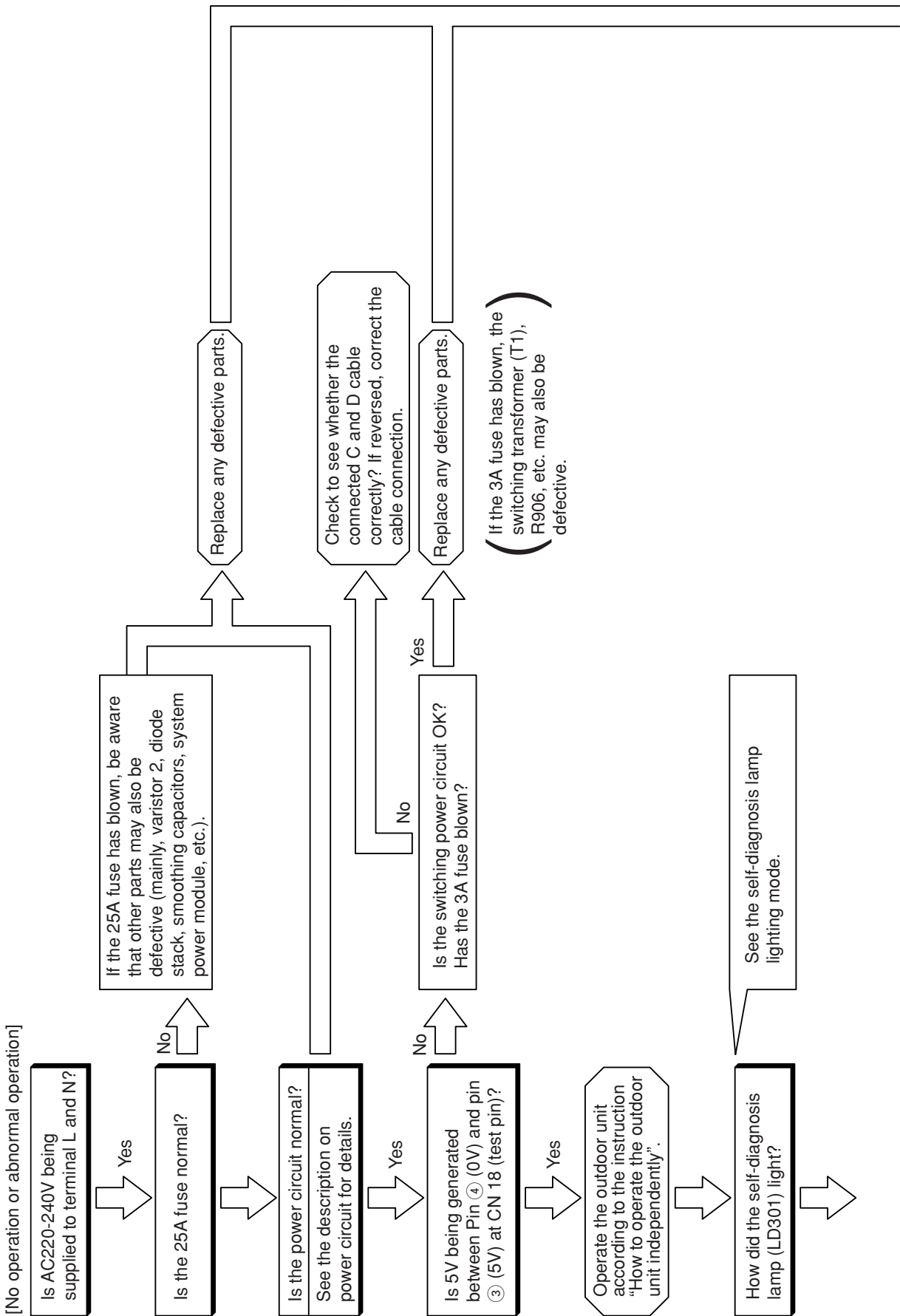

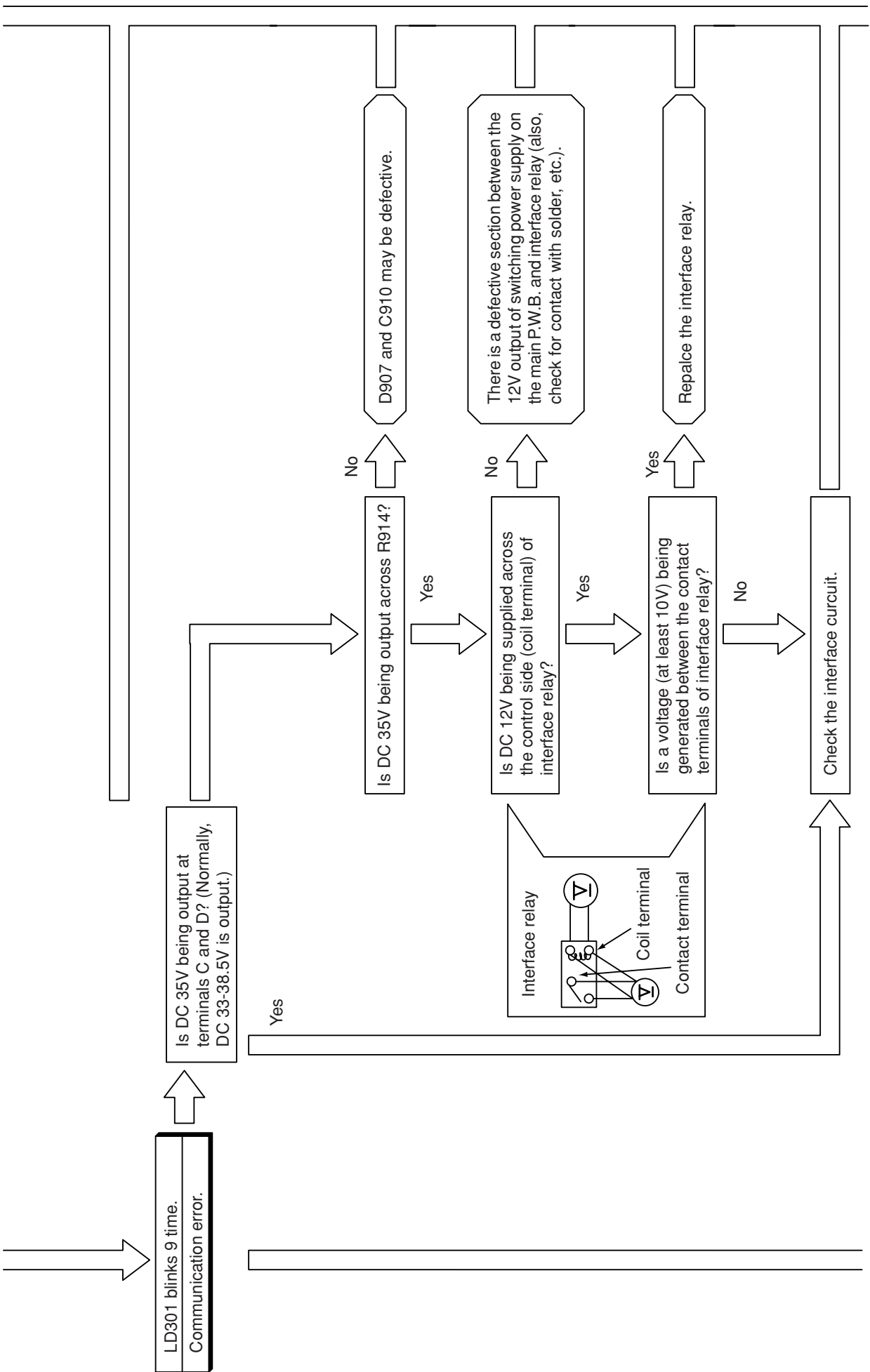

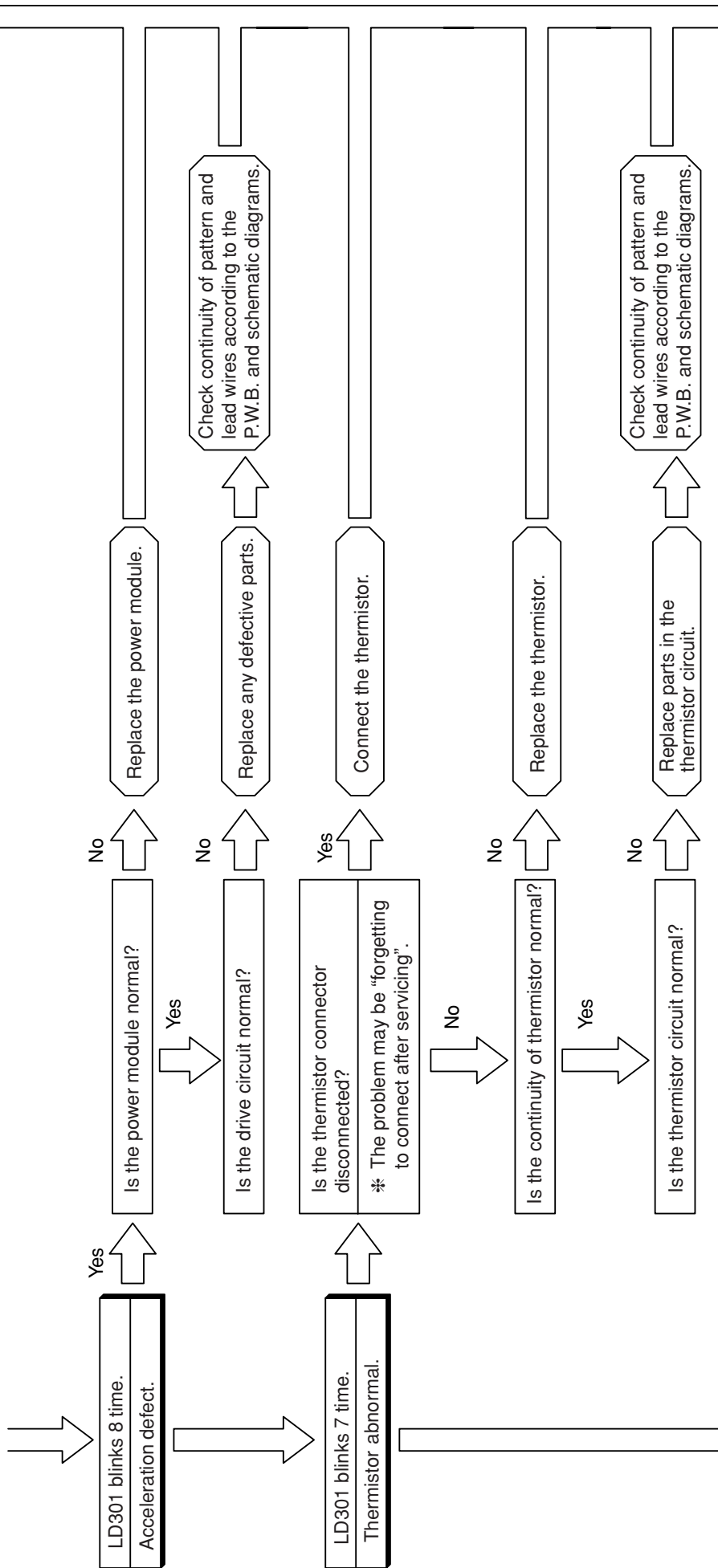

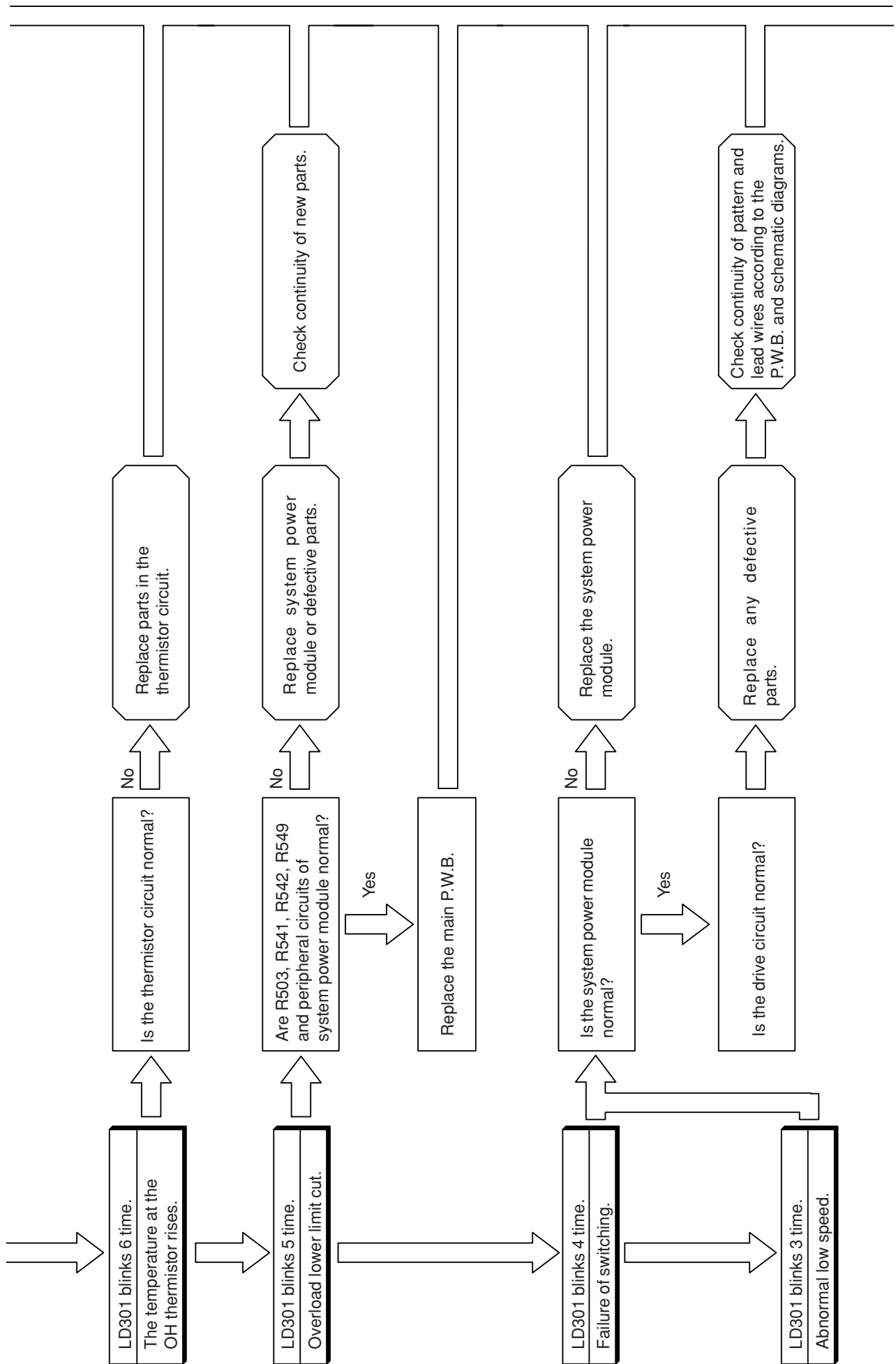

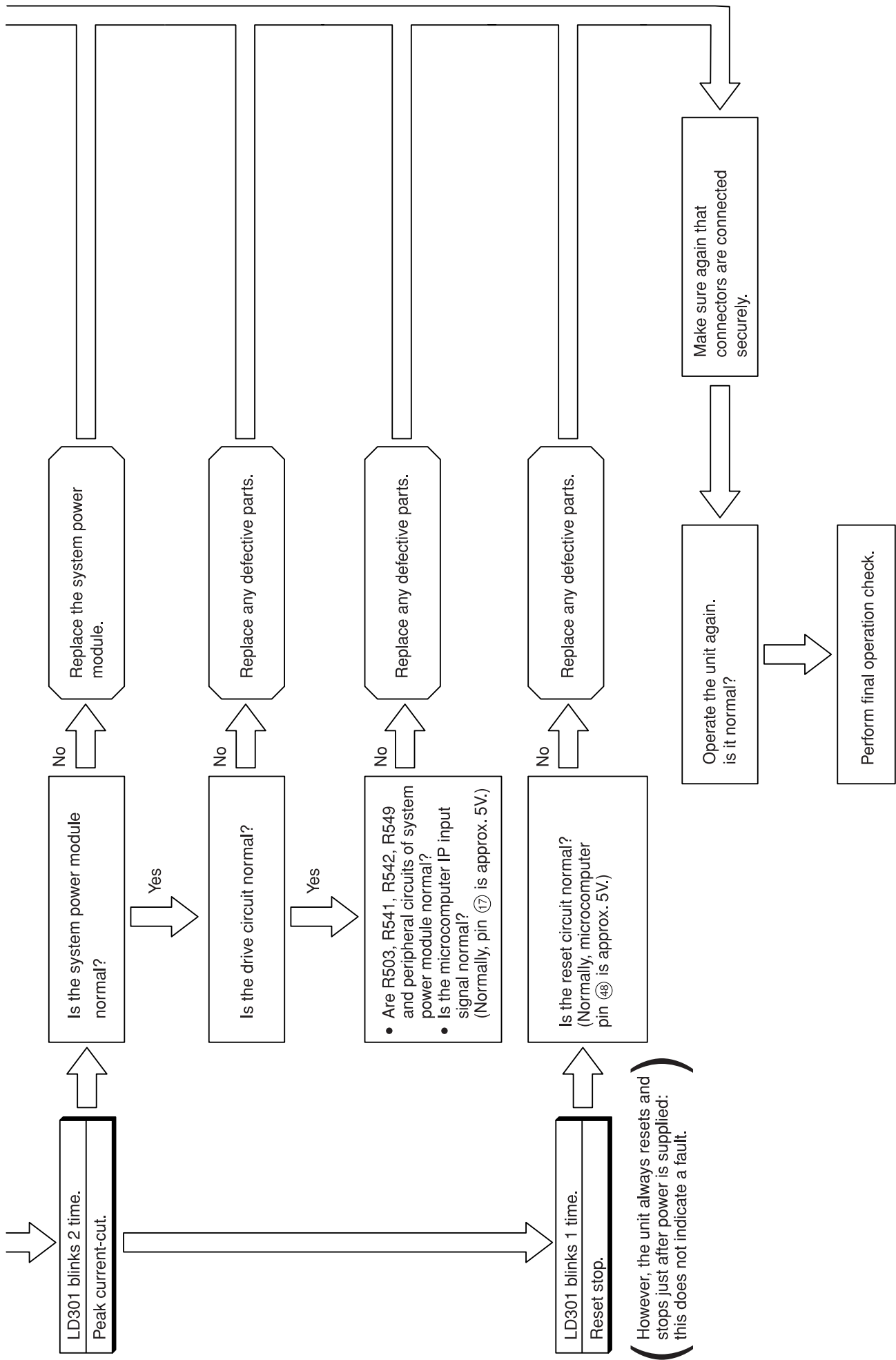

POWER CIRCUIT

Phenomenon 1 <Rotation speed does not increase>

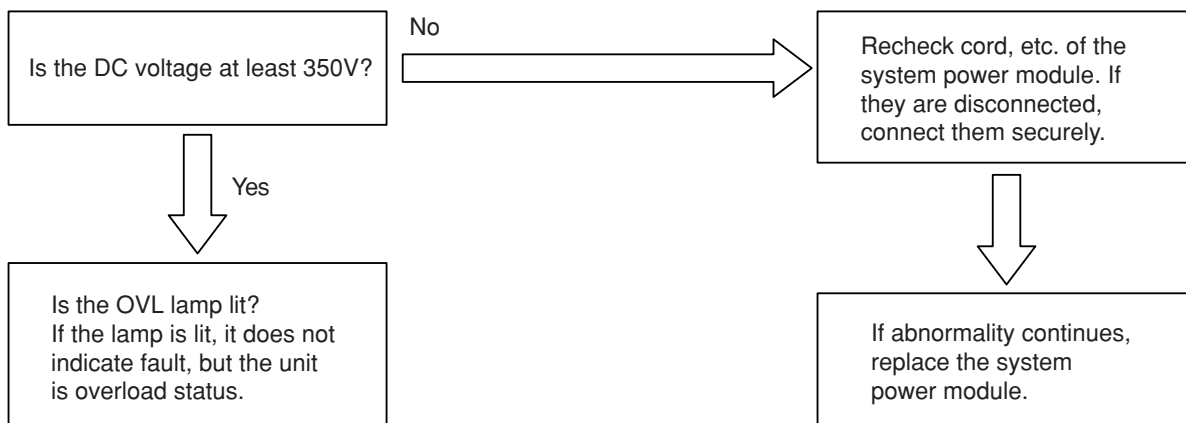

Overvoltage defect: system power module faulty (15-times blinking)

CHECKING THE REFRIGERATING CYCLE

(JUDGING BETWEEN GAS LEAKAGE AND COMPRESSOR DEFECTIVE)

1. Troubleshooting procedure (No operation, No heating, No cooling)

Connect U,V,W phase leads to the power module again and operate the air conditioner.

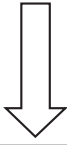

Is the self-diagnosis lamp mode as shown on the right?

Lighting mode Self-diagnosis lamp	Blinks 2 times	Blinks 3 times	Blinks 4 times	Blinks 5 times	Blinks 6 times	Blinks 8 times
LD301						
Time until the lamp lights	Approx. 10 seconds			Approx. 10 seconds	Within Approx. 30 seconds	Approx. 10 seconds
Possible malfunctioning part	Compressor				Gas leakage	Compressor

Blinking off

YES

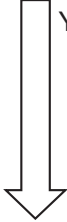

Stop to operate and check the gas pressure in balancing mode.

Normal
(0.39-0.98 MPaG)
(4-10 kg/cm²G)

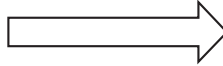

● Checking the system power module

Gas leaking
(less than 4kg/cm²G)
(less than 0.39 MPaG)



Gas leaks.
Repair and seal refrigerant.

When the self-diagnosis lamp lights in the same condition as above.

The compressor is defective. Replace it and seal refrigerant.
(If the compressor checker for an inverter type air conditioner is available, re-check using it.)

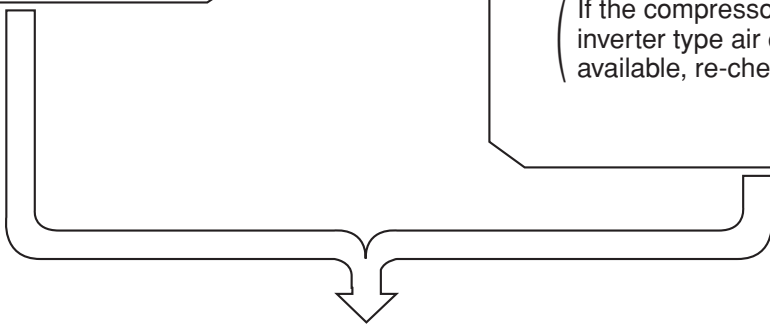

Perform a final check of operation.

HOW TO OPERATE USING THE SERVICE SWITCH THE OUTDOOR UNIT

MODEL RAC-25NH5, RAC-35NH5, RAC-50NH5

1. Turn off the power supply to outdoor unit and then turn on again.
2. Remove the electrical box cover.

LD303 (red) will light and the unit will operate in the forced cooling mode at this time.

Never operate the unit for more than 5 minutes.

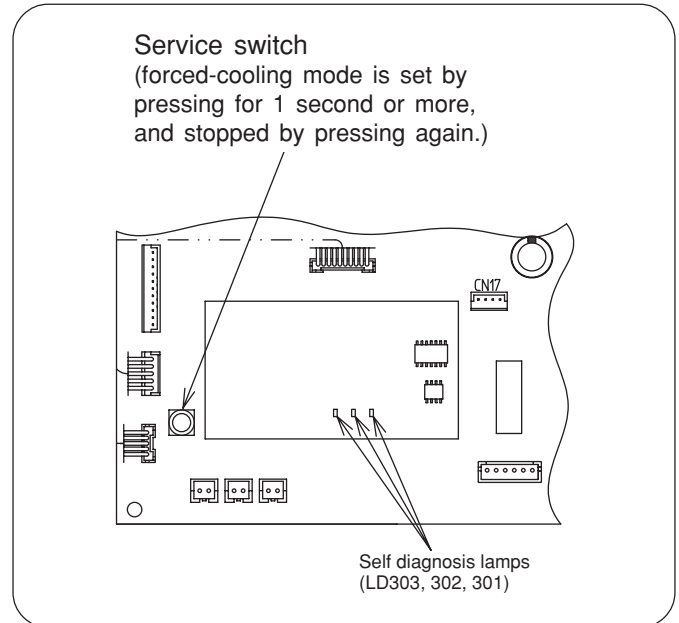
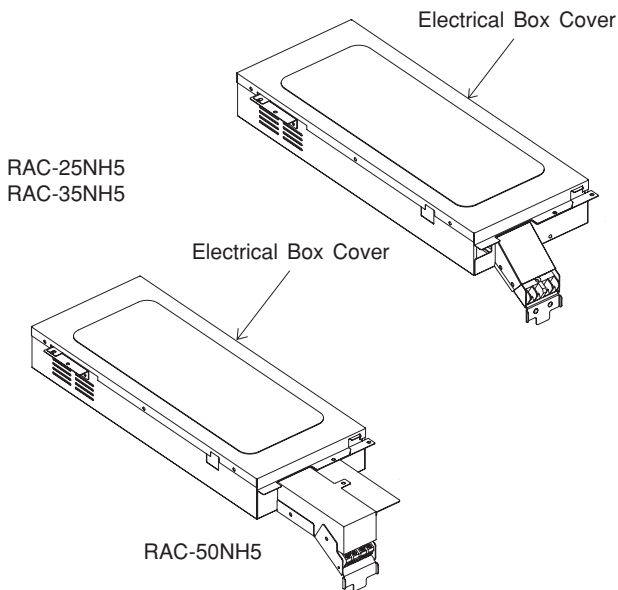

(Cautions)

- (1) If interface signal (DC 35V) terminals C and D are not connected when the outdoor unit is in forced cool mode, the outdoor unit defect indicator (LD301) will blink 9 times during operation to indicate communication error.
- (2) If checking is done with the compressor connector disconnected, the unit will continue normal operation when the electrical parts are normal, or it will repeat operating for approx. one minute and stop due to overload power limit cut, or it will operate in the overload status.

Be sure to push the service switch again to stop the forced cool operation.

HOW TO OPERATE THE OUTDOOR UNIT INDEPENDENTLY

1. Connect the large dia. pipe side and small dia. pipe side service valves using a pipe.

Connect the small diameter service valve and the large diameter service valve using the reducing union and copper pipe as shown on the right.

Charge refrigerant of 300g after vacuuming (※ 1)

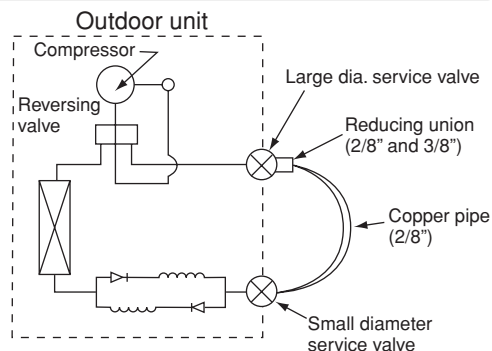

Parts to be prepared

- (1) Reducing union
2/8" (6.35mm)
1/2" (12.7mm)
- (2) Copper pipe (2/8" and 1/2")
- (3) Shorting leads
2 leads approx. 10 cm long with alligator clip or IC clip

Do not operate for more than 5 minutes

The operation method is the same as "How to operate using the connector to servicing the outdoor unit".

※ 1 The charging amount of 300g is equivalent to the load in normal operation.

SYSTEM POWER MODULE DIAGNOSIS

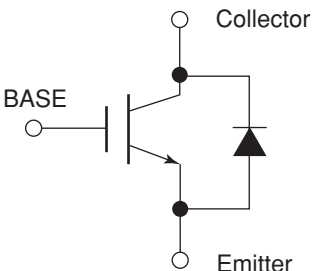
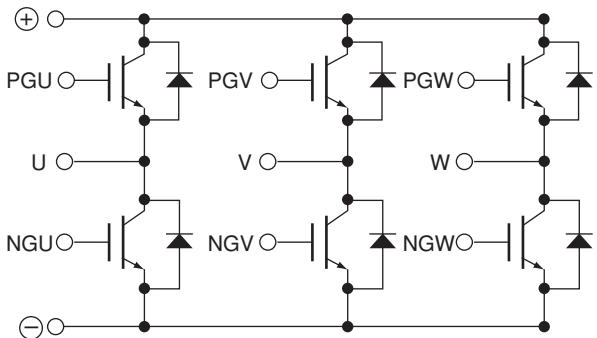
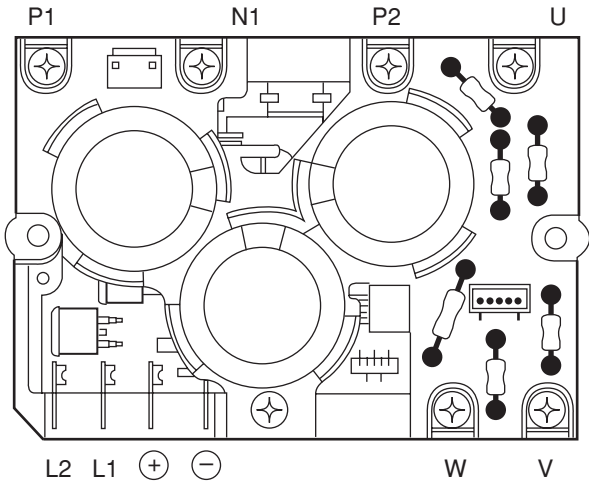
<p>Circuit diagram of the device (excepting the reflux diode)</p>	
<p>Circuit diagram of the module</p>	
<p>Terminals symbol mark of the module</p> <p>※ See next page for measuring value using tester</p>	

HOW TO CHECK SYSTEM POWER MODULE

Checking system power module using tester

Set tester to resistance range (X 100)

If indicator does not swing in the following conductivity check, the system power module is normal.

(In case of digital tester, since built-in battery is set in reverse direction, ⊕ and ⊖ terminals are reversed.)

⚠ CAUTION

If inner circuit of system power module is disconnected (open), the indicator of tester will not swing and this may assumed as normal. In this case, if indicator swings when ⊕ and ⊖ terminals are connected in reverse of diagram below, it is normal. Furthermore, compare how indicator swings at U, V and W phases. If indicator swings the same way at each point, it is normal.

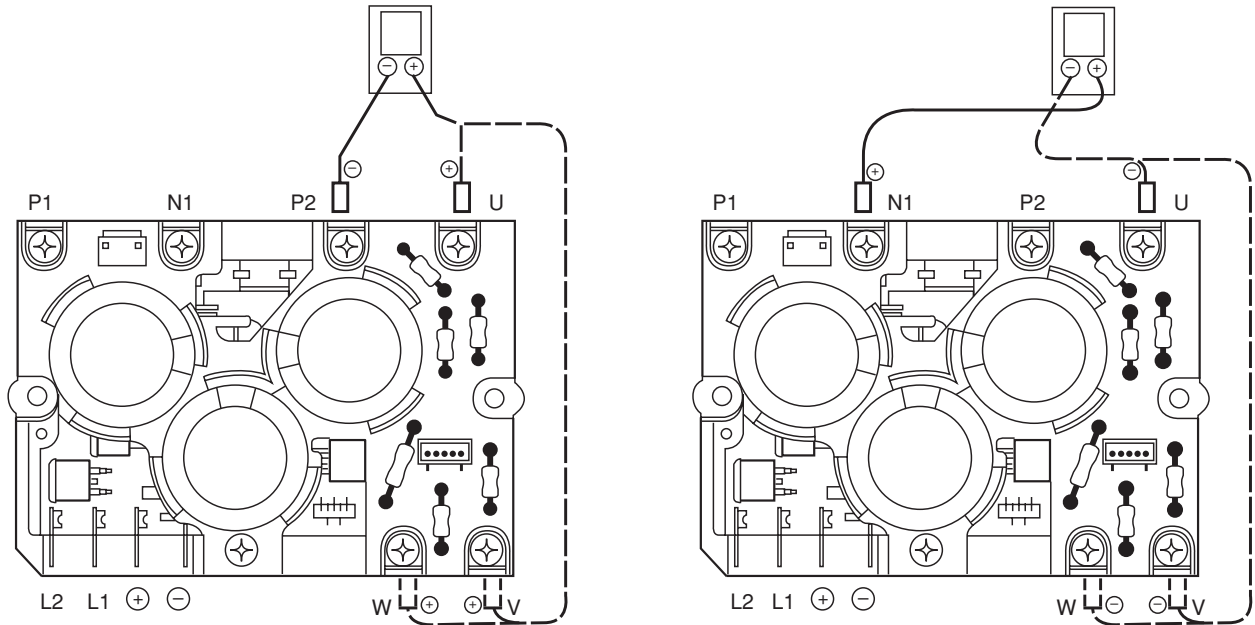

PARTS LIST AND DIAGRAM

INDOOR UNIT

MODEL : RAD-18NH7A, RAD-25NH7A, RAD-35NH7A, RAD-50NH7A

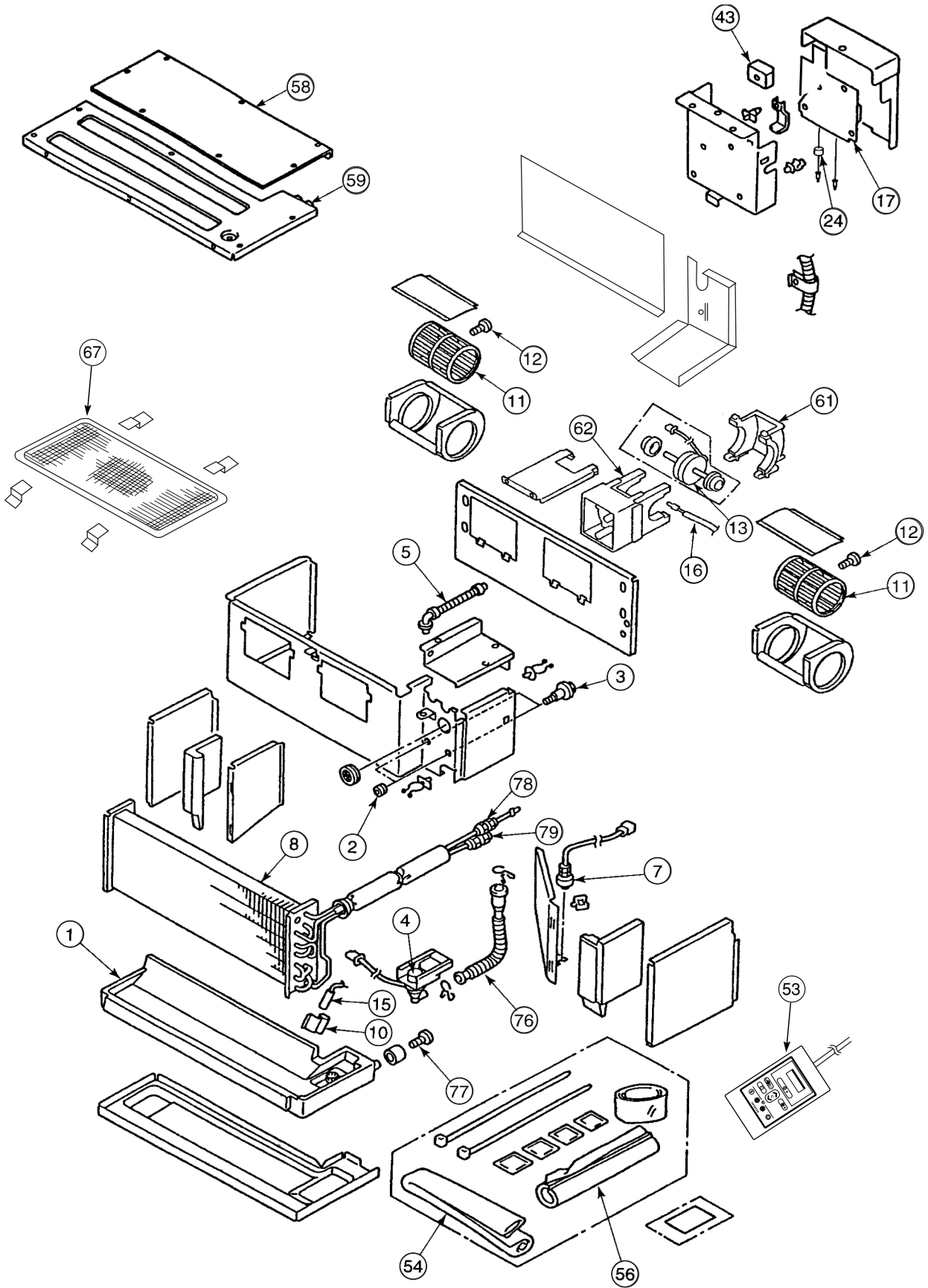

MODEL RAD-18NH7A

NO.	PART NO. RAD-18NH7A	Q'TY / UNIT	PARTS NAME
1	PMRAD-28MX R01	1	DRAIN PAN
2	PMRAMD-350BW R03	2	FAN MOTOR SUPPORT RUBBER
3	PMRAMD-350BW R04	2	SPECIAL SCREW
4	PMRAD-28MX R02	1	DRAIN PUMP
5	PMRAMD-350BW R05	1	DRAIN HOSE ASSY
7	PMRAMD-350BW R11	1	FLOAT SWITCH
8	PMRAD-18NH7 R01	1	CYCLE ASSY
10	PMRAS-10C8M R03	1	BULB SUPPORT
11	PMRAD-32CNH2 S06	2	SIROCCO FAN
12	PMRA-353B R04	2	FAN BOLT
13	PMRAD-32CNH2 S05	1	FAN MOTOR 20W, 1kg
15	PMRAMD-40GX R02	1	THERMISTOR (HEAT)
16	PMRAD-28MX R05	1	THERMISTOR (TEMPERATURE)
17	PMRAD-18NH7A S01	1	P.W.B. (MAIN)
24	PMRAC4010KX2 S08	1	FERITE CORE (935)
43	PMRAM-90QH5 901	1	TERMINAL BOARD (2P)
53	PMRAD-18NH7A R02	1	REMOTE CONTROL ASSEMBLY
54	PMRAMJ-250BW R09	1	INSULATOR PIPE
56	PMRAD-28MX R09	1	INSULATOR PIPE (236L)
58	PMRAD-18NH7 S03	1	UPPER PLATE (2)
59	PMRAD-25QH4 S04	1	UPPER PLATE (1)
61	PMRAD-28QH1 S07	1	FAN MOTOR SUPPORT
62	PMRAD-25QH4 S01	1	BASE (FAN MOTOR)
67	PMRAD-18NH7 002	1	FILTER
76	PMRAD-28MX R03	1	DRAIN PIPE
77	PMRAS5645TWU R08	1	DRAIN CAP
78	PMRAS-287AX S01	1	UNION (2)
79	PMRAS-287AX S02	1	UNION (3)

MODEL RAD-25NH7A

NO.	PART NO. RAD-25NH7A	Q'TY / UNIT	PARTS NAME
1	PMRAD-28MX R01	1	DRAIN PAN
2	PMRAMD-350BW R03	2	FAN MOTOR SUPPORT RUBBER
3	PMRAMD-350BW R04	2	SPECIAL SCREW
4	PMRAD-28MX R02	1	DRAIN PUMP
5	PMRAMD-350BW R05	1	DRAIN HOSE ASSY
7	PMRAMD-350BW R11	1	FLOAT SWITCH
8	PMRAD-18NH7 R01	1	CYCLE ASSY
10	PMRAS-10C8M R03	1	BULB SUPPORT
11	PMRAD-32CNH2 S06	2	SIROCCO FAN
12	PMRA-353B R04	2	FAN BOLT
13	PMRAD-32CNH2 S05	1	FAN MOTOR 20W, 1kg
15	PMRAMD-40GX R02	1	THERMISTOR (HEAT)
16	PMRAD-28MX R05	1	THERMISTOR (TEMPERATURE)
17	PMRAD-25NH7A S01	1	P.W.B. (MAIN)
24	PMRAC4010KX2 S08	1	FERITE CORE (935)
43	PMRAM-90QH5 901	1	TERMINAL BOARD (2P)
53	PMRAD-18NH7A R02	1	REMOTE CONTROL ASSEMBLY
54	PMRAMJ-250BW R09	1	INSULATOR PIPE
56	PMRAD-28MX R09	1	INSULATOR PIPE (236L)
58	PMRAD-18NH7 S03	1	UPPER PLATE (2)
59	PMRAD-25QH4 S04	1	UPPER PLATE (1)
61	PMRAD-28QH1 S07	1	FAN MOTOR SUPPORT
62	PMRAD-25QH4 S01	1	BASE (FAN MOTOR)
67	PMRAD-18NH7 002	1	FILTER
76	PMRAD-28MX R03	1	DRAIN PIPE
77	PMRAS5645TWU R08	1	DRAIN CAP
78	PMRAS-287AX S01	1	UNION (2)
79	PMRAS-287AX S02	1	UNION (3)

MODEL RAD-35NH7A

NO.	PART NO. RAD-35NH7A	Q'TY / UNIT	PARTS NAME
1	PMRAD-28MX R01	1	DRAIN PAN
2	PMRAMD-350BW R03	2	FAN MOTOR SUPPORT RUBBER
3	PMRAMD-350BW R04	2	SPECIAL SCREW
4	PMRAD-28MX R02	1	DRAIN PUMP
5	PMRAMD-350BW R05	1	DRAIN HOSE ASSY
7	PMRAMD-350BW R11	1	FLOAT SWITCH
8	PMRAD-18NH7 R01	1	CYCLE ASSY
10	PMRAS-10C8M R03	1	BULB SUPPORT
11	PMRAD-32CNH2 S06	2	SIROCCO FAN
12	PMRA-353B R04	2	FAN BOLT
13	PMRAD-32CNH2 S05	1	FAN MOTOR 20W, 1kg
15	PMRAMD-40GX R02	1	THERMISTOR (HEAT)
16	PMRAD-28MX R05	1	THERMISTOR (TEMPERATURE)
17	PMRAD-35NH7A S01	1	P.W.B. (MAIN)
24	PMRAC4010KX2 S08	1	FERITE CORE (935)
43	PMRAM-90QH5 901	1	TERMINAL BOARD (2P)
53	PMRAD-18NH7A R02	1	REMOTE CONTROL ASSEMBLY
54	PMRAMJ-250BW R09	1	INSULATOR PIPE
56	PMRAD-28MX R09	1	INSULATOR PIPE (236L)
58	PMRAD-18NH7 S03	1	UPPER PLATE (2)
59	PMRAD-25QH4 S04	1	UPPER PLATE (1)
61	PMRAD-28QH1 S07	1	FAN MOTOR SUPPORT
62	PMRAD-25QH4 S01	1	BASE (FAN MOTOR)
67	PMRAD-18NH7 002	1	FILTER
76	PMRAD-28MX R03	1	DRAIN PIPE
77	PMRAS5645TWU R08	1	DRAIN CAP
78	PMRAS-287AX S01	1	UNION (2)
79	PMRAS-287AX S02	1	UNION (3)

MODEL RAD-50NH7A

NO.	PART NO. RAD-50NH7A	Q'TY / UNIT	PARTS NAME
1	PMRAD-28MX R01	1	DRAIN PAN
2	PMRAMD-350BW R03	2	FAN MOTOR SUPPORT RUBBER
3	PMRAMD-350BW R04	2	SPECIAL SCREW
4	PMRAD-28MX R02	1	DRAIN PUMP
5	PMRAMD-350BW R05	1	DRAIN HOSE ASSY
7	PMRAMD-350BW R11	1	FLOAT SWITCH
8	PMRAD-50NH7 R01	1	CYCLE ASSY
10	PMRAS-10C8M R03	1	BULB SUPPORT
11	PMRAD-32CNH2 S06	2	SIROCCO FAN
12	PMRA-353B R04	2	FAN BOLT
13	PMRAD-32CNH2 S05	1	FAN MOTOR 20W, 1kg
15	PMRAMD-40GX R02	1	THERMISTOR (HEAT)
16	PMRAD-28MX R05	1	THERMISTOR (TEMPERATURE)
17	PMRAD-50NH7A S01	1	P.W.B. (MAIN)
24	PMRAC4010KX2 S08	1	FERITE CORE (935)
43	PMRAM-90QH5 901	1	TERMINAL BOARD (2P)
53	PMRAD-18NH7A R02	1	REMOTE CONTROL ASSEMBLY
54	PMRAMJ-250BW R09	1	INSULATOR PIPE
56	PMRAD-28MX R09	1	INSULATOR PIPE (236L)
58	PMRAD-18NH7 S03	1	UPPER PLATE (2)
59	PMRAD-25QH4 S04	1	UPPER PLATE (1)
61	PMRAD-28QH1 S07	1	FAN MOTOR SUPPORT
62	PMRAD-25QH4 S01	1	BASE (FAN MOTOR)
67	PMRAD-18NH7 002	1	FILTER
76	PMRAD-28MX R03	1	DRAIN PIPE
77	PMRAS5645TWU R08	1	DRAIN CAP
78	PMRAS-287AX S01	1	UNION (2)
79	PMRAS-287AX S03	1	UNION (4)

OUTDOOR UNIT

MODEL : RAC-25NH5, RAC-35NH5, RAC-50NH5

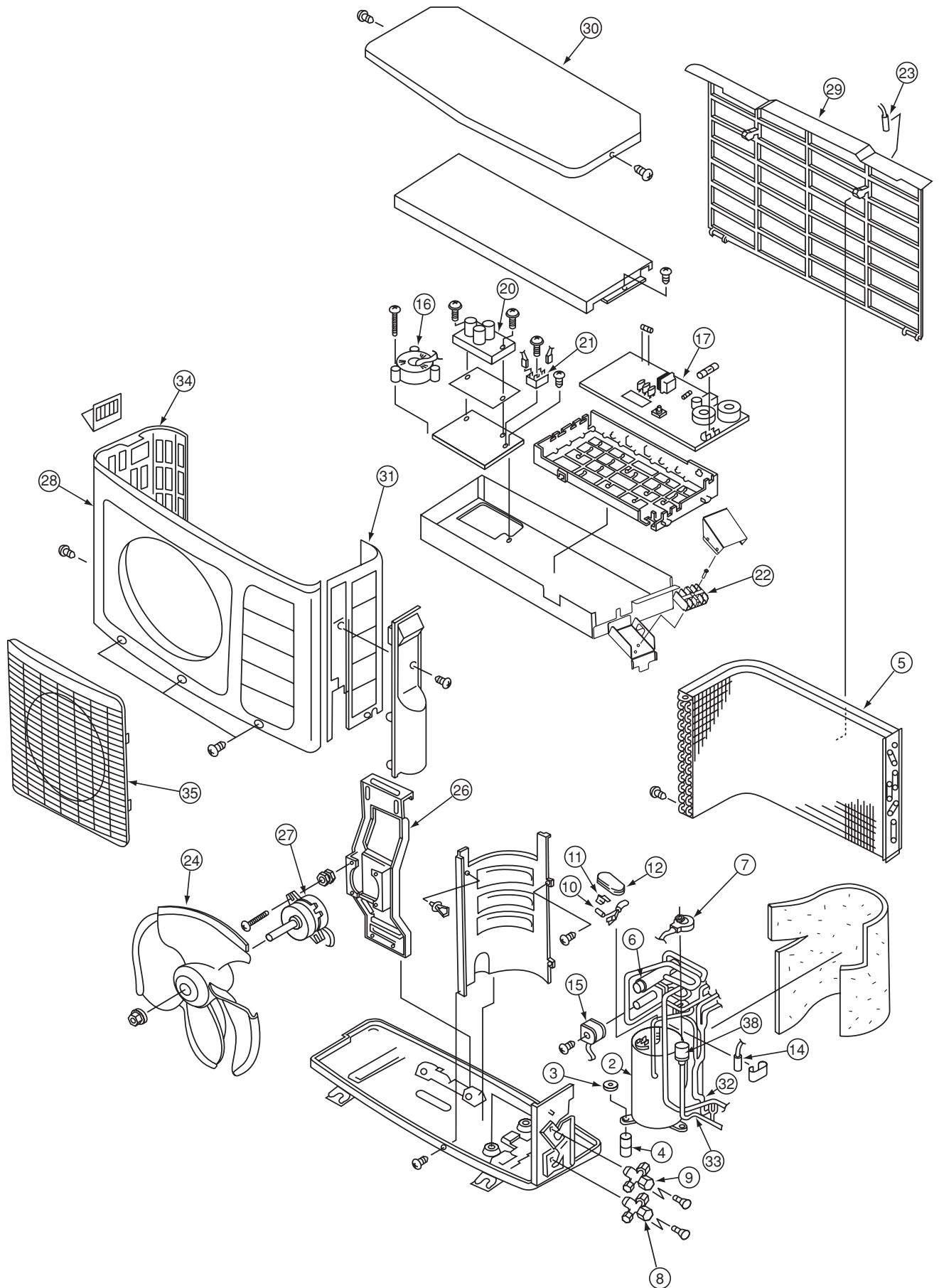

MODEL RAC-25NH5

NO.	PART NO. RAC-25NH5	Q'TY / UNIT	PARTS NAME
2	PMRAC-25NH4 S08	1	COMPRESSOR
3	KPNT1 001	6	PUSH NUT
4	RAC-2226H 805	3	COMPRESSOR RUBBER
5	PMRAC-25NH4 S01	1	CONDENSER
6	PMRAC-50YHA1 905	1	REVERSING VALVE
7	PMRAC-25NH4 S03	1	ELECTRICAL EXPANSION COIL
8	PMRAC-25NH4 S04	1	VALVE (2S)
9	PMRAC-25NH4 S05	1	VALVE (3S)
10	PMRAC-40CNH2 914	1	THERMISTOR (OH)
11	PMRAC-25NH4 S09	1	OVERHEAT THERMISTOR SUPPORT
12	PMRAC-25NH4 910	1	OVERLOAD RELAY COVER
14	PMRAC-40CNH2 915	1	THERMISTOR (DEFROST)
15	PMRAC-50YHA1 903	1	COIL (REVERSING VALVE)
16	PMRAC-18SH4 S01	1	REACTOR
17	PMRAC-25NH5 S01	1	P.W.B (MAIN)
20	PMRAC-25NH4 S12	1	SYSTEM POWER MODULE
21	PMRAC-40CNH2 902	1	DIODE STACK (D25VB60)
22	PMRAC-25NH4 S13	1	TERMINAL BOARD (4P)
23	PMRAC-40CNH2 916	1	THERMISTOR (OUTSIDE TEMPERATURE)
24	PMRAC-25CNH2 902	1	PROPELLER FAN
26	PMRAC-25NH4 S14	1	SUPPORT (FAN MOTOR)
27	PMRAC-40CNH2 919	1	FAN MOTOR (40W)
28	PMRAC-51CA1 S01	1	CABINET
29	PMRAC-51CA1 908	1	NET
30	PMRAC-51CA1 909	1	TOP COVER
31	PMRAC-25NH4 S17	1	SIDE PLATE-R
32	PMRAC-25NH4 915	1	STRAINER
33	PMRAC-25NH4 907	1	STRAINER (COND)
34	PMRAC-25NH4 917	1	SIDE PLATE-R
35	PMRAC-09CHA1 903	1	GRILL
38	PMRAC-25NH4 S16	1	EXPANSION VALVE

MODEL RAC-35NH5

NO.	PART NO. RAC-35NH5	Q'TY / UNIT	PARTS NAME
2	PMRAC-25NH4 S08	1	COMPRESSOR
3	KPNT1 001	6	PUSH NUT
4	RAC-2226H 805	3	COMPRESSOR RUBBER
5	PMRAC-25NH4 S01	1	CONDENSER
6	PMRAC-50YHA1 905	1	REVERSING VALVE
7	PMRAC-25NH4 S03	1	ELECTRICAL EXPANSION COIL
8	PMRAC-25NH4 S04	1	VALVE (2S)
9	PMRAC-25NH4 S05	1	VALVE (3S)
10	PMRAC-40CNH2 914	1	THERMISTOR (OH)
11	PMRAC-25NH4 S09	1	OVERHEAT THERMISTOR SUPPORT
12	PMRAC-25NH4 910	1	OVERLOAD RELAY COVER
14	PMRAC-40CNH2 915	1	THERMISTOR (DEFROST)
15	PMRAC-50YHA1 903	1	COIL (REVERSING VALVE)
16	PMRAC-18SH4 S01	1	REACTOR
17	PMRAC-35NH5 S01	1	P.W.B (MAIN)
20	PMRAC-25NH4 S12	1	SYSTEM POWER MODULE
21	PMRAC-40CNH2 902	1	DIODE STACK (D25VB60)
22	PMRAC-25NH4 S13	1	TERMINAL BOARD (4P)
23	PMRAC-40CNH2 916	1	THERMISTOR (OUTSIDE TEMPERATURE)
24	PMRAC-25CNH2 902	1	PROPELLER FAN
26	PMRAC-25NH4 S14	1	SUPPORT (FAN MOTOR)
27	PMRAC-40CNH2 919	1	FAN MOTOR (40W)
28	PMRAC-51CA1 S01	1	CABINET
29	PMRAC-51CA1 908	1	NET
30	PMRAC-51CA1 909	1	TOP COVER
31	PMRAC-25NH4 S17	1	SIDE PLATE-R
32	PMRAC-25NH4 915	1	STRAINER
33	PMRAC-25NH4 907	1	STRAINER (COND)
34	PMRAC-25NH4 917	1	SIDE PLATE-R
35	PMRAC-09CHA1 903	1	GRILL
38	PMRAC-25NH4 S16	1	EXPANSION VALVE

MODEL RAC-50NH5

NO.	PART NO. RAC-50NH5	Q'TY / UNIT	PARTS NAME
2	PMRAC-50NH4 S07	1	COMPRESSOR
3	KPNT1 001	4	PUSH NUT
4	RAC-2226HV 805	3	COMPRESSOR RUBBER
5	PMRAC-50NH4 S02	1	CONDENSER
6	PMRAC-50YHA1 905	1	REVERSING VALVE
7	PMRAC-25NH4 S03	1	ELECTRICAL EXPANSION COIL
8	PMRAC-50NH4 S03	1	VALVE (2S)
9	PMRAC-50NH4 S04	1	VALVE (4S)
10	PMRAC-40CNH2 S14	1	THERMISTOR (OH)
11	PMRAC-25NH4 S09	1	OVERHEAT THERMISTOR SUPPORT
12	PMRAC-25NH4 910	1	OVERLOAD RELAY COVER
14	PMRAC-40CNH2 S15	1	THERMISTOR (DEFROST)
15	PMRAC-50YHA1 903	1	COIL (REVERSING VALVE)
16	PMRAC-18SH4 S01	1	REACTOR
17	PMRAC-50YH5 S01	1	P.W.B (MAIN)
20	PMRAC-40CNH2 S01	1	SYSTEM POWER MODULE
21	PMRAC-40CNH2 S02	1	DIODE STACK (D25VB60)
22	PMRAC-25NH4 S13	1	TERMINAL BOARD (4P)
23	PMRAC-19SH4 S01	1	THERMISTOR (OUTSIDE TEMPERATURE)
24	PMRAC-40CNH2 S17	1	PROPELLER FAN
26	PMRAC-40CNH2 S18	1	SUPPORT (FAN MOTOR)
27	PMRAC-40CNH2 S19	1	FAN MOTOR (40W)
28	PMRAC-40CNH2 S04	1	CABINET
29	PMRAC-40CNH2 921	1	NET
30	PMRAC-40CNH2 922	1	TOP COVER
31	PMRAC-50NH4 S10	1	SIDE PLATE-R
32	PMRAC-50NH4 906	1	STRAINER (PIPE)
33	PMRAC-50NH4 909	1	STRAINER (COND)
34	PMRAC-40CNH2 926	1	SIDE PLATE-L
35	PMRAC-40CNH2 928	1	GRILL
38	PMRAC-25NH4 S16	1	EXPANSION VALVE

HITACHI

**RAD-18NH7A/RAD-25NH7A/RAD-35NH7A/RAD-50NH7A
RAC-25NH5/RAC-35NH5/RAC-50NH5**

PM NO. 0420E

Printed in Malaysia