

# AIR TO WATER HEAT PUMP

----- Inverter monobloc series



AS07V AS10V

**Operation, installation & maintenance manual**

V.201610

The installation of this unit is to adhere to all local  
Building Codes and Standards

# Index

Nomenclature .....	2
Working principle.....	3
Specialist Tools .....	4
Pre-installation .....	5
Installation Location .....	7
Positioning .....	8
Frost Protection.....	9
System Overview 1: Floor heating.....	10
System Overview 2: Heating ,Cooling with DHW Production with Boiler back up .....	12
System Overview 3: Multiple Units in Series Cascade Connection .....	14
Installation.....	16
Electrical connection.....	17
User Guide .....	23
Service Parameters:.....	35
Service Guide.....	36
Commissioning and Adjusting .....	48
Commissioning Form.....	50
Alarms.....	51
Maintenance .....	56
Dimensions .....	59
Water Pressure Plots.....	60
Components .....	61
Technical Specifications.....	61
Technical Specifications.....	61

# Nomenclature

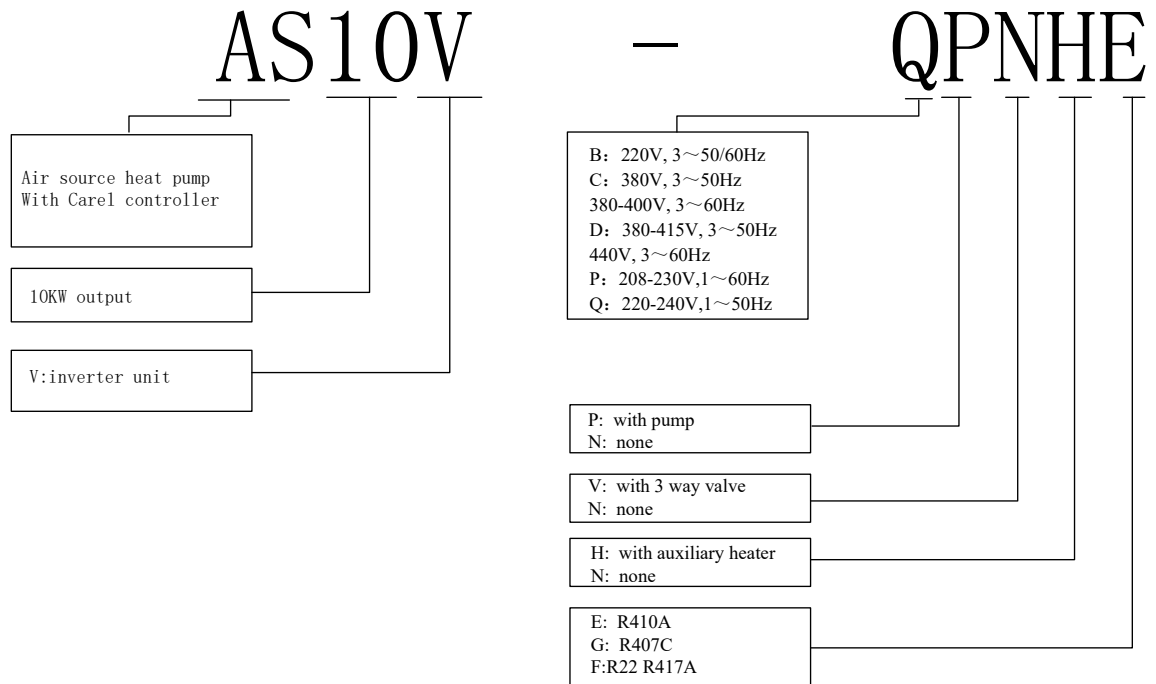

# Working principle

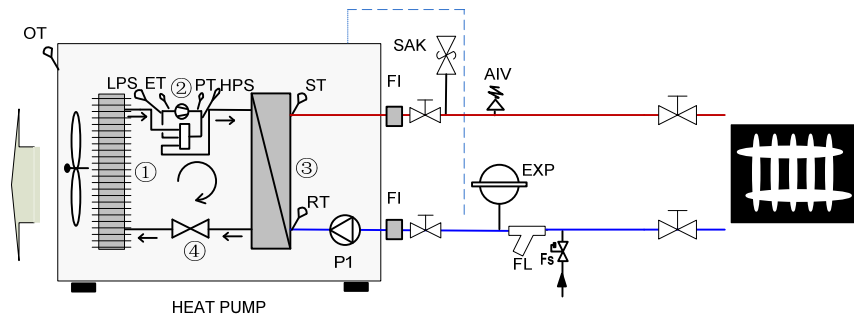

1. The low pressure and low temperature liquid refrigerant coming out of expansion valve extracts heat energy from the air through fined coil heat exchanger ① and evaporates into gas state.
2. The gas state refrigerant is sucked into compressor ② and compressed to high pressure and high temp. gas .
3. The high pressure and high temp. gas discharged by compressor releases its heat energy to water in plate exchanger ③ and condensed to liquid state.
4. The liquid state refrigerant is expanded in thermostatic expansion valve ④ and become low pressure and low temperature liquid refrigerant.
5. The cycle repeats.

# Specialist Tools

Specialist tools that might be used on installation, commissioning and maintenance.

The tools as exclusive tools for R410A refrigerant.

1 Gauge manifold ·Only for R410A

- Use the existing fitting specifications.(G1/4")
- Use high-tension side pressure of 5.3MPa·G or over.

2 Charge hose ·Only for R410A

- Use pressure performance of 5.09MPa·G or over.

3 Electronic scale

4 Gas leak detector ·Use the detector for R410A.

5. Vacuum pump (pump with reverse flow preventive function)

6 Refrigerant charge base

7 Refrigerant cylinder ·Only for R410A Top of cylinder (Pink)Cylinder with syphon

8 Refrigerant recovery equipment

9. Torque wrench

10. Multi-meter

11. screwdrivers

# Pre-Installation

## Movement and Storage

The unit must not be transported, moved or stored at greater than a 30° angle from the upright position. Store the unit in a dry area until required.

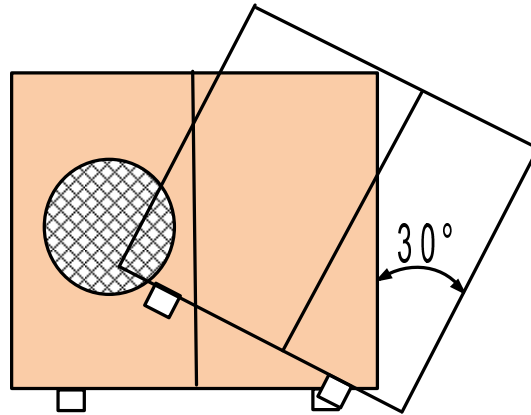

The unit must be installed by a suitably qualified tradesperson and all electrical wiring must be completed by a licensed electrical contractor in accordance with all local Standards.

## Safety

The installation must be overseen by a qualified person, in order to avoid an incorrect installation that could damage to the unit or cause injuries to people. Any faults and or leaks must be repaired immediately before the unit continues to operate. If repairs have been carried out to the unit then operation of the safety devices and parameter must be rechecked.

If a refrigerant leak occurs, remove the complete charge using a recovery unit and store the refrigerant in mobile container.

***Note: care is to be taken as the refrigerant can breakdown due to high temperature, these refrigerants by-products are dangerous.***

Once the leak has been repaired recharge the unit with the correct filling weight and the type found on the unit's nameplate.

***Note: ensure the correct refrigerant gas is used to recharge the unit as an incorrect gas can cause damage beyond repair to the compressor.***

**Do not use oxygen to purge lines or to pressurize a unit for any purpose.** Oxygen gas reacts violently with oil, grease and other common substances. Use only refrigerant or dry nitrogen for testing.

Never exceed the specified maximum operating pressures.

# Pre-Installation

Do not un-weld or flame cut the refrigerant lines including any refrigerant circuit components until the entire refrigerant (liquid and vapour) has been removed from unit. Traces of vapour should be displaced with dry nitrogen.

**Refrigerant in contact with an open flame will produce toxic gases.**

Ensure that the necessary safety protection equipment is available when servicing. Have the appropriate fire extinguishers for that system.

**Do not siphon refrigerant.**

Avoid spilling liquid refrigerant onto the skin or splashing it into the eyes. Use safety goggles. Wash any spills from the skin with soap and water. If liquid refrigerant enters the eyes, immediately and abundantly flush the eyes with water and consult medical advice.

***Note: Never apply an open flame or live stream to a refrigerant container. This can dangerously overpressure and cause an explosion.***

Compressor oil: AS07V FV50S filling 400cm<sup>3</sup>; AS10V FV50S filling 520cm<sup>3</sup>.

The heating system must be pressure tested and air vented completely.

Filling water and supplemented water must be drinking water quality (colourless, clear, free from sediments)

Filling water and supplemented water must be pre-filtered. (pore size max. 5µm)

# Installation Location

- The unit must be installed on a solid level surface on a concrete pad foundation not connected to the house foundation. Rubber cushions can be added to reduce vibration and noise if required.
- The unit should be placed so that it is well away from bedrooms or noise sensitive areas including neighbour's section boundaries. (The unit will produce noise that is above the minimum 45 decibel rating).
- The unit should be well ventilated with no obstructions and kept level at all times.
- Ensure there is good drainage around installation area and make sure this water cannot run out onto paths as it may cause ice or slime build up which is undesirable. (The unit can produce large volumes of condensation water when running in high humidity zones. There is also a large run off when the unit melts ice during a defrost cycle).
- Avoid locations exposed to machine oil vapour, salty air, thermal springs sulphur gases or other harsh substances
- If operation in temperatures below 0°C for prolonged periods or locations where the snow may fall the unit must be raised at least 300mm off the ground. This is necessary to avoid ice build-up on the unit's chassis.
- The unit must be installed level in both axes (less than 2mm tolerance per meter)
- Locations exposed to strong winds should be avoided otherwise baffles may be necessary to deflect strong winds and to prevent snow from blowing directly into the unit. They must not restrict air flow into the unit.

Indirect offshore wind

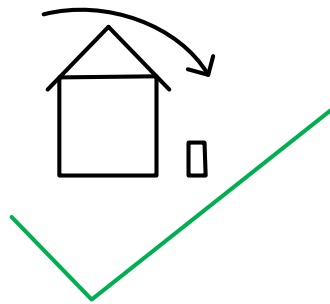

Direct offshore wind

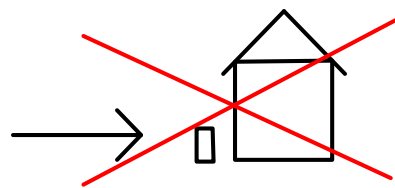

- Keep suitable distance between the unit and the building to ensure the normal running of the unit and enough room is available for maintenance.



# Positioning

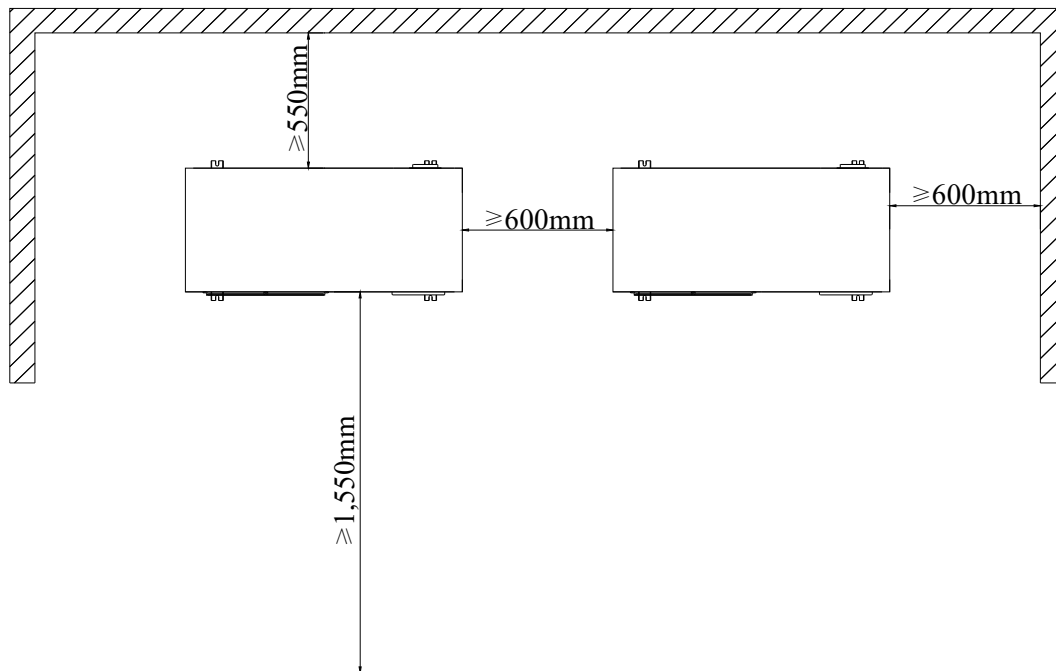

# Frost Protection

The plate heat exchanger, the piping and the hydraulic pump can be damaged by frost, despite the built-in anti-freeze protection of the unit.

In frost prone areas refer to installation location instructions.

To avoid freezing-up of the water contained in the system, one of the precautions must be taken during winter:

1. Drain the water from the system, using the drains in the lower part of the unit.
2. Add the correct percentage of glycol antifreeze to the water circuit.
3. The power to the unit must be on all the time so unit can start circulation pump and auxiliary heater for anti-freeze protection.

## ***Important***

***The pipe work must be flushed before the heat pump is connected, so that any contaminants do not damage the components parts .***

***The water pressure in the evaporator can not exceed 500 kPa or 72 PSI.***

# Systems Overview

## System Overview 1: Floor heating

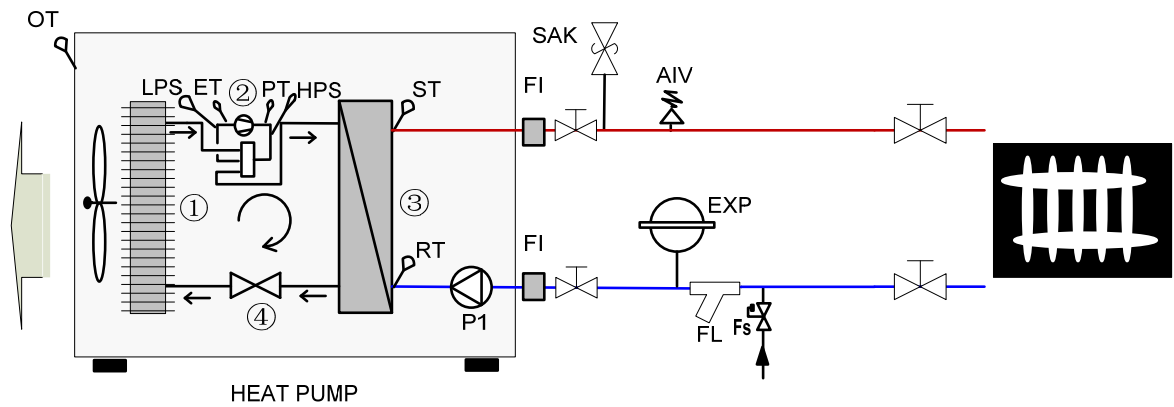

Name	Description	Included	Name	Description	Included
P1	Circulation pump	Internal	RT	Inlet water temperature sensor	Internal
AIV	Air vent valve	External	ST	Outlet water temperature sensor	Internal
FI	Soft joint	External	OT	Ambient temperature sensor	Internal
SAK	Safety valve	External	PT	Discharge gas temperature sensor	Internal
FL	Filter	External	ET	Suction gas temperature sensor	Internal
EXP	Diaphragm expansion vessel	External	HPS	High pressure transducer	Internal
FS	Automatic water supplement valve	External	LPS	Low pressure transducer	Internal

# Systems Overview

## System Overview 1: Floor heating

### Heating Mode Working Principle:

On heating mode

Unit On : when  $RT < T(\text{heating}) - ST04$  ( $T(\text{heating})$  is the control water temperature on heating mode)

Unit Off:  $RT > T(\text{heating}) + 2^{\circ}\text{C}$  and running frequency of the compressor has reduced to Minimum and lasts for 120s.

#### **T(heating) calculation:**

Default  $ST02=35, ST06=0.6$

1.) When  $SF04=\text{No}$  , there is no heating curve.  $T(\text{heating})=ST02$ .

2.) When  $SF04=\text{Yes}$ , heating curve is activated ,

$T(\text{heating}) = ST02 + (20 - OT) \times ST06$

If calculated  $T(\text{heating})$  is higher than  $ST14$  ,  $ST14$  would be  $T(\text{heating})$ .

Refer to chapter "Heating compensation curve setting" .

#### **Auxiliary Electric backup heater or boiler control**

Auxiliary backup heater or boiler only could be switched on when all of conditions below are met.

- 1.) Heating mode running and compressor has been running on the maximum workable frequency.;
- 2.) Compressor has run over 300s
- 3.)  $OT \leq ST07$ ;
- 4.)  $RT \leq T(\text{heating}) - ST04 - 2$ ;
- 5.) Compressor has run over 5 minutes.

Auxiliary backup heater or boiler is switched off when any of conditions below is met.

- 1.) A/C flow alarm.
- 2.)  $RT \geq T(\text{heating}) - 2$ ;

Auxiliary backup heater or boiler is switched on during defrosting period..

# Systems Overview

## System Overview 2: Heating ,Cooling with DHW Production with Boiler back up

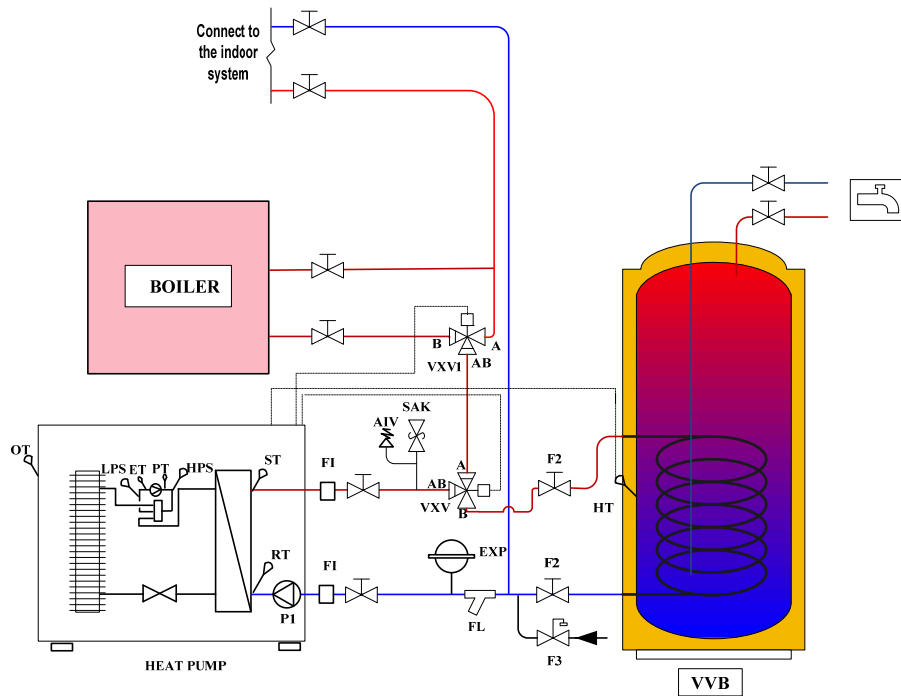

Name	Description	Included	Name	Description	Included
P1	Circulation pump	Internal	RT	Inlet water temperature sensor	Internal
VXV	3 way valve	External	ST	Outlet water temperature sensor	Internal
VVB	Hot water tank	External	OT	Ambient temperature sensor	Internal
F1	Soft joint	External	HT	Domestic hot water temperature sensor	Internal
F2	Shut-off valve	External	PT	Discharge gas temperature sensor	Internal
SAK	Safety valve	External	ET	Suction gas temperature sensor	Internal
FL	Filter	External	HPS	High pressure transducer	Internal
AIV	Air vent valve	External	LPS	Low pressure transducer	Internal
FS	Automatic water supplement	External	EXP	Diaphragm expansion vessel	External

# Systems Overview

## System Overview 2: Heating ,Cooling with DHW Production with Boiler back up

### 1. Heating Mode Working Principle:

On heating mode, Three way valve (VXV) will open AB-A.

Unit On : when  $RT < T(\text{heating}) - ST04$  ( $T(\text{heating})$  is the control water temperature on heating mode)

Unit Off:  $RT > T(\text{heating}) + 2^\circ\text{C}$  and running frequency of the compressor has reduced to Minimum and lasts for 120s.

#### T(heating) calculation:

Default  $ST02=35, ST06=0.6$

1.) When  $SF04=\text{No}$  , there is no heating curve.  $T(\text{heating})=ST02$ .

2.) When  $SF04=\text{Yes}$ , heating curve is activated ,

$$T(\text{heating}) = ST02 + (20 - OT) \times ST06$$

If calculated  $T(\text{heating})$  is higher than  $ST14$  , $ST14$  would be  $T(\text{heating})$ .

Refer to chapter "Heating compensation curve setting" .

### Auxiliary Electric backup heater or boiler control

Auxiliary backup heater or boiler only could be switched on when all of conditions below are met.

1.) Heating mode running and compressor has been running on the maximum workable frequency.;

2.) Compressor has run over 300s

3.)  $OT \leq ST07$ ;

4.)  $RT \leq T(\text{heating}) - ST04 - 2$ ;

5.) Compressor has run over 5 minutes.

Auxiliary backup heater or boiler is switched off when any of conditions below is met.

1.) A/C flow alarm.

2.)  $RT \geq T(\text{heating}) - 2$ ;

Auxiliary backup heater or boiler is switched on during defrosting period..

### 2. Cooling Mode Working Principle:

On cooling mode, Three way valve (VXV) will open AB-A.

Unit On:  $RT > T(\text{cooling}) + ST03$  ( $T(\text{cooling})$  is the control water temperature on cooling mode)

Unit Off:  $RT < T(\text{cooling}) - 1.5^\circ\text{C}$  and running frequency of the compressor has reduced to Minimum and lasts for 120s.

#### T(cooling) calculation:

Default  $ST01=13, ST08=0.6$

1.) When  $SF04=\text{No}$ , there is no cooling curve.  $T(\text{cooling})=ST01$ .

2.) When  $SF04=\text{Yes}$ , cooling curve is activated ,

$$T(\text{cooling}) = ST01 + (35 - OT) \times ST08$$

If calculated  $T(\text{cooling})$  is lower than  $ST11$  and  $ST11$  would be  $T(\text{cooling})$ .

### 3. Hot water production working principle:

On hot water mode, Three way valve (VXV) will open AB-B.

1.) When  $ST09 \leq ST20$

Compressor ON:  $HT \leq ST09 - ST10$

Compressor Off:  $HT > ST09$

2.) When  $ST09 > ST20$

Compressor On:  $HT \leq ST20 - ST10$

Compressor Off:  $HT > ST20$

Remarks: when DHW set point  $ST09$  is lower than  $ST20$ , only compressor is switched on to produce DHW.

When DHW set point  $ST09$  is higher than  $ST20$ , DHW will be heated to  $ST20$  by compressor and then electric heater instead of compressor will be switched on to heat DHW to set point.

# Systems Overview

## System Overview 3: Multiple Units in Series Cascade Connection

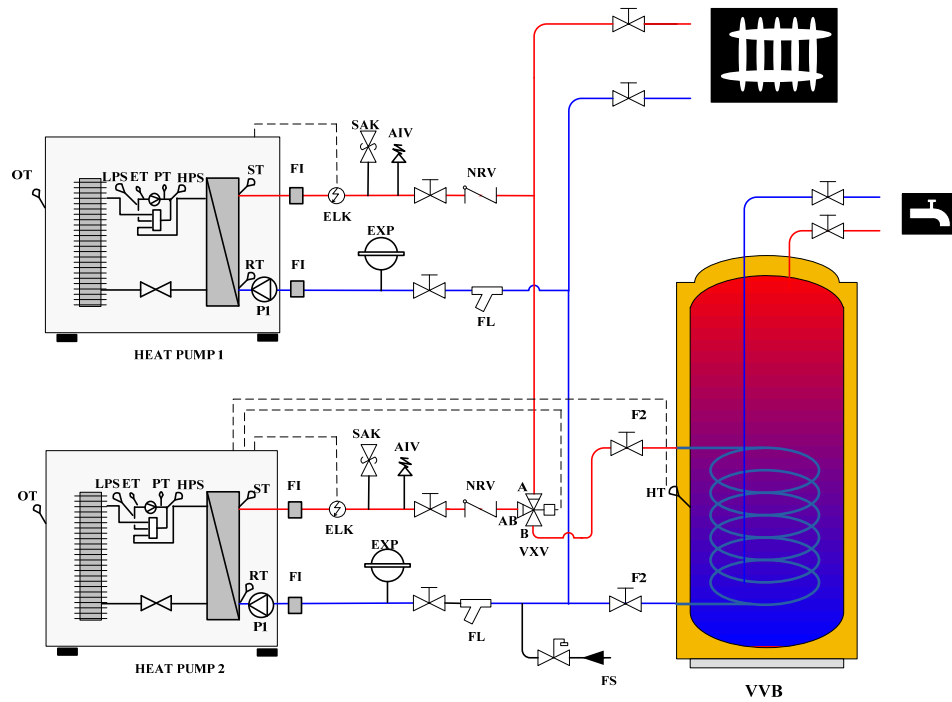

Name	Description	Included ?	Name	Description	Included ?
P1	Circulation pump	Internal	RT	Inlet water temperature sensor	Internal
VXV	3 way Valve	External	ST	Outlet water temperature sensor	Internal
VVB	Hot water tank	External	OT	ambient temperature sensor	Internal
FI	Soft joint	External	HT	Domestic hot water temperature sensor	Internal
F2	Shut-off valve	External	PT	Discharge gas temperature sensor	Internal
SAK	Safety valve	External	ET	Suction gas temperature sensor	Internal
FL	Filter	External	HPS	High pressure transducer	Internal
NRV	Non return valve	External	LPS	Low pressure transducer	Internal
ELK	Electric heater	External	EXP	Diaphragm expansion vessel	External
AIV	Air vent valve	External	FS	Automatic water supplement valve	External

# Systems Overview

## System Overview 3: Multiple Units in Series Cascade Connection

### (1) Heating working principle

To set two or more units in parallel operation, set the primary unit to the required parameters, other units could have 2~5°C difference of ST01 and ST02 to allow for energy stage control.

On heating mode, Three way valve (VXV) will open AB-A.

Unit On : when  $RT < T(\text{heating}) - ST04$  (T(heating) is the control water temperature on heating mode)

Unit Off:  $RT > T(\text{heating}) + 2^\circ\text{C}$  and running frequency of the compressor has reduced to Minimum and lasts for 120s.

#### T(heating) calculation:

Default  $ST02=35, ST06=0.6$

1.) When  $SF04=\text{No}$ , there is no heating curve.  $T(\text{heating})=ST02$ .

2.) When  $SF04=\text{Yes}$ , heating curve is activated,

$T(\text{heating}) = ST02 + (20 - OT) \times ST06$

If calculated T(heating) is higher than ST14, ST14 would be T(heating).

Refer to chapter "Heating compensation curve setting".

### Auxiliary Electric backup heater or boiler control

Auxiliary backup heater or boiler only could be switched on when all of conditions below are met.

- 1.) Heating mode running and compressor has been running on the maximum workable frequency.;
- 2.) Compressor has run over 300s
- 3.)  $OT \leq ST07$ ;
- 4.)  $RT \leq T(\text{heating}) - ST04 - 2$ ;
- 5.) Compressor has run over 5 minutes.

Auxiliary backup heater or boiler is switched off when any of conditions below is met.

- 1.) A/C flow alarm.
- 2.)  $RT \geq T(\text{heating}) - 2$ ;

### (2) DHW (domestic hot water) production working principle:

On domestic hot water mode, Three way valve (VXV) will open AB-B.

1.) When  $ST09 \leq ST20$

Compressor ON:  $HT \leq ST09 - ST10$

Compressor Off:  $HT > ST09$

2.) When  $ST09 > ST20$

Compressor On:  $HT \leq ST20 - ST10$

Compressor Off:  $HT > ST20$

Remarks: when DHW set point ST09 is lower than ST20, only compressor is switched on to produce DHW.

When DHW set point ST09 is higher than ST20, DHW will be heated to ST20 by compressor and then electric heater instead of compressor will be switched on to heat DHW to set point.



# Installation

1. The pipe installation must adhere to the local Building Code, standards and any local council requirements.
2. Ensure that the water flow and returns are correct and not reversed. Reversing the water flow will reduce the output of the unit; refer to the labels on the unit for the correct water flow direction.
3. The water pipes must not transmit any radial or axial forces to the heat exchanger. Allow some pipe flexibility between the unit and the structure to reduce any stresses and vibrations issues.
4. The water supplied to the system must be clean and not contain heavy metals that could cause harm to the unit. The water must be treated with an approved inhibitor and tested annually to prevent corrosion, fouling and deterioration of the pump fittings.
5. Protection devices are to be installed to protect the unit from operating outside of its running parameter such as control devices; shutoff valve, bleed valves, safety valves and expansion tanks.
6. The pipe installation should be designed to have the least number of elbows and joiners as they reduce flow. Install drain connections at low points to allow the system to be drain if required.
7. Flexible connections should be used where possible to reduce vibration transmission.
8. Insulate all pipe work and exposed areas to protect against both thermal heat loss and to prevent condensation on chilled pipes.
9. When filling the water system, use air vents and flushing procedure to evacuate any residual air pockets.
10. The heat pump is not fitted with shutoff valves and therefore these must be fitted outside of the heat pump to facilitate future service requirement.

# Electrical Connections

## Power Connection

Before connecting the power supply, please confirm the unit suits the power supply.

- Breaker protection must be installed according to the max value stated in the nameplate attached to the unit inside of the front panel.
- The equipment must be installed via an isolator switch with a minimum breaking gap of 3 mm.
- The power supply must conform to the specification on the unit's nameplate. The supply voltage must be within the range specified in the electrical data table. For wiring connection, refer to the electric wiring diagram on the inside panel of the unit.
- When the building is equipped with a RCD the heat pump should be equipped with a separate one.

### IMPORTANT:

During the installation of the unit, first make the water connections and then electrical connections. If the unit is to be removed first disconnect the electrical connections, then the water connections to reduce the chance of an electrical shock.

### WARNING:

Disconnect the main power supply switch before servicing the system or handling any internal parts of the unit. In case of any major malfunction turn the unit off, disconnect the mains power supply and contact a qualified service engineer.

AS07V AS10V must be connected to Single Phase power supply :

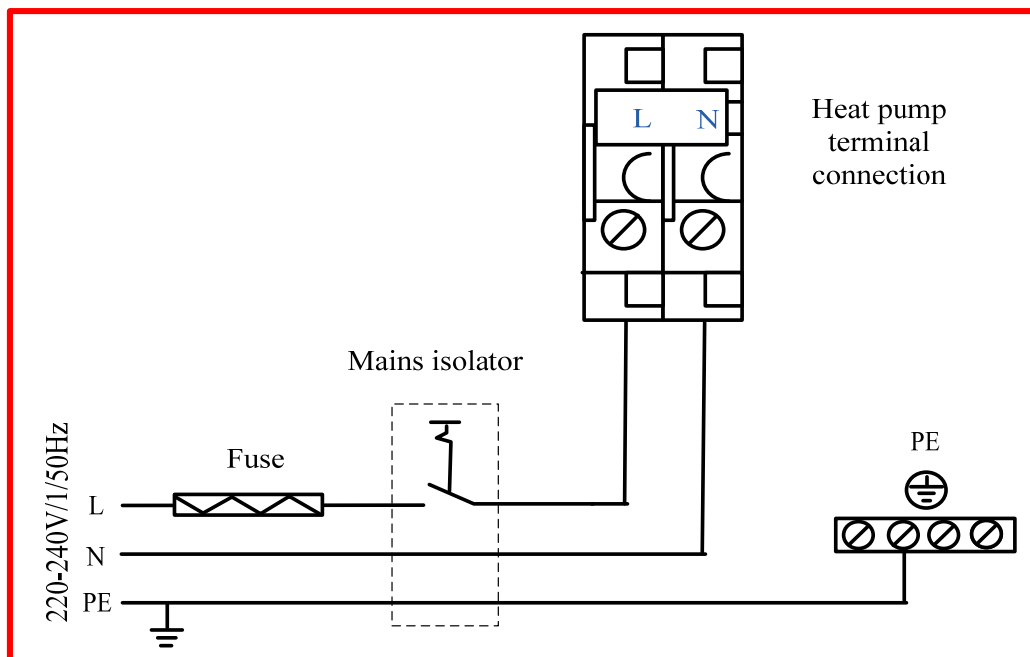

# Electrical Connections

## Temperature sensor for hot water:

The domestic hot water sensor (B4) is connected to terminal positions B4 and GND on the main board, the other terminal must be put into hot water cylinder temperature sensor probe inlet pocket if required.

If the domestic hot water sensor cable runs close to power cables, then a shielded cable should be used. If a conduit is used then it should be sealed to avoid condensation forming in the temperature sensor probe.

### ***Important:***

*All temperature sensor must be separated (min 200 mm) from high voltage power cables to avoid interference which will cause measured temperature fluctuating and the heat pump may operate incorrectly.*

## DHW circulation Pump Connection (N01)

If water in the domestic hot water pipe needs to be re-heated, a DHW circulation pump could be installed in the domestic hot water pipe that is connected to domestic hot water tank heated by the heat pump. The DHW circulation pump power supply should be connected to port (1-2) at the terminal block.

DHW circulation pump control:

- 1.) when DHW mode is switched on, DHW circulation pump will be switched on and run ST34 in every ST33 interval.
- 2.) when DHW mode is switched off, DHW circulation pump is switched off after 3 minutes' delay.

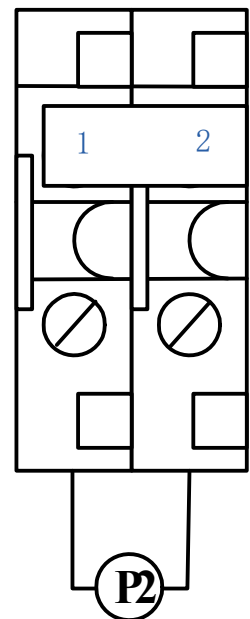

# Electrical Connections

There are two ways to turn ON/OFF heating functions.  
SF14: A/C On/Off way 1.) remote 2.) keyboard

## A/C Switch:

SF14 set to “keyboard”(factory default setting). Then the A/C switch could not control the unit any more, user interface will take over control the unit .

If SF14 set = “remote”. Keyboard can not be used to turn On/Off the heating and no heating timezone On/Off function.

B1-B2 switch is activated to turn On/Off the unit.

When the A/C switch B1-B2 is bridged via a cable, the unit’s heating function is activated. An external signal like a timer or thermostat, etc also could be connected to B1-B2 to activate or deactivate the unit’s heating function. This external signal must be voltage free.

Case 1 : Install a manual switch inside the house to switch on/off heating.

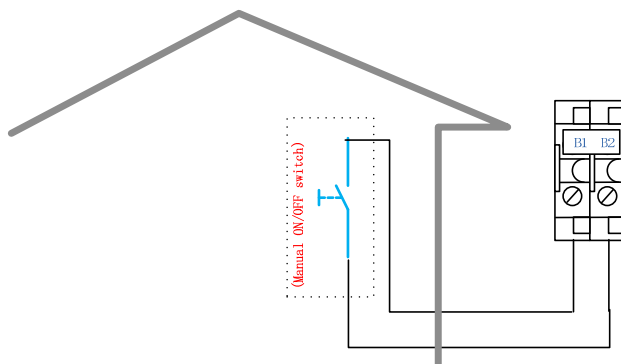

Case 2: Install a timer switch inside the house to switch on/off heating automatically

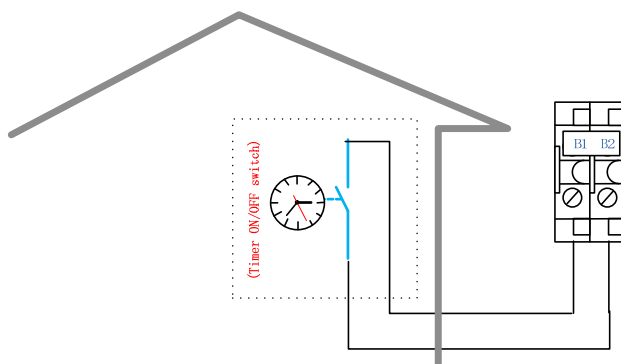

### **Note**

***This is a potential free input contact only. DO NOT PUT 230VAC INTO THIS CONTACT***

# Electrical Connections

There are two ways to turn ON/OFF domestic hot water functions.  
SF13: HW On/Off way 1.) remote 2.) keyboard

## Hot Water Switch:

When SF13 set= “remote”, Keyboard can not be used to turn On/Off the DHW and no DHW timezone On/Off function.

A1-A2 switch is activated to turn On/Off the hot water function.

hot water switch A1-A2 is bridged via a cable, the unit’s hot water function is activated. An external signal like a timer or thermostat, etc also could be connected to A1-A2 to activate or deactivate the unit’s hot water function. This external signal must be voltage free.

Case 1 : Install a manual switch inside the house to switch on/off hot water production

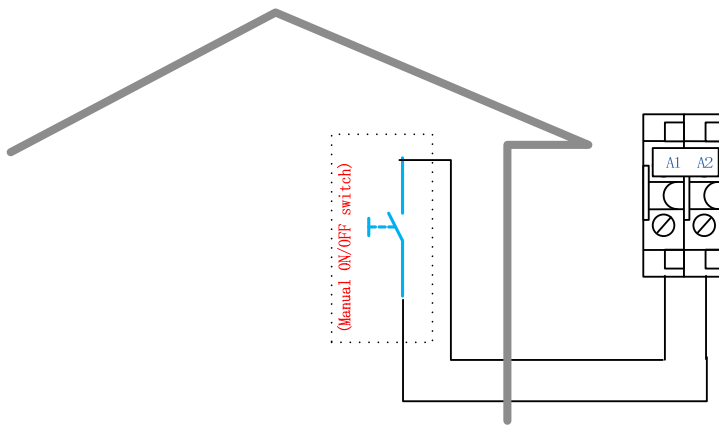

Case 2: Install a timer switch inside the house to switch on/off hot water production automatically

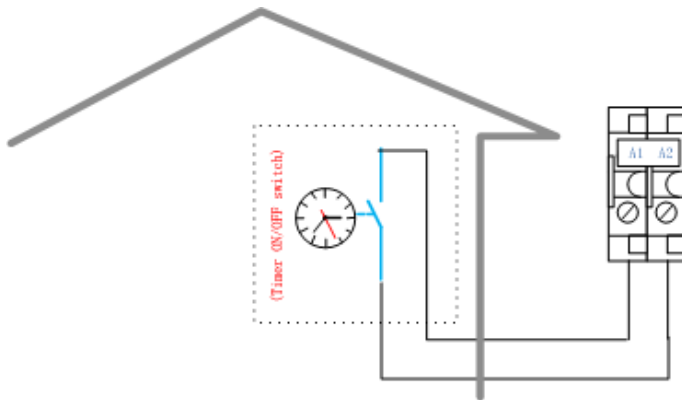

### Note

***This is a potential free input contact only. DO NOT PUT 230VAC INTO THIS CONTACT***

# Electrical Connections

## Auxiliary Electric Heater or Boiler backup and DHW heater

There is a connection port (3-4) and (5-6) which can be used to activate and de-activate an auxiliary electric heater or a boiler JQ1 for heating backup and domestic hot water heater JQ2. The max current is 1 Amps therefore a contactor must be applied to control auxiliary electric heater or boiler.

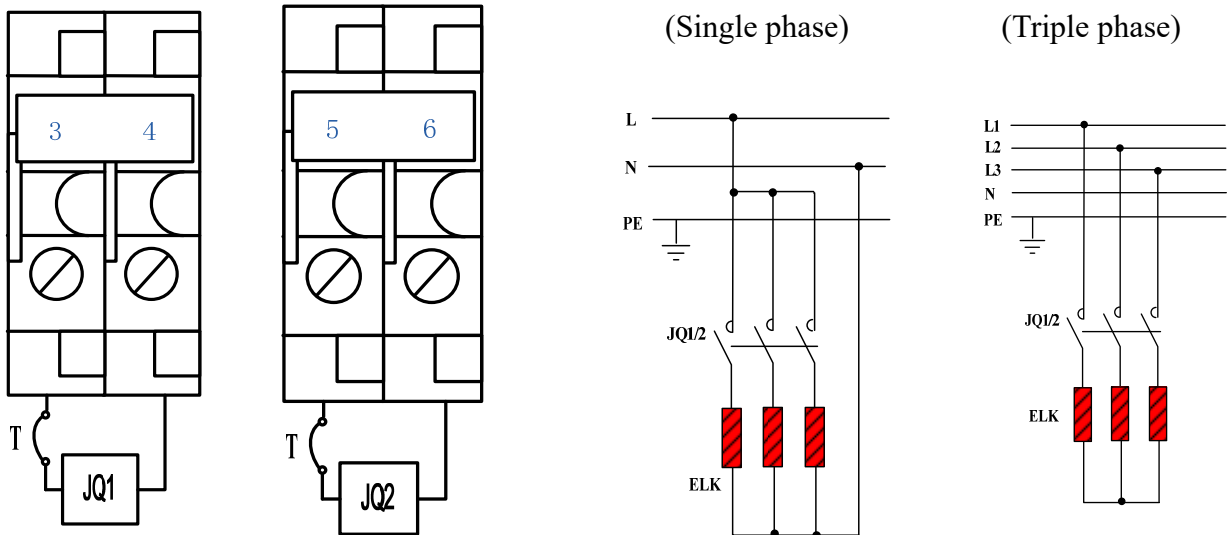

Auxiliary electric heater or a boiler running regulation refer to the chapter "system overview"

DHW electric heater control:

- 1.) If  $ST09 < ST20$ , DHW is only heated by compressor.
- 2.) If  $ST09 > ST20$ , compressor stops heating DHW after  $HT \geq ST20$ , DHW electric heater is switched on until  $HT \geq ST09$ .
- 3.) If the unit with fault and there is DHW demand, DHW heater is switched on until  $HT \geq ST09$
- 4.) DHW heater is switched on to kill bacteria until  $HT \geq ST27$  if HT is not over ST27 in ST26 time interval. If  $ST26=0$ , bacteria killing function is not valid. by default  $ST26=360$ hours.

## Three Way Valve Connection (NO7 NC7)

A 3 way valve could be connected to terminal (7-8-9)

for domestic hot water production.

The three way valve piping refer to "system overview"

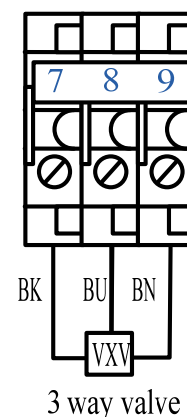

# Electrical Connections

## SG READY -Smart Grid

1.) D1-D2 (DI7) and D3-D4 (DI6) is connected to SG1 SG2 on the electric meter SG signal .

2.) TR12 parameter in Service menu are used to turn on / off unit SG function.

When TR12 is disable, SG function is invalid.

When TR12 is enable, SG function is valid. "SG mode" display on user interface. SG1 SG2 signal status display on I/O menu.

1.) DI4=1, DI5=0: switch off command

Unit has to stop. but anti-freezing function is still valid so water pump could be switched on if anti-freezing circulation is needed.

2.) DI4=0, DI5=0: normal operation .

unit runs in normal program regulation.

3.) DI4=0, DI5=1: switch-on recommendation: cheap electricity mode;

A) On heating mode, heating control water temperature automatically increase ST17 to store heating energy. but the maximum heating control water temp. is limited by ST14.

B.) On DHW mode, DHW control temperature automatically increase ST18 to store DHW energy. but the maximum DHW control temperature is limited by ST16.

C) On cooling mode, cooling control water temperature automatically decrease ST17 to store cooling energy. but the minimum cooling control water temp. is limited by ST11.

4.) DI4=1, DI5=1: switch-on command; very cheap electricity mode

A) On heating mode, heating control water temperature automatically increase ST17+2 to store more heating energy. but the maximum heating control water temp. is limited by ST14.

B.) On DHW mode, DHW control temperature automatically increase to ST16 to store maximum DHW energy. DHW electric heater ( if installed ) is switched on after compressor stops when DHW temperature reaches ST20 until DHW temperature reaches ST16.

C) On cooling mode, cooling control water temperature automatically decrease ST17-2 to store more cooling energy. but the minimum cooling control water temp. is limited by ST11.

# User Guide

## User interface

Find the user interface and connection cable from compressor room .



Standard factory delivered connection cable is 10m.

User interface should be installed indoor. It could be installed about 1.5m up from the floor ,out of reach of children.

Connect the user interface with the control board via the connection cable.

## User interface (Display window & button area)

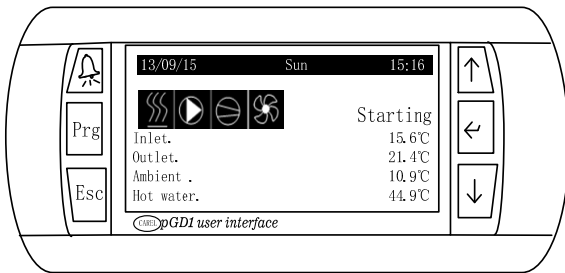

## Operating buttons

Button	Name	Operation
	<Alarm>	It will flash to indicate when any alarm happens. Press it to re-set manual re-set alarms after the fault is removed.
	<Program>	Press it to enter main menu
	<Esc>	In Menu /parameter setting mode, press it to return to the previous menu level.
	<Enter>	In Menu/parameter setting mode, press it enter the menu , or the value entered or scroll to next parameter data.
	<Up>	Press it to scroll to another menu or to increase the value in Menu/parameter setting mode
	<Down>	Press it to scroll to another menu or to decrease the value in Menu/parameter setting mode On stop, standby or On mode, press it to read actual temp. from inlet water temp. to outlet water temp.....



# User Guide

## Symbol explanation

	Heating mode
	Cooling mode
	Domestic hot water mode
	Domestic hot water mode + Heating mode
	Domestic hot water mode + Cooling mode
	Water pump
	Compressor
	Fan

## Menu Tree

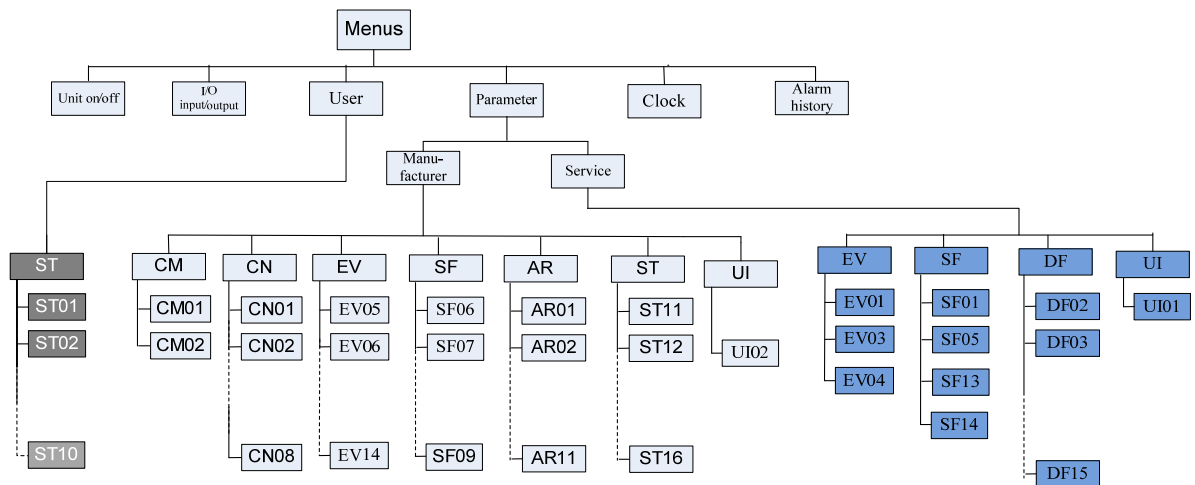

Code	Indication	Code	Indication
CM	Compressor settings	ST	Setpoints
CN	Condenser settings	UI	User interface
EV	Evaporator settings	AR	Alarm settings
SF	Special functions	DF	Defrost settings

# User Guide

## Access Rights

Three groups of users with different privilege levels are described below.

Privilege Level	Main Activities <i>Special</i>	All
Manufacturer	<ul style="list-style-type: none"> <li>• Password required</li> <li>• Configure and commission applications by setting/adjusting parameter values</li> </ul>	<ul style="list-style-type: none"> <li>• View information and status</li> <li>• Acknowledge warnings and alarms</li> <li>• Heating /Cooling changeover</li> </ul>
Service	<ul style="list-style-type: none"> <li>• Password required</li> <li>• Configure and commission applications by setting/adjusting parameter values</li> </ul>	
User	<ul style="list-style-type: none"> <li>• No password is required</li> <li>• Adjust User parameters</li> </ul>	

### ● Main menu:

Press  button to enter main menus:

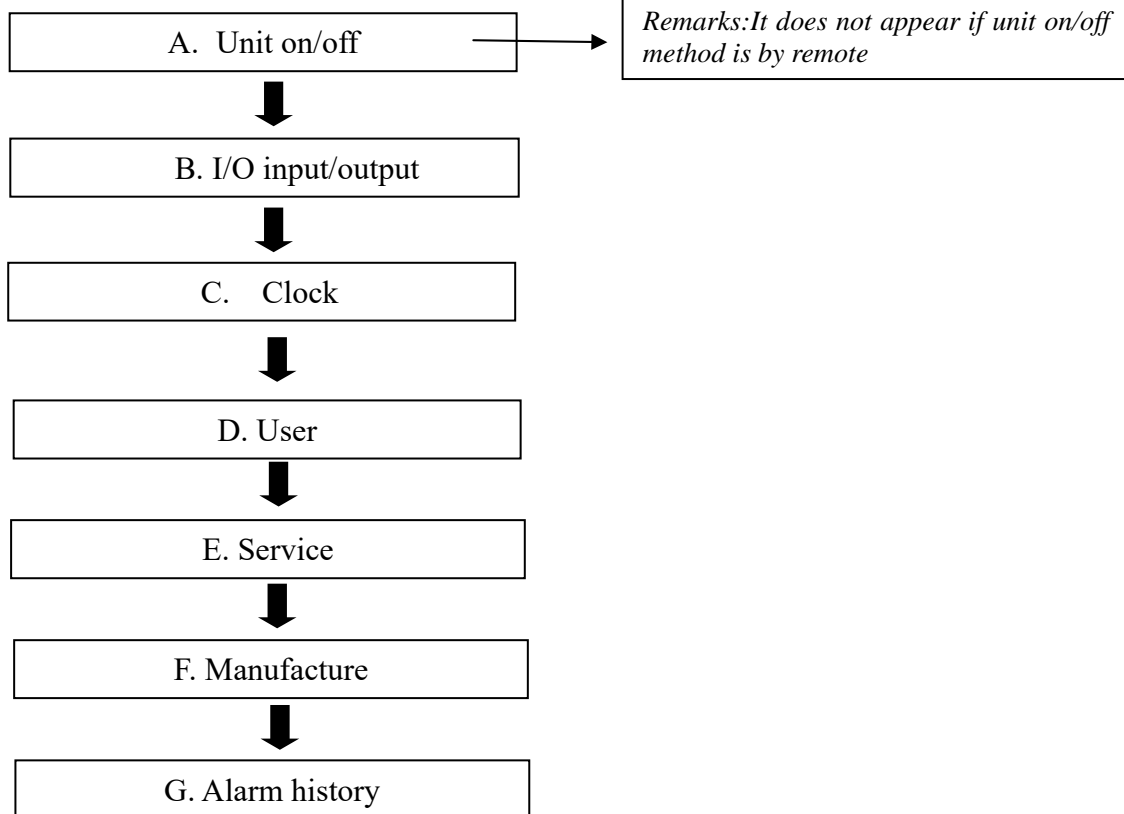

### ◆ Unit on/off (when unit on/off way setting is keyboard)

Press  button, it display

Information	E01
CNHISmVAIE	
Ver. :	1.0.7
	2015/03/10

Press  button, it display the unit current air conditioning (AC) and domestic hot water (HW) On/Off status.

# User Guide

If the pre-set mode is heating, it display AC status(heat).

Unit on/off	
AC status(heat) :	OFF
HW status:	OFF

Black cursor flashes on “OFF” on AC status(heat) , press  button, it display

Unit on/off	
AC status(heat) :	OFF
HW status:	OFF

Press  button to enter. It displays:

Unit on/off	
AC status(heat) :	OFF
HW status:	OFF

Press  button, black cursor flashes on “OFF” on HW status , press  button, it display

Unit on/off	
AC status(heat) :	OFF
HW status:	OFF

press  button to enter, it will display

Unit on/off	
AC status(heat) :	OFF
HW status:	OFF

Unit A/C and DHW are successfully switched on. “Starting “ displays on screen ,water pump turns on and display pump symbol on screen, with some minutes’ delay, fan and compressor will turn on and display the symbol on screen.

Inlet ,outlet, ambient temperature ,etc could be checked via pressing up and down button .

Switching the unit Off is same operation.

The units also could be switched on/off via digital switch A1-A2, B1-B2, referring to chapter Electric connection – A/C switch & hot water switch

# User Guide

## ◆ I/O input/output

This menu display the unit measured temperature sensors value , digital switch on/off state, components on/off state.

B1	RT	AC inlet temp
B2	ST	AC outlet temp.
B3	OT	Ambient temp.
B4	HT	Hot water temp.
B5	PT	Discharge temp.
B6	LPS	Suction pressure
B7	HPS	Discharge pressure
B8	ET	Suction temp.
B9	PWM	Pump duty ratio
DI4		AC switch
DI5		DHW switch
DI6		SG1
DI7		SG2
NO1		DHW circulation pump
NO2		Indoor pump
NO3		4-way valve
NO4		AC heater
NO5		Crankshaft heater
NO6		Inject valve
NO7		3-way valve
N08		DHW heater
N09		De-icing. heater
Y1		EC fan
Y3		Indoor pump PWM

## ◆ Change System mode

Button Operation: Prg → User → System mode

System mode only could be changed on heating/cooling unit (SF01 unit type setting cooling + heating).

When unit is off state, press “Prg” to main menu, press up or down button to User, press Enter button to enter , it display

Unit on/off	
AC status (heat) :	OFF
HW status:	OFF

Press Enter button, Heating will flash, press up or down button to change to Cooling, Press Enter button to confirm.

It will display:

Unit on/off	
AC status (heat) :	OFF
HW status:	OFF

# User Guide

## ◆ Changing Set points (for user)

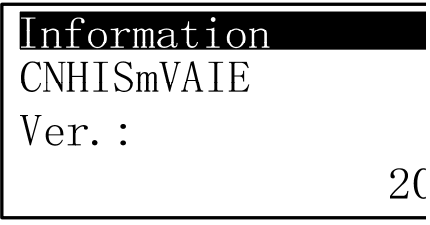
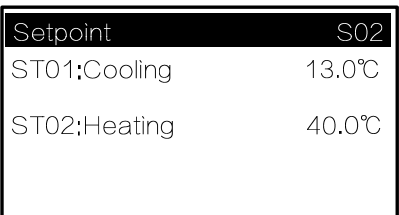
Display	Procedures
	press <Prg> to main menu, press Down button to User, Press Enter button, Press Down button to the desired parameter.
	Press Enter button, when cursor is flashing by 13.0°C, press Up or Down button to change the value. Press Enter to confirm. Cursor will move to next parameter data 40.0°C , 40.0°C could be changed via up or down button. Press Enter to confirm, Cursor will move to set point S02, When cursor is flashing by set point S02, press Down button to next parameters.
Or, continuously press <Esc> to exit out of the current level and back to the desired menu level.	

## User Parameter Table

Parameter	Descriptions	De-fault	Min.	Max.	Unit	Res
mode	Cooling or heating					
ST01	Setting temperature on Cooling mode	13	ST11	ST12	°C	0.1
ST02	Setting temperature on heating mode	35	ST13	ST14	°C	0.1
ST03	Setting temperature difference on Cooling mode	2	1	10	°C	0.1
ST04	Setting temperature difference on Heating mode	2	1	10	°C	0.1
ST06	Compensation factor for heating curve	0.6	0	3	-	0.1
ST07	Ambient temperature condition for starting the boiler or Auxiliary backup electric heater	7	-10	20	°C	0.1
ST08	Compensation factor for cooling curve	0.6	0	3	-	0.1
ST09	Setting temperature on domestic hot water mode	50	ST15	ST16	°C	0.1
ST10	Setting temperature difference on domestic hot water mode	3	1	10	°C	0.1
ST17	SG function :Cooling/heating water temperature decrement/ increment	2	1	10	°C	0.1
ST18	SG function: DHW water temperature increment	5	1	10	°C	0.1
ST33	DHW circulation pump off interval	15	0	180	min	1
ST34	DHW circulation pump running time	3	0	180	min	1
TR09	AC timezone On/Off	disable	Disable or enable			
TR10	HW timezone On/Off	disable	Disable or enable			
SF04	Weather compensation function	No	Yes or No			

User parameters could be adjusted when the unit is ON or OFF.

# User Guide

## Heating compensation curve setting

The control temperature for heating mode has two methods: fixed and changeable temperature. The fixed temperature is a fixed value and directly set by the user from the set area. The changeable temperature is determined by values of ST02, ST06 and the actual outdoor temperature measured by the OT sensor probe.

This function is selected by SF04:

when SF04:ENABLE COMPENSATION=NO, it is fixed temperature;

when SF04:ENABLE COMPENSATION=YES, it is changeable temperature.

Set temperature at heating =  $ST02 + ST06 * (20 - OT)$ .

- ST02 is indoor temperature that the user feel comfortable
- ST06 is the heating compensation coefficient curve factor you select for the heat pump to work with. Increasing ST06 will increase compensation temperature and RT will increase relatively.
- OT is the outside temperature.

The calculated temperature can be used for the control reference, but the maximum data will not exceed ST14

For example:

Set the heating compensation coefficient  $ST06 = 0.5$ ,  $ST02 = 20$

1.) When outdoor temperature is  $0^{\circ}\text{C}$ , the control temperature is  $ST02 + ST06 * (20 - OT) = 20 + 0.5 * (20 - 0) = 30^{\circ}\text{C}$ ;

2.) When outdoor temperature is  $-10^{\circ}\text{C}$ , the control temperature is  $ST02 + ST06 * (20 - OT) = 20 + 0.5 * (20 - (-10)) = 35^{\circ}\text{C}$ ;

3.) When outdoor temperature is  $-20^{\circ}\text{C}$ , the control temperature is  $ST02 + ST06 * (20 - OT) = 20 + 0.5 * (20 - (-20)) = 40^{\circ}\text{C}$ ;

Calculated result as above could be checked from curve below.

## Heating curve $ST02 = 20^{\circ}\text{C}$

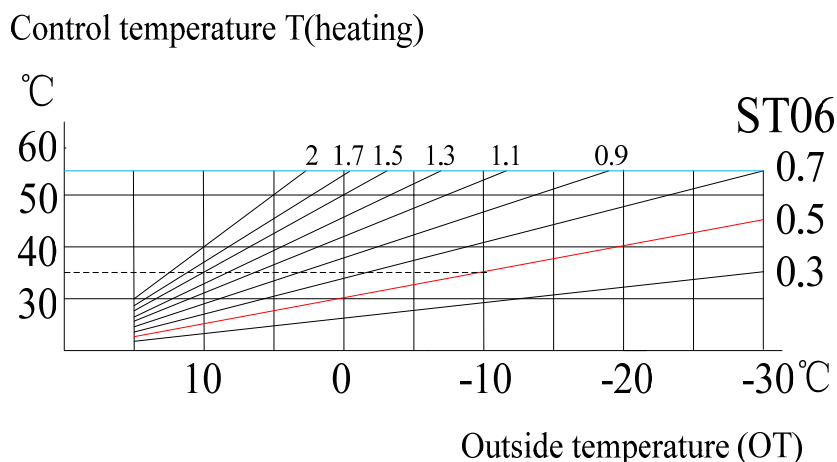

With the drop of the outdoor temperature, the control temperature become higher and higher to meet the large heating requirement.

With the increase of the outdoor temperature, the control temperature become lower and lower, so that the heat pump works under low pressure to keep low energy consumption.

# User Guide

Changing ST02 or ST06 could change the heating curve.

## Increase ST02 will lift up the curve

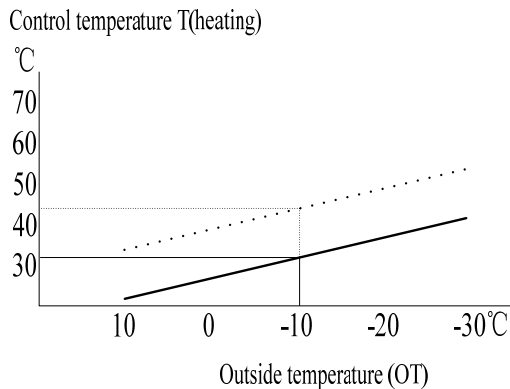

Increase ST06 will increase the grade of the curve

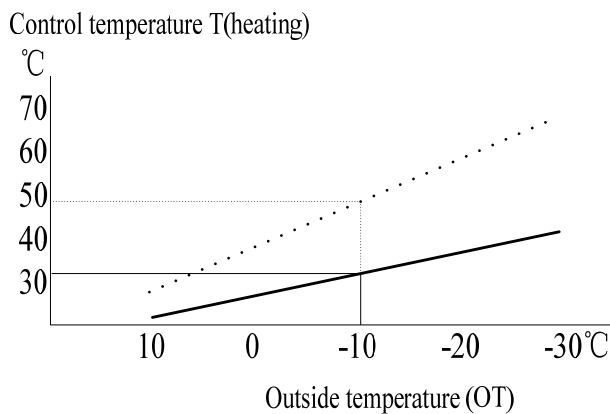

The calculated control water temperature will not be over ST14, will not be lower than ST13.

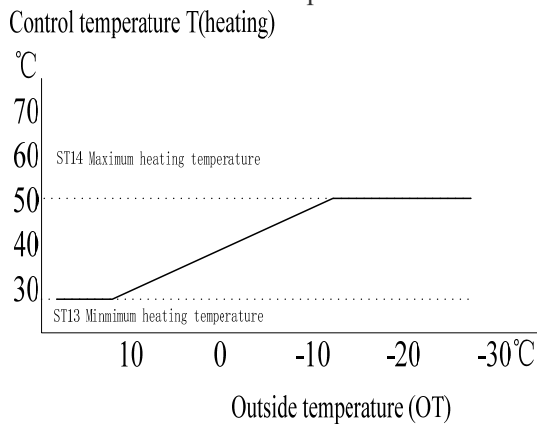

## Cold weather conditions

- When the room temperature is too low, You could increase ST06 .
- When the room temperature is too high, you could decrease ST06.

## Warm weather conditions

- If the room temperature is too low, You could increase ST02 .
- If the room temperature is too high, you could decrease ST02.

The temp. of the room with floor heating need a long time to stabilize .After a ST02 ST06 adjustment, Pls wait 24 hours before you take another adjustment again.



# User Guide

## ◆ Heating curve setup

Heat compensate S16	
ST06	0.6
OT:	-5.0°C
Actual setp:	44.0°C

Press  to change ST06, OT is actual measured ambient temp. Actual control temp. RT will be displayed.

Press  to menu :

Heat compensate S17	
OT:	-1.0°C
Heat setp:	47.6°C

You could input any OT value ,press  and relative heating control temp. will be calculated.  
If OT=-1.0°C, actual control temp. is 47.6°C

If you have your own curve, you want to have RT =40°C (T1) when OT=10°C (OT1) and RT=50°C (T2) when OT=-5°C (OT2)

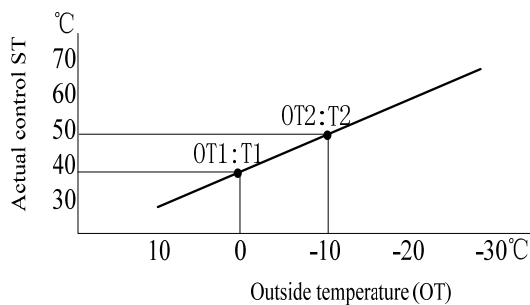

Just adjust wanted T1,T2,OT1 and OT2 in S18 menu and it could help to find out relative ST02 and ST06 setting for desired control inlet water temp in certain OT.

Heat compensate S18	
T1: 40°C	OT1:10.0°C
T2: 50°C	OT2: -5.0°C
ST02=33.3	ST06 = 0.7

As above example, ST02=33.3 ST06=0.7 ,then you could go to relative menu to input checked result into ST02 and ST06 parameter and you will get the desired weather compensation setting .



# User Guide

## Timezone on/off

Unit on/off	
AC status(heat) :	OFF
HW status:	OFF

Timezone activates the pre-set timer programs. Timezone function is only valid when unit Disable/Enable method is “by keyboard”.

TR09:AC timerzone is for space heating

When TR09 is set Enable, two different time periods is available to set in every day from Sunday to Saturday.

Unit on/off	
AC status(heat) :	OFF
HW status:	OFF

After finishing timer setting for Monday , then scroll to “Monday” and press up or down button to change to Tuesday to set its timer , then Wednesday and so on. If ON and OFF data is same, the timer function is not activated.

TR10:HW timezone is for domestic hot water.

When TR10 is set Enable, two different time periods is available to set in every day from Sunday to Saturday

Unit on/off	
AC status(heat) :	OFF
HW status:	OFF

If the unit is manually turned on by keyboard before the automatic turning on by the timer, this timer ON program is implemented and unit will be turned off automatically when the time of timer OFF has come.

If the unit is manually turned off by keyboard before the automatic turning off by the timer, this timer OFF program is implemented .

If everyday timezone setting is same, do not need to set day by day, just go to

Timezone on/off	
Monday:	
Copy from Monday	
Confirm:	NO

Change Monday to Tuesday, and change “No” to “Yes” ,then Tuesday’s timezone setting will be same as Monday.

With the same method to change Wednesday....etc.

# User Guide

## Compressor Operating hours

Display compressor operating hours.

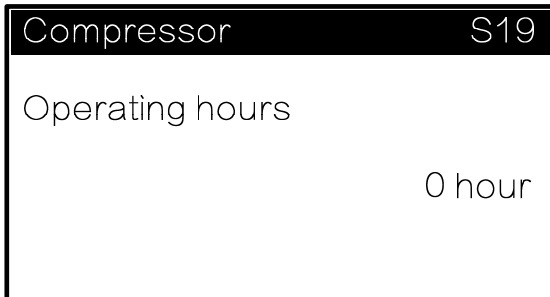

## Insert User default

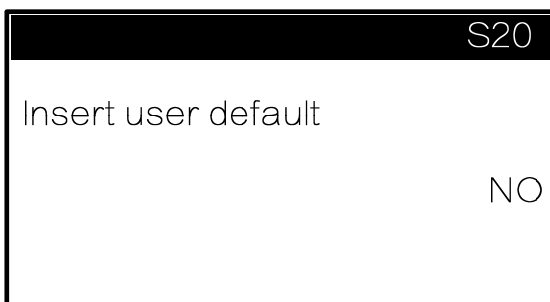

This function is to restore user setting to factory default setting . Change “NO” to “YES”, press <Enter> , it will display “Operation succeed” .

## Important safety information for end users

Installation and service works of the heat pump should only be done by authorized installer and after sales people.

Do not let children to play the heat pump .

Under some conditions, the heat pump will need defrosting. Ice on the evaporator will be melt and a short cloud of condensation from the heat pump will come out. The surface below the heat pump will be wet due to the drained water from evaporator.

Do not attempt to modify, repair or service the appliance yourself.

Do not insert body parts or any other items into the air inlet or air outlet.

Do not start or stop the unit by removing the power cable; always use the controls and switches provided.

Do not operate the unit or controller with wet fingers.

Upon replacement of the fuse, ensure an adequate replacement is used (e.g. not fuse wire).

The electrical supply must be isolated during a heightened risk of lightning strikes.

Do not attempt to move the appliance once installed; this must be carried out by a qualified engineer.

Isolate the electrical supply to the appliance if an odour presents, or scorching is detected.

Only use this appliance for the purpose intended.

Ensure the area around the appliance is clean, well-ventilated and kept free of all obstructions.

Do not keep items on top of the appliance or use it to support other appliances.

Do not under any circumstances stand on the appliance.

Drain the water from the water circuit if power to the unit is to be switched off during very cold weather.

Periodically check the condition of any supports for deterioration.

Do not wash the unit with water, alcohol, benzene, thinners, glass cleaner, polish or powders.

During cleaning, isolate the electrical supply to the appliance.

# Service Guide

## Access Service Level Parameter data

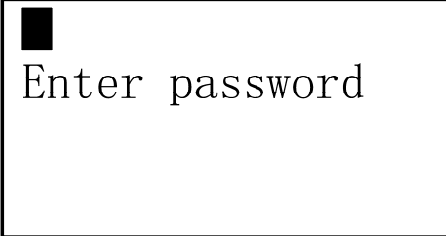
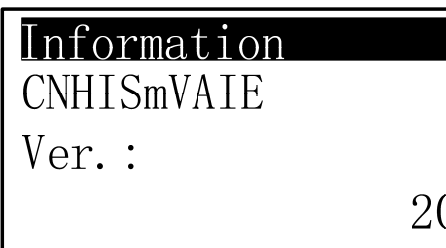
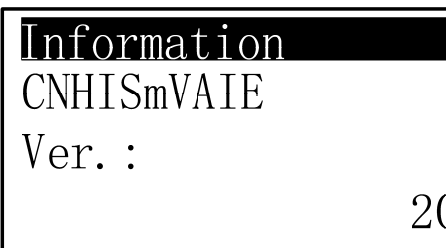
<i>Display</i>	<i>Procedures</i>
 <p>Enter password</p>	<p>press &lt;Prg&gt; to main menu, press Down button to Parameter, Press Enter button, Press Enter and 0 will flash, press Down button to the correct figure, press Enter to confirm. Likewise, change the other 3 figure .After 4 correct figure are inputted, It will enter Service level parameter.</p>
 <p>Information CNHISmVAIE Ver. : 20</p>	<p>Press Enter button, It display controller version information.</p>
 <p>Information CNHISmVAIE Ver. : 20</p>	<p>Press Down button, it goes to Unit type setting. Press Enter to confirm, when Cooling+heating is flashing, press Up or Down button to change the value. Press Enter to confirm. Cursor will move to E02 When E02 is flashing, press Down button to next parameters.</p>
<p>Or, continuously press &lt;Esc&gt; to exit out of the current level and back to the desired menu level.</p>	

# Service Parameters

## Service Parameters:

Parameter	Descriptions	De-fault	Min.	Max.	Unit	Res
information	Software version	A5200				
EV03	Inlet/outlet water temperature difference setting on cooling mode	5	1	10	°C	0.1
EV04	Inlet/outlet water temperature difference setting on heating mode	5	1	10	°C	0.1
SF01	Unit type	Only heating or Cooling + Heating	Only heating or Cooling + Heating			
SF05	Enable domestic hot water function	YES	YES or NO			
SF13	HW On/Off way	Keyboard	Keyboard or remote			
SF14	AC On/Off way	Keyboard	Keyboard or remote			
TR12	SG function	disable	Disable or enable			
DF02	Defrost start LPS	-2	-10	10	°C	0.1
DF03	Defrost start outdoor temperature	12	3.0	20.0	°C	0.1
DF04	Defrost temperature differential (OT-LPS))	18	8	20	°C	0.1
DF05	Continual time when OT-LPS≤DF04	60	1	1000	Sec	1
DF06	Minimum defrost interval	30	15	90	Min	1
DF09	Defrost end HPS temperature	35	5	60	°C	0.1
DF10	Max. defrost time	480	1	1000	Sec	1
DF13	Fan start HPS	20	5	60	°C	0.1
DF15	De icing heater start ambient temperature	0	-10	10	°C	0.1
DF16	Compulsive defrost running interval	120	60	180	Min.	1
AR04	Circulation pump flow detect delay time	30	1	120	s	1
ST26	DHW bacteria killing interval	360	0	1000	h	0.1
UI01	Service password		0000	9999	-	1

Service parameter is code protected and only could be adjusted when unit is OFF.

# Service Guide

## Cooling demand

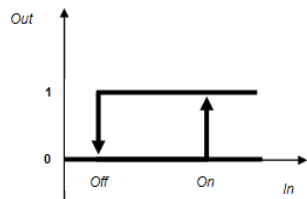

In: RT

On:  $RT > T(\text{cooling}) + ST03$  (  $T(\text{cooling})$  is the control water temperature on cooling mode )

Off:  $RT < T(\text{cooling}) - 1.5^{\circ}\text{C}$  and running frequency of the compressor has reduced to Minimum and lasts for 120s.

### T(cooling) calculation:

Default  $ST01=13, ST08=0.6$

1.) When  $SF04=\text{No}$ , there is no cooling curve.  $T(\text{cooling})=ST01$ .

2.) When  $SF04=\text{Yes}$ , cooling curve is activated ,

$$T(\text{cooling}) = ST01 + (35 - OT) \times ST08$$

If calculated  $T(\text{cooling})$  is lower than  $ST11$  and  $ST11$  would be  $T(\text{cooling})$ .

## Heating demand

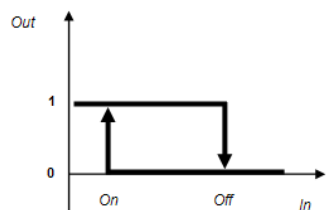

In: RT

On:  $RT < T(\text{heating}) - ST04$  (  $T(\text{heating})$  is the control water temperature on heating mode )

Off:  $RT > T(\text{heating}) + 2^{\circ}\text{C}$  and running frequency of the compressor has reduced to Minimum and lasts for 120s.

### T(heating) calculation:

Default  $ST02=35, ST06=0.6$

1.) When  $SF04=\text{No}$  , there is no heating curve.  $T(\text{heating})=ST02$ .

2.) When  $SF04=\text{Yes}$ , heating curve is activated ,

$$T(\text{heating}) = ST02 + (20 - OT) \times ST06$$

If calculated  $T(\text{heating})$  is higher than  $ST14$  ,  $ST14$  would be  $T(\text{heating})$ .

Refer to chapter "Heating compensation curve setting" .

## Domestic hot water demand

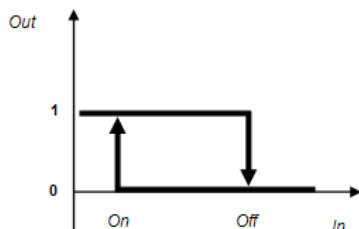

In: HT

1.) When  $ST09 \leq ST20$

Compressor ON:  $HT \leq ST09 - ST10$

Compressor Off:  $HT > ST09$

2.) When  $ST09 > ST20$

Compressor On:  $HT \leq ST20 - ST10$

Compressor Off:  $HT > ST20$

Remarks: when DHW set point  $ST09$  is lower than  $ST20$ , only compressor is switched on to produce DHW.

When DHW set point  $ST09$  is higher than  $ST20$ , DHW will be heated to  $ST20$  by compressor and then electric heater instead of compressor will be switched on to heat DHW to set point.

# Service Guide

## Control process

### Turn on process on heating mode

- 1.) Start water pump , check water flow
- 2.) if water flow meet requirement and there is heating demand, start fan and compressor

### Turn off process on heating mode

- 1.) Switch off compressor
- 2.) After 5 second's delay, switch off fan motor
- 3.) After 30 seconds' delay, switch off water pump .

### Turn on process on cooling mode

- 1.) Start water pump and 4 way valve, check water flow
- 2.) if water flow meet requirement and there is cooling demand, start fan and compressor

### Turn off process on cooling mode

- 1.) Switch off compressor
- 2.) After 5 seconds' delay, switch off fan motor
- 3.) After 30 seconds' delay, switch off water pump .
- 4.) After 120 seconds' delay, switch off 4 way valve.

### Turn on process on hot water mode

- 1.) start 3 way valve and water pump, check water flow .
- 2.) if water flow meets requirement , start fan and compressor

### Turn off process on hot water mode

- 4.) Switch off compressor
- 5.) After 5 seconds' delay, switch off fan motor
- 6.) After 30 seconds' delay, switch off water pump and 3 way valve.

## Hot water priority:

- When unit is heating, if there is a call for hot water , it start 3 way valve at once and turn to hot water mode directly. It will revert back to heating mode after hot water reach set temperature.
- When unit is cooling, if there is a call for hot water , it stops compressor first and then start at hot water mode , it stops compressor again when hot water reach set temperature before it revert back to cooling mode.

## Water pump control

- Circulation pump is switched on when cooling, heating or DHW mode is turned on. Circulation pump continues to run on cooling, heating or DHW mode running .
- On cooling mode and compressor is ON, circulation pump PWM signal output is 100% for the first 3 minutes, and then run PID control to achieve  $(CMF-CM13) / (CM12-CM13) * (EV05-EV06) + EV06 = EV03$ . CMF is current compressor running frequency when cooling set point is met and compressor is OFF, circulation pump continues to run to keep current flow rate.
- On heating mode and compressor is ON, circulation pump PWM signal output is 100% for the first 3 minutes, and then run PID control to achieve  $(CMF-CM16) / (CM15-CM16) * (EV05-EV06) + EV06 = EV04$ . when heating set point is met and compressor is OFF, circulation pump continues to run to keep current flow rate

# Service Guide

During defrosting period and 3 minutes after the end of defrosting , circulation pump PWM signal output is 100%.

After circulation pump stops running over 24 hours ,circulation pump is switched on and runs 3 minutes .The PWM signal output is 60% . This is to prevent the pump from seizing.

If circulation pump is switched on and there is cooling, heating or DHW demand, after AR05 time delay, unit will check water flow rate feedback .If the feedbacked flow rate is smaller than  $EV06 \times 0.8$ , compressor is not allowed to switch ON until flow rate is higher than  $EV06 \times 0.8$  and lasts 5 seconds.

If the feedbacked pump duty ratio is smaller than 5% after the pump is switched on more than AR05 time delay, the pump is diagnosed as idle running. After 10 minutes' continual running, if feedbacked pump duty ratio is still less than 5% ,pump will be switched off. Pump only could be switched on again after the unit is switched off and re-switched on again.

All faults relative to the circulation pump ( feedbacked pump duty ratio is smaller than 8% or higher than 75% ) is activated as AL76 alarm.

Duty ratio feedback (between 0~70%) is linear relation to water flow rate feedback EVQ ,duty ratio= $EVQ/0.057$

## Compressor running control

1.) On cooling mode, when  $RT \leq T(\text{cooling}) - 0.5^\circ\text{C}$  , compressor runs with minimum frequency.  
when  $RT \leq T(\text{cooling}) - 1.5^\circ\text{C}$  , after running 120 seconds with minimum frequency, compressor is switched off.  
when  $ST \leq 7^\circ\text{C}$  , compressor runs with minimum frequency.  
when  $ST \geq 8^\circ\text{C}$  , compressor runs with normal PID control.

2.) On heating mode, when  $RT \geq T(\text{heating}) + 0.5^\circ\text{C}$ , compressor runs with minimum frequency.  
when  $RT \geq T(\text{heating}) + 2^\circ\text{C}$  , after running 120 seconds with minimum frequency, compressor is switched off.

3.) Compressor running frequency is adjusted in every SF19 time.  
The first time compressor is switched on for heating or cooling , it runs 2 minutes with 45Hz and then runs with PID control.  
When compressor is switched on again from a standby state, it runs with minimum frequency 2 minutes and then runs with PID control.

4.) DHW running  
On DHW running ,when  $OT \geq 26^\circ\text{C}$ , compressor runs with fixed frequency (default 50Hz).  
when  $OT < 25^\circ\text{C}$  , compressor runs with default frequency plus 10Hz .

### 5.) oil return running

1.) If accumulated compressor running time is over 120 minutes with the running frequency lower than 40Hz or higher than 60Hz, an oil return running is activated. On the compressor running accumulated counting process, if compressor running frequency is over 40Hz or lower than 60Hz in continual 2 minutes, the accumulated counting data is reset to 0 and accumulated counting starts again.  
2.) Oil return running process : Compressor runs 60 seconds with running frequency 50Hz and then returns to previous running frequency. During this process and within 60 seconds from the end of this process , circulation pump runs with EV05 PWM speed . During this process, if low outlet water temperature protection or high outlet water temperature protection alarm is activated, compressor is switched off but this alarm does not display on user interface.

### 6.) High frequency running limit

After first time switching on, if compressor runs with the maximum running frequency over 30 minutes ,the running frequency will be limited to lower than rated running frequency in next 30 minutes.

Except conditions below, it will not run with frequency higher than rated.

- Re-start after power cut out and cut in again.
- Switch on from off state
- switch on from stop state after a fault

# Service Guide

7.) Reduce running frequency to protect the compressor.

A.) pressure protection

When system pressure is higher than 36Bar in continual 5 seconds, compressor running frequency reduces 10Hz , 10 seconds later:

a.) if system pressure is still higher than 36Bar in continual 5 seconds, compressor running frequency reduces 10Hz more and so on until the system pressure is no longer higher than 36Bar in continual 5 seconds.

b.) if system pressure is lower than 36Bar in continual 5 seconds, it keeps current running frequency. Until system pressure reduces to lower than 34Bar in continual 5 seconds, it will restore to PID control running.

If compressor running frequency reduces to 40Hz and system pressure is not higher than 38Bar, compressor runs with 40Hz . If system pressure still goes up to over alarm setting limit in continual 5 seconds ,compressor is switched off and re-switched on again after 3 minutes' delay.

B.) Discharge gas temperature protection

If Discharge gas temperature  $PT \geq 100^{\circ}\text{C}$  in continual 5 seconds, compressor running frequency reduces 10Hz in every 10 seconds until  $PT \leq 95^{\circ}\text{C}$  in continual 5 seconds, and then compressor running speed will store to PID control.

C.) IPM module temperature protection.

If IPM module temperature  $\geq 80^{\circ}\text{C}$  in continual 5 seconds, compressor running frequency will be reduced 10Hz in every 10 seconds until  $PT \leq 75^{\circ}\text{C}$  in continual 5 seconds, and then compressor running speed will store to PID control.

D.) Compression ratio protection

After compressor has run 10 minutes, if compression ratio  $((\text{HPS}+1\text{Bar})/(\text{LPS}+1\text{Bar}))$  is more than 8 in continual 5 seconds, compressor running frequency reduce 10Hz , 10 seconds later:

1.) if compression ratio is no more than 8 in continual 5 seconds, it keeps current running frequency.

2.) if compression ratio is still more than 8 in continual 5 seconds, compressor running frequency reduces 10Hz more and so on until compression ratio is no more than 8 in continual 5 seconds . then it keep current running frequency .

If compression ratio is less than 7 in continual 5 seconds, it will restore to PID control speed running.

If compressor running frequency reduces to 40Hz and compression ratio is no more than 8 in continual 5 seconds, compressor runs with 40Hz .if compression ratio is still more than 8 in continual 5 seconds, compressor is switched off and re-switched on again after 3 minutes' delay.

## 4 way valve control

4 way valve is OFF under any of below conditions. It is ON under any other conditions.

- 1.) Heating mode, hot water mode, or heating + hot water mode
- 2.) Producing hot water on cooling + hot water mode.



# Service Guide

## Auxiliary Electric backup heater or boiler control

Auxiliary backup heater or boiler only could be switched on when all of conditions below are met.

- 1.) Heating mode running and compressor has been running with the maximum workable frequency.;
- 2.) Compressor has run over 300s
- 3.)  $OT \leq ST07$ ;
- 4.)  $RT \leq T(\text{heating}) - ST04 - 2$ ;

Auxiliary backup heater or boiler is switched off when any of conditions below is met.

- 1.) A/C flow alarm.
- 2.)  $RT \geq T(\text{heating}) - 2$ ;
- 3.) unit is switched off

Auxiliary backup heater or boiler is switched on during defrosting period and is switched off when the any of conditions as above mentioned is met after the end of defrosting.

## Crankcase heater running control

When all of conditions below are met, compressor crankcase heater is switched on

- 1.) Compressor is OFF;
- 2.)  $OT \leq 10^{\circ}\text{C}$

When any of conditions below is met, compressor crankcase heater is switched off

- 1.) Compressor is ON;
- 2.)  $OT \geq 11^{\circ}\text{C}$

## 3 way valve control

3 way valve is ON when there is DHW demand . Otherwise, it is OFF.

## DHW circulation pump control

- 1.) when DHW mode is switched on, DHW circulation pump will be switched on and run ST34 in every ST33 interval.
- 2.) when DHW mode is switched off, DHW circulation pump is switched off after 3 minutes' delay.

## DHW electric heater control

- 1.) If  $ST09 < ST20$ , DHW is only heated by compressor.
- 2.) If  $ST09 > ST20$ , compressor stops heating DHW after  $HT \geq ST20$  ,DHW electric heater is switched on until  $HT \geq ST09$ .
- 3.) If the unit with fault and there is DHW demand, DHW heater is switched on until  $HT \geq ST09$
- 4.) DHW heater is switched on to kill bacteria until  $HT \geq ST27$  if HT is not over ST27 in ST26 time interval. If  $ST26=0$ , bacteria killing function is not valid. by default  $ST26=360$ hours.

# Service Guide

## The EC fan running control

On cooling mode, EC fan motor speed is regulated as the formula:  $CN03 + (OT - CN06) / (CN05 - CN06) * (CN01 - CN03) * (CMF - CM13) / (CM12 - CM13)$ . Remark: CMF is current compressor running frequency

On heating and DHW mode, EC fan motor speed is regulated as the formula:  $CN03 + (CN08 - OT) / (CN08 - CN07) * (CN02 - CN03) * (CMF - CM13) / (CM15 - CM16)$ ;

If feedbacked IPM temperature is over 90°C, EC fan motor runs with CN01 speed.  
After IPM temperature ≤ 85°C, it returns to run as the formula calculation speed.

## The EC fan input control voltage and speed table

Series No.	Input control Voltage	Speed (rpm)
1	2.8V	300
2	2.9V	342
3	3.0V	374
4	3.1V	414
5	3.2V	447
6	3.3V	478
7	3.4V	510
8	3.5V	540
9	3.6V	564
10	3.7V	590
11	3.8V	617
12	3.9V	642
13	4.0V	665
14	4.1V	690
15	4.2V	714
16	4.3V	735
17	4.4V	754
18	4.5V	775
19	4.6V	792

## De-icing heater running control

When all of conditions below are met, de-icing heater is switched on

- 1.) Compressor is ON;
- 2.) Heating or DHW mode running
- 3.) Ambient temperature  $OT \leq DF15$

When any of conditions below is met, de-icing heater is switched off

- 1.) Compressor is OFF;
- 2.) Ambient temperature  $OT > DF15 + 2$ ;

# Service Guide

## The pump PWM running control (Y3)

- 1.) On cooling mode, when compressor is on, pump PWM runs as EV05 for 3 minutes, then runs with (Inlet temperature - Outlet temperature) = EV03 as target via PID control. When compressor is off, pump PWM runs as EV06.
- 2.) On heating mode, when compressor on, pump PWM runs as EV05 for 3 minutes, then runs with (outlet temperature - Inlet temperature) = EV04 as target via PID control; when compressor off, pump PWM runs as EV06.
- 3.) On DHW mode, pump PWM runs as EV05. After DHW temperature reaches preset temperature, if the unit does not need to do cooling or heating, pump PWM is off.
- 4.) Pump PWM runs as EV05 on defrosting.
- 5.) As other situation, when pump is on, PWM is EV06, PWM is off when pump is off.
- 6.) Pump PWM will start running for 3 minutes when pump is off for 24 hours to avoid seizure.

## Defrosting control

The unit is equipped with hot gas defrosting. When the conditions of defrosting are met,

- 1.) Compressor speed begins to go down.
- 2.) After compressor speed reduces to 30Hz and last 60 seconds, 4 way valve is switched on, fan motor is switched off and it begins to count defrosting time. The hot gas flows out to the finned coil heat exchanger.
- 3.) 10 seconds after 4 way valve is switched on, compressor speed increases to rated cooling speed.
- 4.) When  $HPS \geq DF13$ , fan motor is switched on and runs in CN03 speed for 10 seconds to blow down the condensed water.
- 5.) After the conditions of ending defrosting is met, compressor speed reduces and it stops counting defrost time.
- 6.) After compressor reduces to 30Hz and last 10 seconds, 4 way valve is switched off and fan motor is switched on. The hot gas flows into brazed plate heat exchanger and the unit returns to heating mode operation.
- 7.) 60 seconds after 4 way valve is switched off, compressor recovers to run with the speed as PID control.

## Defrosting mode activation conditions one (all must be met)

- a.) The unit running time after previous defrosting  $\geq DF06$
- b.) Temperature differential OT minus LPS  $\geq \Delta T$  and last DF05 time.  
 $\Delta T = DF04 - 4 * (CM15 - CMF) / (CM15 - CM16)$ , CMF is current compressor running frequency
- c.)  $LPS \leq DF02$ .
- d.) Compressor has run more than 5 minutes.
- e.) Ambient temperature OT < DF03

## Defrosting mode activation conditions two (all must be met)

- f.) The accumulated compressor running time is over DF16 after  $LPS \leq DF02$  and compressor has run more than 5 minutes.

When any of above condition one or two are met, unit will start to defrost.

## Defrosting ends condition (any of the following conditions is met)

- A.) High pressure  $HPS \geq AR33$  and last 5 seconds.
- B.)  $HPS \geq DF09$  and last 10 seconds
- C.) AL17 alarm
- D.)  $ST \leq 7^\circ C$  and last 5 seconds.
- E.) Defrost time  $\geq DF10$

## Automatic optimizing defrosting parameter data

Optimization solution one (if the last defrosting is activated by condition one as above)

- 1.) If previous defrosting time is less than 3 minutes and defrosting is terminated by above condition A or B. It means that there is little frost on the evaporator when unit starts defrosting. Then on the next time defrosting, DF04 will add  $1^\circ C$ . After this optimization, next time defrosting will be activated a little later.
- 2.) If previous defrosting time is between 3 to 5 minutes, on next time defrosting, DF04 does not change.
- 3.) If previous defrosting time is over 5 minutes and defrosting is terminated by above condition A or B. If on previous defrosting activation, DF06 is the last condition to meet, then DF04 does not change in next defrosting. Otherwise, DF04 value will reduce  $1^\circ C$  in next defrosting.
- 4.) DF04 optimized value is limited by its max setting and min setting value.

# Service Guide

Optimization solution two ( if the last defrosting is activated by condition two mentioned above)

- 1.) if previous defrosting time is less than 3 minutes and defrosting is terminated by above condition A or B. It means that there is little frost on the evaporator when unit starts defrosting. Then on the next time defrosting, DF16 will add 10 minutes. After this optimization, next time defrosting will be activated a little later.
- 2.) if previous defrosting time is between 3 to 5 minutes, on next time defrosting , DF16 does not change.
- 3.) if previous defrosting time is over 5 minutes and defrosting is terminated by above condition A or B. It means that there are too much frost on the evaporator when the previous defrosting is activated. DF16 value will reduce 10 minutes in next defrosting. After this optimization, next time defrosting will be activated a little earlier.
- 4.) DF16 optimized valued is limited by its max setting and min setting value.

## Temperature sensor offset.

If the temperature sensor readings is with some error. Service parameter come with sensor offset function.

## Insert service default

Service	E16
Insert service default	
	NO

This function is to restore service setting to factory default setting . Change “NO” to “YES”, press <Enter> , it will display “Operation succeed” .

## Alarm initialization

Initialization	
Alarm initialization	
Delete alarm logs?	NO

This function is to delete all alarm logs . Change “NO” to “YES”, press <Enter>.

# Manufacturer parameters

## Access manufacturer Parameter

<i>Display</i>	<i>Procedures</i>
<div style="border: 1px solid black; padding: 5px;"> <div style="background-color: black; width: 15px; height: 15px; margin-bottom: 5px;"></div> <p style="font-family: monospace;">Enter password</p> </div>	<p>press &lt;Prg&gt; to main menu, press Down button to Manufacture, Press Enter button, Press Enter and 0 will flash, press Down button to the correct figure, press Enter to confirm. Likewise, change the other 3 figure .After 4 correct figure are inputted, It will enter Manufacturer.</p>
<div style="border: 1px solid black; padding: 5px;"> <div style="background-color: black; color: white; padding: 2px;"><b>Information</b></div> <p style="font-family: monospace;">CNHISmVAIE Ver. : <span style="float: right;">20</span></p> </div>	<p>Press Down button, it display parameter and data. Press Enter to confirm, when data is flashing, press Up or Down button to change the value. Press Enter to confirm. Cursor will move to P02 When P02 is flashing, press Down button to next parameters.</p>
<p>Or, continuously press &lt;Esc&gt; to exit out of the current level and back to the desired menu level.</p>	

Warning : Manufacturer parameter is related to the unit safe running and reliability. It is not supposed to be changed without manufacturer's permission. Any wrong change could possibly cause the unit broken.

# Manufacturer parameters

Parameter	Descriptions	De-fault	Min.	Max.	Unit	Res
CM02	Compressor minimum OFF time	180	1	1000	Sec.	1
CM11	Rated cooling speed	80	CM13	CM12	HZ	1
CM12	Max cooling speed	90	20	100	HZ	1
CM13	Min cooling speed	20	20	100	HZ	1
CM14	Rated heating speed	80	CM16	CM15	HZ	1
CM15	Max heating speed	90	20	100	HZ	1
CM16	Min heating speed	20	20	100	HZ	1
CM17	DHW running speed	50	40	70	HZ	1
CN01	EC fan Max. speed (cooling)	4	1	10	V	0.1
CN02	EC fan Max. speed (heating)	4	1	10	V	0.1
CN03	EC fan Min. speed	3	1	10	V	0.1
CN05	EC fan Max. speed ambient temp. (cooling)	35	0	50	°C	0.1
CN06	EC fan Min. speed ambient temp. (cooling)	10	0	50	°C	0.1
CN07	EC fan Max. speed ambient temp. (heating and DHW)	7	0	50	°C	0.1
CN08	EC fan Min. speed ambient temp. (heating and DHW)	25	0	50	°C	0.1
EV05	pump PWM Max. speed	100%	0%	100%	0.1%	0.1
EV06	pump PWM Min. speed	60%	0%	100%	0.1%	0.1
EV07	Min. flow feedback	0.5	0	10	m3/h	0.1
EV11	EEV initial opening degree	50	0	100	%	1
EV12	EEV standby position	50	0	100	%	1
SF06	Antifreeze start ambient temp.	2	0	10	°C	0.1
SF08	Antifreeze start outlet water temp.	10	1	20	°C	0.1
SF09	Antifreeze end outlet water temp. difference.	2	1	10	°C	0.1
SF15	PID control factor :KP cooling	1.0	0	50.0	-	0.1
SF16	PID control factor: TI cooling	10	0	100	-	1
SF17	PID control factor: TD cooling	0	0	5	-	1
SF18	PID control: sampling interval, compressor	10	0	100	s	1
SF19	PID: frequency sampling interval ,compressor	10	0	100	s	1
SF20	PID control factor :KP heating	4.0	0	50.0	-	0.1
SF21	PID control factor: TI heating	10	0	100	-	1
SF22	PID control factor: TD heating	0	0	5	-	1
SF25	PID control factor :KP PWM pump	1.0	0	50.0	-	0.1
SF26	PID control factor: TI PWM pump	10	0	100	-	1
SF27	PID control factor: TD PWM pump	0	0	5	-	1
SF28	PID control: sampling interval, PWM pump	10	0	100	s	1
SF29	PID: frequency sampling interval, PWM pump	10	0	100	s	1
SF30	EVI valve open set temp. difference	35	0	99	°C	0.1
SF31	EVI valve off set temp. difference	30	0	99	°C	0.1
SF32	Enable EVI valve		Enable or Disable			
SF34	EEV defrost steps	480	0	480	step	1

AR01	Low outlet water temperature protection	5	1	20	°C	0.1
AR03	High outlet water temperature protection	58	1	100	°C	0.1
AR06	Low pressure alarm times in 24 hours	4	1	10	-	1
AR07	High pressure alarm times in 24 hours	6	1	10	-	1
AR08	low evaporation temperature protection	-2	-10	10	°C	0.1
AR09	Low pressure detect delay time	300	10	1000	Sec.	1
AR13	High Discharge gas temperature protection	115	100	130	°C	0.1
AR14	High Discharge gas temperature protection differential	20	1	30	°C	0.1
AR16	Low evaporation temperature alarm times in 24 hours	2	1	20	-	1
AR29	Antifreeze detect interval	30	1	1000	Min.	1
AR31	Low pressure protection set point	1	0.5	6	bar	0.1
AR32	Low pressure protection differential	1	0.5	6	bar	0.1
AR33	High pressure protection set point	38	30	50	bar	0.1
AR34	High pressure protection differential	3	1	10	bar	0.1
ST11	Minimum settable cooling temperature	12	0	ST12	°C	0.1
ST12	Maximum settable cooling temperature	40	ST11	60	°C	0.1
ST13	Minimum settable heating temperature	20	0	ST14	°C	0.1
ST14	Maximum settable heating temperature	50	ST13	80	°C	0.1
ST15	Minimum settable domestic hot water temperature	20	0	ST16	°C	0.1
ST16	Maximum settable domestic hot water temperature	65	ST15	80	°C	0.1
ST20	Max. DHW temperature made by compressor	50	ST15	ST16	°C	0.1
UI02	Manufacturer password		0000	9999	-	1

Manufacturer parameter is code protected and only could be adjusted when unit OFF.

CN02 Max. EC motor speed should not be over 4.6V in case of overheating.

# Manufacturer parameters

## Reset compressor Operating hours

P34	
Reset comp operating hours	NO

This function is to restore compressor operating time to 0 . Change “NO” to “YES”, press <Enter> .

## Insert manufacturer default

P34	
Insert manuf default	NO

This function is to restore manufacturer setting to factory default setting . Change “NO” to “YES”, press <Enter> , it will display “Operation succeed”

## Initialization

Initialization	
Default installation	
Enable load default value:	NO

Initialization function could restore all user, service and manufacturer parameters to factory default settings. Change “NO” to “YES”, press <Enter>, It display “Loading... ”. The controller then switch on again automatically.



# Commissioning and Adjusting

## Preparations- Filling and Flushing

1. Before commissioning, ensure the whole system has been properly flushed and filled with water.
2. Check the pipe work system for leaks.
3. The heating system is filled with water and inhibitor to the required pressure between 100-200 kPa or 15-30PSI.
4. Vent air out the system using the air venting valves.

## Compressor crankcase heater

- The unit is equipped with a compressor crankcase heater which heats the compressor oil and evaporates the dissolved refrigerant before start-up when outdoor temperature is low.
- The unit must be in the standby state for 6-8 hours before the unit is switched on for the first time. This is so the compressor crankcase heater has the compressor oil at the correct temp before the FIRST start, this will ensure no damage is done to the compressor on start up.

## Start-up and Inspection

1. Turn the isolator switch on.

**Note:**

***Ensure that the heating control system is in the off position first.***

2. The compressor oil heater must have been operational for at least 6–8 hours before a compressor start can be initiated.
3. Start the unit by turning on the heating control system and therefore switching on the unit.
4. The water pump will start , then fan motor, and finally the compressor.

# Commissioning and Adjusting

## **Air in the System after Start-up**

- Air will initially be released from the water as its heated and further venting may be required.
- If a bubbling sound can be heard from the heat pump, the circulation pump, under-floor and or radiators then the entire system will require further venting.
- When the system is stable (correct pressure and all air eliminated) the automatic heating control system can be set as required.

# Commissioning Form



Commissioning Form			
Client / Installation address:		Telephone Number	
Installer:		Commissioned by	
Heat pump Model:		Heat pump serial number:	
Commissioning date:			
The heating system has been filled and pressure tested			YES ( )
Expansion vessel for heating is sized, fitted & charged in accordance with manufacturer's instructions			YES ( )
The heat pump is fitted on a solid/stable surface capable of taking its weight			YES ( )
The system has been flushed and cleaned in accordance with BS7593 and heat pump manufacturer's instructions			YES ( )
What system cleaner was used?			
What inhibitor was used?			Qty:( ) litres
Are all exposed external pipeworks insulated?			YES ( )
<b>Central heating mode ( 10 minutes after compressor start to run)</b>			
Is buffer tank installed			Capacity:( ) litres
Inlet	( )°C	discharge	( )°C
outlet	( )°C	suction	( )°C
ambient	( )°C	HPS	( )bar
Power voltage	( )V	Current	( )A
LPS	( )bar	Power voltage	( )V
<b>Domestic hot water mode ( 10 minutes after compressor start to run)</b>			
Is a hot water cylinder installed	Capacity:( ) litres Heating coil diameter ( )mm, length ( )m		
Inlet	( )°C	discharge	( )°C
outlet	( )°C	suction	( )°C
ambient	( )°C	HPS	( )bar
hot water	( )°C	Current	( )A
LPS	( )bar	Power voltage	( )V
Additional heat sources connected: Gas Boiler ( ) Oil Boiler ( ) Electric Heater ( ) Solar Thermal ( )			YES ( )
The heating, hot water and ventilation systems complies with the appropriate Building Regulations			YES ( )
All electrical work complies with the appropriate Regulations			YES ( )
The heat pump and associated products have been installed and commissioned as the manufacturer's instructions			YES ( )
The operation of the heat pump and system controls have been demonstrated to the customer			YES ( )
The operation, installation and maintenance manual has been explained and left with the customer			YES ( )
Commissioning Engineer's Signature			
Customer's Signature (To confirm demonstration of equipment and receipt of appliance instructions)			

# Alarms

The alarms are divided into two groups: auto reset alarms and manual reset alarms.

1. Auto reset alarm, the user is not required to acknowledge and reset it.
2. The corresponding device will be automatically restarted once the alarm status disappears.
3. Once a manual reset alarm is detected, the system will be stopped automatically. The user needs to record and contact the supplier on actions what to do.
4. To acknowledge and reset the alarm press the  button.
5. Ensure that the fault has been fixed before the alarm has been reset.

When an alarm is detected:

- The  icon will continuously flash. An alarm code will be displayed on the screen.
- If more than one alarm is detected, the alarm codes will be displayed successively on the LCD screen. These will be seen by using the  or  buttons, or they are manually acknowledged or reset (only for manual reset alarms).

# Alarms

## Auto Reset Alarms

The following are codes for auto reset alarms with their meanings.

Codes	Meaning
AL01	Low pressure
AL02	High pressure
AL03	Low outlet water temperature (ST<AR01)
AL05	High outlet water temperature (ST>AR03)
AL17	Water flow is short
WN01	Antifreeze
AL20	Low evaporation temperature (only cooling mode)
AL21	High discharge gas temperature
Display offline	User interface and main board communication trouble.

## Manual Reset Alarms

The following are codes for manual reset alarms with their meanings.

Codes	Meaning
AL18	Low pressure alarms times within 24 hours is over the limit
AL19	High pressure alarms times within 24 hours is over the limit
AL31	Low evaporation temperature alarm times within 24 hours is over the limit
AL79	Water pump faulted alarm

# Alarms

## Viewing Alarm history

<i>Display</i>	<i>Procedures</i>
Press <Prg> button , then then press down button to Alarm Logs, press <Enter> to confirm.	
<div style="border: 1px solid black; padding: 5px;"> <p><b>Information</b></p> <p>CNHISmVAIE</p> <p>Ver. : <span style="float: right;">20</span></p> </div>	Press <up> or <down> to view other alarms
<div style="border: 1px solid black; padding: 5px;"> <p><b>Information</b></p> <p>CNHISmVAIE</p> <p>Ver. : <span style="float: right;">20</span></p> </div>	If no alarm is generated, the word “No alarm!” will be displayed.

## Acknowledging and Resetting Manual Reset Alarms

Any alarm detected by the system, either an auto reset alarm or a manual reset alarm will be displayed on the LCD. However, only manual reset alarms require user’s acknowledgement and reset.

- To clear the alarm press < > to acknowledge the alarm.

If the alarm status is cleared, the corresponding device icon and alarm icon  that are flashing will accordingly disappear.

# Alarms

## 1.) Low pressure protection (Code: AL01)

After starting the compressor, it check the low pressure after AR09 delay. If  $LPS \leq AR31$  in continual 120 seconds, then compressor is switched off, 5 seconds later, fan motor is switched off, other parts keep their original state. Alarm code AL01 display on the user interface. After  $LPS \geq AR31+AR32$  in continual 10 seconds, the unit returns to normal operation.

## 2.) High pressure protection (Code: AL02)

It does not trigger high pressure protection on defrosting process and within 10 seconds after end of defrosting .

At other time if  $HPS \geq AR33$  in continual 5 seconds , the compressor is switched off ,after 5 seconds' delay, the fan motor is switched off, other parts keep their original state. Alarm code AL02 display on the user interface. After  $HPS \leq AR33-AR34$ , the unit re turns to normal operation.

## 3.) Low pressure protection (serious) (Code: AL18)

In 24 hours' time, if AL01 is triggered over AR06 times, manual reset alarm AL18 is triggered, then compressor is switched off, 5 seconds later, fan motor is switched off, other parts keep their original state. Alarm code AL18 display on the user interface.

## 4.) High pressure protection (serious) (Code: AL19)

In 24 hours time, if AL02 is trigger over AR07 times, manual reset alarm AL19 is triggered, the compressor is switched off, 5 seconds later, fan motor is switched off, other parts keep their original state. Alarm code AL19 displays on the user interface.

## 5.) Water flow protection (Code: AL17)

A.) AR04 time delay after circulation pump is switched on and circulation pump PWM output is 100% in continual 5 seconds, if feedbacked pump flow is lower than  $EV06*0.8$  in continual 5 seconds, AL17 alarm is triggered.

B.) On the running process , when pump PWM output is 100% , if feedbacked pump flow is lower than  $EV06*0.8$  in continual 5 seconds, AL17 alarm is triggered.

the compressor is switched off, 5 seconds later, fan motor is switched off, other parts keep their original state. Alarm code AL17 displays on the user interface. Unit could returns to normal operation if feedbacked pump flow is over EV06 in continual 5 seconds.

## 6.) Indoor circuit anti-freezing protection (code: WN01)

1.) If pump has been switched off over AR29 time and  $OT < SF06$ , pump is switched on and runs with PWM 100%. 180 seconds later, if  $RT > AR01$ , pump is switched off. If  $RT < AR01$ , WN01 warning is triggered and unit is switched on to run on heating mode until  $RT > 20^{\circ}C$  ,then warning is reset.

2.) If RT sensor is faulted, ST is used instead of RT for anti-freezing protection water temperature reference. If ST sensor is faulted too when  $OT < SF06$ , pump runs continually with PWM 100% .

## 7.) High discharge gas temperature protection (code: AL21)

If Discharge gas temperature  $PT > AR13$  in continual 5 seconds, high Discharge gas temperature protection alarm AL21 is triggered,

the compressor is switched off, 5 seconds later, fan motor is switched off, other parts keep their original state. Alarm code AL21 displays on the user interface.

It will recover to normal operation if  $PT < AR13-AR14$  in continual 5 seconds.

## 8.) Low evaporation temperature protection (Code: AL20)

The protection function will be valid on COOLING mode .

AL20 low evaporation temperature protection is triggered when condition below is met:

1.)  $LPS \leq AR08$  in continual 60 seconds;

2.)  $LPS \leq AR08-2$  in continual 40 seconds;

3.)  $LPS \leq AR08-4$  in continual 10 seconds;

the compressor is switched off, 5 seconds later, fan motor is switched off, other parts keep their original state. Alarm code AL20 displays on the user interface.

It will recover to normal operation 5 minutes later.

# Alarms

## 9.) Low evaporation temperature protection (serious) (Code: AL31)

In 24 hours time, if AL20 is trigger over AR16 times, manual reset alarm AL31 is triggered, the compressor is switched off, 5 seconds later, fan motor is switched off, other parts keep their original state. Alarm code AL31 displays on the user interface.

## 10.) Low outlet water temperature protection (Code: AL03)

If  $ST \leq AR01$  and  $LPS < 0^{\circ}C$  in continual 5 seconds, the compressor is switched off ,after 5 seconds' delay, the fan motor is switched off, water pump runs with PWM 100% ,other parts keep their original state. Alarm code AL03 displays on the user interface. It records the instant inlet water temperature RT1 when unit just stops and returns to normal working after inlet water temperature  $RT \geq RT1 + ST03$ .

## 11.) High outlet water temperature protection (Code: AL05)

If  $ST \geq AR03$  in continual 5 seconds, the compressor is switched off ,after 5 seconds delay, the fan motor is switched off, water pump runs with PWM 100% ,other parts keep their original state. Alarm code AL05 display on user interface. It records instant inlet water temperature RT2 when unit just stops and returns to normal working after inlet water temperature  $RT \leq RT2 - ST04$ .

## 12.) Display offline - User interface and main board communication trouble.

After this trouble happen, unit still can work normally but the user interface can not be used to operate the unit.

## 13.) Temperature Sensor fault (B1-B8 fault is auto reset)

If the temperature sensor is below -35C or higher than 120C , sensor fault is triggered.

sensor	code	Unit's action to deal with the fault
B1 (RT)	AL71	ST replaces RT as temperature control reference. control water temperature +5C on heating mode, -5C on cooling mode. If ST sensor faulted too, unit is switched off.
B2 (ST)	AL72	Cooling mode is invalid Heating and DHW mode is valid ,no high outlet water temperature protection and pump PWM = 100%.
B3 (OT)	AL73	T(cooling)=ST01. T(heating)=ST02 Aux. electric backup heater, crankcase heater and anti-freezing function etc works without OT condition limitation.
B4 (HT)	AL74	Hot water mode is invalid. Alarm code does not display if SF05=0.
B5 (PT)	AL75	Switch off the unit
B6 (LPS)	AL37	Switch off the unit
B7 (HPS)	AL38	Switch off the unit
B8 (ET)	AL76	Relative function is canceled.
B9	AL79	Switch off the unit



# Maintenance

To ensure the optimal performance of the unit regular maintenance is essential. Failure to undertake regular maintenance can reduce the unit performance and of the system shorten the life of the unit .

## Exterior Maintenance

1. Make regular checks throughout the year that the inlet grill is not blocked or clogged by leaves, snow or anything else.
2. Ensure during the colder times of the year that there isn't too much frost or ice building up on or around the unit.
3. Periodically inspected for loose, damaged or broken parts. If these faults are found and not eliminated, the unit could cause physical injury and damage to people, goods and property.
4. Regularly carry out leak checks and immediately repair any leak found. If there is a leak in the plate heat exchanger, this part must be replaced.

## Unit Refrigerant Checks

1. Verify the air grills are clear and clean it at least once a year, or more often if the equipment environment is especially demanding, this ensures that the unit's performance can be maintained.
2. Check the operation of the high-pressure and low pressure switches. Replace them if there is a fault.
3. Check the fouling of the filter dryer (by checking the temperature difference in the copper piping). Replace it if necessary.

Full-load operating test verify the following values:

- A. Compressor high-pressure side discharge pressure
- B. Compressor low-pressure side suction pressure
- C. Charge visible in the sight glass
- D. Verify the charge status by checking the colour indicator of the sight glass
- E. If the colour has turned to yellow, if so change the charge and replace the filter dryer after carrying out a leak test of the circuit
- F. Temperature difference between the heat exchanger water inlet and outlet temperature
- G. Actual liquid sub-cooling, overheating at the expansion device on heat pumps verify correct defrost of the air heat exchanger

# Maintenance

If there is not enough refrigerant in the system, this is indicated by gas bubbles in the moisture sight glass .the unit will have poor performance.

If the low refrigerant charge is significant, large bubbles appear in the moisture sight glass and the suction pressure drops, then the compressor suction superheat will also be high.

Find the leak and completely drain the system with a refrigerant recovery unit. Carry out the repair, leak test and then recharge the system.

**Note:**

*After the leak has been repaired, the circuit must be tested, without exceeding the maximum low-side operating pressure shown on the unit name plate.*

*The refrigerant must always be recharged in the liquid state into the liquid line.*

*The refrigerant cylinder must always contain at least 10% of its initial charge.*

*For the refrigerant quantity per unit, refer to the data on the unit name plate.*

## Verify the Alarm Status

1. Check the alarm menu when the unit is in the standby mode to see if any alarms or warning have occurred.

## Electrical Maintenance

1. Check for correct termination tension of the electrical connections, contactors, isolation switch and transformer.
2. Check the condition of the contactors, fuses and capacitors,
3. Check the condition of the electrical cables and their insulation.
4. Carry out an operating test of tray de-icing heater, compressor oil heater, refrigerant valve and expansion device.
5. Check the phase/earth insulation of the compressors, fans and pumps.
6. Check the compressor, fan and pump winding status.

# Maintenance

## Mechanical Maintenance

1. Check the tension of the fan motor, fan wheel, compressor and control box fixing bolts.
2. Check that no water has penetrated into the control box.

## Evaporator Coil

It is recommended that the finned coils are inspected regularly to check the degree of fouling. This depends on the environment where the unit is installed, areas by the sea can cause increase corrosion and an approved sprayed film coating is recommended.

For coil cleaning proceed as follows:

1. Remove fibers and dust collected on the evaporator face with a soft brush (or vacuum cleaner).
2. Clean the coil with the appropriate cleaning agents

## Water Circuit Checks

1. Clean the water filter if fitted.
2. Purge the system to remove any air.
3. Check the status of the thermal piping insulation.
4. Check the water flow by checking the water inlet and outlet temperature difference.
5. Check the concentration of the anti-freeze protection solution (ethylene glycol or polyethylene glycol).
6. Check the status of the heat transfer fluid or the water quality.
7. Check the expansion tank for signs of excessive corrosion or gas pressure loss and replace it, if necessary.
8. Check that the water pressure safety valve is not leaking
9. Check that the air vent valves are not leaking system water

# Dimensions

## AS07V

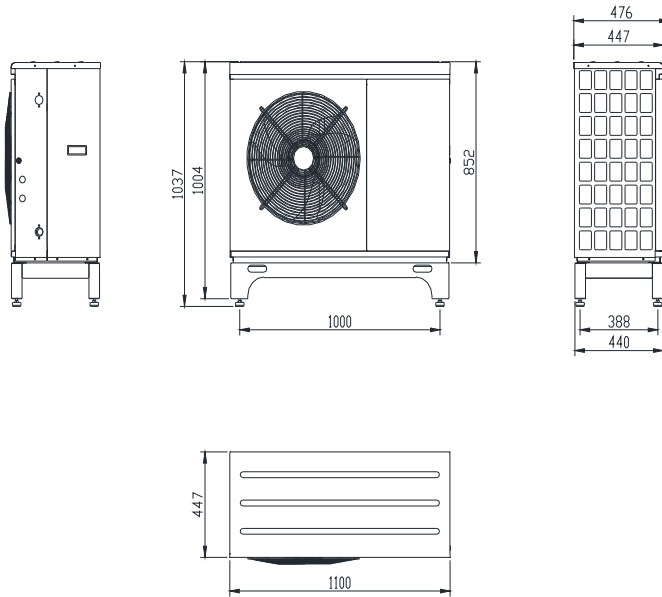

## AS10V

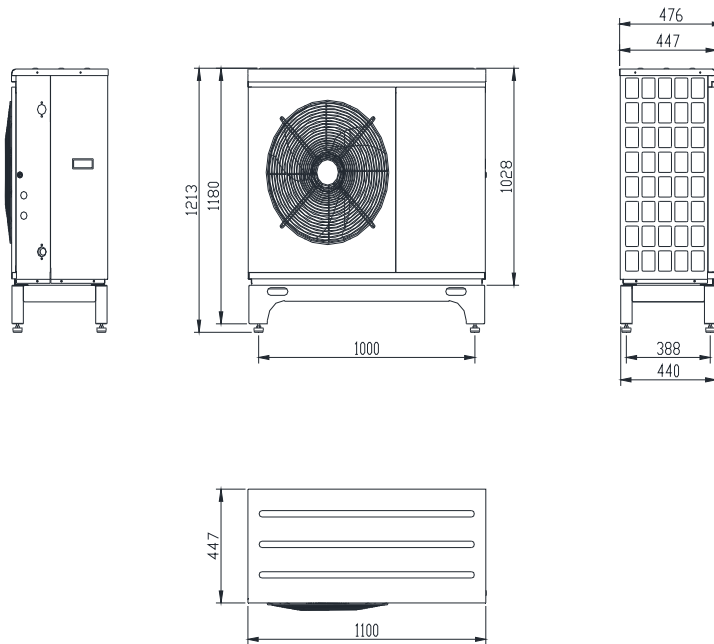

# Water Pressure Plots

AS07V

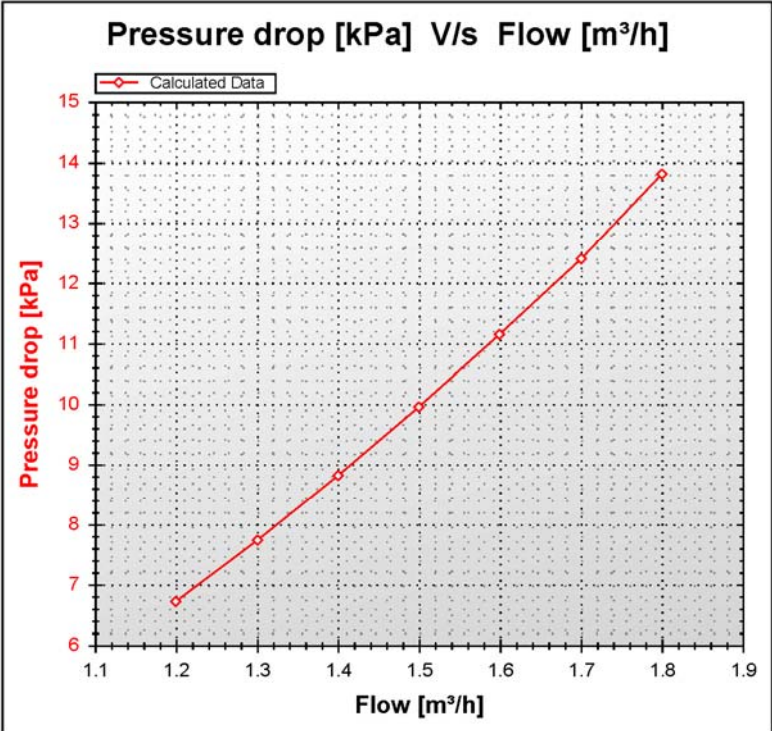

AS10V

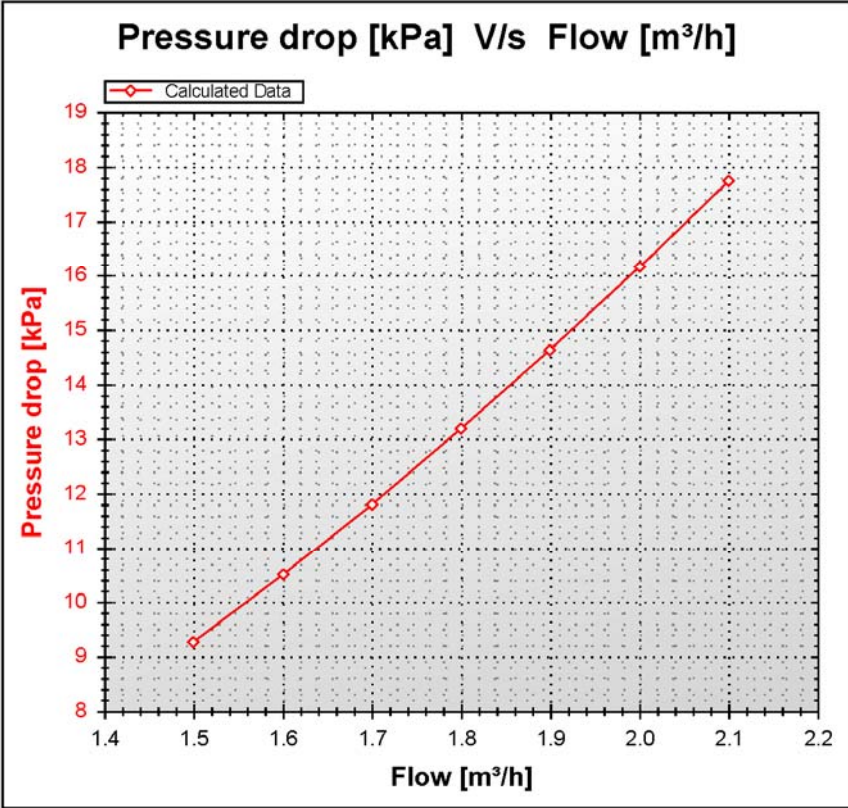

# Pump Curve

Optional high efficiency pump curve  
Model: UPM3K FLEX AS 25-75 130 AZA

Title Test data UPM3 PWM 70m 130  
Product no

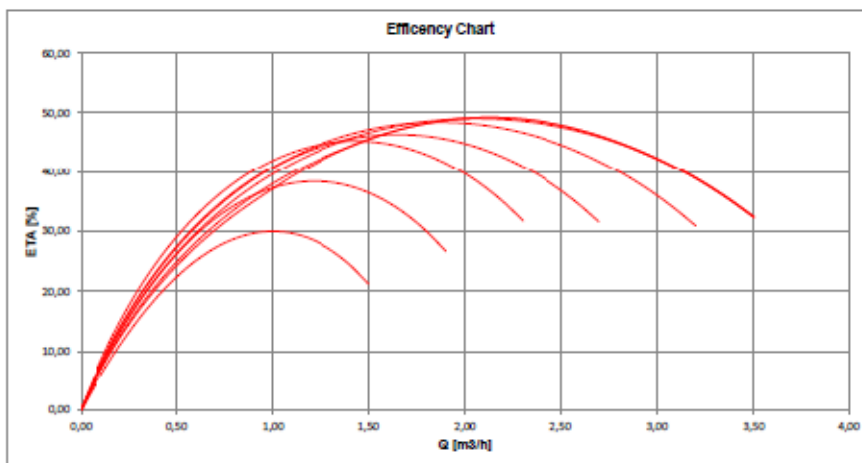
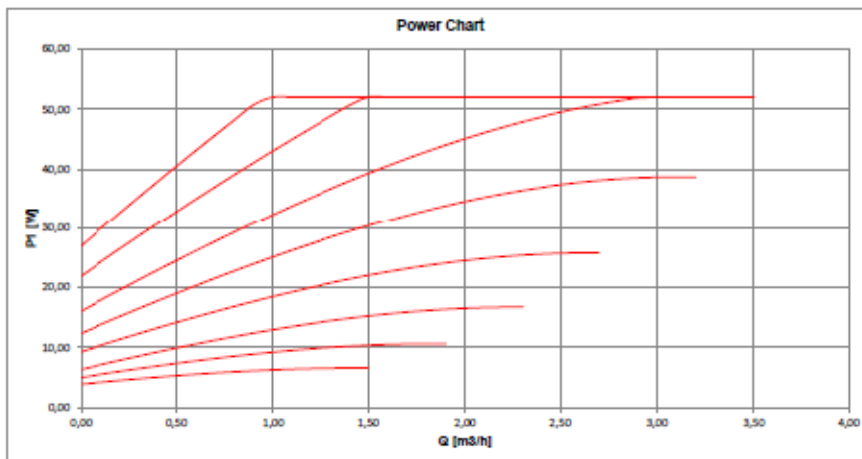
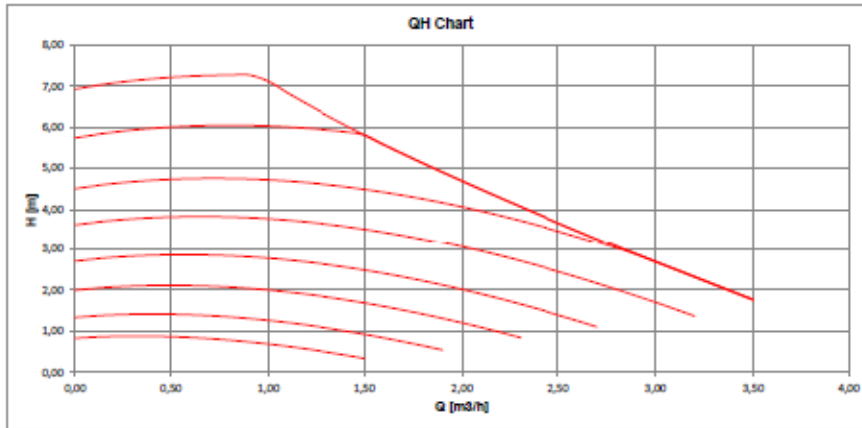

# Temperature and sensor resistance table

Except B5 PT sensor, the other sensors are NTC10K.

R25 : 10.0 k $\Omega$ ±1% B25/50: 3470K±1%

T (°C)	Rmin [ K $\Omega$ ]	Rnom [ K $\Omega$ ]	Rmax [ K $\Omega$ ]
-30	123.5	128.0	132.5
-29	117.0	121.1	125.3
-28	110.8	114.6	118.6
-27	105.0	108.6	112.2
-26	99.48	102.8	106.3
-25	94.33	97.47	100.7
-24	89.49	92.42	95.44
-23	84.92	87.66	90.47
-22	80.62	83.17	85.80
-21	76.56	78.95	81.39
-20	72.74	74.96	77.25
-19	69.12	71.20	73.33
-18	65.71	67.66	69.65
-17	62.50	64.31	66.17
-16	59.54	61.15	62.88
-15	56.58	58.16	59.78
-14	53.86	55.34	56.85
-13	51.29	52.67	54.09
-12	48.86	50.15	51.47
-11	46.56	47.77	49.00
-10	44.38	45.51	46.66
-9	42.32	43.37	44.45
-8	40.36	41.35	42.36
-7	38.51	39.43	40.37
-6	36.75	37.62	38.49
-5	35.09	35.89	36.72
-4	33.51	34.26	35.03
-3	32.01	32.71	33.43
-2	30.59	31.24	31.91
-1	29.23	29.85	30.48
0	27.95	28.53	29.11
1	26.73	27.27	27.81
2	25.57	26.07	26.58
3	24.47	24.94	25.41
4	23.42	23.86	24.30
5	22.42	22.83	23.25
6	21.47	21.86	22.24
7	20.57	20.93	21.29
8	19.71	20.04	20.38
9	18.89	19.20	19.52
10	18.11	18.40	18.69
11	17.37	17.64	17.91
12	16.66	16.91	17.16
13	15.98	16.22	16.45
14	15.34	15.56	15.78
15	14.72	14.93	15.13
16	14.13	14.32	14.51

17	13.57	13.75	13.93
18	13.04	13.20	13.37
19	12.53	12.68	12.83
20	12.04	12.18	12.32
21	11.57	11.70	11.84
22	11.13	11.25	11.37
23	10.70	10.81	10.93
24	10.29	10.40	10.50
25	9.900	10.00	10.10
26	9.522	9.621	9.721
27	9.160	9.259	9.359
28	8.814	8.931	9.012
29	8.483	8.581	8.680
30	8.166	8.264	8.362
31	7.863	7.960	8.058
32	7.573	7.669	7.766
33	7.295	7.391	7.487
34	7.029	7.123	7.219
35	6.774	6.868	6.962
36	6.529	6.622	6.716
37	6.295	6.387	6.479
38	6.071	6.161	6.253
39	5.855	5.945	6.035
40	5.649	5.737	5.826
41	5.451	5.538	5.626
42	5.260	5.347	5.433
43	5.078	5.163	5.249
44	4.903	4.987	5.071
45	4.735	4.817	4.900
46	4.573	4.654	4.736
47	4.418	4.498	4.579
48	4.269	4.348	4.427
49	4.126	4.203	4.282
50	3.988	4.064	4.141
51	3.855	3.930	4.007
52	3.728	3.802	3.877
53	3.606	3.678	3.752
54	3.488	3.559	3.632
55	3.374	3.445	3.516
56	3.265	3.334	3.404
57	3.160	3.228	3.297
58	3.059	3.126	3.194
59	2.962	3.027	3.094
60	2.868	2.933	2.998
61	2.778	2.841	2.905
62	2.691	2.753	2.816
63	2.607	2.668	2.730
64	2.526	2.586	2.647
65	2.448	2.507	2.567
66	2.373	2.431	2.490
67	2.301	2.357	2.415
68	2.231	2.287	2.343



69	2.164	2.218	2.274
70	2.098	2.152	2.207
71	2.036	2.088	2.142
72	1.975	2.027	2.080
73	1.917	1.976	2.019
74	1.860	1.910	1.961
75	1.806	1.855	1.904
76	1.753	1.801	1.851
77	1.702	1.749	1.797
78	1.653	1.699	1.746
79	1.606	1.651	1.697
80	1.560	1.604	1.650
81	1.515	1.599	1.603
82	1.472	1.515	1.559
83	1.431	1.473	1.516
84	1.391	1.432	1.474
85	1.352	1.392	1.434
86	1.315	1.354	1.395
87	1.278	1.317	1.357
88	1.243	1.282	1.321
89	1.209	1.247	1.285
90	1.177	1.213	1.251
91	1.145	1.181	1.218
92	1.114	1.150	1.186
93	1.084	1.119	1.155
94	1.055	1.089	1.125
95	1.027	1.061	1.095
96	1.000	1.033	1.067
97	0.974	1.006	1.039
98	0.948	0.9801	1.013
99	0.9234	0.9548	0.9873
100	0.8994	0.9303	0.9621
101	0.8762	0.9065	0.9378
102	0.8537	0.8834	0.9141
103	0.8318	0.8611	0.8912
104	0.8106	0.8393	0.8689
105	0.7901	0.8182	0.8473
106	0.7270	0.7806	0.8378
107	0.7085	0.7611	0.8173
108	0.6906	0.7422	0.7974
109	0.6732	0.7239	0.7781
110	0.6563	0.7061	0.7594
111	0.6399	0.6888	0.7411
112	0.6240	0.6720	0.7235
113	0.6086	0.6557	0.7063
114	0.5936	0.6399	0.6896
115	0.5791	0.6246	0.6733
116	0.5650	0.6096	0.6576
117	0.5513	0.5951	0.6422
118	0.5380	0.5810	0.6273
119	0.5250	0.5674	0.6128
120	0.5125	0.5541	0.5988

# Temperature and sensor resistance table

Only for PT sensor

R25=50K  $\Omega$   $\pm$ 2% B25/50=3950K  $\pm$ 2%

T (°C)	Rmin [ K $\Omega$ ]	Rnom [ K $\Omega$ ]	Rmax [ K $\Omega$ ]
-20	441.8	471.5	503.0
-19	417.9	445.5	474.7
-18	395.5	421.1	448.2
-17	374.4	398.2	423.4
-16	354.5	376.7	400.0
-15	335.8	356.4	378.1
-14	318.2	337.4	357.5
-13	301.6	319.4	338.1
-12	286.0	302.6	319.9
-11	271.3	286.7	302.8
-10	257.4	271.7	286.7
-9	244.3	257.6	271.5
-8	232.0	244.3	257.3
-7	220.3	231.8	243.8
-6	209.3	220.0	231.1
-5	198.9	208.8	219.2
-4	189.1	198.3	207.9
-3	179.8	188.4	197.3
-2	171.0	179.0	187.3
-1	162.7	170.1	177.8
0	154.8	161.7	168.9
1	147.4	153.8	160.5
2	140.4	146.3	152.5
3	133.7	139.2	145.0
4	127.4	132.5	137.8
5	121.4	126.2	131.1
6	115.7	120.2	124.8
7	110.4	114.5	118.7
8	105.3	109.1	113.0
9	100.4	104.0	107.6
10	95.84	99.14	102.5
11	91.49	94.55	97.68
12	87.35	90.20	93.09
13	83.43	86.06	88.74
14	79.70	82.14	84.62
15	76.16	78.42	80.71
16	72.80	74.88	77.00
17	69.60	71.53	73.48
18	66.55	68.34	70.14
19	63.66	65.31	66.97
20	60.91	62.42	63.96
21	58.28	59.69	61.09
22	55.79	57.08	58.38
23	53.42	54.60	55.79
24	51.15	52.24	53.34

T (°C)	Rmin [ K Ω ]	Rnom [ K Ω ]	Rmax [ K Ω ]
25	49.00	50.00	51.00
26	46.87	47.86	48.86
27	44.83	45.83	46.83
28	42.90	43.89	44.89
29	41.06	42.05	43.04
30	39.31	40.29	41.27
31	37.64	38.61	39.59
32	36.05	37.01	37.98
33	34.54	35.49	36.45
34	33.10	34.03	34.98
35	31.72	32.65	33.58
36	30.41	31.32	32.25
37	29.16	30.06	30.97
38	27.97	28.85	29.75
39	26.83	27.70	28.59
40	25.74	26.60	27.48
41	24.70	25.55	26.41
42	23.71	24.54	25.39
43	22.77	23.58	24.42
44	21.86	22.67	23.49
45	21.00	21.79	22.60
46	20.18	20.95	21.74
47	19.39	20.15	20.93
48	18.64	19.38	20.15
49	17.91	18.64	19.40
50	17.23	17.94	18.68
51	16.57	17.27	17.99
52	15.94	16.62	17.33
53	15.33	16.00	16.70
54	14.75	15.41	16.10
55	14.20	14.85	15.51
56	13.67	14.30	14.96
57	13.16	13.78	14.42
58	12.68	13.28	13.91
59	12.21	12.80	13.42
60	11.76	12.34	12.95
61	11.34	11.90	12.49
62	10.92	11.48	12.06
63	10.53	11.07	11.64
64	10.15	10.69	11.24
65	9.791	10.31	10.86
66	9.444	9.953	10.48
67	9.110	9.608	10.13
68	8.790	9.277	9.786
69	8.483	8.959	9.457
70	8.187	8.653	9.141
71	7.904	8.359	8.837
72	7.632	8.077	8.544
73	7.370	7.805	8.262

T (°C)	Rmin [ KΩ ]	Rnom [ KΩ ]	Rmax [ KΩ ]
74	7.119	7.544	7.991
75	6.877	7.293	7.731
76	6.645	7.051	7.480
77	6.421	6.819	7.238
78	6.207	6.595	7.005
79	6.000	6.380	6.781
80	5.801	6.173	6.565
81	5.610	5.973	6.357
82	5.426	5.781	6.157
83	5.249	5.596	5.963
84	5.078	5.418	5.777
85	4.914	5.246	5.598
86	4.756	5.080	5.424
87	4.604	4.921	5.258
88	4.457	4.767	5.096
89	4.316	4.619	4.941
90	4.180	4.476	4.791
91	4.048	4.338	4.647
92	3.922	4.205	4.507
93	3.800	4.077	4.372
94	3.682	3.953	4.242
95	3.569	3.833	4.116
96	3.459	3.718	3.995
97	3.354	3.607	3.877
98	3.252	3.499	3.764
99	3.153	3.395	3.655
100	3.058	3.295	3.549
101	2.967	3.198	3.447
102	2.878	3.105	3.348
103	2.792	3.014	3.252
104	2.710	2.927	3.160
105	2.630	2.842	3.070
106	2.553	2.760	2.984
107	2.478	2.681	2.900
108	2.406	2.605	2.819
109	2.337	2.531	2.740
110	2.269	2.460	2.665
111	2.204	2.390	2.591
112	2.141	2.323	2.520
113	2.080	2.259	2.451
114	2.022	2.196	2.384
115	1.964	2.135	2.320
116	1.909	2.076	2.257
117	1.856	2.019	2.196
118	1.804	1.964	2.137
119	1.754	1.911	2.080
120	1.705	1.859	2.025

# Components

## AS07V AS10V

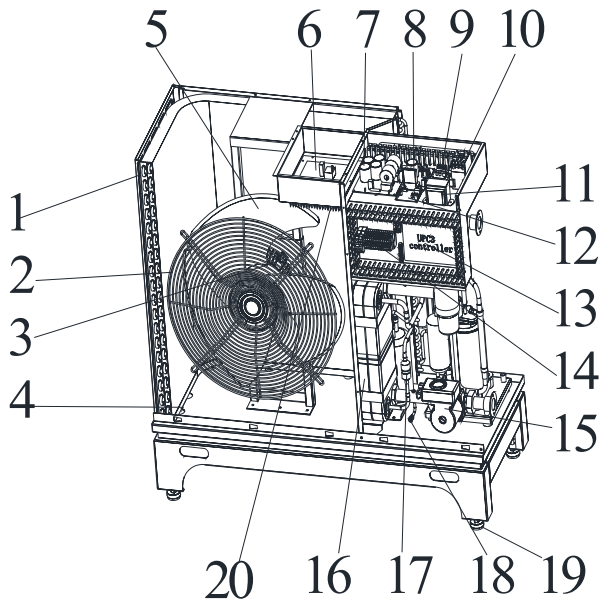

1. Finned coil heat exchanger
2. Grill
3. EC Fan motor
4. De-icing heater
5. Fan blade
6. Inverter board
7. EMC filter
8. EC fan motor board
9. Circulation pump flow feedback
10. A/C contactor
11. Transformer
12. Modbus communication adaption board
13. Controller
14. Terminal block
15. Circulation pump
16. Plate heat exchanger
17. Drying filter
18. Drain valve
19. Adjustable feet
20. Inverter board cooling radiator
21. Aux. backup electric heater
22. 4 way valve
23. HP transducer
24. HP service connection
25. Compressor
26. Crankcase heater
27. Harmonic filter
28. LP transducer
29. EEV
30. LP service connection
31. Accumulator

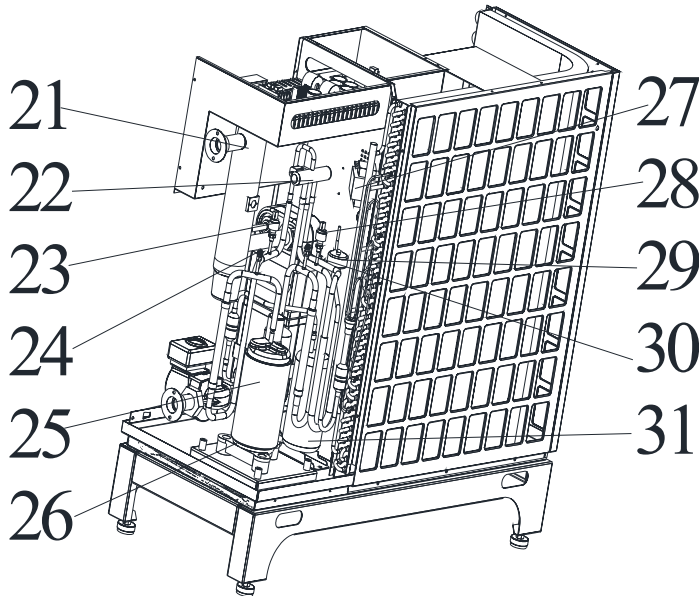

# Technical Specifications

AS07V

Model Number		AS07V		
Heating performance		Min.	Nominal	Max.
Heat output/Power consumption/COP at A7/W35°C	kW	1.92/0.43/4.46	6.69/1.47/4.67	8.64/2.02/4.18
Heat output/Power consumption/COP at A2/W35°C	kW	1.39/0.44/3.13	5.54/1.62/3.42	6.32/1.92/3.30
Heat output/Power consumption/COP at A-7/W35°C	kW	3.08/1.16/2.65	4.40/1.39/3.09	5.61/1.83/2.98
Heat output/Power consumption/COP at A-10/W35°C	kW	2.76/1.12/2.46	3.92/1.37/2.86	5.10/1.79/2.85
Heat output/Power consumption/COP at A-15/W35°C	kW	2.33/1.08/2.16	3.02/1.34/2.25	4.42/1.71/2.51
Heat output/Power consumption/COP at A7/W45°C	kW	1.72/0.57/3.02	6.34/1.80/3.52	8.24/2.43/3.39
Heat output/Power consumption/COP at A2/W45°C	kW	1.24/0.53/2.33	5.15/1.92/2.68	5.76/2.20/2.61
Heat output/Power consumption/COP at A-7/W45°C	kW	2.97/1.52/1.95	4.12/1.65/2.50	5.28/2.14/2.39
Heat output/Power consumption/COP at A-10/W45°C	kW	2.64/1.42/1.86	3.87/1.60/2.42	4.96/2.11/2.35
Heat output/Power consumption/COP at A-15/W45°C	kW	2.20/1.11/1.98	2.82/1.36/2.07	4.15/2.15/1.93
Heat output/Power consumption/COP at A7/W55°C	kW	1.58/0.68/2.32	6.19/2.14/2.85	7.84/2.83/2.73
Cool output/Power consumption/EER at A35/W7°C	kW	1.67/0.63/2.65	5.2/1.84/2.82	6.1/2.23/2.73
Nominal running current at A7/W35	A	6.2		
Max operating current	A	16		
Power Supply		230V/50Hz		
Compressor		Mitsubishi Electric twin rotary		
Condenser		Braze plate heat exchanger		
Nominal flow heating medium	m <sup>3</sup> /h	1.20		
Internal pressure drop at nominal flow	kPa	11		
Nominal air flow	m <sup>3</sup> /h	2000		
Nominal fan output	W	75		
Max outlet heating medium temperature	°C	55		
Refrigerant R410A filling weight	kg	2.2		
Dimensions (HxWxD)	mm	1037X1100X476		
Pipe connector		G1'		
Net Weight	kg	103		
Operating ambient temp. range	°C	Heating -20~35		
		DHW -20~43		
		Cooling 10~45		
Sound power level L <sub>WA</sub>	dB(A)	57		

The above data is tested by EN14511. A7/W35°C means air temp. 7°C, outlet water temp. 35°C

The Sound power level is tested by EN12102

# Technical Specifications

AS10V

Model Number		AS10V		
Heating performance		Min.	Nominal	Max.
Heat output/Power consumption/COP at A7/W35°C	kW	2.72/0.61/4.42	9.90/2.17/4.56	12.38/2.94/4.21
Heat output/Power consumption/COP at A2/W35°C	kW	2.29/0.76/3.01	8.38/2.36/3.54	10.21/3.02/3.38
Heat output/Power consumption/COP at A-7/W35°C	kW	2.53/1.20/2.25	6.56/2.25/2.92	8.24/2.82/2.96
Heat output/Power consumption/COP at A-10/W35°C	kW	2.25/1.16/1.94	5.66/2.25/2.51	7.25/2.86/2.53
Heat output/Power consumption/COP at A-15/W35°C	kW	2.38/1.40/1.71	4.47/2.23/2.01	6.33/2.56/2.47
Heat output/Power consumption/COP at A7/W45°C	kW	2.61/0.76/3.43	9.52/2.61/3.64	11.79/3.45/3.41
Heat output/Power consumption/COP at A2/W45°C	kW	2.20/0.79/2.76	8.06/2.68/3.0	9.66/3.40/2.84
Heat output/Power consumption/COP at A-7/W45°C	kW	2.77/1.43/1.93	6.30/2.53/2.51	7.75/3.37/2.30
Heat output/Power consumption/COP at A-10/W45°C	kW	2.47/1.42/1.74	5.42/2.52/2.15	6.90/3.39/2.03
Heat output/Power consumption/COP at A-15/W45°C	kW	2.62/1.68/1.56	4.29/2.31/1.84	6.0/3.34/1.79
Heat output/Power consumption/COP at A7/W55°C	kW	2.52/0.91/2.75	9.16/3.25/2.82	11.20/4.12/2.71
Cool output/Power consumption/EER at A35/W7°C	kW	2.02/0.72/2.80	7.85/2.60/3.02	8.89/3.12/2.85
Nominal running current at A7/W35	A	9.3		
Max operating current	A	19		
Power Supply		230V/50Hz		
Compressor		Mitsubishi Electric twin rotary		
Condenser		Braze plate heat exchanger		
Nominal flow heating medium	m <sup>3</sup> /h	1.72		
Internal pressure drop at nominal flow	kPa	18		
Nominal air flow	m <sup>3</sup> /h	3000		
Nominal fan output	W	110		
Max outlet heating medium temperature	°C	55		
Refrigerant R410A filling weight	kg	3.2		
Dimensions (HxWxD)	mm	1213X1100X476		
Pipe connector		G1'		
Net Weight	kg	109		
Operating ambient temp. range	°C	Heating -20~35		
		DHW -20~43		
		Cooling 10~45		
Sound power level L <sub>WA</sub>	dB(A)	59		

The above data is tested by EN14511. A7/W35°C means air temp. 7°C, outlet water temp. 35°C

The Sound power level is tested by EN12102