

**INVERTER MULTI
AIR CONDITIONER
FLOOR CONSOLE /
UNDER CEILING
DUAL type**

SERVICE MANUAL



Models

Indoor unit	Outdoor unit
ABY14LBAJ	AOY18LMAK2

CONTENTS

SPECIFICATIONS	1
OUTLINE AND DIMENSIONS	2
REFRIGERANT SYSTEM DIAGRAM	4
CIRCUIT DIAGRAM	5
INDOOR PCB CIRCUIT DIAGRAM	7
OUTDOOR PCB CIRCUIT DIAGRAM	8
ERROR CONTENTS.....	9
DISASSEMBLY ILLUSTRATION	10
PARTS LIST	21
STANDARD ACCESSORIES	24

SPECIFICATIONS

TYPE	COOL & HEAT
INDOOR UNIT	ABY14LBAJ
OUTDOOR UNIT	AOY18LMAK2

ELECTRICAL DATA (INDOOR UNIT)

COOLING CAPACITY	(kW)	4.2
HEATING CAPACITY	(kW)	4.9
MOISTURE REMOVAL	(ℓ /hr)	1.5
AIR CIRCULATION-Hi	(m ³ /hr)	640

ELECTRICAL DATA (OUTDOOR UNIT)

POWER SOURCE	(V)	230	
FREQUENCY	(Hz)	50	
COOLING CAPACITY (MAX)	(kW)	5.5 (6.5)	
HEATING CAPACITY (MAX)	(kW)	6.4 (7.1)	
RUNNING CURRENT (MAX)	(A)	COOLING	7.5 (9.7)
		HEATING	8.0 (9.7)
INPUT WATTS (MAX)	(kW)	COOLING	1.73 (2.22)
		HEATING	1.84 (2.22)
E.E.R.	(kW / kW)	COOLING	3.18
		HEATING	3.48

COMPRESSOR

TYPE	Hermetic type, Inverter, 4 poles, Three phase, DC motor, Rotary
DISCRIMINATION	TNB 220 FPCM
REFRIGERANT	R410A (g) 1,900

FAN MOTOR

POWER SOURCE	(V)	230
INDOOR UNIT	DISCRIMINATION	MFA-14JTT
	HI	(r.p.m.) 850
	MED	(r.p.m.) 760
	LO	(r.p.m.) 670
OUTDOOR UNIT	(r.p.m.)	780

DIMENSIONS

INDOOR UNIT	H x W x D (mm)	199 x 990 x 655
OUTDOOR UNIT	H x W x D (mm)	650 x 830 x 320

WEIGHT

INDOOR UNIT	GROSS / NET (kg)	36 / 27
OUTDOOR UNIT	GROSS / NET (kg)	62 / 56

NOISE LEVEL

INDOOR UNIT	HI	(dB)	36
	MED	(dB)	33
	LO	(dB)	29
OUTDOOR UNIT	COOLING	(dB)	49
	HEATING	(dB)	50

OUTLINE AND DIMENSIONS

Unit : mm

INDOOR UNIT

Model : ABY14LBAJ

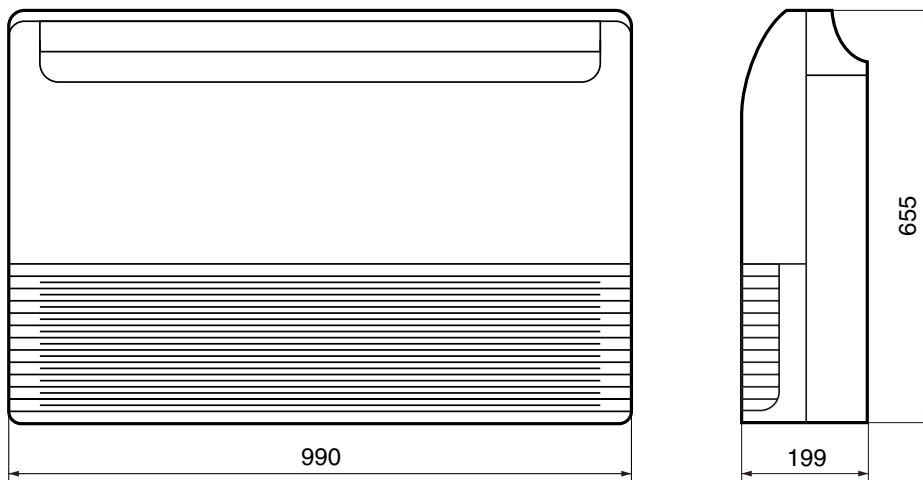

(rear view)

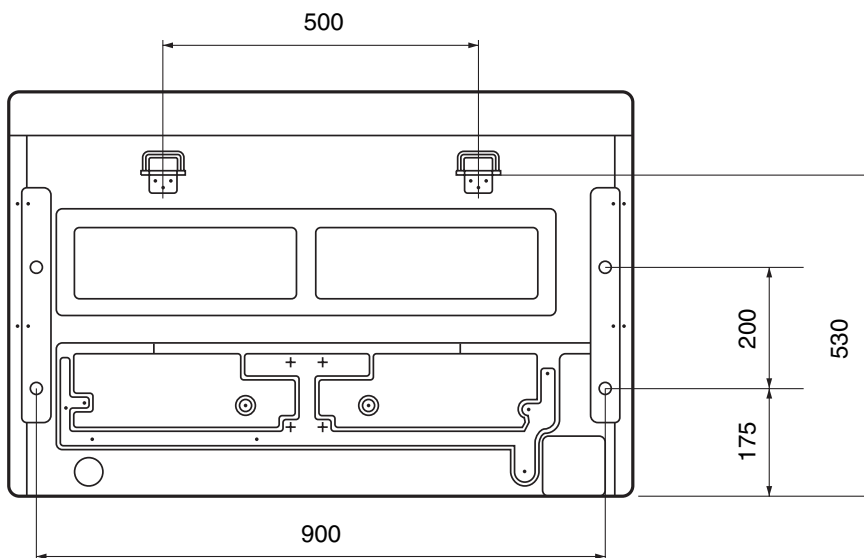

OUTDOOR UNIT

Unit : mm

Model : AOY18LMAK2

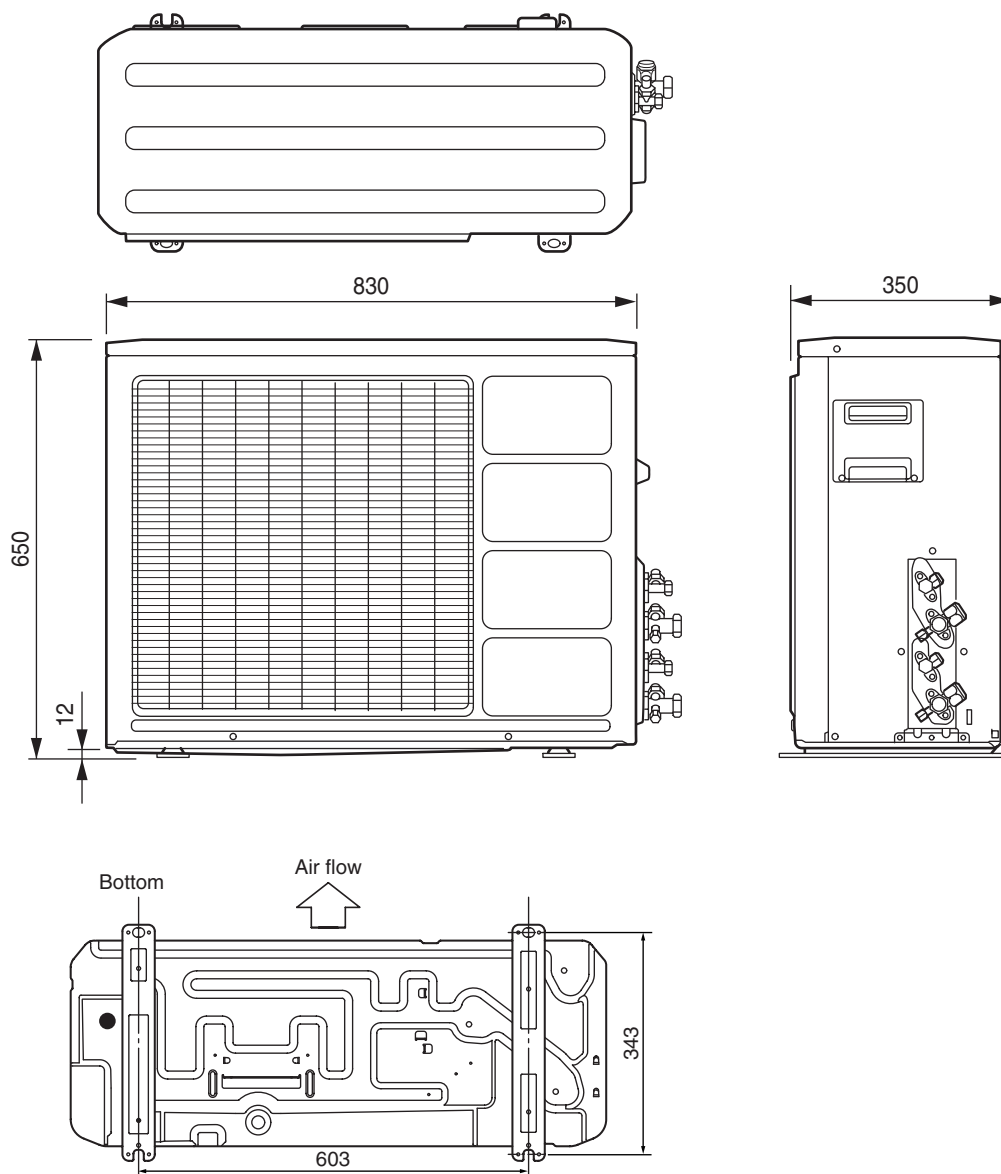

REFRIGERANT SYSTEM DIAGRAM

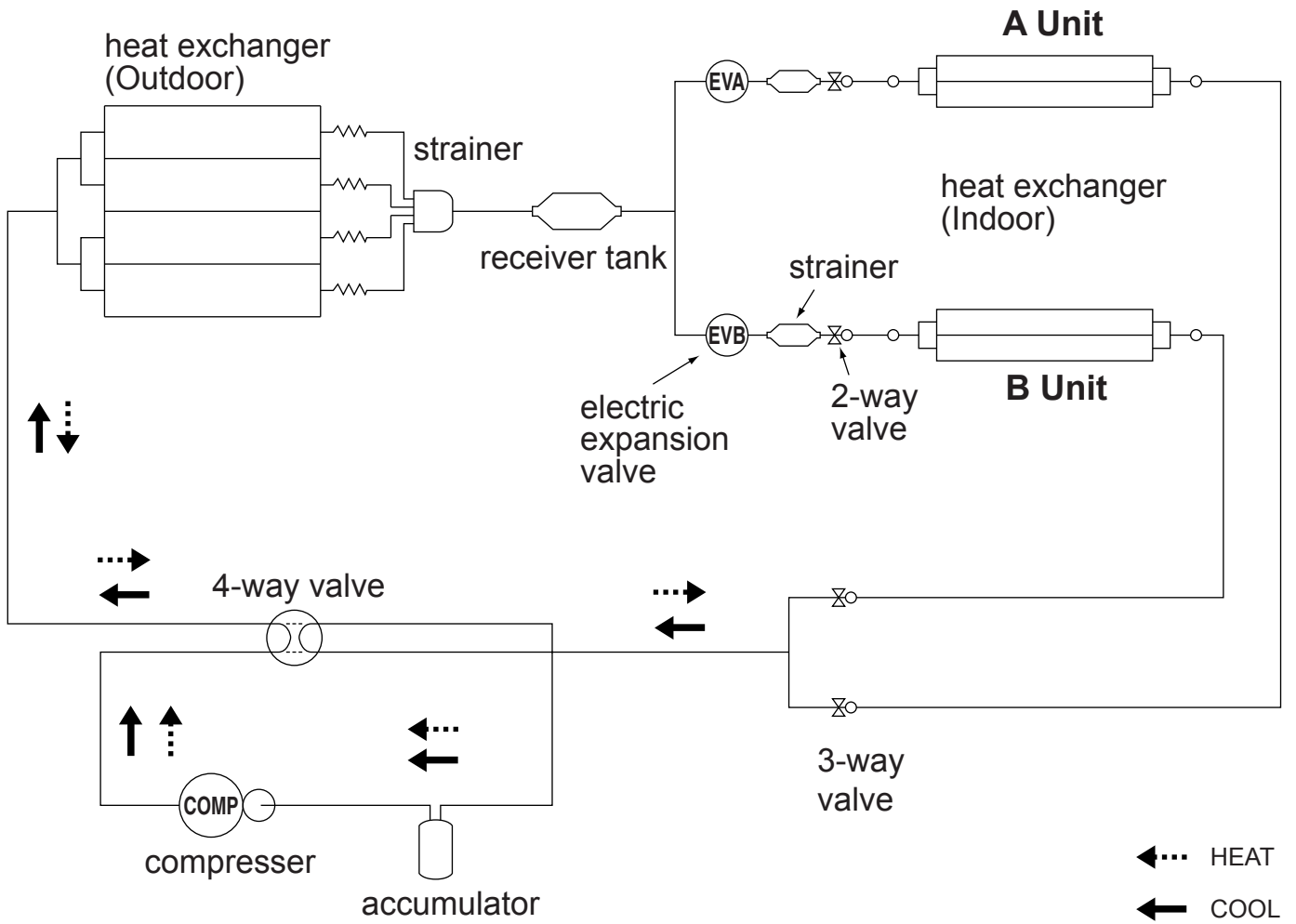

CIRCUIT DIAGRAM

Model : ABY14LBAJ

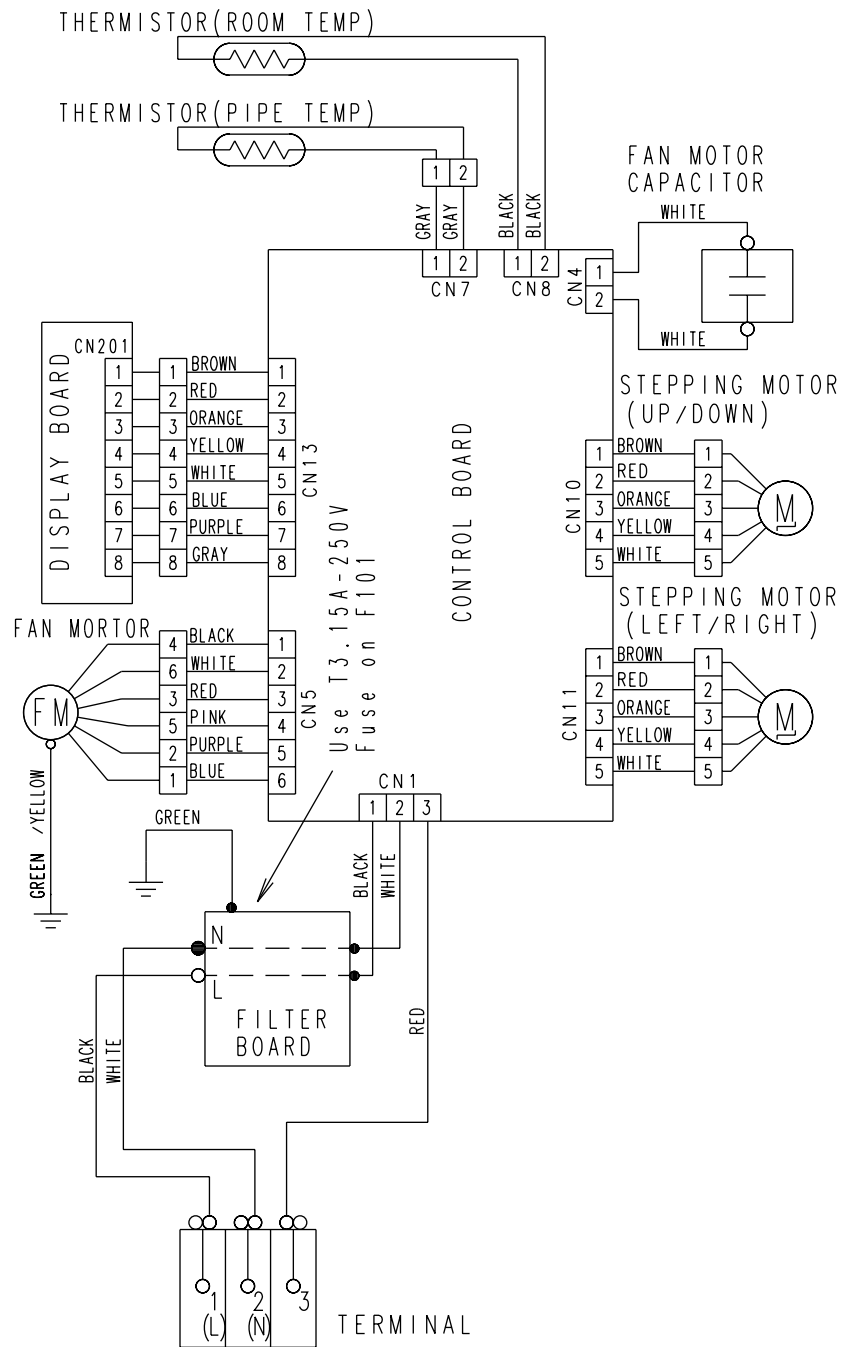

OUTDOOR UNIT

Model : AOY18LMAK2

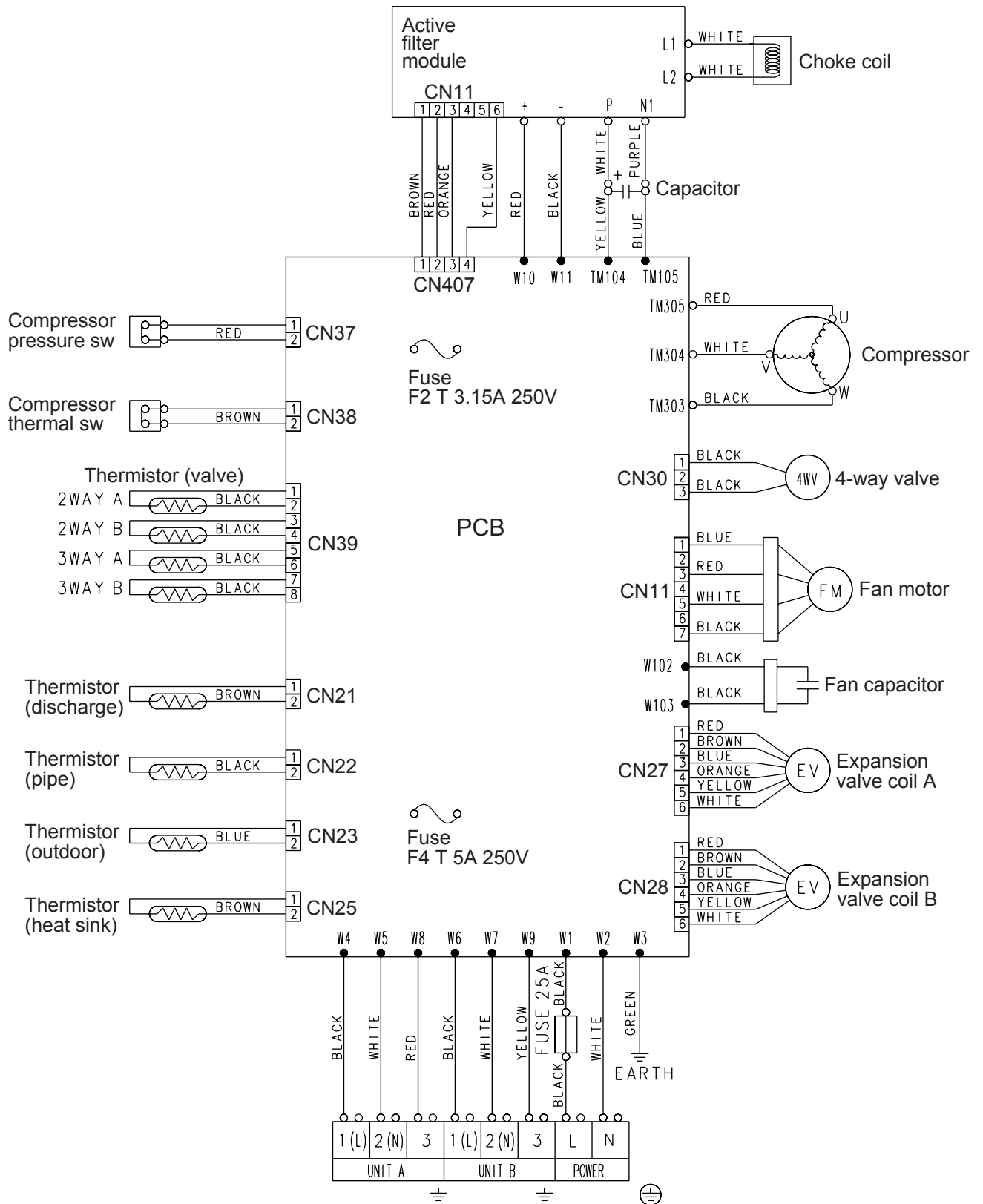

INDOOR PCB CIRCUIT DIAGRAM

Model : ABY14LBAJ

CONTROLLER PCB ASSY

K01AL-0414HSE-F1

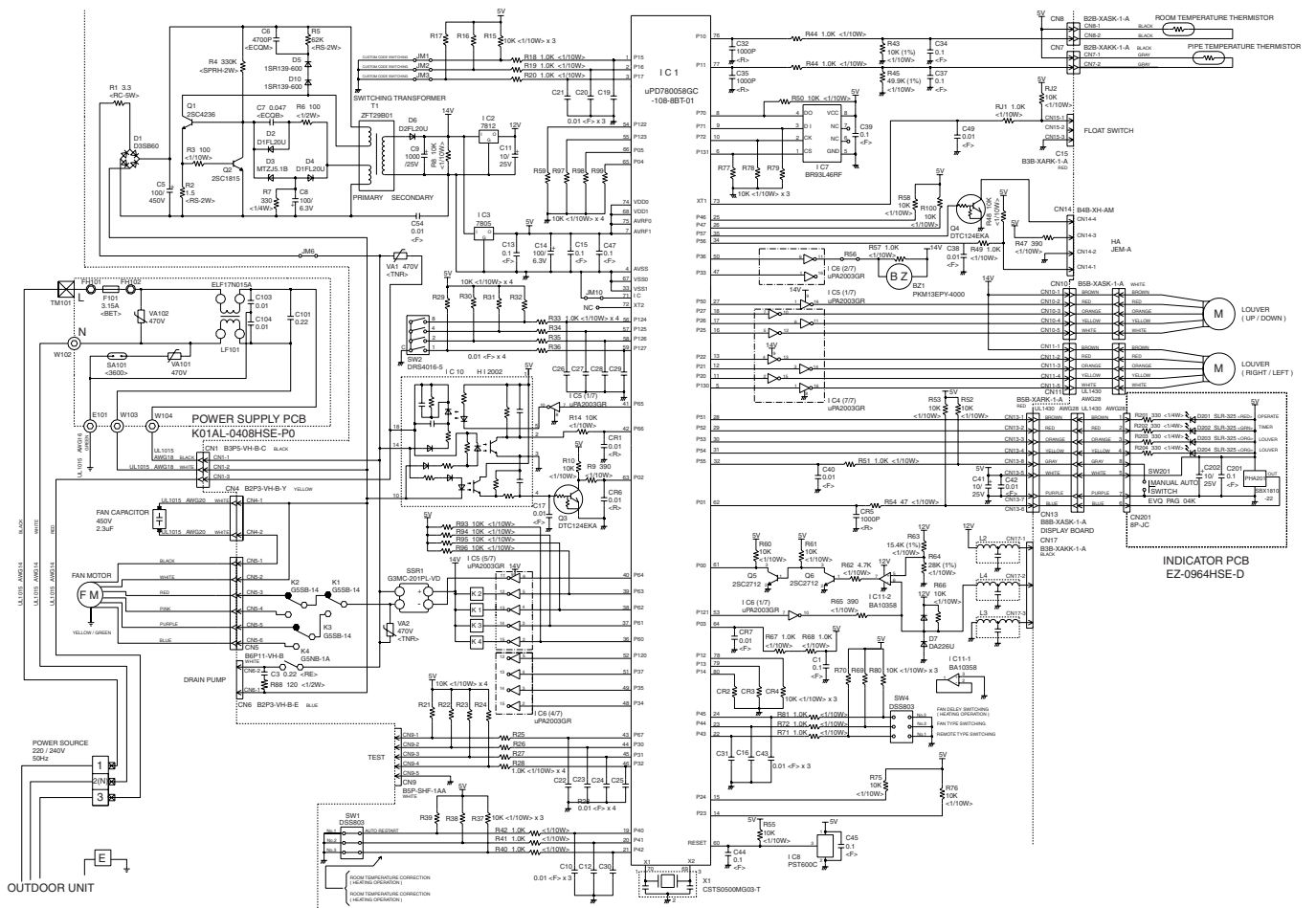

OUTDOOR PCB CIRCUIT DIAGRAM

Model : AOY18LMAK2

CONTROLLER PCB ASSEMBLY (MAIN PCB)
K03AV-0500HUE-C1

CHOKO COIL
L=3.9M 30A

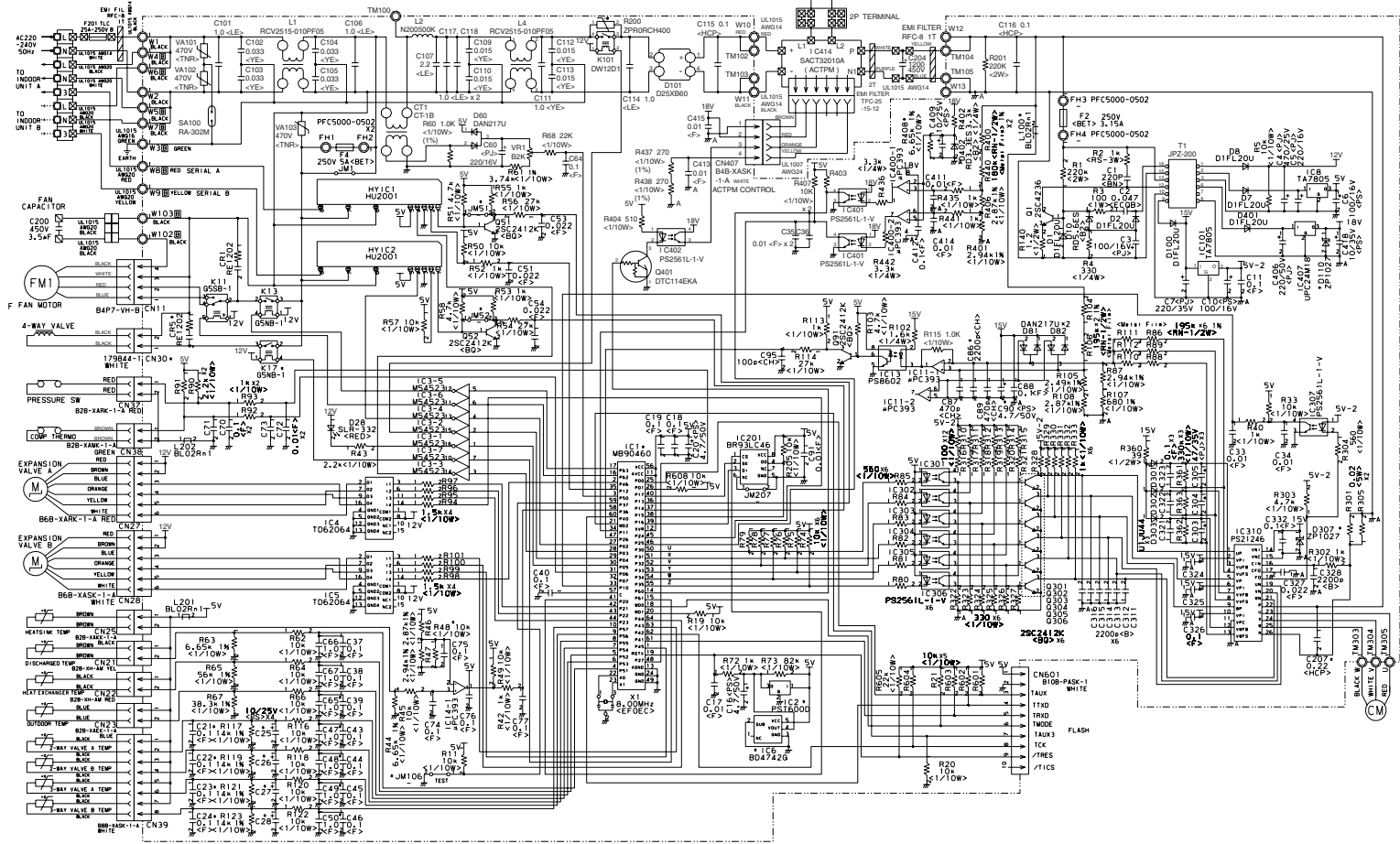

ERROR CONTENTS

The OPERATION, TIMER and SWING lamps operate as follows according to the error contents.

Error contents	Error display		
	OPERATION (RED)	TIMER (GREEN)	SWING (ORANGE)
Indoor unit circuit board error	○	○	—
Indoor unit room temperature sensor wire opened	2 times ●	○	—
Indoor unit room temperature sensor wire short circuited	2 times ●	○	○
Indoor unit piping sensor wire opened	3 times ●	○	—
Indoor unit piping sensor short circuited	3 times ●	○	○
Outdoor unit → Indoor unit communication error	5 times ●	○	—
Indoor unit → Outdoor unit communication error	5 times ●	○	○
Indoor unit fan error	6 times ●	○	—
Outdoor unit heat exchanger temperature sensor error	○	3 times ●	—
Outdoor unit outdoor temperature sensor error	○	4 times ●	—
Outdoor unit discharge temperature sensor error	○	5 times ●	—
Outdoor unit compressor temperature sensor error	○	8 times ●	—
Outdoor unit pressure switch error	○	9 times ●	—
Outdoor unit 2 way valve temperature sensor error	○	—	2 times ●
Outdoor unit 3 way valve temperature sensor error	○	—	3 times ●
Indoor unit fan connection capacity error	○	—	4 times ●
IPM error	○	10 times ●	—
Compressor later location error	○	13 times ●	—
Outdoor fan motor error	○	14 times ●	—

○ : Fast flashing ● : Slow flashing — : Off

DISASSEMBLY ILLUSTRATION

Model : ABY18LBAJ

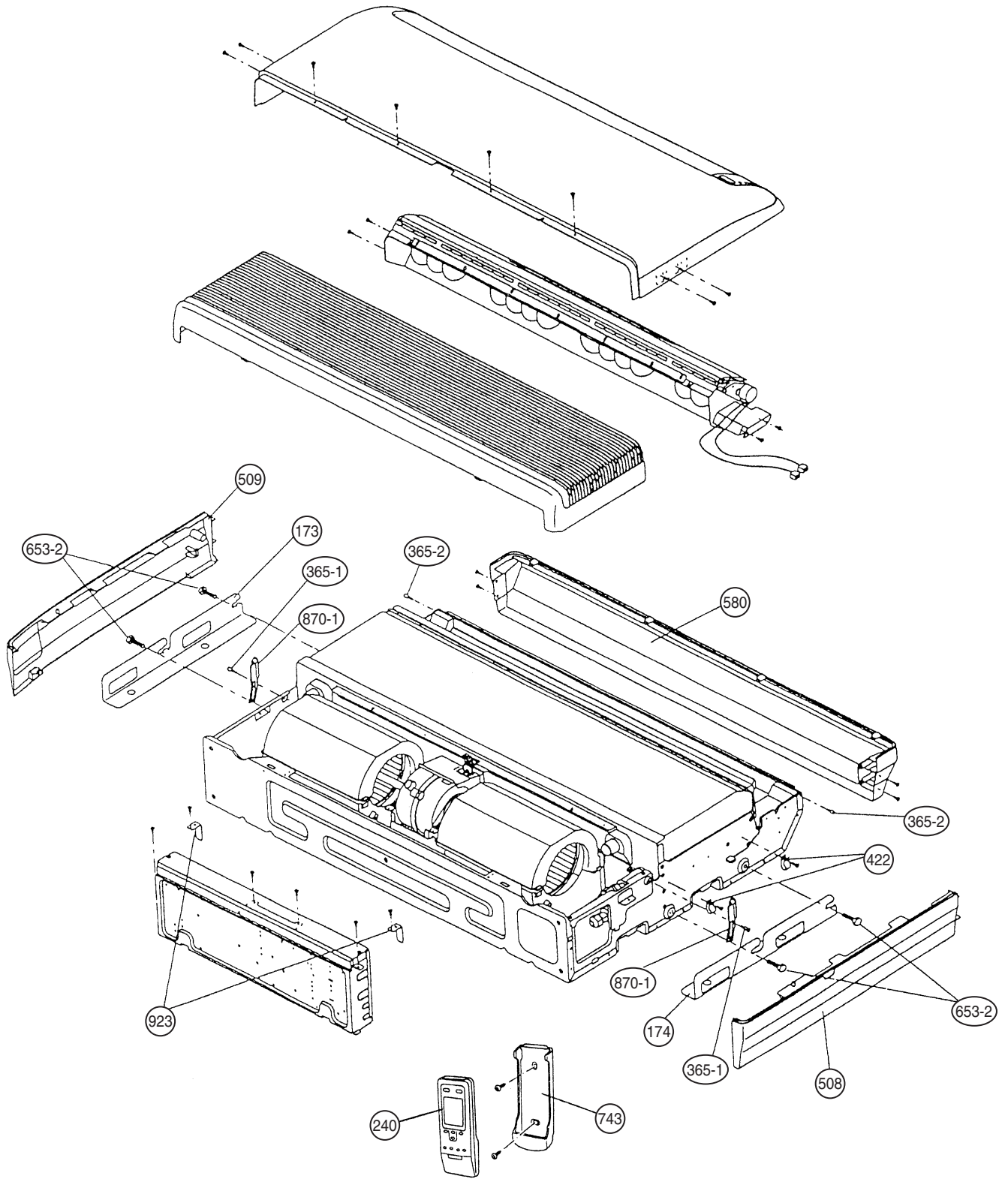

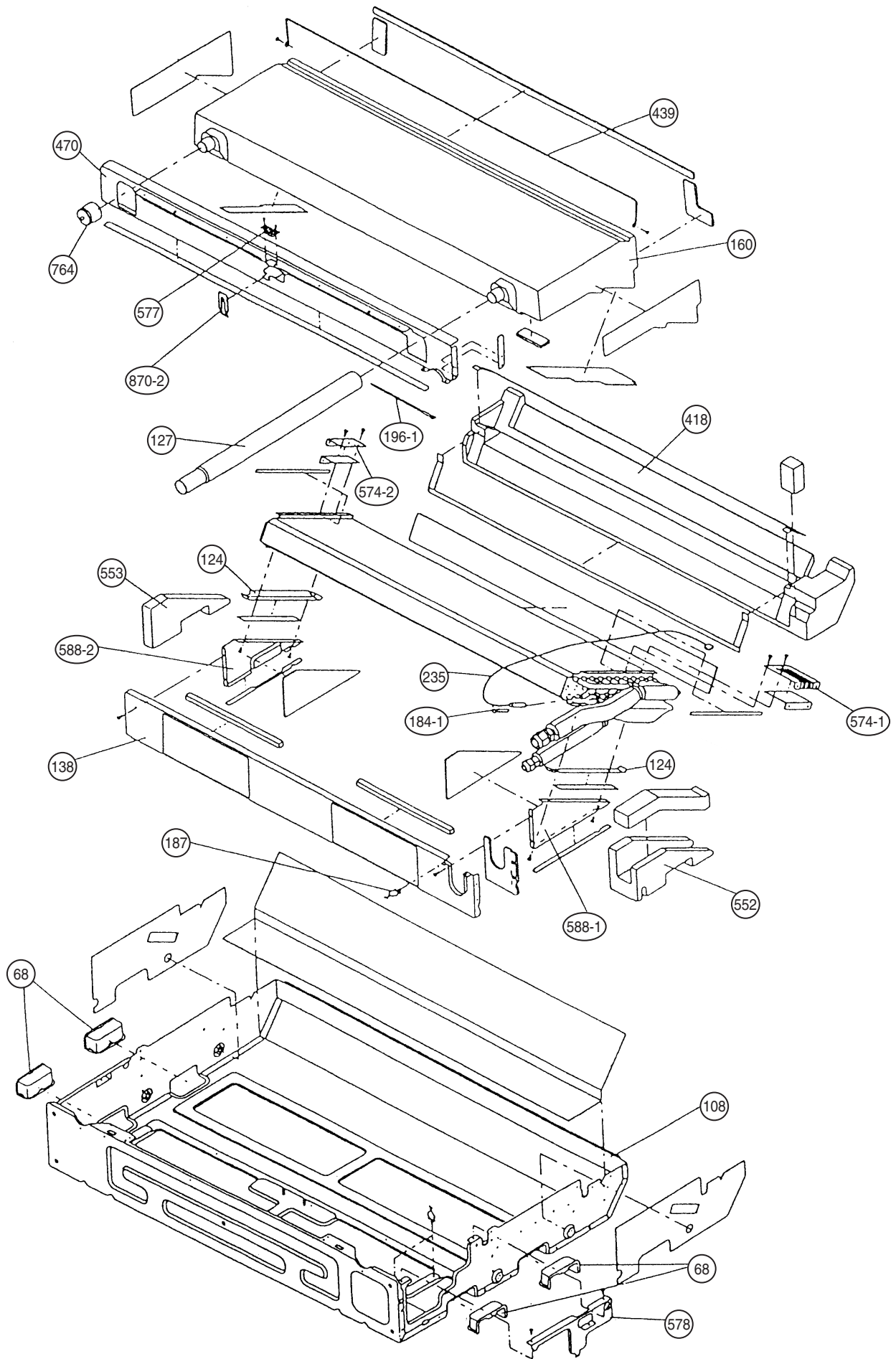

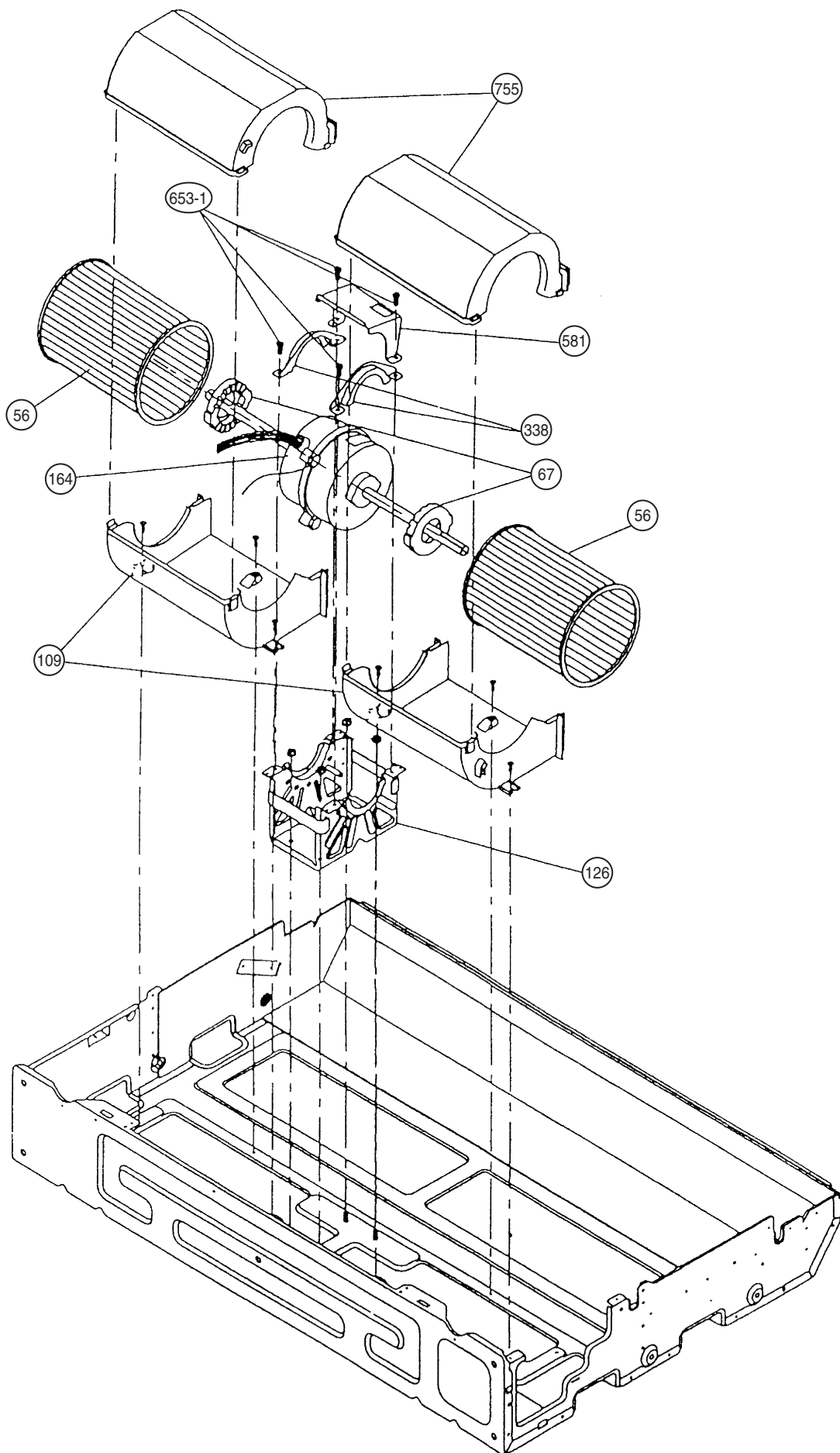

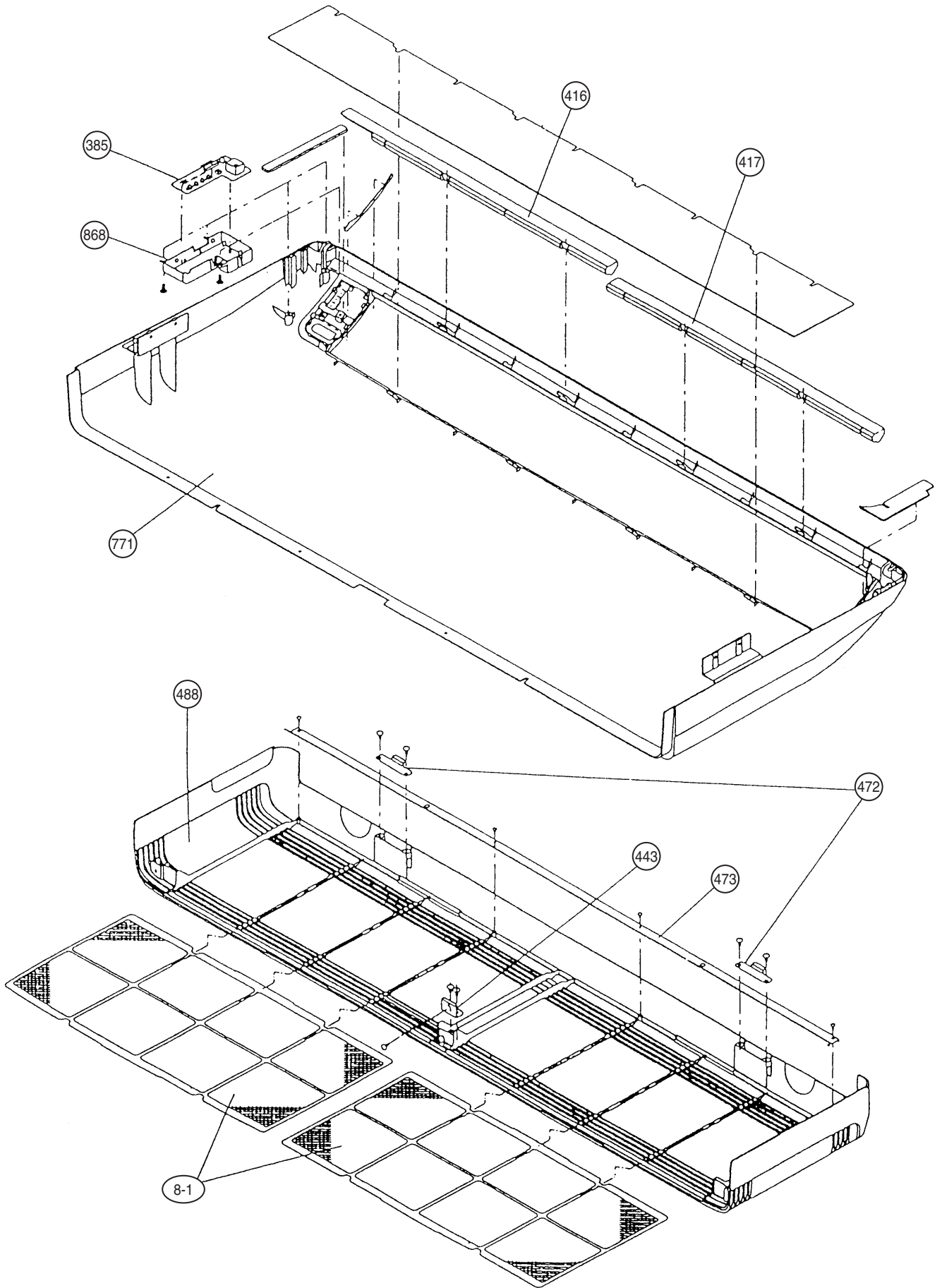

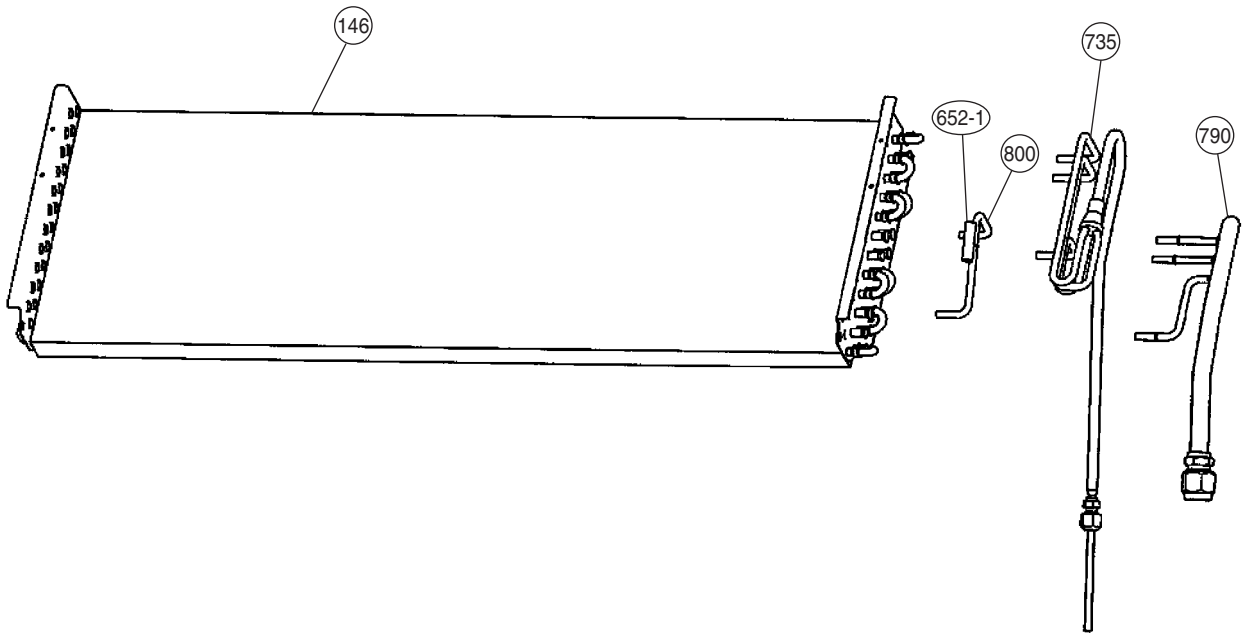

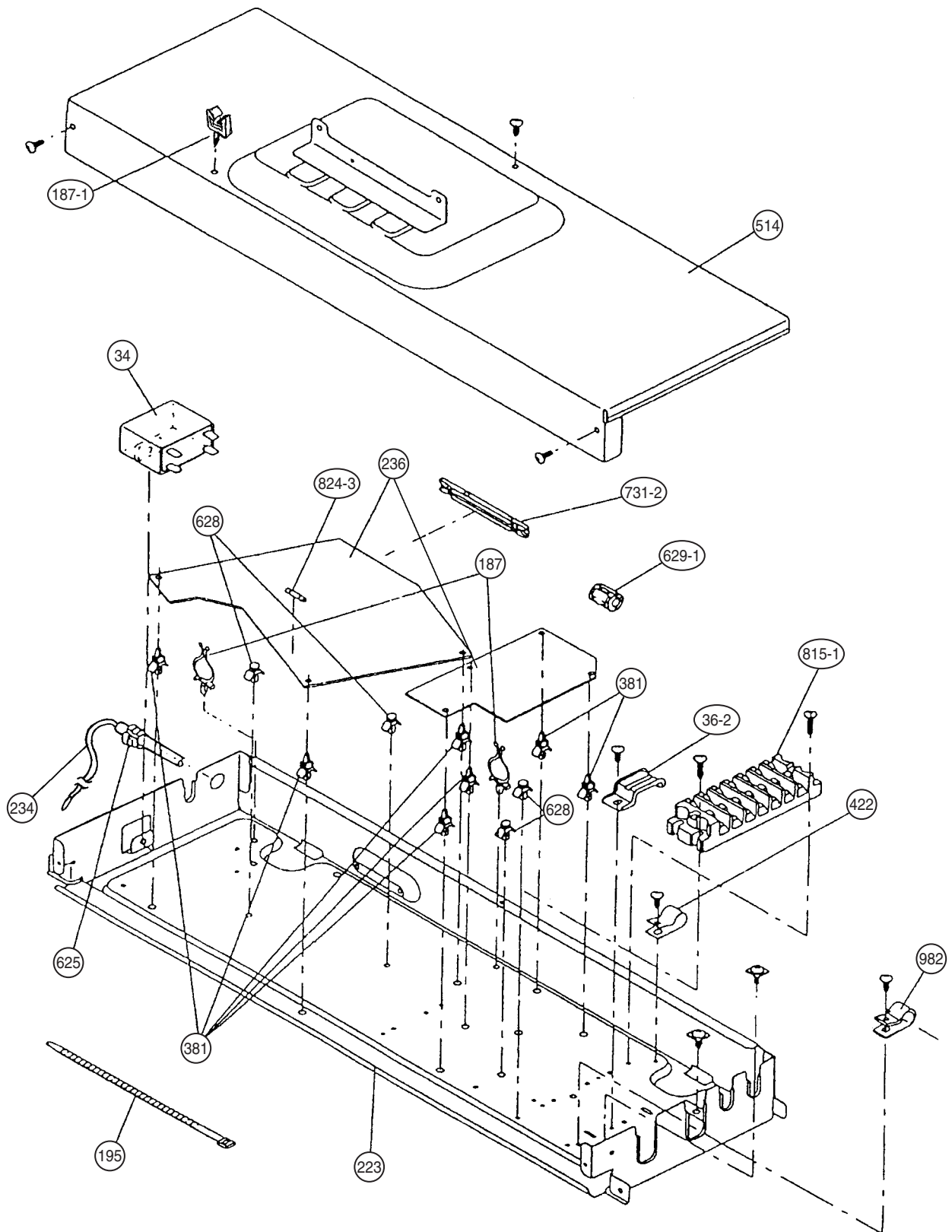

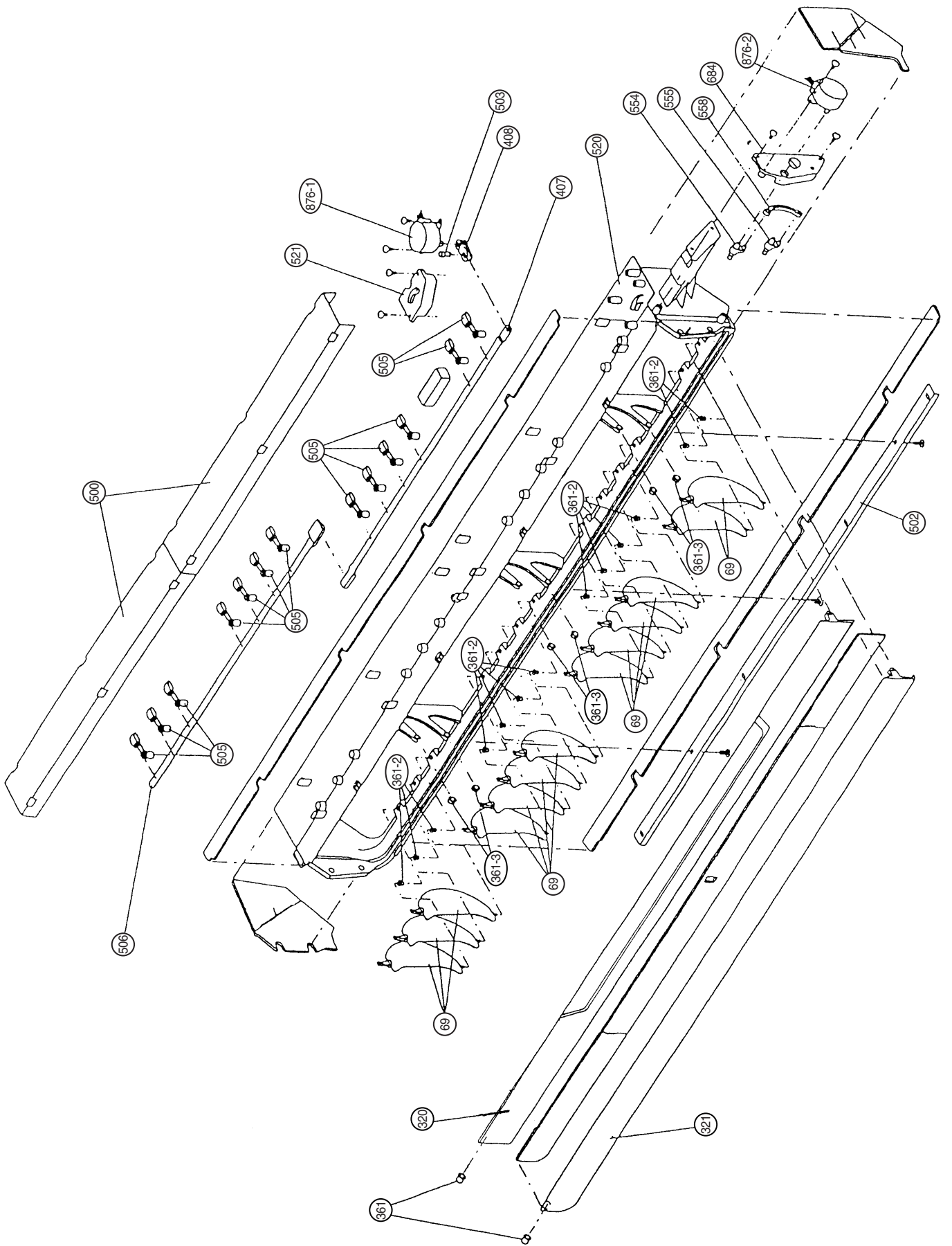

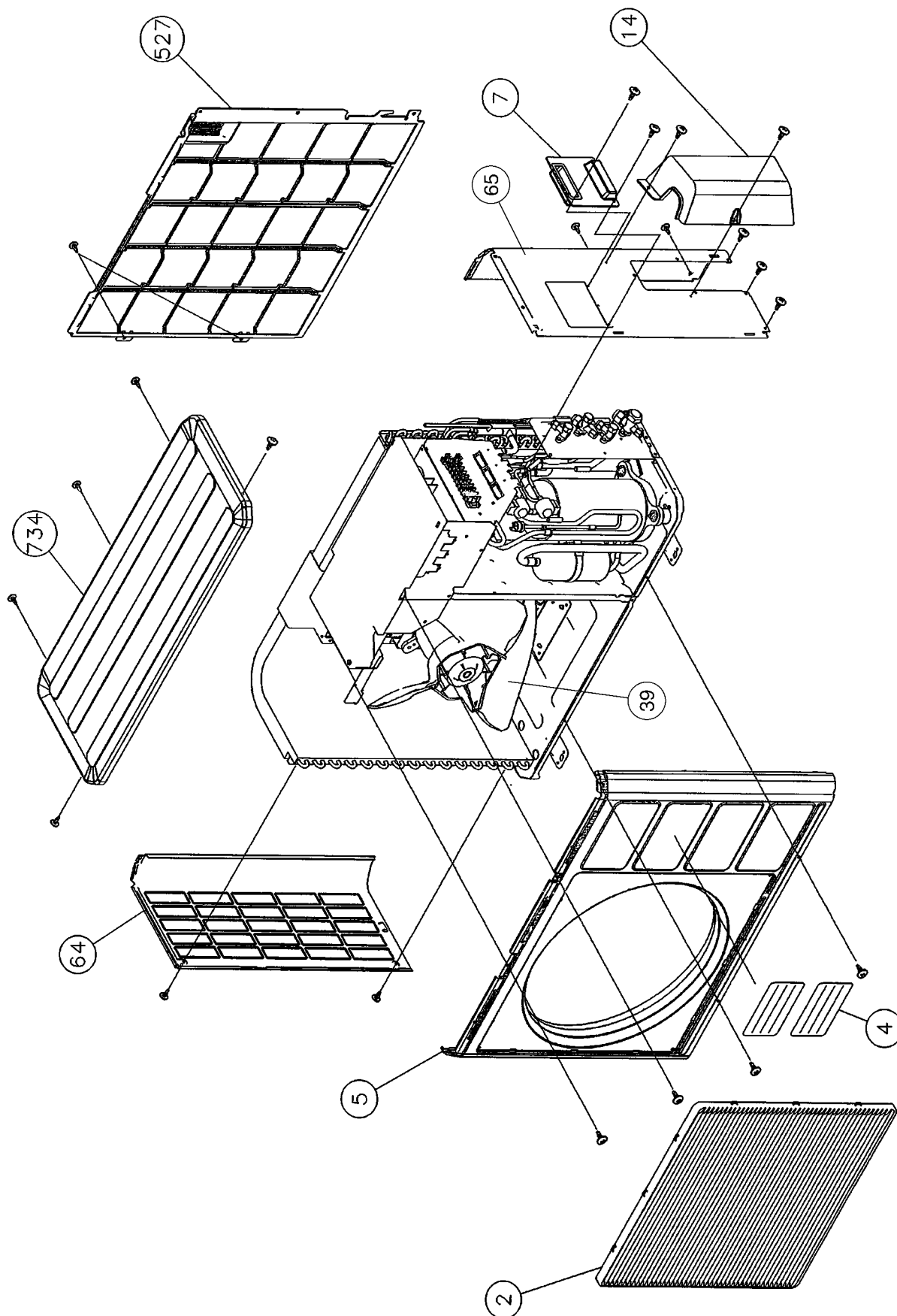

Model : AOY18LMAK2

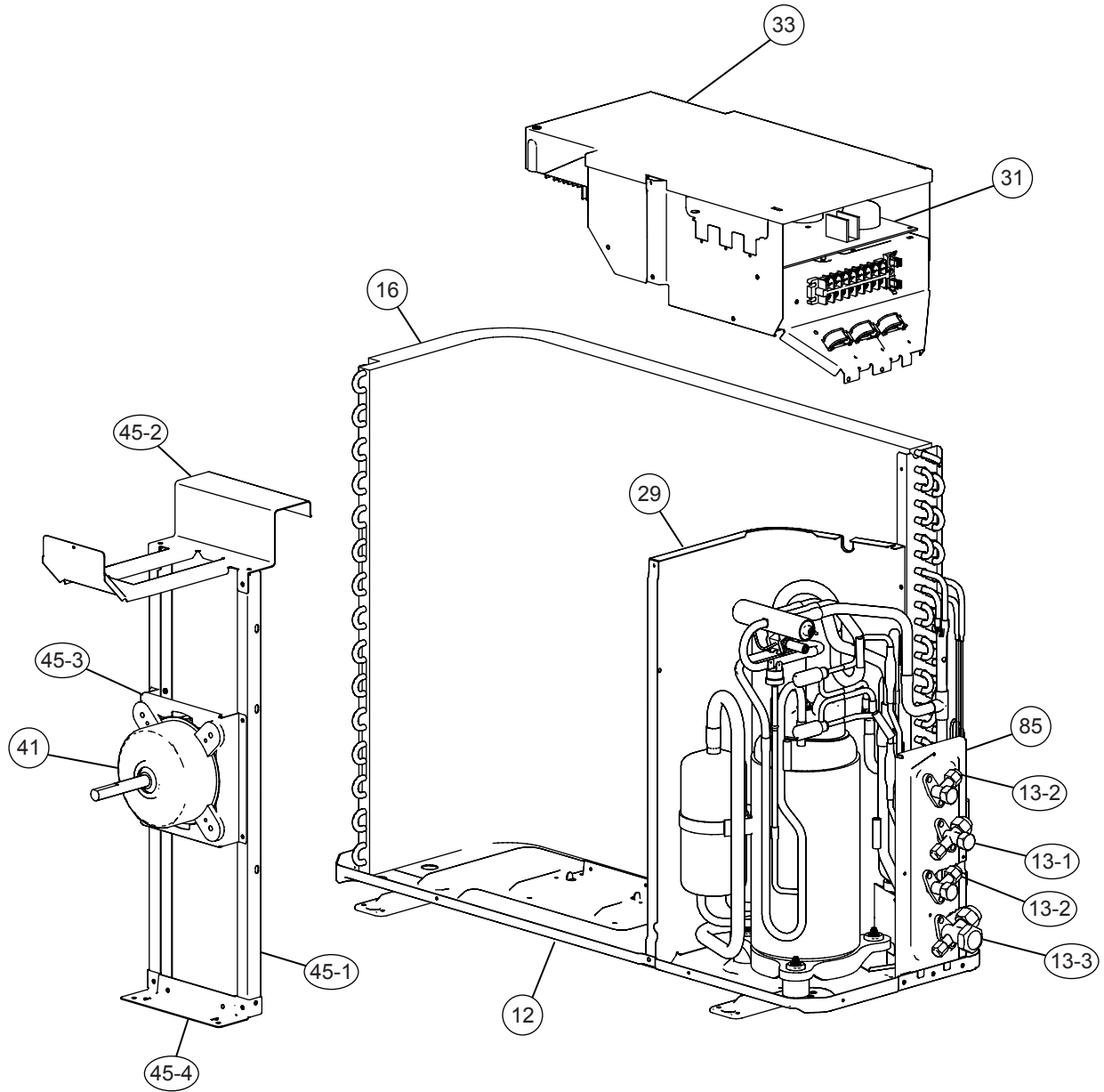

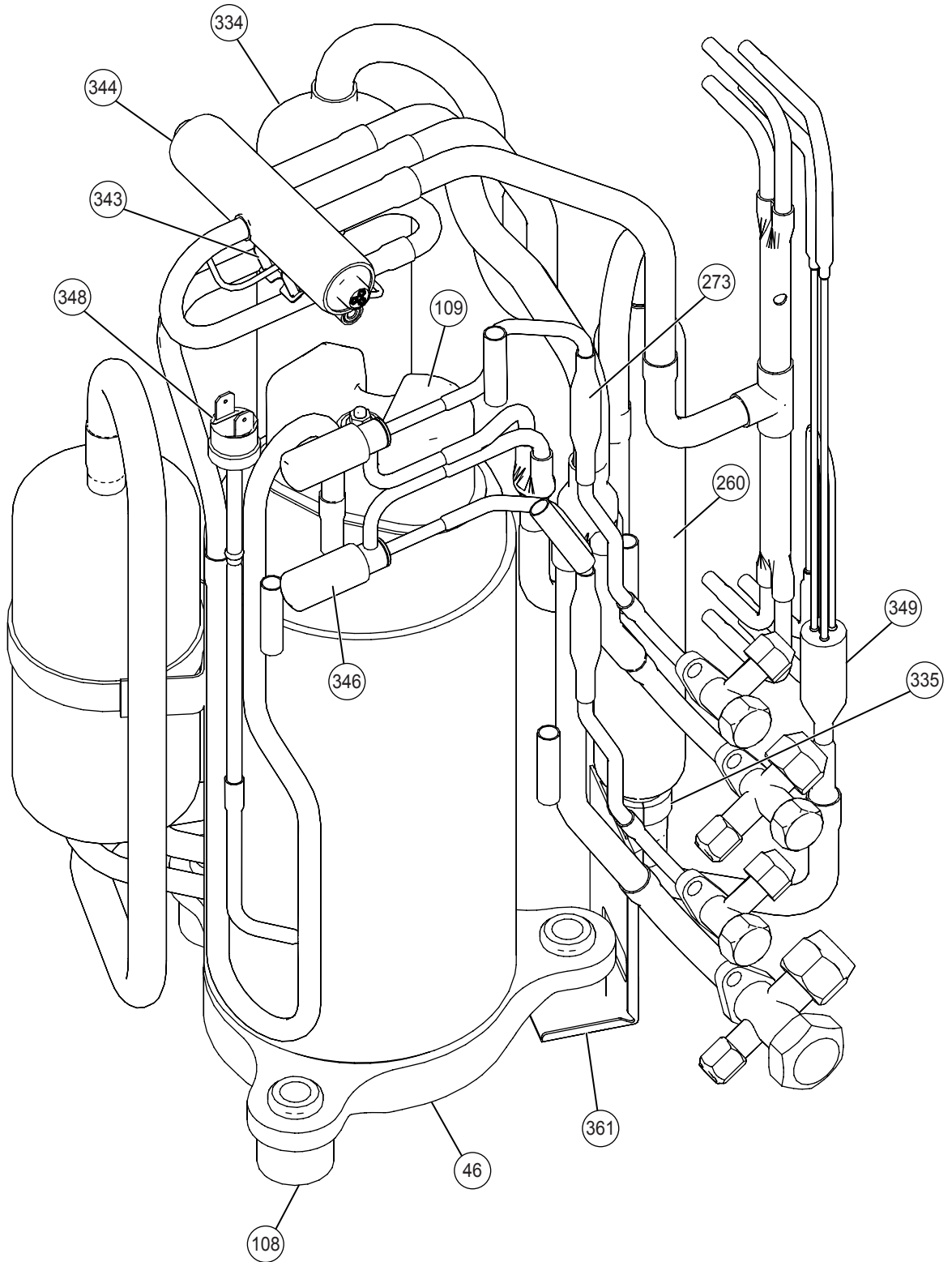

Model : AOY18LMAK2

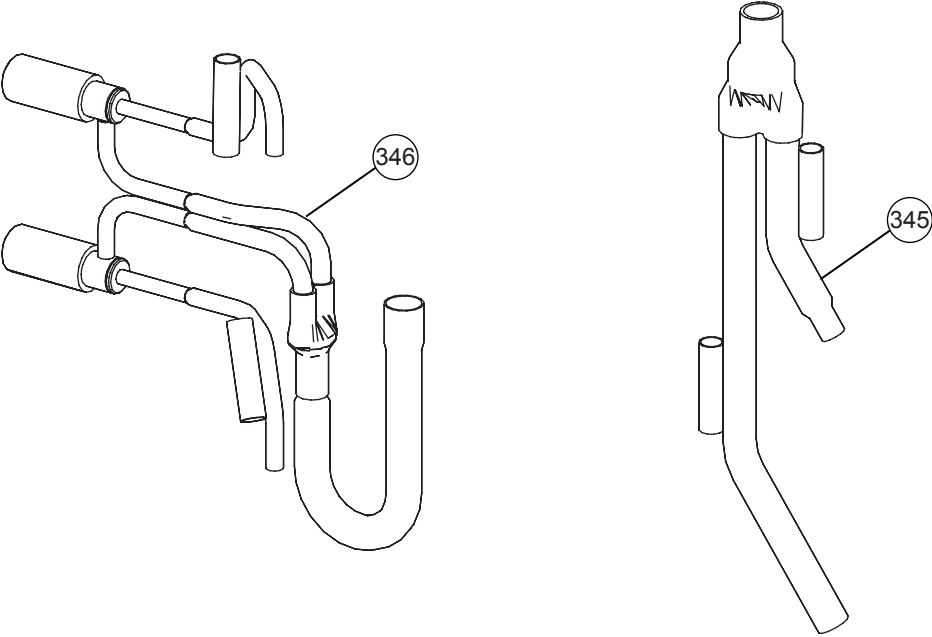
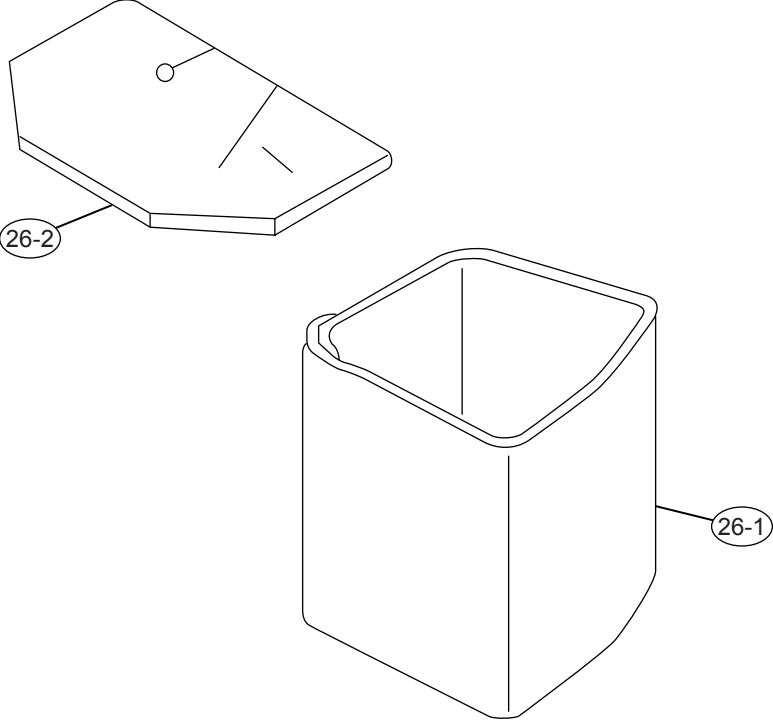

PARTS LIST

INDOOR UNIT

Ref. No.	Description	Part No.	Ord.	Ref. No.	Description	Part No.	Ord.
		ABY14LBAJ	Q'ty			ABY14LBAJ	Q'ty
8-1	Air Filter	9358567029		473	Filter Bracket	9358607008	
34	Capacitor (Fan Motor) 1.6μF/400V	9900270018		488	Grill-F	9358532010	
36-2	Cord Holder Metal	9356362008		500	Protect Cover	9358564004	
56	Sirocco Fan Assy	9385258006		502	Support Stay	9358599006	
67	Rubber (Vibration-proof)	9385102002		503	Louver Shaft	9358557006	
69	Louver	9358561010		505	Louver Stopper	9358555002	
68	Cap, Plastic	9358563007		506	Louver Rod	9358559000	
108	Base Assy	9359061038		508	Cosmetic Panel-R	9358535011	
109	Casing, Plastic	9358543009		509	Cosmetic Panel-L	9358536018	
124	Dew Proof Plate	9359196006		514	Control Box Cover	9359097006	
126	Motor Fixing Table Assy	9358591000		520	Flap Base	9358537015	
127	Drain Hose Assy	9359242000		521	Louver Link Cover	9358558003	
138	Separate Wall-A	9358584002		552	Insulation (Eva.)-R	9358575000	
146	Evaporator Assy	9362513029		553	Insulation (Eva.)-L	9358857007	
160	Drain Pan Assy	9358568002		554	Flap Link-Upper (Step Motor-V)	9358551004	
164	Fan Motor Assy-IN	9601527039 (MFA-14JTT)		555	Flap Link-Lower (Step Motor-V)	9358552001	
173	Hanger Bracket-L	9358596005		558	Motor Rod-A (Step Motor-V)	9358550007	
174	Hanger Bracket-R	9358595008		574-1	Evaporator Fixture-R (Bracket)	9358589007	
184-1	Thermistor Spring-A	313728262708		574-2	Evaporator Fixture-L (Bracket)	9358590003	
187	Clamp No. 1219	313361271706		577	Catch TL-119	9359096009	
187-1	Clip (Cable)	9352715006		578	Base Bracket (Reinforcement Metal)	9358586006	
195	Clamp SKB-100	313361275805		580	Top Cover	9358534014	
196-1	Clamp SKB-3M	312300787605		581	Protector, Metal (Fan Motor)	9359282006	
223	Control Box	9358600016		588-1	Evaporator Bracket-R	9358587003	
234	Thermistor Assy-Room	9703299087		588-2	Evaporator Bracket-L	9358588000	
235	Thermistor Assy-Pipe	9900022020		625	Cord Bushing KR-51	9359240006	
236	Controller PCB Assy	9705914018 (K01AL-0414HSE-F1)		628	Locking Spacer-B	313005446558	
240	Remote Control Unit AR-JW1	9371190013		629-1	EMI Filter	0400247074	
320	Flap (Upper)-F	9358538012		652-1	Thermistor Holder Pipe	313806262805	
321	Flap (Lower)	9358541012		653-1	Bolt (Fan Motor Fixing)	0700156014	
338	Motor Fixture	9358594001		653-2	Bolt	0700190018	
361	Bushing	9357942001		684	Motor Base	9358562000	
361-2	Bushing-B, Plastic	9358554005		731-2	Holder (Guide Rail)	0600241018	
361-3	Bushing-C, Plastic	9358553008		735	Distributor As	9373034018	
365-1	Special Screw	9359092001		743	Remote Control Unit Holder	9305642014	
365-2	Special Screw	9359091004		755	Casing Cover	9358544006	
381	Locking Spacer, KGLS-4S	313209391506		764	Drain Cap	9358746004	
385	Indicator PCB Assy EZ-0964HSE-D	9701873012		771	Panel Assy	9359076117	
407	Motor Rod	9358560006		800	Bypass Pipe Assy	9373032014	
408	Louver Link	9358556009		815-1	Terminal 3P	9900203016	
416	Insulation (Panel)-A	9358574003		824-3	Fuse BET3.15A - 250V	0600222512	
417	Insulation (Panel)-B	9358914007		868	PCB Holder	9358547007	
418	Insulation (Flap Base)	9358572009		870-1	Arm	9358565001	
422	Clamp NK-10N	9359183006		870-2	Center Arm	9359280002	
439	Drain Pan Wire	9358598009		875	Power Supply PCB Assy	9704561190 (K01AL-0408HSE-PO)	
443	Arm Bracket	9359281009		876-1	Step Motor-H	9359106012	
470	Separate Wall-B	9358585009		876-2	Step Motor-V	9359105015	
472	Grille Support	9358602003		923	Control Box Bracket	9358717004	
				982	Cord Clamp	9357886008	

OUTDOOR UNIT

Ref. No.	Description	Part No.	Ord. Q'ty	Ref. No.	Description	Part No.	Ord. Q'ty
		AOY18LMAK2				AOY18LMAK2	
2	Fan Guard	9371187013		335	Accumulator Holder Rubber	9354022010	
4	Emblem	9351355005		343	Solenoid	9900165079	
5	Front Panel	9371924014		344	4-Way Valve	9900163013	
7	Connecteur Cover (Cabinet)	9366398004		345	Joint Pipe (3Way) Assy	9373729129	
12	Base Assy	9371920078		346	Expansion Valve Assy	9373729068	
13-1	3-Way Valve	9372205044		348	Pressure Switch Assy	9373729044	
13-2	2-Way Valve	9372204054		349	Capirally Assy	9373729211	
13-3	3-Way Valve	9372205051		361	Accum Support Assy	9372252017	
14	Valve Cover	9372796016		527	Protective Net	9371934013	
16	Condenser Assy	9372181096		734	Top Panel	9372304013	
26-1	Compressor Cover A	9373730019		---	Gasket (Comp)	9373266013	
26-2	Compressor Cover B	9373730026		---	Washer (Rubber) (Comp)	9358078006	
29	Separate Wall	9372795019		---	Compressor pressure switch	9900186012	
31	Controller PCB Assy	9705285057		---	Compressor thermal switch	9373263012	
33	Control Cover	9372792018		---	Thermistor Valve	9900194017	
39	Propeller Fan Assy	9366378013		---	Thermistor discharge	9704219039	
41	Motor Induct	9601671046		---	Heat exchanger thermistor	9704220059	
45-1	Motor Bracket	9371929019		---	Thermistor outdoor	9703516047	
45-2	Motor Bracket-Top	9371931012		---	Thermistor heat sink	9900195014	
45-3	Motor Bracket-Center	9371930015		---	Special Nut M8 (Comp)	9355091008	
45-4	Motor Bracket-Bottom	9371932019		---	Condenser Sub Assy	9372313121	
46	Compressor Assy	9373262015		---	Thermister Holder Pipe	313714262805	
64	Side Panel L	9371926018		---	Capacitor, Plastic	9704305077	
65	Side Panel R	9371927015		---	Clip (Cable)	9352715006	
85	Valve Plate	9371928036		---	Br Sheet	9363708042	
108	Rubber Seat (Comp)	9358080009		---	Relay	9900117016	
109	Terminal Cover (Comp)	9373264019					
260	Receiver Tank Assy	9373426011					
273	Strainer Assy	9366602019					
334	Accumulator	9368391003					











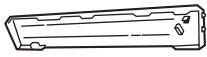

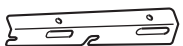
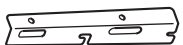
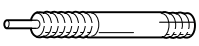

Inverter Assy

Ref. No.	Description	Part No.	Ord. Q'ty
31	Controller PCB Assy	9705285057	
---	ACTPM	9703457012	
---	Capacitor, Elec	9705387010	
---	Capacitor, Plastic	9704305077	
---	Fuse	0600086039	
---	Terminal 8P	9900203047	
---	Fuse Holder	0501454012	
---	Terminal 2P	9701971015	

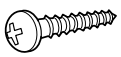
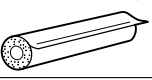

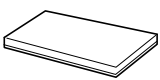

STANDARD ACCESSORIES

The following installation parts are furnished. Use them as required.

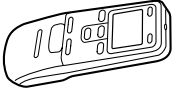

INDOOR UNIT ACCESSORIES

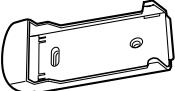
Name and Shape	Q'ty	Application	Part No.
Cosmetic Panel-L 	1		9358536018
Cosmetic Panel-R 	4		9358535011
Tapping screw (φ 4 x 10) 	2		301171164104
Installation template 	1	For positioning the indoor unit. For under ceiling type.	9359107002
Hanger bracket (left) 	1	For suspending the indoor unit from ceiling.	9358596005
Hanger bracket- (right) 	1		9358595008
Anchor bolt (M12) 	4		313806339400
Special nut 	4		
Spring washer 	4		301821112213
Wall bracket 	2	For suspending the indoor unit on the wall.	9358597002
Tapping screw (φ 4 x 20) 	6	For fixing the wall bracket.	301141164200
Coupler heat insulator (large) 	1	For indoor side pipe joint. (Large pipe)	9350716012
Coupler heat insulator (small) 	1	For indoor side pipe joint. (Small pipe)	313209328104
Nylon fastener (small) 	1	For fixing the drain hose.	312300787605
Drain hose 	1		9359242000
Insulation (drain hose) 	1	Adhesive type 70 x 230	9359225003
VT wire 	1	For fixing the drain hose L 280 mm	313806350303

REMOTE CONTROL UNIT

Name and Shape	Q'ty	Application	Part No.
Remote control unit 	1	Use for air conditioner operation (AR-JW1)	9371190013
Battery (penlight) 	2	For remote control unit	0600185534
Remote control unit holder 	1	For mounting the remote control unit	9305642014
Tapping screw (ϕ 3 x 12) 	2	For remote control unit holder installation	301141533125

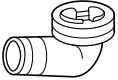
OUTDOOR UNIT ACCESSORIES

Name and Shape	Part No.
Drain pipe 	9303029015
Drain cap 	313166024302
Adapter D (1/2" → 3/8") 12.7mm → 9.52mm 	9370244007

0507G2880