

Heat pump systems EOS GREEN



fiorini

Air-water heat pumps for DHW production EOS GREEN

EOS GREEN is the hot water heater for the production of hot water: water heating is carried out by a rotary compressor heat pump and a condensate coil outside the tank. A 2 kw auxiliary electric resistance is supplied as standard to make water heating faster if necessary.

Available in two versions:

- EOS GREEN 2 (200l)
- EOS GREEN 3 (270l)



Storage tank characteristics:

Material: carbon steel S 235 JR

Internal protective coating: inorganic glass lining (norm DIN 4753.3)

Insulation: thermal insulation in rigid high density polyurethane

Functions

- ✓ Production of hot water up to 55°C (75°C with resistor)
- ✓ Built-in monoblock structure
- ✓ Touch screen control
- ✓ ECO function: only heat pump
- ✓ PARTY function: heat pump + electric resistance
- ✓ Antilegionella: heat treatment of sanitation
- ✓ Integrated Solar Thermal Management
- ✓ Integrated thermal solar heat exchanger
- ✓ Possibility of channeling the aspirated / expelled air
- ✓ Built-in auxiliary electrical resistance management



TESTED



Model	Code	Price
EOS GREEN 2	844020016X	
EOS GREEN 3	844020017X	

EOS GREEN heat pump accessories		
Model	Code	Price
Canalization Kit**	844070022X	

** (10 meters of aluminum hub 160mm diam 160mm double wall + stainless steel clamps)

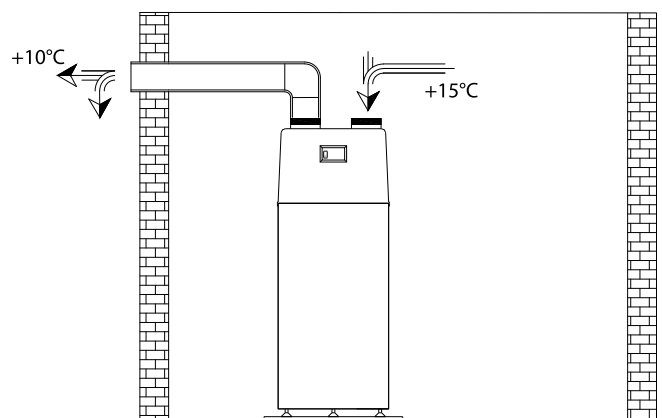

Air-water heat pumps for DHW production EOS GREEN

Technical data

		EOS GREEN 2	EOS GREEN 3
Capacity	l	200	270
Thermal power*	kW	2	2
Absorbed power* (only heat pump)	kW	0,4	0,4
Power supply	V/Ph/Hz	230/1/50	230/1/50
Built-in resistor power	kW	2	2
Overall power (heat pump + resistor)	kW	4	4
Maximum current consumption	A	10,7	10,7
Q _{elec} Daily energy consumption	kWh	3,145	5,677
Degree of protection		IP22	IP22
Electrical protection		C16	C16
COP *		3,49	3,06
COP **		3,76	3,36
Energy label		A	A
Water consumption profile (EN-16147)		L	XL
Air flow	m ³ /h	365	365
Suction air temperature min/max	°C	+7/+35	+7/+35
Air pipe diameter	mm	160	160
Max pipe length	m	10	10
Max DHW temperature	°C	55	55
Max DHW temperature (with resistor)	°C	75	75
Max operating temperature of the tank	°C	95	95
Max operating temperature of the exchanger	°C	110	110
Max operating pressure of the tank	bar	10	10
Max operating pressure of the exchanger	bar	16	16
Water inlet / outlet connection diameter	inch	1"	1"
Recirculation connections diameter	inch	3/4"	3/4"
Condensate drain connection diameter	mm	12	12
Integrative heat exchanger		1	1
Heat exchanger surface (solar)	m ²	1	1
Coolant		R134a	R134a
Coolant load	kg	1,2	1,2
Compressor type		rotary	rotary
Number of compressors		1	1
Sound pressure	db(A)	56	56
Set-up time only HP	h	4	5
Set-up time HP + RES.	h	2	2
Packaging weight	kg	143	160,5
Dimensions (Ht x Øe)	cm	150x67	173x67
Packaging dimensions (Wt x Lt x Ht)	cm	80x83x180,5	80x83x191,5



Conditions

* EN-16147 T air 15°C, T water from 10°C to 55°C

** EN-16147 T air 20°C, T acqua from 10°C to 55°C

Air-water heat pumps for DHW production EOS GREEN

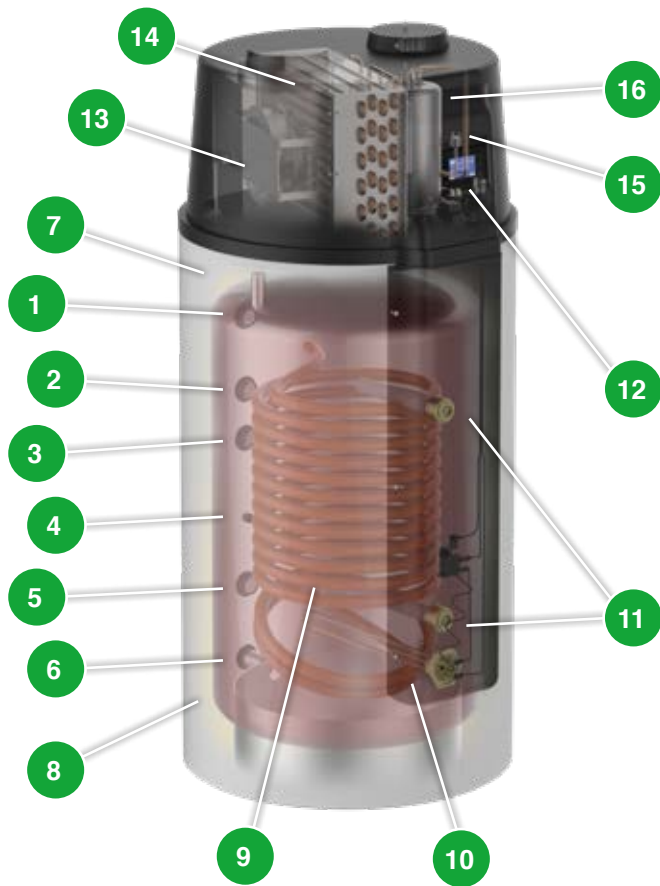

Components

- | | |
|----|-----------------------|
| 1 | DHW outlet |
| 2 | Heat exchanger inlet |
| 3 | Recirculation |
| 4 | Probe |
| 5 | Heat exchanger outlet |
| 6 | Cold water inlet |
| 7 | Condensation drain |
| 8 | Insulation |
| 9 | Heat exchanger |
| 10 | Resistor |
| 11 | Anodes |
| 12 | Control panel |
| 13 | Fan |
| 14 | Evaporator |
| 15 | Filter |
| 16 | Compressor |

EOS GREEN 2

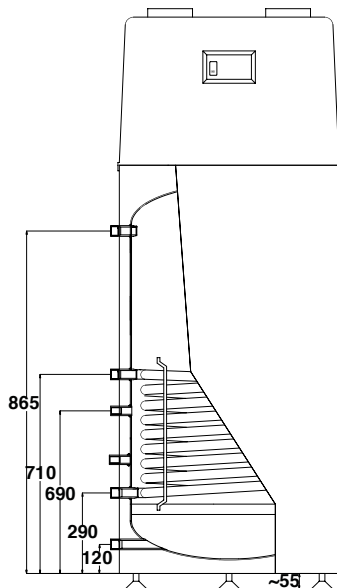

EOS GREEN 3

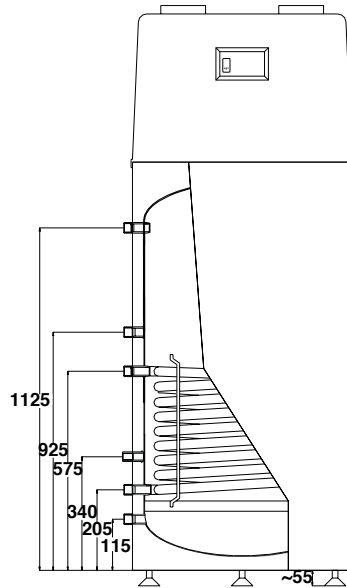



Download additional
content

 go.forinigroup.it/eng/content

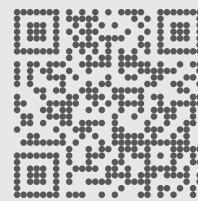

fiorini

Fiorini Industries S.r.l.
Ph. +39 0543 723197 – Fax +39 0543 720413
Via Zampeschi 119 – 47122 Forlì (FC) – Italy
www.fiorini-industries.com