



CONDENSERLESS WATER CHILLER  
FOR INDOOR INSTALLATION WITH  
REMOTE CONDENSER  
IT CAN BE COUPLED WITH REMOTE  
CONDENSER CLIVET SERIES CEM

# MDE-3

2.160-2.180-2.200-2.220-2.250-

2.280-2.300-2.320-2.340-2.360-2.390-2.420-2.450-

2.480-3.480-3.500-3.520-3.540-3.570-3.600-3.630

## RESIDUAL RISKS

### CONTENTS:

DEFINITION OF DANGEROUS AREA  
GENERAL RISKS  
REFRIGERANT SAFETY DIAGRAM

## WARNING

THIS SPECIFIC SECTION OF THE MANUAL POINTS OUT EACH OPERATION WHICH BRINGS WITH IT A POSSIBLE RISKY SITUATION AS WELL AS ALL THE PARTICULAR PRECAUTIONS TO OBSERVE.

### DEFINITION OF DANGEROUS AREA

The figure below points out the area which is accessible to authorised personnel only.

The **external dangerous zone** is a precise area all around the unit and its vertical projection on the ground in the case of hanging unit.

The **internal dangerous zone** is the area which one can enter only with previous and intentional removal of the protecting panels.

Figure 1

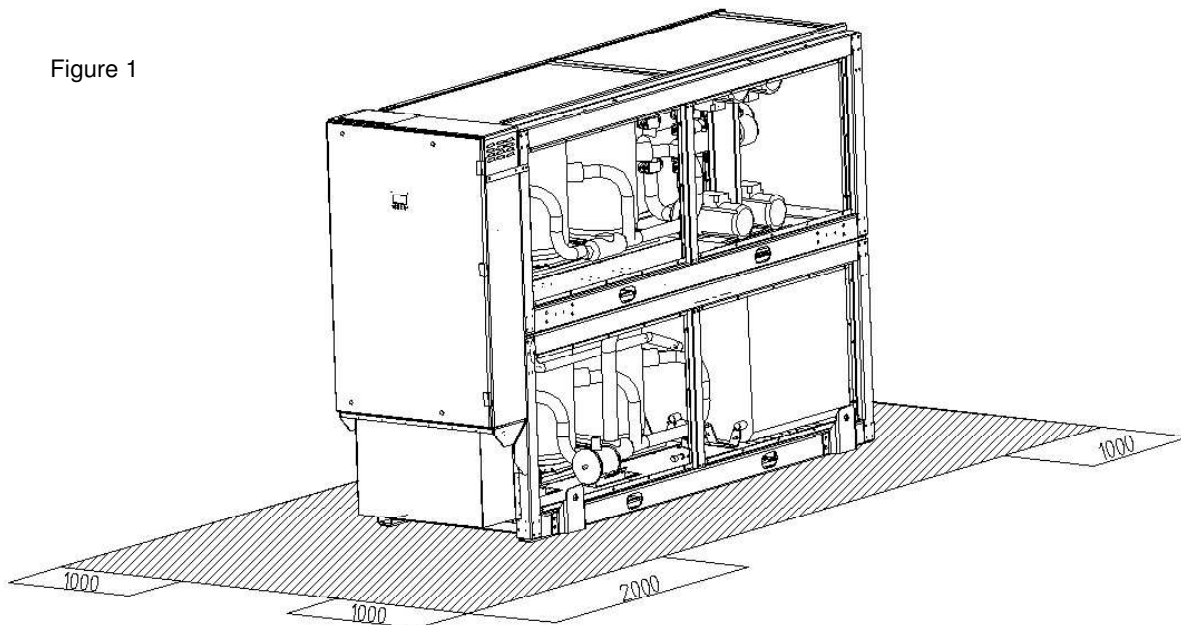

**Nota:** dimensions expressed in mm.

## GENERIC RISKS

Particular area	Danger	Modality	Instructions
Compressors	Burns	Contact	Avoid incidental contacts Wear protective gloves Apply compressor guards (optional).
Hot gas pipe	Burns	Contact	Avoid incidental contacts Wear protective gloves Apply compressor guards (optional).
LP safety valve	Wounds Intoxication	Refrigerant gas exhaust due to the intervention of the safety cut-out.	Avoid entering the dangerous zone Apply compressor guards (optional). Pipe in an appropriate way the safety exhaust valves Wear appropriate clothes and gloves.
Area surrounding the unit	Wounds Intoxication Serious burns Death	Explosion due to a rise in ambient temperature (fire).	Never shut the compressors inlet/outlet valves when the unit is off.
Area surrounding the unit	Death by: Serious burns Intoxication	Fire due to short-circuit or overheating of the power supply cables upstream of the unit mains switch.	Exact measurement of cables and safety cut-outs of the connections to the power supply line.
Unit internal part	Death by: Electrocution Serious burns	Defective insulation of the power supply cables upstream of the unit mains switch.	Enter the unit only after having opened the mains switch which connects the unit to the power supply line (customer's care)
Internal dangerous area	Death by: Electrocution	Contact with metallic components under tension.	Put scrupulously to earth the metal parts of the unit.
Internal dangerous area	Death by: Electrocution Serious burns	Contact with parts under tension which one can reach only after having removed the protective panels	Open the unit mains switch and lock it with a padlock before removing the panels.

## REFRIGERANT SAFETY DIAGRAM

01	Identifying elements for the substance	<b>Product name:</b> forane 134a N°SDS 00941 Supplier: ELF ATOCHEM ITALIA Via Degli Artigianelli 10, 20159 Milano tel. 02/668111
02	Information concerning composition of components	<b>Chemical name of the compound</b> 1.1.1.2 - tetrafloroethane <b>General name:</b> halogenated hydrocarbon CAS: 811-97-2 EINECS: 212-377-0
03	Identification of risk	<b>Effects on health:</b> practically non-toxic <b>Greatest physical and chemical dangers:</b> Thermal decomposition in toxic and corrosive products
04	First-aid measures	<b>Inhalation:</b> Carry the victim into the open air. Resort to oxygen or artificial respiration if necessary. <b>Contact with skin:</b> Frostbite must be treated in the same way as burns. <b>Contact with the eyes:</b> Immediate rinsing in abundant water. <b>Instructions for the physician:</b> Do not administer catecholamine (due to the sensitisation provoked by the product)
05	Fire prevention measures	<b>Specific dangers:</b> Thermal decomposition into toxic and corrosive products. Hydrofluoric acid. Hydrochloric acid in gaseous form. Phosgene Carbon monoxides (CO). <b>Specific means of intervention:</b> Cool containers/cisterns with jets of water. Prevent any sparks or flames. Do NOT smoke. <b>Special protection systems for fire-fighting squads:</b> Carry breathing apparatus and wear protective clothing.

06	Measures to take in case of accidental spillage	<b>Individual precautions:</b> Avoid contact with the skin, eyes and inhalation of vapours. In an enclosed space: ventilate or use breathing apparatus (risk of suffocation). NO SMOKING ALLOWED. Remove all risk of sparks or flames.
07	Manipulation and storage	<b>Manipulation:</b> <b>Technical measures/precautions.</b> Form of storage and manipulation applicable to the products: PRESSURIZED GAS. Ensure adequate ventilation and evacuation for the level of equipment. <b>Advice for use:</b> Prevent sparks and contact with hot surfaces. DO NOT SMOKE.. <b>Storage:</b> <b>Technical measures/Storage procedures:</b> Store at room temperature in the original container. Keep away from flames, hot surfaces and sparks. Store in a cool, well-ventilated place. Protect full containers from sources of heat to avoid excessive pressures. <b>Packing:</b> <b>Recommended:</b> Ordinary steel, Stainless steel. <b>Avoid:</b> Alloy containing more than 2% magnesium. Plastics.
08	Control of individual exposure/protection	<b>Precautionary measures to be taken:</b> Ensure a sufficient exchange of air and/or suction in workplaces. <b>Control parameters.</b> <b>Exposure limits:</b> recommended by ELF ATOCHEM: VME = 1000ppm=4420mg/m <sup>3</sup> <b>Individual protective equipment:</b> Respiratory protection: In case of insufficient ventilation, carry suitable breathing apparatus. Protection for the hands: Gloves Protection for the eyes: Protective eyewear. Specific hygiene measures: avoid contact with the skin, eyes and inhalation of the vapours. DO NOT SMOKE.
09	Physical and chemical properties	<b>Physical state (20°C):</b> liquid gas <b>Colour:</b> colourless <b>Smell:</b> Slightly similar to ether; pH: not applicable. <b>Boiling point/interval:</b> -26,4 °C <b>Melting point/interval:</b> -101 °C <b>Flash point:</b> No flare up at test conditions <b>Self-ignition temperature:</b> 743 °C (1bar) 215 °C (3bar) <b>Vapour pressure:</b> (25 °C):0.665MPa (6.65bar) a (50 °C):1.32MPa (13.2bar) a (70 °C): 2.12MPa (21.2bar) <b>Vapour density:</b> (25 °C): 4.26kg/m <sup>3</sup> <b>Density:</b> (25 °C): 1206kg/m <sup>3</sup> a (50 °C): 1102kg/m <sup>3</sup> a (70 °C): 996kg/m <sup>3</sup> <b>Solubility:</b> <b>water:</b> (25 °C): 0,9g/l <b>Distribution coefficient:</b> log Pow = 1.06 (n-octanole/water) <b>Other data:</b> Henry constant: 1.53Pa m <sup>3</sup> /mol Not dissociated in water Solubility of water in the product at 25 °C: 0,097% in weight. Critical temperature: Tc=101 °C Critical pressure. Pc=4.07MPa (40.7bar)
10	Stability and reactivity	<b>Conditions to avoid:</b> Avoid contact with flames and red-hot metal surfaces. <b>Dangerous decomposition products:</b> Thermal decomposition into toxic and corrosive products: hydrofluoric acid, hydrochloric acid in gaseous form, phosgene, carbon monoxide (CO) <b>Other information:</b> Stable product at ambient temperature. In presence of air the product can mix up into a flammable blend at particular temperature and pressure conditions.

11	Toxicological information	<p><b>Acute toxicity:</b>  <b>Inhalation:</b> Practically non-toxic in experiments conducted on animals.  CL50/inhalation/4 hrs/on rats&gt;500000ppm  As with other volatile aliphatic halogenated compounds, with the accumulation of vapours and/or the inhalation of large quantities, the product can cause: loss of consciousness and heart problems aggravated by stress and lack of oxygen; risk of death.</p> <p><b>Local effects:</b>  <b>Contact with skin:</b> Frostbite possible from splashes of liquefied gas.  Practically non-irritating for skin in experiments conducted on animals (rabbits).  <b>Contact with the eyes:</b> practically non-irritating for eyes in experiments conducted on animals (rabbits).</p> <p><b>Sensibilisation:</b>  <b>Contact with skin: Experimental for the animal:</b>  No skin sensitizer (guinea pig).  <b>Chronic toxicity:</b> Studies on animal protracted inhalation do not highlight any chronic toxic effect (rat/years(s)/ Inhalation: 50000ppm)  <b>Specific effects:</b> Genotoxicity according experimental available data NOT Genotoxic  <b>Cancerogenesis:</b> experiments on animals do not highlight carcinogen effect clearly demonstrated (rat /Inhalation – for oral administration)  <b>Toxicity for reproduction:</b> Foetal growth no toxic effect for foetal development (rat/rabbit/inhalation).  Fertility, according the available data on animal: no toxic effects on fertility (rats/inhalation)</p>
----	---------------------------	---

This document refers to the product as is and which conforms to the specifications supplied by ELF ATOCHEM. If combinations or mixtures are made, check that there are no new dangers resulting from this action. The information provided in this report has been provided in good faith and is based on our latest knowledge of the product in question as of the date of publication of the same. The attention of users is drawn to the potential risks of employing the product for any use other than that for which it is intended. This report must be used and reproduced solely for purposes of prevention and safety. The list of legislative, regulatory or administrative texts must not be considered exhaustive. The product user is under obligation to refer to all the official texts concerning the use, conservation and manipulation of the product for which he is sole responsible. The product user must also provide all those who might come into contact with the product with the information necessary for their safety at work and the protection of their health and that of the environment, giving them a copy of this safety information report.