

| MODIFIE PAR | IND | N. ETUDE | DATE | MODIFICATION |
|---|-----|----------|------|---|
|  | | | | |
| APPAREIL OU UNITE LSH.M 50Z MARKSA-AMADA | | | | MATIERE : |
| DESIGNATION ENCOMBREMENT | | | | EP : |
| NUMERO DE COMMANDE : | | | | TRAITEMENT |
| NOTE D'ETUDE : | | | | MASSE : |
| VERIFIE PAR : | | | | REPLACE PAR : |
| DESSIN PAR : P.BASTIAND | | | | REPLACE : |
| DATE: 09-Aug-00 | | | | ECHELLE 0.09 FOLIO FORMAT A3 |
| NUMERO DE PLAN 3986227 | | | | INDICE 00 |

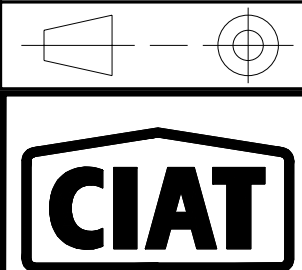
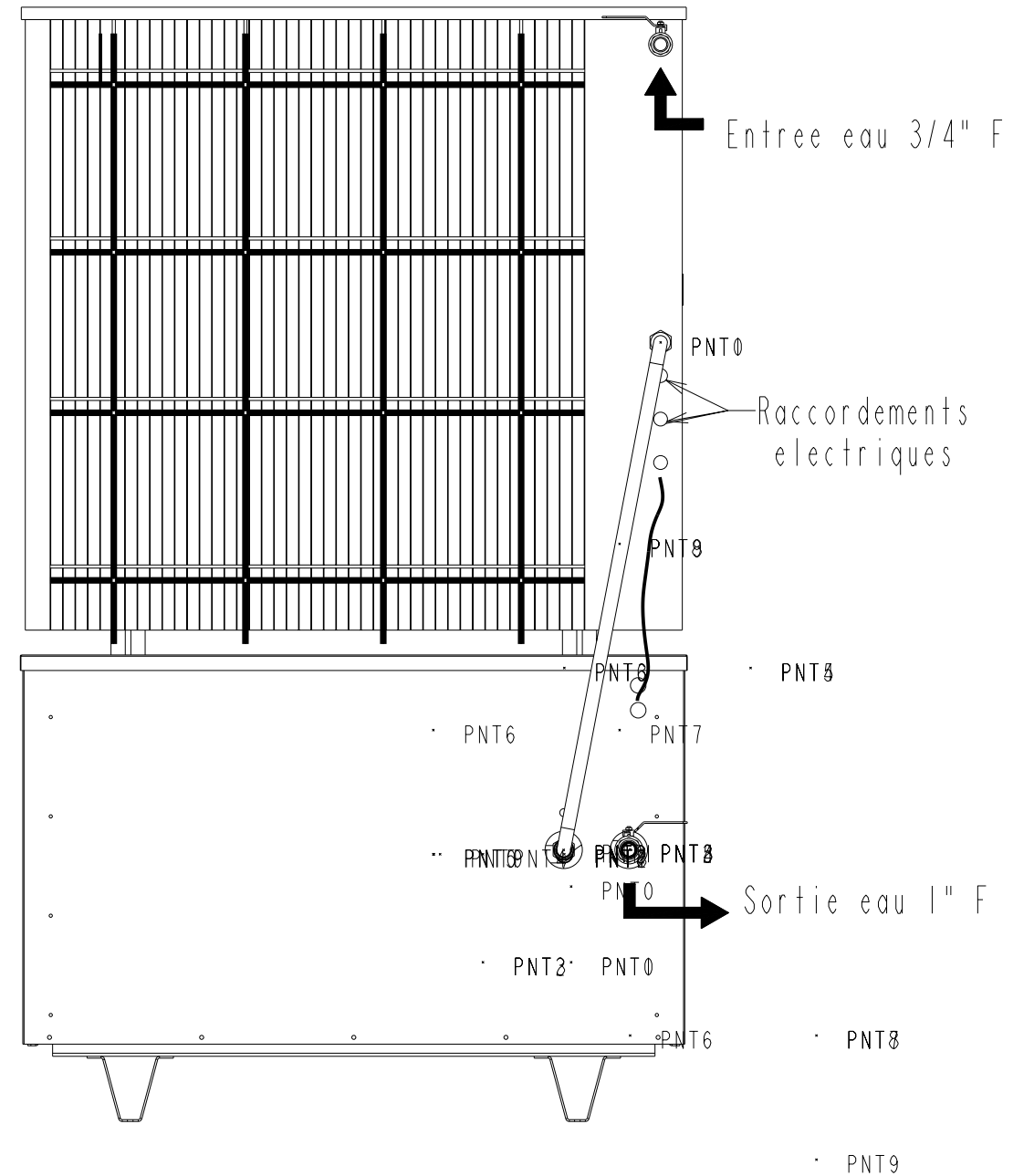
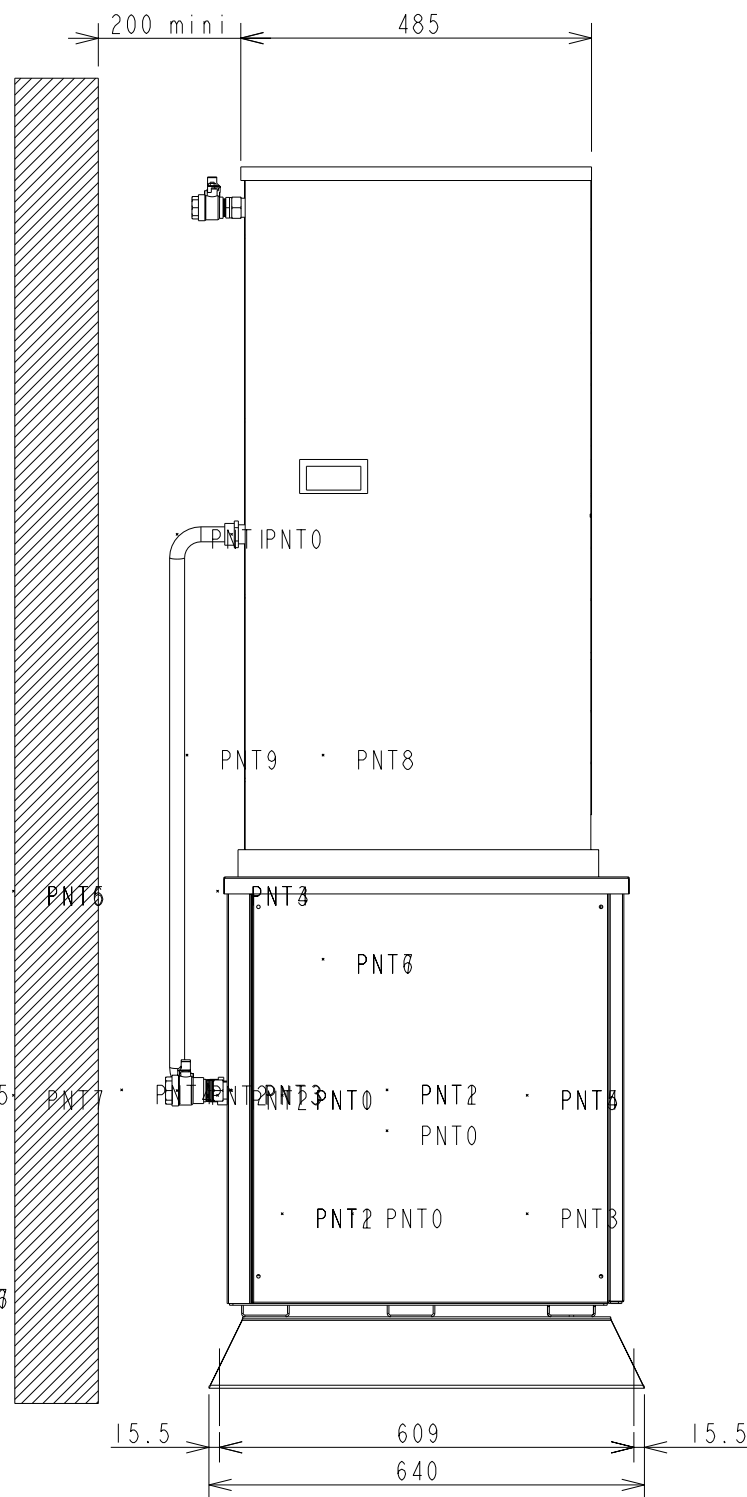
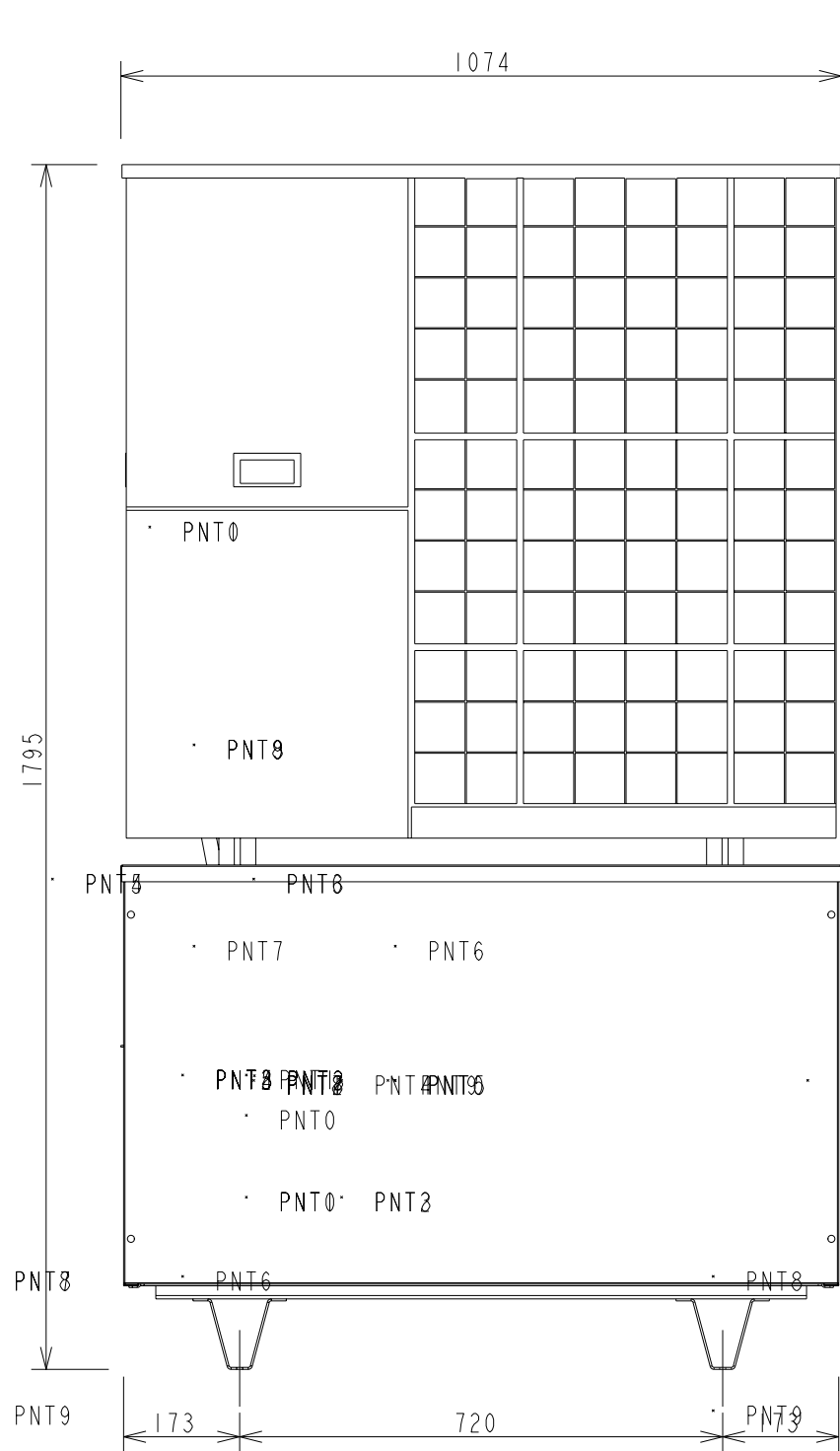
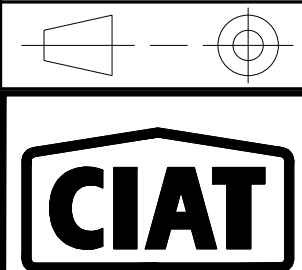

| MODIFIE PAR | IND | N. ETUDE | DATE | MODIFICATION |
|---|-----|----------|------|----------------------------------|
|  APPAREIL OU UNITE LSH.M 35Z 65Z MARKSA-DIXI | | | | |
| DESIGNATION ENCOMBREMENT | | | | |
| MATIERE : EP : | | | | |
| ECHELLE 0.09 | | | | |
| FOLIO TRAITEMENT MASSE : REMPLACE PAR : REMPLACE : | | | | |
| NUMERO DE COMMANDE : NOTE D'ETUDE : DATE : VERIFIE PAR : DATE : DESSIN PAR : P.BASTIAND DATE : 07-Sep-00 | | | | |
| FORMAT A3 | | | | NUMERO DE PLAN 3986230 |
| | | | | INDICE 00 |