

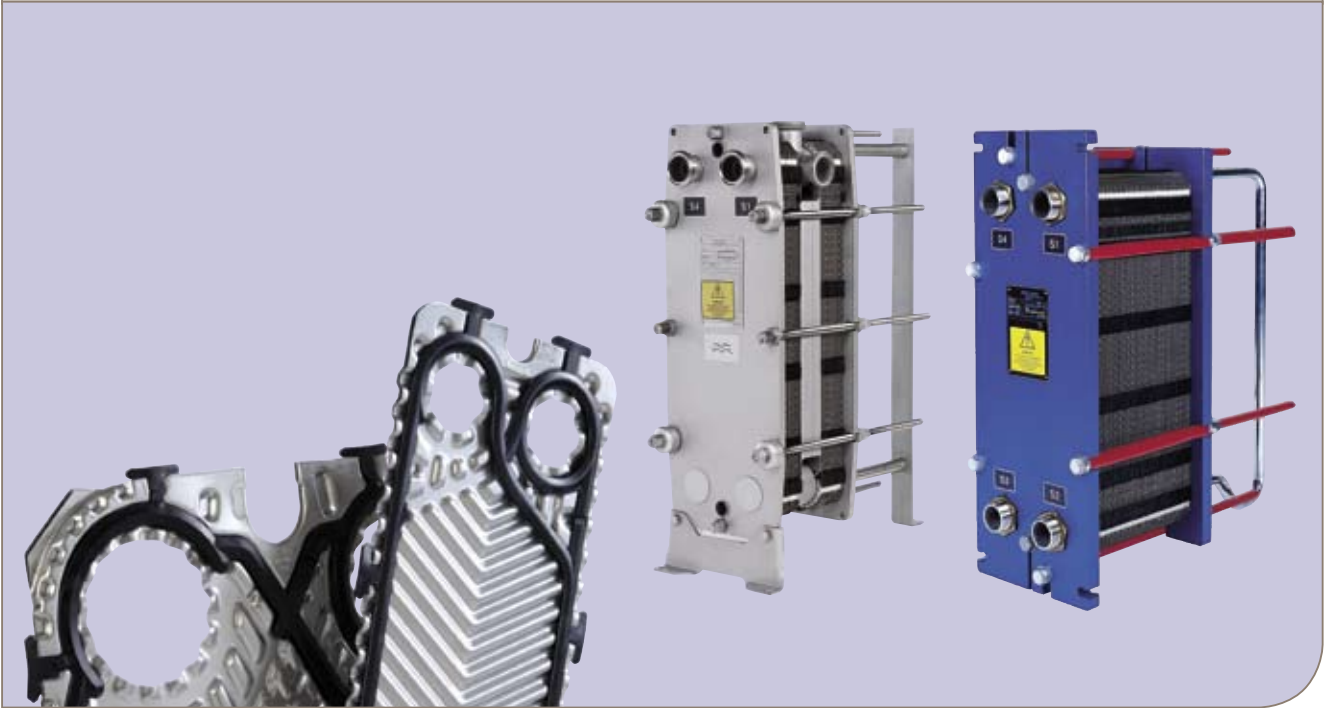

Cross-contamination safe double wall plates

M-Series/BaseLine Gemini Plate Heat Exchanger



Application

General cooling/heating for pharmaceutical, brewery and beverage applications when a mix-proof design is required. To secure the cross-contamination safe feature, water or water-like fluids is recommended.

Working principles

Channels are formed between the plates and the corner ports are arranged so that the two media flow through alternate channels. A unique distribution area provides an efficient flow over the plate surface. The heat is transferred through the plate between the channels, and complete counter-current flow is created for highest possible efficiency. The chevron corrugation of the plates provides the passage between the plates, supports each plate against the adjacent one and enhances the turbulence. The high turbulence resulting in efficient heat transfer and high surface shear forces to minimise fouling and the build-up of biofilm. The plates are reversible and have parallel flow, which means that only one type of gasket is needed.

Heat exchanger design

The plate heat exchanger consists of a pack of corrugated metal plates with portholes for the passage of the two fluids between which heat transfer will take place.

The plate pack is assembled between a fixed frame plate and a movable pressure plate and compressed by tightening bolts. The plates are fitted with a gasket, which seals the inter-plate channel and directs the fluids into alternate channels. The number of plates is determined by the flow rate, physical properties of the fluids, pressure drop and temperature program. The plate corrugations promote fluid turbulence and support the plates against differential pressure.

The plate and the pressure plate are suspended from an upper carrying bar and located by a lower guiding bar, both of which are fixed to a support column. Connections may be located in the frame plate and/or in the pressure plate.

Gemini plates

The Gemini plates consist of two plates with a small air gap in between. Contact to the atmosphere is safeguarded around the whole periphery of the plates. The Gemini double wall plates will give a cross-contamination safe design, as a crack in a plate will not result in mixing of the two media.

Gasket

The Gemini plate heat exchangers are supplied with our standard glue-free ClipOn gaskets of a double-gasket design. The double-gasket design has two sealing surfaces between the product and the cooling/heating media. This ensures that no intermixing will occur if one of the gaskets should leak. Instead the leakage will drain to a chamber and then out to the atmosphere.

FRAME

The Gemini plate heat exchanger is available in either the M-series or the BaseLine frame.

M-Series frame – This is our standard frame where the frame plate material is epoxy painted mild steel. The frame is available with optional lining in various materials.

BaseLine frame – The BaseLine frame is a solid stainless steel frame with fixed or adjustable feet. The tightening bolts are equipped with ball bearing washers in order to facilitate easy opening and closing of the unit. The M6-MGBase is also available with connection plates which give the possibility to have several heat exchangers in one frame unit.

TECHNICAL SPECIFICATIONS

PLATE MATERIAL

Stainless steel AISI 316. Surface finish $Ra < 0,3 \mu m$ (in the cold formed area $Ra < 0,8 \mu m$)

GASKET MATERIAL

EPDM (FDA compliance and USP Class VI), Nitrile (FDA compliance).

CONNECTIONS

Clamp, DIN, ISO, SMS, B.S., Flanges, others on request.

MECHANICAL DESIGN PRESSURE/TEMPERATURE

10 barg / 160 °C (145 psig / 320 °F) (depending on gasket material).

PRESSURE VESSEL CODES

M-series

PED and ASME

BaseLine

PED

OPTIONS

- A. 3.1 according to EN 10204
- B. Plates in 316L
- C. Electro-polishing
- D. Pressure test certificate
- E. Protection sheet
- F. Adjustable feet

All options are not available on all models

Measurements mm (inch)

Dimensions	M3-G		M6-MG	
	M-Series	BaseLine	M-Series	BaseLine
B	180 (7.1)	180 (7.1)	320 (12.6)	304 (12)
C	60 (2.4)	60 (2.4)	140 (5.5)	140 (5.5)
D	357 (14.1)	357 (14.1)	640 (25.2)	640 (25.2)
E	480 (18.9)	545 (21.5)	920 (36.2)	920 (36.2)
F	61.5 (2.4)	141 (5.6)*	140 (5.5)	181 (7.1)*
G		176 (6.9)		290 (11.4)
H	550 (21.6)	250-510 (9.8-20.1)	515-1635 (20.3-64.4)	575-1925 (22.6-75.8)
Connection ø mm	32 (1.3)	25 (1)	50 (2)	50 (2)
Unpressed plate thickness	0.50 + 0.25 (0.02 + 0.01)		2 x 0.4 (0.08 - 0.02)	

* Measurement for fixed feet. Adjustable feet are also available.

Dimensions

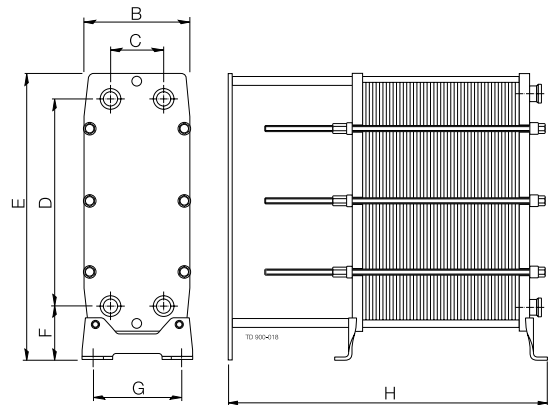

How to contact Alfa Laval

Up-to-date Alfa Laval contact details for all countries are always available on our website at www.alfalaval.com