



LOT6

2018

ec

technology



aeroefficiency

ETALINE

SETS THE STANDARD IN EFFICIENCY SINCE 2007

THE PROVEN SOLUTION

The ETALINE series was developed in 2007 and has since set standards in terms of efficiency and energy saving potential. The goal from the start was to develop a fan that meets most of the pressure, flow and energy efficiency needs. Designed before the Ecodesign Directive was passed, all ETALINE series exceed the current requirements.

Built on the diagonal fan principle, the blades of the impeller and the downstream stator are three-dimensionally curved. This causes the conversion of the dynamic pressure at the impeller outlet into usable static pressure.

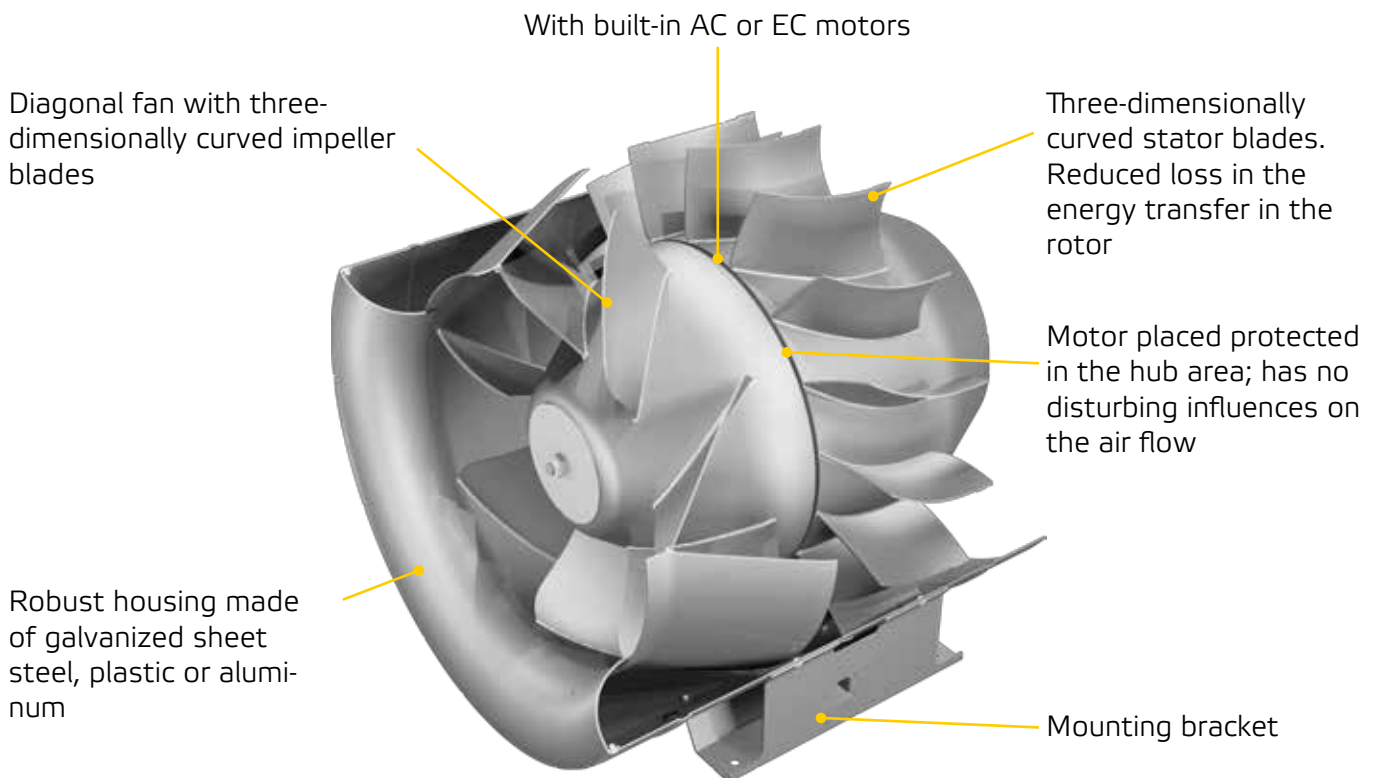

ETALINE - The design

A COMPLETE RANGE



ETALINE...EC

- EC motors with high efficiency over the entire performance curve
- Plastic or aluminum housing
- Stepless control via 0-10V signal



ETALINE...D

- Robust, three-phase AC motors
- Housing made of galvanized sheet steel or aluminum
- Control via frequency converter

MAXIMUM AIR PERFORMANCE CURVES

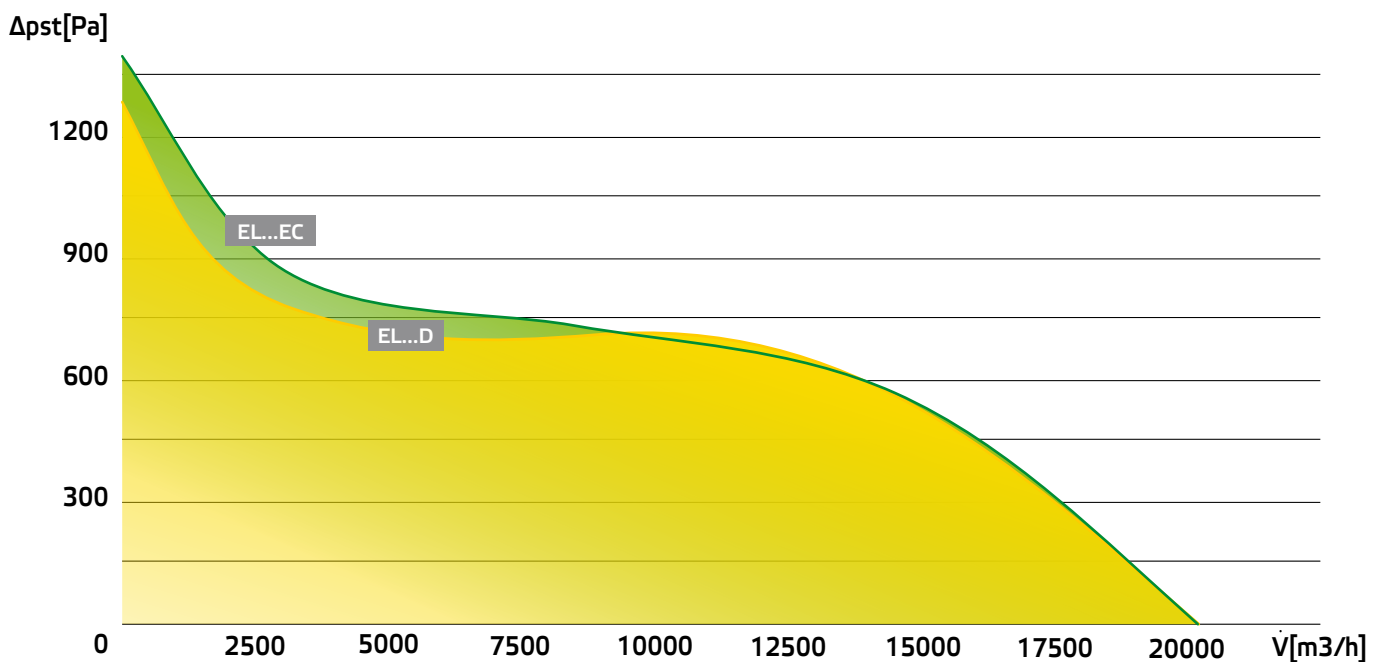

FOR VERSATILE APPLICATIONS



ETALINE...E

- Single phase AC motors
- Housing made of galvanized sheet steel, plastic or aluminum
- Voltage controllable by means of step transformer



ETALINE...M

- 3-speed AC motors
- Housing made of galvanized sheet steel or plastic
- Controllable with the MTS 3-step switch

MAXIMUM AIR PERFORMANCE CURVES

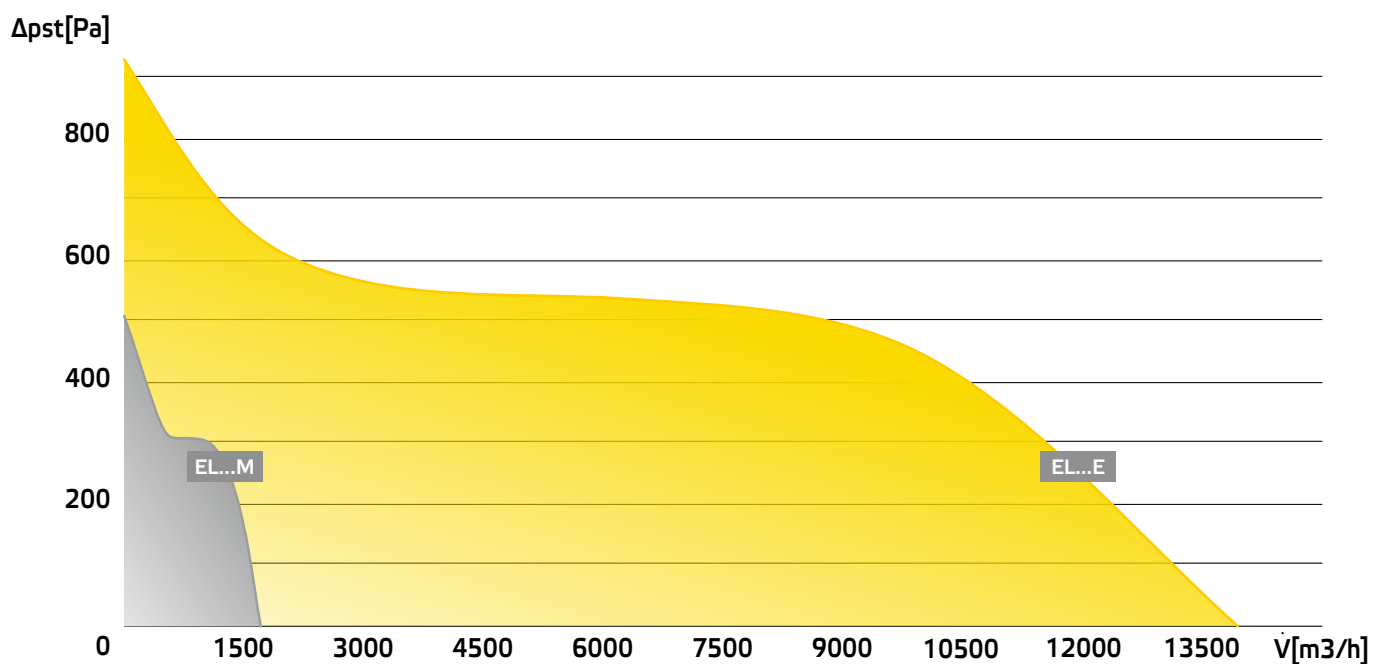

DEMAND-ADJUSTED PROGRAM

ETALINE can be integrated directly into the duct system. Since the housing is only slightly larger than the pipe system, there are almost no additional space requirements. The mounting bracket is integrated as standard. We recommend connecting the pipes via sound decoupling VM fast clamps.

For the EC motors, further control options such as CO₂, humidity or external volume flow control are possible.

All motors have integrated motor protection.

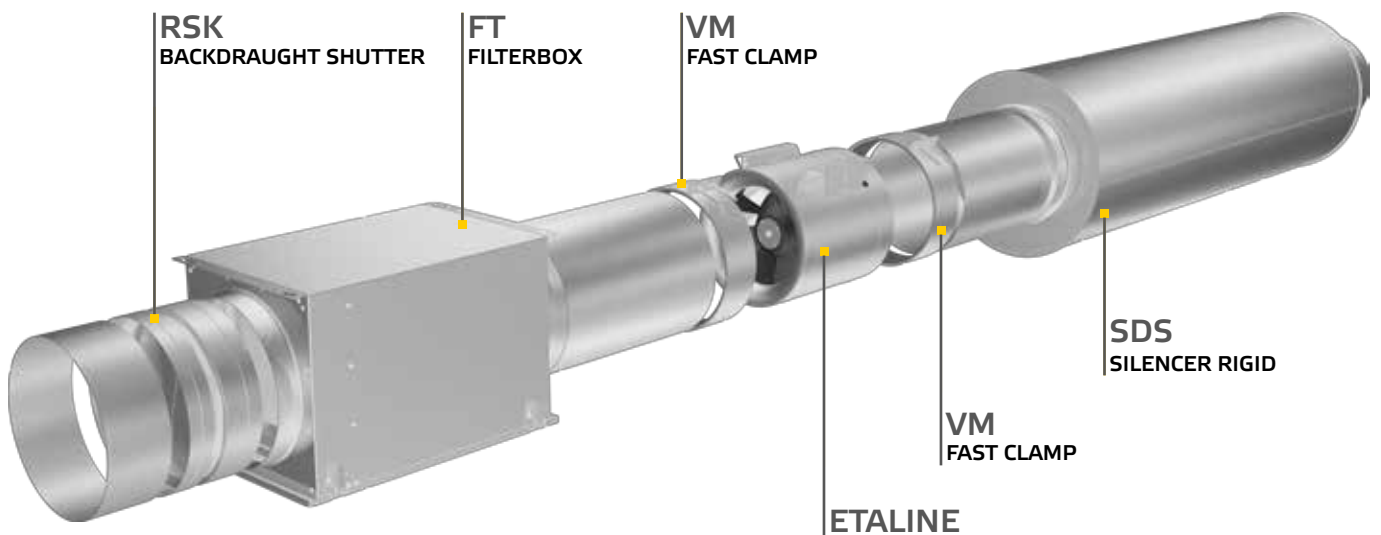

MECHANICAL ACCESSORIES



ELECTRICAL ACCESSORIES



* For EL...EC

OUR PRODUCT PORTFOLIO

IN LINE TUBE FANS

ETALINE and ETAMASTER, the No. 1 in saving energy.



DUCT FANS

Backward curved centrifugal fans, sound insulated, compact diagonal fans.



EXHAUST FANS

Exhaust fans for industry and kitchen exhaust, up to 200 °C continuous operation, 400 °C / 120 min.

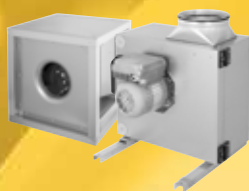

ROOF FANS

Roof fans with horizontal and vertical discharge, up to 200 °C continuous operation, 400 °C / 120 min.



COMPACT AHU

With counter flow heat exchanger with more than 90% heat recovery efficiency and EC fans. Available with horizontal or vertical air guidance respectively flat units for suspended ceiling mounting.



COMPACT AHU

With rotary heat exchanger with up to 80% heat recovery efficiency and EC fans. Available with horizontal or vertical air guidance.



ruck Ventilatoren GmbH

Max-Planck-Str. 5
D-97944 Boxberg

Tel. +49 (0)7930 9211-300
Fax +49 (0)7930 9211-166

www.ruck.eu
info@ruck.eu

