



Ecocirc[®] D5solar DC pump

THE MULTI-AWARDED DC SPHERICAL MOTOR PUMP FOR
DIRECT CONNECTION TO PHOTOVOLTAIC PANELS

Ecocirc[®] D5solar design

Stator with high efficiency technology,
integrated MPP Tracking,
overtemperature protection and soft start-up

Screw ring

Ceramic bearing ball

Gasket

Permanent magnetic
rotor/impeller unit

**PumpIndustry
Awards 2009**

**h&v news
AWARDS
2007**

Soft start at very low insolation (soft start
algorithm, less than 1 Watt required)

Economical and powerful

Long life, blockage free and maintenance
free

RF suppressed

Protection against reverse polarity

Design.

The principle of the spherical motor is fundamentally different from conventional canned motor pumps. The only moving part in a spherical motor is a hemispherical rotor/impeller unit, which sits on an ultra-hard, wear-resistant ceramic ball.

There are no conventional shaft bearings or seals. This rules out, in effect, the possibility of play in the bearings and the increase in noise associated with it. These pumps are particularly robust and give exceptionally long service. The self-realigning bearing is lubricated and cooled by the media. Maintenance is not necessary under normal conditions and even after lengthy shutdown periods a reliable start-up is virtually guaranteed. The parts exposed to the fluid are completely corrosion resistant.



Pump housing

Application.

The Ecocirc solar pump can be used wherever a highly efficient circulation pump is needed without a direct connection to AC power. It can be connected directly to a photovoltaic panel and is characterized by its small size, high efficiency, very low power consumption and its MPP tracking. The shaftless spherical motor technology enables a long, maintenance free and quiet service life. Areas of application are thermal solar systems for single family homes.

Soft start-up.

The pump has been programmed for a soft start-up. When the photovoltaic panel provides sufficient power, the pump first goes through the alignment phase, turning the rotor into the position required for start-up. Then the processor waits until the built-in capacitor has recharged sufficiently. This enables a start-up with minimal power (less than one Watt). Cycling due to unsuccessful starting attempts is minimized. Even after prolonged shutdown, the pump will start reliably.

Integrated overtemperature protection.

The pump comes with an integrated overtemperature safety device, which shuts the pump electronics off when reaching overtemperature. Normally the temperature of the pumped media during operation at the highest speed setting is 95°C at this point.

A complete shutdown after reaching overtemperature conditions can result in adverse effects on the circulating system. Since the temperature of the electronic components is influenced by the temperature of the pumped media as well as by the speed setting, the pump will lower its speed automatically after reaching a critical temperature level in order to avoid a total shutdown. However, if the temperature continues to rise (caused e.g. by too hot pumped media), the pump will eventually shut down completely. After cooling down, the pump will restart automatically.

Technical Data.

Motor design	Electronically commutated spherical motor with permanent magnet rotor/impeller
Voltage	8 - 24 Volt
Power consumption*	- min. start-up power consumption less than 1 Watt, - max. power consumption 22 W
Current draw	0,25 - 1,46 A
Acceptable media	domestic hot water, heating water, water/glycol mixtures, other media on request**.
Insulation class	IP 42 / Class F

Pump housing material	Brass	Noryl
Max. system pressure	1 Mpa (10 bar)	0,15 MPa (1,5 bar)
Max. system temp.***	-10 to + 95°C	+/- 0 to + 60°C
Weight	0,7 kg	0,35 kg

* Power consumption and start may vary in different installations
 **please check pump performance with more than 20% glycol
 *** non-freezing, non condensing



Model designation.

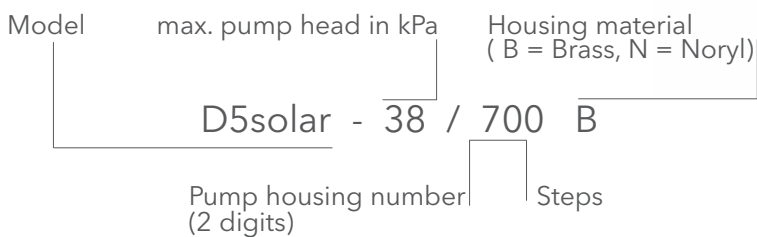

Automatic performance optimization

Maximum Power Point Tracking.

The Laing Ecocirc D5solar is the first and only spherical motor pump with self-optimizing software (see diagram). Every three seconds, the processor will modify its operating point on the voltage-current curve of the PV panel to find the point of maximum performance. This is called the "Maximum Power Point" (MPP).

At this point, the pump achieves the maximum rpm and therefore the maximum performance.
There is no need for a separate performance adaptation. The pump will always find its best operating point under any given light and temperature conditions by itself.

MPP-Tracking.

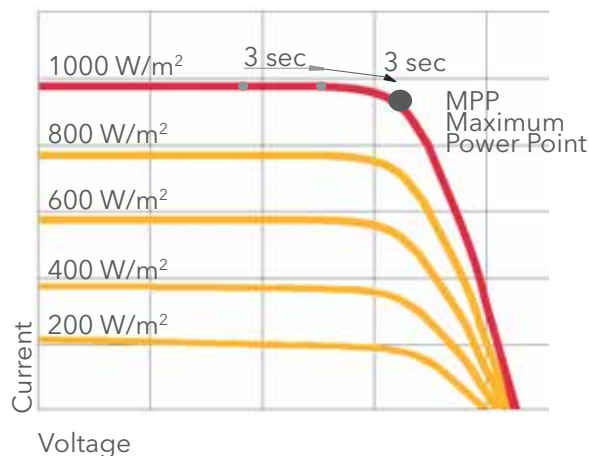

Typical Current-Voltage-curve of a photovoltaic panel.

By employing MPP tracking every three seconds, the Ecocirc D5solar pumps always automatically achieve maximum performance at any given insolation.

Product range.

Highly efficient DC pump with ECM-technology and permanent magnetic rotor, MPP-Tracking, soft start at very low insolation (soft start algorithm, less than 1 Watt required), integrated over-temperature protection, 8-24 Volt (driven by a 12 Volt panel; if driven by a 24 Volt panel a maximum voltage limitation to 24 V is required), max. input 22 Watt, 0,25 - 1,46 A current consumption, isolation IP 42 / Class F.



Model	Part number	Pump housing	max. system temperature	Housing design and length	Connection	Product category
D5solar-38/700 B	LH 60 00 403	Brass	95° C	Inline / 65 mm	1/2" female thread	7 K
D5solar-38/100 B	LH 60 00 413	Brass	95° C	Inline / 110 mm / RV+KH*	1 1/4" male thread**	

* integrated check valve and ball valve; ** for connection to 3/4" union components. Housing has additionally a 1/2" female connection

Accessories, components and spare parts.

Model	Part number	Description	Product category
RV 1/2"	LH 95 00 001	Brass check valve 1/2" male thread x 1/2" female thread	7 K
KH 1/2"	LH 95 00 020	Chrome plated brass ball valve 1/2" male thread x 1/2" female thread	
AV 1/2" x 1/2"	LH 95 00 024	2 pieces brass union fitting 1/2" male thread x 1/2" female thread	7 K
AV 5/4" x 3/4"	LH 95 00 025	2 pieces brass union fitting 1 1/4" female thread x 3/4" female thread	
MW C	LH 95 00 041	Mounting plate for D5solar pumps	

Pump curves and dimensional drawings.

Dimensional drawings in mm, pump curves at 12 Volt, min. start-up power consumption less than 1 Watt (12 Volt panel), max. power consumption approx. 22 Watts.

D5solar-38/700 B

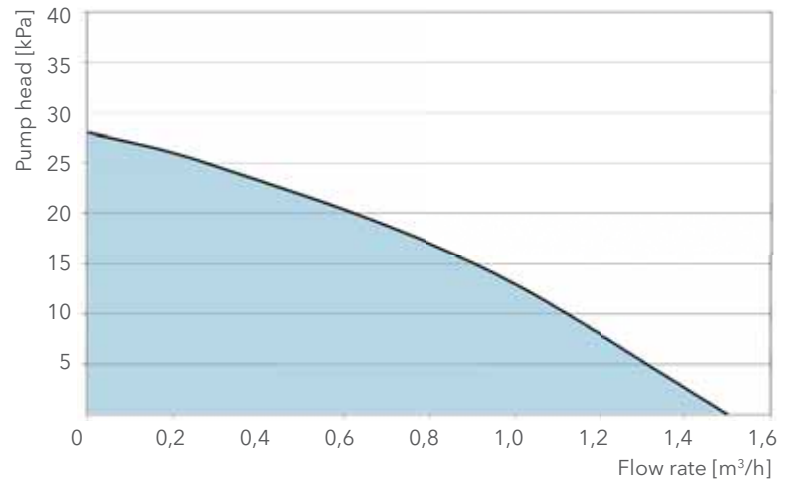
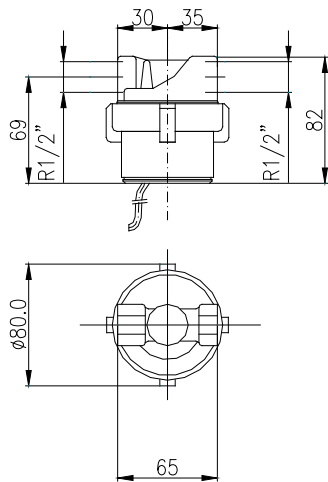

D5solar-38/100 B

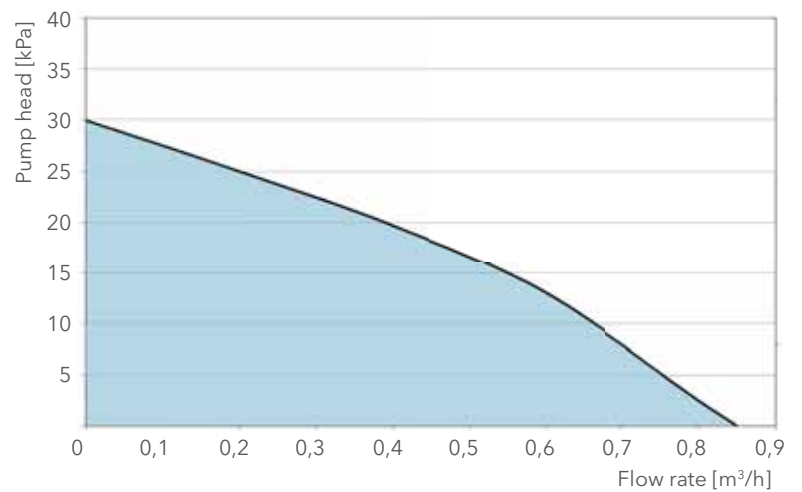
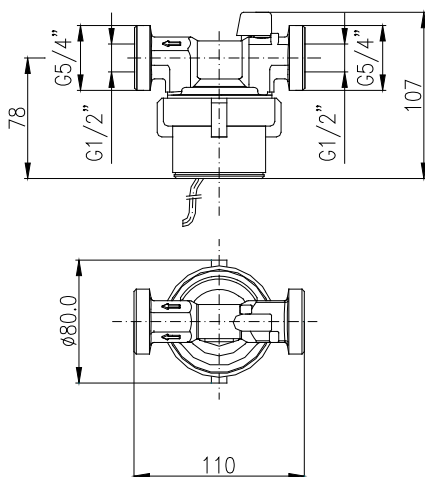

What can Xylem do for you?

Xylem ['zɪləm]

- 1) The tissue in plants that brings water upward from the roots;
- 2) a leading global water technology company.

We're 12,000 people unified in a common purpose: creating innovative solutions to meet our world's water needs. Developing new technologies that will improve the way water is used, conserved, and re-used in the future is central to our work. We move, treat, analyze, and return water to the environment, and we help people use water efficiently, in their homes, buildings, factories and farms. In more than 150 countries, we have strong, long-standing relationships with customers who know us for our powerful combination of leading product brands and applications expertise, backed by a legacy of innovation.

For more information on how Xylem can help you, go to xylem.com.



LOWARA S.r.l. Unipersonale
Via Vittorio Lombardi, 14
36075 Montecchio Maggiore
Vicenza - Italy
Tel. (+39) 0444 707111
Fax (+39) 0444 492166
e-mail: lowara.mkt@xylem.com
www.lowara.com
www.completewatersystems.com

Lowara is a trademark of Xylem Inc. or one of its subsidiaries.