

Cooling capacity : 16,8 to 19,8 kW

**The air conditioning solution
when outdoor
location is not possible**



CENTRIFUGAL
CONDENSER

USE

These units, designed for industrial and air conditioning applications, benefit from the last technological developments and are equipped with performing components

Monobloc units designed for internal location in a plant room.

Each unit is entirely assembled, electrically wired, with refrigerant connections, charged in refrigerant and tested in factory.

■ **2 models : 65, 75**

1 compressor, 1 refrigerant circuit

All the units are conform to the "CE" directives (Machines and CEM)

QUICK SELECTION

CIATCOOLER LJ

Size	Number of circuits	Number of compressors	Cooling capacity	Cooling capacity
65	1	1	17,1	6,3
75	1	1	20,3	7,2

DESCRIPTION

The **CIATCOOLER series LJ** standard is delivered with :

- Hermetic compressor
- Centrifugal fan, air cooled condenser
- Brazed plates evaporator
- Summer operation (up to + 12 °C ext.)
- Electrical power and control panel
- Electrical supply : 400 V $\pm 6\%$ - 3 ph - 50 Hz + neutral

For other electrical supplies, consult us.

- Anti-corrosion casing, in galvanized metal covered with structured lacquer with a polyester and varnish basis
- Survey and control **electronic module**, with **MRS1-2.1. microprocessor**

■ Hermetic compressor

- Alternative, reciprocating
- Internal protection of motor windings
- Crankcase heater
- Mounting on antivibratil mounts

■ Evaporator

- Brazed plates type
- End plates and internal plates in stainless steel AISI 316
- High performance optimized plates profile
- Thermal insulation

■ Air cooled condenser

- Coil with copper tubes/aluminium fins
- 1 centrifugal fan with pulleys and belts drive
- Available pressure from 0 to 15 mmwg
- Sealed motor IP 55 Class F
- Vertical discharge

OPTIONS

■ Supply voltage

- 230 V - 3 ph - 50 Hz + Earth.
(Standardized voltage in France)

■ Oil bath pressure gauges

- 1 high pressure gauge
- 1 low pressure gauge

■ Remote control

This box, delivered separately, permits a remote control of the unit (3000 meters) :

- Modification of the setting point
- Visualization by LEDs of the operating status
- Run/Stop, Heating / cooling, Setting L / 2 keys
- Synthesis fault display light.
- Lamps test
- Display of water temperature
- Setting points control
- Liaison between the remote control card and the MRS1 electronic module by 2 wires only.

■ Standard accessories

- Filter dryers
- Liquid sight glass
- Thermostatic expansion valve
- Discharge muffler

■ Electrical panel

- Output circuit protection
- Control circuit protection
- Compressor motor contactor
- Fan motor contactor
- Main earth protection
- Wire numbering
- 4 pole safety switch

– **Microprocessor MRS 1 electronic module** ensuring the following main functions :

- . Chilled water temperature control
- . Operating parameters control
- . Second set point control
- . Chilled water temperature display
- . Faults diagnosis : HP, LP; water flow; compressor motor; antifreeze
- . Counting of the compressor operating time
- . Anti-short cycling
- . Remote control and survey (see specific brochure MRS 162.1.)
- . Pack conform to European norm CEI 204

■ Regulation and safety panels

- High and low pressure safety pressostats
- Water flow controller
- Antifrost sensor
- Chilled water sensor
- Capacity control

■ Relay card

This card, delivered separately, permits remote visualization of faults as well as operating status of the regulation stages (dry contacts exit). Liaison between the relay card and the **MRS 1 electronic module** by 2 wires only.

■ Flexible connections kit

■ Antivibratil mounts

■ Fan intake canvas sleeve

■ Fan discharge canvas sleeve

■ All year round operation

- Valid down to – 15 °C external temperature, this device ensures the condensing pressure control through :
 - A damper box
 - A pressostatic control jack

■ Intake filter kit

OPERATING LIMITS

■ Condenser

Air inlet temperature to the condenser :
 – Mini °C – 15
 – Maxi °C + 44

■ Evaporator

The curves below represent the minimum and maximum allowable temperature difference of the glycol or chilled water as a function of the outlet temperature.

- 30 % concentration of glycol weight
- Freezing point of the solution : –17,5 °C.

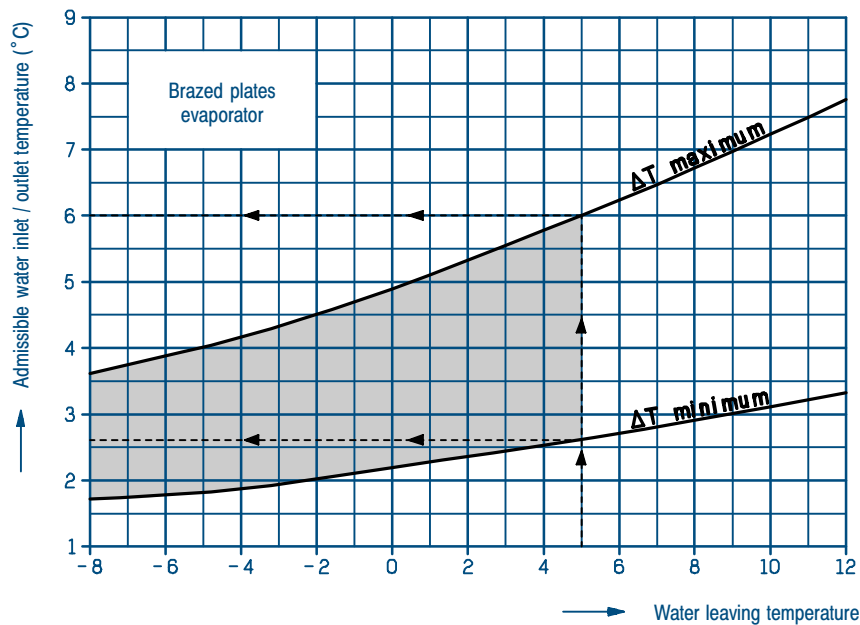

Example :

For a water outlet temp. : + 5 °C

ΔT minimum : 2,6 °C

Water temp. : 7,6 / 5 °C

ΔT maximum : 6 °C

Water temp. : 11 / 5 °C

For temperature differences not included in this chart, consult us.

WATER GLYCOL COEFFICIENTS

- 30 % Concentration of glycol weight
- Freezing point of the solution : –17,5 °C.

CORRECTION			POSITIVE TEMPERATURE	NEGATIVE TEMPERATURE
Evaporator	Cooling capacity	E1	0.98	See selection table
	Chilled water flow	E2	1.05	1.10
	Pressure drop	E3	1.15	1.30
	Average temperatures	°C	12/7	See table above

COOLING CAPACITIES

CENTRIFUGAL CONDENSER

LJ	Chilled water leaving temperature °C	CONDENSER ENTERING AIR TEMPERATURE IN °C												
		29		32		35		38		40		44		
		Pf Kw	Pa Kw	Pf Kw	Pa Kw	Pf Kw	Pa Kw	Pf Kw	Pa Kw	Pf Kw	Pa Kw	Pf Kw	Pa Kw	
65	Glycol water	-8	10.0	4.60	9.5	4.80	9.0	5.10	8.5	5.30	8.2	5.40	7.6	5.60
		-6	11.0	4.85	10.5	5.00	10.0	5.30	9.5	5.50	9.2	5.60	8.6	5.80
		-4	12.0	5.10	11.5	5.20	11.0	5.50	10.5	5.70	10.2	5.80	9.6	6.00
		-2	13.0	5.35	12.5	5.40	12.0	5.0	11.5	5.90	11.2	6.00	10.6	6.20
		0	14.0	5.60	13.6	5.70	13.1	5.90	12.5	6.10	12.2	6.20	11.6	6.40
		2	15.0	5.85	14.6	5.90	14.2	6.10	13.6	6.30	13.3	6.40	12.6	6.60
	Pure water	5	16.4	6.00	16.0	6.10	15.7	6.30	15.0	6.50	14.6	6.60	13.9	7.00
		6	16.9	6.10	16.5	6.20	16.2	6.40	15.7	6.60	15.2	6.70	14.3	7.10
		7	17.4	6.20	17.1	6.30	16.8	6.50	16.1	6.70	15.6	6.80	14.7	7.20
		8	18.0	6.30	18.7	6.40	17.4	6.60	16.7	6.80	16.2	6.90	15.3	7.30
		10	19.2	6.40	18.9	6.50	18.5	6.75	17.8	6.90	17.3	7.00	16.5	7.50
		12	20.4	6.60	20.0	6.70	19.6	6.90	19.0	7.10	18.6	7.20	17.8	7.60
75	Glycol water	-8	11.8	5.40	11.3	5.50	10.8	5.70	10.1	5.75	9.6	5.80	8.8	5.90
		-6	13.0	5.60	12.5	5.70	12.0	5.90	11.3	6.00	10.8	6.10	9.9	6.15
		-4	14.2	5.80	13.7	5.90	13.2	6.10	12.1	6.20	11.4	6.30	10.0	6.40
		-2	15.4	6.00	14.9	6.10	14.4	6.30	13.3	6.40	12.6	6.50	11.1	6.65
		0	16.6	6.20	16.1	6.30	15.6	6.50	14.5	6.70	13.7	6.80	12.2	6.90
		2	17.8	6.40	17.3	6.50	16.8	6.70	15.7	6.90	14.8	7.00	13.3	7.20
	Pure water	5	19.6	6.80	19.1	7.00	18.6	7.20	17.7	7.40	17.1	7.50	16.0	7.60
		6	20.2	6.90	19.7	7.10	19.2	7.30	18.3	7.50	17.7	7.60	16.6	7.80
		7	20.8	7.00	20.3	7.20	19.8	7.40	18.9	7.60	18.3	7.70	17.1	7.90
		8	21.6	7.05	21.0	7.30	20.5	7.50	19.4	7.70	18.8	7.80	17.9	8.00
		10	23.3	7.15	22.6	7.40	22.0	7.60	21.1	7.80	20.5	7.90	19.4	8.25
		12	25.0	7.20	24.2	7.50	23.4	7.70	22.6	7.95	22.1	8.10	21.0	8.50

Pf : Cooling output valid for a ΔT according to the operating limits
Pa : Power absorbed by the compressors only

Use of water glycol os obligatory.

WATER PRESSURE DROP

In the evaporator

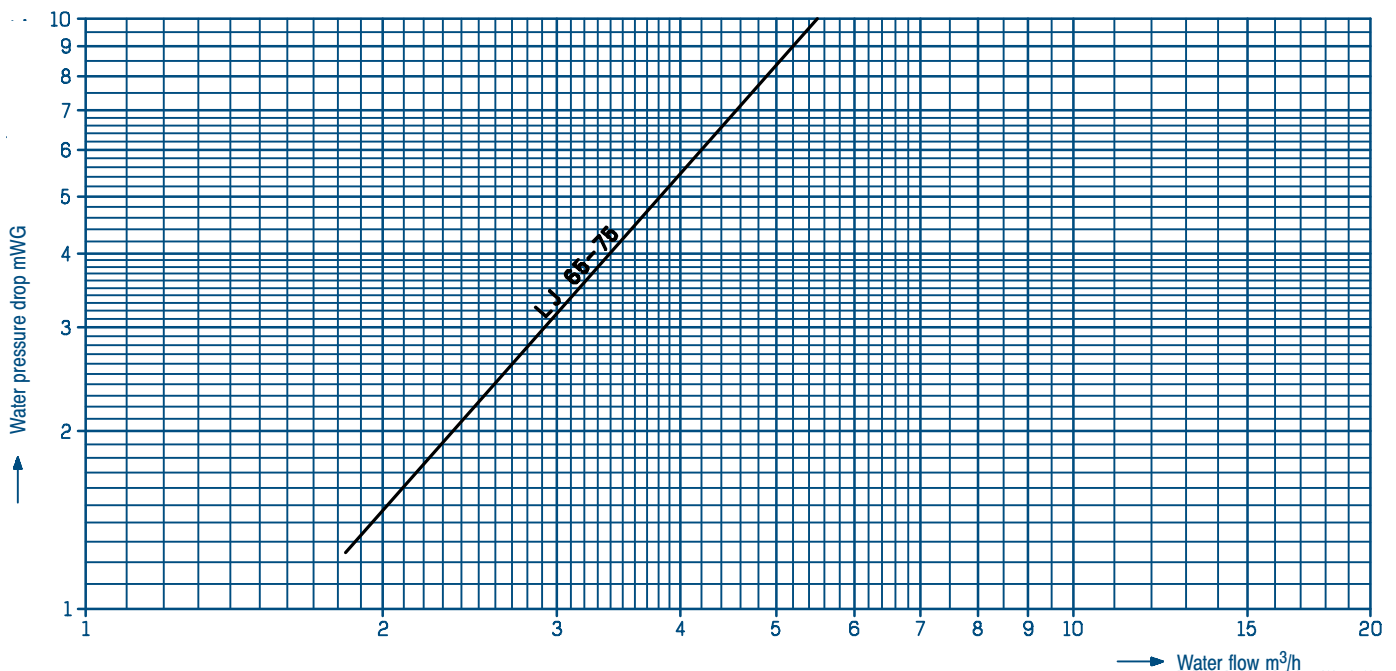



Chilled water production units

ciatcooler

CENTRIFUGAL
CONDENSER

CENTRIFUGAL FANS ROTATION SPEED IN RPM

LJ		65	75
Flow	m ³ /h	7000	7000
	10	692	692
Available static pressure	15	760	760
	20	832	832
	25	894	894

TECHNICAL CHARACTERISTICS

LJ		65	75
Compressor	Number	1	
	Type	Hermetic, propeller type	
	Rotation speed	rpm 2900	
	Refrigerant fluid	R 22	
Capacity control	%	100-0	
Evaporator	Number	1	
	Type	Brazen plates	
	Water content	L 1,7	
Air cooled condenser	Number	1	
	Type of fans	Centrifugal - Belts and pulleys drive	
	Number/power motor	kW 1 / 1.5	
	Total air flow	m ³ /h 7000	
	Available static pressure	mmCE 10	
	Rotation speed	rpm 700	

ELECTRICAL CHARACTERISTICS

LJ			65	75
COMPRESSOR				
Nominal current (1)	A	230 V*	27,2	29
		400 V	14,2	17
FAN MOTOR				
Nominal current (1)	A	230 V*	5.4	5.4
		400 V	3.1	3.1
COMPRESSOR + FAN MOTOR				
Max. nominal current	A	230 V*	32,6	31,4
		400 V	17,4	20,1

* Standard voltage in FRANCE.

(1) Max. intensity based on a + 12.5°C intake temperature and a + 65 °C condensation temperature (intensity obtained on units working under nominal voltage)

DIMENSIONS

CENTRIFUGAL
CONDENSER

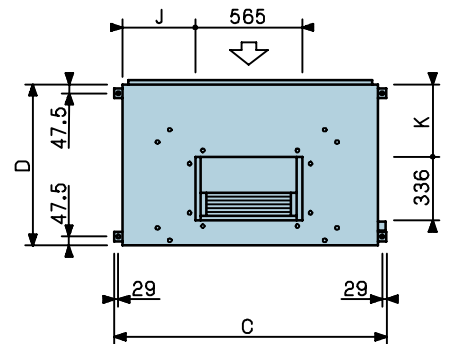
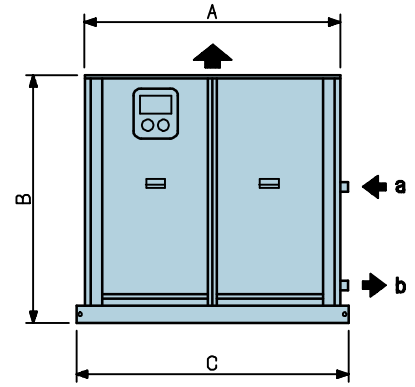
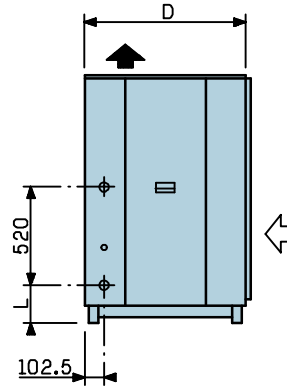
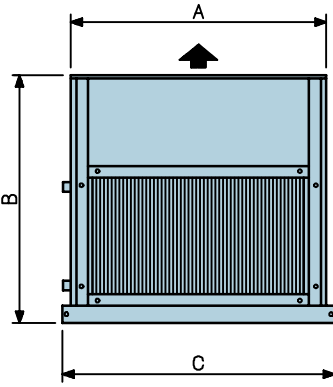

- a : chilled water inlet
- b : chilled water outlet
- Condenser coil intake
- Vertical discharge

OPTIONS

Intake filter box

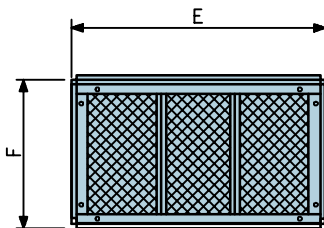

Discharge damper box

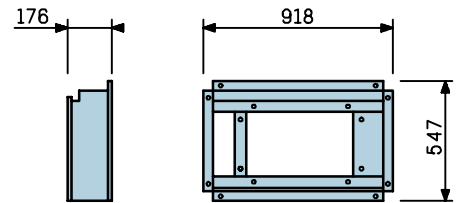

Intake flexible sleeve

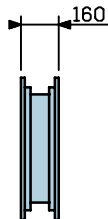
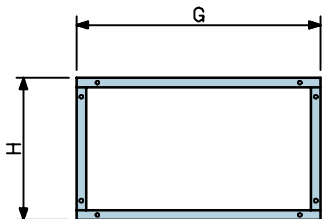

Discharge flexible sleeve

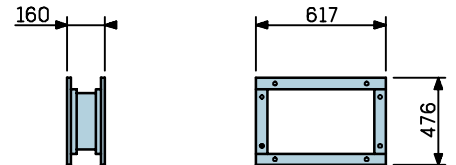

LJ	A	B	C	D	E	F	G	H	J	K	L	Pipes a - b	Mass kg
65	1086	1227	1174	805	952	564	903	528	191	172	244	ø 1" 1/4	245
75													295