



The Oventrop Quality Management System is certified to DIN-EN-ISO 9001

### Application:

Pressure compensation device according to DIN EN 12514-2 for oil pipes according to DIN 4755 in which a thermal conditional volume expansion may occur.

### Description:

Oil expands significantly during warming up. If non-return check valves like foot valves are installed on the tank side, a pressure increase may occur in the suction pipe after the burner is switched off.

This is caused by the warming up of heating oil in the pipework to the ambient temperature and mainly occurs in systems with tanks which are installed at a separate location, e.g. underground tanks or separate heating oil storage rooms.

Even if the tank and the boiler are installed in the same room, this phenomenon may occur due to different temperature layers in the room.

This pressure increase may lead to malfunctions at the quick-acting isolation devices, anti-siphon devices and other components or a breakdown of the boiler.

The pressure stresses the suction pipe and the components installed therein and this may lead to malfunctions.

The pressure compensation device "Olex" absorbs the expanding heating oil by pushing down the spring assisted piston. When the burner starts again, the piston pushes the heating oil back into the suction pipe.

The expansion is displayed by an emerging pin.

### Technical data:

Item no.:	210 70 03
Connection:	both ports female thread $\frac{3}{8}$ " for compression fittings 6, 8, 10 and 12 mm
Fluid:	light heating oil on mineral oil basis, e.g. EL type of heating oil according to DIN 51603-1
Material:	brass
Working pressure:	for use in suction systems, pressure increase up to approx. 2 bar with due consideration of the compensable pipe content
Max. test pressure:	6 bar
Max. compensable pipe content:	730 m <sup>3</sup> with a temperature increase of 40 K (e.g. 0°C to 40°C)

For a pipe according to DIN EN 1057 this corresponds to:

Pipe dimension [mm]: 6 x 1    8 x 1    10 x 1    12 x 1

Max. pipe length [m]: 58    27    15.5    10

The capacity of other components has to be taken into account!

### Installation:

The pressure compensation device "Olex" can be installed in any position using the wall bracket. The space required for the expansion indicator (pin) has to be considered.

The direction of flow is optional.

If an anti-siphon device has been installed, the pressure compensation device should preferably be installed in the direction of flow in front of it.

### Accessories:

#### Compression fittings "Ofix-Oil"

for the connection of copper pipe to the tank side for DN 10 or  $\frac{3}{8}$ ".

Connection set (2-fold)	Item no.
6 mm	212 70 50
8 mm	212 70 51
10 mm	212 70 52
12 mm	212 70 53

#### Brass reinforcing sleeve

for copper pipe with a wall thickness of 1 mm

6 mm	208 39 51
8 mm	208 39 52
10 mm	102 96 51
12 mm	102 96 52

Subject to technical modification without notice.

Product group 9  
ti 145-1/10/MW  
Edition 2009

Printed on paper free from  
chlorine bleaching.

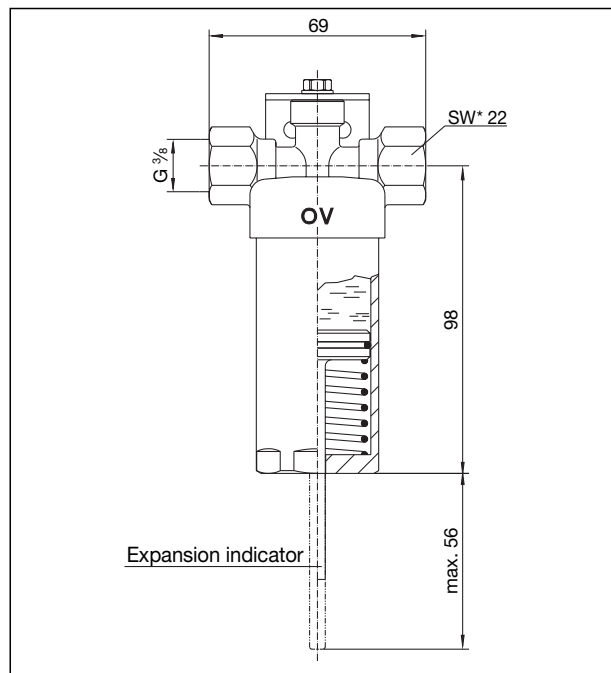
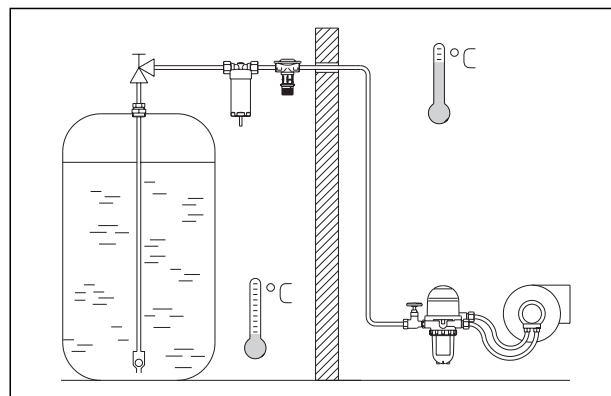

\* SW = spanner size

F. W. OVENTROP GmbH & Co. KG  
Paul-Oventrop-Straße 1  
D-59939 Olsberg, Germany  
Telephone +49(0) 2962 82-0  
Telefax +49(0) 2962 82-450  
E-Mail mail@oventrop.de  
Internet www.oventrop.de

For an overview of our global  
presence visit [www.oventrop.de](http://www.oventrop.de).