



VRT 320

VRT 330





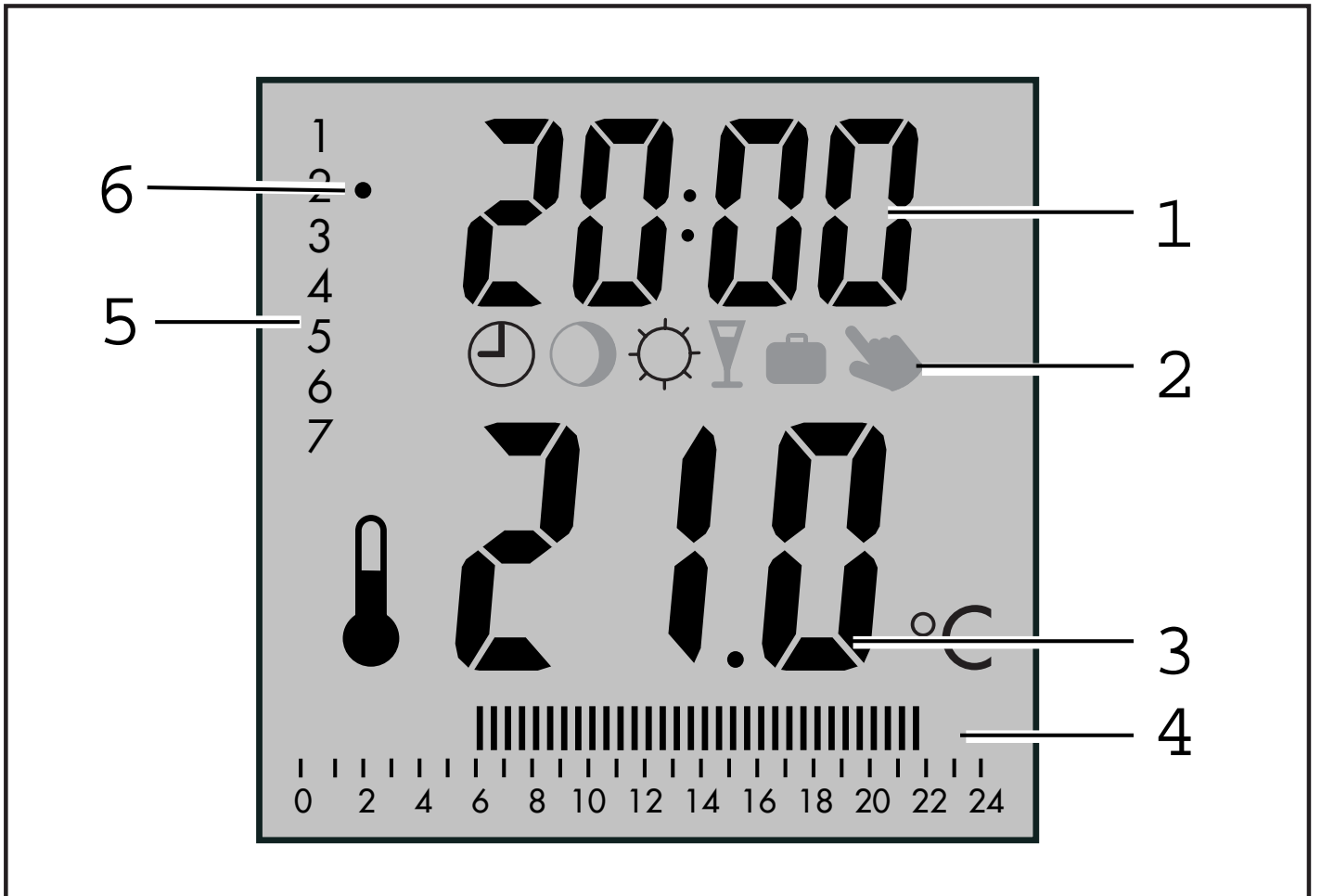
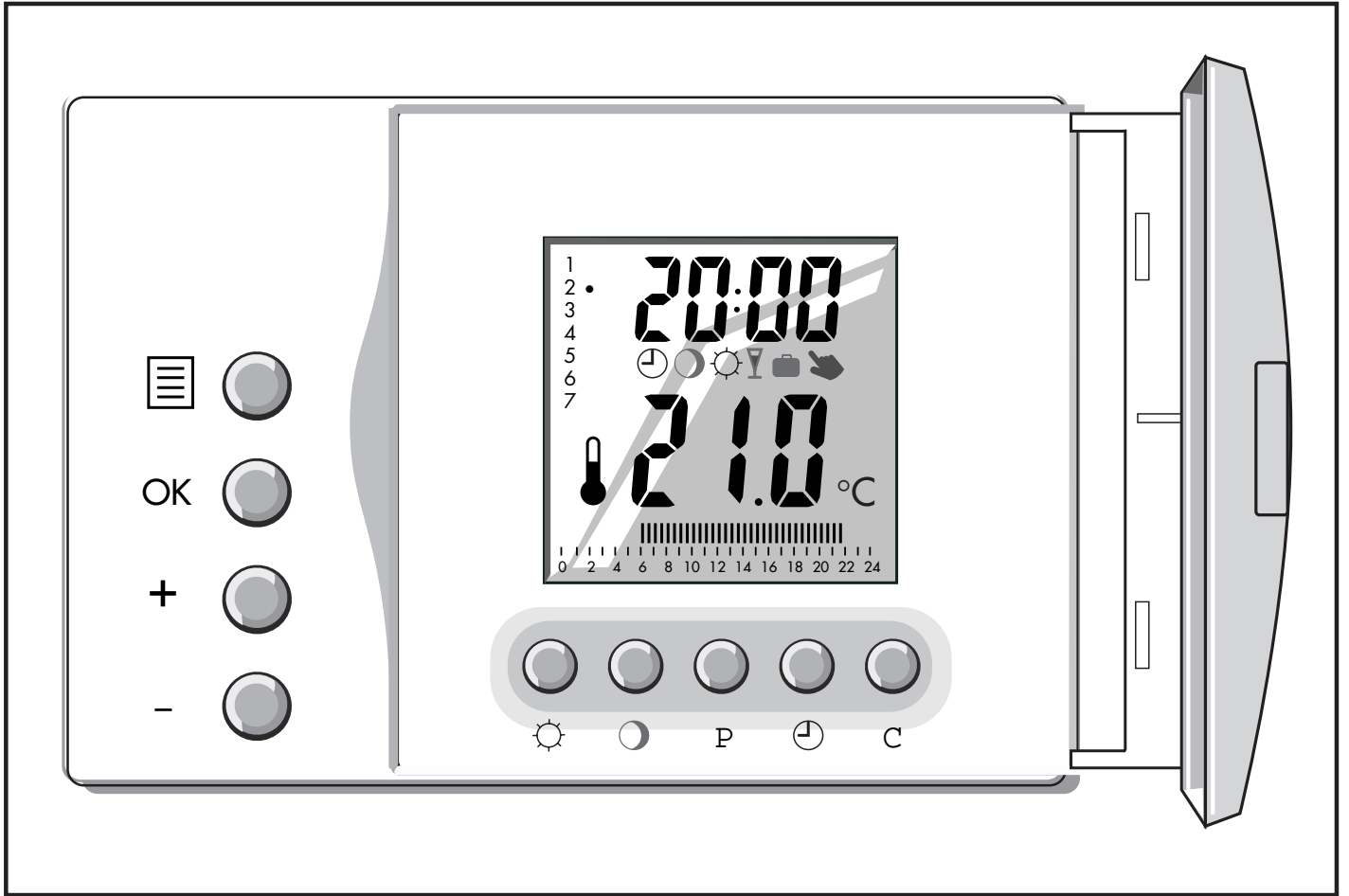

DE	Bedienung4	PL	Obsługa39
	Montage7		Montaż42
GB	Operating9	HU	Kezelés44
	Montage12		Szerelés47
FR	Notice d'utilisation .14	CZ	Návod k obsluze .49
	Notice de montage 17		Návod k montáži .52
ES	Instrucciones	RO	Exploatare54
	de Uso19		Instalare57
	Montaje22	HR	Rukovanje59
	Garantía105		Montaža62
IT	Uso24	SK	Obsluha64
	Installazione27		Montáž67
NL	Bediening29	TR	Kullanım kılavuzu 69
	Montage32		Montaj kılavuzu .72
DK	Betjening34	RUS	Эксплуатация74
	Montage37		Монтаж77
		PT	Operação79
			Montagem82









Bedienung

Lassen Sie in dem Zimmer, indem sich Ihr Raumtemperaturregler befindet, stets alle Heizkörperventile voll geöffnet.

Bedienelemente

-  Betriebsart wählen
- OK Wert bestätigen, weiterblättern
- + Wert erhöhen
- Wert verringern
-  Tagtemperatur einstellen/wählen
-  Absenktemperatur einstellen/wählen
- P Heizzeiten programmieren
-  Uhrzeit und Wochentag einstellen
- C Wert rücksetzen/Zurück springen

Display Übersicht

- 1 Aktuelle Uhrzeit
- 2 Symbole
 -  Die Raumtemperatur wird vom eingegebenen Programm geregelt.
 -   - Absenktzeit
 -   - Heizzeit
 -  Ständige Regelung der Raumtemperatur entsprechend der Absenktemperatur.
 -  Ständige Regelung der Raumtemperatur entsprechend der Tagtemperatur.

▼ Partyfunktion: Bis zum Beginn der nächsten Heizzeit wird die Raumtemperatur entsprechend der Tagtemperatur geregelt.

🗑️ Ferienprogramm: Für die Dauer Ihres Urlaubs wird die Raumtemperatur entsprechend der eingestellten Temperatur geregelt.

👉 Kurzfristige Temperaturveränderung

3 Aktuelle Temperatur

4 Balkenanzeige (I = Heizzeit ein)

5 VRT 330 Wochentage

(1 = Mo, 2 = Di, 3 = Mi, 4 = Do, 5 = Fr, 6 = Sa, 7 = So)

6 VRT 330 Markierung des aktuellen Wochentags

Beschreibung des Gerätes VRT 320

Der VRT 320 ist ein Raumtemperaturregler mit Tages-Heizprogramm. Er verfügt über ein einstellbares Programm. Werkseinstellung:

Heizzeit: 6:00-22:00 Uhr

Beschreibung des Gerätes VRT 330

Der VRT 330 ist ein Raumtemperaturregler mit Wochen-Heizprogramm. Er verfügt über 2 Grundprogramme P1 und P2, ein veränderbares Blockprogramm P3 und ein individuell einstellbares Programm Pi.

VRT 330 Einstellung der Programme		Werksseitig
	Heizzeiten	
P1	6:00-22:00 Uhr	Mo-Fr
P2	7:30-22:30 Uhr	Sa
P3	einstellbar (für mehrere Tage wählbar) 7:30-22:00 Uhr	So
Pi	einstellbar (für jeden Tag individuell)	

Seite

Betriebsart wählen	84
Urlaubsfunktion aktivieren	86
Temperatur kurzfristig verstellen	88
Tagtemperatur einstellen	90
Absenkttemperatur einstellen	90
Uhrzeit und Wochentag einstellen	92
VRT 320 Programm einstellen	94
VRT 330 Grundprogramm auswählen	96
VRT 330 Programm P3 und Pi einstellen	98
Schalten über Telefonfernkontakt	100

Montage

Installation des Reglers

Dieses Gerät darf nur von einem anerkannten Fachmann gemäß den Abbildungen der Seiten 102 bis 104 installiert werden. Dabei sind die bestehenden Sicherheitsvorschriften zu beachten.



Lebensgefahr durch Stromschlag an spannungsführenden Anschlüssen. Vor Arbeiten am Gerät die Stromzufuhr abschalten und vor Wiedereinschalten sichern.

Für Schäden, die durch Nichtbeachtung dieser Anleitung, insbesondere durch Fehlverdrahtung oder mechanische Beschädigung entstehen, übernehmen wir keine Haftung.

Zweipunkt- oder Stetig-Regelung (Seite 103)

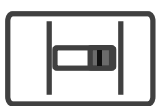

A Z

Zweipunkt-Regelung (Werkseinstellung) ist erforderlich, wenn die Leistung des Heizgerätes deutlich über dem errechneten Wärmebedarf liegt (z. B. um eine größere Warmwasserleistung zu erzielen).



A Z

Stetig-Regelung empfiehlt sich, wenn die Heizleistung dem errechneten Wärmebedarf entspricht.

Telefonfernschalter (TEL) anschließen

Der Schaltausgang des Telefonfernschalters wird an der Klemme TEL des Reglers angeschlossen (siehe Abbildung Seite 104).

Bitte beachten Sie die Installationsanleitung des Telefonfernschalters.





Technische Daten

Gerätebezeichnung	VRT 320/VRT 330
Betriebsspannung	max. 30 V
Stromaufnahme	< 10 mA
Gangreserve Uhr	0,5 h
Tagtemperaturbereich	5 ... 30°C
Absenkttemperaturbereich	5 ... 20°C
Schaltdifferenz (Z)	1 K
Proportionalbereich (A)	2 K
Anschlussleitungen	3x0,75 mm ²
Schutzart	IP 30
Schutzklasse	III
Betriebstemperatur	+ 5 ... + 50 °C
Zul. Lagertemperatur	- 20 ... + 65 °C
Abmessungen	111 x 81 x 33 mm
Schaltstrom Klemmen TEL	1 ... 3 mA







1 Operating

Ensure that all the regulating valves are fully opened on the radiators located in the same room as the room-temperature control device.

Operating elements

-  Choose operating mode
- OK Confirm value, continue
- + Raise value
- Reduce value
-  Adjust/Choose day temperature
-  Adjust/Choose night temperature
- P Set heating periods
-  Set date and time
- C Undo, return

Display, Overview

- 1 Actual time
- 2 Symbols
 -  The room temperature is controlled by the pre-set program.
 -   - "Reduce" setting
 -   - Heating setting
 -  The room temperature is permanently controlled according to the reduced (night) temperature.
 -  The room temperature is permanently controlled according to the day temperature.

- ▽ Override mode: The room temperature is controlled according to the day temperature until the next reduce setting.
- 🗑️ Holiday program: during the holidays the room temperature is controlled according to reduced the adjusted temperature.
- 👉 Temporarily change of the temperature

- 3 Actual temperature
- 4 Heating indicator (I = Heating period on)
- 5 VRT 330 Weekdays (1 = mon., 2 = tue., 3 = wed., 4 = thur., 5 = fri., 6 = sat., 7 = sun.)
- 6 VRT 330 Marking of the actual weekday

Device description

VRT 320 is a programmable roomthermostat.

The thermostat already carries out a sensible heating programme: Pre-set values

Heating period: 6:00-22:00

VRT 330 is a 7 day programmable roomthermostat.

The thermostat has 2 basic programs P1 and P2, an adjustable Programm P3 and an individual programm Pi.

VRT 330 Setting of the programs		Pre-set values
	Heating periods	
P1	6:00-22:00	Mo-Fr
P2	7:30-22:30	Sa
P3	adjustable (for several days) 7:00-22:00	Su
Pi	adjustable (separate for each day)	

page

Choose the operating mode84
Activate the holiday program86
Change the temperatur temporarily88
Adjust the day temperature90
Adjust the night temperature90
Set the date and time92
VRT 320 Set program94
VRT 330 Choose a program96
VRT 330 Set program P3 or Pi98
Connect with remote-control switch100

2 Installation

This system **MUST** be fitted by a qualified and approved installation engineer, proceeding as shown in the illustrations on pages 102 to 104. The relevant safety guidelines should be followed at all times.



There is a danger of fatal injury from touching live components. Always shut off the power supply to the system (and ensure it cannot be reconnected) BEFORE carrying out installation or maintenance work.

Note that we will accept no liability whatsoever for injury or damage resulting from failure to observe these instructions. This condition applies especially to incorrect wiring and/or defective mechanical installation.

Two-point or constant regulation (page 103)

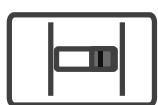

A Z

Two-point regulation (factory-adjustment) is required if the power rating of the heating system is considerably more than the calculated heat requirement (e.g. in order to achieve a greater hotwater capacity).



A Z

Constant regulation is recommended if the heat rating corresponds to the calculated heating requirement.

Connect a remote-control switch (TEL) (not currently available in the UK)

The remote-control switch is connected on terminal TEL (see page 104).

Please note the installations instructions of the remote-control switch.





Technical specification

Device type	VRT 320/VRT 330
Operating voltage	max. 30 V
Power consumption	10 mA
Power reserve	0,5 h
Day temperature range	5 ... 30°C
Night temperature range	5 ... 20°C
Switching difference (Z)	1 K
Proportional range (A)	2 K
Connection leads	3x0,75 mm ²
Protection rating	IP 30
Protection classification	III
Operating temperature	+ 5 ... + 50 °C
Permitted storage temp.	- 20 ... + 65 °C
Dimensions	111 x 81 x 33 mm
Power terminal TEL	1...3 mA







Utilisation

Laissez toujours tous les robinets des radiateurs complètement ouverts dans la pièce où se trouve votre thermostat d'ambiance.

Organes de commande

-  Sélectionner le mode de fonctionnement
- OK Confirmer la valeur, avancer dans le programme
- + Augmenter la valeur
- Réduire la valeur
-  Régler/Choisir la température jour
-  Régler/Choisir la température nocturne
- P Programmer les heures de chauffage
-  Régler les heures et jours de semaine
- C Revenir en arrière/Restituer la valeur

Vue d'ensemble de l'écran

- 1 Heure actuelle
- 2 Symboles
 -  La température ambiante est régulée par le programme sélectionné.
 -   - Période d'abaissement
 -   - Période de chauffe
 -  Régulation permanente de la température ambiante en fonction de la température d'abaissement.
 -  Régulation permanente de la température ambiante en fonction de la température jour

▼ Fonction party : la température ambiante est réglée en fonction de la température jour jusqu'à la prochaine période d'abaissement.

🧳 Programme congés : la température ambiante est réglée en fonction de la température demandée pour la durée de vos vacances.

👉 Brève modification de température

3 Temperature actuelle

4 Affichage barres (I = Période de chauffe)e)

5 VRT 330 Jour de la semaine

(1 = lu, 2 = ma, 3 = me, 4 = je, 5 = ve, 6 = sa, 7 = di)

6 VRT 330 Marquage du jour en cours de la semaine

Description de l'appareil

Le VRT 320 est un thermostat d'ambiance avec programmation journalière du chauffage.

Le thermostat dispose d'un programme modifiable

Réglés d'usine:

période de chauffe: 6:00-22:00 heures.

Le VRT 330 est un thermostat d'ambiance avec programmation hebdomadaire du chauffage.

Le thermostat dispose de 2 programmes de base P1 et P2, d'un programme bloc modifiable P3 et d'un programme individuel réglable Pi.

VRT 330 Réglage des programmes périodes de chauffe		Réglés d'usine
P1	6:00-22:00 heures	du lu au ve
P2	7:30-22:30 heures	sa
P3	réglable (pour plusieurs jours au choix) 7:00-22:00	di
Pi	réglable (pour chaque jour individuellement)	

page

Choix du mode de fonctionnement	.84
Activer la fonction congés	.86
Brève modification de la température	.88
Réglage de la température jour	.90
Réglage de la température d'abaissement	.90
Réglage jour et heure	.92
VRT 320 Réglage programme	.94
VRT 330 Choix du programme de base	.96
VRT 330 Réglage des programmes P3 et Pi	.98
Enclenchement par téléphone	.100

Montage

Installation du thermostat d'ambiance

Cet appareil ne peut être ouvert et installé que par un professionnel qualifié conformément aux schémas des pages 102 à 104 . Il convient, à cet effet de respecter les consignes de sécurité existantes.



Danger d'électrocution sur les raccordements conducteurs de courant. Avant les travaux sur l'appareil, couper l'alimentation secteur et mettre des coupe-circuits avant la remise en marche.

Nous ne sommes pas responsables des dommages pouvant découler du non-respect de ce mode d'emploi, des câblages défectueux ou détériorations mécaniques.

Régulation à deux positions (par plus ou moins) ou réglage progressif (page 103)

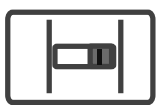

A Z

La régulation à deux positions (réglage usine) est nécessaire quand la puissance de l'appareil de chauffage est nettement au-dessus de la consommation de chaleur calculée (pour obtenir par exemple une puissance d'eau chaude plus importante).



A Z

La régulation progressive est recommandée si la puissance de chauffage correspond à la consommation de chaleur calculée.

Raccordement du commutateur téléphonique à distance (TEL)

Le commutateur est raccordé sur les bornes TEL de la régulation (voir schéma page 104) Merci de suivre la notice d'installation du commutateur téléphonique.





Données techniques

Type d'appareil	VRT 320/VRT 330
Tension de fonctionnement	max. 30 V
Puissance absorbée	< 10 mA
Réserve de marche	0,5 h
Plage de température jour	5 ... 30°C
Plage de temp. d'abaissement	5 ... 20°C
Différence de commutation(Z)	1 K
Plage proportionnelle (A)	2 K
Câbles de raccordement	3x0,75 mm ²
Type de protection	IP 30
Classe de protection	III
Temp. de fonctionnement	+ 5 ... + 50 °C
Temp. stockage admise	- 20 ... + 65 °C
Dimensions	111 x 81 x 33 mm
Puissance de rupture	1...3 mA







Instrucciones de Uso

En la habitación en la que se encuentre su termostato, hay que dejar siempre completamente abiertas todas las válvulas del radiador

Elementos de mando

-  Seleccionar modo de funcionamiento
- OK Confirmar valor, pasar página
- + Aumentar valor
- Disminuir valor
-  Ajustar/seleccionar temperatura diurna
-  Ajustar/seleccionar descenso temperatura
- P Programar períodos calentamiento
-  Ajustar hora + día semana
- C Retroceder/ restaurar valor

Vista general del Display

- 1 Hora actual
- 2 Símbolos
 -  La temperatura ambiente es regulada por el programa vigente
 -   - período de descenso / nocturna
 -   - período de calefacción
 -  Regulación constante de la temperatura ambiente, de acuerdo con el descenso de temperatura.
 -  Regulación constante de la temperatura ambiente, según la temperatura diurna.

- ▽ Función para guateque: hasta el próximo período de descenso, la temperatura es regulada de acuerdo con la temp. diurna.
- 🗑 Programa para vacaciones: Mientras duren sus vacaciones, la temp. ambiental será regulada según la temp. prefijada de antemano.
- 👉 Variación de la temperatura a corto plazo

- 3 Temperatura actual
- 4 Indicación de barra (I = tiempo de calentamiento, conectado)
- 5 VRT 330 Día de la semana:
(1= lunes, 2= martes, 3= miércoles, 4 = jueves, 5 = viernes, 6 = sábado, 7 = domingo)
- 6 VRT 330 Señalización del día de la semana actual

Descripción del aparato

El VRT 320 es un termostato de ambiente, con programación diaria de calefacción. De fábrica:

Períodos de calefacción De 6:00-22:00 horas

El VRT 330 es un cronotermostato de ambiente, con programación semanal digital de calefacción. El regulador dispone de 2 programas básicos, el P1 y el P2, de un programa de bloque susceptible de ser variado P3 y de un programa Pi ajustable individualmente.

VRT 330 Ajuste de los programas		De
	Períodos de calefacción	fábrica
P1	De 6:00-22:00 horas	Lun-Vie
P2	De 7:30-22:30 horas	Sábado
P3	Ajustable (seleccionable para varios días) 7:00-22:00	Domingo
Pi	Ajustable (para cada día en particular)	

Página

Seleccionar modo de funcionamiento	84
Activar funcionamiento en vacaciones	86
Variar temperatura a corto plazo	88
Ajustar la temperatura diurna	90
Ajustar el descenso de temperatura	90
Ajustar la hora y el día de la semana	92
VRT 320 Ajustar programa	94
VRT 330 Seleccionar el programa básico	96
VRT 330 Ajustar programa P3 y Pi	98
Conmutación mediante conexión telefónica . . .	100

Instalación del regulador

Este aparato sólo puede ser abierto e instalado según las figuras de la Página 102 a la Página 104 por un especialista cualificado. Para ello, habrán de tenerse en cuenta las normas de seguridad vigentes.



Peligro de daños físicos por contacto eléctrico en las conexiones sometidas a tensión. Antes de manipular el aparato, desconectar la alimentación eléctrica y, antes de reconectar la corriente.

No asumimos responsabilidad civil alguna por daños que puedan surgir por la inobservancia de las presentes instrucciones, en especial, por el cableado defectuoso, ni por desperfectos mecánicos que puedan surgir.

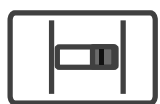
Regulación de dos puntos o continua (pág 103)

A Z

La regulación de dos puntos (ajuste del fabricante) es necesaria cuando la potencia del calentador se sitúa claramente por encima de la necesidad de calor calculada (p. ij. para lograr una mayor producción de agua caliente).



A Z

La regulación continua se recomienda para cuando la potencia de calefacción corresponde a las necesidades de calor calculadas.

Conectar teleinterruptor telefónico (TEL)

El teleinterruptor telefónico se conecta a los bornes TEL del regulador (ver Figura, Página 104). Observe por favor, las instrucciones para la instalación del teleinterruptor telefónico.





Características técnicas

Denominación del aparato	VRT 320/VRT 330
Tensión de servicio	max. 30 V
Alimentación	< 10 mA
Reserva de marcha	0,5 h
Gama de temperaturas diurnas	5 ... 30°C
Gama de descensos de temp.	5 ... 20°C
Diferencia de conmutación (Z)	1 K
Rango proporcional (A)	2 K
Cables de conexión	3x0,75 mm ²
Tipo de protección	IP 30
Clase de protección	III
Temperatura de servicio	+ 5 ... + 50 °C
Temp. de almacenaje admisible	- 20 ... + 65 °C
Dimensiones	111 x 81 x 33 mm
Entrada TEL act.:	1...3 mA







Uso

Lasciate completamente aperte tutte le valvole dei caloriferi nella stanza in cui si trova il termostato.

Elementi d'uso

-  impostazione del modo operativo
- OK conferm del valore, continuare a sfogliare
- + aumentare il valore
- diminuire il valore
-  impostazione della temperatura ambiente diurna
-  impostazione della temperatura di abbassamento
- P impostazione dei periodi di riscaldamento
-  impostazione ora e giorno della settimana
- C cancella indietro/ristabilire valori

Visualizzazione sul display

- 1 ora attuale
- 2 simboli
 -  la temperatura ambiente viene regolata da un programma orario prestabilito
 -   - periodo di attenuazione
 -   - periodo di riscaldamento
 -  regolazione continua della temperatura ambiente attenuata
 -  regolazione continua della temperatura ambiente diurna

- ▼ funzione party: fino al successivo periodo di attenuazione, la temperatura ambiente viene regolata secondo l'impostazione diurna
 - 🗑️ programma ferie: per la durata della vostra assenza, la temperatura ambiente viene regolata secondo l'impostazione preferita
 - 👉 modifica immediata temperatura
- 3 temperatura attuale
 - 4 barra di segnalazione (I: periodo riscaldamento attivato)
 - 5 VRT 330 giorni della settimana
 - 6 VRT 330 indicazione dell'attuale giorno della settimana

Descrizione del prodotto

Il VRT 320 è un termostato ambiente con programma giornaliero di riscaldamento. Il termostato È disponibile con un programma

Periodi di riscaldamento: 6:00-22:00

Il VRT 330 è un termostato ambiente con programma settimanale di riscaldamento.

Il termostato è disponibile con due programmi base P1 e P2, un programma modificabile a blocchi P3 ed un programma individuale regolabile Pi.

VRT 330 Impostazione dei programmi		Giorni attivati
	Periodi di riscaldamento	
P1	6:00-22:00	lun-ven
P2	7:30-22:30	sab
P3	Regolabile (ripetibile per più giorni) 7:00-22:00	dom
Pi	Regolabile (per ogni singolo giorno)	

Pagina

Impostazione del modo operativo	84
Impostazione programma vacanze	86
Modifica temporanea temp. ambiente	88
Impostazione della temperatura diurna	90
Impostazione della temperatura attenuata ..	90
Impostazione ora e giorno della settimana ..	92
VRT 320 impostazione del programma	94
VRT 330 scelta del programma di base	96
VRT 330 impostazione dei programmi P3 e Pi	98
Inserire il comando telefonico a distanza ...	100

Installazione

Installazione del termostato

Questi apparecchi devono essere aperti ed installati da un tecnico qualificato, secondo le figure da pag. 102 a pag. 104. Osservare le seguenti prescrizioni di sicurezza.



Pericolo di folgorazioni a causa di tensione presente nei cavi elettrici.

Prima di operare sull'apparecchio togliere la tensione ed assicurarsi che alla fine dei lavori venga riattivata.

Non rispondiamo dei danni causati dalla non osservanza di queste istruzioni.

Impostazione su due punti oppure continua (p. 103)



A Z

La regolazione su due punti (impostazione a stabilimento di produzione) è necessario allorquando le prestazioni richieste all'apparecchio sono nettamente superiori al calcolato fabbisogni termico (ad es. per ottenere un maggiori prestazioni nell'erogazione di acqua calda).



A Z

Una regolazione contratto è consigliabile quando le prestazioni dell'apparecchio devono corrispondere al calcolato fabbisogni termico.

Collegare il comando telefonico a distanza

Il comando telefonico a distanza viene collegato ai morsetti TEL del termostato (vedi fig. pag. 104).

Per l'installazione e l'uso del comando telefonico a distanza, osservare le istruzioni ad esso allegate.





Dati Tecnici

Parametri	VRT 220/VRT 330
Tensione di funzionamento	max. 30 V
Corrente di inserimento	< 10 mA
Reserva di carica	0,5 h
Campo temperatura diurna	5 ... 30°C
Campo temperatura attenuata	5 ... 20°C
Differenza d'inserimento (Z)	1 K
Ambito proporzionale (A)	2 K
Cavi di collegamento	3x0,75 mm ²
Grado di protezione	IP 30
Classe di protezione	III
Temperatura di funzionamento	+ 5 ... + 50 °C
Temp. di stoccaggio ammessa	- 20 ... + 65 °C
Dimensioni	111 x 81 x 33 mm
Ingresso TEL	1...3 mA







Bediening

Zorg er voor dat in de ruimte waar de klokthermostaat is gemonteerd altijd de radiatorcranken volledig zijn geopend.

Bedieningselementen

-  Bedrijfsfunctie kiezen
- OK Waarde bevestigen, doorbladeren
- + Waarde verhogen
- Waarde verlagen
-  Dagtemperatuur instellen/kiezen
-  Verlagingsperiode instellen/kiezen
- P Verwarmingsperioden programmeren
-  Tijd en dag instellen
- C Terugstappen/waarde corrigeren

Displayoverzicht

- 1 Actuele tijd
- 2 Symbolen
 -  Automatisch volgens geprogrammeerde perioden
 -   - Verlagingsperiode
 -   - Verwarmingsperiode
 -  Constante regeling volgens de ingestelde verlagingsperiode.
 -  Constante regeling volgens de ingestelde dagtemperatuur.

▼ Partyfunctie: tot de eerstvolgende verla-
gingsperiode wordt de temperatuur volgens
de ingestelde dagtemperatuur geregeld.

🗑️ Vakantieprogramma: gedurende uw vakan-
tie wordt de kamertemperatuur volgens de
ingestelde temperatuur geregeld.

👉 Kortstondige temperatuurwijziging

- 3 Actuele kamertemperatuur
- 4 Balkenaanwijzing (I = verwarming aan)
- 5 VRT 330 Dag van de week (1 = ma, 2 = di,
3 = wo, 4 = do, 5 = vr, 6 = za, 7 = zo)
- 6 VRT 330 Markering van de actuele dag van de
week

Productomschrijving

De VRT 320 is een aan/uit regelaar met een per dag programmeerbare schakelklok voor de besturing van een CV-toestel. De regelaar beschikt over een aan te passen programma. Fabrieksinstelling

verwarmingsperioden: 6:00-22:00 uur

De VRT 330 is een aan/uit of modulerende regelaar met een zeven dagen programmeerbare schakelklok voor de besturing van een CV-toestel.

De regelaar beschikt over twee vast ingestelde basisprogramma's P1 en P2, een aan te passen blokprogramma P3 en een individueel instelbaar programma Pi.

VRT 330 Geprogrammeerde verwarmingsperioden		Dagen van de week
P1	6:00-22:00 uur	Ma - Vrij
P2	7:30-22:30	Za
P3	Instelbaar (voor meerdere dagen toepasbaar) 7:00-22:00 uur	Zo
Pi	Instelbaar (voor elke dag individueel)	

Bediening

Pagina

Bedrijfsfunctie kiezen	84
Vakantieprogramma activeren	86
Kamertemperatuur kortstondig wijzigen	88
Dagtemperatuur instellen	90
Verlagingstemperatuur instellen	90
Tijd en dag van de week instellen	92
VRT 320 Programma instellen	94
VRT 330 Basisprogramma's kiezen	96
VRT 330 Programma's P3 en Pi instellen	98
Inschakelen op afstand via de telefoon	100

Montage van de regelaar en de ontvanger

Dit product mag alleen door een deskundige installateur worden geopend en volgens de afbeeldingen van pagina 102 tot 104 worden gemonteerd.

Hiervoor moeten de bestaande veiligheidsvoorschriften in acht worden genomen.



Levensgevaar door elektrocutie van onder spanning staande delen. Bij werkzaamheden aan het toestel altijd de stroomtoevoer afsluiten en beveiligen tegen ongeoorloofd/per ongeluk weer inschakelen.

Voor schade die voortvloeit uit het niet opvolgen van de aanwijzingen uit deze handleiding en in het bijzonder schade ontstaan door het fout aansluiten van de bedrading of mechanische beschadiging zijn wij niet aansprakelijk.

Aan/uit- of continueregeling (pagina 103)

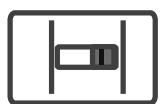

A Z

Tweestandenregeling (**Z**) (fabrieksinstelling) is vereist als de capaciteit van het verwarmingsapparaat duidelijk boven de berekende warmtebehoefte ligt (b.v. om een grotere warmwatercapaciteit te bereiken).



A Z

Continueregeling (**A**) valt aan te bevelen als de verwarmingscapaciteit overeenkomt met de berekende warmtebehoefte.

Telefoonafstandsbediening aansluiten (n.v.t. in NL)

De telefoon afstandbediening wordt aangesloten aan de klemmen TEL van de regelaar (zie afbeelding pagina 104). Volg de aanwijzingen op uit de installatiehandleiding van de telefoonafstandsbediening.

Technische gegevens





Productbenaming	VRT 320/VRT 330
Bedrijfsspanning regelaar	max. 30 V
Opgenomen vermogen	< 10 mA
Gangreserve	0,5 h
Dagtemperatuur	5 ... 30°C
Verlagingstemperatuur	5 ... 20°C
Schakelverschil (Z)	1 K
Proportioneel bereik (A)	2 K
Doorsnede van de aansluitleidingen	3x0,75 mm ²
Beschermingssoort	IP 30
Beschermingsklasse	III
Bedrijfstemperatuur	+ 5 ... + 50 °C
Max. toelaatbare opslagtemperatuur	- 20 ... + 65 °C
Afmetingen (lxbxd)	111 x 81 x 33 mm
Ingang TEL	1...3 mA









Betjening

Alle radiatortermostater i rummet, hvor rumtermostaten befinder sig, skal være helt åbne hele tiden.

Betjeningslementer

-  Valg af driftsart
- OK Acceptér værdi, bladre videre
- + Forhøje værdi
- Reducere værdi
-  Indstilling/valg af dagtemperatur
-  Indstilling/valg af nattemperatur
- P Programmering af opvarmningsperioder
-  Indstilling af klokkeslæt/ugedag
- C Skridt tilbage/annullér værdi

Display oversigt

- 1 Aktuelt klokkeslæt
- 2 Symboler
 -  Rumtemperaturen styres af et program.
 -   - Nattemperatur/natsænkning.
 -   - Dagtemperatur.
 -  Rumtemperaturen styres af den indstillede nattemperatur.
 -  Rumtemperaturen styres af den indstillede dagtemperatur.

▼ Party-funktion: Indtil næste sænkingsperiode (nattemperatur) styres rumtemperaturen efter dagtemperatur

👛 Ferie-program: Rumtemperaturen styres af den indstillede temperatur i ferie-perioden

👉 Midlertidig ændring af temperatur

3 Aktuel dagtemperatur

4 Bjælkevisning (I = varmeperiode til)

5 VRT 330 Ugedage

(1 = ma, 2 = ti, 3 = ons, 4 = to, 5 = fre, 6 = lø, 7 = sø)

6 VRT 330 Markering af aktuel ugedag

Beskrivelse af rumtermostaten

VRT 320 rumtermostat med dagprogram har et regulerbart program Pi.

Fabriksindstilling:

Varmeperioder: 6:00-22:00

VRT 330 rumtermostat med ugeprogram har to grundprogrammer P1 og P2, et regulerbart blokprogram P3 og et individuelt regulerbart program Pi.

VRT 330 Indstilling af programmerne		Fabriksindstilling
	Varmeperioder	
P1	6:00-22:00	Ma-fr
P2	7:30-22:30	Lø
P3	Regulerbar (kan vælges for flere dage) 7:00-22:00	Sø
Pi	Regulerbar (individuet for hver dag)	

Side

Valg af driftsart	84
Aktivering af feriedrift	86
Midlertidig ændring af temperatur	88
Indstilling af dagtemperatur	90
Indstilling af nattemperatur	90
Indstilling af klokkeslæt og ugedag	92
VRT 320 Indstilling af program	94
VRT 330 Valg af program	96
VRT 330 Indstilling af program P3 og Pi	98
Styring via telefon	100

Montage

Installation af rumtermostaten, funkmodtageren

Nærværende rumtermostat må kun åbnes af en autoriseret installatør, som installerer den i henhold til skitserne på side 102 til 104. Herved skal de gældende sikkerhedsregler overholdes.



Livsfare på grund af elektriske stød på spændingsførende tilslutninger. Før der udføres arbejde på anlægget, skal strømmen slås fra og sikres mod genindkobling.

Vaillant påtager sig ikke ansvaret for skader, der opstår ved at nærværende vejledning ikke følges; dette gælder især forkert el-installation eller beskadigelse af mekanikken.

Toppunkts- eller kontinuerlig-regulering (side 103)



A Z

Toppunkts-regulering (fabriksindstilling) er nødvendig, hvis kedlens ydelse tydeligt ligger over det beregnede varmebehov (f.eks. for at opnå en større varmtvandsydelse).



A Z

Kontinuerlig-regulering kan anbefales, hvis varmeydelsen svarer til det beregnede varmebehov.

Tilslutning af telefonstyring (TEL)

Telefonstyringen tilsluttes på klemmerne TEL på styringen (se fig. på side 104). Installationen foretages som beskrevet i den tilhørende vejledning.





Tekniske data

Apparattype	VRT 320/VRT 330
Driftsspænding	maks. 30 V
Strømforbrug	< 10 mA
Gangreserve	0,5 h
Dagtemperatur-område	5 ... 30°C
Nattemperatur-område	5 ... 20°C
Kontaktdifference (Z)	1 K
Proportionalområde (A)	2 K
Tilslutningsledninger	3x0,75 mm ²
Beskyttelsesgrad	IP 30
Beskyttelsesklasse	III
Driftstemperatur	+ 5 ... + 50 °C
Tilladt opbevaringstemp.	- 20 ... + 65 °C
Mål	111 x 81 x 33 mm
Indgang TEL	1...3 mA







Obsługa

W pokoju, w którym znajduje się regulator temperatury, wszystkie zawory termostaticzne na grzejnikach powinny być całkowicie otwarte.

Elementy obsługi

-  Wybór rodzaju pracy
- OK Zatwierdzenie wartości, przejście dalej
- + Podwyższenie wartości
- Obniżenie wartości
-  Nastawienie / wybór temperatury dziennej
-  Nastawienie / wybór temperatury obniżonej
- P Programowanie okresów grzewczych
-  Nastawienie czasu zegara i dnia tygodnia
- C Krok do tyłu / powrót do poprzedniej wartości

Wskaźniki na wyświetlaczu

- 1 Aktualny czas zegara
- 2 Symbole:
 -  Temperatura pomieszczenia regulowana jest przez ustawiony program
 -   - Temp. pomieszczenia obniżona
 -   - Temp. pomieszczenia dzienna
 -  Obniżona temperatura pomieszczenia na stałe
 -  Dzienna temperatura pomieszczenia na stałe

- ▼ Funkcja "Party": podwyższenie temperatury pomieszczenia najbliższego okresu temperatury obniżonej
 - 👛 Program wakacyjny: W okresie urlopu temperatura pomieszczenia będzie regulowana odpowiednio do zadanej wartości
 - 👉 Krótkotrwała zmiana temperatury
- 3 Aktualna temperatura pomieszczenia
 - 4 Wskaźnik kreskowy (I = przedział grzania)
 - 5 VRT 330 Dni tygodnia
(1=poniedziałek, 2=wtorek, 3=środa, 4=czwartek, 5=piątek, 6=sobota, 7=niedziela)
 - 6 VRT 330 Wskazanie aktualnego dnia tygodnia

Opis regulatora

VRT 320 jest pokojowym regulatorem temperatury z dobowym programem ogrzewania.

Regulator posiada jeden ustawialny program dla centralnego ogrzewania.

Okresy: Czas grzania 6:00-22:00

VRT 330 jest regulatorem temperatury pomieszczenia z programem tygodniowym.

Regulator posiada dwa podstawowe, stałe programy P1 i P2, program ustawialny, blokowy P3 i program ustawialny na każdy dzień tygodnia Pi.

VRT 330 Programy		Okresy
	Czas grzania	
P1	6:00-22:00	Po-Pt
P2	7:30-22:30	So
P3	ustawialny (dla kilku dni) 7:00-22:00	Ni
Pi	ustawialny (indywidualnie dla każdego dnia)	

Seite

Wybór trybu pracy	84
Aktywacja funkcji urlopowej	86
Krótkotrwałe przestawienie temperatury	88
Ustawienie temperatury dziennej	90
Ustawienie temperatury obniżonej	90
Ustawienie godziny i dnia tygodnia	92
VRT 320 Ustawienie programu	94
VRT 330 Wybór programu podstawowego ...	96
VRT 330 Ustawienie programów P3 i Pi	98
Przełączenie przez telefon	100

Montaż regulatora

Regulator może być otwierany i instalowany (zgodnie z rysunkami na stronach 102 do 104), tylko przez firmowego lub autoryzowanego serwisanta firmy Vaillant. Należy przestrzegać zasady bezpieczeństwa.



Niebezpieczeństwo dla życia przez porażenie prądem. Przed przystąpieniem do pracy odłączyć prąd elektryczny od urządzenia i zabezpieczyć przed przypadkowym włączeniem.

Za szkody powstałe w wyniku nie przestrzegania zasad podanych w niniejszej instrukcji, złych połączeń elektrycznych lub mechanicznych uszkodzeń, firma Vaillant nie ponosi odpowiedzialności.

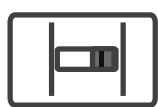
Regulacja dwupunktowa, czy regulacja ciągła (strona 103)**A Z**

Regulacja dwupunktowa (nastawa fabryczna) jest potrzebna, gdy moc kotła grzejnego jest znacznie większa od wyliczonego zapotrzebowania ciepła (np. aby otrzymać zwiększone podawanie ciepłej wody).

**A Z**

Stosowanie regulacji ciągłej jest zalecane wtedy, gdy moc grzejna odpowiada obliczonemu zapotrzebowaniu ciepła.

Podłączenie zdalnego przełącznika telefonicznego (TEL).

Zdalny przełącznik telefoniczny jest podłączony do zacisku TEL regulatora (patrz rysunek na stronie 104). Należy przestrzegać zasady podane w instrukcji instalacyjnej zdalnego przełącznika telefonicznego.





Techniczne dane

	VRT 320/VRT 330
Napięcie zasilania	Maks 30V
Pobór prądu	< 10 mA
Rezerwa zasilania	0,5 h
Zakres temperatury dziennej	5 ... 30°C
Zakres temperatury obniżonej	5 ... 20°C
Histereza (Z)	1 K
Zakres proporcjonalności (A)	2 K
Połączenie elektryczne	3x0,75 mm ²
Stopień ochrony	IP 30
Klasa ochrony	III
Temperatura pracy	+ 5 ... + 50 °C
Zakres temp. przechowywania	- 20 ... + 65 °C
Wymiary	111 x 81 x 33 mm
Podłączenie tel.	1...3 mA







Kezelés

Abban a helyiségben, ahol a szobahőmérséklet-szabályozó található, mindig tartsa nyitva az összes fűtőtest szelepét.

Kezelőelemek

-  Üzemmódkapcsoló
- OK Érték elfogadása, továbblapozás
- + Érték növelése
- Érték csökkentése
-  Nappali hőmérséklet beállítása/választása
-  Csökkentett hőmérséklet beállítása/választása
- P Fűtésidők programozása
-  Pontos idő és hét napjának beállítása
- C Visszalépés / érték törlése

Kijelző

- 1 Aktuális időpont
- 2 Szimbólumok
 -  A szobahőmérsékletet a megadott program szabályozza.
 -   - Csökkentett hőmérséklet ideje
 -   - Fűtés ideje
 -  Szobahőmérséklet folyamatos szabályozása a csökkentett hőmérsékletnek megfelelően
 -  Szobahőmérséklet folyamatos szabályozása a nappali hőmérsékletnek megfelelően

▼ Party-funkció: a következő csökkentési időig a szobahőmérsékletet a rendszer a nappali hőmérsékletnek megfelelően szabályozza

👛 Szabadság-program: szabadsága idején a rendszer a szobahőmérsékletet a beállított hőmérsékletnek megfelelően szabályozza

➡ Rövid idejű hőmérsékletváltozás

3 Aktuális hőmérséklet

4 Sávkijelzés (I = fűtési idő bekapcsolva)

5 VRT 330 Hét napjai (1 = hétfő, 2 = kedd, 3 = szerda, 4 = csütörtök, 5 = péntek, 6 = szombat, 7 = vasárnap)

6 VRT 330 Aktuális nap megjelölése

Készülék-leírás

A VRT 320 heti fűtési programot tartalmazó szabályozó. A szabályozó két egyéni programmal rendelkezik.

Gyári beállítás:

Fűtésidők 6:00 - 22:00

A VRT 330 heti fűtési programot tartalmazó szobahőmérséklet-szabályozó.

A szabályozó két alapprogrammal (P1 és P2), egy módosítható P3 tömbprogrammal és egy egyéni programmal rendelkezik.

VRT 330 Programbeállítás		Gyári beállítás
	Fűtésidők	
P1	6:00-22:00	héttő-péntek
P2	7:30-22:30	szombat
P3	beállítható (több napra választható) 7:00-22:00	vasárnap
Pi	beállítható (bármely napra egyénileg)	

oldalt

Üzem mód kiválasztása	84
Szabadság-funkciók aktiválása	86
Hőmérséklet módosítása rövid időre	88
Nappali hőmérséklet beállítása	90
Csökkentett hőmérséklet beállítása	90
A pontos idő és hét napjának beállítása	92
VRT 320 Program beállítása	94
VRT 330 Program kiválasztása	96
VRT 330 P3 és Pi program beállítása	98
Telefoni átkapcsolás	100

Szerelés

A szabályozó telepítése

A készüléket csak szakember nyithatja ki és szerelheti fel a 102-104 oldalak ábrái szerint. Ennek során be kell tartani az érvényes biztonsági előírásokat.



A feszültség alatt álló csatlakozó érintése életveszélyes. A készüléken végzett munka előtt kapcsoljuk le az áramellátást, és zárjuk ki az újrabekapcsolás lehetőségét.

Az ezen útmutató figyelmen kívül hagyása, de különösen a hibás kábelezés vagy mechanikai sérülés miatt fellépő kártért felelősséget nem vállalunk.

Kétpontos vagy folyamatos szabályozás (103. oldal)



A Z

A kétpontos szabályozás (gyári beállítás) akkor hasznos, ha a fűtőberendezés teljesítménye lényegesen a számított hőigény felett van (pl. a nagyobb melegvíz-mennyiség érdekében).



A Z

A folyamatos szabályozás akkor ajánlott, ha a fűtőteljesítmény megfelel a számított hőigénynek.

Telefontávkapcsoló bekötése (TEL)

A telefontávkapcsolót a szabályozó TEL kapcsaira kell kötni (l. 104. oldalt). Kérjük, a telefontávkapcsoló szerelési útmutatóját is vegye figyelembe.





Műszaki adatok

Készülék típusa	VRT 320/VRT 330
Üzemi feszültség	max. 30 V
Áramfelvétel	< 10 mA
Menettartalék (óra)	0,5 h
Nappali hőmérséklet tartománya	5 ... 30°C
Csökkentett hőmérséklet tartománya	5 ... 20°C
Kapcsolási különbség (Z)	1 K
Lineáris tartomány (A)	2 K
Csatlakozó vezeték	3x0,75 mm ²
Védettség	IP 30
Védettségi osztály	III
Működési hőmérséklet	+ 5 ... + 50 °C
Tárolási hőmérséklet	- 20 ... + 65 °C
Méreték	111 x 81 x 33 mm
Telefonérintkező aktív	1...3 mA







Návod k obsluze

V místnosti, kde se nachází prostorový regulátor teploty, nechte trvale otevřené ventily topných těles.

Ovládací prvky

-  volba druhu provozu
- OK potvrzení hodnoty, procházení
- + zvýšení hodnoty
- snížení hodnoty
-  nastavení/volba denní teploty
-  nastavení/volba snížené teploty
- P programování intervalů topení
-  nastavení denního času a dne v týdnu
- C návrat/vymazání hodnoty

Přehled údajů na displeji

- 1 aktuální denní čas
- 2 symboly
 -  regulace teploty místnosti podle zadaného programu
 -   - interval topení za snížené teploty
 -   - interval topení
 -  trvalá regulace teploty místnosti na sníženou teplotu
 -  trvalá regulace teploty místnosti podle denní teploty

- ▼ funkce "Party": až do dalšího intervalu topení za snížené teploty se teplota místnosti reguluje podle denní teploty
 - ☑ funkce "Dovolená": po dobu trvání dovolené se teplota místnosti reguluje podle nastavené teploty
 - ☞ krátkodobá změna teplota
- 3 aktuální teplota
 - 4 řadkový ukazatel (I = začátek intervalu topení)
 - 5 VRT 330 dny v týdnu
(1 = pondělí, 2 = úterý, 3 = středa, 4 = čtvrtek, 5 = pátek, 6 = sobota, 7 = neděle)
 - 6 VRT 330 označení aktuálního dne v týdnu

Popis přístroje

VRT 320 je prostorový regulátor teploty místnosti s denním časovým programem. Regulátor disponuje individuálně nastavitelným programem.

z výroby:

intervaly topení 6:00 - 22:00 hod

VRT 330 je prostorový regulátor teploty místnosti s týdenním časovým programem.

Regulátor disponuje 2 základními programy P1 a P2, měnitelným blokovým programem P3 a individuálně nastavitelným programem Pi.

VRT 330 Nastavení programů		z
	intervaly topení	výroby
P1	6:00-22:00 hod	po-pá
P2	7:30-22:30 hod	so
P3	nastavitelný (možnost volby několika dní) 7:00-22:00	ne
Pi	nastavitelný (individuálně na každý den)	

Strana

Volba druhu provozu	84
Aktivace funkce "dovolená"	86
Krátkodobá změna teploty	88
Nastavení denní teploty	90
Nastavení snížené teploty	90
Nastavení denního času a dne v týdnu	92
VRT 320 Nastavení programu	94
VRT 330 Výběr základního programu	96
VRT 330 Nastavení programu P3 a Pi	98
Spínání pomocí telefonního kontaktu	100

Instalace regulátoru

Tento přístroj smí otevřít a podle obrázků na straně 102 až 104 instalovat pouze odborník s příslušným oprávněním. Musí přitom dodržovat existující bezpečnostní předpisy.



Na vodivých kontaktech může při zasažení elektrickým proudem dojít k ohrožení života. Před jakoukoliv manipulací s přístrojem je třeba vypnout přívod proudu a zajistit jej před nechtěným zapnutím.

Za škody, které by byly způsobeny nedodržením pokynů z tohoto návodu, zvláště při nesprávném propojení nebo při mechanickém poškození, nepřebíráme záruku.

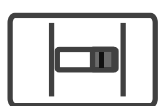
**Dvoupolohová nebo plynulá regulace
(strana 103)**

A Z

Dvoupolohová regulace (nastavení z výroby) je potřebná, jestliže je výkon topného přístroje podstatně vyšší než vypočtená potřeba tepla (např. aby bylo docíleno vyšších dávek teplé vody).

A Z

Plynulá regulace se doporučuje, jestliže topný výkon odpovídá vypočtené potřebě tepla.

Připojení dálkového telefonního spínače (TEL)

Dálkový telefonní spínač se připojí na svorky TEL na regulátoru (viz obrázky na straně 104). Řiďte se návodem k instalaci dálkového telefonního spínače.





Technické údaje

Označení přístroje	VRT 320/VRT 330
Napětí	max. 30 V
Příkon	< 10 mA
Reserva chodu	0,5 h
Rozsah denní teploty	5 ... 30°C
Rozsah snížené teploty	5 ... 20°C
Diference spínání (Z)	1 K
Proporcionální pásmo (A)	2 K
Přívodní vedení	3x0,75 mm ²
Druh ochrany	IP 30
Třída ochrany	III
Provozní teplota	+ 5 ... + 50 °C
Přípustná teplota skladování	- 20 ... + 65 °C
Rozměry	111 x 81 x 33 mm
Vstup TEL	1...3 mA







Exploatare

În camera în care amplasați termostatul deschideți toate robinetele termostatare.

Elemente de comandă

-  selectare regim de funcționare
- OK confirmare valori, derulare meniu
- + mărire valori
- micșorare valori
-  reglare/alegere temperatură de zi
-  reglare/alegere temperatură de noapte
- P programare timpi de încălzire
-  reglare oră și zi a săptămânii
- C revenire/resetare valoare

Privire de ansamblu asupra pupitrului de comandă

- 1 Ora actuală
- 2 Simbol
 -  Termostatul va funcționa după următorul program.
 -   - Temperatură de noapte
 -   - Temperatură de zi (încălzire).
 -  O reglare continuă a temperaturii de cameră, corespunzătoare programului de diminuare.
 -  O reglare continuă a temperaturii de cameră, corespunzătoare programului de zi.

▼ Funcție party: până la primul program de noapte, termostatul va funcționa pe temperatura de zi.

👜 Program de vacanță: puteți regla temperatura pe durata întregului concediu.

👉 Scurtă modificare a temperaturii.

3 Temperatura actuală

4 LED-uri indicatoare (I = pornire încălzire)

5 VRT 330 Zi săptămână (1 = luni, 2 = marți, 3 = miercuri, 4 = joi, 5 = vineri, 6 = sâmbătă, 7 = duminică)

6 VRT 330 Indică ziua actuală a săptămânii

Descriere aparat

VRT 320 este un termostat de cameră cu programare săptămânală. Regulatorul dispune de un program individual.

Reglare din fabrică

Timpi de încălzire 6:00 - 22:00

VRT 330 este un termostat de cameră cu programare săptămânală.

Regulatorul dispune de 2 programe de bază P1 și P2, un program bloc ce poate fi modificat P3 și un program individual Pi.

VRT 330 Reglarea programelor		Reglare din fabrică
	Timpi de încălzire	
P1	6:00-22:00	Lu-Vi
P2	7:30-22:30	Sâ
P3	reglabil (pentru mai multe zile ale săptămânii) 7:00-22:00	Du
Pi	reglabil (individual pentru fiecare zi a săptămânii)	

Pagină

Selectarea regimului de funcționare	.84
Activarea funcției concediu	.86
Scurtă modificare a temperaturii	.88
Reglarea temperaturii de zi	.90
Reglarea temperaturii de noapte	.90
Reglarea orei și a zilei	.92
VRT 320 Modificarea programelor	.94
VRT 330 Selectarea programelor de bază	.96
VRT 330 Modificarea programelor P3 și Pi	.98
Cuplarea prin intermediul telefonului	.100

Instalare

Montarea regulatorului

Aparatul poate fi deschis și montat conform instrucțiunilor de la pag. 102-104, numai de către persoane autorizate. În acest sens trebuie să urmăriți cu atenție instrucțiunile de siguranță.



Lucrați cu grijă la elementele sub tensiune ale aparatului. Înainte de orice intervenție la aparat, deconectați-l de la rețeaua de curent, iar la repornire asigurați-vă că totul este în ordine.

Pentru defecțiuni rezultate în urma nerespectării acestor instrucțiuni (de ex. racorduri greșite, ori deteriorări mecanice) nu ne asumăm nici o răspundere.

Reglare bipozițională sau continuă (pagina 103)

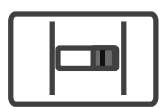

A Z

Reglarea bipozițională (a producătorului) este necesară când puterea aparatului de încălzire se situează clar peste necesarul termic calculat (de ex. pentru atingerea unei puteri mai ridicate de încălzire a apei calde).



A Z

Reglarea continuă se recomandă când puterea de încălzire corespunde necesarului de căldură calculat.

Racord telefonic (TEL)

Racordul telefonic se realizează la clemenele TEL ale regulatorului (vezi fig. de la pag. 104).

Parcurgeți și instrucțiunile de instalare ale aparatului telefonic.





Date tehnice

Descriere aparat	VRT 320/VRT 330
Tensiune de lucru	max. 30 V
Consum de curent	< 10 mA
Rezervă de timp	0,5 h
Domeniu pt. temperatura de zi	5 ... 30°C
Domeniu pt. temp. de noapte	5 ... 20°C
Diferență de cuplare (Z)	1 K
Domeniul de proporționalitate (A)	2 K
Cablu de racord	3x0,75 mm ²
Tip siguranță	IP 30
Clasă de protecție	III
Temperatură de lucru	+ 5 ... + 50 °C
Temp. de depozitare admisă	- 20 ... + 65 °C
Dimensiuni	111 x 81 x 33 mm
Intrare TEL	1...3 mA







Rukovanje

U prostoriji u kojoj se nalazi regulator temperature uvijek ostavite potpuno otvorene sve ventile na radiatorima.

Elementi za rukovanje

-  Bodabrati način rada
- OK vrijednost potvrditi, listati dalje
- + vrijednost povećati
- vrijednost smanjiti
-  podesiti / odabrati dnevnu temperaturu
-  podesiti / odabrati sniženu temperaturu
- P programirati vremena grijanja
-  podesiti vrijeme i dan u tjednu
- C vratiti se natrag / resetirati vrijednost

Pregled prikaza na displeju

- 1 aktualno vrijeme
- 2 simboli
 -  sobna temperatura se regulira preko unesenog programa
 -   - vrijeme snižene temperature
 -   - vrijeme grijanja
 -  stalno reguliranje temperature u prostorijama prema sniženoj temperaturi
 -  stalno reguliranje temperature u prostorijama prema dnevnoj temperaturi

- ▼ funkcija "party": do slijedećeg vremena snižene temperature će se temperatura u prostorijama regulirati prema dnevnoj temperaturi
 - 🗑️ program godišnjeg odmora: tijekom godišnjeg odmora će se temperatura u prostorijama regulirati prema podešenoj temperaturi
 - 👉 kratkotrajna promjena temperature
- 3 aktualna temperatura
 - 4 linijski prikaz (I = vrijeme grijanja uključeno)
 - 5 VRT 330 dani u tjednu
(1=po, 2=ut, 3=sr, 4=če, 5=pe, 6=su, 7=ne)
 - 6 VRT 330 oznaka aktualnog dana u tjednu

Opis uređaja

VRT 320 je regulator temperature u prostorijama s dnevnim programom grijanja. Regulator raspolaže s jednim individualno podesivim programom.

Tvornička podeš.:

Vremena grijanja 6:00 - 22:00 sati

VRT 330 je regulator temperature u prostorijama s tjednim programom grijanja.

Regulator raspolaže s 2 osnovna programa - P1 i P2, jednim promjenjivim blok programom P3 te jednim individualno podesivim programom Pi.

VRT 330 Pregled vremenskih programa		Tvornička podeš.
	Vremena grijanja	
P1	6:00-22:00 sati	pon-pet
P2	7:30-22:30 sati	sub
P3	namjestiv (mogućnost odabira za više dana) 7:00-22:00 sati	ned
Pi	namjestiv (individualno za svaki dan)	

Stranica

Odabrati način rada	.84
Aktivirati funkciju godišnjeg odmora	.86
Kratkotrajno promijeniti temperaturu	.88
Podesiti dnevnu temperaturu	.90
Podesiti sniženu temperaturu	.90
Podesiti vrijeme i dan u tjednu	.92
VRT 320 Podesiti program	.94
VRT 330 Odabrati osnovni program	.96
VRT 330 Podesiti program P3 i Pi	.98
Upravljanje preko daljinske telefonske sklopke	100

Instaliranje regulatora

Uređaj smije otvoriti i prema slikama na stranicama od 102 do 104 instalirati samo ovlašteni stručnjak. Pritom se treba pridržavati postojećih propisa o sigurnosti.



Opasnost po život uslijed strujnog udara iz priključaka koji su pod naponom. Prije radova na uređaju treba isključiti dovod struje i osigurati se da ne dođe do ponovnog uključivanja.

Ne preuzimamo odgovornost za štete koje bi nastale uslijed nepridržavanja ovih uputa, a posebice za one nastale uslijed pogrešnog ožičenja ili mehaničkog oštećenja.

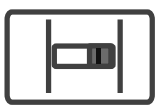
Regulacija s dvije točke ili kontinuirana regulacija (stranica 103)

A Z

Regulacija s dvije točke (podešena u tvornici) je potrebna u slučajevima kad je učin uređaja za grijanje znatno veći od proračunate potrebe za toplinom (npr. za postizanje većeg učina pripreme tople vode).



A Z

Kontinuirana regulacija preporučuje se u slučajevima kad učin grijanja odgovara proračunatoj potrebi za toplinom.

Priključivanje daljinske telefonske sklopke (TEL)

Daljinska telefonska sklopka se priključuje na stezaljke regulatora TEL (vidi sliku na stranici 104).

Pridržavajte se uputa za instaliranje daljinske telefonske sklopke.





Tehnički podaci

Oznaka uređaja	VRT 320/VRT 330
Pogonski napon	Maks. 30 V
Primljena struja	< 10 mA
Hodna reserva	0,5 h
Područje dnevne temperature	5 ... 30°C
Područje noćne temperature	5 ... 20°C
Uklopna razlika (Z)	1 K
Proporcionalno područje (A)	2 K
Priključni vodovi	3x0,75 mm ²
Vrsta zaštite	IP 30
Klasa zaštite	III
Pogonska temperatura	+ 5 ... + 50 °C
Dozvoljena temperatura skladištenja	- 20 ... + 65 °C
Dimenzije	111 x 81 x 33 mm
Ulaz telefon	1...3 mA







Obsluha

V miestnosti, v ktorej sa nachádza regulátor vnútornej teploty nechajte, vždy na vykurovacích telesách otvorené všetky ventily.

Obslužné prvky

-  Voľba prevádzkového režimu
- OK Potvrdenie hodnoty, ďalšie listovanie
- + Zvýšenie hodnoty
- Zníženie hodnoty
-  Nastavenie / voľba dennej teploty
-  Nastavenie / voľba zníženej teploty
- P Programovanie vykurovacích dôb
-  Nastavenie dňa v týždni a času
- C Krok späť / návrat hodnoty

Prehľad symbolov displeja

- 1 Aktuálny čas
- 2 Symboly
 -  Teplota v miestnosti sa riadi zadaným programom.
 -   - Znížená teplota
 -   - Doba vykurovania
 -  Stála regulácia teploty v miestnosti v závislosti od zníženej teploty.
 -  Stála regulácia teploty v miestnosti v závislosti od dennej teploty.

▼ Funkcia "Party": až k nasledujúcemu času zníženia sa teplota v miestnosti reguluje v závislosti od dennej teploty.

👛 Dovolenkový program: Počas trvania Vašej dovolenky sa teplota v miestnosti riadi adekvátne nastavenou teplotou.

👉 Krátkodobá zmena teploty.

3 Aktuálna teplota

4 Zobrazenie kurzora

(I = Čas vykurovania zapnutý)

5 VRT 330 Dni v týždni

(1 = Pondelok, 2 = Utorok, 3 = Streda, 4 = Štvrtok, 5 = Piatok, 6 = Sobota, 7 = Nedeľa)

6 VRT 330 Označenie aktuálneho dňa v týždni

Popis zariadenia

VRT 320 je regulátor vnútornej teploty s denným vykurovacím programom.

Regulátor disponuje dvoma individuálne nastaviiteľným programom. Vo výr. Závode:

Vykurovacie doby 6: 00- 22: 00 hod.

VRT 330 je regulátor vnútornej teploty s týždenným vykurovacím programom. Regulátor disponuje dvoma základnými programami P1 a P2, premenlivým blokovým programom P3 a individuálne nastaviteľným programom Pi.

VRT 330 Nastavenie programov		vo výr. závode
	Vykurovacie doby	
P1	6:00-22:00 hod.	Po - Pi
P2	7:30-22:30 hod.	So
P3	nastaviteľné (voliteľné pre viac dní) 7:00-22:00 hod.	Ne
Pi	nastaviteľné (individuálne pre každý deň)	

Strana

Voľba typu prevádzky	84
Krátkodobé prestavenie teploty	86
Aktivácia dovolenkovej funkcie	88
Nastavenie dennej teploty	90
Nastavenie zníženej teploty	90
Nastavenie dňa v týždni a času	92
VRT 320 Nastavenie programu	94
VRT 330 Výber základného programu	96
VRT 330 Nastavenie programu P3 a	98
Zapnutie prostredníctvom telef. kontaktu ...	100

Montáž

Inštalácia regulátora

Toto zariadenie smie otvoriť len vyškolený odborník a inštalovať v súlade s vyobrazeniami na stranách 102 až 104. Pritom je potrebné dodržiavať nasledujúce bezpečnostné predpisy.



Ohrozenie života úderom elektrického prúdu na prívodných častiach vedúcich elektrické napätie. Pred prácami na zariadení je potrebné odpojiť ho od prívodu elektrickej energie a zaistiť pred opätovným zapnutím.

Za škody vzniknuté v dôsledku nerešpektovania tohto návodu, zvlášť v dôsledku nesprávneho pripojenia vodičov alebo mechanického poškodenia, nepreberáme žiadnu záruku.

Dvojbodová alebo plynulá regulácia (strana 103)



A Z

Dvojbodová regulácia (výrobné nastavenie) je nevyhnutné, keď výkon vykurovacieho agregátu sa zreteľne nachádza nad dosiahnutou spotrebou tepla (napr. pre dosiahnutie vyššieho výkonu TÚV).



A Z

Plynulá regulácia sa odporúča vtedy, keď vykurovací výkon zodpovedá dosiahnutej spotrebe tepla.

Pripojenie telefónneho diaľkového spínača (TEL)

Telefonický diaľkový spínač sa pripojí na svorky TEL regulátora (pozri vyobrazenie na strane 104). Rešpektujte prosím návod na inštaláciu telefónneho diaľkového spínača.





Technické údaje

Označenie zariadenia	VRT 320/VRT 330
Prevádzkové napätie	max 30 V
Odber prúdu	< 10 mA
Rezerva chodu	0,5 h
Rozsah dennej teploty	5 ... 30°C
Rozsah zníženej teploty	5 ... 20°C
Diferencia zapojenia (Z)	1 K
Pásmo úmernosti (A)	2 K
Prípojné vedenia	3x0,75 mm ²
Spôsob ochrany	IP 30
Trieda ochrany	III
Prevádzková teplota	+ 5 ... + 50 °C
Príp. teplota skladovania	- 20 ... + 65 °C
Rozmery	111 x 81 x 33 mm
Vstup TEL	1...3 mA







Kullanım kılavuzu

Oda termostatınızın bulunduğu odadaki bütün radyatör vanalarını daima sonuna kadar açık tutunuz.

Kumanda elemanları

-  İşletme türü seçimi
- OK Seçilen değeri onaylama, devam etme
- + Değeri yükseltme
- Değeri azaltma
-  Gündüz konumu sıcaklık ayarı / seçimi
-  Gece konumu sıcaklık ayarı / seçimi
- P Isıtma zamanlarını programlama
-  Aktüel saat ve gün ayarı
- C Geri dönüş/değeri silmek

Ekran genel görünüm

- 1 Aktüel saat
- 2 Semboller
 -  Oda sıcaklığı, ayarlanmış bir programa göre düzenlenir
 -   - Program - gece konumunda
 -   - Program - gündüz konumunda
 -  Oda sıcaklığının sürekli olarak seçilen gece konumu sıcaklığına göre ayarlanması
 -  Oda sıcaklığının sürekli olarak seçilen gündüz konumu sıcaklığına göre ayarlanması

▼ Parti fonksiyonu: Oda sıcaklığı bir sonraki gece konumu zamanına kadar, seçilen gündüz konumu sıcaklığına göre ayarlanmaktadır.

🗑️ Tatiliniz boyunca oda sıcaklığı, seçtiğiniz sıcaklıklara göre ayarlanacaktır.

👉 Kısa süre için sıcaklık değiştirilmesi.

3 Aktüel oda sıcaklığı

4 Gösterge (I = Program ısıtma zamanı başlangıcı)

5 VRT 330 Günler

(1 = Pazartesi, 2 = Salı, 3 = Çarşamba, 4 = Perşembe, 5 = Cuma, 6 = Cumartesi, 7 = Pazar)

6 VRT 330 Aktüel günü göstergesi

Cihazın tarifi

VRT 320, günlük ısıtma programı olan bir oda termostatıdır.

Fabrika ayarı

Isıtma saatleri

Saat 6.00-22.00

VRT 330 cihazı haftalık programlı bir oda termostatıdır. Bu oda termostati P1 ve P2 olmak üzere 2 ana programa sahiptir. Ayrıca değiştirilebilen bir blok program P3 ve isteğe bağlı ayarlanabilen program Pi mevcuttur.

VRT 330 Programların ayarlanması		Fabrikasyon
	Isıtma saatleri	
P1	Saat 6:00-22:00	Pzt.-Cu
P2	Saat 7:30-22:30	Cts
P3	ayarlanabilir (birden fazla gün için aynı program zamanları) Saat 7:00-22:00	Pz.
Pi	ayarlanabilir (kullanıcı isteğine bağlı olarak her gün için ayrı program zamanları)	

Sayfa

İşletme türü seçimi	84
Tatil fonksiyonunu çalıştırma	86
Kısa bir süre için sıcaklık değiştirilmesi	88
Gündüz konumu sıcaklığının ayarlanması	90
Gece konumu sıcaklığının ayarlanması	90
Aktüel saat ve günün ayarlanması	92
VRT 320 Ana program seçimi	94
VRT 330 Ana program seçimi	96
VRT 330 P3 ve Pi programlarının ayarlanması	98
Telefon bağlantısıyla kumanda	100

Termostatın, radyo alıcısının montajı

Bu cihaz sadece Vaillant teknik servis elemanları tarafından çalıştırılabilir ve 102-104 sayfalardaki şekillerde gösterilen talimatlara uymak suretiyle Vaillant yetkili satıcıları tarafından monte edilebilir. Bu işlemler sırasında emniyet talimatlarına dikkat edilmelidir.

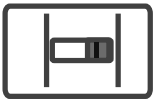

Elektrik gerilimi yüklü bağlantılardan elektrik çarpması sonucu hayati tehlike mevcuttur. Cihaz üzerinde çalışmaya başlamadan önce elektrik girişini kesiniz ve tekrar açılmamasını emniyet altına alınız.

Çift nokta veya analog ayar (Sayfa 103)**A Z**

Çift nokta ayarı (fabrikasyon ayarı) ısıtıcı cihazın gücü, hesaplanmış ısı gereksiniminin belirgin bir şekilde üstünde olduğunda gereklidir (örn. daha büyük bir sıcak kullanma suyu gücü sağlamak için).

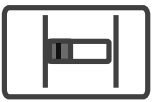
**A Z**

Analog ayar, ısıtma gücü hesaplanan ısı gereksinimine uygun olduğunda tavsiye edilmektedir.

Telefonla uzaktan kumanda bağlantısı (TEL)





Telefonla uzaktan kumanda cihazı oda termostatu üzerindeki TEL klemenslerine bağlanacaktır (bkz. Şekil Sayfa 104). Telefonla uzaktan kumanda cihazının montaj kılavuzundaki talimatlara dikkat ediniz.

Teknik veriler







Cihaz tipi	VRT 320/VRT 330
İşletme gerilimi	max. 30 V
Çekilen akım	< 10 mA
Çalışma rezervi (saat)	0,5 h
Gündüz konumu sıcaklık ayar aralığı	5 ... 30°C
Gece konumu sıcaklık ayar aralığı	5 ... 20°C
Devreye girme sıcaklık farkı (Z)	1 K
Orantı aralığı (A)	2 K
Bağlantı kabloları	3x0,75 mm ²
Koruma türü	IP 30
Koruma sınıfı	III
İşletme sıcaklığı	+ 5 ... + 50 °C
Müsaade edilen depolama sıcaklığı	- 20 ... + 65 °C
Ölçüleri	111 x 81 x 33 mm
Giriş TEL	1...3 mA

В помещении, где находится комнатный термостат, должны быть полностью открыты или сняты все термостатические вентили на отопительных приборах.

Кнопки на панели управления

-  Выбор режима работы
- OK Сохранить данные, пролистать меню
- + Увеличение значения
- Уменьшение значения
-  Выбор / установка дневной температуры помещения
-  Выбор / установка ночной температуры помещения
- P Задание отрезков времени для программы
-  Установка времени и дня недели
- C Возврат назад / отказ от изменения

Элементы дисплея

- 1 Текущее время
- 2 Символы
 -  Температура помещения изменяется по заданной программе.
 -   - Ночной режим
 -   - Дневной режим
 -  Постоянное поддержание заданной ночной температуры
 -  Постоянное поддержание заданной дневной температуры

⚠ Функция "Встреча": До следующего интервала отопления с ночной температурой помещения поддерживается дневная температура.

🧳 Программа "Отпуск": Во время Вашего отпуска поддерживается специально заданная для этого температура помещения.

👉 Кратковременное изменение температуры

3 Фактическая температура

4 Столбчатый индикатор (I=дневной режим)

5 VRT 330 Дни недели

(1=Пн, 2=Вт, 3=Ср, 4=Чт, 5=Пт, 6=Сб, 7=Вс)

6 VRT 330 Указатель текущего дня недели

Описание прибора

VRT 320 является комнатным термостатом с программированием на сутки.

Временные отрезки 6:00-22:00 час

VRT 330 является комнатным термостатом с недельным программированием.

Регулятор имеет 2 основных программы P1 и P2, изменяемую блок-программу P3 и индивидуально задаваемую программу Pi.

VRT 330 Установки отрезков программы		Станд. значение
	Временные отрезки	
P1	6:00-22:00 час	Пн-Пт
P2	7:30-22:30 час	Сб
P3	Изменяемая (для нескольких дней) 7:00-22:00 час	Вс
Pi	Изменяемая (для каждого дня отдельно)	

Страница

Выбор режима работы	84
Включение программы "Отпуск"	86
Тратковременная перестановка температуры	88
Установка дневной температуры	90
Установка ночной температуры	90
Установка времени и дня недели	92
VRT 320 Задание программ	94
VRT 330 Выбор основной программы	96
VRT 330 Задание программ P3 и Pi	98
Управление через телефонный контактор	100

Монтаж

Монтаж комнатного термостата

Этот прибор должен открываться и монтироваться только лицензированным специалистом в соответствии с рисунками на стр. 102...104. При этом должны соблюдаться действующие местные нормы и предписания, касающиеся монтажа и эксплуатации электрооборудования.



Опасность поражения электротоком при прикосновении к токоведущим частям! Перед началом работ отключите установку от электросети и защитите её от несанкционированного включения.

За повреждения и ущерб, вызванные несоблюдением данной инструкции, в том числе из-за ошибочного подключения и механических повреждений, завод-изготовитель ответственности не несёт.

Выбор двухпозиционного или непрерывного регулирования (стр. 103)



A Z

Двухпозиционно регулирование (заводская установка) требуется в том случае, если мощность нагревательного устройства заводом превышает расчетную отопительную нагрузку (например, чтобы обеспечить повышенную мощность по нагреву воды для горячего водоснабжения).



A Z

Непрерывно регулирование рекомендуется тогда, когда мощность нагревательной системы соответствует отопительной нагрузке.

Подключение телефонного контактора

Телефонный контактор подключается к клеммат TEL термостата (См. рис. на стр. 104). Просьба соблюдать инструкции по монтажу телефонного контактора.

Технические данные





Обозначение прибора	VRT 320/VRT 330
Напряжение питания	Макс. 30 В =
Ток контактов	< 10 mA
Максимальный ток контактов:	5 A/250 V~ cos φ=1
Запас хода	0,5 ч
Диапазон дневных температур помещения	5 ... 30°C
Диапазон ночных температур помещения	5 ... 20°C
Зона нечувствительности (Z)	1 К
Прдлы пропорционального ргулирования (A)	2 К
Подключаемые проводники	3x0,75 mm ²
Вид защиты	IP 30
Класс защиты	III
Температура эксплуатации	+ 5 ... + 50 °C
Допустимая температура хранения	- 20 ... + 65 °C
Размеры	111 x 81 x 33 mm









Operação

Deixe completamente abertas, todas as válvulas do aquecedor da divisão em que se encontra o regulador de temperatura ambiente.

Elementos de operação

-  Seleccionar modo de funcionamento
- OK Confirmar valor, continuar a selecção
- + Aumentar o valor
- Reduzir o valor
-  Regular/seleccionar temperatura de dia
-  Regular/seleccionar redução de temperatura
- P Programar períodos de aquecimento
-  Programar a hora e o dia da semana
- C Repor valor anterior/ voltar atrás

Panorama geral do mostrador

- 1 Hora actual
- 2 Símbolos
 -  A temperatura ambiente é regulada de acordo com o programa seleccionado.
 -   - Período de redução de temperatura
 -   - Período de aquecimento
 -  Regulação permanente da temperatura ambiente de acordo com a redução de temperatura programada.
 -  Regulação permanente da temperatura de acordo com a temperatura de dia programada.

▼ Função Party: até ao início do período de aquecimento seguinte a temperatura ambiente será regulada de acordo com a temperatura de dia programada.

🧳 Programa de férias: durante o período das suas férias a temperatura ambiente será regulada de acordo com a temperatura programada.

👉 Alteração temporária da temperatura

3 Temperatura actual

4 Indicador de barra (I = Período de aquecimento ligado)

5 VRT 330 - dias da semana

(1= 2ª feira, 2= 3ª feira, 3=4ª feira, 4= 5ª feira, 6ª feira, 6= sábado, 7= domingo)

6 VRT 330 - Marcação do dia de semana actual

Descrição do modelo VRT320

O VRT 320 é um regulador de temperatura ambiente com programa de aquecimento diário. Dispõe de um programa regulável. Configuração de fábrica:

Período de aquecimento: 06:00h - 22:00h

Descrição do modelo VRT330

O VRT 330 é um regulador de temperatura ambiente com programa de aquecimento semanal. Dispõe de 2 programas de base P1 e P2, de um programa de bloco alterável P3, e de um programa individualmente regulável Pi.

VRT 330 Regulação dos programas		De fábrica
	Períodos de aquecimento	
P1	06:00-22:00 h	2 ^a a 6 ^a F
P2	07:30-22:30 h	Sab.
P3	Regulável (seleccionável para vários dias) 07:30-22:00 h	Dom.
Pi	Regulável (para cada dia individualmente)	

Página

Seleccionar tipo de funcionamento.....	84
Activar função de férias	86
Alterar temperatura temporariamente.....	88
Programar temperatura	90
Programar redução de temperatura	90
Programar hora e dia da semana.....	92
VRT 320 - Efectuar programa	94
VRT 330 - Seleccionar programa base	96
VRT 330 - Efectuar programa P3 e Pi.....	98
Activar através de contacto telefónico remoto	100

Montagem

Instalação do regulador

Este aparelho somente poderá ser instalado por um técnico especializado, conforme os esquemas apresentados nas páginas 102 a 104 e tendo em atenção os regulamentos de segurança.



Perigo de vida por descarga eléctrica nos terminais condutores de corrente. Antes de proceder a qualquer operação no aparelho, desligar a alimentação de energia e precaver-se contra uma eventual ligação acidental.

Não será aceite qualquer responsabilidade da nossa parte, por danos originados pelo não seguimento destas instruções, em especial devido a erros de cablagem e danificação mecânica.

Regulação binária ou contínua (página 103)

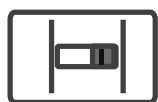

A Z

A regulação binária (configuração de fábrica) é necessária quando a potência do aquecedor é significativamente superior à necessidade de calor calculada. (por exemplo para alcançar uma maior capacidade de aquecimento de água).



A Z

A regulação contínua é aconselhada, quando a potência do aquecedor equivale à necessidade de calor calculada.

Conectar o controlo remoto via telefone (TEL)

A ligação de saída do controlo remoto via telefone é conectada no borne TEL do regulador (ver esquema nas páginas 104).

Por favor tenha em atenção as instruções de instalação do controlo remoto via telefone.

Dados Técnicos

Designação do aparelho	VRT 320/VRT 330
Voltagem de funcionamento	Max. 30 V
Consumo de energia	< 10 mA
Reserva de funcionamento do relógio	0,5 h
Limites de temperatura	5 ... 30°C
Limites da redução de temperatura	5 ... 20°C
Diferencial de comutação (Z)	1 K
Limite proporcional (A)	2 K
Cabos de ligação	3x0,75 mm ²
Tipo de segurança	IP 30
Classe de segurança	III
Temperatura de funcionamento	+ 5 ... + 50 °C
Temperatura de armazenagem	- 20 ... + 65 °C
Dimensões gap	111 x 81 x 33 mm
Corrente nominal TEL	1 ... 3 mA

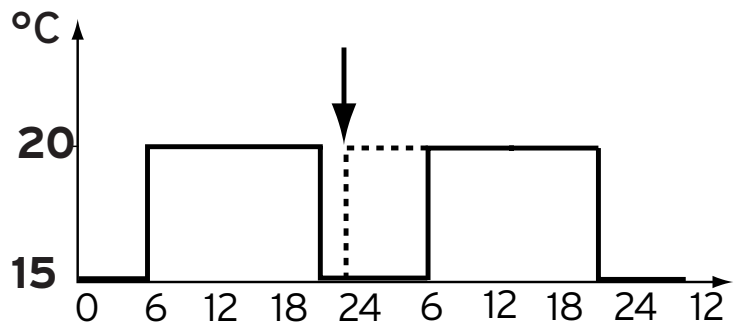
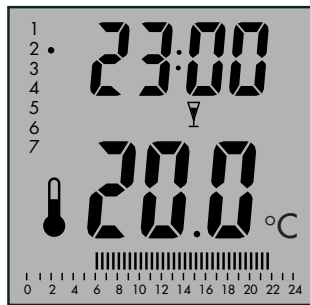
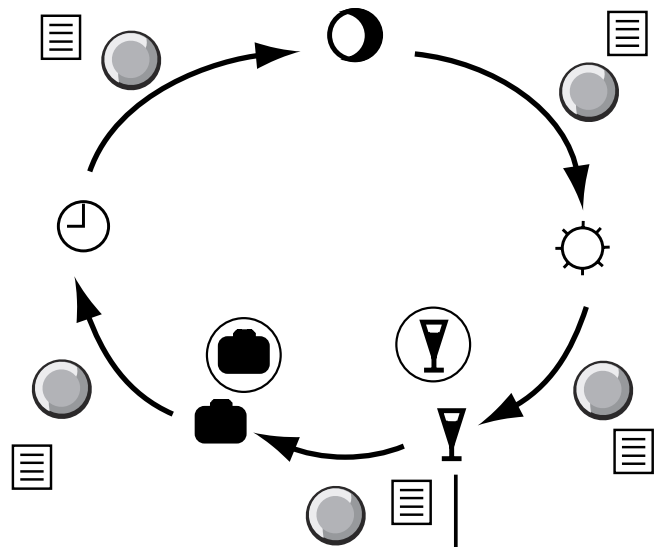
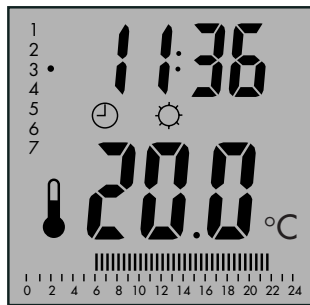
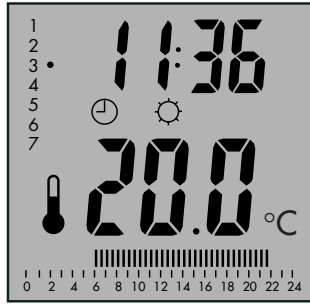

DE	Betriebsart wählen
GB	Choose the operating mode
FR	Choix du mode de fonctionnement
ES	Seleccionar modo de funcionamiento
IT	Impostazione del modo operativo
NL	Bedrijfsfunctie kiezen
DK	Valg af driftsart
PL	Wybór trybu pracy
HU	Üzem mód kiválasztása
CZ	Volba druhu provozu
RO	Selectarea regimului de funcționare
HR	Odabirati način rada
SK	Voľba prevádzkového režimu
TR	İşletme türü seçimi
RUS	Выбор режима работы
PT	Seleccionar tipo de funcionamento

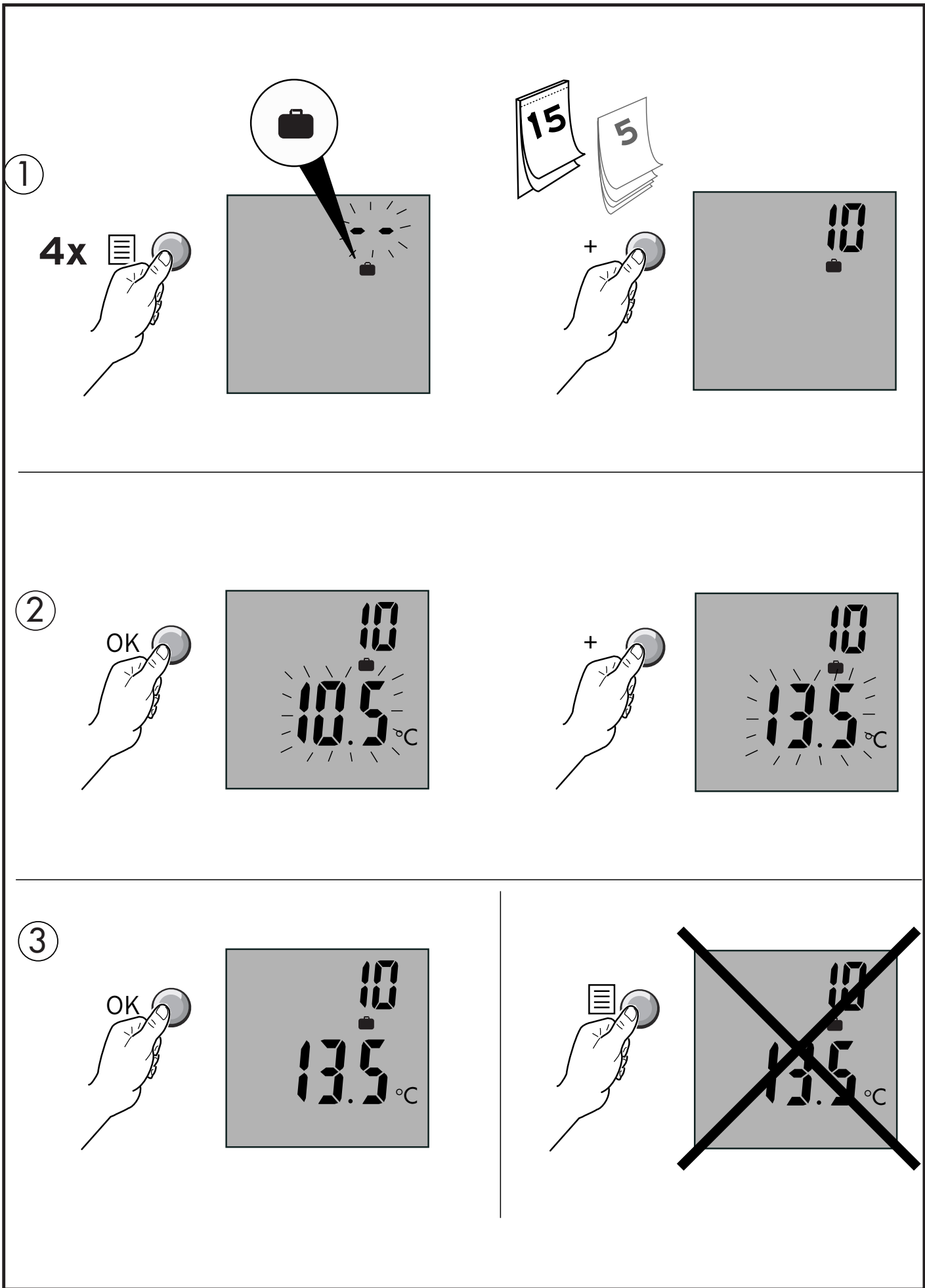

DE	Urlaubsfunktion aktivieren
GB	Activate the holiday program
FR	Activer la fonction congés
ES	Activar funcionamiento en vacaciones
IT	Impostazione programma vacanze
NL	Vakantieprogramma activeren
DK	Aktivering af feriedrift
PL	Aktywacja funkcji urlopowej
HU	Szabadság-funkciók aktiválása
CZ	Aktivace funkce "dovolená"
RO	Activarea funcției concediu
HR	Aktivirati funkciju godišnjeg odmora
SK	Aktivácia dovolenkovej funkcie
TR	Tatil foksiyonunu çalıştırma
RUS	Включение программы "Отпуск"
PT	Activar função de férias

1

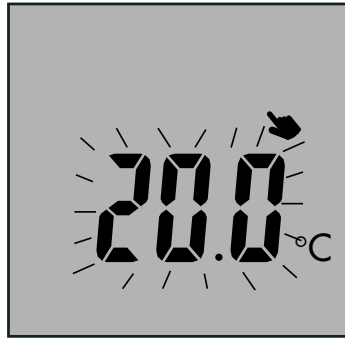
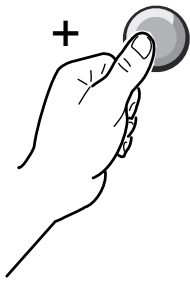

2a

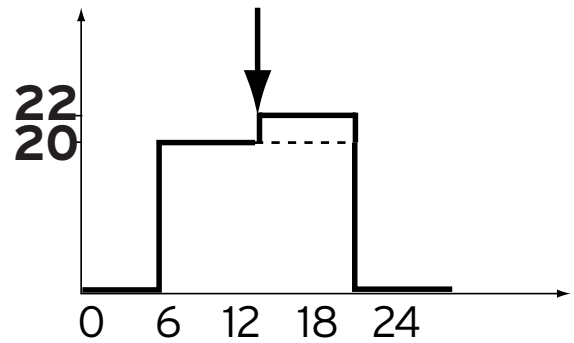
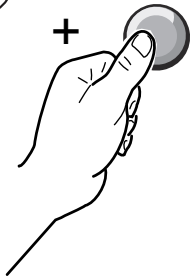

2b

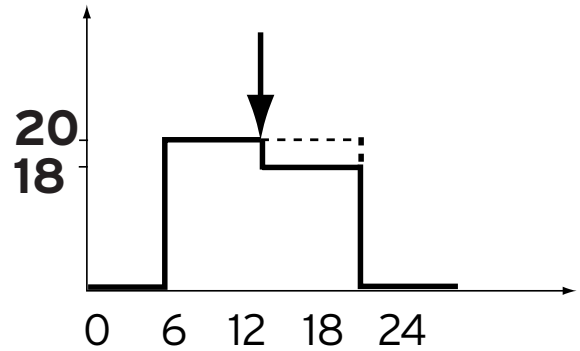
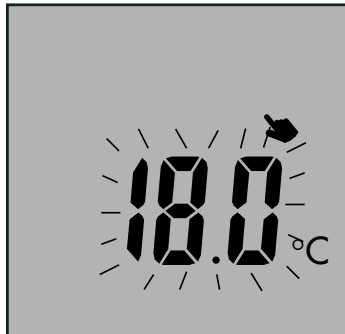
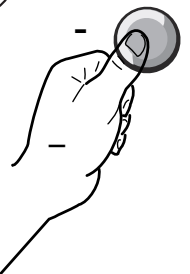

3

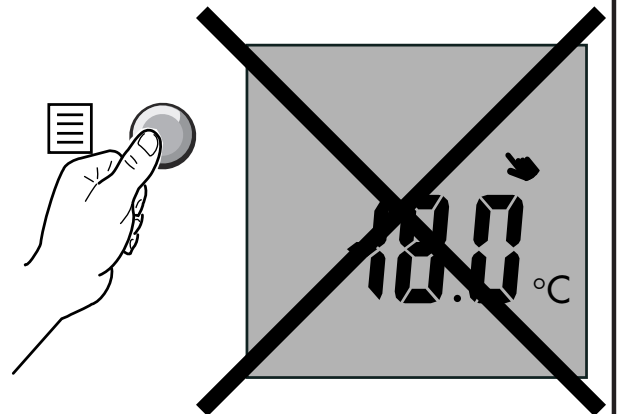
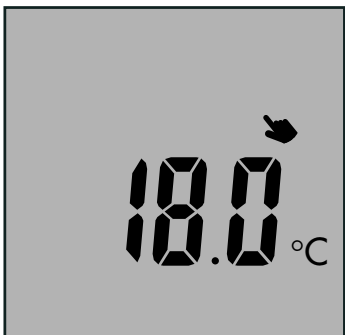

DE	Temperatur kurzfristig verstellen
GB	Temporary change of temperature setting
FR	Brève modification de la température
ES	Variar temperatura a corto plazo
IT	Modifica temporanea temp. ambiente
NL	Kamertemperatuur kortstondig wijzigen
DK	Midlertidig ændring af temperatur
PL	Krótkotrwałe przestawienie temperatury
HU	Hőmérséklet módosítása rövid időre
CZ	Krátkodobá změna teploty
RO	Scurtă modificare a temperaturii
HR	Kratkotrajno promijeniti temperaturu
SK	Krátkodobé prestavenie teploty
TR	Kısa bir süre için sıcaklık değiştirilmesi
RUS	Кратковременная перестановка температуры
PT	Alterar temperatura temporariamente

☀ °C

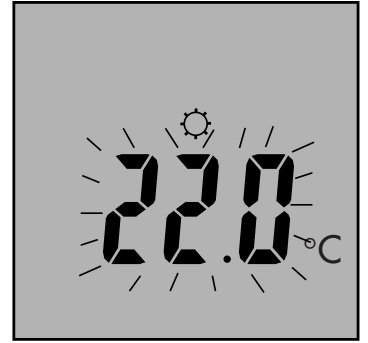
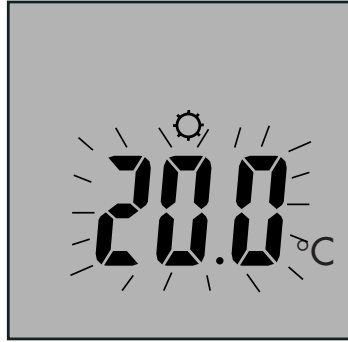
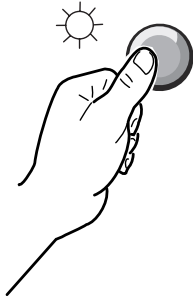

☾ °C

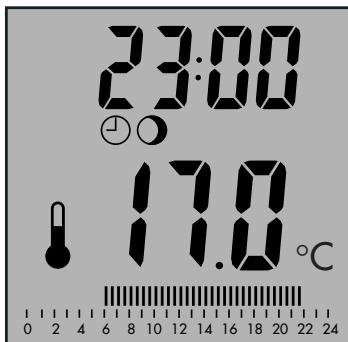
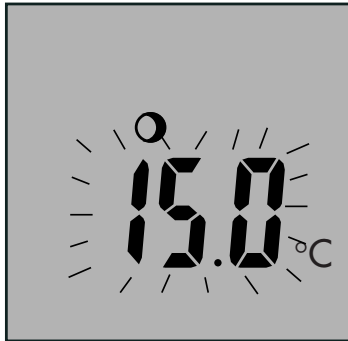
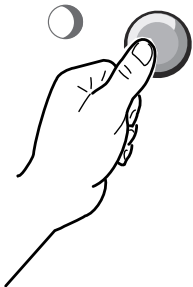

DE	Tag-/Absenktemperatur einstellen
GB	Adjust the day / night temperature
FR	Réglage température jour / d'abaissement
ES	Ajustar temperatura diurna / descenso de temperatura
IT	Impostazione della temperatura diurna/attenuata
NL	Dagtemperatuur / Verlagingstemperatuur instellen
DK	Indstilling af dagtemperatur/nattemperatur
PL	Ustawienie temperatury dziennej/obniżonej
HU	Nappali hőmérséklet beállítása "Csökkentett hőmérséklet" beállítása
CZ	Nastavení denní / snížené teploty
RO	Reglarea temperaturii de zi / de noapte
HR	Podesiti dnevnu / sniženu temperaturu
SK	Nastavenie dennej / zníženej teploty
TR	Gündüz sıcaklığının ayarlanması Gece sıcaklığının ayarlanması
RUS	Установка дневной / ночной температуры помещения
PT	Programar temperatura / redução de temperatura

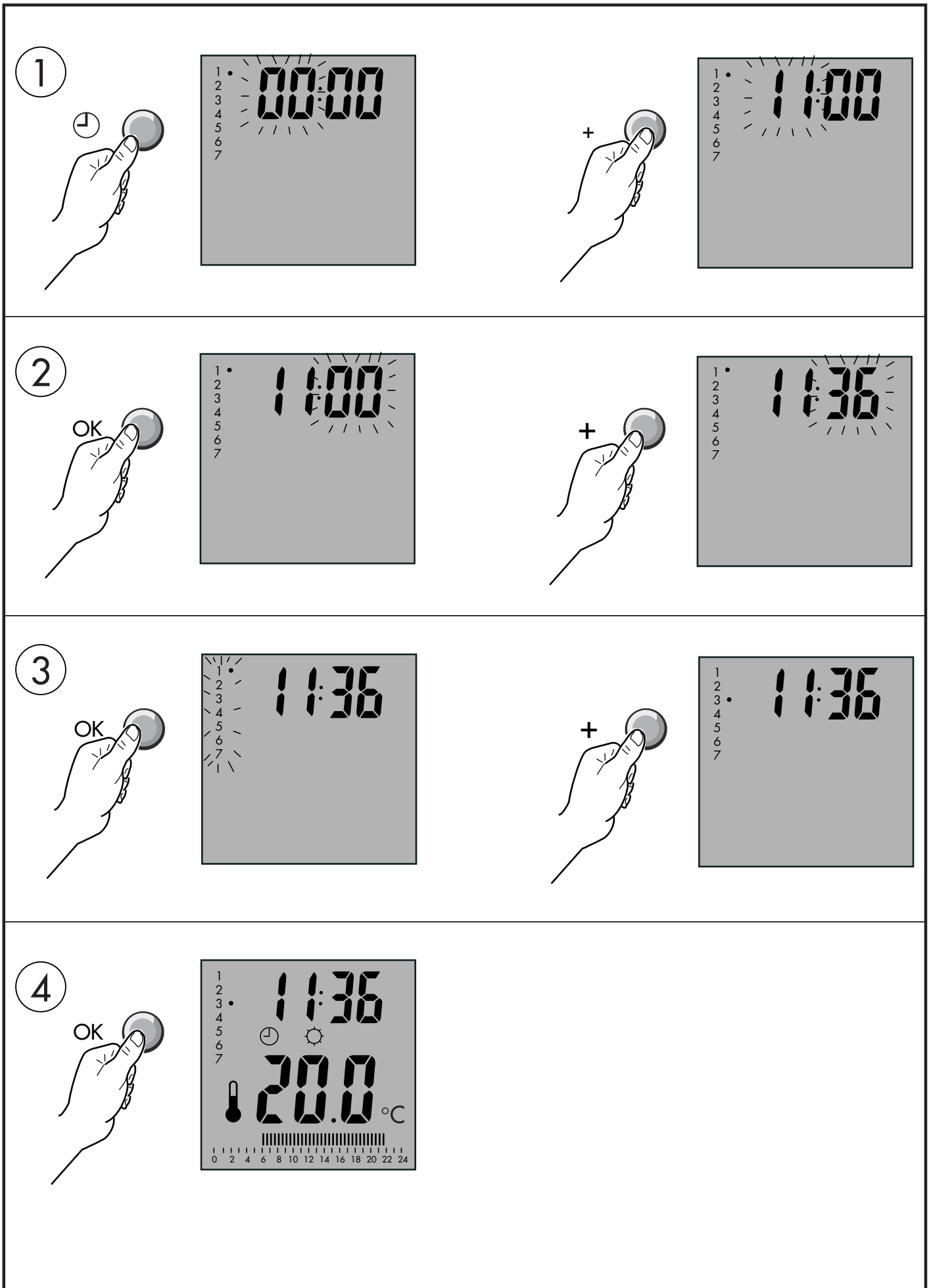

DE	Uhrzeit und Wochentag einstellen
GB	Set the date and time
FR	Réglage heure et jour
ES	Ajustar el tiempo horario y el día de la semana
IT	Impostazione ora e giorno della settimana
NL	Tijd en dag van de week instellen
DK	Indstilling af klokkeslæt og ugedag
PL	Ustawienie godziny i dnia tygodnia
HU	A pontos idő és hét napjának beállítása
CZ	Nastavení denního času a dne v týdnu
RO	Reglarea orei și a zilei săptămânii
HR	Podesiti vrijeme i dan u tjednu
SK	Nastavenie dňa v týždni a času
TR	Saatın ve haftanın gününün ayarlanması
RUS	Установка времени и дня недели
PT	Programar hora e dia da semana

1



2

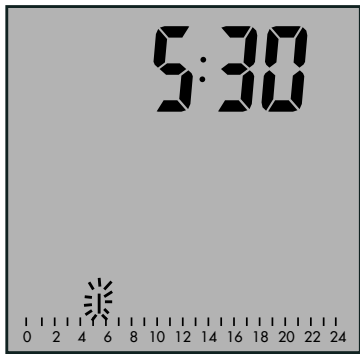
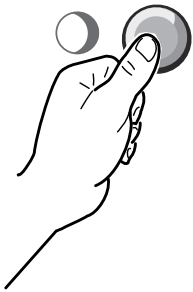

5:30 = 11x



9:00 = 7x

3

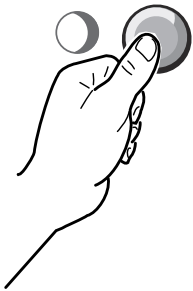

19:00 = 20x

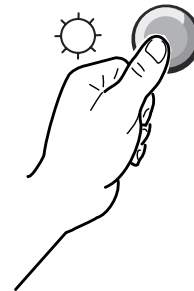

22:00 = 6x

4

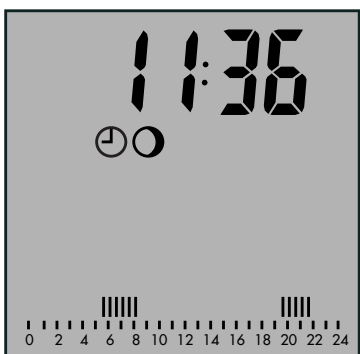

VRT 320

DE	Programm einstellen
GB	Set program
FR	Réglage programme
ES	Ajustar programa
IT	Impostare il programma
NL	Programma instellen
DK	Indstilling af program
PL	Ustawienie programu
HU	Program beállítása
CZ	Nastavení programu
RO	Modificarea programelor
HR	Podesiti program
SK	Nastavenie programu
TR	Ana program seçimi
RUS	Задание программ
PT	Efectuar programa

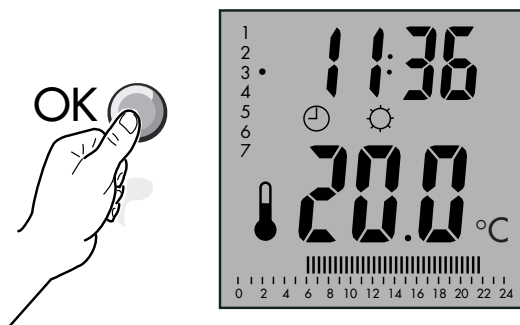
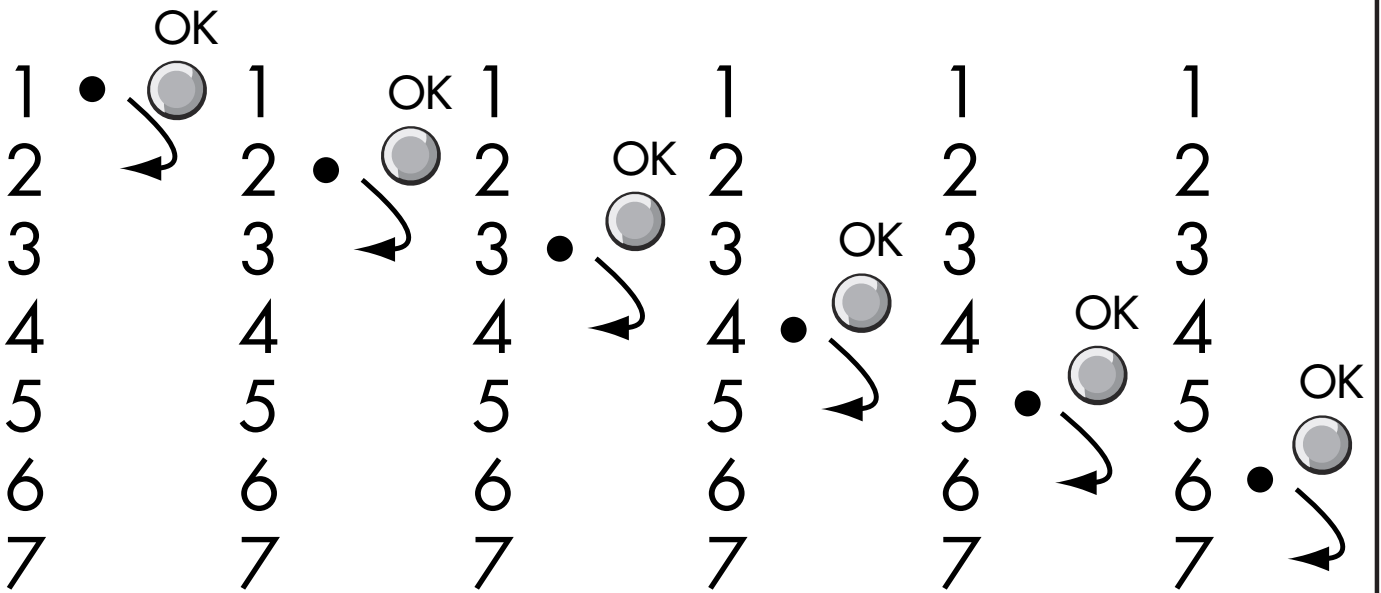
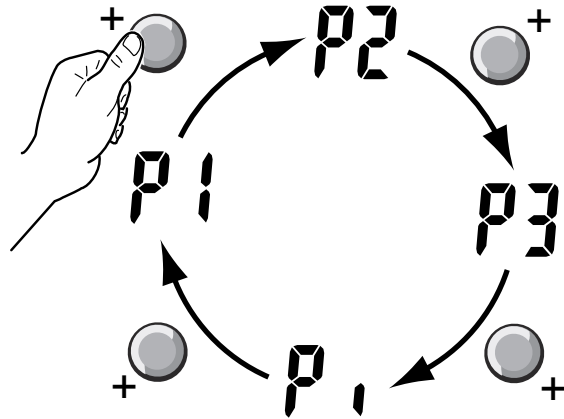
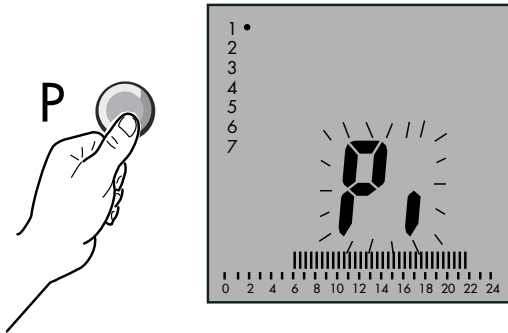
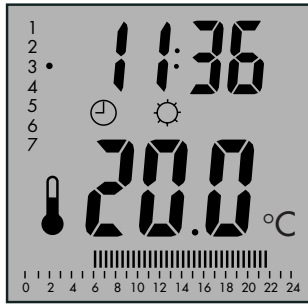

VRT 330

DE	Programm auswählen
GB	Choose a program
FR	Choix du programme
ES	Seleccionar programa
IT	Scelta del programma
NL	Programma's kiezen
DK	Valg af program
PL	Wybór programu podstawowego
HU	Program kiválasztása
CZ	Výběr základního programu
RO	Selectarea programului de bază
HR	Odabrati program
SK	Výber základného programu
TR	Programın seçilmesi
RUS	Выбор программы
PT	Seleccionar programa base

1

3x

2

5:30 = 11x

9:00 = 7x

3

19:00 = 20x

22:00 = 6x

4

VRT 330

DE	Programm P3 und Pi einstellen
GB	Set program P3 or Pi
FR	Réglage Programmes P3 et Pi
ES	Ajustar programa P3 y Pi
IT	Impostazione dei programmi P3 e Pi
NL	Programma's P3 en Pi instellen
DK	Indstilling af program P3 og Pi
PL	Ustawienie programów P3 i Pi
HU	P3 és Pi program beállítás
CZ	Nastavení programu P3 a Pi
RO	Modificarea programelor P3 și Pi
HR	Podesiti program P3 i Pi
SK	Nastavenie programu P3 a Pi
TR	P3 ve Pi programlarının ayarlanması
RUS	Задание программ P3 и Pi
PT	Efectuar programa P3 e Pi

1

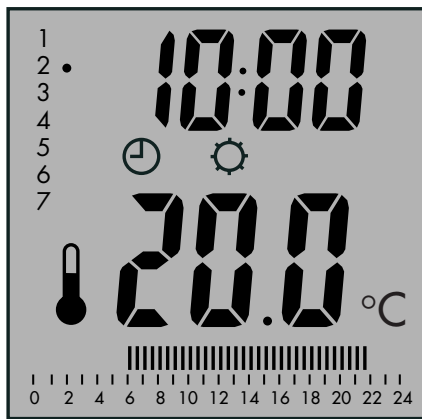

2

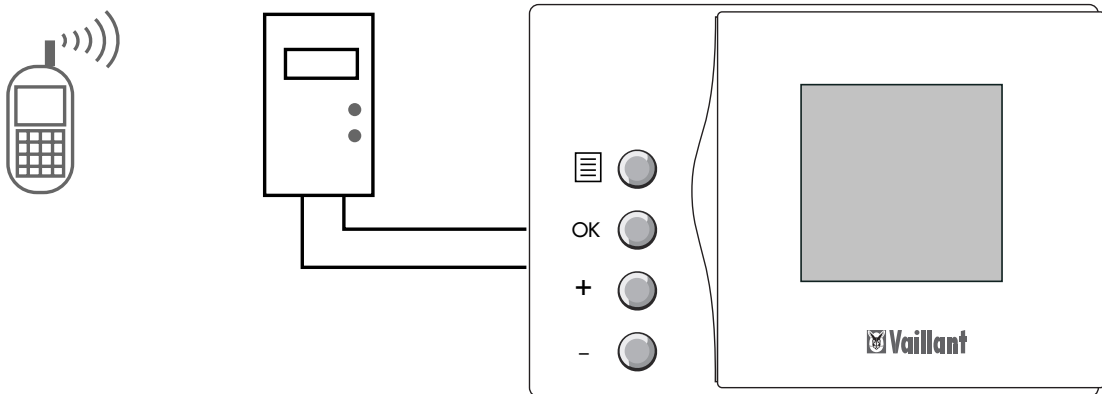

3

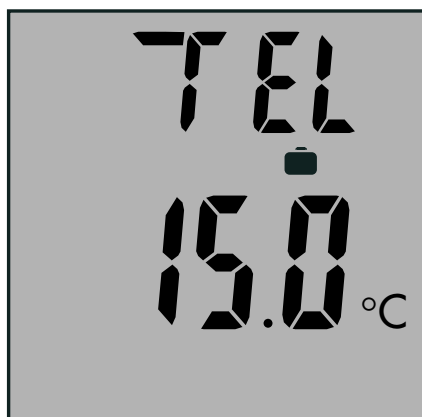

DE	Schalten über Telefonkontakt
GB	Connect with remote-control switch (not currently available in the UK)
FR	Enclenchement par téléphone
ES	Conectar por contacto telefónico
IT	Inserire il comando telefonico a distanza
NL	Inschakelen op afstand via de telefoon
DK	Styring via telefon
PL	Przełączenie przez telefon
HU	Telefoni átkapcsolás
CZ	Spínání pomocí telefonního kontaktu
RO	Cuplarea prin intermediul telefonului
HR	Upravljanje preko daljinske telefonske sklopke
SK	Zapnutie prostredníctvom telefonického kontaktu
TR	Telefon bağlantısı ile kumanda
RUS	Управление через телефонный контактор
PT	Activar através de contacto telefónico remoto

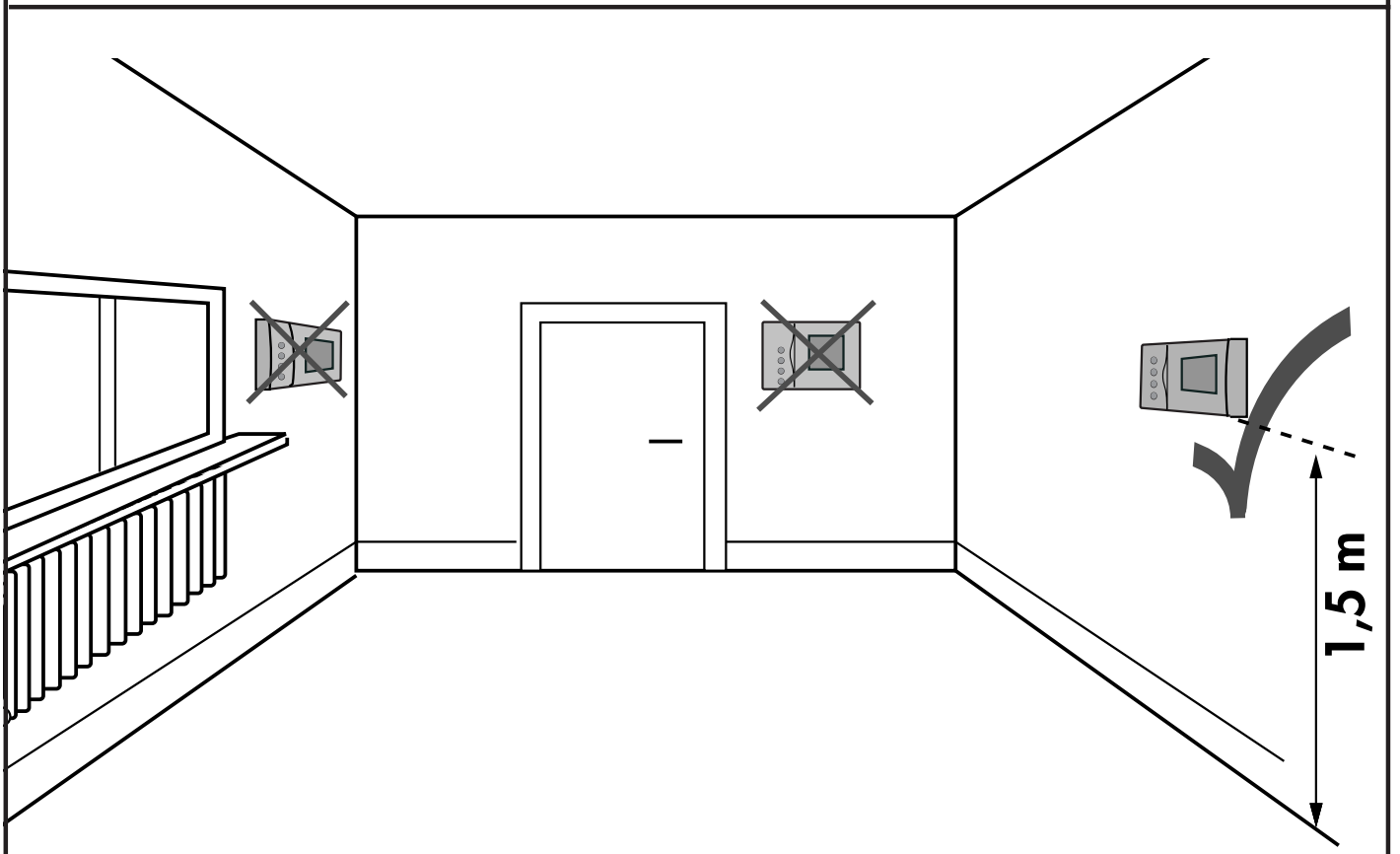
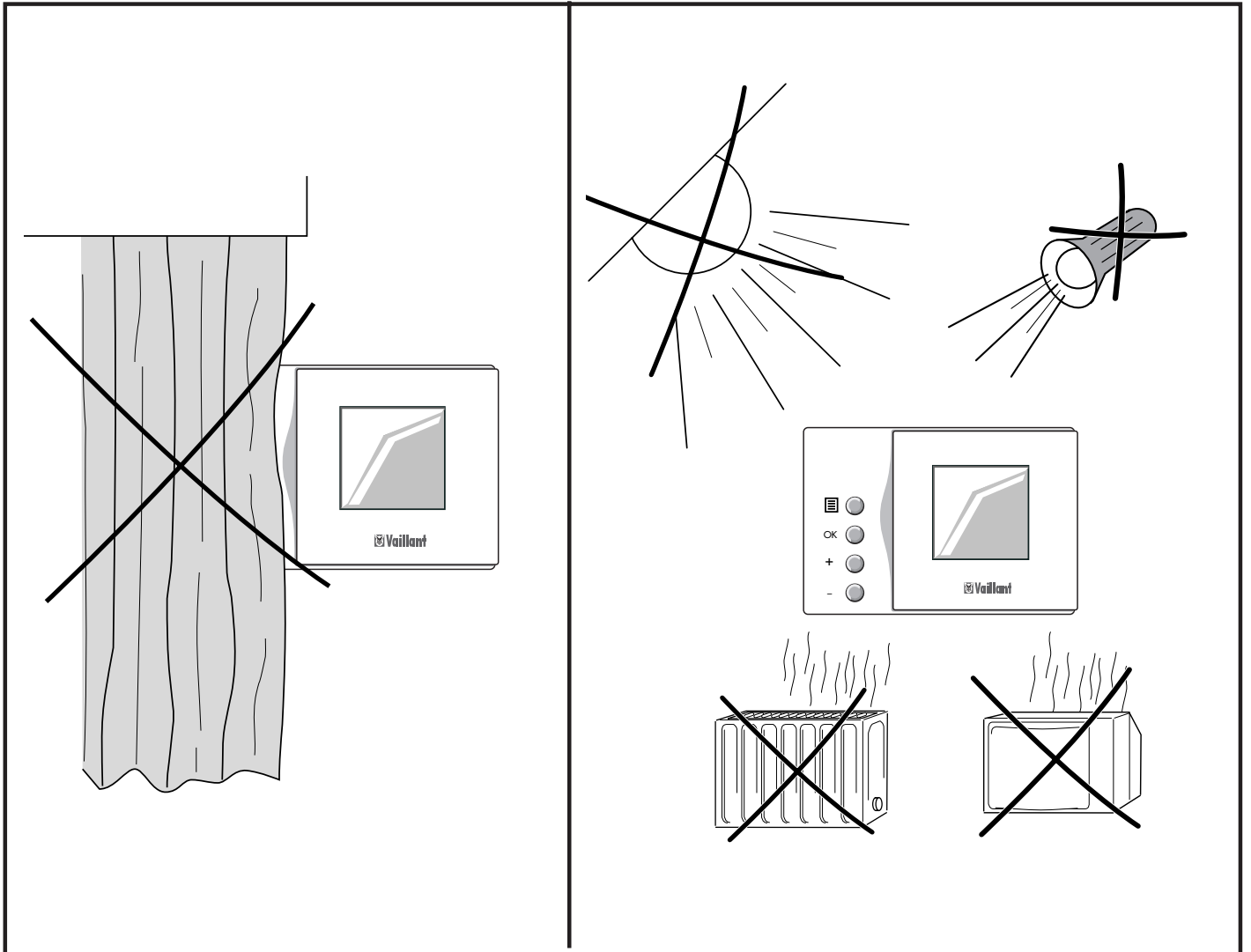

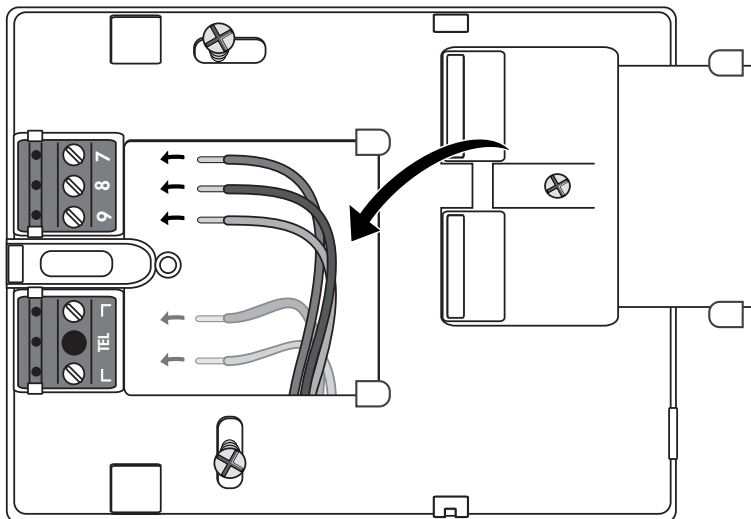
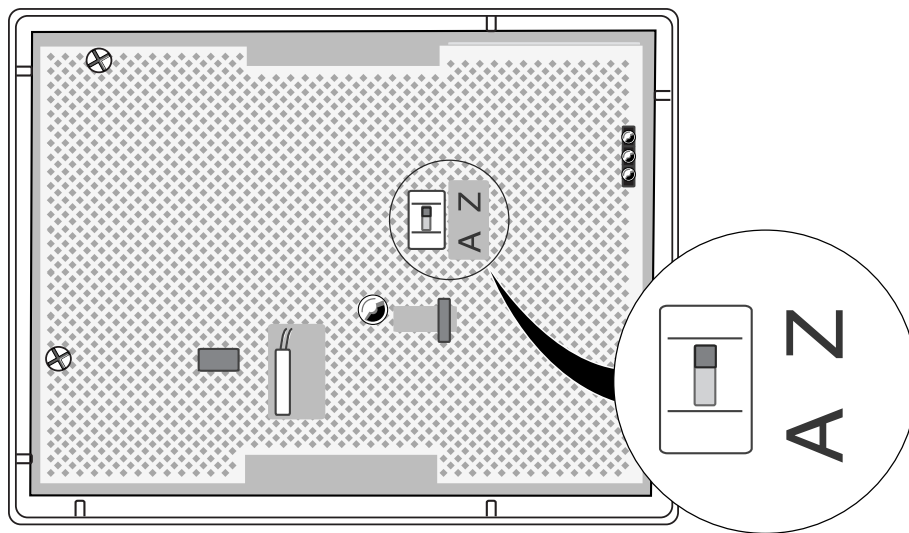
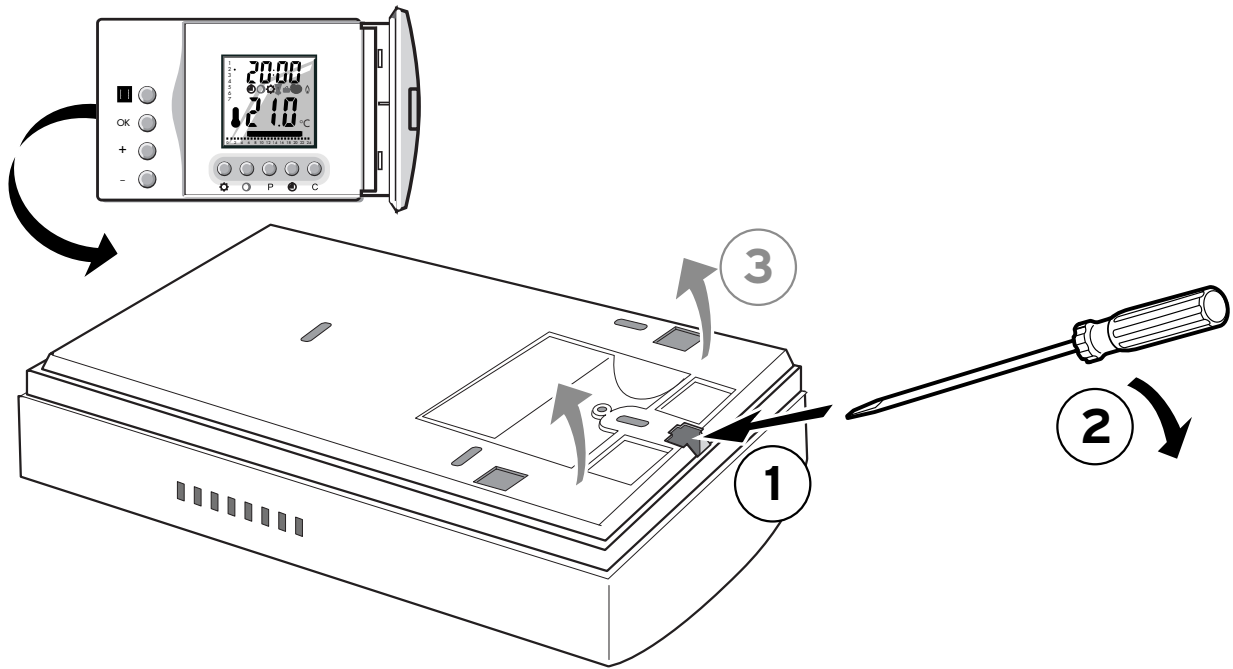

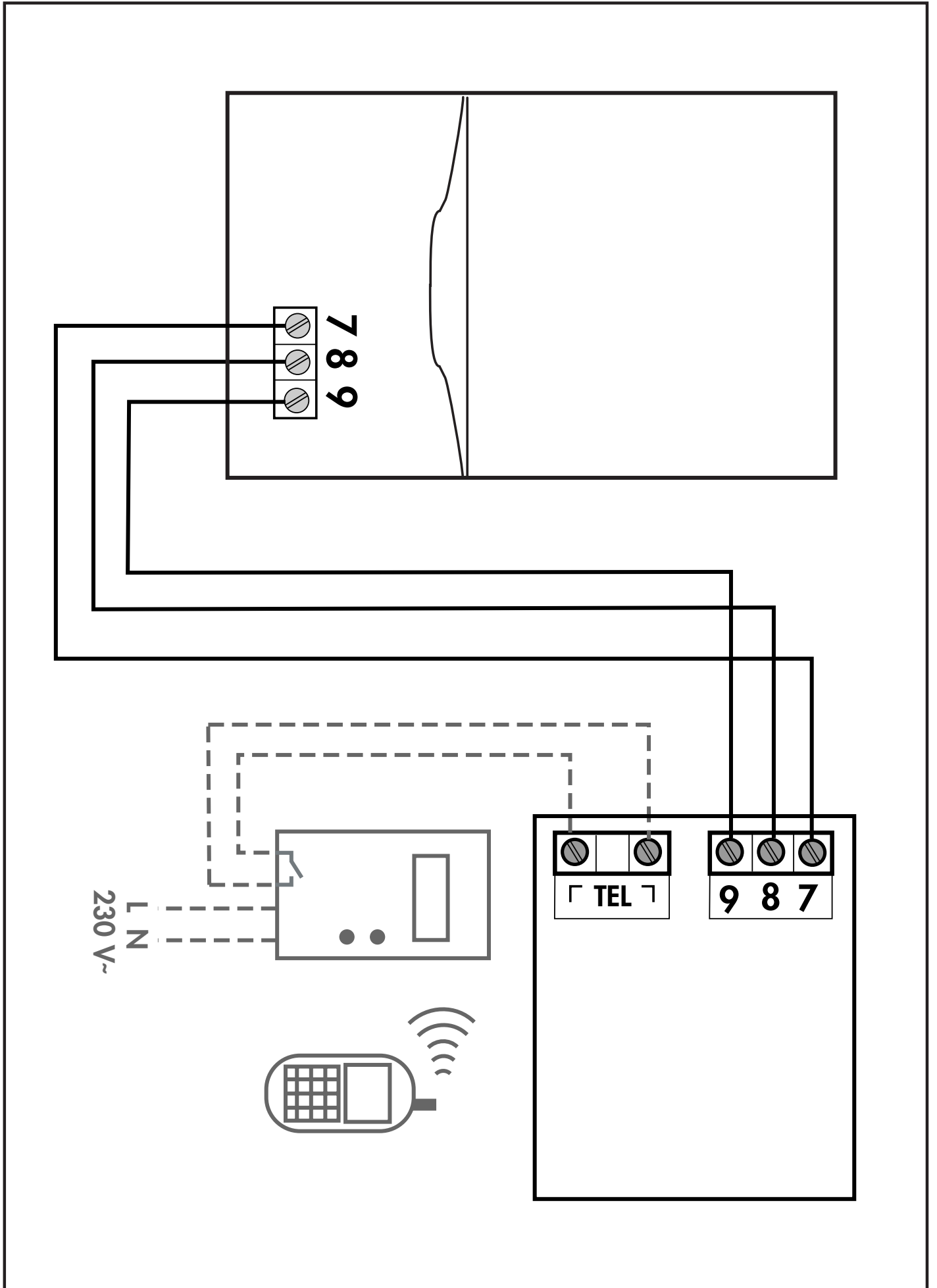

Garantía

Vaillant, S.L. garantiza el cronotermostato de ambiente VRT 320 y VRT 330 por un plazo de 2 años a partir de la fecha de compra, siempre y cuando los defectos ocasionados no sean debidos a un error de instalación, de manejo o de ajuste, explicados en este manual de uso e instalación.

Fecha de compra y sello del establecimiento:

Vaillant GmbH

Berghauser Str. 40 ■ 42859 Remscheid ■ Telefon 0 21 91/ 18-0
Telefax 0 21 91/ 18-28 10 ■ www.vaillant.de ■ info@vaillant.de