

SDV43P

FULL DC INVERTER SYSTEMS

USER MANUAL

OUTDOOR UNITS SDV4-xxxEA3P

COMMERCIAL AIR CONDITIONERS SDV4

Original instructions

IMPORTANT NOTE:

Read this manual carefully before installing or operating your new air conditioning unit. Make sure to save this manual for future reference.

CONTENTS

PAGE

IMPORTANT SAFETY INFORMATION.....	1
PARTS NAMES.....	2
OPERATION AND PERFORMANCE.....	2
TROUBLES AND CAUSES.....	3
MALFUNCTION.....	5
CONSTRAINT COOLING AND QUERY.....	6
AFTER-SALES SERVICE.....	7

1. IMPORTANT SAFETY INFORMATION

To prevent injury to the user or other people and property damage, the following instructions must be followed. Incorrect operation due to ignoring of instructions may cause harm or damage.

The safety precautions listed here are divided into two categories. In either case, important safety information is listed which must be read carefully.



WARNING

Failure to observe a warning may result in death.



CAUTION

Failure to observe a caution may result in injury or damage to the equipment.



WARNING

- **Ask your dealer for installation of the air conditioner.**
Incomplete installation performed by yourself may result in a water leakage, electric shock, and fire.
- **Ask your dealer for improvement, repair, and maintenance.**
Incomplete improvement, repair, and maintenance may result in a water leakage, electric shock, and fire.
- **In order to avoid electric shock, fire or injury, or if you detect any abnormality such as smell of fire, turn off the power supply and call your dealer for instructions.**
- **Never replace a fuse with that of wrong rated current or other wires when a fuse blows out.**
Use of wire or copper wire may cause the unit to break down or cause a fire.
- **Do not insert fingers, rods or other objects into the air inlet or outlet.**
When the fan is rotating at high speed, it will cause injury.
- **Never use a flammable spray such as hair spray, lacquers paint near the unit.**
It may cause a fire.
- **Never touch the air outlet or the horizontal blades while the swing flap is in operation.**
Fingers may become caught or the unit may break down.
- **Never inspect or service the unit by yourself.**
Ask a qualified service person to perform this work.

- **Do not dispose this product as unsorted municipal waste.** Collection of such waste separately for special treatment is necessary.

- **Keep far away from high-frequency equipment.**

- **Keep away from the following places:**
a place where it is full of oil gas; places where salty air surrounding (near the coast); a place where is caustic gas (the sulfide in hot spring). Location in the following places may cause malfunction or shorten the life span of the machine.

- **In the case of extremely strong wind, please prevent the air from flowing backwards into the outdoor unit.**

- **Snow canopy is necessary in snowfall places on the outdoor unit. Please consult the local dealer for details.**

- **In the frequent thunderstruck place, lightningproof actions should be taken.**

- **To prevent refrigerant leak, contact your dealer.**
When the system is installed and runs in a small room, it is required to keep the concentration of the refrigerant, if by any chance coming out, below the limit. Otherwise, oxygen in the room may be affected, resulting in a serious accident.

- **The refrigerant in the air conditioner is safe and normally does not leak.**
If the refrigerant leaks in the room, contact with a fire of a burner, a heater or a cooker may result in a harmful gas.

- **Turn off any combustible heating devices, ventilate the room, and contact the dealer where you purchased the unit.**
Do not use the air conditioner until a service person confirms that the portion where the refrigerant leaks is repaired.



Disposal: Do not dispose this product as unsorted municipal waste. Collection of such waste separately for special treatment is necessary.



CAUTION

- **Do not use the air conditioner for other purposes.**
In order to avoid any quality deterioration, do not use the unit for cooling precision instruments, food, plants, animals or works of art.
- **Before cleaning, be sure to stop the operation, turn the breaker off or pull out the supply cord.**
Otherwise, an electric shock and injury may result.
- **In order to avoid electric shock or fire, make sure that an earth leak detector is installed.**
- **Be sure the air conditioner is grounded.**
In order to avoid electric shock, make sure that the unit is grounded and that the earth wire is not connected to gas or water pipe, lightning conductor or telephone earth wire.
- **In order to avoid injury, do not remove the fan guard of the outdoor unit.**
- **Do not operate the air conditioner with a wet hand.**
An electric shock may happen.
- **Do not touch the heat exchanger fins.**
These fins are sharp and could result in cutting injuries.

- **After a long use, check the unit stand and fitting for damage.**
If damaged, the unit may fall and result in injury.
- **To avoid oxygen deficiency, ventilate the room sufficiently if equipment with burner is used together with the air conditioner.**
- **Arrange the drain hose to ensure smooth drainage.**
Incomplete drainage may cause wetting of the building, furniture etc.
- **Never expose little children, plants or animals directly to the air flow.**
Adverse influence to little children, animals and plants may result.
- **Notice to avoid places where operation noise may easily be spread away or be enhanced.**
- **Noise can be amplified by anything blocking the air outlet of outdoor unit.**
- Choose a proper place that the noise and hot or cold wind blown out of the outdoor unit will not bring inconvenience to your neighbors and not affect the growth or animal or plant.
- **Do not allow a child to mount on the outdoor unit or avoid placing any object on it.**
Falling or tumbling may result in injury.
- **Do not operate the air conditioner when using a room fumigation - type insecticide.**
Failure to observe could cause the chemicals to become deposited in the unit, which could endanger the health of those who are hypersensitive to chemicals.
- **Do not place appliances which produce open fire in places exposed to the air flow from the unit or under the indoor unit.**
It may cause incomplete combustion or deformation of the unit due to the heat.
- **Do not install the air conditioner at any place where flammable gas may leak out.**
If the gas leaks out and stays around the air conditioner, a fire may break out.
- **The appliance is not intended for use by person (including children) with reduced physical, sensory or mental capabilities, or lack of experience and knowledge, unless they have been given supervision or instruction concerning use of the appliance by a person responsible for their safety.**

2. PARTS NAMES

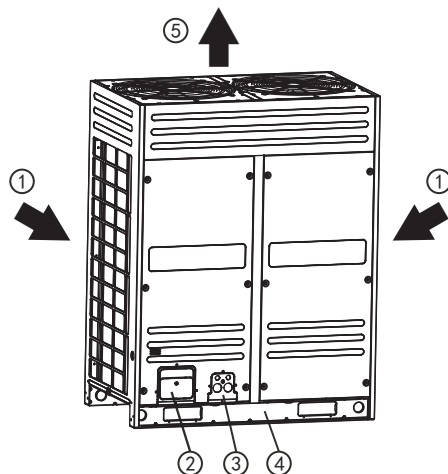

Fig.2-1

Table.2-1

①	Air inlet (Both in Left and right sides, as well as in rear side.)
②	Refrigerant pipe connective opening or wires outlet
③	Refrigerant pipe connective opening or wires outlet
④	Fixed foot
⑤	Air outlet (heat air to be blows out in the cooling operation, vice versa while the heating.)



NOTE

- All the pictures in this manual are for explanation purpose only, There may be slightly different from the air conditioner you purchased (depend on model). The actual shape shall prevail.
- To avoid danger, never put sticks or other objects into it.
- Please preheat the air conditioner for at least 12 hours before operation. Do not switchoff the power if you need to stop the unit for 24h or shorter time. (This is to heat the crank case heater to avoid the compulsive start of compressor.)
- Make sure the air inlet and outlet are not blocked, or it may degrade the performance of air conditioner or start up protector which will stop the unit from running.

3. OPERATION AND PERFORMANCE

■ Cooling and heating operation of inverter central A/C

- The indoor unit of this air conditioner can be controlled solely, and the indoor unit in the same system can run cooling and heating at the same time, but Indoor units at downstream of the same MS cannot conduct both heating and cooling, or both heating and air supplying simultaneity. (Modes conflict is displayed.)

■ Features of heating operation

- Warm air will not be blown out immediately at the beginning of the heating operation, after 3~5minutes (depends on the indoor and outdoor temperature), until the indoor heat exchanger become hot, then blows out warm air.
- During operation, the fan motor in the outdoor unit may stop running under high temperature.
- During Fan operation, if other indoor Units are running on heating mode, the fan may stop in order to prevent sending heat wind.

■ Defrost in the heating operation

- During heating operation, outdoor unit sometimes will frost. To increase efficiency, the unit will start defrosting automatically (about 2~10 minutes), and then water will be drained out from outdoor unit.
- During defrosting, both the fan motors in the outdoor unit and indoor unit will stop running.

■ Operation conditions

For proper performance, run the air conditioner under the following temperature conditions:

Table.3-1

Temperature Mode	Outdoor temperature	Indoor temperature	Room relative humidity
Cooling mode	-5°C ~ 48°C	17°C ~ 32°C	below 80%
Heating mode	-20°C ~ 24°C	≤27°C	
Mixed mode	-5°C ~ 24°C	Cooling mode 17°C ~ 32°C	
		Heating mode ≤27°C	



NOTE

Protective device may start if running the unit outside the above condition, which will prevent the unit from operation.

■ Protection Device

This protection device will stop the unit automatically in case the air conditioner is on forced running mode. When protection device is activated, running indicator light is lightened and query light flashes. Protection device may start under the following circumstances:

■ cooling operation:

- The air inlet or air outlet of outdoor unit is blocked.
- Strong wind is continuously blowing to the air outlet of the outdoor unit.

■ heating operation:

- Too much dust and rubbish adhere to the dust filter in the indoor unit

■ Power cut

- If power is cut during operation, stop all the operation immediately.
- Power comes again. The operation indicator on the wire controller flashes.
- Push the ON/OFF button again if you want to restart the unit.

■ Mishandling in operation

In case of mishandling caused by lighting or mobile wireless, please switch off the manual power off the manual power. Push ON/OFF again when restarting.

■ Heating capacity

- The heating process is :absorb heat from outdoor, while expel heat to indoor by hot pump. Once the outdoor temperature drop down, heating capacity is degraded correspondingly.
- It is command to equip with other warming facility, when outdoor temperature is low.
- It is better to equip with additional purchase indoor auxiliary heating device in paramos area where is in particularly low outdoor temperature.(See Indoor Unit Operation Manual for detail information)



NOTE

Please switch off the power when protection device starts. Do not restart until the problems are solved.

4. TROUBLES AND CAUSES



CAUTION

- In case the following malfunctions, please switch off the power and contact the local dealer.Incorrect ON/OFF operation
- Fuse or leakage protector is frequently broken.
- Foreign matter or water falls in the unit.

Please read the following illustration(before apply for servicing)

Table.4-1

	Troubles	Causes
Not malfunction	Outdoor unit <ul style="list-style-type: none"> • White mist or water • The sound of "hiss" 	<ul style="list-style-type: none"> • FAN function stop automatically to defrost. It is the start and stop sound of the solenoid valve • At the beginning and the end of the running process, sounds like water flow in valve occurs, which will be amplified in 3~15 minutes, this is caused by dehumidifying process of refrigerant current. • Slight hiss is caused by heat exchanger as temperature changes. • Pieces of the wall, carpet, furniture, cloth, cigarette, cosmetics are adhere to the unit. • Switch on the power after the power cut. • Other equipment preheating process stops cooling operation. • The operator sets an opposite mode against the fixed cooling and heating mode. • FAN mode stops to avoid cold air blown out. • The master unit with slave units for different purposes, when abnormal accident happen,the director will illustrate. • When mode switches
	Indoor unit <ul style="list-style-type: none"> • Bad odor • Operation lamp flashes • No priority of Standby on panel is lightened • Thawing frost light flashes in 30s 	
Check it again	<ul style="list-style-type: none"> • Start or stop operation automatically 	<ul style="list-style-type: none"> • Wrong operation on timer.
	<ul style="list-style-type: none"> • No operation 	<ul style="list-style-type: none"> • Whether the power is cut. • Whether manual power switch is turned on. • Whether the fuse is melted. • Whether the protection device works. (operation lamp is lightened) • Whether it is the time set.
	<ul style="list-style-type: none"> • Insufficient cooling • Insufficient heating 	<ul style="list-style-type: none"> • Whether the inlet and outlet of outdoor unit is blocked. • Whether the door and window are open. • Whether the air filter is blocked by dust. • Whether the air deflector is in the right place • Whether fan speed is slight or whether it is in FAN mode. • Whether the temperature is set properly. • Whether setting COOL and HEAT simultaneously. (Indicator light Standby or No Priority on panel is lightened)

5. MALFUNCTION

Malfunction display of outdoor unit's DSP1 and DSP2

Table.5-1

No.	Error code	Error or protection type	Note
1	E0	Outdoor unit communication error	Only display in auxiliary unit
2	E1	Phase error	
3	E2	Communication error with indoor unit	20 minutes after first power on or indoor and outdoor communication break off over 2 minutes after first power on 20 minutes
4	E4	Outdoor temp. sensor error	
5	E5	Voltage protection	
6	E7	Discharge sensor error	After running 10 minutes, it appears discharge temp. < 15°C and pressure > 3.5MPa. The appearance sustains 2 minutes. Must restart electricity, otherwise cannot recover.
7	E8	Outdoor unit address error	
8	xE9	Drive type mismatch	
9	xH0	Communication error between DSP and main chip	X represents for a system, 1 is A system, 2 is B system
10	H1	Communication error between 0537 and main chip	X represents for a system, 1 is A system, 2 is B system
11	H2	Qty. of outdoor unit decreases error	Only display in main unit
12	H3	Qty. of outdoor unit increases error	Only display in main unit
13	xH4	3 times of P6 protection in 60 minutes	Must restart electricity, otherwise cannot recover
14	H5	3 times of P2 protection in 60 minutes	Must restart electricity, otherwise cannot recover
15	H6	3 times of P4 protection in 100 minutes	Must restart electricity, otherwise cannot recover
16	H7	Qty. of indoor units mismatch	Indoor unit lost for over 3 minutes; not recoverable until the unit qty. recover
17	H8	High pressure sensor error	Air discharging pressure $P_c \leq 0.3$ MPa
18	H9	3 times of P9 protection in 60 minutes	Must restart electricity, otherwise cannot recover
19	C7	3 times of PL protection in 100 minutes	Must restart electricity, otherwise cannot recover
20	xHd	Auxiliary unit error (X=1,2,3, e.g., 1Hd stands for auxiliary unit 1 error)	X represents for a auxiliary unit
21	P0	Inverter compressor top temp. protection	
22	P1	High pressure protection	
23	P2	Low pressure protection	After 3 times P2 protection in 60 minutes will report H5
24	xP3	Compressor current protection	X represents for a system, 1 is A system, 2 is B system
25	P4	Discharge temp. protection	After 3 times P6 protection in 100 minutes will report H6
26	P5	High condenser temp. protection	
27	x(P6)	Inverter module protection	X represents for a system, 1 is A system, 2 is B system. After 3 times (P6) protection in 60 minutes will report H4. If appearing protection and cannot recover in 10 minutes, it will report xP6.
28	P7	Main inverter current protection	
29	P8	Auxiliary inverter current protection	
30	P9	DC fan protection	After 3 times P9 protection in 60 minutes will report H9
31	PL	Main inverter module temp. protection	
32	xL0	DC compressor module error	X represents for a system, 1 is A system, 2 is B system
33	xL1	DC bus low pressure protection	X represents for a system, 1 is A system, 2 is B system
34	xL2	DC bus high pressure protection	X represents for a system, 1 is A system, 2 is B system
35	xL3	Reserve	X represents for a system, 1 is A system, 2 is B system
36	xL4	MCE error/synchronization/closed loop	X represents for a system, 1 is A system, 2 is B system
37	xL5	Zero speed protection	X represents for a system, 1 is A system, 2 is B system
38	xL6	Reserve	X represents for a system, 1 is A system, 2 is B system
39	xL7	Phase error protection	X represents for a system, 1 is A system, 2 is B system
40	xL8	Protection of the speed change between a moment before and after is > 15Hz	X represents for a system, 1 is A system, 2 is B system
41	xL9	Protection of the speed change between the setting speed and the actual speed > 15Hz	X represents for a system, 1 is A system, 2 is B system

6. CONSTRAINT COOLING AND QUERY

■ Constraint Cooling

Once pressing the constraint cooling button(see the chart on the right), all the indoor unit will be on forced cooling mode and the wind speed is HIGH.

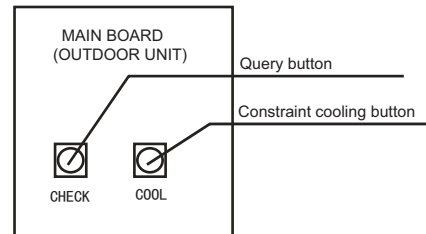

■ SW2 Query Instructions

Fig.6-1

Table.6-1

No.	Normal display	Display content	Note
1	0. --	Outdoor unit address	0,1,2,3
2	1. --	Outdoor unit itself capacity	8,10,12,14,16
3	2. --	Modular outdoor unit qty.	Available for main unit
4	3. --	Operation mode	0,2,3,4,5,6
5	4. --	Total capacity of outdoor unit	Capacity requirement
6	5. --	Cooling capacity	Auxiliary unit only display capacity of main mode
7	6. --	Heating capacity	Auxiliary unit only display capacity of main mode
8	7. --	T4 ambient temp. revision of cooling capacity	
9	8. --	T4 ambient temp. revision of heating capacity	
10	9. --	The outdoor unit actual operation capacity	Capacity requirement
11	10. --	Speed of fan A	0, 1, ..., 14, 15
12	11. --	Speed of fan B	0, 1, ..., 14, 15
13	12. --	T2 average temp.	Actual value
14	13. --	T2B average temp.	Actual value
15	14. --	T3 pipe temp. (Left pipe temp.)	Actual value
16	15. --	T5 pipe temp. (Right pipe temp.)	Actual value
17	16. --	T4 ambient temp.	Actual value
18	17. --	Discharge temp.of inverter compressor A	Actual value
19	18. --	Discharge temp.of inverter compressor B	Actual value
20	19. --	Modual temp.	Actual value
21	20. --	Discharge pressure corresponding to the saturation temperature	Actual value+30
22	21. --	The minimum overheating temp. of discharge	Actual value
23	22. --	Current of inverter compressor A	Actual value
24	23. --	Current of inverter compressor B	Actual value
25	24. --	State of the evaporator or condenser	0,1,2,3
26	25. --	Opening angle of EXV A	Actual value+8
27	26. --	Opening angle of EXV B	Actual value+8
28	27. --	High pressure	Actual value×10
29	28. --	Qty. of indoor units	That can communicate with indoor units
30	29. --	Qty. of cooling indoor units	Actual value
31	30. --	Qty. of heating indoor units	Actual value
32	31. --	Reserve	
33	32. --	Night noise control mode	0,1,2,3
34	33. --	Static pressure mode	0,1,2,3
35	34. --	DC voltage A	Actual value+10
36	35. --	DC voltage B	Actual value+10
37	36. --	Reserve	
38	37. --	Reserve	Display code 8.8.8
39	38. --	Remove fault number of times	
40	39. --		Check end

The display contents as followings:

Normal display:

When standby, the high position displays the address of the outdoor unit, and the low position displays the Qty. of indoor units that can communicate with outdoor unit. When it is operating, it will display the rotation frequency of the compressor.

Operation mode:

0-Off; 2-Cooling; 3-Heating; 4-Forcing cooling; 5-Mixed cooling; 6-Mixed Heating.

Fan speed:

0-stop; 1~15 speed increase sequentially, 15 is the max. fan speed. EXV opening angle: Pulse count=Display value×8;

State of the evaporator or condenser:

0-close/condenser; 1-All evaporator; 2-Left evaporator/right condenser; 3-Left evaporator/close

Night noise control mode:

0-Night noise control mode; 1-silent mode; 2-Most silent mode; 3-No priority

Static pressure mode:

0-static pressure is 0 Mpa; 1-Low static pressure; 2-Medium static pressure; 3-High static pressure

7. AFTER-SALES SERVICE

If the air conditioner was operate abnormally, please plug off the power supply firstly, and contact with After-sales Center or Special Distributor. For detail please refer to the attached accessory Consumer Service Instruction.

NOTE CONCERNING PROTECTION OF ENVIRONMENT



This product must not be disposed of via normal household waste after its service life, but must be taken to a collection station for the recycling of electrical and electronic devices. The symbol on the product, the operating instructions or the packaging indicate such disposal procedures. The materials are recyclable in accordance with their respective symbols. By means of re-use, material recycling or any other form of recycling old appliances you are making an important contribution to the protection of our environment. Please ask your local council where your nearest disposal station is located.

INFORMATION CONCERNING USED REFRIGERANT MEDIUM

This unit is containing fluorinated gases included in the Kyoto protocol. The maintenance and the liquidation must be carried out by qualified personnel.

Type of refrigerant: R410A

The composition of the cooling medium R410A: (50% HFC-32, 50% HFC-125)

The quantity of the refrigerant: please see the unit label.

The value GWP: 2088 (1 kg R410A = 2,088 t CO₂ eq)

GWP = Global Warming Potential

In case of quality problem or other please contact your local supplier or authorized service center.

Emergency number: 112

PRODUCER

SINCLAIR CORPORATION Ltd.

1-4 Argyll St.

London W1F 7LD

Great Britain

www.sinclair-world.com

This product was manufactured in China (Made in China).

REPRESENTATIVE

SINCLAIR EUROPE spol. s r.o.

Purkynova 45

612 00 Brno

Czech Republic

TECHNICAL SUPPORT

NEPA spol. s r.o.

Purkynova 45

612 00 Brno

Czech Republic

Tel.: +420 541 590 140

Fax: +420 541 590 124

www.sinclair-solutions.com

info@sinclair-solutions.com

