



AIRCONDITIONER FLOOR STANDING TYPE

SERVICE MANUAL

RS-FS24AB/RU-24AC1
RS-FS48AB/RU-48AC3

CONTENTS

1.	Safety Precautions.....	1
1.1	Precaution.....	1
1.2	Installation.....	1
1.3	Caution	1
1.4	Operational	2
2.	Dimension	3
2.1	Indoor Unit.....	3
2.2	Outdoor Unit	4
3.	Refrigerant cycle diagram.....	5
3.1	Heat pump mode	5
4.	Wiring diagram.....	6
4.1	RS-FS24AB	6
4.2	RS-FS48AB	7
5.	Installation details.....	8
5.1	Installation place	8
5.2	Installing.....	10
5.3	Refrigerant pipe connection.....	12
5.4	Drain Pipe of The Indoor Unit	24
5.5	Wiring.....	25
5.6	Test operation	25
6.	External view and display	26
6.1	External view	26
6.2	Display panel	27
7.	Operation characteristics.....	27
8.	Electronic function	28
8.1	Main data Introduction	28

8.2	Operation Modes and Functions	28
8.3	Other Functions	31
9.	Characteristic of temperature sensor	32
10.	Trouble shooting.....	32
10.1	Protective Function	32
10.2	Self-diagnosis	34
10.3	LEDs for the indication of outdoor trouble(only for 42K).....	34
10.4	Troubles and Solutions	35

1. Safety Precautions

1.1 Precaution

To prevent injury to the user or other people and property damage, the following instructions must be followed.

Incorrect operation due to ignoring instruction will cause harm or damage.

Before service unit, be sure to read this service manual at first.

1.2 Installation

For electrical work, contact the dealer, seller, a qualified electrician, or an Authorized service center.

Do not disassemble or repair the product by yourself.

Sharp edges could cause injury, be especially careful of the case edges and the fins on the condenser and evaporator.

Be sure the installation area does not deteriorate with age.

Take care to ensure that power cable could not be pulled out or damaged during operation.

Do not place anything on the power cable.

Do not plug or unplug the power supply plug during operation.

Do not store or use flammable gas or combustible near the product.

When flammable gas leaks, turn off the gas and open a window for ventilation before turn the product on.

If strange sounds, or small or smoke comes from product. Turn the breaker off or disconnect the power supply cable as soon as possible.

When the product is soaked (flooded or submerged), contact an Authorized service center.

Be caution that water could not enter the product.

Turn the main power off when cleaning or maintaining the product.

When the product is not be used for a long time, disconnect the power supply plug or turn off the breaker.

1.3 Caution

Always check for gas (refrigerant) leakage after installation or repair of product.

Install the drain hose to ensure that water is drained away properly.

Keep level even when installing the product.

Do not install the product where the noise or hot air from the outdoor unit could damage the neighborhoods.

Use two or more people to lift and transport the product.

Do not install the product where it will be exposed to sea wind (salt spray) directly.

1.4 Operational

Do not expose the skin directly to cool air for long periods of time. (Do not sit in the draft).

Do not use the product for special purposes, such as preserving foods, works of art, etc. It is a consumer air conditioner, not a precision refrigerant system.

Do not block the inlet or outlet of air flow.

Use a soft cloth to clean. Do not use harsh detergents, solvents, etc.

Do not touch the metal parts of the product when removing the air filter. They are very sharp.

Do not step on or put anything on the product. (outdoor units)

Always insert the filter securely. Clean the filter every two weeks or more often if necessary.

Do not insert hands or other object through air inlet or outlet while the product is operated.

Do not drink the water drained from the product.

Use a firm stool or ladder when cleaning or maintaining the product.

Replace the all batteries in the remote control with new ones of the same type. Do not mix old and new batteries or different types of batteries.

Do not recharge or disassemble the batteries. Do not dispose of batteries in a fire.

If the liquid from the batteries gets onto your skin or clothes, wash it well with clean water. Do not use the remote if the batteries have leaked.

2. Dimension

2.1 Indoor Unit

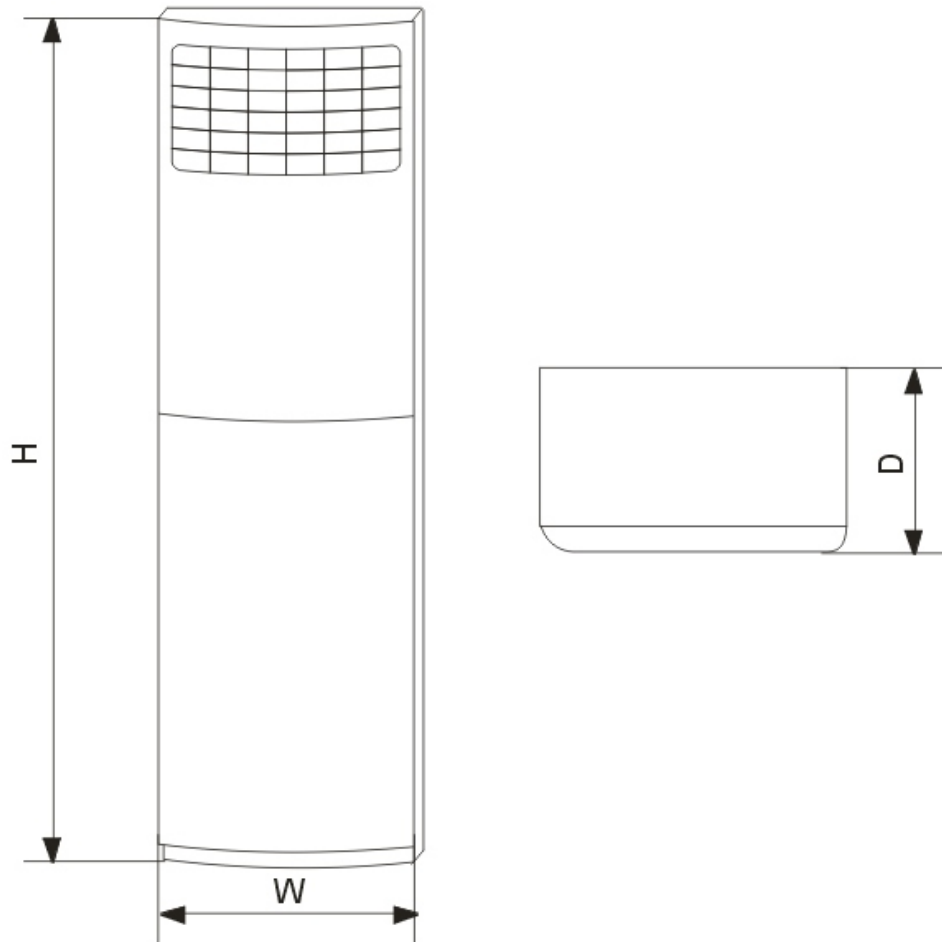

Model	W (mm)	D (mm)	H (mm)
24K	500	290	1700
48K	540	410	1825

2.2 Outdoor Unit

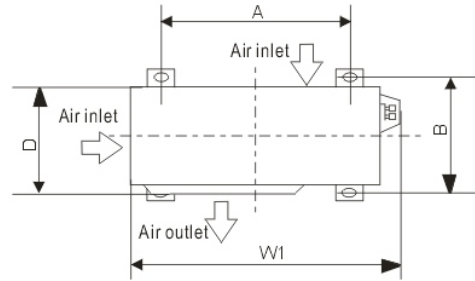
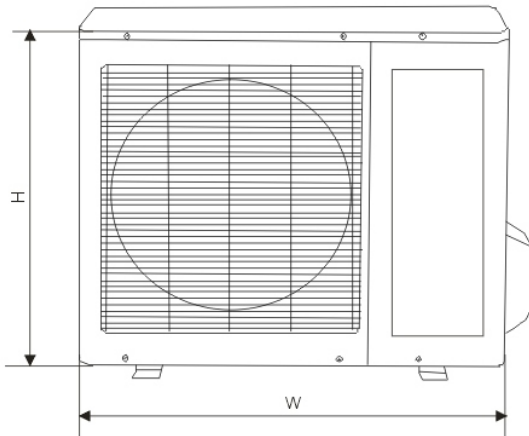

Dimension Mode	W (mm)	D (mm)	H (mm)	W1 (mm)	A (mm)	B (mm)
24K	845	335	695	918	560	335

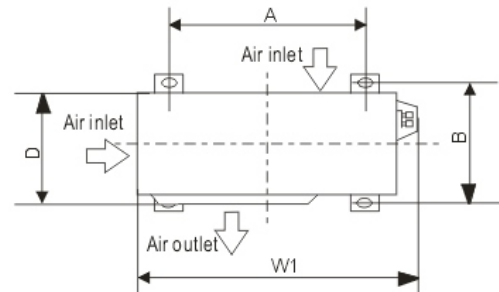
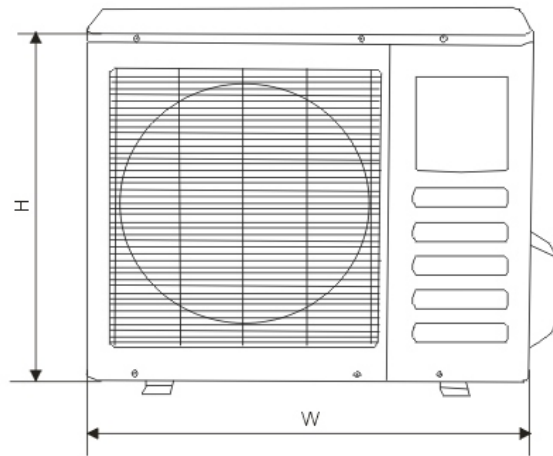

Dimension Mode	W (mm)	D (mm)	H (mm)	W1 (mm)	A (mm)	B (mm)
48K	990	355	965	1075	623	366

3. Refrigerant cycle diagram

3.1 Heat pump mode

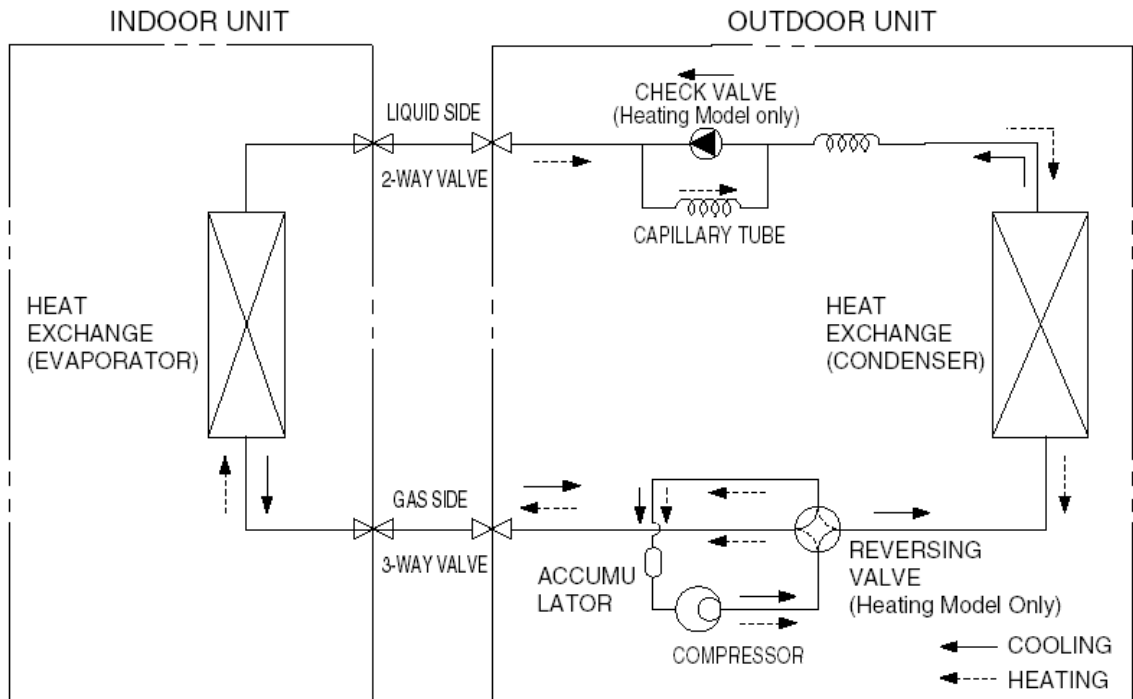

4. Wiring diagram

4.1 RS-FS24AB

Indoor Unit

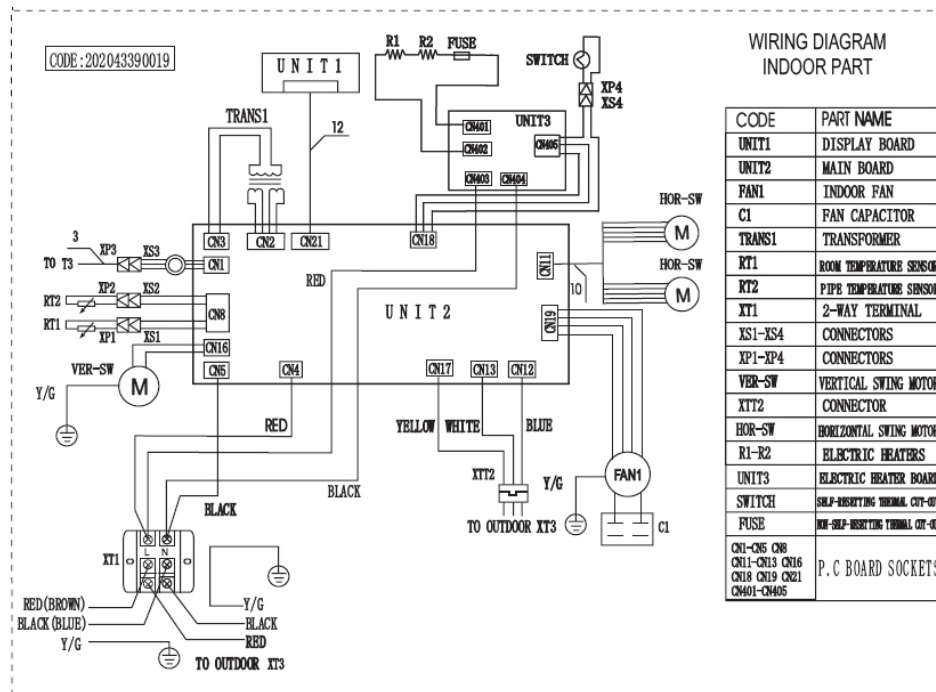

Outdoor Unit

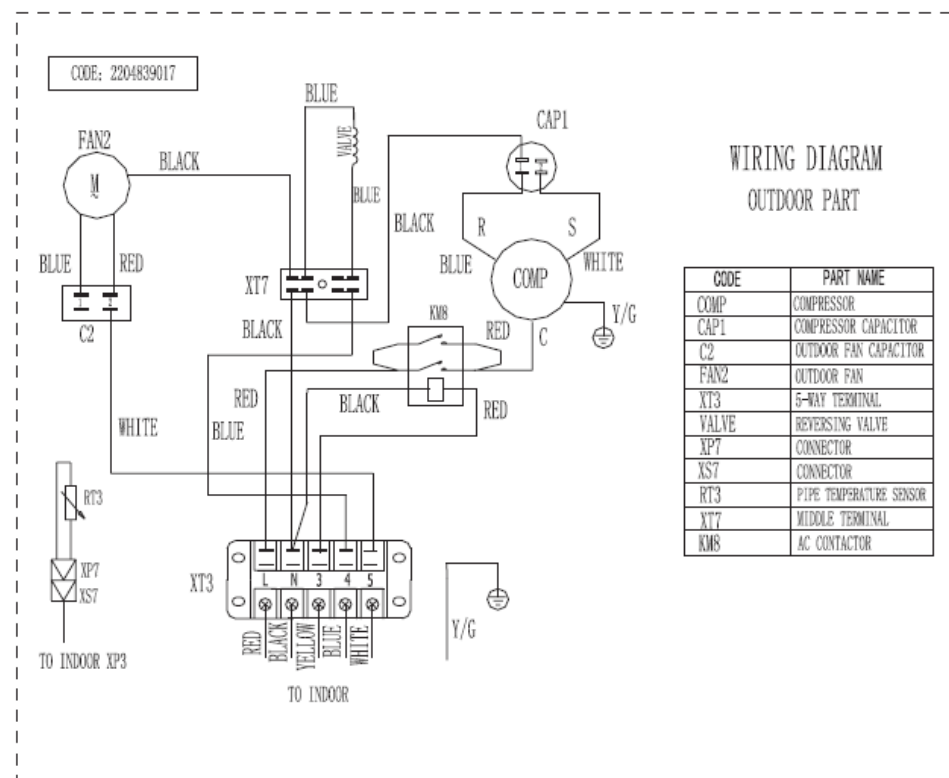

4.2 RS-FS48AB

Indoor Unit

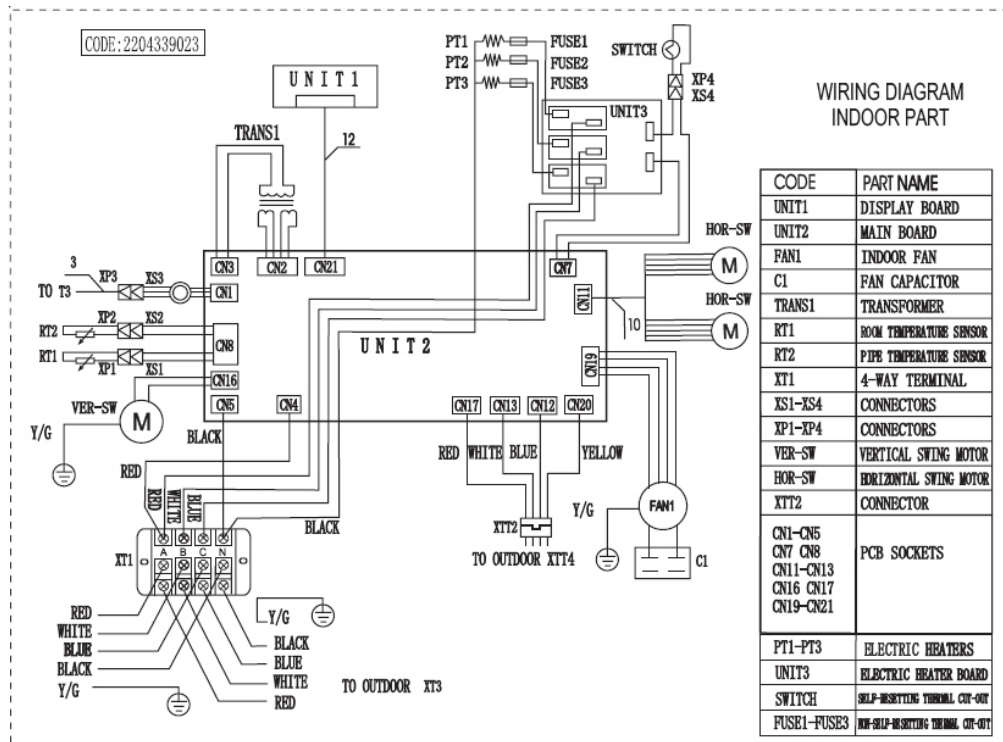

Outdoor Unit

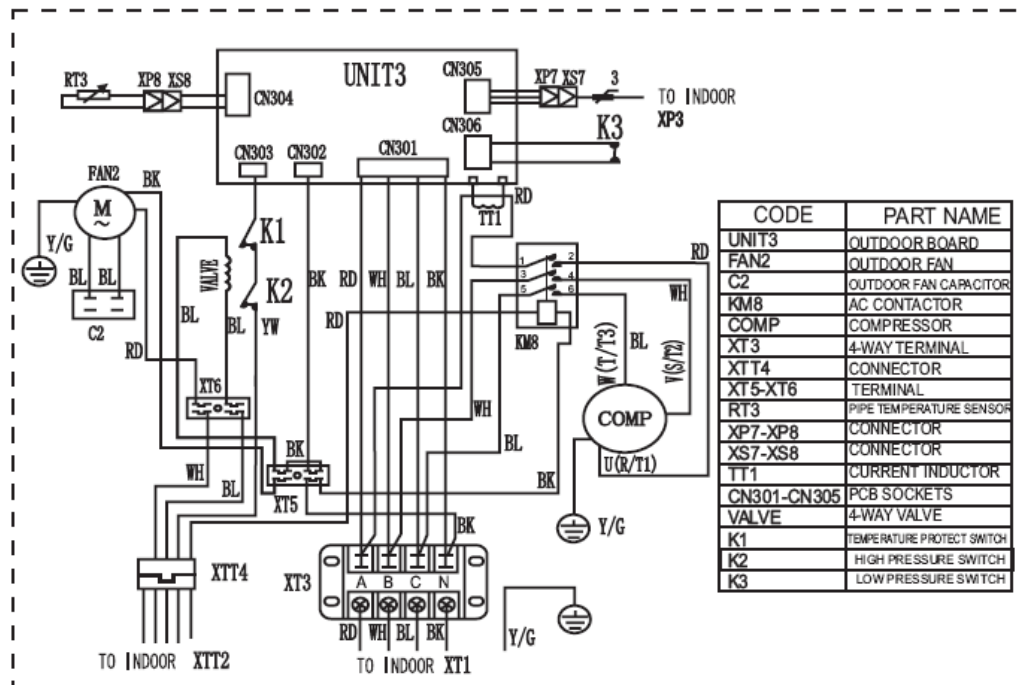

5. Installation details

5.1 Installation place

5.1.1 Indoor Unit

- a. Ensure the spaces indicated by arrows from the wall, ceiling, fence or other obstacles.
- b. There should not be any heat source or steam near the unit.
- c. There should not be any obstacles blocking the air circulation.
- d. A place where air circulation in the room is good.
- e. A place where drainage can be easily done.
- f. Do not install the unit near the door way.
- g. There should not be any direct sunlight. Otherwise, the sun will fade the plastic cabinet and affect its appearance. If unavoidable, sunlight prevention should be taken into consideration.

5.1.1.1 Please stand the unit in hard and flat ground;

Please reserve space for installation and maintenance.

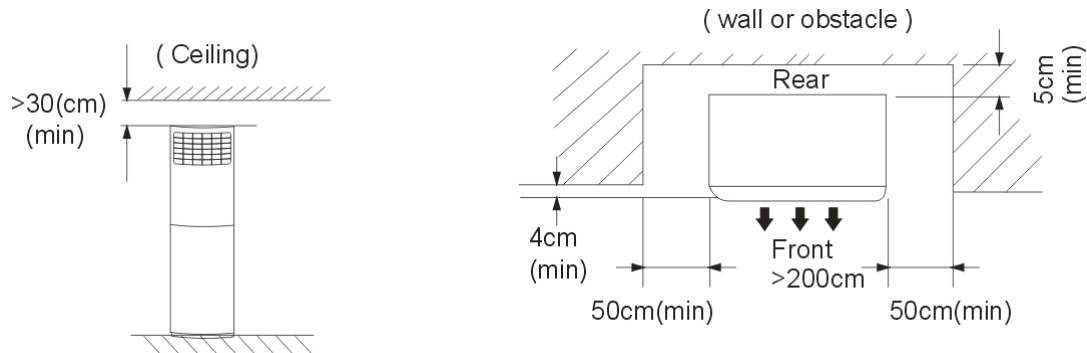

5.1.1.2 Please check the elevation difference between the indoor unit and the outdoor unit, the length of the refrigerant pipe, and the curved places (bend) of the pipe are no more than the following numbers:

Elevation difference: no more than 10M(24K) or 15M(42K and 48K) (if the elevation difference between indoor and outdoor unit is more than 10 or 15 meters, it is recommended that the indoor unit be located higher than the outdoor unit.)

Pipe length: no more than 20M(24K) or 30M(42K and 48K)

Bends: no more than 3 places.

5.1.2 Outdoor Unit

The outdoor unit should be put in a position that guarantees the minimum space for sufficient air circulation and to allow maintenance work and the connections of electrical and refrigerant circuit lines. It may be installed on a floor or flat roof or wall-mounted, provided its weight is properly supported and there is no transmission of vibration to the adjacent rooms.

5.1.2.1 Before installing the outdoor unit, you should:

- a). If an awning is built over the unit to prevent direct sunlight or rain, be careful that heat

radiation from the condenser is not obstructed.

- b). Select a place that is easy to connect indoor unit's pipe and electric wires.
- c). Avoid a place where combustible gas may leak or stay.
- d). Keep it in mind that water may drain out of the outdoor unit while in "Heat" mode.
- e). Ensure the space around the back and sides and the front of the unit.
- f). Take the air conditioner weight into account and select a place where noise and vibration are minimum.

5.1.2.2 If the outdoor unit is to be installed on a roof or where no constructions are around, you should avoid hard wind blows directly to the air outlet, because it may cause trouble for air-flow shortage.

For example:

Let the air outlet face a wall (if there is one) with a distance about 300 centimeters between them.

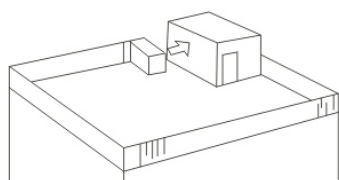

Try to make the air outlet vertical to wind direction if it is known in the season you use the system.

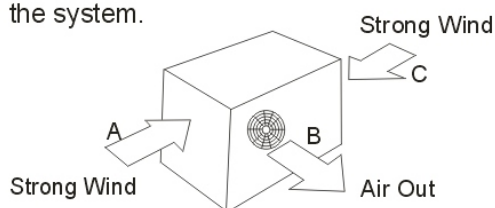

In directions (A), (B), (C), leave open two of the three directions.

5.1.2.3 Reserve enough space for installation, maintenance and unit-functioning.

Remove as many obstacles as possible nearby.

When the air-in surface is facing a wall

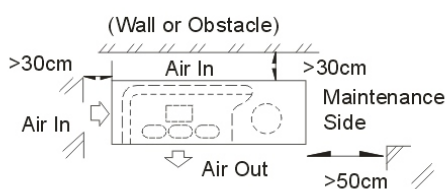

When the air-out surface is facing a wall

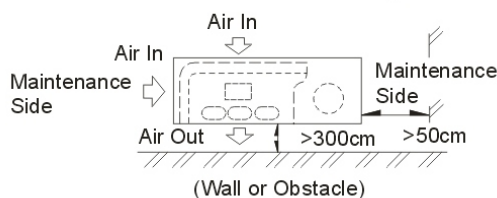

Caution:

Installation in the following places may cause trouble. If it is unavoidable to use in such places, please consult with the dealer.

- (1) A place full of machine oil.
- (2) A saline place such as coast.
- (3) Hot-spring resort.
- (4) A place full of sulfide gas.
- (5) A place where there are high frequency machines such as wireless installation, welding machine, medical facility.
- (6) A place of special environmental conditions.

5.2 Installing

5.2.1 Indoor Unit:

1. Anti-falling;

To prevent the indoor unit from falling, you must:

- a. Pay full attention to the unit because its long outer shape makes it easy to fall;
- b. Firmly fix the unit to the wall (using 2 3.9*25 screws) or in the ground (by using 2 M8 screws fix the chassis on the ground) to avoid accidental falling.

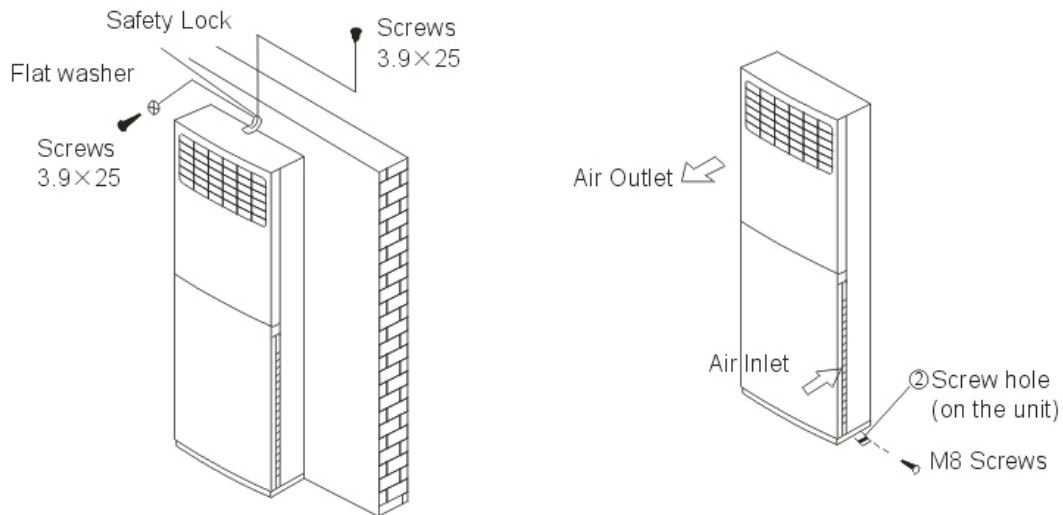

2. Dismounting the air-inlet grid

Please take off the air-inlet grid before connecting the pipes/wires.

The grid is hitched by a loop inside. To dismount the air-inlet grid, hold both sides of the grid and pull it up, let it slant downwards until the loop become straight. Then removing the screws fastened the loop with the grid, and the grid goes free.

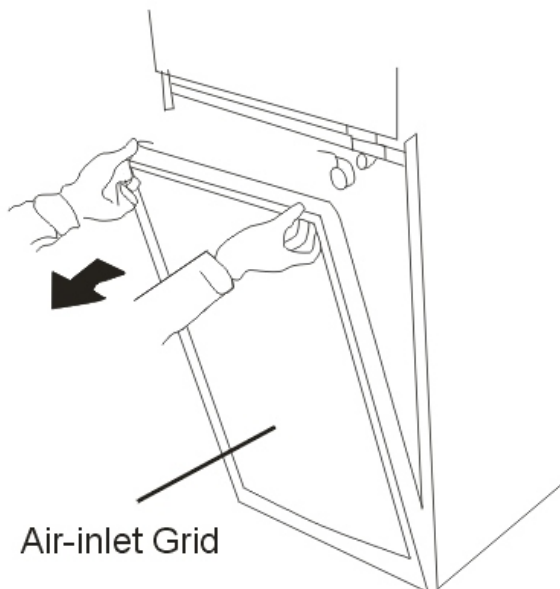

3. Take the Pipe Clip off before connecting the pipes and wiring; fit it when these finished.
Use accessories to connect the pipes/wires on both sides and back side.

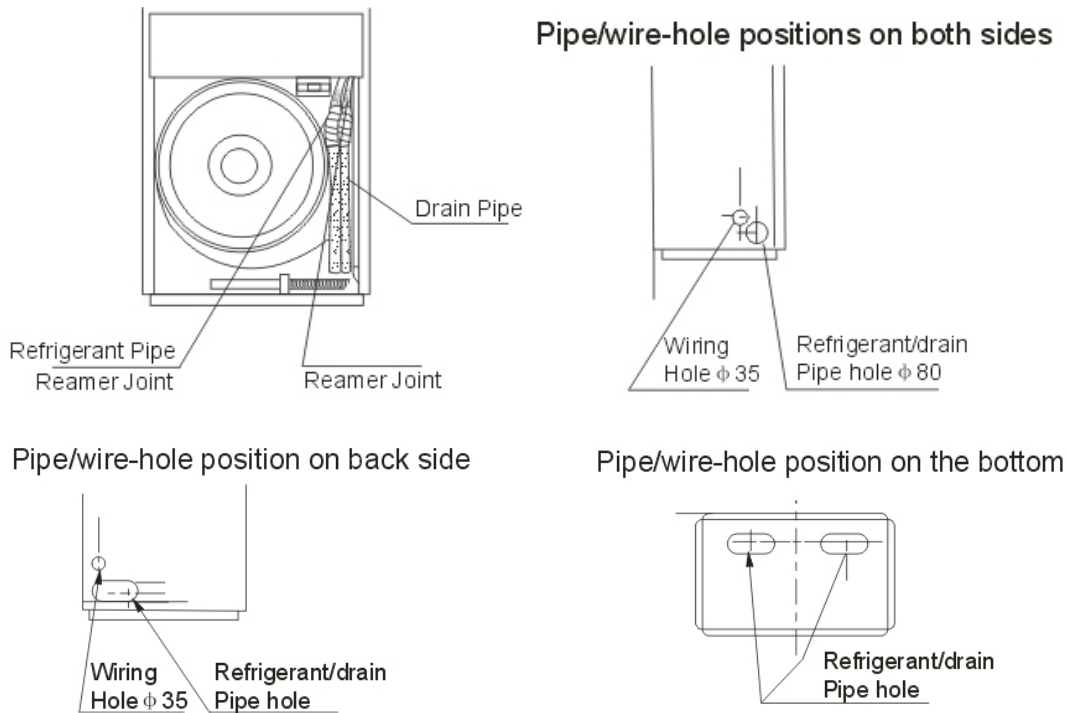

5.2.2 Outdoor Unit:

1. Ship the a/c to the installation place originally packed;
2. Be careful while hanging the unit because the center of gravity of the unit is not centralized;
3. Do not make the angle of inclination more than 45 degrees while shipping;(Avoid horizontal storage)
4. Be sure the electric insulation work is well done if installed on metal ceiling / wall.

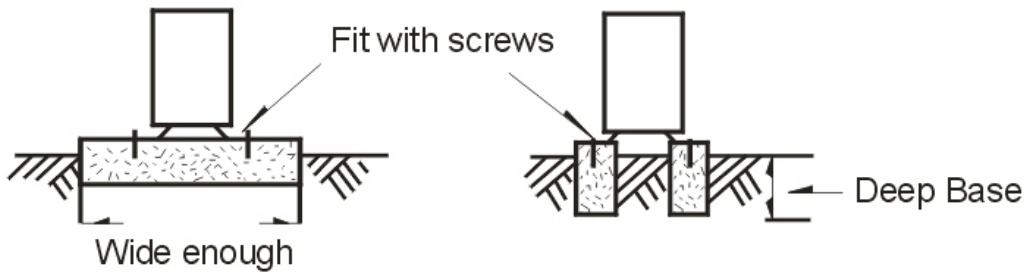

5. Fix the unit feet with bolts (M10/M8). Be sure the unit is fixed strongly enough to against blast or earthquake.
6. Make a concrete basement to the unit by the above references.

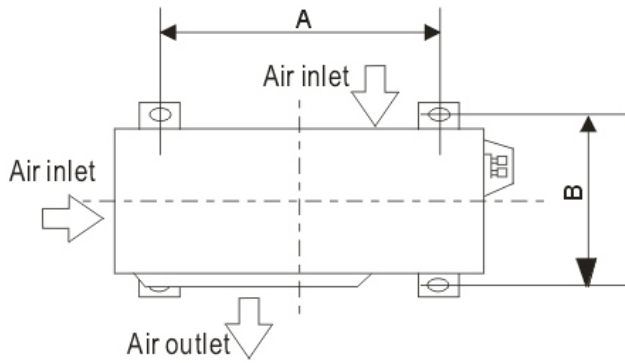

Dimension Mode	A (mm)	B (mm)
24K	560	335
42K	623	366
48K	602	380

5.3 Refrigerant pipe connection

5.3.1 Pipe length and the elevation

The correct refrigerant quantity filled in the 5-meter-long pipe of the outdoor unit is marked on the Product Data Plate. If you have to use longer pipe for every meter plus pipe, the refrigerant should be added according to the following calculation.

Capacity Btu/h	Pipe size		Standard length (m)	Max. Elevation B (m)	Max. Length A (m)	Additional refrigerant (g/m)
	Gas	Liquid				
24K	5/8" (Φ16.0)	3/8" (Φ9.52)	5	10	20	40
48K	3/4" (Φ19)	1/2" (Φ12.7)	5	15	30	60

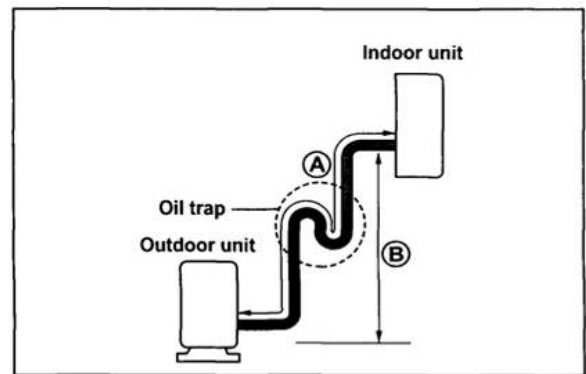
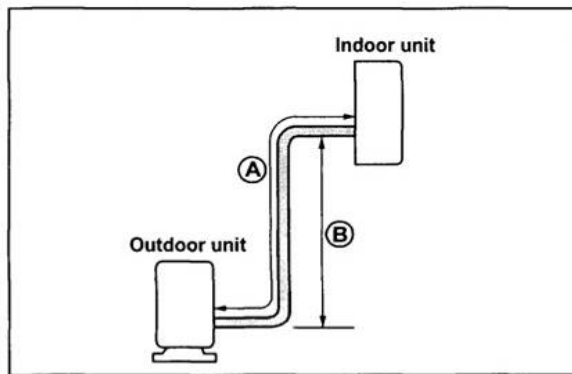

Caution:

Capacity is base on standard length and maximum allowance length is base of reliability.

Oil trap should be installed per 5-7 meters.

5.3.2 Piping connection

5.3.2.1 Connecting Of Refrigerant Pipe

- a) Only the correctly installing of indoor and outdoor unit done, can the refrigerant pipe be connected.
- b) The cut-off valves are completely close before ex-work. Before connecting the refrigerant pipe, be careful to check whether the valves are completely close.
- c) The connecting procedure of refrigerant pipe: first, unscrew the two valves on the outdoor unit and the pipe-jointing nut on the indoor unit(please keep them care fully). Please connect the refrigerant pipe according to the manual, the pipe-jointing nut should be screw tightly and no leakage. Note: you need two wrenches to make balance.
- d) When the connecting of refrigerant pipe is finished, before power on the system, you should vacuum the indoor unit through the maintenance port on the cut-off valves, or open the high-pressure valve, and exhaust the air through the maintenance port on the low-pressure valve(closed). It will take about ten seconds. Then screw tightly the maintenance port. (When supplement the refrigerant, fill through the maintenance port of the low-pressure valves on the outdoor unit).
- e) Open all the valves completely before power on the system, or it will be sick for low efficiency.
- f) Gas leak check. Make sure no gas from connections with leak detector or soap water.

Caution:

A: Lo packed valve B: Hi packed valve

C and D are ends of indoor unit connection.

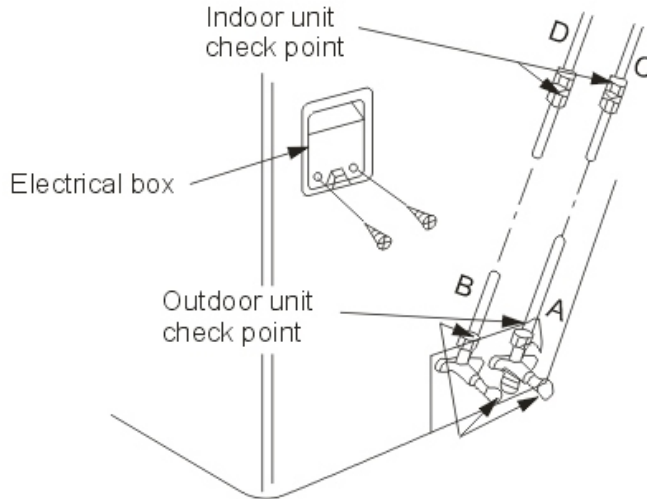

Caution in Handling the Packed Valve

- a. Open the valve stem until it hits against the stopper. Do not try to open it further.
- b. Securely tighten the valve stem cap with a spanner or the link.

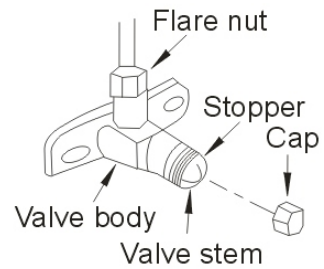
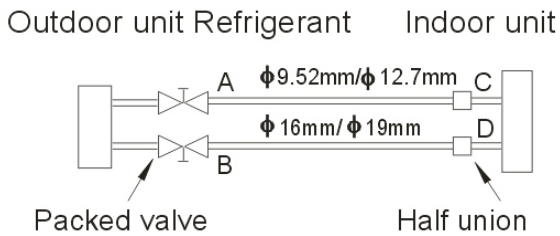

Notes for the bendable pipe

- a. The bendable pipe should be used on the indoor side;
- b. Bend angle may not exceed 90 degrees;
- c. The bend location should be made on the center of the pipe if possible, as for bend radius, the bigger the better;
- d. The bendable pipe may not be bent for more than 3 times.

Bend the thin pipe

- a. While bending, expose the pipe by cutting the concave gap on the bending heat-insulation pipe(roll it with soft band after bent).

- b. To avoid pipe deformation, the radius is the bigger the better.
- c. Use a pipe-bending device to make the compact bending pipe.

Use thumb to curve the pipe



Min. Radius 100 mm

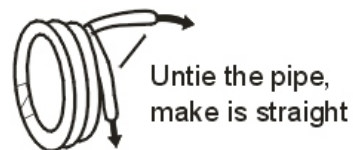

5.3.2.2 Using bronze pipe selling in market

Completely shut the cut-off valves of the outdoor unit (as ex-work status). After the refrigerant pipe has been connected with both the indoor and outdoor unit, let the air exhaust out from the maintenance gap on the low-pressure cut-off valves of the outdoor unit. Screw the nuts tightly on the maintenance gap after the air has been drained.

5.3.2.3 To make the refrigerant pipe unblocked completely

You should keep the cut-off valves of the outdoor unit completely open after you have finished the above steps (5.3.2.1 or 5.3.2.2)

Note:

1. Before screwing the reamer nut, smear the pipe and the connecting surface with refrigerant oil;
2. Check and make sure there is no leakage by soap-water or leakage-checker after connecting;
3. Be sure the connecting joint on the indoor side is insulated.
4. Use two wrenches to connecting the pipes.

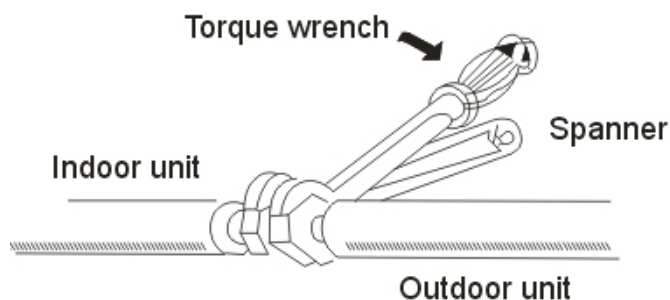

Outside diameter		Torque	Additional tightening torque
mm	inch	N.cm	N.cm
Φ9.52	3/8	3270	3990
Φ12.7	1/2	4950	6030
Φ16	5/8	6180	7750
Φ19	3/4	9720	11860

5.3.3 Air purging with vacuum pump

Air and moisture in the refrigerant system have undesirable effects as below:

- Pressure in the system rises.
- Operating current rises.
- Cooling or heating efficiency drops.
- Moisture in the refrigerant circuit may freeze and block capillary tubing.
- Water may lead to corrosion of parts in the refrigerant system.

Therefore, the indoor units and the pipes between indoor and outdoor units must be leak tested and evacuated to remove gas and moisture from the system.

Air purging with vacuum pump

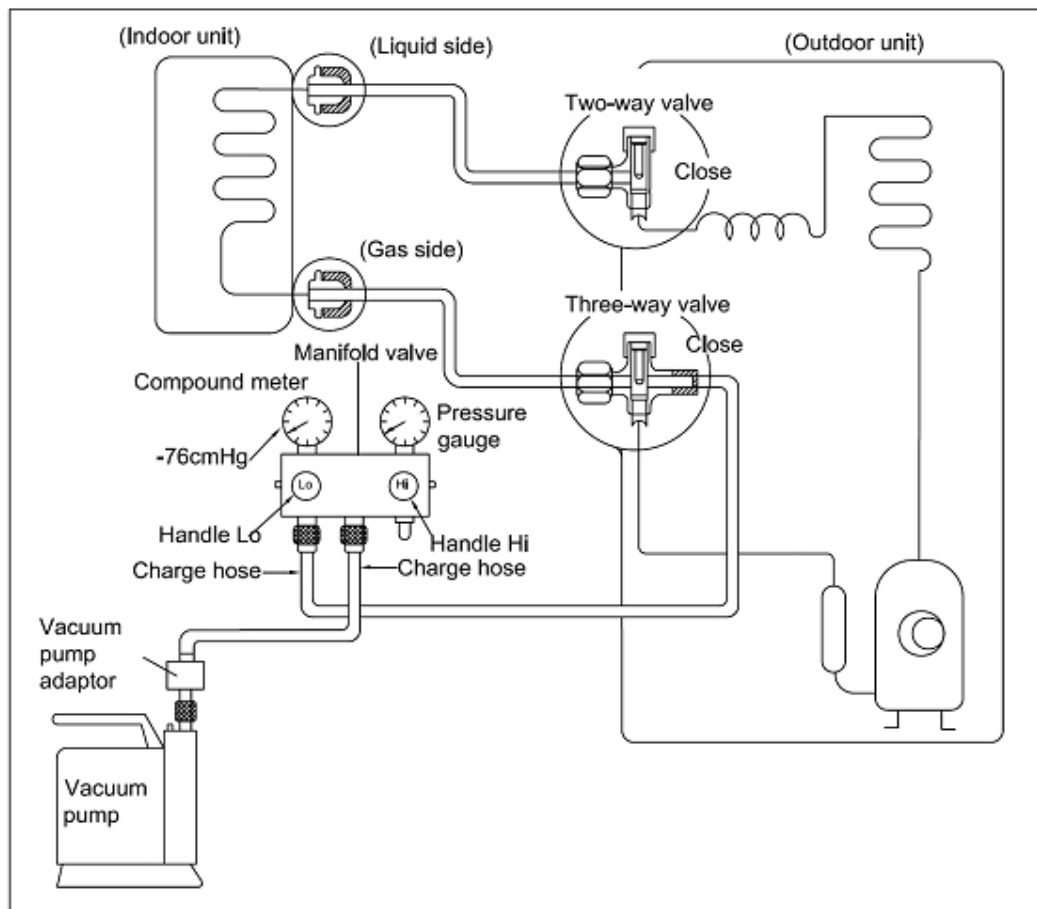

1. Completely tighten the flare nuts of the indoor and outdoor units, connect the manifold valve charge.
2. Connect the charge hose connection to the vacuum pump.
3. Fully open the handle Lo of the manifold valve.
4. Operate the vacuum pump to evacuate. After starting evacuation, slightly loose the flare nut of the Lo valve on the gas pipe side and check the air is entering. (Operation noise of the vacuum pump changes and a compound meter indicates 0 stead of minutes)
5. After the evacuation is complete, fully close the handle Lo valve of the manifold valve and stop the operation of the vacuum pump. Make evacuation for 15 minutes or more and check the compound meter indicates -76cmHg.
6. Turn the stem of the Hi valve about 45° counterclockwise for 6 or 7seconds after the gas coming out, then tighten the flare nut again. Make sure the pressure display in the pressure indicator is a little higher than the atmosphere pressure.
7. Remove the charge hose from the Lo pressure charge hose.

8. Fully open the Hi and Lo packed valve.
9. Securely tighten the cap of the packed valve.

Gas leak check

Soap water method

Apply soap water or a liquid neutral detergent on the indoor unit connections or outdoor unit connections by a soft brush to check for leakage of the connecting points of the piping. If bubbles come out, the pipes have leakage.

5.3.4 Pumping down (Re-installation)

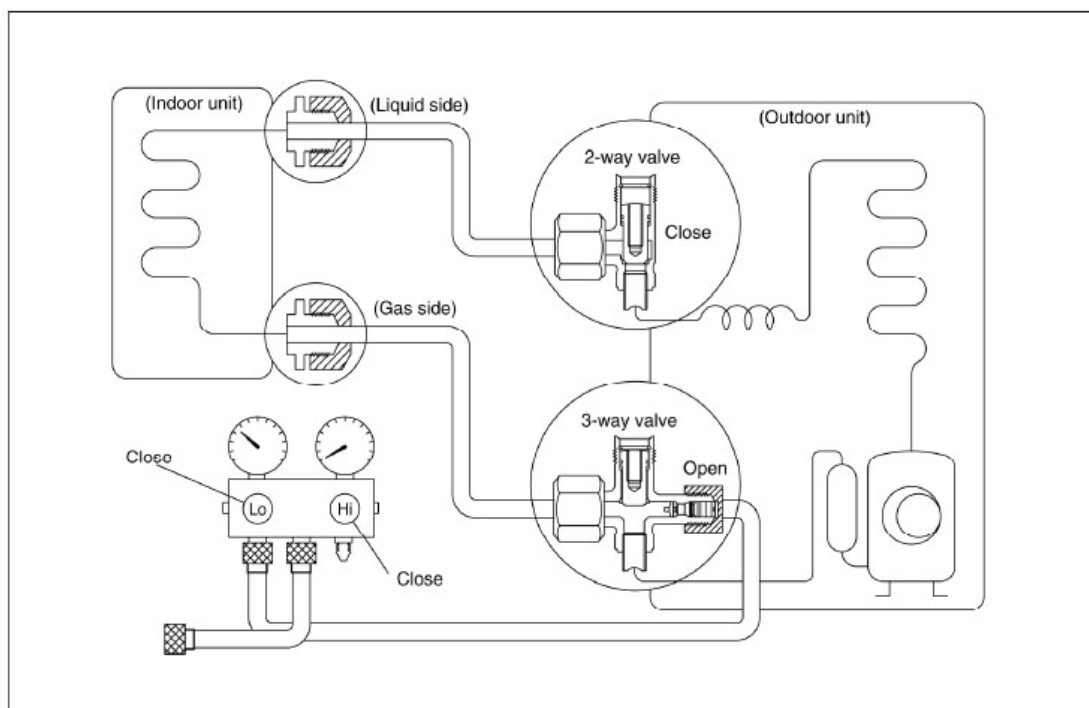

Procedure

1. Confirm that both the 2-way and 3-way valves are set to the opened position.
Remove the valve stem caps and confirm that the valve stems are in the opened position.
Be sure to use a hexagonal wrench to operate the valve stems.
2. Operate the unit for 10 to 15 minutes.
3. Stop operation and wait for 3 minutes, then connect the charge set to the service port of the 3-way valve.

Connect the charge hose with the push pin to the gas service port.

5. Air purging of the charge hose.

Open the low-pressure valve on the charge set slightly to purge air from the charge hose.

6. Set the 2-way valve to the close position.

7. Operate the air conditioner at the cooling cycle and stop it when the gauge indicates 0.1MPa.

8. Immediately set the 3-way valve to the closed position.

Do this quickly so that the gauge ends up indicating 0.3 to 0.5Mpa.

Disconnect the charge set, and amount the 2-way and 3-way valve's stem nuts and service port caps.

Use a torque wrench to tighten the service port cap to a torque of 1.8 kgf.m.

Be sure to check for gas leakage.

5.3.5 Re-air purging (Re-installation)

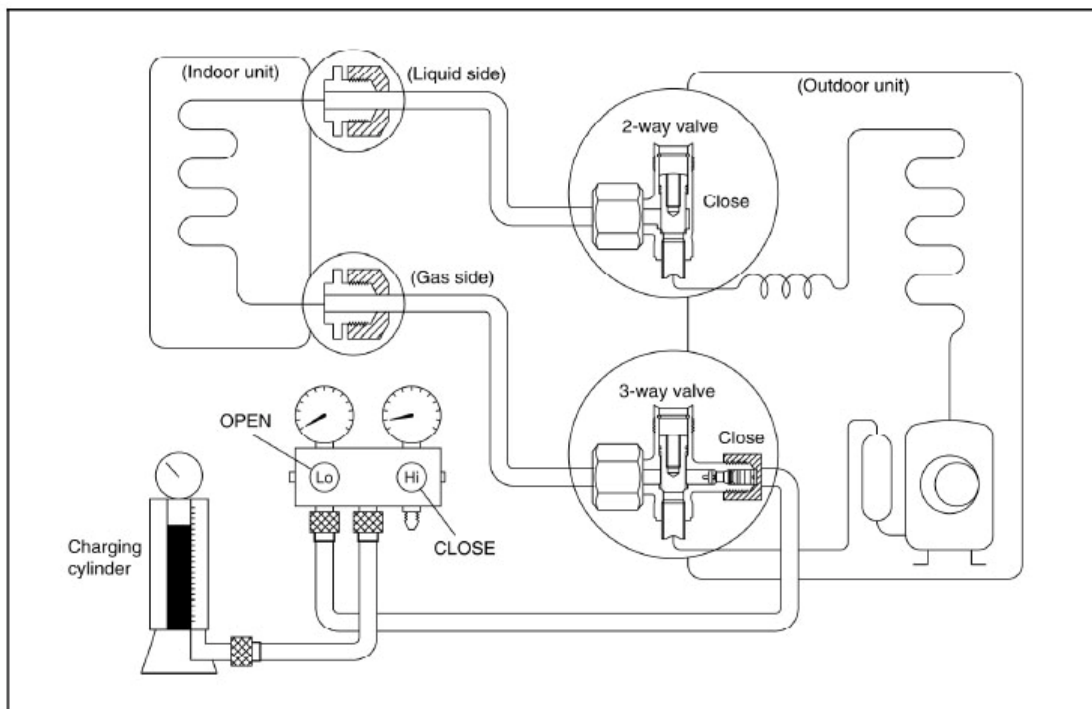

Procedure:

1. Confirm that both the 2-way and 3-way valves are set to the closed position.

2. Connect the charge set and a charging cylinder to the service port of the 3-way valve.

Leave the valve on the charging cylinder closed.

3. Air purging.

Open the valves on the charging cylinder and the charge set. Purge the air by loosening the flare nut on the 2-way valve approximately 45° for 3 seconds then closing it for 1 minute; repeat 3 times.

After purging the air, use a torque wrench to tighten the flare nut to on the 2-way valve.

4. Check the gas leakage.

Check the flare connections for gas leakage.

5. Discharge the refrigerant.

Close the valve on the charging cylinder and discharge the refrigerant until the gauge indicates 0.3 to 0.5 Mpa.

6. Disconnect the charge set and the charging cylinder, and set the 2-way and 3-way valves to the open position.

Be sure to use a hexagonal wrench to operate the valve stems.

7. Mount the valve stems nuts and the service port cap.

Be sure to use a torque wrench to tighten the service port cap to a torque 18N.m.

Be sure to check the gas leakage.

5.3.6 Balance refrigerant of the 2-way, 3-way valves

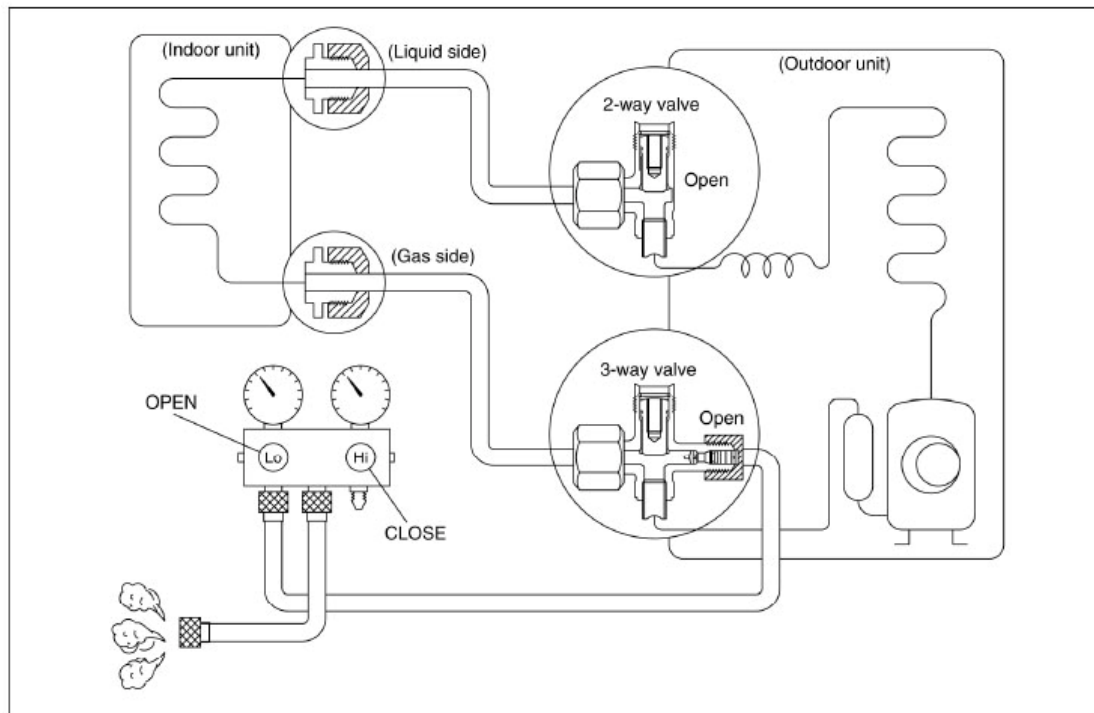

Procedure:

1. Confirm that both the 2-way and 3-way valves are set to the open position.
2. Connect the charge set to the 3-way valve's service port.

Leave the valve on the charge set closed.

Connect the charge hose with the push pin to the service port.

3. Open the valves (Low side) on the charge set and discharge the refrigerant until the gauge indicates 0.05 to 0.1Mpa.

If there is no air in the refrigeration cycle [the pressure when the air conditioner is not running is higher than 0.1Mpa, discharge the refrigerant until the gauge indicates 0.05 to 0.1 Mpa. If this is the case, it will not be necessary to apply an evacuation.

Discharge the refrigeration gradually; if it is discharged too suddenly, the refrigeration oil will be discharged.

5.3.7 Evacuation

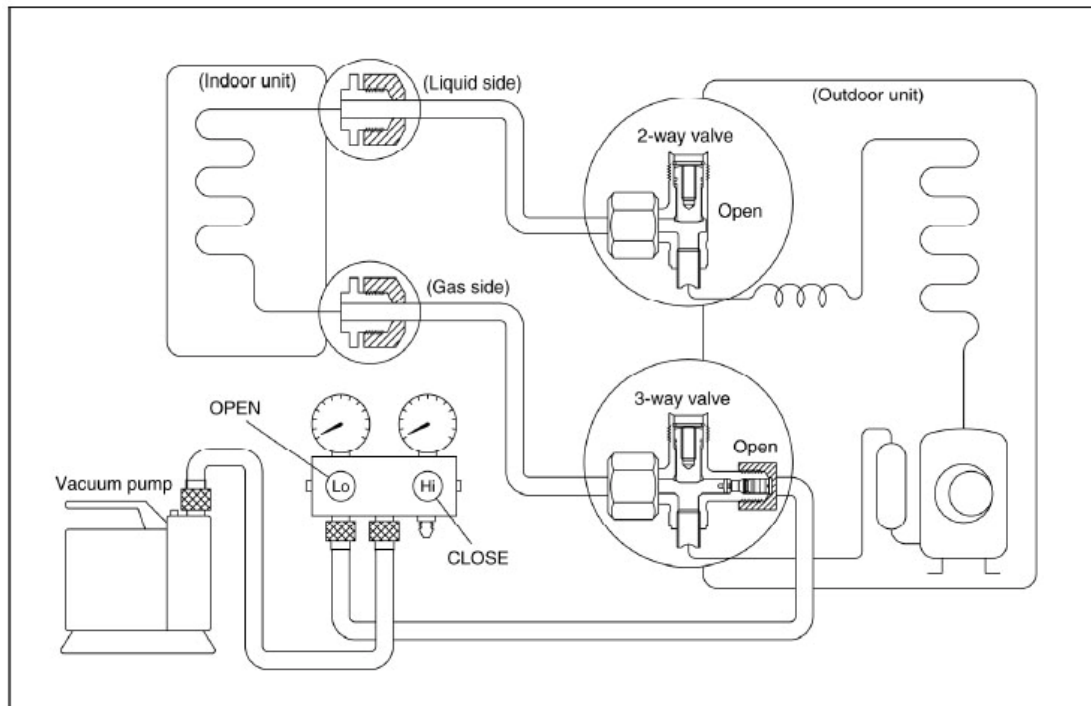

Procedure:

1. Connect the vacuum pump to the charge set's centre hose.
2. Evacuation for approximately one hour.

Confirm that the gauge needle has moved toward -0.1 Mpa (-76 cmHg) [vacuum of 4 mmHg or less].

3. Close the valve (Low side) on the charge set, turn off the vacuum pump, and confirm that the gauge needle does not move (approximately 5 minutes after turning off the vacuum pump).

4. Disconnect the charge hose from the vacuum pump.

Vacuum pump oil, if the vacuum pump oil becomes dirty or depleted, replenish as needed.

5.3.8 Gas charging

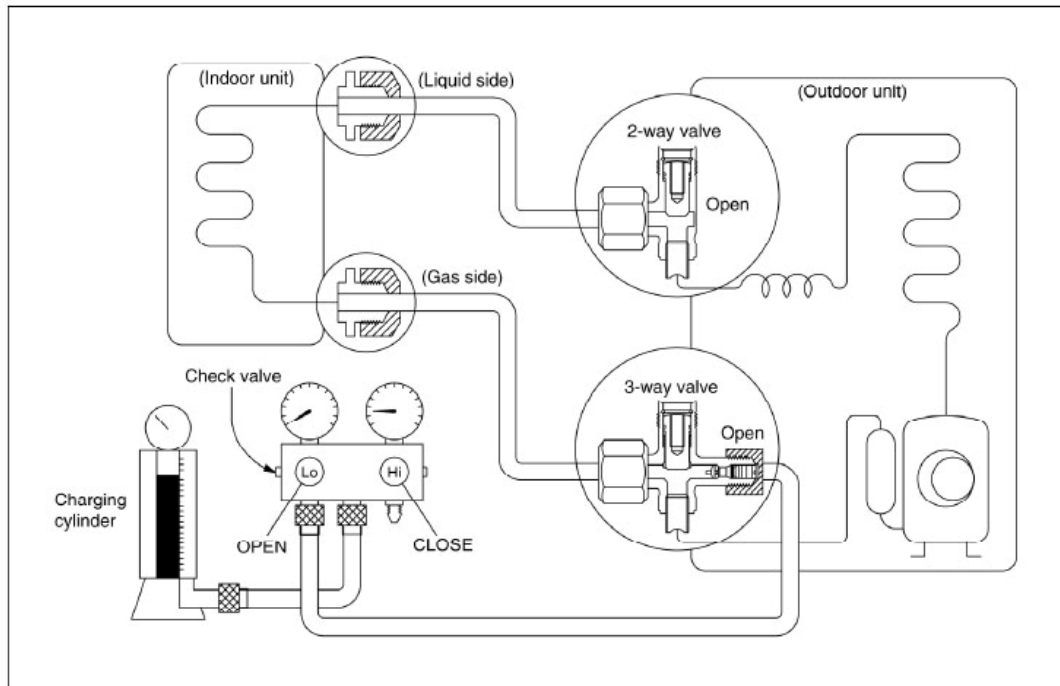

Procedure:

1. Connect the charge hose to the charging cylinder.

Connect the charge hose which you disconnected from the vacuum pump to the valve at the bottom of the cylinder. If the refrigerant is R410A, make the cylinder bottom up to ensure liquid charge.

2. Purge the air from the charge hose.

Open the valve at the bottom of the cylinder and press the check valve on the charge set to purge the air (be careful of the liquid refrigerant).

3. Open the valves (Low side) on the charge set and charge the system with liquid refrigerant.

If the system cannot be charge with the specified amount of refrigerant, it can be charged with a little at a time (approximately 150g each time) while operating the air conditioner in the cooling cycle; however, one time is not sufficient, wait approximately 1 minute and then repeat the procedure.(pumping down-pin).

4. Immediately disconnect the charge hose from the 3-way valve's service port.

Stopping partway will allow the refrigerant to be discharged.

If the system has been charged with liquid refrigerant while operating the air conditioner, turn off the air conditioner before disconnecting the hose.

5. Mounted the valve stem caps and the service port

Use torque wrench to tighten the service port cap to a torque of 18N.m.

Be sure to check for gas leakage.

5.4 Drain Pipe of The Indoor Unit

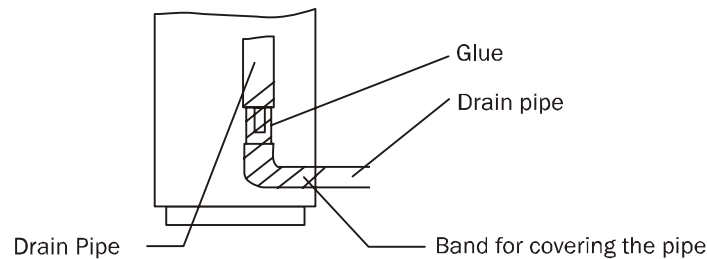

1. Make sure the drain pipe is connected to the outdoor side downward;
2. The hard polyvinyl chloride (PVC) plastic pipe (external diameter 26 mm) sold in the market is suitable for the attached soft drain pipe;
3. Please connect the Soft Drain Pipe with the Drain Pipe, then fix it with band;
4. If you have to connect the Drain Pipe indoors, to avoid condensing caused by air intake, you must cover the pipe with heat-insulation material (polyethylene with Specific Gravity of 0.03, at least 9 mm in thickness), and use Glue Band to fix it.
5. After the Drain Pipe has been connected, please check if the water drains out of the pipe efficiently and has no leakage.
6. Refrigerant pipe and Drainpipe should be heat-insulated to avoid condensing and water-dropping later on.

5.5 Wiring

Please refer to the Wiring Diagram.

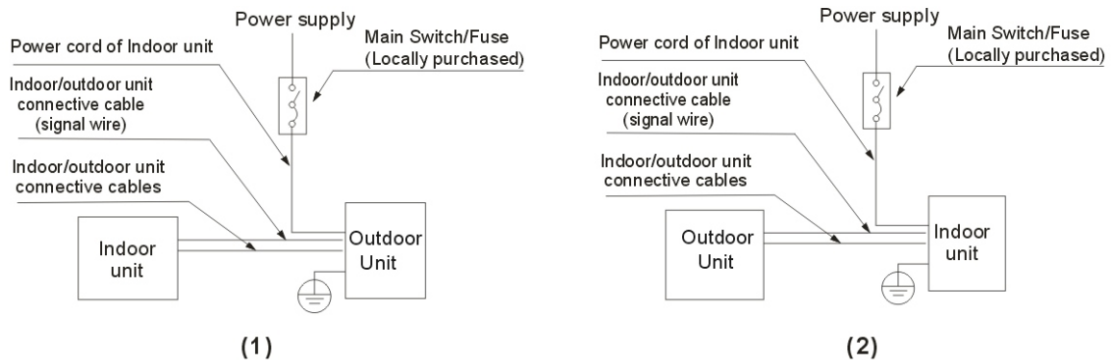

Note: The power supply of the air conditioner is different according to the models. Please refer to the WIRING DIAGRAM pasted on the indoor and outdoor units before wire connection.

5.6 Test operation

5.6.1 Perform the electric safe check after completing installation:

1. Insulated resistance

The insulated resistance must be more than 2Ω .

2. Grounding work

After finishing grounding work, measure the grounding resistance by visual detection and grounding resistance tester. Make sure the grounding resistance is less than 4Ω .

3. Electrical leakage check (performing during test running)

During test operation after finishing installation, the serviceman can use the electroprobe and multimeter to perform the electrical leakage check. Turn off the unit immediately if leakage happens. Check and find out the solution ways till the unit operate properly.

5.6.2 Perform test running operation after finishing gas leak and electrical safety check.

The test operation time should last more than 30 minutes.

1. Turn on the unit.

2. Press the TEST RUNNING button on control panel, the unit will begin TEST RUNNING operation.

3. Check if all the functions works well while in testing operation. Especially check whether the water drainage of indoor unit is smoothly or not.

4. Press the TEST RUNNING button again till the operation indicator turns dark after finishing the test operation and the unit stops operation.

6. External view and display

6.1 External view

Indoor unit

- ① Air outlet
- ② Operation panel
- ③ Horizontal airflow control louver
- ④ Vertical airflow control louver
- ⑤ Remote controller holder (on some models)
- ⑥ Air inlet (2 sides)

Outdoor unit

- ⑦ Drain pipe, vent pipe
- ⑧ Connection cable
- ⑨ Connection pipe
- ⑩ Refrigerant pipe port
- ⑪ Air outlet

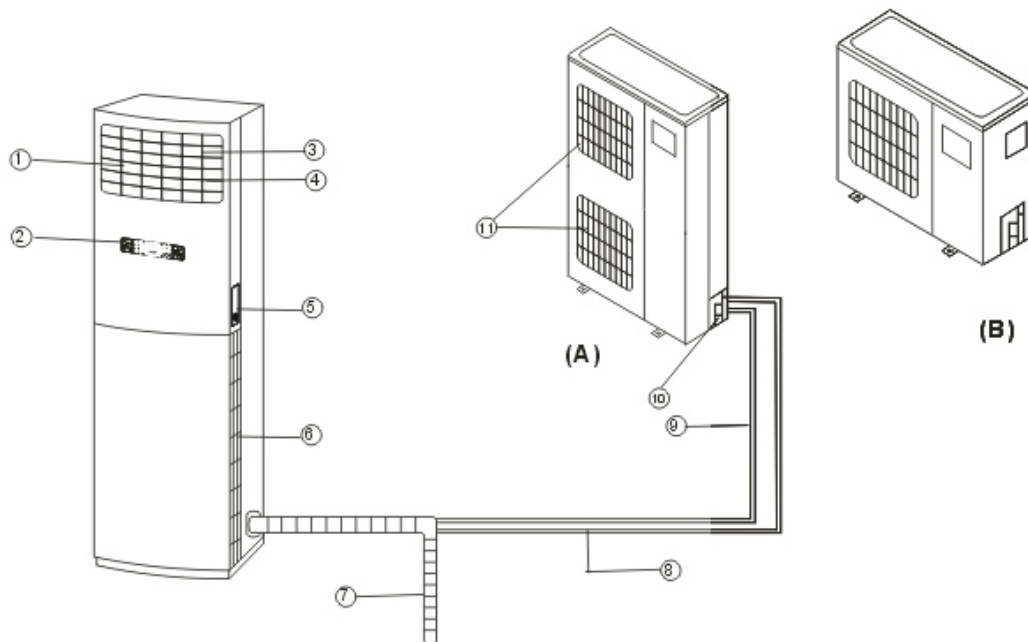

Note:

All the pictures in this manual are for explanation purpose only. They may be slightly different from the air conditioner you purchased (depend on model). The actual shape shall prevail.

6.2 Display panel

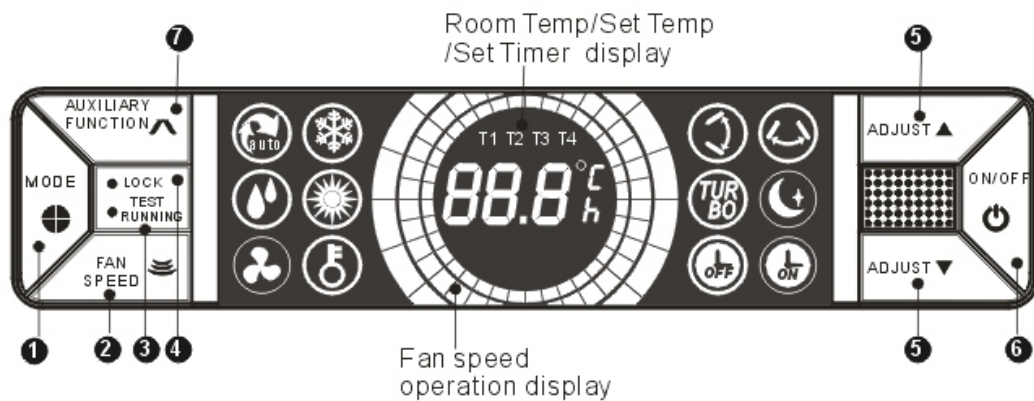

Indicators

- | | |
|---------------------------|-----------------------------|
| Auto operation display | Vertical airflow display |
| Cooling operation display | Horizontal airflow display |
| Dry operation display | Sleep operation display |
| Heating operation display | Turbo operation display |
| Fan operation display | On timer operation display |
| | Off timer operation display |
| | Lock operation display |

7. Operation characteristics

Mode Temperature	Cooling operation	Heating operation	Drying operation
Room temperature	17°C~32°C	17°C~30°C	17°C~32°C
Outdoor temperature	18°C~43°C	-7°C~24°C	18°C~ 43°C

CAUTION:

1. If air conditioner is used outside of the above conditions, certain safety protection features may come into operation and cause the unit to function abnormally.

2. Room relative humidity less than 80%. If the air conditioner operates in excess of this figure, the surface of the air conditioner may attract condensation. Please sets the vertical air flow louver to its maximum angle (vertically to the floor), and set HIGH fan

mode.

3. Optimum performance will be achieved within this operating temperature.

8. Electronic function

8.1 Main data Introduction

Ts : Set temperature,

T1 : Room temperature

T2: Evaporator pipe temperature

T3: Condenser pipe temperature

T4: Outdoor ambient temperature

8.2 Operation Modes and Functions

8.2.1 Manual Operation

8.2.2 Heating Mode

8.2.2.1 Four-way valve opens at once , while defrosting process closes.

8.2.2.2 Condition for the compressor action: (Ts=set temperature, T1=room temperature)

	Condition	Compressor and outdoor fan
Room temperature up	$T1-Ts > 0^{\circ}\text{C}$	Off
	$T1-Ts < 0^{\circ}\text{C}$	On
Room temperature down	$T1-Ts < -1^{\circ}\text{C}$	On
	$T1-Ts > -1^{\circ}\text{C}$	Off

8.2.2.3 Indoor Fan Action

Anytime remote switchover for fan speed among high/low/auto, anti-cold air function takes priority.

Auto fan in heating mode

	Condition	Fan speed
Room temperature up	$T1-Ts > -1^{\circ}\text{C}$	Low
	$T1-Ts < -1^{\circ}\text{C}$	Hi.
Room temperature down	$T1-Ts < -2^{\circ}\text{C}$	Hi.
	$T1-Ts > -2^{\circ}\text{C}$	Low

8.2.2.5 Anti-cold air:

Switchover between fan speed and fine tune can be set according to temperature of evaporator pipe (T2).

	Condition	Fan speed
Room temperature up	$T2 < 25^{\circ}\text{C}$	Off
	$25^{\circ}\text{C} < T2 < 32^{\circ}\text{C}$	Low
	$T2 > 32^{\circ}\text{C}$	Set fan speed
Room temperature down	$T2 > 22^{\circ}\text{C}$	Set fan speed
	$20^{\circ}\text{C} < T2 < 22^{\circ}\text{C}$	Low
	$T2 < 20^{\circ}\text{C}$	Off

8.2.2.6 Electric heating string(only for 48K)

Electric heating string in heating mode

Compressor	Condition	Electric heating string
On	/	Off
Off	Outdoor temperature $< 5^{\circ}\text{C}$	On
Off	Outdoor temperature $> 7^{\circ}\text{C}$	Off

8.2.3 Defrost (only available to heating mode)

8.2.3.1 Defrosting Conditions

Starting Of Defrosting Condition (meet one of the following is ok):

(1) Accumulated time when temperature of outdoor heat exchanger coil T3 is below 3°C reaches to 40 minutes, then consecutive 3 minutes less than -5 degrees (Just for the AC is turn on , whether or not the heating mode the temperature was detected, start to statistical time when reach the temperature condition . Shut down or defrosting calculate time again).

(2) Accumulated time when temperature of outdoor heat exchanger coil T3 is below 3°C reaches to 60 minutes, then consecutive 3 minutes less than -4 degrees (Just for the AC is turn on , whether or not the heating mode the temperature was detected, start to statistical time when reach the temperature condition . Shut down or defrosting calculate time again).

(3) Accumulated time when temperature of outdoor heat exchanger coil T3 is below 3°C reaches to 80 minutes, then consecutive 3 minutes less than -2 degrees (Just for the AC is turn on , whether or not the heating mode the temperature was detected, start to statistical time when reach the temperature condition . Shut down or defrosting calculate time again).

(4) Under evaporator high temperature protection, the accumulated time when outdoor fan motor is off and compressor is on reaches up to over 90 minutes .(Shut down or defrosting or T3 is over 15°C , calculate time again.)

8.2.3.2 Defrosting Action

Four-way valve, indoor fan, outdoor fan are shut down. Compressor keeps on.

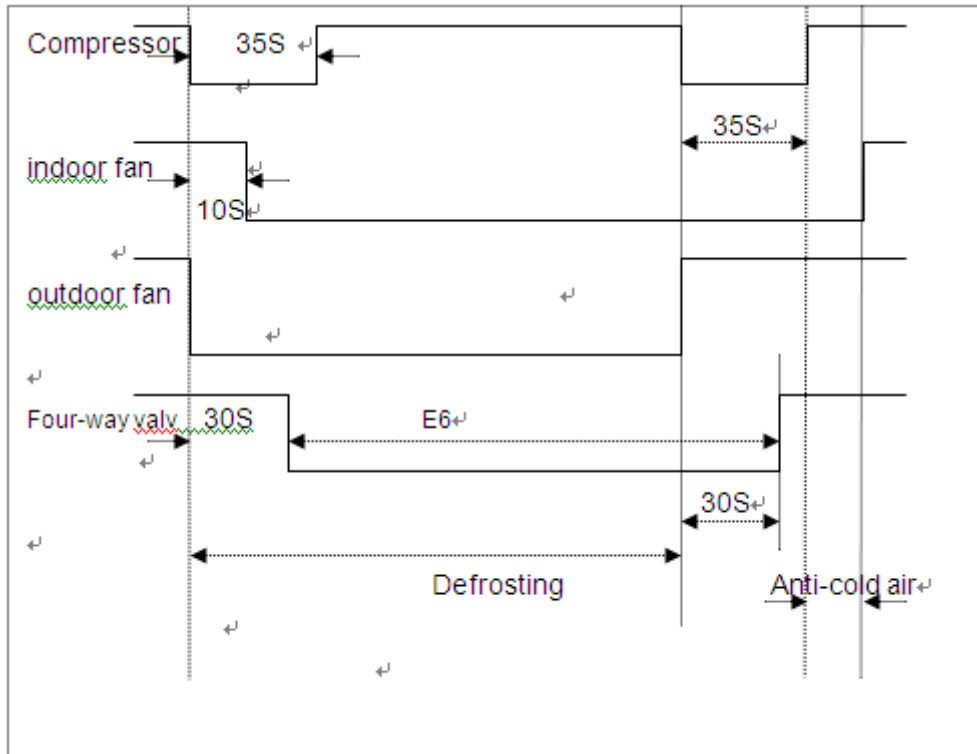

8.2.3.3 Ending Of Defrosting Condition (meet one of the following is ok):

- (1) Time of defrosting lasts 10 minutes.
- (2) Temperature of outdoor coil T3 is up to 8°C and continues to 80 seconds.
- (3) Temperature of outdoor coil T3 is up to 15°C.

8.2.4 Cooling Mode

8.2.4.1 Four-way valve is closed.

If four-way valve is open before the machine enters cooling mode, then four-way valve will be closed at the first time, the compressor starts under the cooling mode.

8.2.4.2 Conditions for the compressor and outdoor fan action (T_s = set temperature)

	Condition	Compressor and outdoor fan
Room temperature up	$T1 - T_s < 1^\circ\text{C}$	Off
	$T1 - T_s > 1^\circ\text{C}$	On
Room temperature down	$T1 - T_s > 0^\circ\text{C}$	On
	$T1 - T_s < 0^\circ\text{C}$	Off

8.2.4.3 Action of Indoor Fan

HIGH/MED/LOW/AUTO fan can be switched over by your comfort.

Auto fan under cooling mode.

	Condition	Fan speed
Room temperature up	$T1 - T_s > 2^\circ\text{C}$	Hi.
	$T1 - T_s < 2^\circ\text{C}$	Low
Room temperature down	$T1 - T_s < 1^\circ\text{C}$	Low
	$T1 - T_s > 1^\circ\text{C}$	Hi.

8.2.5 Dehumidifying Mode

8.2.5.1 Indoor fan speed is low.

8.2.5.2 Four-way valve is closed, the compressor and outdoor fan will keep as same as cooling mode.

8.2.6 Auto Mode

8.2.6.1. Under auto mode, the indoor fan is set to be auto and the temperature is 24°C.

8.2.6.2 When entering auto mode, the heating, fan only or cooling operation will be automatically chosen according to the room temperature T1 and the set temperature Ts.

Condition	Mode
$T1-Ts > 1^{\circ}\text{C}$	Cooling
$-1^{\circ}\text{C} \leq T1-Ts \leq 1^{\circ}\text{C}$	Fan
$T1-Ts < -1^{\circ}\text{C}$	Heating(fan for cooling only type)

8.2.6.3. If certain condition is met, then the corresponding protective function will be executed.

8.2.7 Fan Only Mode

8.2.7.1 Under this mode, four-way valve, compressor and outdoor fan are shut down.

8.2.7.2 High/Low/Auto fan can be switched over through manual control. Auto fan will be controlled in line with cooling auto fan with temperature set to be 24°C.

8.3 Other Functions

8.3.1 LCD display

Mode, Set temp., fan speed, time, timer, protection etc.

8.3.2 Timer

The machine should be provided with max. Interval of 24h and min. resolution ratio of 30 minutes.

9. Characteristic of temperature sensor

Temp. °C	Resistance KΩ	Temp. °C	Resistance KΩ	Temp. °C	Resistance KΩ
-10	62.2756	17	14.6181	44	4.3874
-9	58.7079	18	13.918	45	4.2126
-8	56.3694	19	13.2631	46	4.0459
-7	52.2438	20	12.6431	47	3.8867
-6	49.3161	21	12.0561	48	3.7348
-5	46.5725	22	11.5	49	3.5896
-4	44	23	10.9731	50	3.451
-3	41.5878	24	10.4736	51	3.3185
-2	39.8239	25	10	52	3.1918
-1	37.1988	26	9.5507	53	3.0707
0	35.2024	27	9.1245	54	2.959
1	33.3269	28	8.7198	55	2.8442
2	31.5635	29	8.3357	56	2.7382
3	29.9058	30	7.9708	57	2.6368
4	28.3459	31	7.6241	58	2.5397
5	26.8778	32	7.2946	59	2.4468
6	25.4954	33	6.9814	60	2.3577
7	24.1932	34	6.6835	61	2.2725
8	22.5662	35	6.4002	62	2.1907
9	21.8094	36	6.1306	63	2.1124
10	20.7184	37	5.8736	64	2.0373
11	19.6891	38	5.6296	65	1.9653
12	18.7177	39	5.3969	66	1.8963
13	17.8005	40	5.1752	67	1.83
14	16.9341	41	4.9639	68	1.7665
15	16.1156	42	4.7625	69	1.7055
16	15.3418	43	4.5705	70	1.6469

10. Trouble shooting

10.1 Protective Function

10.1.1 3-minute delay for the compressor start-up

At the beginning of energizing or after the stop of the compressor, 3-minute delay will be needed to start the compressor.

When switching over between cooling/heating/dehumidifying mode, the compressor stops automatically.

10.1.2 Evaporator protection against high temperature

10.1.2.1 Only available under heating mode.

10.1.2.2 The operation principle is as follows: (T2 = evaporator temperature)

	Condition	Outdoor fan	Compressor
Room temperature up	T2>56°C	Off	On
	T2>62°C	Off	Off
Room temperature down	T2>50°C	Off	Off
	T2<50°C	On	On

10.1.3 Evaporator Protection against low temperature

10.1.3.1 Only available under cooling and dehumidifying status.

10.1.3.2 Protection principle:

Condition	Outdoor fan	Compressor
T2≤2°C (last 3 minute)	Off	Off
T2≥8°C	On	On

10.1.3.3 The restart of the compressor shall execute the delay protection.

10.1.4 Condenser high temperature protection

10.1.4.1 Only available to cooling and dehumidifying mode.

10.1.4.2 Action condition

Condition	Outdoor fan	Compressor
Condenser temp.≥62°C (last 3 seconds)	Off	Off
Condenser temp.<48°C	On	On

10.1.4.3 Delay protection should be performed when the compressor restarts.

10.1.5 Outdoor protection(24K)

When outdoor protection signal is high level, outdoor unit will perform protection: the whole machine will be shut down while the indoor unit will indicate the corresponding protection signal.

The A/C will recover if outdoor errors are eliminated after the outdoor protection occurs.

10.2 Self-diagnosis

Codes	Contents
P4	Protection of temperature of indoor evaporator
P5	Protection of temperature of outdoor condenser
P7	Discharge temperature of outdoor unit is too high, compressor protection occurs.
P9	Protection of anti-cold wind
P10	Discharge pressure protection
P11	Suction pressure protection
P12	Current overload protection
E1	Open-circuit and short-circuit of indoor temperature sensors T1
E2	Temp. sensor T2 on indoor evaporator is open circuit or short circuit
E3	The condenser temperature sensor T3 is open or short
E4	Open-circuit and short-circuit of outdoor temperature sensors T4
E5	Communication between indoor and outdoor units failure
E6	Protection of outdoor unit
E10	Suction pressure failure of compressor
E13	Default phase of compressor
E14	Phase incorrect connection of compressor
HS	Defrosting starts

10.3 LEDs for the indication of outdoor trouble(only for 42K)

In normal operation, LEDs emit no light and they will flash at a frequency of 5 Hz when trouble occurs. Their codes are listed in the following table:

Type	LED1	LED2	LED3	Contents	Indication
Trouble	Off	Off	On	OK	E6
Trouble	On	Off	On	Phase sequence error	E6
Trouble	Off	On	On	Overload of current	E6
Trouble	On	On	On	Lack of phase	E6
Trouble	flash at a frequency of 1 Hz	Off	On	Suction pressure protection	E6

10.4 Troubles and Solutions

Before calling for service, please review the following list of common problems and solutions.

Problem	Possible Cause	Solutions
Air conditioner does not operate at all	Power failure	Wait for power restoring
	The power supply is disconnected.	Switch on the main power switch
	The power fuse is blown.	Change the fuse
	The timer is set.	Wait or cancel timer setting
	The batteries of the remote control are exhausted	Change the batteries.
Air conditioner does not cool or heat well	The temperature setting is too high or too low.	Set a more comfortable temperature.
	The air filter is clogged with dust	Clean the filter
	The air inlet or outlet of the outdoor unit is blocked	Clear up the block
	Doors or windows are open	Close the doors or windows
Air conditioner does not cool or heat at all	The air inlet or outlet of the outdoor unit is blocked	Clear up the block first, then begin to operate.
	Three-minute protection feature	Wait for a while
	Unappropriated temperature setting	Set the temperature properly

If you still cannot solve the problem after trying the above, pull out the power plug and call the dealer.

The following displays indicate an error or problem (24K) :

Number	Display code	Problems	What to do
1	E1, E2, E3	Temperature Sensor is off or short-circuit.	Contact service people
2	P4	The temperature of the indoor unit evaporator is extremely low or high , and a compressor protection feature is automatically activated.	Turn off the unit, clean the air filter, then restart the unit. If this operation does not work, please contact service people.
3	P5	The temperature of outdoor unit condenser is too high, and a compressor protection feature is automatically activated.	Turn off the unit, check if there is any obstacle in the air-inlet, otherwise call the service people.
4	P9	Anti-cold air function happens	When the temperature is warm enough, the function stops automati-cally.

The following displays indicate an error or problem (42K) :

Number	Display code	Problems	What to do
1	E1, E2, E3	Temperature Sensor is off or short-circuit.	Contact service people
2	E6	Outdoor unit protection	Contact service people
3	P4	The temperature of the indoor unit evaporator is extremely low or high , and a compressor protection feature is automatically activated.	Turn off the unit, clean the air filter, then restart the unit. If this operation does not work, please contact service people.
4	P5	The temperature of outdoor unit condenser is too high, and a compressor protection feature is automatically activated.	Turn off the unit, check if there is any obstacle in the air-inlet, otherwise call the service people.
5	P9	Anti-cold air function happens	When the temperature is warm enough, the function stops automati-cally.

The following displays indicate an error or problem (48K) :

Number	Display code	Problems	What to do
1	E1, E2, E3, E4	Temperature Sensor is off or short-circuit.	Contact service people
2	E5	Communication between indoor and outdoor units failure	Contact service people
3	E10	Suction pressure failure of compressor	Contact service people
4	E13	Default phase of compressor	Contact service people
5	E14	Phase incorrect connection of compressor	Contact service people
6	P4	The temperature of the indoor unit evaporator is extremely low or high , and a compressor protection feature is automatically activated.	Turn off the unit, clean the air filter, then restart the unit. If this operation does not work, please contact service people.
7	P5	The temperature of outdoor unit condenser is too high, and a compressor protection feature is automatically activated.	Turn off the unit, check if there is any obstacle in the air-inlet, otherwise call the service people.
8	P7	Discharge temperature of outdoor unit is too high, compressor protection occurs.	Contact service people
9	P9	Anti-cold air function happens	When the temperature is warm enough, the function stops automati-cally.
10	P10	Suction pressure protection	Contact service people
11	P11	Discharge pressure protection	Contact service people
12	P12	Current overload protection	Contact service people
13	HS	Defrosting starts	The unit will auto restart after finishing the defrosting and the temperature of indoor Heat Exchanger raises.

CAUTION: 1.If the supply cord of this appliance is damaged, replacement work shall be performed by authorized personnel only.

2. For the unit adopts PTC, the PTC heater is fixed in the middle of bottom of the cabinet. Do not attempt to remove or repair the components by yourself, it may cause a fire or other danger.