



AIRCONDITIONER FLOOR STANDING TYPE

SERVICE MANUAL

RS-FS60AB/RU-60AC3

CONTENTS

1. Safety Precautions	1
1.1 Precaution.....	1
1.2 Installation.....	1
1.3 Caution	1
1.4 Operational	2
2. Dimension	3
2.1 Indoor Unit	3
2.2 Outdoor Unit	4
3. Refrigerant cycle diagram	4
3.1 Heat pump mode	4
4. Wiring diagram	5
4.1 RS-FS60AB	5
5. Installation details	6
5.1 Installation place	6
5.2 Installing	8
5.3 Refrigerant pipe connection	10
5.4 Drain Pipe of The Indoor Unit.....	21
5.5 Wiring	22
5.6 TEST RUN	22
6. External view and display	23
6.1 PARTS NAMES	23
6.2 CONT ROL PANEL	24
6.3 LED	25
7. Operation characteristics	26
8. Electronic function	26
8.1 Main data Introduction	26

8.2	Operation Modes and Functions	26
8.3	Other Functions	29
9.	Characteristic of temperature sensor	30
10.	Trouble shooting.....	30
10.1	Protective Function	30
10.2	Self-diagnosis	32
10.3	LEDs for the indication of outdoor trouble.....	32
10.4	Troubles and Solutions	33

1. Safety Precautions

1.1 Precaution

To prevent injury to the user or other people and property damage, the following instructions must be followed.

Incorrect operation due to ignoring instruction will cause harm or damage.

Before service unit, be sure to read this service manual at first.

1.2 Installation

For electrical work, contact the dealer, seller, a qualified electrician, or an Authorized service center.

Do not disassemble or repair the product by yourself.

Sharp edges could cause injury, be especially careful of the case edges and the fins on the condenser and evaporator.

Be sure the installation area does not deteriorate with age.

Take care to ensure that power cable could not be pulled out or damaged during operation.

Do not place anything on the power cable.

Do not plug or unplug the power supply plug during operation.

Do not store or use flammable gas or combustible near the product.

When flammable gas leaks, turn off the gas and open a window for ventilation before turn the product on.

If strange sounds, or small or smoke comes from product. Turn the breaker off or disconnect the power supply cable as soon as possible.

When the product is soaked (flooded or submerged), contact an Authorized service center.

Be caution that water could not enter the product.

Turn the main power off when cleaning or maintaining the product.

When the product is not be used for a long time, disconnect the power supply plug or turn off the breaker.

1.3 Caution

Always check for gas (refrigerant) leakage after installation or repair of product.

Install the drain hose to ensure that water is drained away properly.

Keep level even when installing the product.

Do not install the product where the noise or hot air from the outdoor unit could damage the neighborhoods.

Use two or more people to lift and transport the product.

Do not install the product where it will be exposed to sea wind (salt spray) directly.

1.4 Operational

Do not expose the skin directly to cool air for long periods of time. (Do not sit in the draft).

Do not use the product for special purposes, such as preserving foods, works of art, etc. It is a consumer air conditioner, not a precision refrigerant system.

Do not block the inlet or outlet of air flow.

Use a soft cloth to clean. Do not use harsh detergents, solvents, etc.

Do not touch the metal parts of the product when removing the air filter. They are very sharp.

Do not step on or put anything on the product. (outdoor units)

Always insert the filter securely. Clean the filter every two weeks or more often if necessary.

Do not insert hands or other object through air inlet or outlet while the product is operated.

Do not drink the water drained from the product.

Use a firm stool or ladder when cleaning or maintaining the product.

2. Dimension

2.1 Indoor Unit

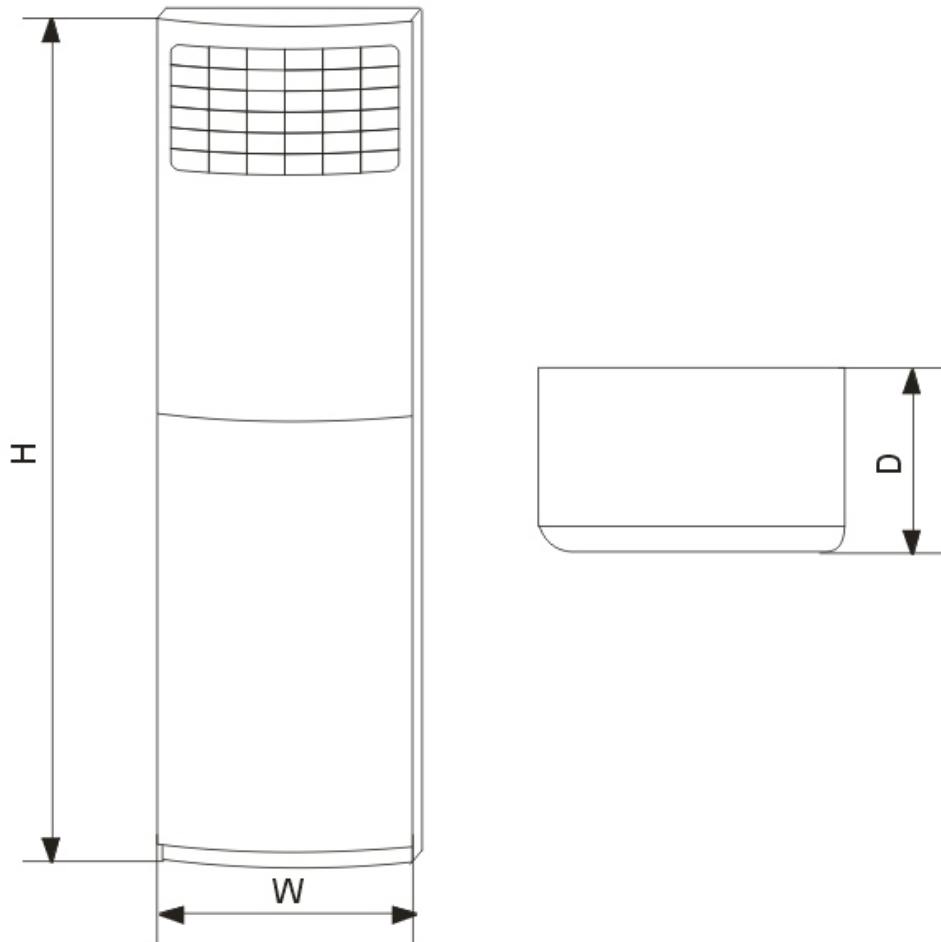

Dimension Mode	W (mm)	D (mm)	H (mm)
55K	600	358	1900

2.2 Outdoor Unit

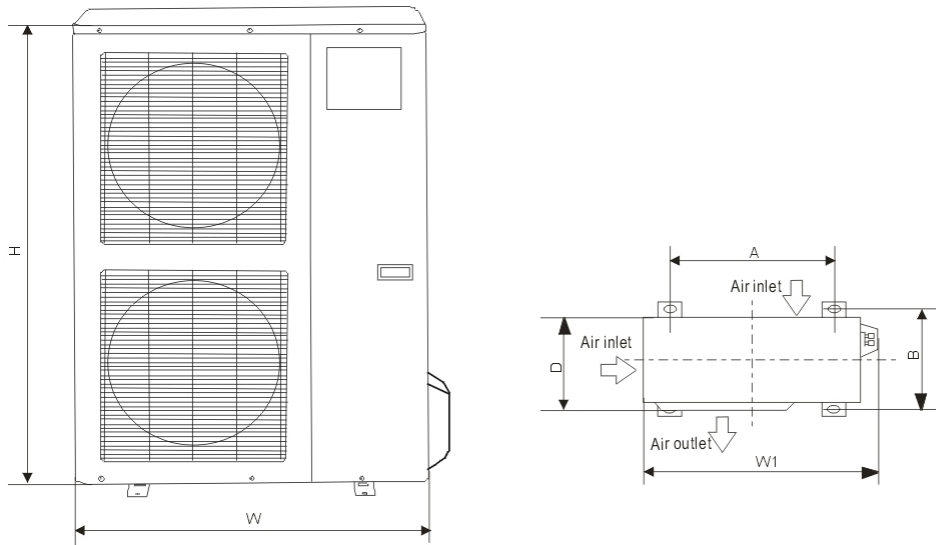

Dimension	W	D	H	W1	A	B
Mode	(mm)	(mm)	(mm)	(mm)	(mm)	(mm)
55K	940	360	1245	1020	602	380

3. Refrigerant cycle diagram

3.1 Heat pump mode

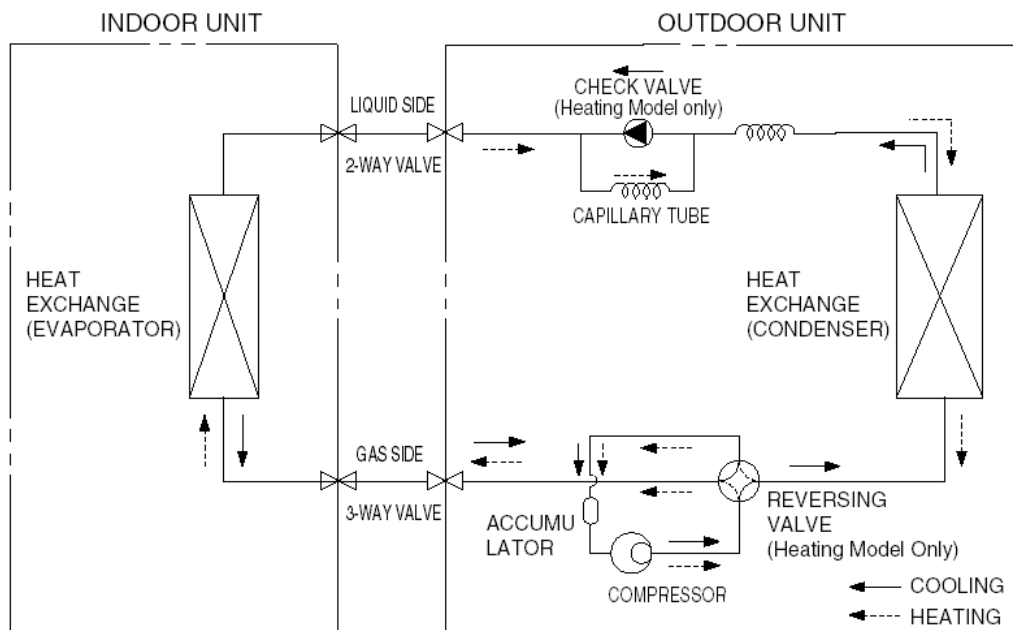

4. Wiring diagram

4.1 RS-FS60AB

Indoor Unit

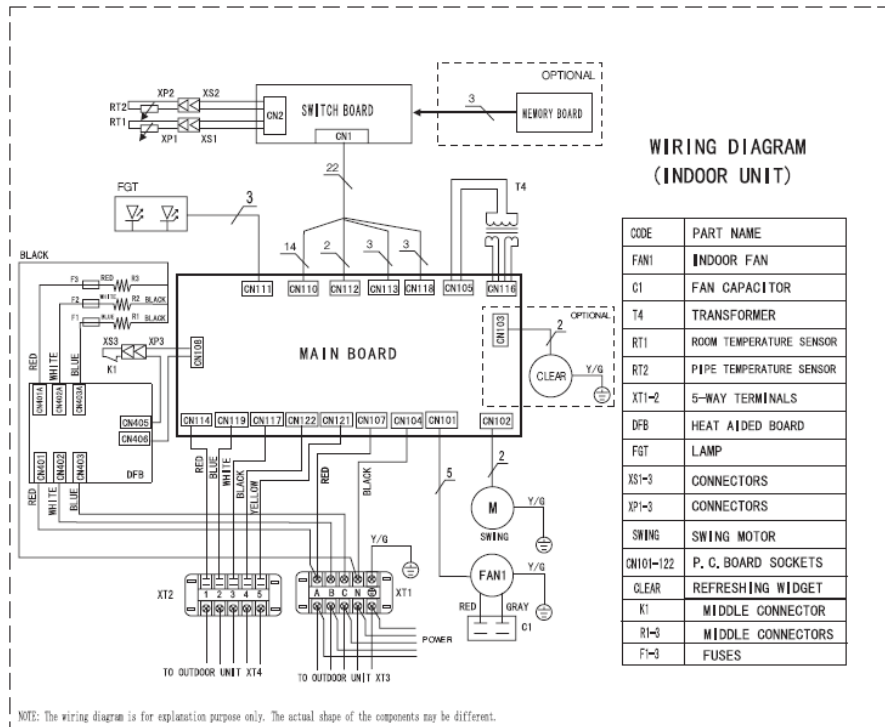

Outdoor Unit

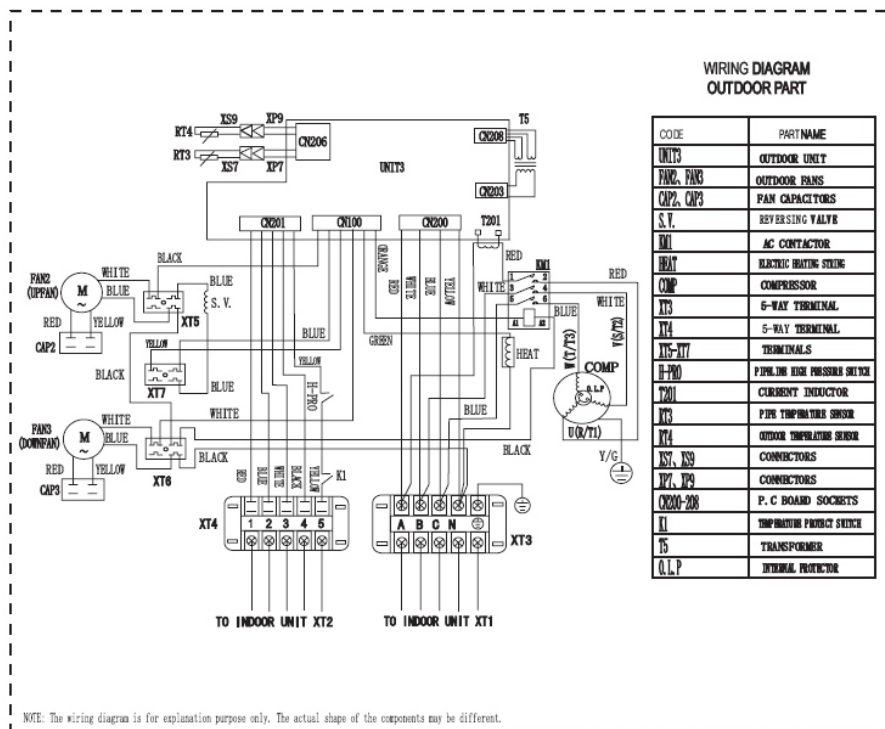

5. Installation details

5.1 Installation place

5.1.1 Indoor Unit

- a. Ensure the spaces indicated by arrows from the wall, ceiling, fence or other obstacles.
- b. There should not be any heat source or steam near the unit.
- c. There should not be any obstacles blocking the air circulation.
- d. A place where air circulation in the room is good.
- e. A place where drainage can be easily done.
- f. Do not install the unit near the door way.
- g. There should not be any direct sunlight. Otherwise, the sun will fade the plastic cabinet and affect its appearance. If unavoidable, sunlight prevention should be taken into consideration.

5.1.1.1 Please stand the unit in hard and flat ground;

Please reserve space for installation and maintenance.

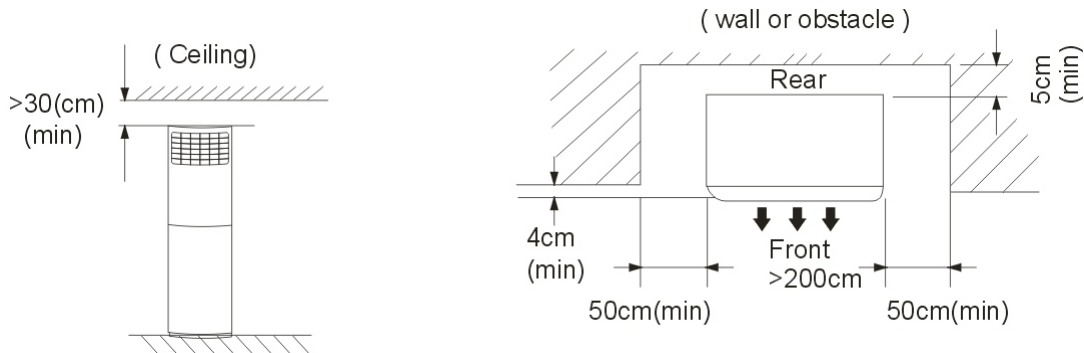

5.1.1.2 Please check the elevation difference between the indoor unit and the outdoor unit, the length of the refrigerant pipe, and the curved places (bend) of the pipe are no more than the following numbers:

Elevation difference: no more than 15M (if the elevation difference between indoor and outdoor unit is more than 15 meters, it is recommended that the indoor unit be located higher than the outdoor unit.)

Pipe length: no more than 30M

Bends: no more than 3 places.

5.1.2 Outdoor Unit

The outdoor unit should be put in a position that guarantees the minimum space for sufficient air circulation and to allow maintenance work and the connections of electrical and refrigerant circuit lines. It may be installed on a floor or flat roof or wall-mounted, provided its weight is properly supported and there is no transmission of vibration to the adjacent rooms.

5.1.2.1 Before installing the outdoor unit, you should:

- a) If an awning is built over the unit to prevent direct sunlight or rain, be careful that heat radiation from the condenser is not obstructed.

- b).Select a place that is easy to connect indoor unit's pipe and electric wires.
- c).Avoid a place where combustible gas may leak or stay.
- d).Keep it in mind that water may drain out of the outdoor unit while in "Heat" mode.
- e).Ensure the space around the back and sides and the front of the unit.
- f).Take the air conditioner weight into account and select a place where noise and vibration are minimum.

5.1.2.2 If the outdoor unit is to be installed on a roof or where no constructions are around, you should avoid hard wind blows directly to the air outlet, because it may cause trouble for air-flow shortage.

For example:

Let the air outlet face a wall (if there is one) with a distance about 300 centimeters between them.

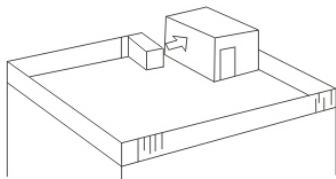

Try to make the air outlet vertical to wind direction if it is known in the season you use the system.

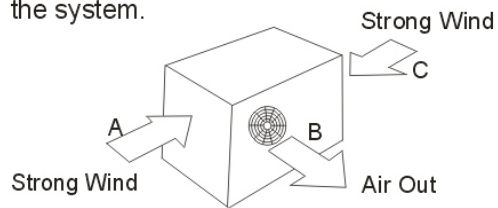

In directions (A), (B), (C), leave open two of the three directions.

5.1.2.3 Reserve enough space for installation, maintenance and unit-functioning.

Remove as many obstacles as possible nearby.

When the air-in surface is facing a wall

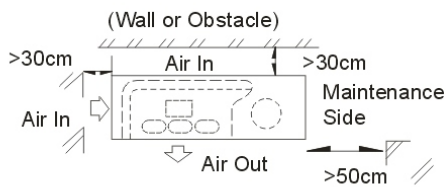

When the air-out surface is facing a wall

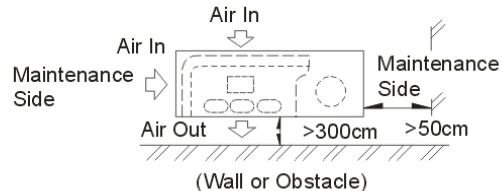

Caution:

Installation in the following places may cause trouble. If it is unavoidable to use in such places, please consult with the dealer.

- (1) A place full of machine oil.
- (2) A saline place such as coast.
- (3) Hot-spring resort.
- (4) A place full of sulfide gas.
- (5) A place where there are high frequency machines such as wireless installation, welding machine, medical facility.
- (6) A place of special environmental conditions.

5.2 Installing

5.2.1 Indoor Unit:

1. Anti-falling;

To prevent the indoor unit from falling, you must:

- Pay full attention to the unit because its long outer shape makes it easy to fall;
- Firmly fix the unit to the wall or in the ground to avoid accidental falling.

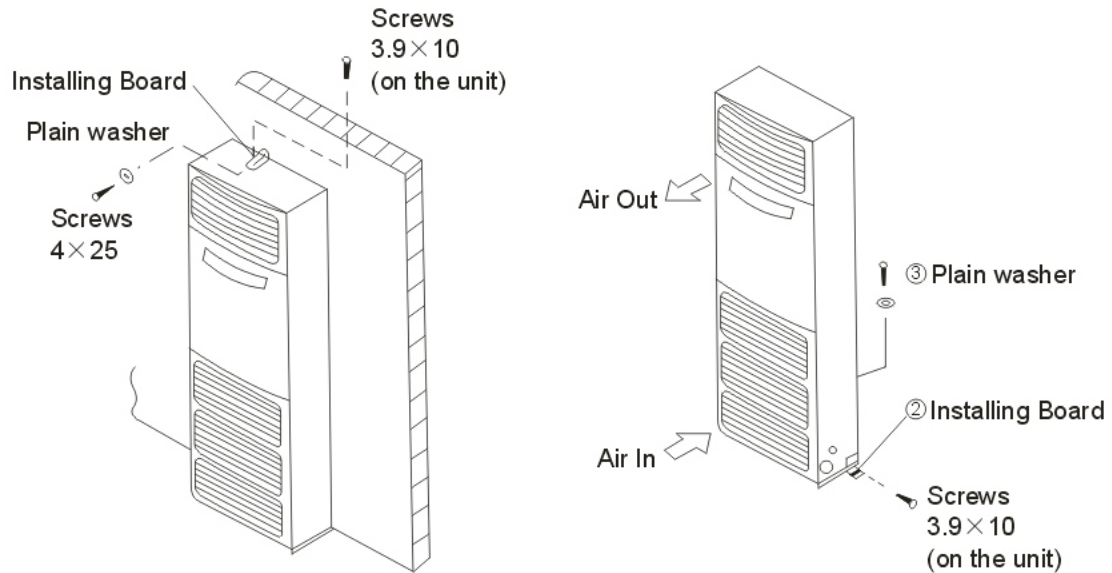

2. Dismounting the air-inlet grid

Please take off the air-inlet grid before connecting the pipes/wires.

Pull down the two knobs marked "PULL" on the grid, take off the two straps, then the air-inlet grid goes free.

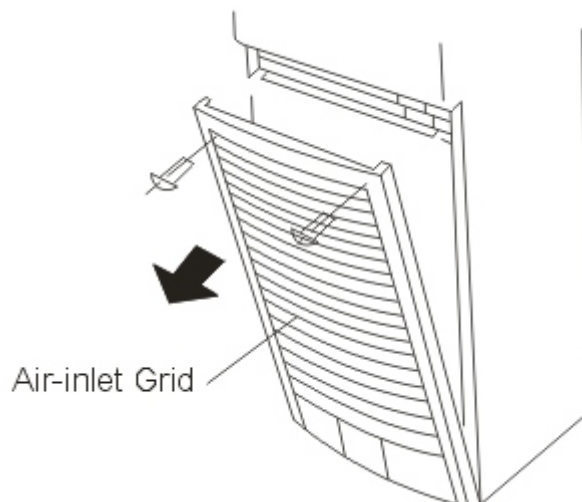

3. Take the Pipe Clip off before connecting the pipes and wiring; fit it when these finished.

Use accessories to connect the pipes/wires on both sides and back side.

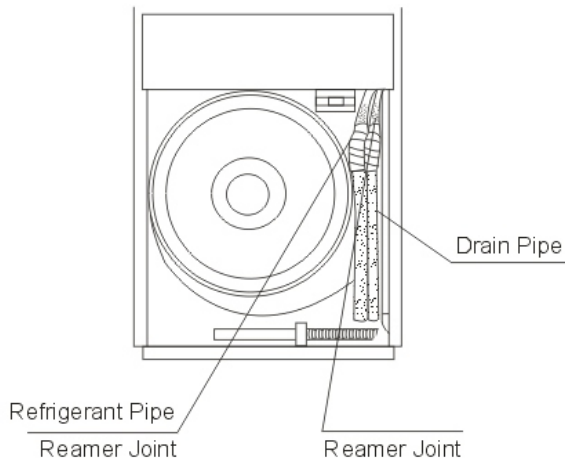

Pipe/wire-hole positions on both sides

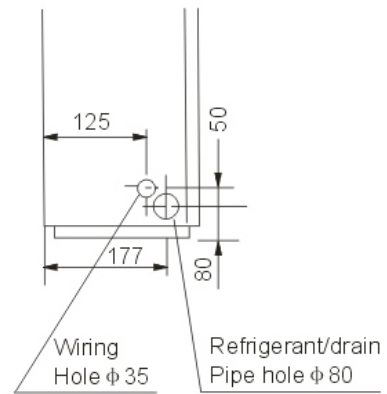

Pipe/wire-hole position on back side

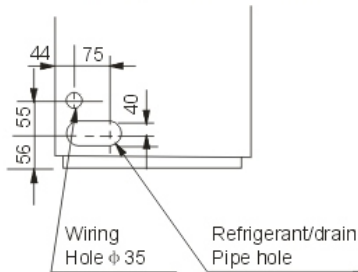

Pipe/wire-hole position on the bottom

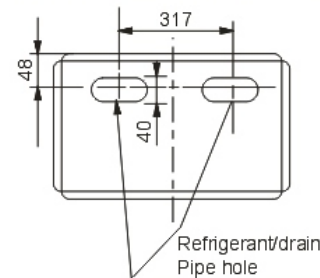

5.2.2 Outdoor Unit:

1. Ship the a/c to the installation place originally packed;
2. Be careful while hanging the unit because the center of gravity of the unit is not centralized;
3. Do not make the angle of inclination more than 45 degrees while shipping;(Avoid horizontal storage)
4. Be sure the electric insulation work is well done if installed on metal ceiling / wall.

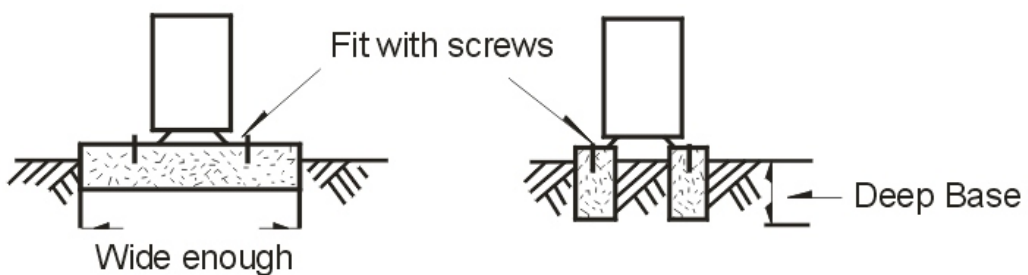

5. Fix the unit feet with bolts (M10). Be sure the unit is fixed strongly enough to against blast or earthquake.
6. Make a concrete basement to the unit by the above references.

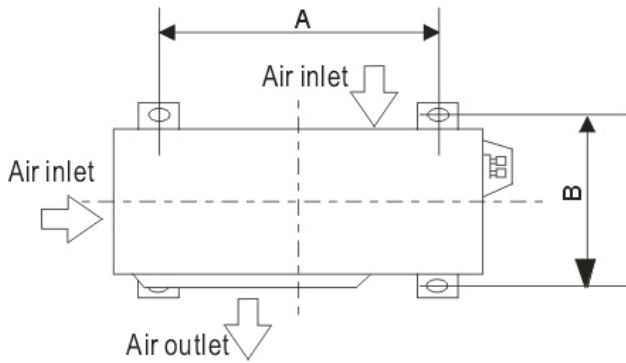

Dimension	A	B
Mode	(mm)	(mm)
55K	602	380

5.3 Refrigerant pipe connection

5.3.1 Pipe length and the elevation

The correct refrigerant quantity filled in the 5-meter-long pipe of the outdoor unit is marked on the Product Data Plate. If you have to use longer pipe for every meter plus pipe, the refrigerant should be added according to the following calculation.

Capacity Btu/h	Pipe size		Standard length (m)	Max. Elevation B (m)	Max. Length A (m)	Additional refrigerant (g/m)
	Gas	Liquid				
60K	3/4" (Φ19)	1/2" (Φ12.7)	5	15	30	60

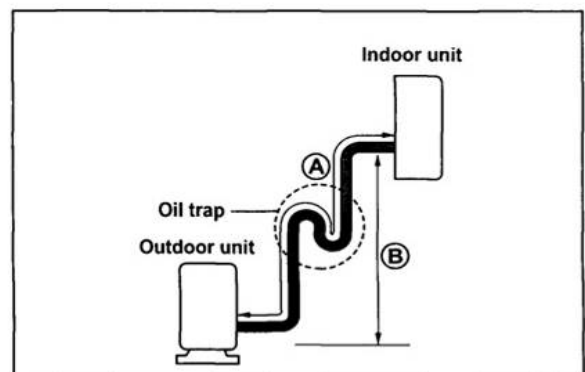
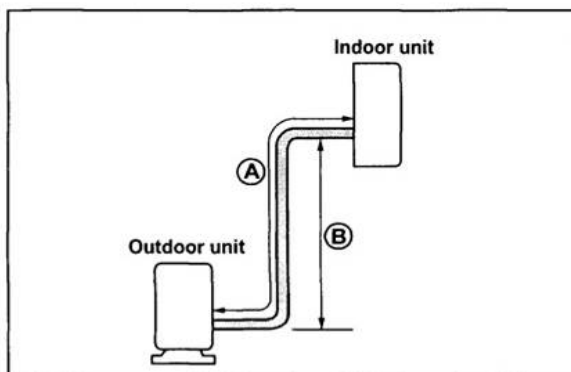

Caution:

Capacity is base on standard length and maximum allowance length is base of reliability.

Oil trap should be installed per 5-7 meters.

5.3.2 Piping connection**5.3.2.1 Connecting Of Refrigerant Pipe**

- a) Only the correctly installing of indoor and outdoor unit done, can the refrigerant pipe be connected.
- b) The cut-off valves are completely close before ex-work. Before connecting the refrigerant pipe, be careful to check whether the valves are completely close.
- c) The connecting procedure of refrigerant pipe: first, unscrew the two valves on the outdoor unit and the pipe-jointing nut on the indoor unit(please keep them care fully). Please connect the refrigerant pipe according to the manual, the pipe-jointing nut should be screw tightly and no leakage. Note: you need two wrenches to make balance.
- d) When the connecting of refrigerant pipe is finished, before power on the system, you should vacuum the indoor unit through the maintenance port on the cut-off valves, or open the high-pressure valve, and exhaust the air through the maintenance port on the low-pressure valve(closed). It will take about ten seconds. Then screw tightly the maintenance port. (When supplement the refrigerant, fill through the maintenance port of the low-pressure valves on the outdoor unit).
- e) Open all the valves completely before power on the system, or it will be sick for low efficiency.
- f) Gas leak check. Make sure no gas from connections with leak detector or soap water.

5.3.2.2 Pipe Connecting Procedures

Completely shut the cut-off valves of the outdoor unit (as ex-work status). Unscrew the nuts on the cut-off valves and immediately connect the reamer joint (in 5 minutes). If it last too long, dust,vapor and other obstacles may enter the pipe and cause trouble later on. Before connecting the pipe, the air in the pipe should be removed in advance by releasing refrigerant R-410A.

Notes for the bendable pipe

- a. The bendable pipe should be used on the indoor side;
- b. Bend angle may not exceed 90 degrees;
- c. The bend location should be made on the center of the pipe if possible, as for bend radius, the bigger the better;
- d. The bendable pipe may not be bent for more than 3 times.

Bend the thin pipe

- a. While bending, expose the pipe by cutting the concave gap on the bending heat-insulation pipe (roll it with soft band after bent).
- b. To avoid pipe deformation, the radius is the bigger the better.
- c. Use a pipe-bending device to make the compact bending pipe.

Use thumb to curve the pipe



Min. Radius 100 mm

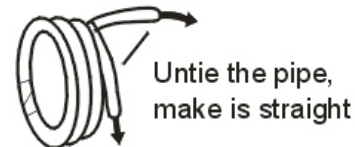

5.3.2.3 Using bronze pipe selling in market

Completely shut the cut-off valves of the outdoor unit (as ex-work status). After the refrigerant pipe has been connected with both the indoor and outdoor unit, let the air exhaust out from the maintenance gap on the low-pressure cut-off valves of the outdoor unit. Screw the nuts tightly on the maintenance gap after the air has been drained.

5.3.2.4 To make the refrigerant pipe unblocked completely

You should keep the cut-off valves of the outdoor unit completely open after you have finished the above steps (5.3.2.2 or 5.3.2.3)

Note:

1. Before screwing the reamer nut, smear the pipe and the connecting surface with refrigerant oil;
2. Check and make sure there is no leakage by soap-water or leakage-checker after connecting;
3. Be sure the connecting joint on the indoor side is insulated.
4. Use two wrenches to connecting the pipes.

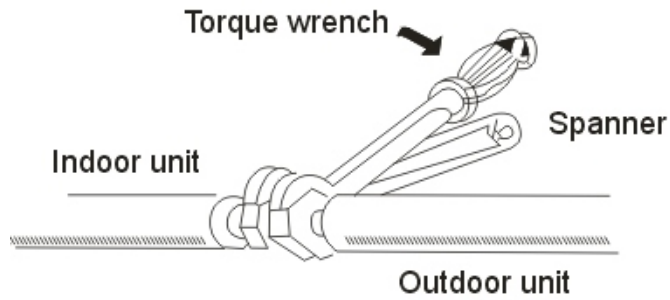

Outside diameter		Torque	Additional tightening torque
mm	inch	N.cm	N.cm
Φ12.7	1/2	4950	6030
Φ19	3/4	9720	11860

5.3.3 Air purging with vacuum pump

Air and moisture in the refrigerant system have undesirable effects as below:

- Pressure in the system rises.
- Operating current rises.
- Cooling or heating efficiency drops.
- Moisture in the refrigerant circuit may freeze and block capillary tubing.
- Water may lead to corrosion of parts in the refrigerant system.

Therefore, the indoor units and the pipes between indoor and outdoor units must be leak tested and evacuated to remove gas and moisture from the system.

Air purging with vacuum pump

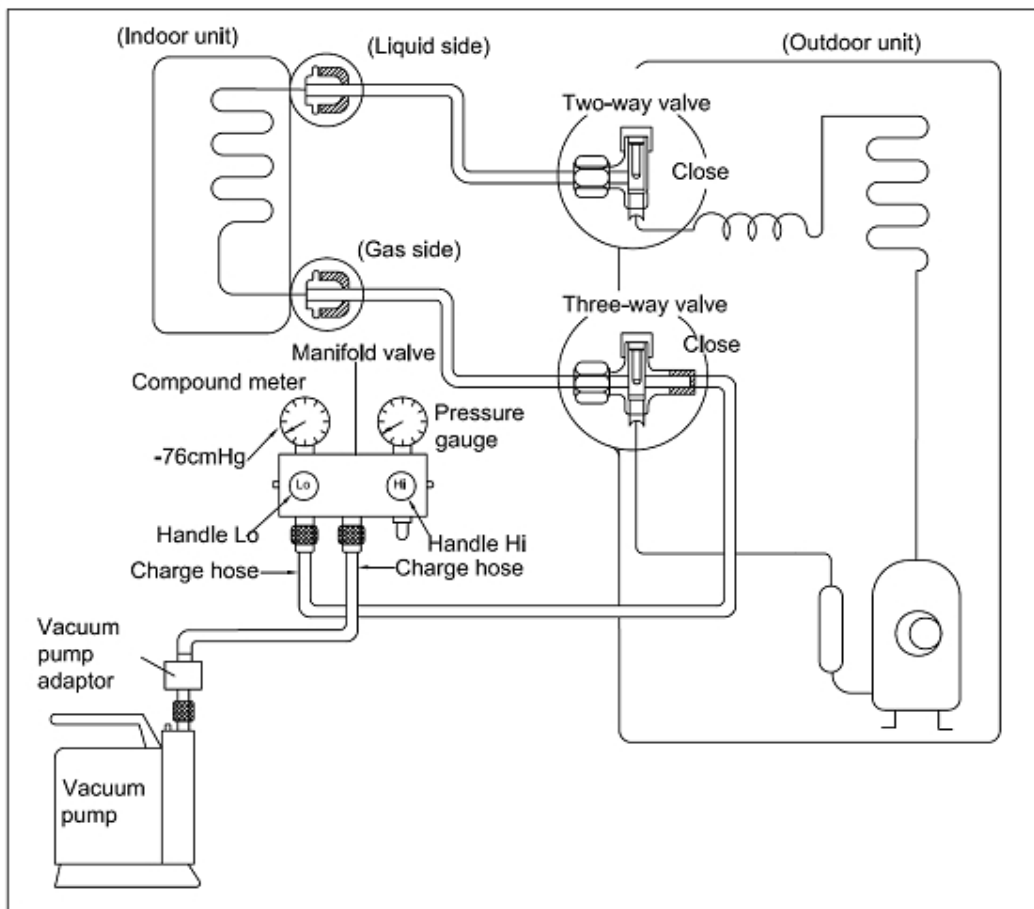

1. Completely tighten the flare nuts of the indoor and outdoor units, connect the manifold valve charge.
2. Connect the charge hose connection to the vacuum pump.
3. Fully open the handle Lo of the manifold valve.
4. Operate the vacuum pump to evacuate. After starting evacuation, slightly loose the flare nut of the Lo valve on the gas pipe side and check the air is entering. (Operation noise of the vacuum pump changes and a compound meter indicates 0 stead of minutes)
5. After the evacuation is complete, fully close the handle Lo valve of the manifold valve and stop the operation of the vacuum pump. Make evacuation for 15 minutes or more and check the compound meter indicates -76cmHg ($-1 \times 10^5 \text{Pa}$).
6. Turn the stem of the Hi valve about 45° counterclockwise for 6 or 7 seconds after the gas coming out, then tighten the flare nut again. Make sure the pressure display in the pressure indicator is a little higher than the atmosphere pressure.
7. Remove the charge hose from the Lo pressure charge hose.

8. Fully open the Hi and Lo packed valve.
9. Securely tighten the cap of the packed valve.

Gas leak check

Soap water method

Apply soap water or a liquid neutral detergent on the indoor unit connections or outdoor unit connections by a soft brush to check for leakage of the connecting points of the piping. If bubbles come out, the pipes have leakage.

5.3.4 Pumping down (Re-installation)

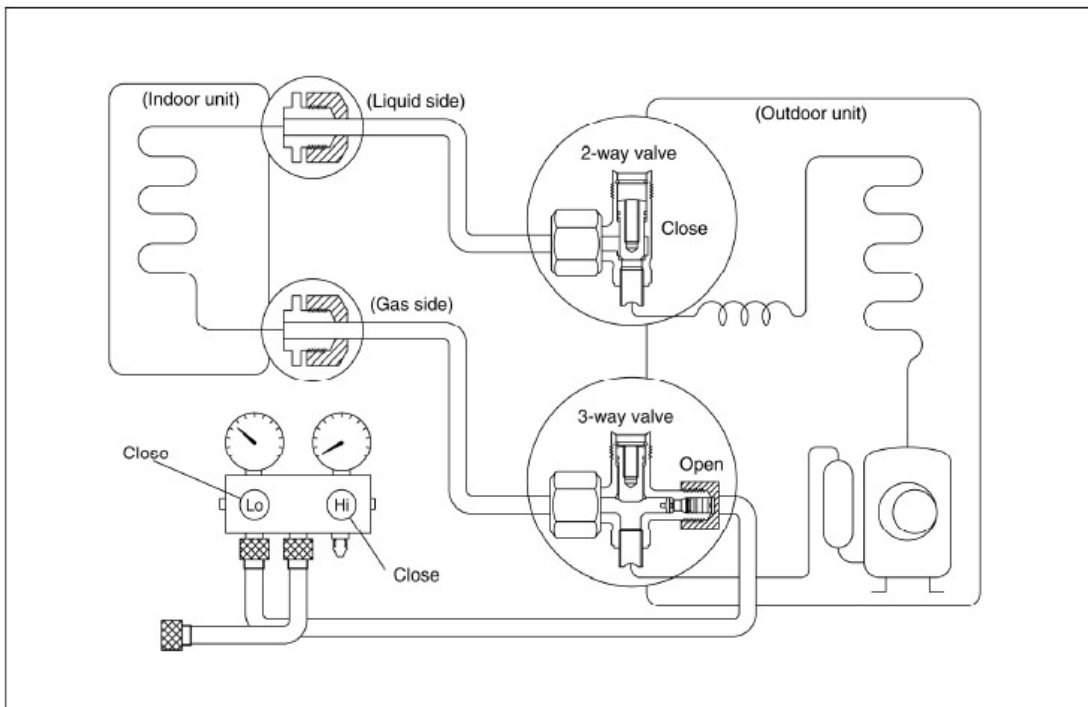

Procedure

1. Confirm that both the 2-way and 3-way valves are set to the opened position.
Remove the valve stem caps and confirm that the valve stems are in the opened position.
Be sure to use a hexagonal wrench to operate the valve stems.
2. Operate the unit for 10 to 15 minutes.
3. Stop operation and wait for 3 minutes, then connect the charge set to the service port of the 3-way valve.

Connect the charge hose with the push pin to the gas service port.

5. Air purging of the charge hose.

Open the low-pressure valve on the charge set slightly to purge air from the charge hose.

6. Set the 2-way valve to the close position.

7. Operate the air conditioner at the cooling cycle and stop it when the gauge indicates 0.1MPa.

8. Immediately set the 3-way valve to the closed position.

Do this quickly so that the gauge ends up indicating 0.3 to 0.5Mpa.

Disconnect the charge set, and amount the 2-way and 3-way valve's stem nuts and service port caps.

Use a torque wrench to tighten the service port cap to a torque of 1.8 kgf.m.

Be sure to check for gas leakage.

5.3.5 Re-air purging (Re-installation)

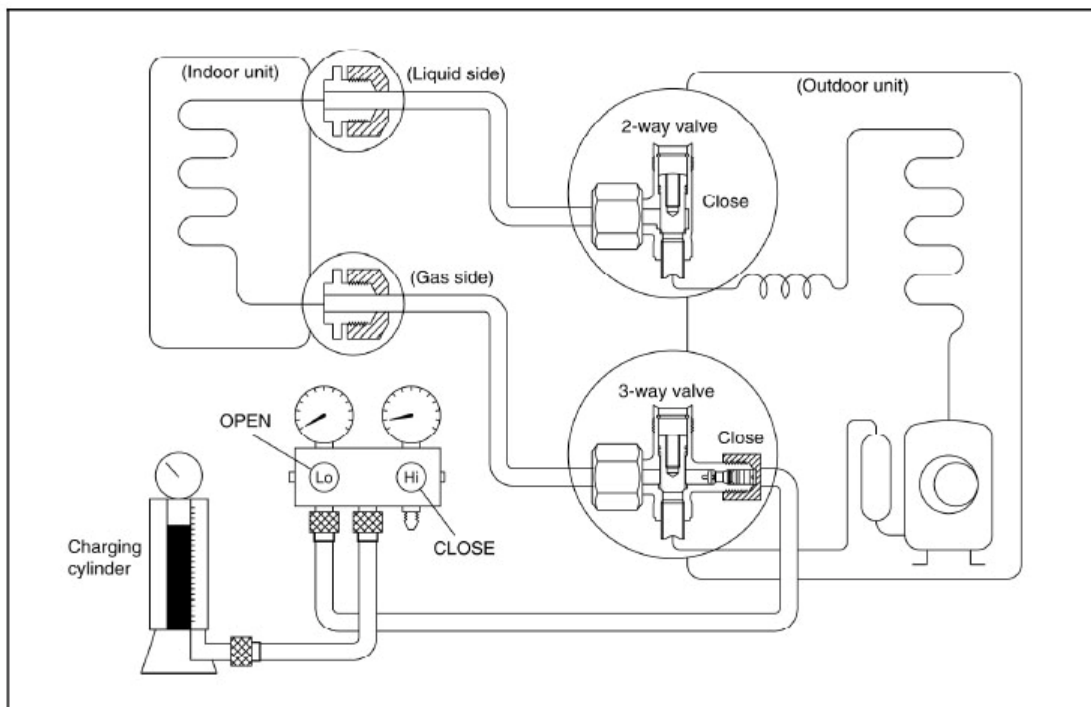

Procedure:

1. Confirm that both the 2-way and 3-way valves are set to the closed position.

2. Connect the charge set and a charging cylinder to the service port of the 3-way valve.

Leave the valve on the charging cylinder closed.

3. Air purging.

Open the valves on the charging cylinder and the charge set. Purge the air by loosening the flare nut on the 2-way valve approximately 45° for 3 seconds then closing it for 1 minute; repeat 3 times.

After purging the air, use a torque wrench to tighten the flare nut to on the 2-way valve.

4. Check the gas leakage.

Check the flare connections for gas leakage.

5. Discharge the refrigerant.

Close the valve on the charging cylinder and discharge the refrigerant until the gauge indicates 0.3 to 0.5 Mpa.

6. Disconnect the charge set and the charging cylinder, and set the 2-way and 3-way valves to the open position.

Be sure to use a hexagonal wrench to operate the valve stems.

7. Mount the valve stems nuts and the service port cap.

Be sure to use a torque wrench to tighten the service port cap to a torque 18N.m.

Be sure to check the gas leakage.

5.3.6 Balance refrigerant of the 2-way, 3-way valves

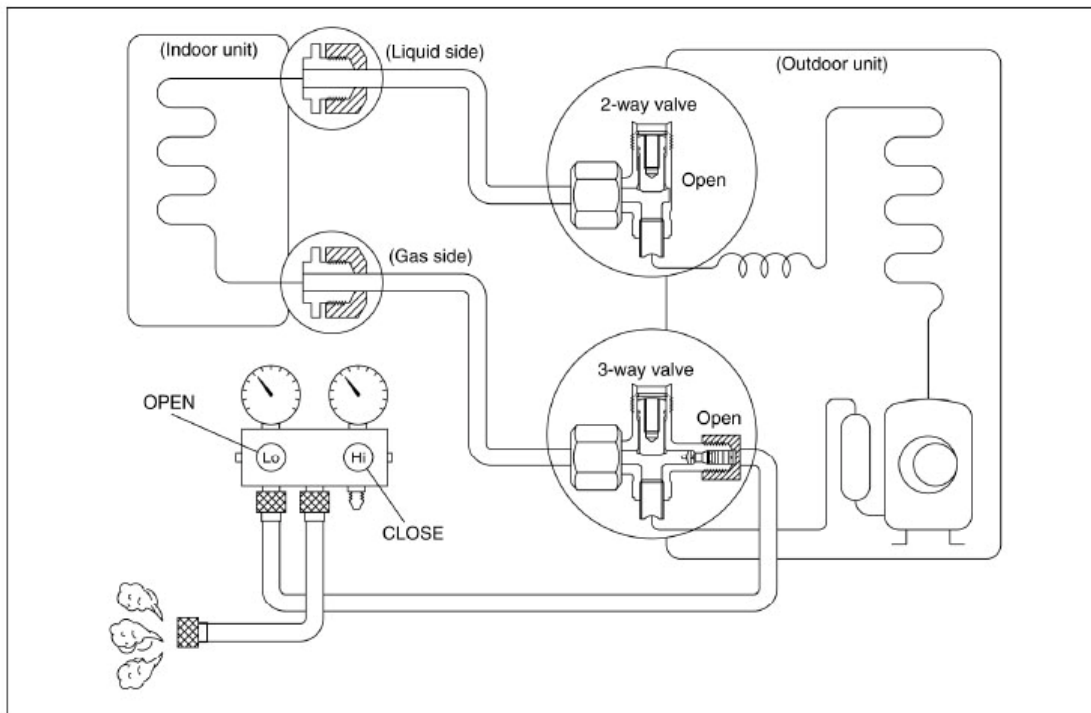

Procedure:

1. Confirm that both the 2-way and 3-way valves are set to the open position.
2. Connect the charge set to the 3-way valve's service port.

Leave the valve on the charge set closed.

Connect the charge hose with the push pin to the service port.

3. Open the valves (Low side) on the charge set and discharge the refrigerant until the gauge indicates 0.05 to 0.1Mpa.

If there is no air in the refrigeration cycle [the pressure when the air conditioner is not running is higher than 0.1Mpa, discharge the refrigerant until the gauge indicates 0.05 to 0.1 Mpa. If this is the case, it will not be necessary to apply an evacuation.

Discharge the refrigeration gradually; if it is discharged too suddenly, the refrigeration oil will be discharged.

5.3.7 Evacuation

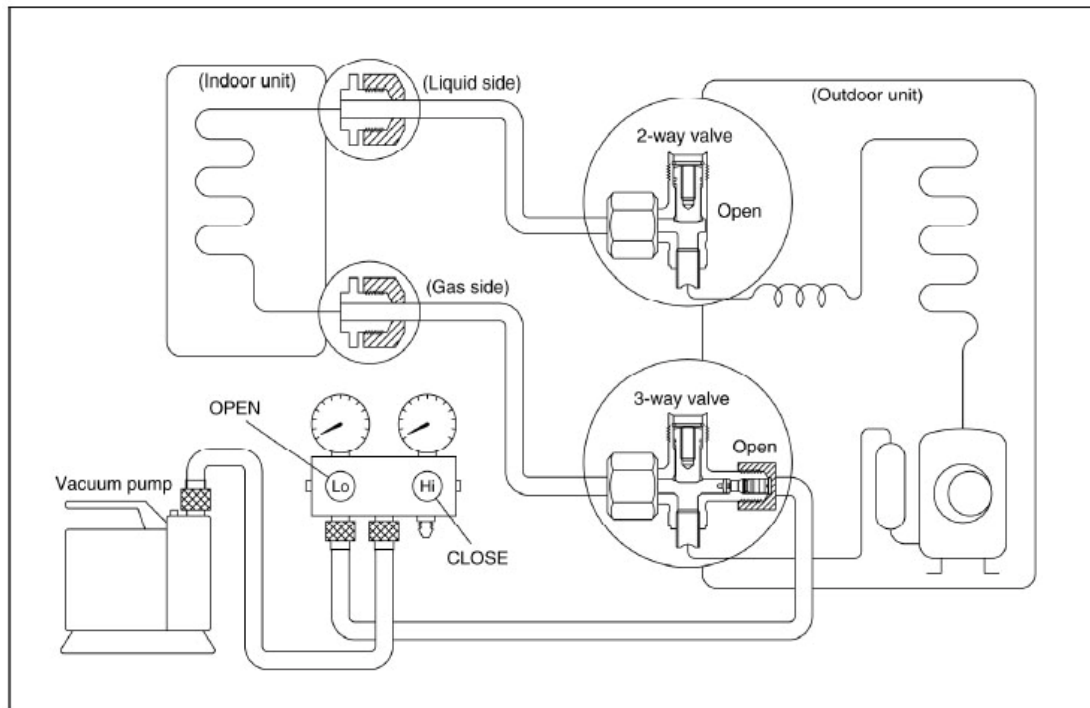

Procedure:

1. Connect the vacuum pump to the charge set's centre hose.
2. Evacuation for approximately one hour.

Confirm that the gauge needle has moved toward -0.1 Mpa (-76 cmHg) [vacuum of 4 mmHg or less].

3. Close the valve (Low side) on the charge set, turn off the vacuum pump, and confirm that the gauge needle does not move (approximately 5 minutes after turning off the vacuum pump).

4. Disconnect the charge hose from the vacuum pump.

Vacuum pump oil, if the vacuum pump oil becomes dirty or depleted, replenish as needed.

5.3.8 Gas charging

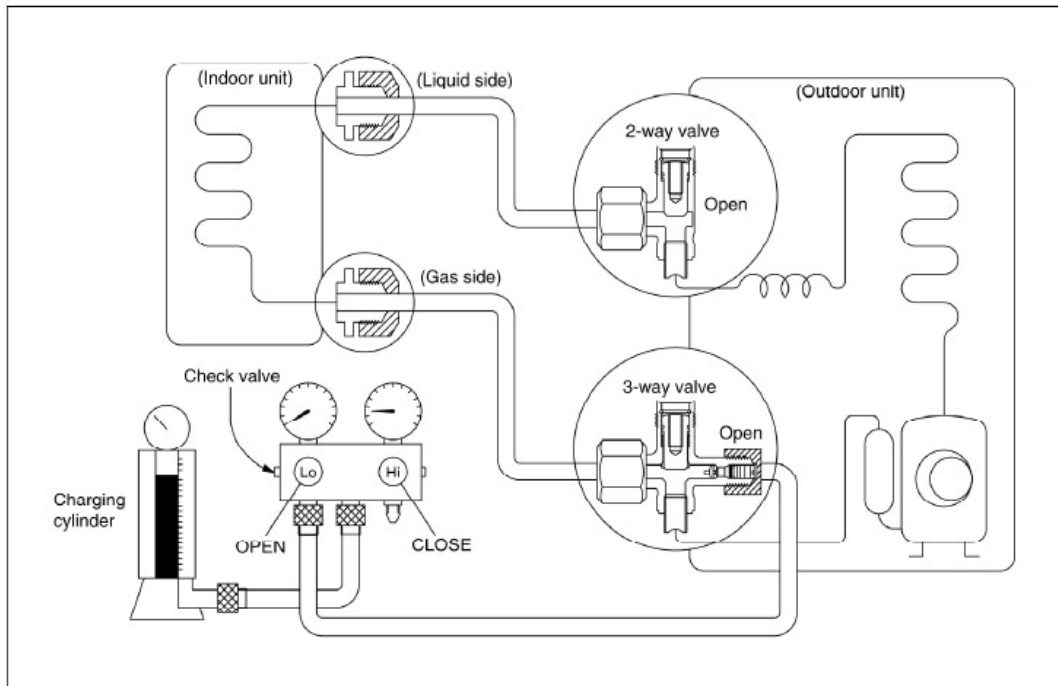

Procedure:

1. Connect the charge hose to the charging cylinder.

Connect the charge hose which you disconnected from the vacuum pump to the valve at the bottom of the cylinder. If the refrigerant is R410A, make the cylinder bottom up to ensure liquid charge.

2. Purge the air from the charge hose.

Open the valve at the bottom of the cylinder and press the check valve on the charge set to purge the air (be careful of the liquid refrigerant).

3. Open the valves (Low side) on the charge set and charge the system with liquid refrigerant.

If the system cannot be charge with the specified amount of refrigerant, it can be charged with a little at a time (approximately 150g each time) while operating the air conditioner in the cooling cycle; however, one time is not sufficient, wait approximately 1 minute and then repeat the procedure.(pumping down-pin).

4. Immediately disconnect the charge hose from the 3-way valve's service port.

Stopping partway will allow the refrigerant to be discharged.

If the system has been charged with liquid refrigerant while operating the air conditioner, turn off the air conditioner before disconnecting the hose.

5. Mounted the valve stem caps and the service port

Use torque wrench to tighten the service port cap to a torque of 18N.m.

Be sure to check for gas leakage.

5.4 Drain Pipe of The Indoor Unit

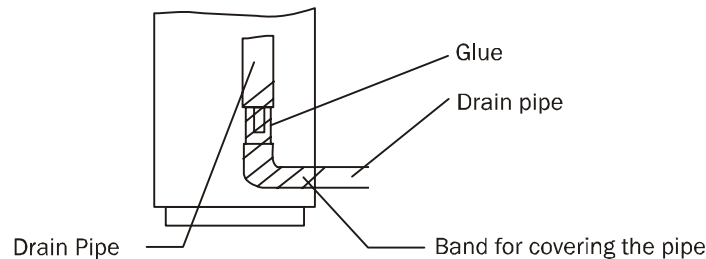

1. Make sure the drain pipe is connected to the outdoor side downward;
2. The hard polyvinyl chloride (PVC) plastic pipe (external diameter 26 mm) sold in the market is suitable for the attached soft drain pipe;
3. Please connect the Soft Drain Pipe with the Drain Pipe, then fix it with band;
4. If you have to connect the Drain Pipe indoors, to avoid condensing caused by air intake, you must cover the pipe with heat-insulation material (polyethylene with Specific Gravity of 0.03, at least 9 mm in thickness), and use Glue Band to fix it.
5. After the Drain Pipe has been connected, please check if the water drains out of the pipe efficiently and has no leakage.
6. Refrigerant pipe and Drainpipe should be heat-insulated to avoid condensing and water-dropping later on.

5.5 Wiring

Please refer to the Wiring Diagram.

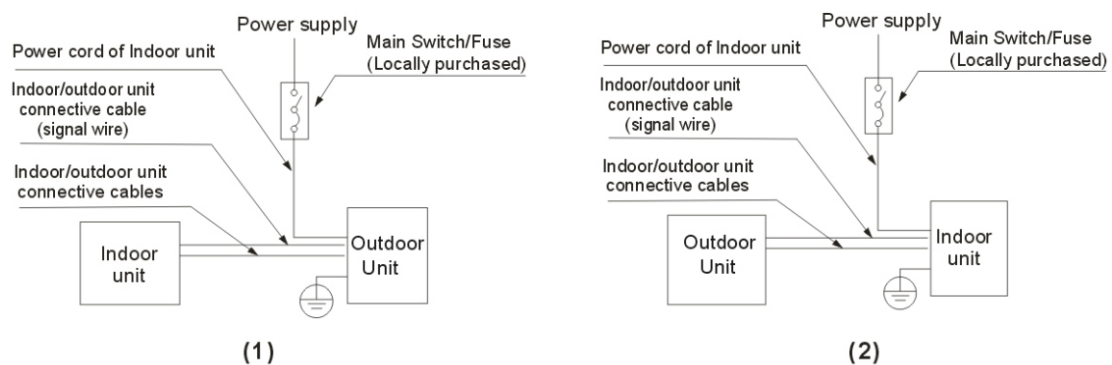

Note: The power supply of the air conditioner is different according to the models. Please refer to the WIRING DIAGRAM pasted on the indoor and outdoor units before wire connection.

5.6 TEST RUN

1. Make sure the resistance between the socket of the electric system and the grounded line, when detected by a 500 V million-ohmmeter, is at least 2 million ohms. If the resistance is less than the number, please do not use the air conditioner;
2. Check again if the air conditioner is properly installed, especially for the anti-falling device;
3. When accomplished all the above procedures, service people should explain and test the air conditioner for the customer according to the "User's Manual".

6. External view and display

6.1 PARTS NAMES

This unit consists of indoor unit and outdoor unit.

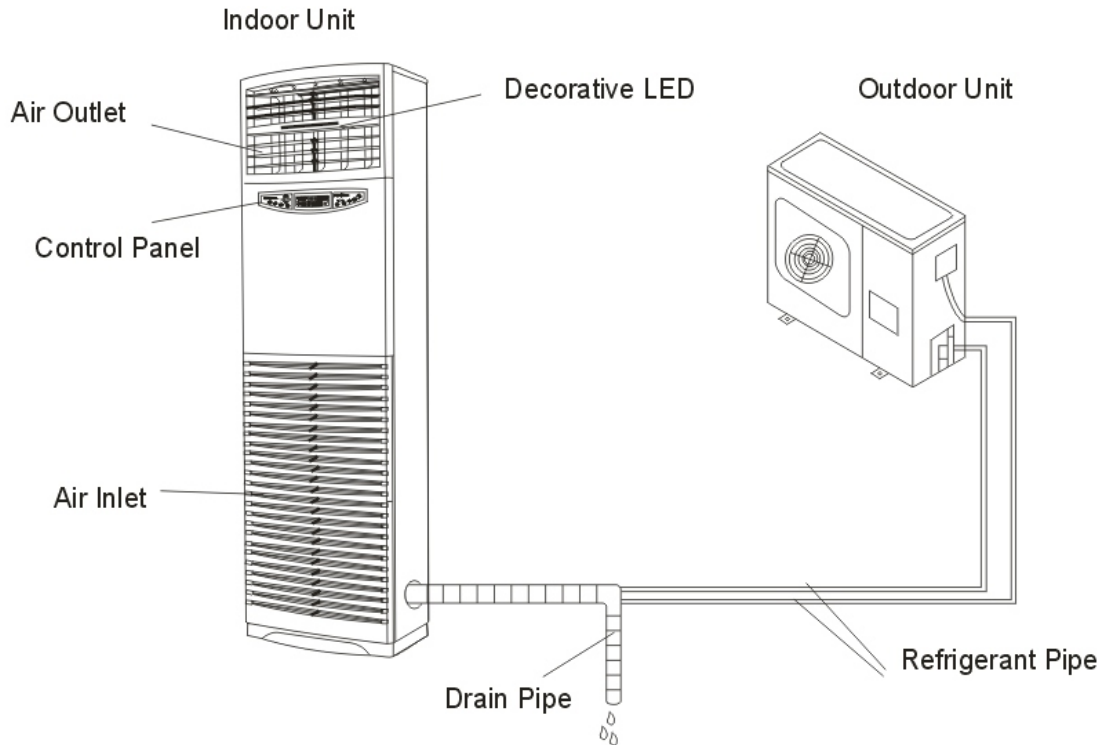

Note:

All the pictures in this manual are for explanation purpose only. They may be slightly different from the air conditioner you purchased (depend on model). The actual shape shall prevail.

Air Outlet	Let the conditioned air go out from it.
Control Panel (inserted)	Consists of indicators and control buttons.
Air Inlet	Where a filter is settled, absorbing the air in the room and clean it.
Drain Pipe	From which the condensed water is drained.
Refrigerant Pipe	In which the refrigerant passes through, connects the outdoor unit with the indoor unit.
Outdoor (condensing) Unit	Consists of compressor, fan motor, heat-exchanger and other electric parts.
Decorative LED	Displays green or red lights according to running mode.

6.2 CONTROL PANEL

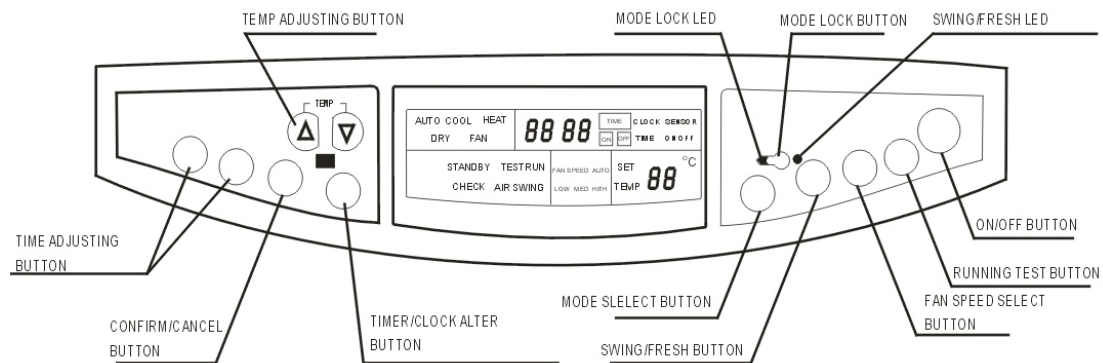

On/Off button: Power-on and power-off the A/C(Air conditioner)

LED indicator :Lights when unit runs normally ,flashes one time per second when the unit is waiting for orders ,flashes two times per second when the unit is sick.

Mode select button : Use this button to select among the following 5 modes :

Auto :automatically adjust the temperature (17~30°C)

Cool :normal cooling operation(17~30 °C)

Heat :(for cooling and heating only)normal heating operation(17~30°C)

Dry :dehumidify the room air and keep the indoor temperature(17~30°C)

Fan :fan only ,no cooling

Temp .adjusting buttons :

warm ▲ :push this button to raise the setting temperature

cool ▼ :push this button to lower the setting temperature.

Fan Speed button :

Auto :automatically adjust the fan speed

Low :Low fan speed.

Med :Medium fan speed

High :High fan speed

Swing /fresh button :push this button to make the air-flow blow left or right and anion producer open.

Time/clock Alter button (Short form :ALT button):use this button to alter the modes between 'time' and 'clock'.

Time adjusting button:

‘Hour’: set the hour of current time

‘Minute’: set the minute of current time

Confirm/Cancel button :Push this button to confirm or cancel the timer setting

Test Running button :Push this button to make the unit run for an hour of test ,this function is specially designed for maintenance technicians.

6.3 LED

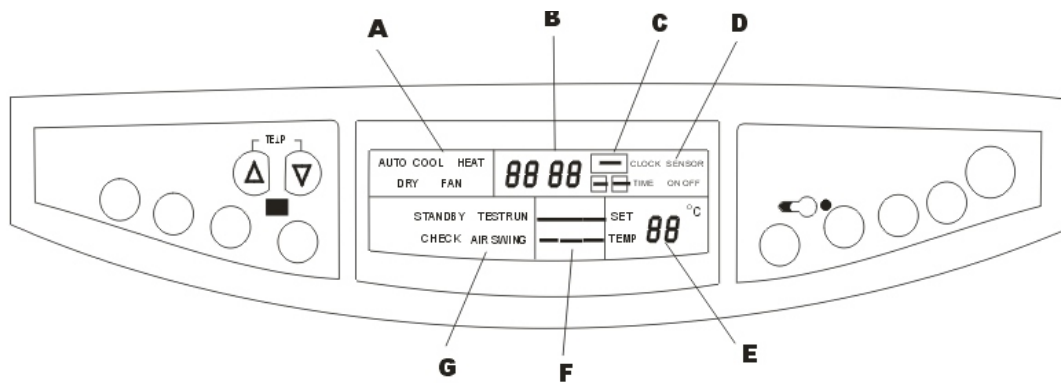

A. Operation modes

B. Timer setting clock or trouble display

C. Timer display

D. Types of clock

E. Room temperature setting display

F. Fan speed of the indoor unit display

G. Status display

7. Operation characteristics

Mode Temperature	Cooling operation	Heating operation	Drying operation
Room temperature	17°C~32°C	17°C~30°C	17°C~32°C
Outdoor temperature	18°C~43°C	-7°C~24°C	18°C~ 43°C

CAUTION:

1. If air conditioner is used outside of the above conditions, certain safety protection features may come into operation and cause the unit to function abnormally.

2. Room relative humidity less than 80%. If the air conditioner operates in excess of this figure, the surface of the air conditioner may attract condensation. Please sets the vertical air flow louver to its maximum angle (vertically to the floor), and set HIGH fan mode.

3. Optimum performance will be achieved within this operating temperature.

8. Electronic function

8.1 Main data Introduction

Ts : Set temperature,

T1 : Room temperature

T2: Evaporator pipe temperature

T3: Condenser pipe temperature

T4: Outdoor ambient temperature

8.2 Operation Modes and Functions

8.2.1 Manual Operation

8.2.2 Heating Mode

8.2.2.1 Four-way valve opens at once and anti-cold air function opens at the same time, electric heaters starts or stops according to 8.2.2.5.

8.2.2.2 Condition for the compressor and outdoor fan action: (Ts=set temperature, T1=room temperature)

Condition	Compressor and outdoor fan(High)
Ts-T1 \geq 1°C and compressor is off reaches up to over 4 minutes	On
T1-Ts>2°C	Off

8.2.2.3 Indoor Fan Action

Auto fan in heating mode

Condition	Fan speed
Ts-T1 \geq 4°C	High
2°C \leq Ts-T1 < 4°C	Med
Ts-T1 < 2°C	Low

8.2.2.4 Anti-cold air:

Switchover between fan speed and fine tune can be set according to temperature of evaporator pipe (T2).

	Condition	Fan speed
Room temperature up	T2<25°C	Off
	25°C <T2<32°C	Breeze
	T2>32°C	Set fan speed
Room temperature down	T2>30°C	Set fan speed
	30°C >T2>20°C	Breeze
	T2<20°C	Off

8.2.2.5 Electric heaters (only available to some modes)

Electric heaters only opens in heating mode

Condition	Electric heaters
Ts-T1 > 6°C and indoor fan opens,T2 < 50 °C	On
T1 \geq Ts or indoor fan closes or T2 > 52 °C	Off

8.2.3 Defrost (only available to heating mode)

8.2.3.1 Defrosting Conditions

Starting Of Defrosting Condition (meet one of the following is ok):

(1) Under evaporator high temperature protection, the accumulated time when outdoor fan motor is off and compressor is on reaches up to over 90 minutes. (IF compressor shuts down , calculate time again).

(2) Accumulated compressor operating time when temperature of outdoor heat exchanger coil T3 is below -2°C reaches up to over 40 minutes. (IF compressor shuts down , calculate time again).

8.2.3.2 Defrosting Action

Four-way valve, indoor fan, outdoor fan are shut down. Compressor keeps on.

8.2.3.3 Ending Of Defrosting Condition (meet one of the following is ok):

- (1) Time of defrosting lasts 10 minutes.
- (2) Temperature of outdoor coil T3 is up to 20°C.
- (3) High temperature protection opens (When compressor shuts down), defrosting will end, calculate time again.

8.2.4 Cooling Mode

8.2.4.1 Conditions for the compressor and outdoor fan action (T_s = set temperature)

Condition	Compressor and outdoor fan
$T_1 - T_s \geq 1^\circ\text{C}$ and compressor is off reaches up to over 3 minutes	On
$T_s - T_1 > 1^\circ\text{C}$	Off

8.2.4.2 Action of Indoor Fan

HIGH/ MED /LOW/AUTO fan can be switched over by your comfort.

Auto fan under cooling mode.

Condition	Fan speed
$T_1 - T_s \geq 4^\circ\text{C}$	High
$2^\circ\text{C} \leq T_1 - T_s < 4^\circ\text{C}$	Med
$T_1 - T_s < 2^\circ\text{C}$	Low

8.2.5 Dehumidifying Mode

8.2.5.1 Indoor fan speed is low.

8.2.6 Auto Mode

8.2.6.1. Under auto mode, the indoor fan is set to be auto.

8.2.6.2 When entering auto mode, the heating, fan only or cooling operation will be automatically chosen according to the room temperature T_1 and the set temperature T_s .

Condition	Mode
$3^\circ\text{C} \leq T_1 - T_s$	Cooling
$-3^\circ\text{C} \leq T_1 - T_s \leq 3^\circ\text{C}$	Fan
$T_1 - T_s < -3^\circ\text{C}$	Heating (fan for cooling only type)

8.2.6.3. After one mode is chosen, the operation mode will be re-chosen according to the T_1 and T_s .

Condition	Mode
$3^\circ\text{C} \leq T_1 - T_s$	Cooling
$-3^\circ\text{C} \leq T_1 - T_s \leq 3^\circ\text{C}$	Former mode
$T_1 - T_s < -3^\circ\text{C}$	Heating (fan for cooling only type)

8.2.7 Fan Only Mode

8.2.7.1 Under this mode, four-way valve, compressor and outdoor fan are shut down, indoor fan keeps on.

8.2.7.2 High/Med/Low/Auto fan can be switched over through manual control.

8.2.7.3 Under auto mode, the indoor fan is set to be Med.

8.3 Other Functions

8.3.1 LCD display

Mode, Set temp., fan speed, time, timer, etc.

8.3.2 Timer

The machine should be provided with max. Interval of 24h.

9. Characteristic of temperature sensor

Temp. °C	Resistance KΩ	Temp. °C	Resistance KΩ	Temp. °C	Resistance KΩ
-10	62.2756	17	14.6181	44	4.3874
-9	58.7079	18	13.918	45	4.2126
-8	56.3694	19	13.2631	46	4.0459
-7	52.2438	20	12.6431	47	3.8867
-6	49.3161	21	12.0561	48	3.7348
-5	46.5725	22	11.5	49	3.5896
-4	44	23	10.9731	50	3.451
-3	41.5878	24	10.4736	51	3.3185
-2	39.8239	25	10	52	3.1918
-1	37.1988	26	9.5507	53	3.0707
0	35.2024	27	9.1245	54	2.959
1	33.3269	28	8.7198	55	2.8442
2	31.5635	29	8.3357	56	2.7382
3	29.9058	30	7.9708	57	2.6368
4	28.3459	31	7.6241	58	2.5397
5	26.8778	32	7.2946	59	2.4468
6	25.4954	33	6.9814	60	2.3577
7	24.1932	34	6.6835	61	2.2725
8	22.5662	35	6.4002	62	2.1907
9	21.8094	36	6.1306	63	2.1124
10	20.7184	37	5.8736	64	2.0373
11	19.6891	38	5.6296	65	1.9653
12	18.7177	39	5.3969	66	1.8963
13	17.8005	40	5.1752	67	1.83
14	16.9341	41	4.9639	68	1.7665
15	16.1156	42	4.7625	69	1.7055
16	15.3418	43	4.5705	70	1.6469

10. Trouble shooting

10.1 Protective Function

10.1.1 3-minute delay for the compressor start-up

At the beginning of energizing the compressor starts at once, after the stop of the compressor in any modes, 3-minute(cooling) or 4-minute(heating) delay will be needed to start the compressor.

When switching over between cooling/heating mode, the compressor stops automatically While Defrosting the compressor keeps on.

10.1.2 Evaporator protection against high temperature

10.1.2.1 Only avail able under heating mode.

10.1.2.2 The operation principle is as follows: (T2 = evaporator temperature)

	Condition	Outdoor fan	Compressor
Room temperature up	T2>56°C	Off	On
	T2>60°C	Off	Off
Room temperature down	T2>54°C	Off	Off
	T2<54°C	On	On

10.1.2.3 The restart of the compressor shall execute the delay protection.

10.1.3 Evaporator Protection against low temperature

10.1.3.1 Only available under cooling and dehumidifying status.

10.1.3.2 Protection principle:

	Condition	Outdoor fan	Compressor
Room temperature down	T2≤-1°C	Off	Off
Room temperature up	T2≥10°C	On	On

10.1.3.3 The restart of the compressor shall execute the delay protection.

10.1.4 Condenser high temperature protection

10.1.4.1 Only available to cooling and dehumidifying mode.

10.1.4.2 Action condition

	Condition	Compressor
Room temperature up	Condenser temp.≥65°C	Off
Room temperature down	Condenser temp.<60°C	On

10.1.5 Outdoor protection

When outdoor protection signal is high level, outdoor unit will perform protection: the whole machine will be shut down while the indoor unit will indicate the corresponding protection signal.

The A/C will recover if outdoor protection signal is low level.

10.1.6 Air outlet of indoor unit high temperature protection

When the temperature of air outlet of indoor unit is up to 70°C, protection signal is high level, then the unit will perform protection : electric heaters will be shut down at once, indoor fan speed will be high and four-way valve, compressor and outdoor fan are shut down.

The A/C will recover if the temperature of air outlet of indoor unit is down to 55°C.

10.2 Self-diagnosis

Codes	Contents
E01	The temp. sensor is off, or short-circuit.
E02	Compressor is over current
E04	Outdoor unit protection
P02	Compressor is over load
P03	The temperature of evaporator coil of indoor unit is too low (when cooling)
P04	The temperature of evaporator coil is too high (when heating)
P05	The temperature of air outlet of indoor unit is too high (when heating)

10.3 LEDs for the indication of outdoor trouble

In normal operation, LEDs emit no light and they will flash at a frequency of 2Hz when trouble occurs. Their codes are listed in the following table:

Type	Contents	LED1	LED2	LED3	Indication
Trouble	Phase sequence or Lack of phase(A ,B)	Flash	Off	Off	E04
Trouble	Lack of phase(C)	Off	Off	Off	E04
Trouble	Protection of low pressure	Flash	Flash	Off	E04
Trouble	Overload of current	Off	Off	Flash	E04
Trouble	Communication failure	Flash	Off	Flash	E04
Trouble	Open-circuit or short-circuit trouble of T3	Off	Flash	Flash	E04
Trouble	Open-circuit or short-circuit trouble of T4	Off	Flash	Off	E04
Trouble	Condenser high temperature protection	Flash	Flash	Flash	E04

Note: When the machine stands by ,LED1- LED3 flashes in low speed.

10.4 Troubles and Solutions

Before calling for service, please review the following list of common problems and solutions.

Problem	Possible Cause	Solutions
Unit Idleness	No electric power supply	Wait for power recovery
	Power Switch turned off	Turn on the switch
	Fuse blew	Replace the fuse
Air flow but poor cooling (heating)	Improper temperature setting	Readjust the temp. to a lower degree. See 'OPERATIONS' for details
	The air -filter blocked	Clean the air- filter
	Air inlet/outlet blocked	Clear the air inlet/outlet
	Windows/door are open	Close windows/door
Air flow but no cooling (heating)	The air inlet/outlet of indoor/outdoor unit are blocked up by something	Remove the obstacles which blocks the air inlet/outlet
	Too much dust or dirt on the air-filter	Clean the air-filter

The display board may show some types of the unit' s failures when it happened.

Number	Display code	Problems	What to do
1	E01	The temp. sensor is off, or short-circuit.	Contact service people
2	E02	Compressor is over current	Turn off the unit, wait for a moment and then restart. If many times of this operation do not work, please contact service people.
3	E04	Outdoor unit protection	Turn off the unit, wait for a moment and then restart. If many times of this operation do not work, please contact service people.
4	P02	Compressor is over load	Turn off the unit, wait for a moment and then restart. If many times of this operation do not work, please contact service people.
5	P03	The temperature of evaporator coil of indoor unit is too low (when cooling)	Turn off the unit, remove the obstacles in the air-inlet and clean the air filter, then restart the unit. If many times of this operation do not work, please contact service people.
6	P04	The temperature of evaporator coil of indoor unit is too high (when heating)	Turn off the unit, remove the obstacles in the air-inlet and clean the air filter, then restart the unit. If many times of this operation do not work, please contact service people.
7	P05	The temperature of air outlet of indoor unit is too high (when heating)	Turn off the unit, remove the obstacles in the air-inlet and clean the air filter, then restart the unit. If many times of this operation do not work, please contact service people.

If the above procedures still do not work, please contact our local dealers or after sales service people, inform them your air conditioner model and trouble details, they will help you solve the problem. Please do not repair the air conditioner by yourself.

NOTE:

It is not a failure if :

1. The air smells because of feculent room air.
2. The refrigerant running noise is heard when the unit starts to run;
3. A 'Pee-pa' voice is heard when the unit starts or stops running.
4. There is maybe drop of water on the surface of the indoor unit when air humidity is over 85%.