

GCS16 SERIES UNITS 2 THROUGH 5 TON UNITS

GCS16 series units in the 2-5 ton cooling size were introduced in the summer of 1989. The units are packaged combination gas heat / dx cool units designed for both residential and commercial applications. Gas heat sections are available with Lennox' helical heat exchanger in 50,000 , 75,000 , 100,000 and 125,000 Btuh input sizes. Units are designed for rooftop or side of building installation with either bottom or horizontal discharge.

For commercial applications, the GCS16 is designed to

accept any of several different thermostat control systems with minimum field wiring. Control options such as economizer, warm up kit, Honeywell W973 control or Honeywell W7400 control connect to the unit with jack-plugs. When plugged in the controls become an integral part of the unit wiring. Commercial units are also equipped with a low voltage terminal strip to facilitate thermostat field wiring.

All specifications in this manual are subject to change.

TABLE OF CONTENTS

Introduction	Page 1	IX- MAINTENANCE	Page 38
Specifications	Pages 2-5	Lubrication	Page 38
Blower / Air Resistance Data	Pages 5-9	Filters	Page 39
Parts Arrangement	Pages 10-11	Heat Exchanger and Burner	Page 39
I- APPLICATION	Page 11	Combustion Air Blower and Flue	Pages 39-40
II- UNIT COMPONENTS	Page 11	Evaporator and Condenser Coil	Page 40
Control Box Components	Pages 11-14	Electrical	Page 40
Heating Components	Pages 15-22	X- ELECTRICAL CONNECTIONS	Page 40
Cooling Components	Pages 23-28	Power Supply and Field Wiring	Page 40
III- PLACEMENT AND INSTALLATION	Page 28	XI- ACCESSORIES	Page 41
IV- ELECTRICAL CONNECTIONS	Page 28	Lifting Lug Kit	Page 41
V- START UP - OPERATION	Page 28	RMF16 Roof Mounting Frame	Page 42
Preliminary Checks	Page 28	Economizers	Pages 42-49
Cooling / Heating Start Up	Page 29	RDE16-41 Duct Enclosure	Pages 49-51
Safety or Emergency Shut Down	Page 29	OAD16 Outdoor Air Damper	Page 51
Extended Period Shut Down	Page 29	L.P.G. Kit	Pages 52-53
VI- REFRIGERATION SYSTEM CHECKS	Page 29	Condenser Coil Guard Kit	Page 53
Gauge Manifold Attachment	Page 29	High Altitude Kit	Page 54
Charging	Pages 29-30	Compressor Crankcase Heater	Page 54
VII- HEATING SYSTEM SERVICE CHECKS	Page 31	Downflow Filter Kit	Page 54
A.G.A./C.G.A. Applications and Requirements	Page 31	Timed-Off Control Kit	Pages 54-55
Gas Piping	Page 31	Compressor Monitor	Page 55
Testing Gas Piping and Supply Pressure	Page 31	Low Ambient Kit	Pages 55-56
Check and Adjust Manifold Pressure	Page 31	Roof Curb Power Kit	Page 56
Proper Gas Flow	Page 32	Firestats	Page 57
High Altitude Derate	Page 32	Transitions and Supply / Return Diffusers	Page 58
Inshot Burner and Burner Cone	Pages 32-33	Status Panels	Pages 58-64
Burner Plate Gasket	Page 33	Commercial Controls Hardware	Page 65
Heat Exchanger	Page 34	Commercial Controls Systems	Pages 65-67
Ignition Control	Page 34	Controls Mounting Box and Bracket	Pages 67-78
Electrode Gap and Flame Sensing	Page 35	Clocks / Timers	Page 68
Combustion Air Blower	Page 35	XII- COMMERCIAL CONTROLS INSTALLATION	Page 69
Blower / Limit Control	Page 36	Night Kit and Night Relay	Page 69
VIII- INDOOR BLOWER OPERATION / ADJUSTMENT	Page 36	W7400 Control System	Pages 70-71
Blower Operation	Page 36	Warm-Up Kit	Page 72
Determining Unit CFM	Page 36	W973 Control System	Pages 73-74
Blower Speed Adjustment 208/230V	Pages 36-37	XIV- WIRING DIAGRAMS / OPERATION SEQUENCE	Page 75
Blower Speed Adjustment 460V and 575V	Page 38	Index and Introduction	Page 75
		Diagrams and Operation Sequence	Pages 76-134

SPECIFICATIONS
GCS16H RESIDENTIAL HORIZONTAL ONLY UNITS

Model No.		GCS16H-261-50	GCS16H-311-75
Heating capacity input (Btuh) - Natural Gas		50,000	75,000
Heating capacity output (Btuh) - Natural Gas		38,000	56,000
Heating capacity input (Btuh) - **LPG		50,000	67,500
Heating capacity output (Btuh) - **LPG		38,000	51,000
†A.F.U.E. Natural/**L.P.G.		79.0%/79.0%	78.1%/78.9%
California Seasonal Efficiency Natural/**L.P.G.		75.0%/75.0%	75.1%/75.7%
★ARI Standard 270 SRN (bels)		7.8	7.8
*ARI Standard 210 Ratings	Total Cooling Capacity (Btuh)	24,600	28,400
	Total unit watts	2620	3340
	SEER (Btuh/Watts)	10.0	9.70
	EER (Btuh/Watts)	9.4	8.5
Refrigerant (R-22) charge		3 lbs. 3 oz.	3 lbs. 3 oz.
Evaporator Blower	Blower wheel nominal diameter x width (in.)	9 x 8	9 x 8
	Motor horsepower	1/3	1/3
	Air volume range (cfm)	600 - 1000	750 - 1250
Evaporator Coil	Net face area (sq. ft.)	2.30	3.20
	Tube diameter (in.) & Number of rows	3/8 - 2	3/8 - 2
	Fins per inch	15	15
Condenser Coil	Net face area (sq. ft.)	4.60	4.60
	Tube diameter (in.) & Number of rows	3/8 - 2	3/8 - 2
	Fins per inch	20	20
Condenser Fan	Diameter (in.) & Number of blades	20 - 4	20 - 4
	Air volume (cfm)	1900	1900
	Motor horsepower	1/4	1/4
		Motor watts	320
Gas Supply Connections fpt (in.)	Natural	1/2	1/2
		**LPG	1/2
Recommended Gas	Natural	7	7
Supply Pressure (wc. in.)	**LPG	11	11
Condensate drain size mpt (in.)		3/4	3/4
Line voltage data	Recommended max. fuse size (amps)	30	30
	Minimum circuit ampacity	19.0	20.0
Electrical characteristics		208/230 volts - 60 hz - 1 phase	
**Optional LPG Conversion Kit		LB-62090DA	LB-62090DB
Optional Lifting Lug Kit		LB-62125DA	
Optional Condenser Coil Guards		LB-82199CA	
Optional Duct Enclosure		RDE16-41	
Number and size of filters (in.)		(1) 20 x 24 x 1 (fiberglass)	
Optional Roof Mounting Frame (used with RDE16-41 only)		RMF16-41	
Optional ††Economizer	Model	3 position	REMD16-41
	No.	Modulating	REMD16M-41
Dampers with Gravity Exhaust	Number and size of filters (in.)	Indoor	(1) 14 x 25 x 1 (polyurethane)
		Outdoor	(1) 14 x 25 x 1 (aluminum mesh)
Optional Ceiling Supply and Return Air Diffusers	Step Down		RTD9-65
	Flush		FD9-65
	Transition		SRTH16-65
Optional Outdoor Air Dampers (manual)		OAD3-46/65	

†Annual Fuel Utilization Efficiency based on DOE test procedures and FTC labeling regulations.

★Sound Rating Number in accordance with ARI Standard 270.

*Rated in accordance with ARI Standard 210 and DOE; 95°F outdoor air temperature and 80°F db/67°F wb entering evaporator air.

**For LPG units a field changeover kit is required and must be ordered extra.

††Two stage cooling thermostat required with economizer applications.

**SPECIFICATIONS
GCS16R RESIDENTIAL UNITS**

Model No.		GCS16R -411-50	GCS16R -411-100	GCS16R -511-125	GCS16R -651-75	GCS16R -651-125
Heating capacity input (Btuh) - Natural Gas		50,000	100,000	125,000	75,000	125,000
Heating capacity output (Btuh) - Natural Gas		37,000	78,000	95,000	58,000	95,000
Heating capacity input (Btuh) - **LPG		50,000	90,000	112,500	67,500	112,500
Heating capacity output (Btuh) - **LPG		37,000	70,000	85,000	52,000	85,000
†A.F.U.E. Natural/**L.P.G.		78.0%/78.0%	80.5%/81.0%	78.3%/78.5%	78.4%/78.4%	78.3%/78.5%
California Seasonal Efficiency Natural/**L.P.G.		73.1%/73.1%	77.1%/77.1%	75.0%/75.0%	72.6%/72.3%	75.0%/75.0%
★ARI Standard 270 SRN (bels)		7.8		8.0	8.0	
*ARI Standard 210 Ratings	Total Cooling Capacity (Btuh)	34,400		46,500	58,500	
	Total unit watts	3950		5410	6570	
	SEER (Btuh/Watts)	9.70		9.70	10.0	
	EER (Btuh/Watts)	8.70		8.60	8.90	
Refrigerant (R-22) charge		4 lbs. 12 oz.		5 lbs. 8 oz.	7 lbs. 0 oz.	
Evaporator Blower	Blower wheel nom. dia. x width (in.)	10 x 8		11-1/2 x 9	11-1/2 x 9	
	Motor horsepower	1/2		3/4	3/4	
	Air volume range (cfm)	900 - 1500		1200 - 2000	1500 - 2500	
Evaporator Coil	Net face area (sq. ft.)	4.10		5.30	6.30	
	Tube dia. (in.) & Number of rows	3/8 - 2		3/8 - 2	3/8 - 2	
	Fins per inch	15		15	15	
Condenser Coil	Net face area (sq. ft.)	Outer coil	8.70		14.30	14.30
		Inner coil	8.40		5.90	13.70
	Tube dia. (in.) & Number of rows	3/8 - 2		3/8 - 1.4	3/8 - 2	
	Fins per inch	20		20	20	
Condenser Fan	Diameter (in.) & Number of blades	20 - 4		24 - 4	24 - 4	
	Air volume (cfm)	2200		3880	3770	
Fan	Motor horsepower	1/6		1/4	1/4	
	Motor watts	240		340	360	
Gas Supply	Natural	1/2		1/2	1/2	
Connections fpt (in.)	**LPG	1/2		1/2	1/2	
Recommended Gas	Natural	7		7	7	
Supply Pressure (wc. in.)	**LPG	11		11	11	
Condensate drain size mpt (in.)		3/4		3/4	3/4	
Line voltage data	Recommended max. fuse size (amps)	45		60	60	
	Minimum circuit ampacity	27.0		36.0	42.0	
Electrical characteristics		208/230 volts - 60 hz - 1 phase				
**Optional LPG Conversion Kit		LB-62090DA	LB-62090DC	LB-62090DD	LB-62090DB	LB-62090DD
Optional Lifting Lug Kit		LB-62125DA				
Optional Condenser Coil Guards		LB-82199CB			LB-82199CC	
Optional Outdoor Air Dampers (manual)		OAD16-41			OAD16-65	

†Annual Fuel Utilization Efficiency based on DOE test procedures and FTC labeling regulations.

★Sound Rating Number in accordance with ARI Standard 270.

*Rated in accordance with ARI Standard 210 and DOE; 95°F outdoor air temperature and 80°F db/67°F wb entering evaporator air.

**For LPG units a field changeover kit is required and must be ordered extra.

SPECIFICATIONS - GCS16 COMMERCIAL UNITS

Model No.		GCS16-411-50 GCS16-413-50	GCS16-411-100 GCS16-413-100	GCS16-511-125 GCS16-513-125	GCS16-651-75 GCS16-653-75	GCS16-651-125 GCS16-653-125	
Heating capacity input (Btuh) - Natural Gas		50,000	100,000	125,000	75,000	125,000	
Heating capacity output (Btuh) - Natural Gas		37,000	77,000	95,000	58,000	95,000	
Heating capacity input (Btuh) - **LPG		50,000	90,000	112,500	67,500	112,500	
Heating capacity output (Btuh) - **LPG		37,000	67,000	85,000	52,000	85,000	
†A.F.U.E. Natural/**L.P.G.		78.0%/78.0%	79.7%/79.5%	78.3%/78.5%	78.4%/78.4%	78.3%/78.5%	
California Seasonal Efficiency Natural/**L.P.G.		73.1%/73.1%	76.4%/75.9%	75.0%/75.0%	72.6%/72.3%	75.0%/75.0%	
*ARI Standard 270 SRN (bels)		7.8		8.0	7.8		
*ARI Standard 210 Ratings	Total Cooling Capacity (Btuh)	34,400		46,500	58,500		
	Total unit watts	3950		5410	6570		
	SEER (Btuh/Watts)	9.70		9.70	10.0		
	EER (Btuh/Watts)	8.70		8.60	8.90		
Refrigerant (R-22) charge		4 lbs. 12 oz.		5 lbs. 8 oz.	7 lbs. 0 oz.		
Evaporator Blower	Blower wheel nominal dia. x width (in.)	10 x 8		11-1/2 x 9	11-1/2 x 9		
	Motor horsepower	1/2		3/4	3/4		
	Air volume range (cfm)	900 - 1500		1200 - 2000	1500 - 2500		
Evaporator Coil	Net face area (sq. ft.)	4.10		5.30	6.20		
	Tube dia. (in.) & No of rows & Fins/in.	3/8 - 2 - 15		3/8 - 2 - 15	3/8 - 2 - 15		
Condenser Coil	Net face area (sq. ft.) outer/inner	8.70/8.40		14.30/5.90	14.30/13.70		
	Tube diameter (in.) & Number of rows	3/8 - 2		3/8 - 2	3/8 - 2		
	Fins per inch	20		20	20		
Condenser Fan	Diameter (in.) & Number of blades	20 - 4		24 - 4	24 - 4		
	Air volume (cfm)	2200		3880	3770		
	Motor horsepower & Motor watts	1/6 - 240		1/4 - 340	1/4 - 360		
Gas Supply Conn. fpt (in.) - Natural & **LPG		1/2		1/2	1/2		
Recommended Gas	Natural	7		7	7		
	**LPG	11		11	11		
Supply Pressure (wc. in.)		11		11	11		
Condensate drain size mpt (in.)		3/4		3/4	3/4		
Line voltage Data (60hz)	Recommended max. fuse size (amps)	208/230v	1 ph	45	60	60	
			3 ph	30	40	45	
		460v - 3 ph		15	20	25	
	Minimum circuit ampacity	208/230v	1 ph	27.0	36.0	42.0	
			3 ph	20.0	26.0	29.0	
		460v - 3 ph		10.0	14.0	16.0	
Electrical characteristics		208/230 volts - 60 hz - 1 or 3 phase 460 or 575 volts - 3 phase					
**Optional LPG Conversion Kit		LB-62090DA	LB-62090DC	LB-62090DD	LB-62090DB	LB-62090DD	
Optional Lifting Lug Kit		LB-62125DA					
Optional Condenser Coil Guards		LB-82199CB			LB-82199CC		
Optional Downflow adaptor kit Model no, Filters		DF16-41, (1)16x25x1 (polyurethane)			DF16-65, (1) 20x25x1 (polyurethane)		
Optional Roof Mounting Frame		RMF16-41			RMF16-41 or RMF16-65		
Optional Economizer Dampers	Model No.	3 position		REMD16-41		REMD16-65	
		Modulating		REMD16M-41		REMD16M-65	
	No. & size of filters (in.)	Indoor	(1) 14 x 25 x 1 (polyurethane)			(1) 18 x 25 x 1 (polyurethane)	
		Outdoor	(1) 14 x 25 x 1 (aluminum mesh)			(1) 18 x 25 x 1 (aluminum mesh)	
Optional Horizontal Economizer Dampers	Model No.	3 position		EMDH16-41		EMDH16-65	
		Modulating		EMDH16M-41		EMDH16M-65	
	No. & size of filters (in.)	Indoor	(1) 20 x 24 x 1 (fiber glass)			(1) 16 x 25 x 1 & (1) 14 x 25 x 1 (fiber glass)	
		Outdoor	(1) 8 x 24 x 1 (aluminum mesh)			(1) 8 x 28 x 1 (aluminum mesh)	
Optional Outdoor Air Dampers (manual)		OAD16-41			OAD16-65		
Optional Ceiling Supply and Return Air Diffusers	Step Down		RTD9-65				
	Flush		FD9-65				
	Transition		SRT16-65				
Optional Controls Selection		Electromechanical Thermostat					
		Honeywell W973 Control System with T7067 Thermostat					
		Honeywell W7400 Control System with T7400 Thermostat					
		Flexstat Thermostat (discontinued as an option after August 1989)					
		Prostat Thermostat					
Optional Control Mounts		Downflow application			23H13		23H14
		Horizontal application			24H61		
†††Commercial Controls		Furnished - Factory Installed					
Optional Gravity Exhaust Dampers		GEDH16-65 (use with EMDH16 or EMDHM16)					
Optional Roof Curb Power Entry Kit		18H70 (1/2")					

† Annual Fuel Utilization Efficiency based on DOE test procedures and FTC labeling regulations.

†††Furnished as standard. Consists of: factory installed controls wiring harness, high pressure switch, loss of charge switch, low voltage terminal strip and compressor crankcase heater.

*Sound Rating Number in accordance with ARI Standard 270.

*Rated in accordance with ARI Standard 210 and DOE; 95°F outdoor air temperature and 80°F db/67°F wb entering evaporator air.

**For LPG units a field changeover kit is required and must be ordered extra.

ELECTRICAL DATA

Model No.		GCS16H-261	GCS16H-311	GCS16R-411 GCS16-411	GCS16R-511 GCS16-511	GCS16R-651 GCS16-651
Line Voltage Data - 60Hz. - 1ph		208/230v	208/230v	208/230v	208/230v	208/230v
Compressor	Rated Load Amps	12.0	13.5	17.6	23.5	27.6
	Locked Rotor Amps	57.0	77.4	87.0	118.0	135.0
Condenser Fan Motor	Full Load Amps	1.4	1.4	1.1	2.0	2.0
	Locked Rotor Amps	2.9	2.9	1.9	4.4	4.4
Evaporator Blower	Full Load Amps	2.2	2.2	3.9	4.6	4.6
	Locked Rotor Amps	4.6	4.6	8.3	10.0	10.0
Combustion Air Blower - FLA		0.75	0.75	0.75	0.60	††0.60
†Recommended Max. Fuse Size (amps)		30	30	45	60	60
Unit Power Factor		.96	.95	.95	.93	.95
*Minimum Circuit Ampacity		19.0	20.0	27.0	36.0	42.0

ELECTRICAL DATA

Model No.		GCS16-413		GCS16-513			GCS16-653		
Line Voltage Data - 60Hz. - 3ph		208/230v	460v	208/230v	460v	575v	208/230v	460v	575v
Compressor	Rated Load Amps	11.5	5.3	15.4	8.4	6.4	17.6	9.4	8.4
	Locked Rotor Amps	70	35	90	45	43	105	55	50
Condenser Fan Motor	Full Load Amps	1.1	0.75	2.0	1.1	1.8	2.0	1.1	1.8
	Locked Rotor Amps	1.9	1.3	4.4	2.2	2.2	4.4	2.2	2.2
Evaporator Blower	Full Load Amps	3.9	1.8	4.6	1.8	0.7	4.6	1.8	0.7
	Locked Rotor Amps	8.3	4.4	10.0	3.8	3.8	10.0	3.8	3.8
Combustion Air Blower - FLA		0.75	0.75	0.60	0.60	0.60	††0.60	††0.60	††0.60
†Recommended Max. Fuse Size (amps)		30	15	40	20	15	45	25	20
Unit Power Factor		.86	.86	.84	.87	.87	.86	.88	.88
*Minimum Circuit Ampacity		20.0	10.0	26.0	14.0	11.0	29.0	15.0	13.0

†Where current does not exceed 60 amps, HACR circuit breaker may be used in place of fuse.

NOTE - Extremes of operating range are plus and minus 10% of line voltage.

*Refer to National Electrical Code manual to determine wire, fuse and disconnect size requirements.

††0.75 in GCS16-650-75 and GCS16R-651-75.

ACCESSORY AIR RESISTANCE

Unit Model No.	Air Volume (cfm)	Total Resistance (inches water gauge)									
		REMD16 Economizer Downflow		EMDH16 Economizer Downflow		†RDE16-41 Duct Enclosure	†Downflow Filter Adaptor Kit	RTD9-65 Diffuser			FD9-65 Diffuser
		With Filter	Without Filter	With Filter	Without Filter			2 Ends Open	1 Side 2 Ends Open	All Ends & Sides Open	
GCS16H-261 GCS16H-311	800	.16	.01	---	---	.11	---	.15	.13	.11	.11
	1000	.20	.02	---	---	.19	---	.19	.16	.14	.14
	1200	.24	.03	---	---	.22	---	.25	.20	.17	.17
GCS16-410	800	.16	.01	.18	.01	---	.15	.15	.13	.11	.11
	1000	.20	.02	.20	.02	---	.18	.19	.16	.14	.14
	1200	.24	.03	.35	.03	---	.21	.25	.20	.17	.17
	1400	.28	.03	.50	.03	---	.25	.33	.26	.20	.20
GCS16-510 GCS16-650	1600	.16	.01	.30	.01	---	.15	.43	.32	.24	.24
	1800	.19	.02	.35	.02	---	.17	.56	.40	.30	.30
	2000	.23	.03	.40	.03	---	.20	.73	.50	.36	.36
	2200	.27	.04	.47	.04	---	.23	.95	.63	.44	.44

†Air resistance is with air filter in place.

BLOWER DATA

GCS16H-261-50 BLOWER PERFORMANCE @ 230v

External Static Pressure (in. wg.)	Air Volume (cfm) @ Various Speeds			
	High	Med. High	Med. Low	Low
0	1285	1065	935	770
.05	1255	1045	925	765
.10	1220	1025	915	760
.15	1190	1005	900	750
.20	1155	985	885	740
.25	1120	965	870	730
.30	1090	940	850	715
.40	1015	895	795	675
.50	940	835	715	620
.60	850	765	575	530
.70	775	670	505	---
.75	735	625	445	---

NOTE - All CFM measured external to unit without accessories.

GCS16H-261-50 BLOWER PERFORMANCE @ 208v

External Static Pressure (in. wg.)	Air Volume (cfm) @ Various Speeds			
	High	Med. High	Med. Low	Low
0	1230	970	825	645
.05	1210	950	815	640
.10	1180	935	810	635
.15	1155	915	790	630
.20	1130	895	780	625
.25	1105	870	765	610
.30	1075	850	747	600
.40	1020	805	705	560
.50	935	745	645	---
.60	895	675	580	---
.70	725	545	510	---
.75	665	490	470	---

NOTE - All CFM measured external to unit without accessories.

GCS16H-311-75 BLOWER PERFORMANCE @ 230v

External Static Pressure (in. wg.)	Air Volume (cfm) @ Various Speeds			
	High	Med. High	Med. Low	Low
0	1365	1055	885	735
.05	1335	1035	875	725
.10	1305	1015	860	710
.15	1275	995	845	695
.20	1245	975	830	---
.25	1215	955	815	---
.30	1185	930	795	---
.40	1115	880	750	---
.50	1035	815	695	---
.60	990	730	---	---
.70	840	650	---	---
.75	790	605	---	---

NOTE - All CFM measured external to unit without accessories.

GCS16H-311-75 BLOWER PERFORMANCE @ 208v

External Static Pressure (in. wg.)	Air Volume (cfm) @ Various Speeds			
	High	Med. High	Med. Low	Low
0	1280	915	785	---
.05	1255	900	775	---
.10	1230	885	760	---
.15	1210	875	745	---
.20	1180	860	730	---
.25	1155	835	715	---
.30	1120	825	695	---
.40	1065	770	---	---
.50	995	710	---	---
.60	905	---	---	---
.70	835	---	---	---
.75	790	---	---	---

NOTE - All CFM measured external to unit without accessories.

**GCS16(R)-411/413-50 BLOWER PERFORMANCE @ 230v
(With Horizontal Supply and Return Air Openings)**

External Static Pressure (in. wg.)	Air Volume (cfm) @ Various Speeds			
	High	Med. High	Med. Low	Low
0	1830	1700	1555	1385
.05	1810	1680	1535	1375
.10	1790	1660	1515	1365
.15	1770	1640	1495	1350
.20	1745	1620	1475	1335
.25	1720	1600	1455	1320
.30	1695	1575	1430	1305
.40	1640	1525	1385	1270
.50	1580	1475	1330	1225
.60	1515	1415	1270	1175
.70	1450	1355	1230	1175
.75	1410	1325	1200	1150

NOTE - All CFM measured external to unit without accessories.

**GCS16(R)-411/413-50 BLOWER PERFORMANCE @ 208v
(With Horizontal Supply and Return Air Openings)**

External Static Pressure (in. wg.)	Air Volume (cfm) @ Various Speeds			
	High	Med. High	Med. Low	Low
0	1800	1560	1385	1215
.05	1780	1540	1375	1205
.10	1760	1520	1360	1190
.15	1740	1500	1345	1180
.20	1715	1480	1330	1165
.25	1695	1460	1315	1150
.30	1665	1435	1300	1135
.40	1610	1385	1265	1100
.50	1550	1330	1220	1065
.60	1480	1260	1165	1020
.70	1410	1210	1110	980
.75	1370	1170	1080	955

NOTE - All CFM measured external to unit without accessories.

BLOWER DATA

GCS16(R)-411/413-50 BLOWER PERFORMANCE @ 230v
(With Downflow Supply and Return Air Openings)

External Static Pressure (in. wg.)	Air Volume (cfm) @ Various Speeds			
	High	Med. High	Med. Low	Low
0	1825	1705	1540	1380
.05	1810	1690	1525	1370
.10	1795	1670	1510	1360
.15	1775	1650	1495	1350
.20	1755	1630	1480	1340
.25	1735	1605	1460	1325
.30	1715	1585	1440	1310
.40	1660	1535	1390	1275
.50	1595	1465	1325	1225
.60	1505	1385	1235	1150
.70	1445	1345	1195	1100
.75	1400	1310	1160	1065

NOTE - All CFM measured external to unit without accessories.

GCS16(R)-411/413-50 BLOWER PERFORMANCE @ 208v
(With Downflow Supply and Return Air Openings)

External Static Pressure (in. wg.)	Air Volume (cfm) @ Various Speeds			
	High	Med. High	Med. Low	Low
0	1780	1545	1380	1210
.05	1760	1530	1370	1200
.10	1740	1515	1360	1190
.15	1720	1500	1345	1175
.20	1700	1485	1330	1160
.25	1675	1465	1315	1145
.30	1650	1445	1295	1125
.40	1600	1400	1255	1090
.50	1540	1350	1210	1050
.60	1470	1285	1150	990
.70	1400	1240	1120	945
.75	1360	1215	1095	920

NOTE - All CFM measured external to unit without accessories.

GCS16(R)-411/413-100 BLOWER PERFORMANCE @230v
(With Horizontal Supply and Return Air Openings)

External Static Pressure (in. wg.)	Air Volume (cfm) @ Various Speeds			
	High	Med. High	Med. Low	Low
0	1740	1585	1500	1370
.05	1710	1565	1475	1350
.10	1675	1545	1450	1330
.15	1645	1525	1425	1310
.20	1615	1490	1400	1290
.25	1580	1465	1375	1265
.30	1550	1440	1345	1240
.40	1485	1380	1290	1190
.50	1420	1320	1230	1135
.60	1350	1260	1165	1075
.70	1255	1165	1105	1015
.75	1220	1125	1070	980

NOTE - All CFM measured external to unit without accessories.

GCS16(R)-411/413-100 BLOWER PERFORMANCE @208v
(With Horizontal Supply and Return Air Openings)

External Static Pressure (in. wg.)	Air Volume (cfm) @ Various Speeds			
	High	Med. High	Med. Low	Low
0	1665	1500	1370	1220
.05	1650	1480	1350	1210
.10	1635	1460	1330	1195
.15	1615	1440	1310	1180
.20	1595	1420	1285	1165
.25	1570	1395	1265	1145
.30	1545	1370	1240	1125
.40	1485	1315	1190	1080
.50	1415	1255	1135	1030
.60	1335	1190	1080	975
.70	1245	1120	1020	910
.75	1195	1085	990	875

NOTE - All CFM measured external to unit without accessories.

GCS16(R)-411/413-100 BLOWER PERFORMANCE @ 230v
(With Downflow Supply and Return Air Openings)

External Static Pressure (in. wg.)	Air Volume (cfm) @ Various Speeds			
	High	Med. High	Med. Low	Low
0	1700	1580	1430	1315
.05	1665	1550	1420	1300
.10	1635	1520	1405	1285
.15	1600	1490	1390	1270
.20	1570	1460	1370	1250
.25	1540	1430	1345	1230
.30	1505	1400	1315	1215
.40	1430	1340	1260	1165
.50	1370	1280	1200	1110
.60	1300	1215	1130	1030
.70	1235	1150	1045	930
.75	1200	1115	1000	970

NOTE - All CFM measured external to unit without accessories.

GCS16(R)-411/413-100 BLOWER PERFORMANCE @ 208v
(With Downflow Supply and Return Air Openings)

External Static Pressure (in. wg.)	Air Volume (cfm) @ Various Speeds			
	High	Med. High	Med. Low	Low
0	1645	1480	1335	1175
.05	1615	1455	1320	1165
.10	1590	1435	1300	1150
.15	1560	1415	1280	1135
.20	1530	1390	1260	1120
.25	1500	1365	1240	1105
.30	1470	1340	1220	1090
.40	1410	1285	1170	1055
.50	1340	1225	1115	1020
.60	1270	1160	1060	985
.70	1195	1095	995	945
.75	1160	1055	965	925

NOTE - All CFM measured external to unit without accessories.

BLOWER DATA

GCS16(R)-511/513-125 BLOWER PERFORMANCE @ 230v
(With Horizontal Supply and Return Air Openings)

External Static Pressure (in. wg.)	Air Volume (cfm) @ Various Speeds				
	High	Med. High	Medium	Med. Low	Low
0	2700	2470	2235	1900	1650
.05	2675	2450	2225	1890	1640
.10	2650	2425	2210	1880	1630
.15	2625	2405	2200	1870	1620
.20	2595	2380	2185	1855	1610
.25	2570	2360	2165	1840	1600
.30	2535	2335	2150	1830	1585
.40	2480	2280	2110	1795	1550
.50	2410	2220	2085	1750	1510
.60	2340	2160	2000	1680	1455
.70	2255	2080	1965	1640	1410
.75	2215	2045	1940	1610	1385

NOTE - All CFM measured external to unit without accessories.

GCS16(R)-511/513-125 BLOWER PERFORMANCE @ 208v
(With Horizontal Supply and Return Air Openings)

External Static Pressure (in. wg.)	Air Volume (cfm) @ Various Speeds				
	High	Med. High	Medium	Med. Low	Low
0	2505	2250	2010	1715	1460
.05	2480	2230	1995	1705	1450
.10	2460	2215	1980	1695	1440
.15	2435	2200	1965	1685	1425
.20	2410	2180	1950	1675	1410
.25	2385	2155	1935	1660	1395
.30	2360	2135	1915	1645	1380
.40	2305	2090	1880	1615	1345
.50	2250	2030	1830	1570	1305
.60	2180	1970	1770	1520	1280
.70	2105	1920	1710	1460	1190
.75	2065	1895	1680	1435	1160

NOTE - All CFM measured external to unit without accessories.

GCS16(R)-511/513-125 BLOWER PERFORMANCE @ 230v
(With Downflow Supply and Return Air Openings)

External Static Pressure (in. wg.)	Air Volume (cfm) @ Various Speeds				
	High	Med. High	Medium	Med. Low	Low
0	2775	2505	2270	1970	1710
.05	2725	2465	2240	1950	1685
.10	2675	2430	2210	1925	1665
.15	2630	2395	2180	1905	1645
.20	2580	2360	2150	1885	1620
.25	2540	2320	2120	1860	1595
.30	2490	2285	2100	1840	1570
.40	2400	2220	2040	1795	1515
.50	2300	2145	1980	1740	1450
.60	2200	2070	1910	1680	1365
.70	2130	2000	1865	1620	1305
.75	2090	1965	1840	1590	1260

NOTE - All CFM measured external to unit without accessories.

GCS16(R)-511/513-125 BLOWER PERFORMANCE @ 208v
(With Downflow Supply and Return Air Openings)

External Static Pressure (in. wg.)	Air Volume (cfm) @ Various Speeds				
	High	Med. High	Medium	Med. Low	Low
0	2515	2265	1980	1735	1520
.05	2480	2240	1960	1720	1495
.10	2455	2215	1940	1700	1465
.15	2425	2190	1920	1675	1440
.20	2400	2165	1900	1650	1410
.25	2365	2140	1880	1625	1380
.30	2335	2115	1855	1600	1345
.40	2275	2065	1805	1550	1275
.50	2215	2010	1750	1475	1180
.60	2150	1950	1680	1365	---
.70	2095	1900	1610	1285	---
.75	2065	1875	1570	1230	---

NOTE - All CFM measured external to unit without accessories.

GCS16(R)-651/653-75 BLOWER PERFORMANCE @ 230v
(With Horizontal Supply and Return Air Openings)

External Static Pressure (in. wg.)	Air Volume (cfm) @ Various Speeds				
	High	Med. High	Medium	Med. Low	Low
0	2760	2515	2220	1945	1680
.05	2740	2500	2210	1935	1670
.10	2720	2485	2200	1930	1660
.15	2700	2465	2190	1920	1650
.20	2680	2450	2175	1910	1635
.25	2660	2430	2160	1900	1620
.30	2630	2410	2150	1885	1600
.40	2570	2360	2115	1860	1570
.50	2490	2300	2075	1820	1525
.60	2375	2225	2020	1770	1470
.70	2310	2170	1970	1730	1435
.75	2260	2135	1945	1710	1410

NOTE - All CFM measured external to unit without accessories.

GCS16(R)-651/653-75 BLOWER PERFORMANCE @ 208v
(With Horizontal Supply and Return Air Openings)

External Static Pressure (in. wg.)	Air Volume (cfm) @ Various Speeds				
	High	Med. High	Medium	Med. Low	Low
0	2565	2275	2000	1725	1485
.05	2545	2260	1990	1715	1475
.10	2525	2245	1980	1710	1465
.15	2505	2225	1965	1700	1450
.20	2485	2205	1955	1685	1435
.25	2465	2195	1940	1675	1425
.30	2440	2180	1920	1665	1405
.40	2390	2140	1890	1630	1370
.50	2340	2100	1855	1600	1330
.60	2280	2060	1820	1555	1280
.70	2235	2015	1765	1500	1225
.75	2210	2000	1745	1475	1195

NOTE - All CFM measured external to unit without accessories.

BLOWER DATA

GCS16(R)-651/653-75 BLOWER PERFORMANCE @ 230v
(With Downflow Supply and Return Air Openings)

External Static Pressure (in. wg.)	Air Volume (cfm) @ Various Speeds				
	High	Med. High	Medium	Med. Low	Low
0	2785	2530	2270	1980	1715
.05	2755	2510	2255	1965	1700
.10	2725	2485	2240	1950	1690
.15	2695	2455	2220	1935	1680
.20	2670	2430	2200	1920	1670
.25	2640	2400	2180	1905	1655
.30	2610	2375	2160	1895	1645
.40	2550	2320	2120	1865	1615
.50	2485	2265	2075	1825	1580
.60	2415	2200	2025	1780	1540
.70	2345	2165	1965	1765	1450
.75	2310	2140	1935	1745	1450

NOTE - All CFM measured external to unit without accessories.

GCS16(R)-651/653-75 BLOWER PERFORMANCE @ 208v
(With Downflow Supply and Return Air Openings)

External Static Pressure (in. wg.)	Air Volume (cfm) @ Various Speeds				
	High	Med. High	Medium	Med. Low	Low
0	2585	2280	2025	1815	1560
.05	2565	2265	2010	1800	1550
.10	2545	2245	2000	1785	1535
.15	2520	2230	1980	1770	1525
.20	2495	2210	1960	1750	1510
.25	2470	2195	1945	1735	1495
.30	2445	2175	1930	1720	1480
.40	2395	2140	1890	1680	1450
.50	2335	2095	1850	1645	1415
.60	2275	2050	1810	1600	1375
.70	2240	2015	1765	1570	1305
.75	2215	1995	1745	1550	1280

NOTE - All CFM measured external to unit without accessories.

GCS16(R)-651/653-125 BLOWER PERFORMANCE @ 230v
(With Horizontal Supply and Return Air Openings)

External Static Pressure (in. wg.)	Air Volume (cfm) @ Various Speeds				
	High	Med. High	Medium	Med. Low	Low
0	3025	2545	2295	2015	1680
.05	3010	2530	2280	2005	1675
.10	2995	2510	2265	1995	1670
.15	2980	2495	2250	1985	1665
.20	2960	2480	2235	1970	1655
.25	2945	2460	2220	1955	1645
.30	2925	2440	2200	1930	1635
.40	2880	2395	2160	1875	1605
.50	2825	2340	2110	1805	1555
.60	2765	2265	2025	1725	1475
.70	2695	2200	1985	1630	1450
.75	2665	2160	1950	1575	1425

NOTE - All CFM measured external to unit without accessories.

GCS16(R)-651/653-125 BLOWER PERFORMANCE @ 208v
(With Horizontal Supply and Return Air Openings)

External Static Pressure (in. wg.)	Air Volume (cfm) @ Various Speeds				
	High	Med. High	Medium	Med. Low	Low
0	2605	2315	2080	1730	1505
.05	2585	2295	2065	1720	1505
.10	2570	2275	2050	1710	1485
.15	2550	2255	2030	1700	1475
.20	2530	2235	2010	1685	1465
.25	2505	2215	1990	1670	1450
.30	2480	2190	1975	1660	1430
.40	2430	2140	1930	1630	1400
.50	2370	2085	1880	1600	1345
.60	2290	2015	1810	1560	1260
.70	2275	2015	1740	1500	1195
.75	2250	1935	1705	1470	1155

NOTE - All CFM measured external to unit without accessories.

GCS16(R)-651/653-125 BLOWER PERFORMANCE @ 230v
(With Downflow Supply and Return Air Openings)

External Static Pressure (in. wg.)	Air Volume (cfm) @ Various Speeds				
	High	Med. High	Medium	Med. Low	Low
0	2740	2520	2270	2025	1710
.05	2715	2495	2250	2005	1690
.10	2685	2470	2230	1980	1670
.15	2655	2445	2210	1960	1650
.20	2630	2420	2190	1935	1635
.25	2600	2395	2170	1910	1615
.30	2570	2370	2150	1885	1595
.40	2510	2320	2100	1835	1550
.50	2450	2255	2080	1780	1500
.60	2375	2185	1995	1755	1440
.70	2305	2120	1935	1675	1355
.75	2265	2080	1900	1695	1390

NOTE - All CFM measured external to unit without accessories.

GCS16(R)-651/653-125 BLOWER PERFORMANCE @ 208v
(With Downflow Supply and Return Air Openings)

External Static Pressure (in. wg.)	Air Volume (cfm) @ Various Speeds				
	High	Med. High	Medium	Med. Low	Low
0	2560	2280	2055	1780	1525
.05	2540	2265	2035	1765	1510
.10	2520	2250	2025	1745	1485
.15	2495	2235	2005	1725	1470
.20	2470	2220	1990	1710	1450
.25	2445	2200	1970	1695	1430
.30	2420	2185	1950	1675	1410
.40	2365	2145	1910	1635	1390
.50	2300	2095	1860	1595	1325
.60	2225	2030	1805	1550	1300
.70	2155	1960	1725	1485	1225
.75	2110	1930	1690	1460	1195

NOTE - All CFM measured external to unit without accessories.

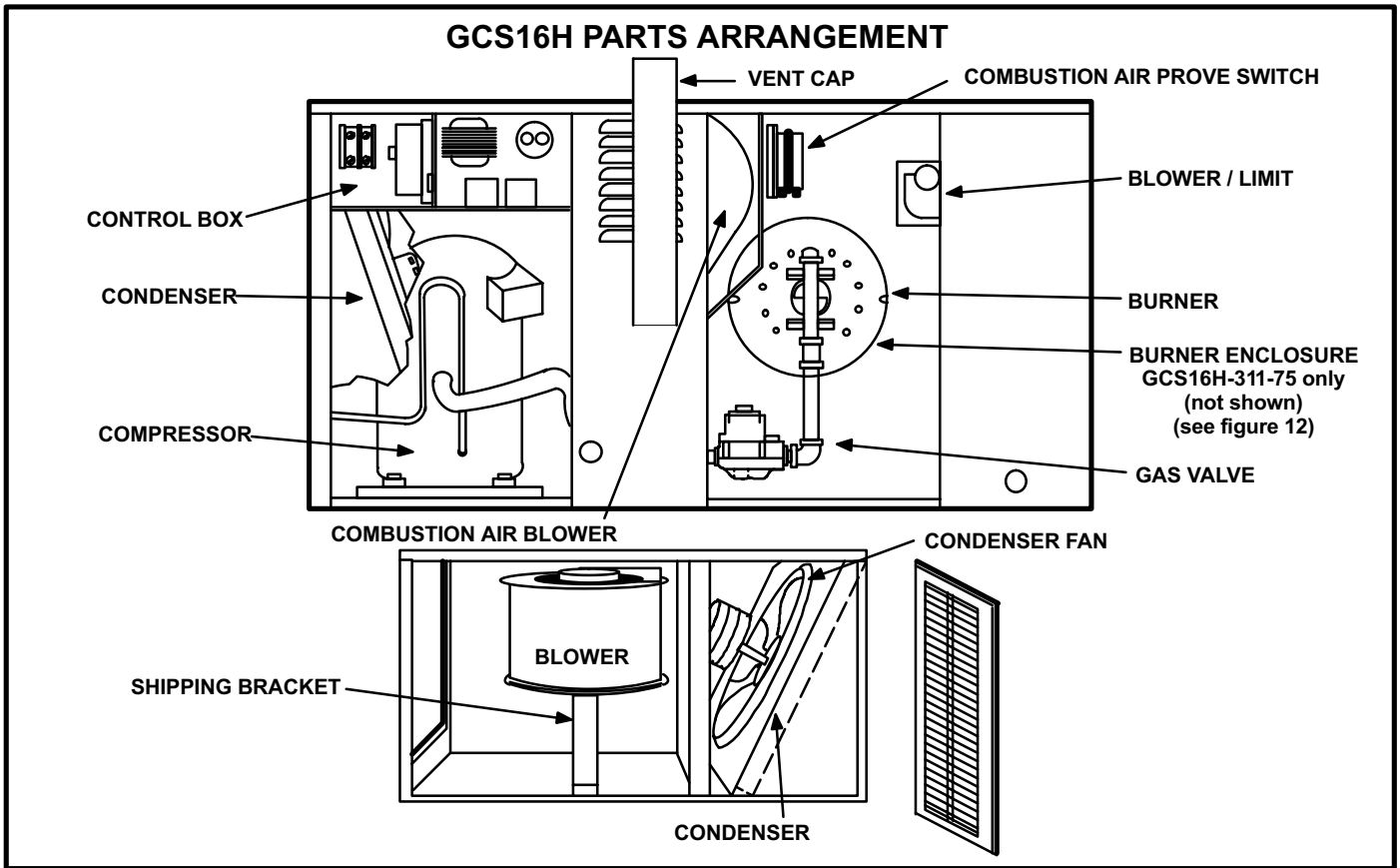

FIGURE 1

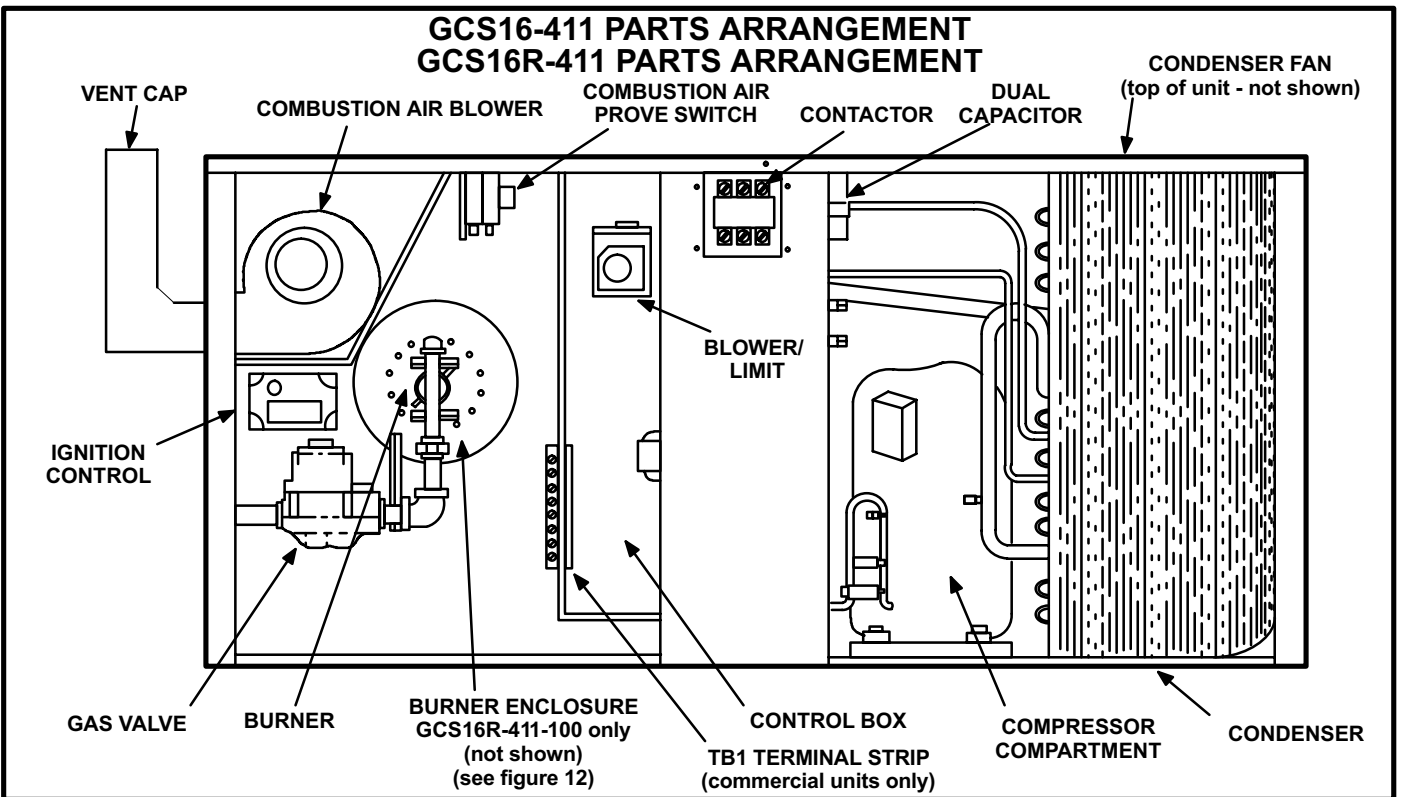

FIGURE 2

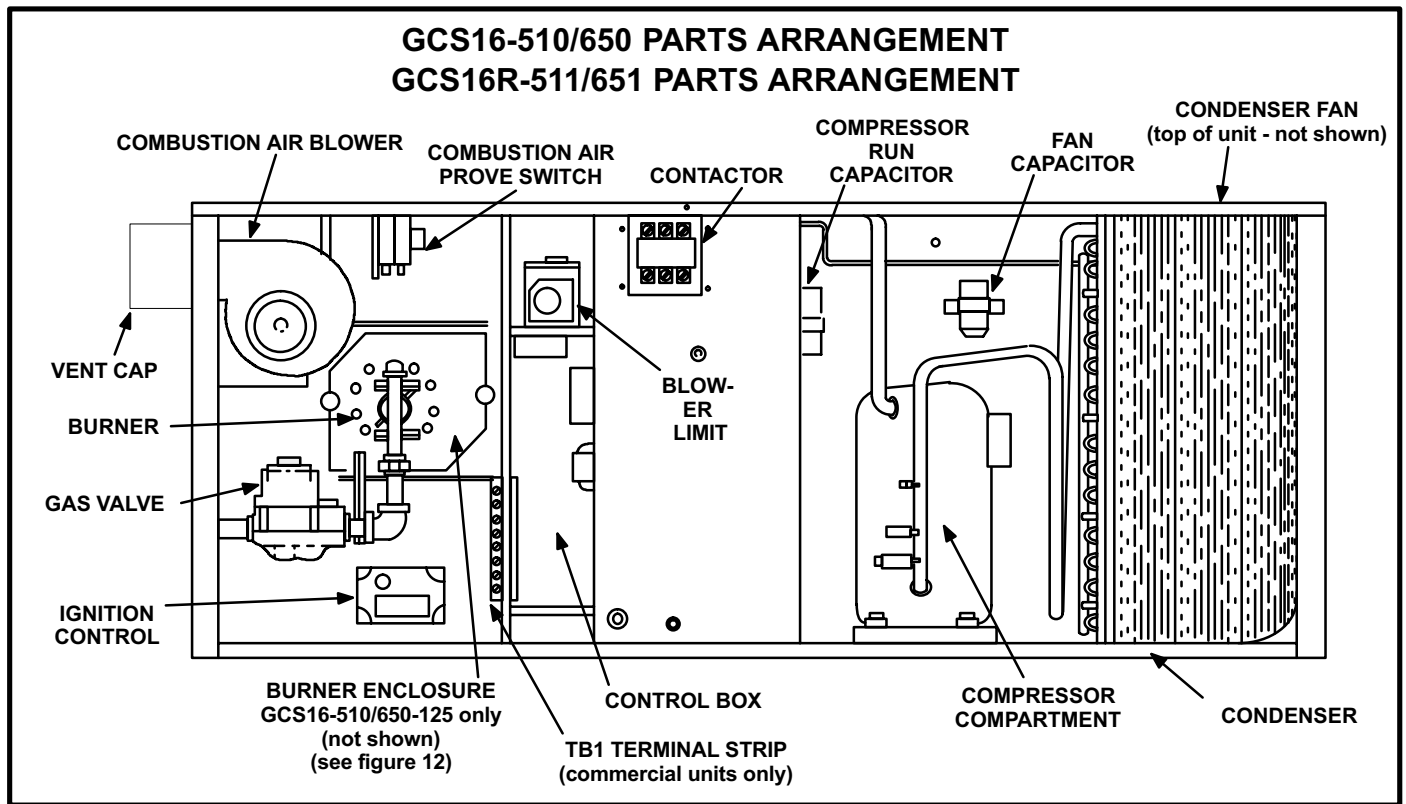

FIGURE 3

I-APPLICATION

GCS16 2-5 ton units are available in three model and three cabinet sizes (refer to the Engineering Handbook for more specific application data). GCS16H models are available only in the smallest cabinet and are applicable for residential installations with horizontal supply and discharge air only. GCS16H units are single-phase only and are not equipped for installation of Lennox' optional thermostat control systems. GCS16R models are residential only units available in both the small and large convertible (downflow or horizontal) cabinets. GCS16R models, like the GCS16H models, are single-phase only and are not equipped for installation of Lennox' optional thermostat control systems. GCS16 models are residential or commercial units available in single or three-phase and available in both the small and large convertible (downflow or horizontal) cabinets. GCS16 models are factory equipped with the hardware required for installing Lennox' optional thermostat control systems. Lennox' optional thermostat control systems are the same controls, harnesses, and harness plugs used in GCS16 7-1/2 ton and larger units. For example, a Honeywell W973 control will plug in to a GCS16-411 as easily as it will plug in to a GCS16-1853 (and no field wiring is required for either).

II-UNIT COMPONENTS

GCS16 unit components are shown in figures 1, 2 and 3.

A-Control Box Components

GCS16H control box is shown in figure 4. The control box is located in the upper portion of the compressor compartment behind the compressor compartment access panel. Note that the burner ignition control is located inside the control box (not in the heating compartment). The condenser fan has its own access panel located on the opposite side of the unit.

GCS16R-411 and GCS16-410 control box is shown in figure 5. GCS16R-511/651 and GCS16-510/650 control box is shown in figure 6. In both units, the control box is located in the heating compartment behind the heating compartment access panel. Note that the compressor contactor is located behind a separate access panel on the mullion adjacent to the compressor compartment access panel. The condenser fan can be accessed by removing the fan grill located on top of the unit.

The indoor blower access panel (all units) is located on the opposite side of the unit from the heating compartment access. Figure 1 shows typical blower compartment access.

GCS16H CONTROL BOX

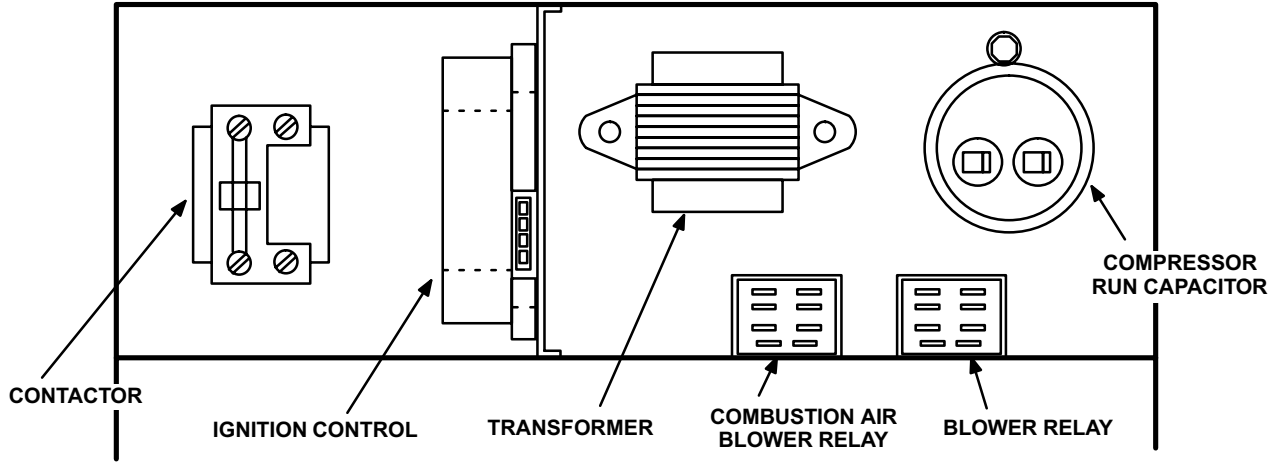

FIGURE 4

GCS16R-411 / GCS16-410 CONTROL BOX

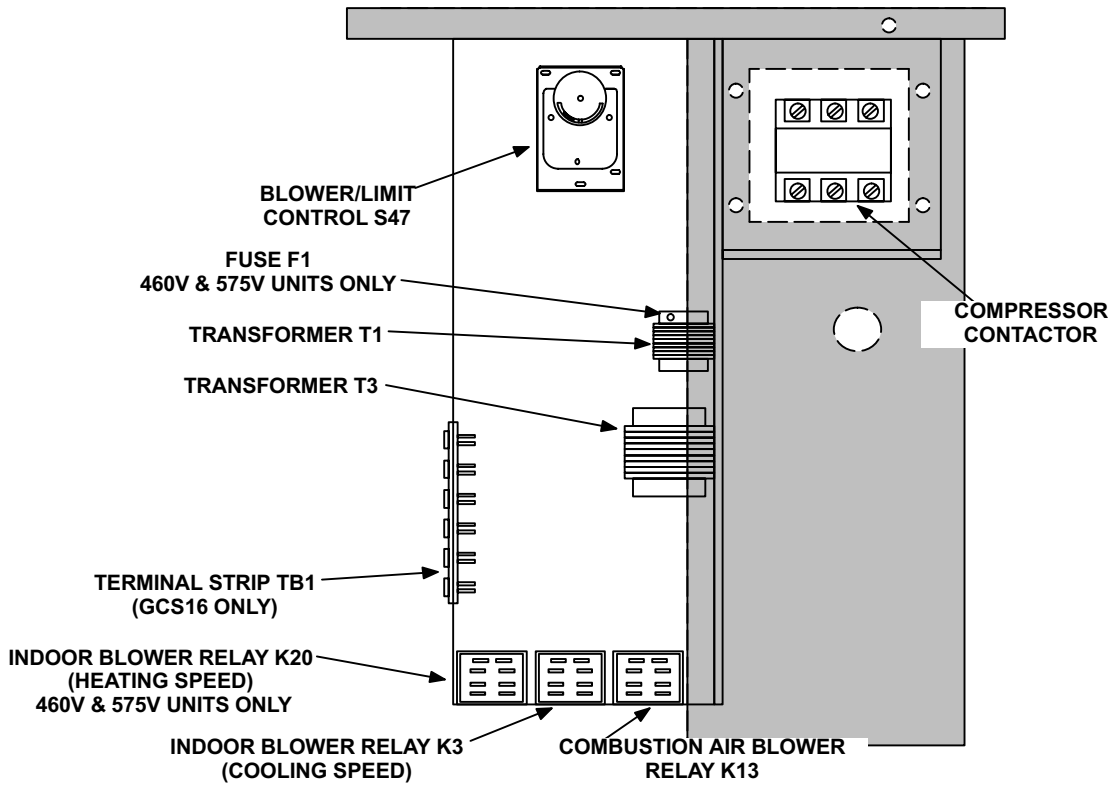

FIGURE 5

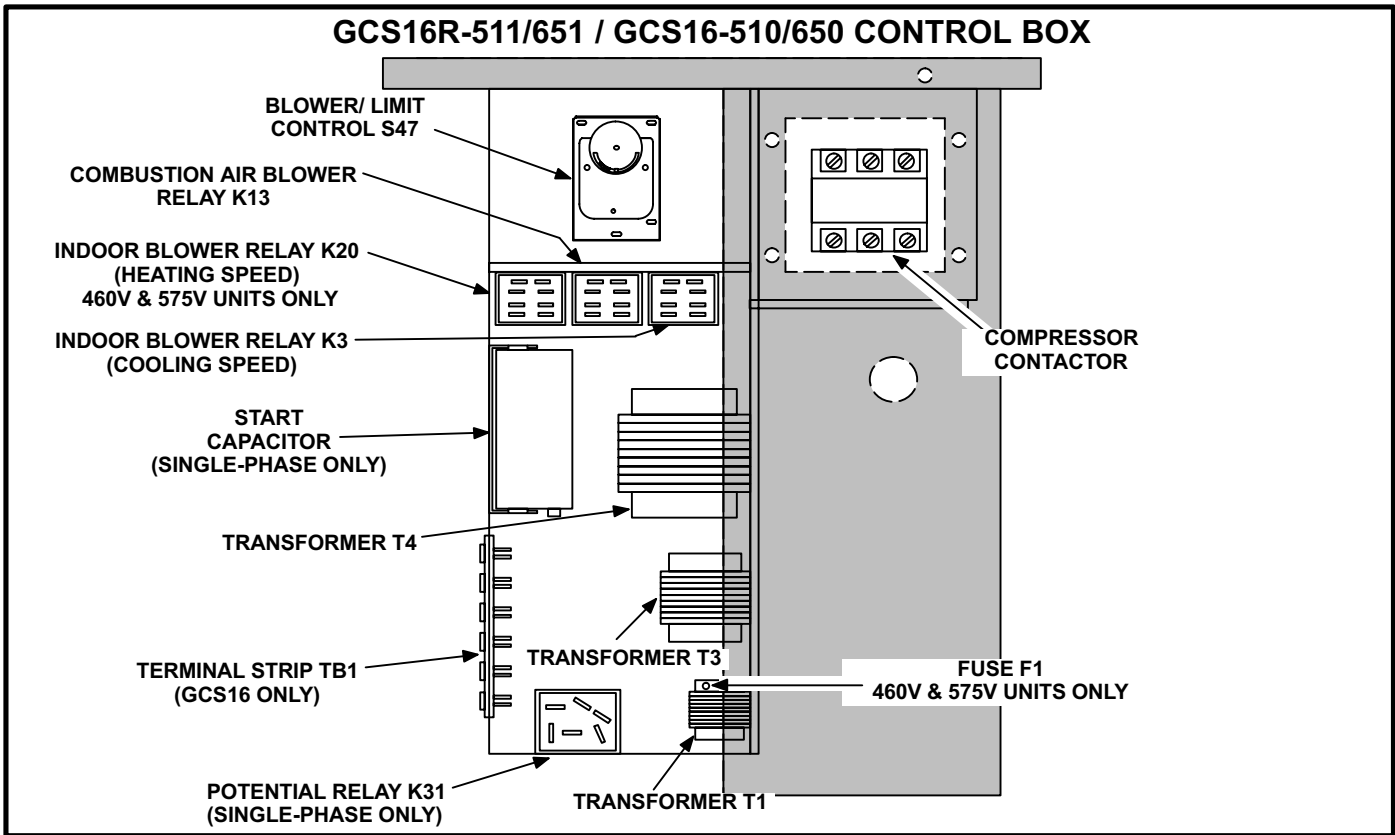

FIGURE 6

1-Terminal Strip TB1

All GCS16 commercial units are equipped with a low voltage terminal strip (TB1). The strip is used for making up all indoor thermostat and outdoor unit low voltage control wiring connections (see figures 5 and 6). The terminal strip is located in the burner compartment on the outside panel of the control box.

2-Transformer T1

All GCS16 series units use a single line voltage to 24VAC transformer mounted in the control box. The transformer supplies power to control circuits in the unit. Transformers are rated at 45VA. 208/230 (P) voltage transformers use two primary voltage taps as shown in figure 7.

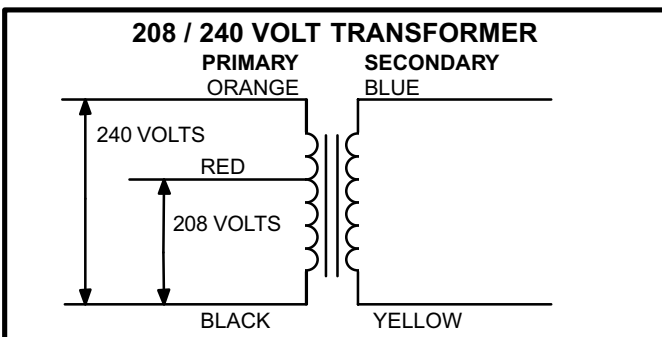

FIGURE 7

3-Transformer Fuse F1

208/230 (P) voltage transformers are not equipped with internal secondary voltage overcurrent protection. 460 (G) voltage and 575 (J) voltage transformers are equipped with an integral fuse connected in series with the blue secondary voltage wire. The fuse may be accessed outside the transformer and is rated 2.5A for 460 volt units and 3.5A for 575 volt units.

4-Transformer T3

460 (G) and 575 (J) voltage units use a line voltage to 230V autotransformer to power the combustion air blower. The autotransformer is connected directly to line voltage and is powered at all times. It has an output rating of 0.5A.

5-Transformer T4

575 (J) voltage units use a line voltage to 460V autotransformer to power the indoor blower. This autotransformer is also connected directly to line voltage and is powered at all times. It has a maximum VA rating of 3.4A.

6-Cooling Contactor K1

K1 is a 24V to line voltage contactor used to energize the compressor and condenser fan in response to thermostat demand. Three-phase units use three-pole-double-break contactors. Single-phase units use single-pole contactors.

DANGER - ALL SINGLE-PHASE UNITS USE SINGLE-POLE CONTACTORS. ONE LEG OF COMPRESSOR, CAPACITOR AND CONDENSER FAN ARE CONNECTED TO LINE VOLTAGE AT ALL TIMES. POTENTIAL EXISTS FOR ELECTRICAL SHOCK RESULTING IN INJURY OR DEATH. REMOVE ALL POWER AT DISCONNECT BEFORE SERVICING.

NOTE - Contactor K1 is energized by the thermostat control system. Depending on the control system installed, the contactors may or may not be immediately energized upon demand. Refer to the operation sequence for the control system installed.

7-Indoor Blower Relay K3 (Cooling Speed)

208/230 volt units use a single 2PDT relay to energize the indoor blower motor. 460 volt and 575 volt units use a single 3PDT relay. The relay coil is energized by blower demand from indoor thermostat terminal "G" (cooling demand or fan switch in "ON" position). When the coil is energized, a set of N.O. contacts closes to energize the blower motor on high speed. When de-energized, a set of N.C. contacts allows the fan / limit control relay to energize the blower on heating speed (refer to unit wiring diagram).

460 (G) and 575(J) voltage units use a unique blower motor. The motor utilizes a set of N.C. relay K3 contacts to complete an internal circuit when the motor is on low or medium (heating) speed.

8-Potential Relay K31

Relay K31 is used in single-phase -510 and -650 units only and is located in the control box. It is a potential relay which controls the operation of the starting circuit. The relay is normally closed when the compressor (contactor K1) is de-energized. Capacitor (C7) is connected to a set of N.C. K31 contacts and is used to assist the compressor in starting. When K1 energizes, the compressor immediately begins startup. K31 remains de-energized during compressor start-up and the start capacitor (C7) remains in the circuit. As the compressor gains speed K31 is energized by electromotive forces generated by the compressor. When K31 energizes, its contacts open to take the start capacitor out of the circuit.

9-Combustion Air Blower Relay K13

Relay K13 is a DPDT relay located inside the control box. K13 is energized by heating demand from the thermostat and is energized throughout the heating demand. When energized, K13 normally open contacts close to energize the combustion air blower and begin a heating sequence. A differential pressure "prove" switch connected to the combustion air blower in turn energizes the ignition control and gas valve. A separate set of K13 contacts close to energize the economizer.

10-Indoor Blower Relay K20 (Heating Speed) used in 460V and 575V units only

Relay K20 is a 3PDT relay also located in the control box. Relay K20 is energized when time-delay relay K25 closes. K20 is used to energize the blower on heating speed. When relay K20 is energized, a set of contacts close to energize the blower.

B-Heating Components (Figure 8)

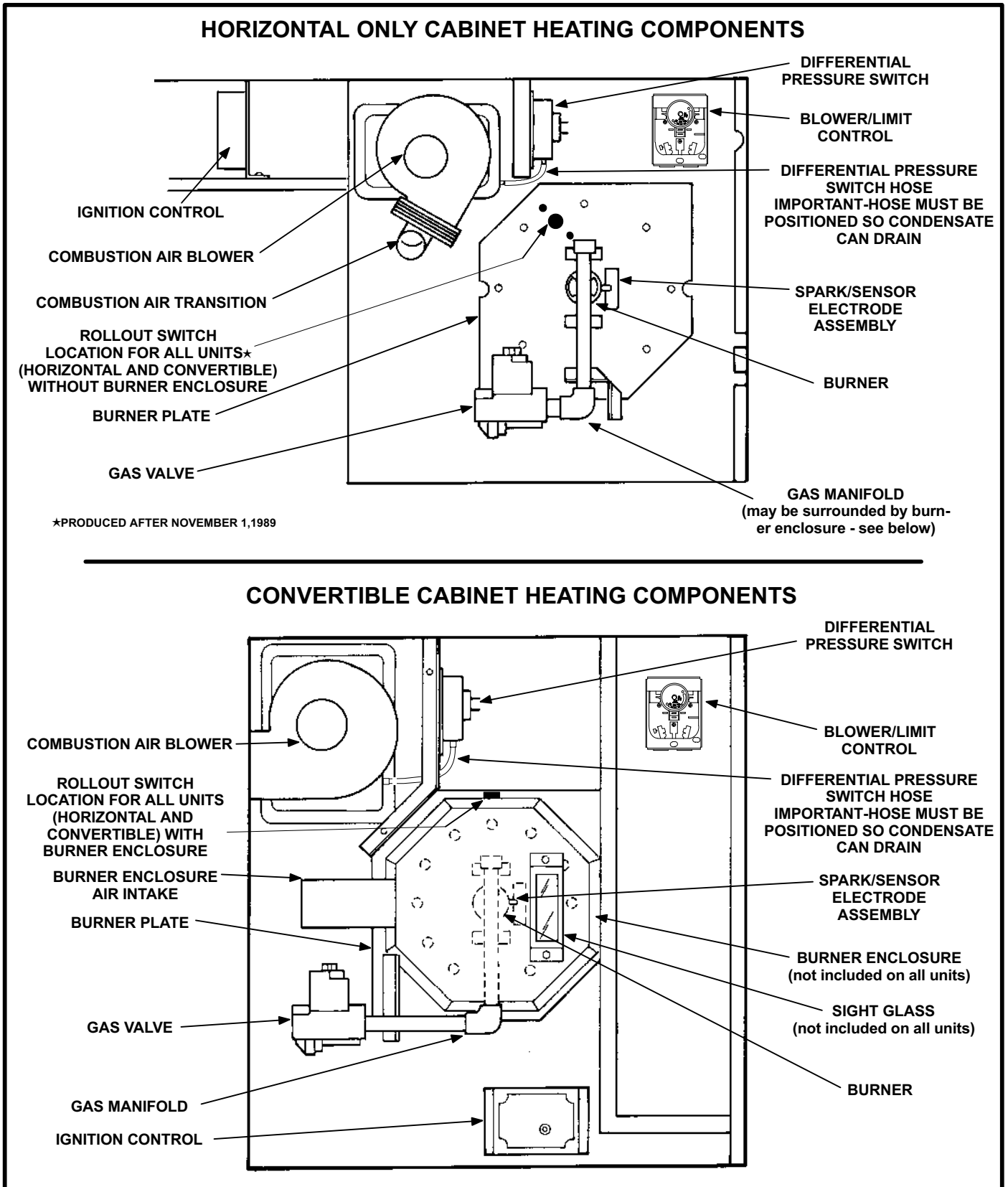

FIGURE 8

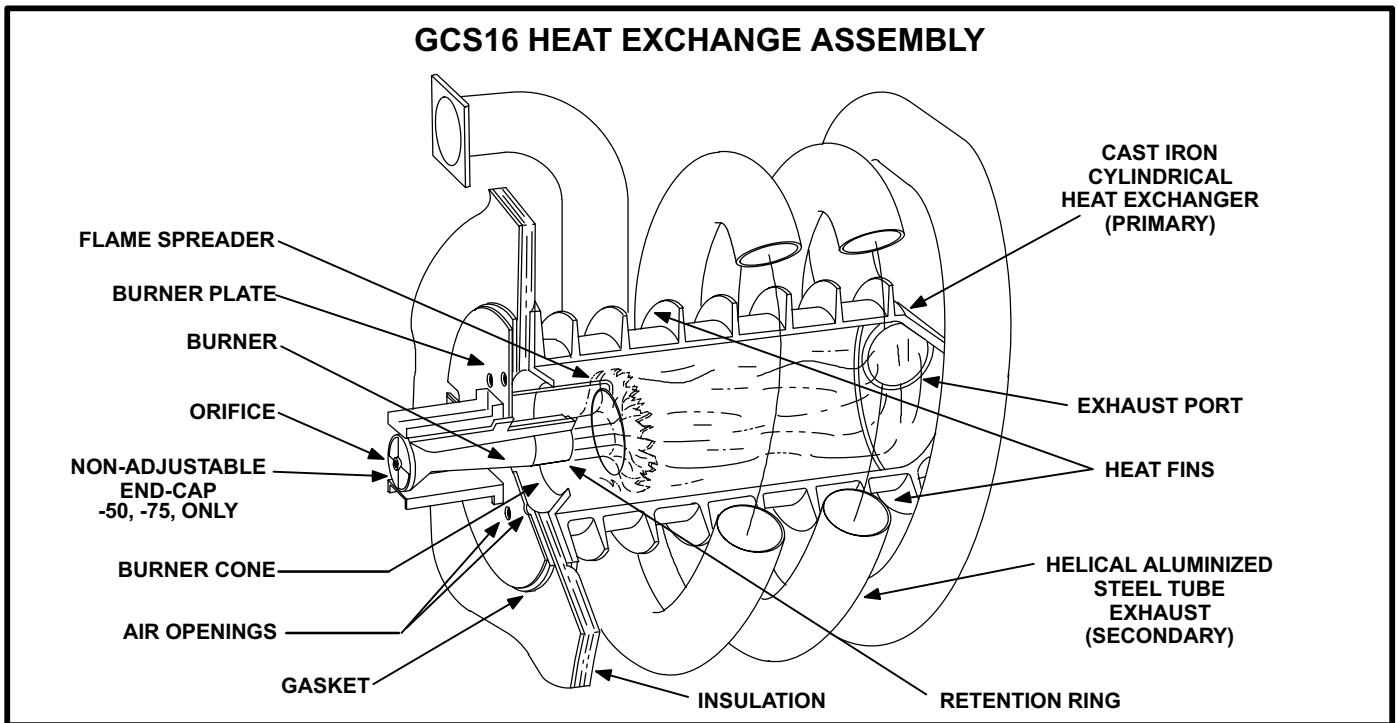

FIGURE 9

1-Heat Exchanger (Figure 9)

All units use a cast iron cylindrical heat exchanger (primary) encircled by helical aluminized steel tube exhaust (secondary). Heat is transferred to the airstream from all surfaces of the primary and secondary. A single inshot burner is directed at a spreader in the heat exchanger and a combustion air blower is used to pull combustion air through the heat exchanger. Heat exchangers are configured as shown in Table 1.

TABLE 1

Btuh	Heat Exchanger (Primary) Size	Heat Exchanger (Secondary) No. of Wraps Around Primary
50,000	Small	2
75,000	Small	3
100,000	Large	4
125,000	Large	5

2-Burner Assembly (Figures 10 and 11)

The burner is controlled by the spark electrode, flame sensing electrode, gas valve GV1 and combustion air blower B6. The spark electrode, flame sensing electrode and gas valve GV1 are directly controlled by ignition control A3. Ignition control A3 is controlled by combustion air blower B6. Combustion air blower B6 is controlled by heating demand from the thermostat or control system.

The burner is factory set and does not require adjustment. Burner end caps (if used - see figure 9) are non-adjustable. Flame can be viewed through air holes in the burner plate. A peep hole is provided in the burner access panel on units without a burner enclosure. If a burner enclosure is used, a flame viewing glass is provided in the enclosure.

Combustion takes place at the heat exchanger entrance. Combustion air is pulled through the burner by the combustion air blower (B6). Air is mixed with fuel in the burner. The mixture is then ignited by the spark electrode and the resultant flame is directed against a flame spreader. The spreader disrupts and spreads the flame. The burner cone surrounding the entrance to the heat exchanger directs additional combustion air into the flame. A flame retention ring located in the burner end is used to keep flame from lifting off the burner head. As hot exhaust gases are drawn through the heat exchanger by the combustion air blower, exhaust gases are expelled from the heat exchanger secondary and fresh air/gas mixture is drawn in through the burner and supply air holes. Supply air blower B3, controlled by blower relay K25 forces air across all surfaces of the heat exchanger primary and secondary to extract the heat of combustion.

a-Burners

All units use an inshot burner (see figures 10 and 11). A flame retention ring located in the burner end is used to keep flame from lifting off the burner. The flame is aimed at a round flame spreader located in the combustion chamber. The spreader distributes the flame evenly around the circumference of the heat exchanger. Burners in 50,000 and 75,000 Btuh heat exchangers use a separate non-adjustable end-cap (see figure 10). Burners in 100,000 and 125,00 Btuh heat exchangers do not use an end-cap (see figure 11).

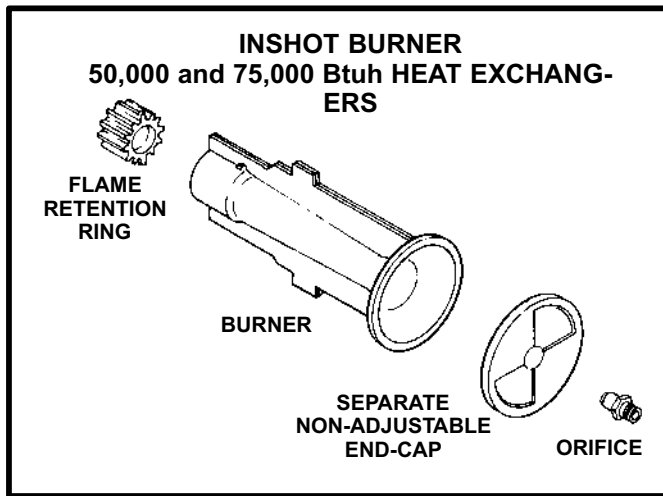

FIGURE 10

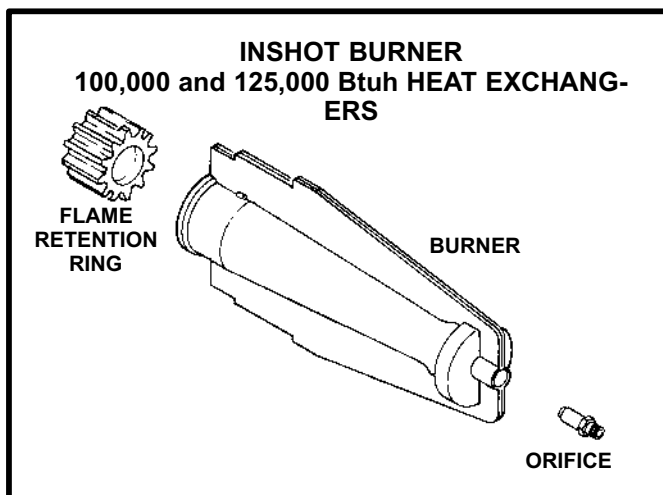

FIGURE 11

b-Orifice

All GCS16 units use an orifice which is precisely matched to the burner input. The burner is supported by the orifice and will easily slide off for service.

Each orifice and burner are sized specifically to the unit. Refer to Lennox Repair Parts Listing for correct sizing information.

3-Burner Enclosure

The following units are equipped with a burner enclosure surrounding the burner assembly:

GCS16R-510-125, GCS16-510-125,
GCS16R-650-125, GCS16-650-125,
GCS16R-411-100, & GCS16H-311-75.

The enclosure is used to reduce sound levels in the burner area. The enclosure consists of a metal wrapper surrounding the burner assembly and a glass flame viewing window (see figure 12).

The burner can be inspected and the spark/sensor electrode removed by removing the burner enclosure sight glass plate. If the burner must be removed or the orifice accessed, the burner enclosure must be removed. Burner enclosure and burner removal is detailed in the maintenance section of this manual.

Units equipped with burner enclosure are also equipped with flame rollout switch. The switch provides unit protection by shutting down the unit when flame rollout is sensed.

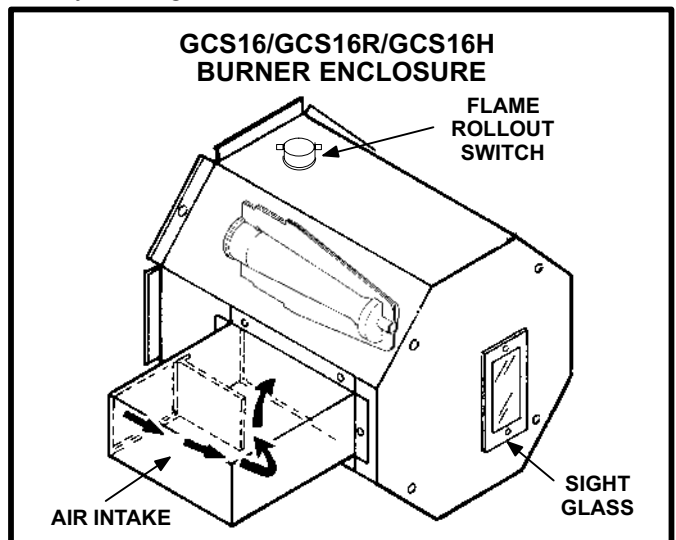

FIGURE 12

4-Blower / Limit Control: High Temperature Limit S10, Blower Control K25

A combination blower/limit control with a bimetal sure-start heater (figure 13) is used to control blower operation and protect unit from high temperature operation. It is located in the upper end of the heating vest panel. The blower control heater is a resistive type bimetal heat relay (K25) used to reduce the time between blower demand and blower start-up. It is energized with the heating demand.

Internal contacts K25 are used to coordinate blower operation with burner operation. The N.O. contacts are actuated by a bimetal spring when temperature rise in the heating compartment (in addition to heat added by the sure-start heater) is sufficient. The blower cycles on 20 to 90 seconds after the start of a heating demand and cycles off 120 to 240 seconds after heat demand is satisfied (when bimetal switch cools). On-time will vary, depending on the voltage applied to the bimetal heater and on the temperature surrounding the K25 switch. The relay is SPST.

The blower control has a factory off setting of 90°F. This control can be field adjusted. In some cases, an unusual duct design can cause the indoor blower to cycle on after the heat demand is satisfied. If this situation occurs, the "Fan Off" setting on the blower/limit control should be set below 90°F. See figure 13.

NOTE - Blower "OFF" settings above 90°F will cause the blower to recycle frequently (after a heating cycle) due to residual heat in the heat exchange assembly. Blower "OFF" settings above 90°F may also cause nuisance trips of secondary limit S10.

Adjustment procedure is outlined in "Heating System Service Checks" section.

Primary limit S10 contacts de-energize the ignition control when excessive temperature is reached in the blower compartment. The N.C. limit is a SPST auto-reset switch. It is fixed in position for a maximum discharge air temperature. The limit is factory preset to trip on a temperature rise and automatically reset on a temperature fall. On a temperature rise terminals 1-3 open to de-energize the ignition circuit. Table 2 shows factory settings. This is a safety shut-down function of the unit.

TABLE 2

LIMIT CONTROL S10	
Unit Input Thousand Btuh	High Limit Cutout ± 10°F
50	160°F
75	170°F
100	170°F
510-125	150°F
650-125	160°F

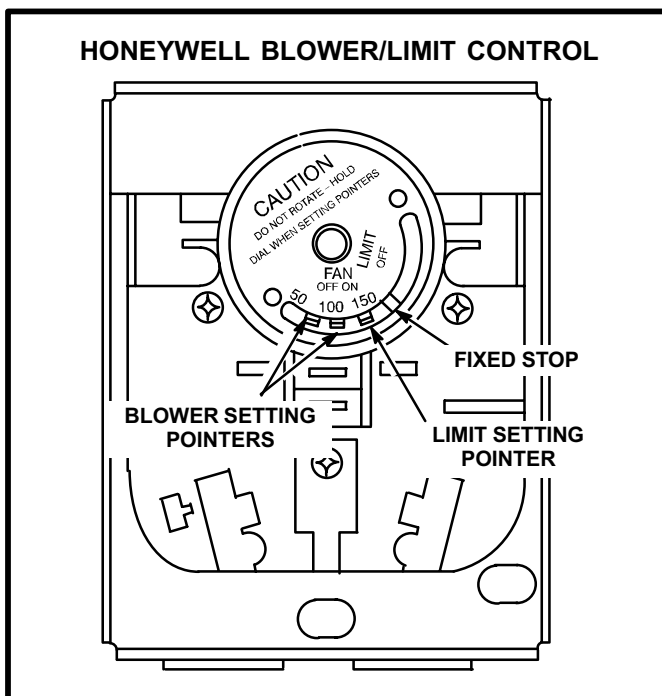

FIGURE 13

5-Secondary Limit S21 100,000 Btuh Heat Exchangers Only

All GCS16-410-100 and GCS16R-411-100 units are equipped with a secondary high temperature limit located on the blower scroll (see figure 14). The limit is a SPST auto-reset temperature which opens (terminals 1-3) on a temperature rise. It is electrically connected in series with the ignition control. The limit is used to de-energize the ignition control and shut down the unit when temperature in the blower scroll becomes too high. The limit is factory preset to open at 170°F±5°F on a temperature rise and close at 130°F±10°F on a temperature fall. It is not adjustable. This is a safety shut-down function of the unit.

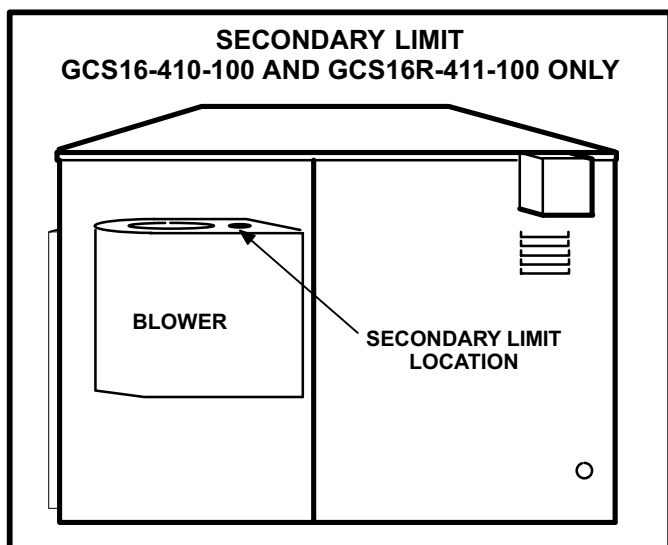

FIGURE 14

6-Flame Rollout Switch S47

Flame rollout switch S47 is a high temperature limit located just above the burner air intake opening in the burner enclosure (see figure 12). The limit is a N.C. SPST resettable limit connected in series with ignition control A3. When S47 senses flame rollout, the ignition control immediately stops ignition and closes the gas valve. The switch is factory set and cannot be adjusted.

Initially, only units equipped with a burner enclosure were equipped with rollout switch S47 (see section 3- Burner Enclosure and figure 12). In November 1989, rollout switch was added to all units. It is an A.G.A. mandated requirement on all gas furnaces produced after that date. In all 75,000, 100,000 and 125,000 Btuh heat exchanger units produced after November 1989, the switch is installed in a burner enclosure as shown in figure 12. In all 50,000 Btuh heat exchanger units produced after November 1989, the switch is installed as shown in figure 8.

7-Combustion Air Prove Switch S18

The combustion air prove switch (S18) is a SPST N.O. differential pressure switch used to monitor combustion air blower operation. A flexible hose connects one side of the switch to the blower housing. The other side of the switch is open to the atmosphere. The switch is wired in series with ignition control A3. Prove switch S18 closes when the combustion air blower reaches full speed to allow the ignition control to energize. This proves that the combustion air blower is operating and allows the heating cycle to continue.

The combustion air prove switch is factory set and is not adjustable. Factory settings are shown in Table 3.

TABLE 3

COMBUSTION AIR PROVE SWITCH FACTORY SETTING	
Unit	N.O., closes on pressure drop inches w.c.
GCS16H-261	0.45 ± 0.05
GCS16H-311	0.65 ± 0.05
GCS16R-411-50	0.45 ± 0.05
GCS16-411/413-50	0.45 ± 0.05
GCS16R-411-100	0.65 ± 0.05
GCS16-411/413-100	0.45 ± 0.05
GCS16R-511-125	0.90 ± 0.05
GCS16-511/513-125	0.90 ± 0.05
GCS16R-651-75	0.45 ± 0.05
GCS16-651/653-75	0.45 ± 0.05
GCS16R-650-125	0.90 ± 0.05
GCS16-651/653-125	0.90 ± 0.05

8-Combustion Air Blower B6

Combustion air blower B6 provides fresh air to the burner while clearing the combustion chamber of exhaust gases. The blower begins operating immediately upon receiving a thermostat demand and is de-energized immediately when thermostat demand is satisfied.

Blowers on 50K, 75K and 100K Btuh heat exchangers are manufactured by Lennox and can be disassembled for cleaning. Blowers on 125K Btuh heat exchangers are factory assembled as a unit and cannot be disassembled for cleaning.

Combustion air blower specifications are shown in table 4. All combustion air blower motors are sealed and cannot be oiled.

The tube connecting the switch to the blower flue box must be sloped in a manner that will prevent condensate from collecting in the tube. It is normal for a small amount of condensate to form in the tube during unit operation. The tube and switch must be allowed to drain accumulated condensate between thermostat demands. If the tube is positioned so that accumulated condensate is trapped in the tube, the unit may run improperly or may lock out.

TABLE 4

COMBUSTION AIR BLOWER						
Unit Input Btuh	Volts/ phase	Type	HP	RPM	Bearings	Misc.
50K 75K 100K	208/ 230/1	Shaded Pole 1-1/2 Stack	1/25	3200	Ball	Requires T3 when used in 460/575 volt units
125K	208/ 230/1	PSC	1/10	3200	Ball	Requires T3 when used in 460/575 volt units

9-Flue Vent (Figure 15)

WARNING - VENT CAP ASSEMBLY MUST BE INSTALLED WITHOUT MODIFICATION. ANY MODIFICATION TO THE VENT CAP ASSEMBLY OR FAILURE TO INSTALL ASSEMBLY CAN RESULT IN IMPROPER OPERATION AND WILL VOID THE AGA/CGA CERTIFICATION OF THE UNIT.

CAUTION - DO NOT START OR OPERATE UNIT UNLESS VENT CAP IS IN PLACE.

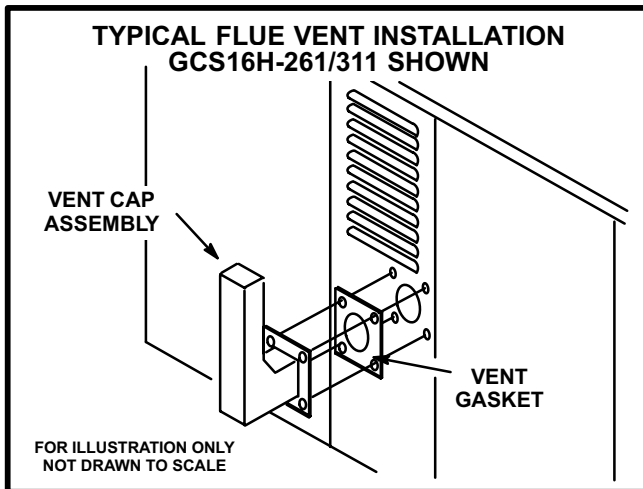

FIGURE 15

10-Burner Access Wind and Rain Shield (Figure 16)

WARNING - THE BURNER ACCESS PANEL WIND AND RAIN SHIELD MUST BE INSTALLED WITHOUT MODIFICATION. IF EITHER THE BURNER ACCESS PANEL OR WIND AND RAIN SHIELD IS NOT INSTALLED OR IS MODIFIED, IMPROPER UNIT OPERATION CAN RESULT AND AGA/CGA CERTIFICATION OF UNIT WILL BE VOID.

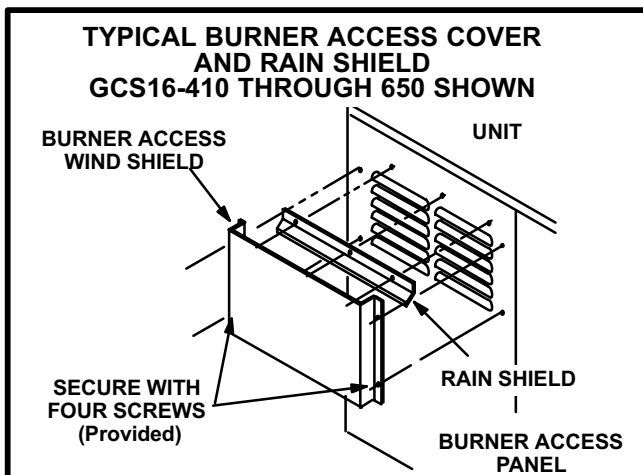

FIGURE 16

11-Combustion Air Blower Capacitor C3

All units equipped with 125K Btuh heat exchanger use a single-phase PSC motor to power the combustion air blower. A single run capacitor is mounted on the motor. The capacitor is rated 4mfd at 370VAC.

All other heat exchanger sizes use a shaded pole motor to power the combustion air blower. Shaded pole motors do not require a run capacitor.

12-Gas Valve GV1

Gas valve GV1 is a single-stage redundant valve manufactured by Honeywell. In 50,000 and 75,000 Btuh heat exchangers, the valve is slow opening (1-10 seconds). 100,000 and 125,000 Btuh heat exchangers use quick opening gas valves (1 sec. or less). On a call for heat, the valve is energized by the ignition control simultaneously with the spark electrode. When the valve is de-energized, it closes in 1/2 to 3 seconds. A manual shut-off knob is provided on the valve for shut-off. Figure 17 shows gas valve components. Table 5 shows factory gas valve regulation for GCS16 series units.

TABLE 5

Unit Input K Btuh	Maximum Inlet Pressure in. W.C.	Operating Pressure (outlet) in. W.C.	
		Natural	L.P.
50	21.0	3.5 +0 -0.3	10.5
75	21.0	3.5 +0 -0.3	10.5
100	21.0	3.5 +0 -0.3	9.5
125	21.0	2.7 +0 -0.3	10.0

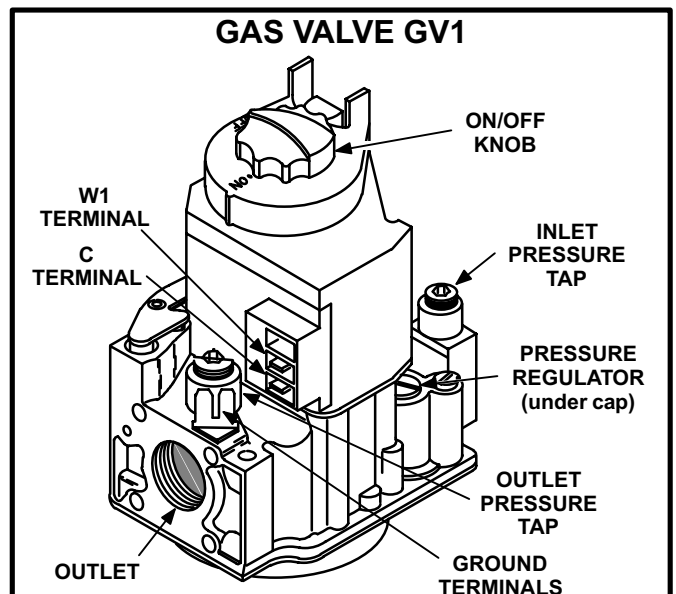

FIGURE 17

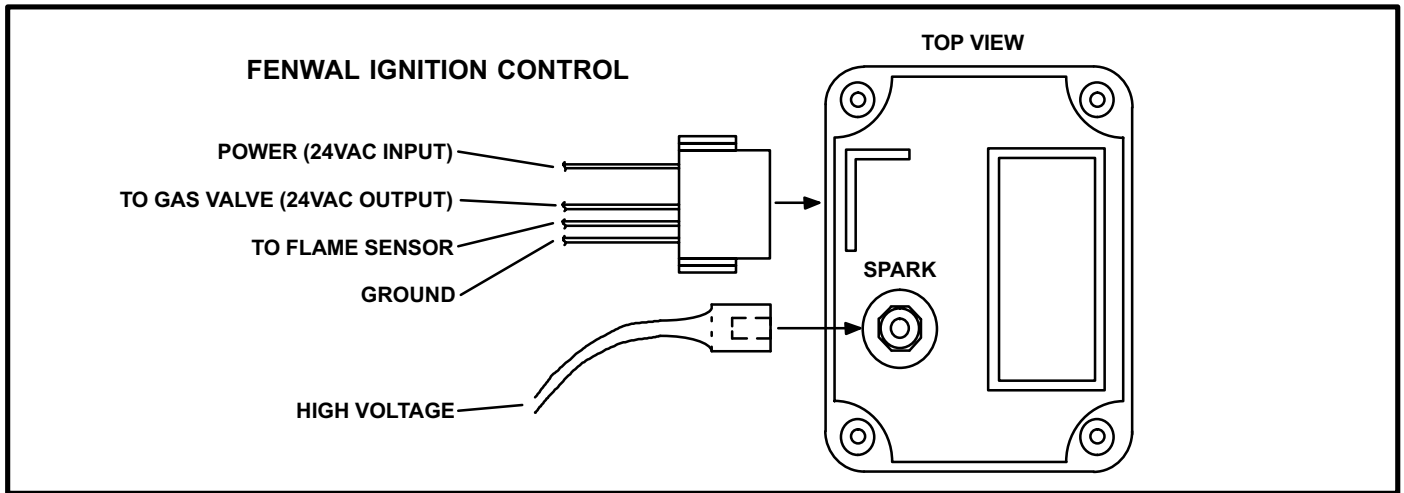

FIGURE 18

13-Electrode Assembly

The spark electrode/flame sensor assembly fits through a hole in the burner plate. The electrode tips are located in the path of the burner flame between the burner head and the flame spreader. The electrode assembly is fastened to the burner plate and can be removed for service without removing any part of the burner assembly (except in units with burner enclosure.)

During ignition spark travels through the spark electrode and arcs across to the ground electrode. During operation, flame is sensed by a current passed along the ground electrode, through the flame and into the sensing electrode.

a-Spark Electrode

The spark electrode is connected to the ignition control by a 5mm silicone insulated stranded high voltage wire. The wire uses 1/4" female quick connect on the electrode end and female spark plug-type terminal on the ignition control end.

NOTE - IN ORDER TO MAXIMIZE SPARK ENERGY TO THE ELECTRODE, THE HIGH VOLTAGE WIRE SHOULD NOT REST ON THE BOTTOM OF UNIT VESTIBULE PANEL AND SHOULD TOUCH UNIT CABINET AS LITTLE AS POSSIBLE.

b-Flame Sensor

Flame is sensed by rectification through the flame sensing electrode.

14-Ignition Control A3

In GCS16H units, ignition control A3 is located in the unit control box. In GCS16R and GCS16 units, ignition control A3 is located in the heating compartment. On a heating demand, the ignition control is energized after proving

combustion air blower operation. The control allows 30 to 40 seconds for the combustion air blower to vent exhaust gases from the burner. The ignition control then activates gas valve GV1, the spark electrode, the flame sensing electrode and blower delay relay K25. The ignition control is not adjustable.

WARNING - SHOCK HAZARD. SPARK RELATED COMPONENTS CONTAIN HIGH VOLTAGE WHICH CAN CAUSE PERSONAL INJURY OR DEATH. DISCONNECT POWER BEFORE SERVICING. CONTROL IS NOT FIELD REPAIRABLE. UNSAFE OPERATION WILL RESULT. IF THE CONTROL IS INOPERABLE, SIMPLY REPLACE THE ENTIRE CONTROL.

- a- An electronic direct spark ignition with flame rectification sensing is used on all GCS16 units. Flame signal strength ranges from 8 to 20 micro-amps. All units have controls manufactured by Fenwal.
- b- The Fenwal control is illustrated in figure 18. The four-wire harness, plugged directly into a jack on the side of the control, is used to connect the control to the unit. Each of the four jack terminals is identified by function. The spark electrode wire connects to the spark plug-type connector on top of the control.
- c- The ignition control provides three main functions: gas valve control, ignition and flame sensing. It is powered only after the combustion air prove switch has closed. The ignition attempt sequence provides three trials for ignition before locking out. The blower control (K25) is energized simultaneously with the gas valve, so the blower will energize 30 to 45 seconds after flame has successfully been established. The unit will usually ignite on the first attempt. See figure 19 for a normal ignition sequence with nominal timings for simplicity.

d- Proper gas/air mixture is required for ignition on the first attempt. If there is any deviation, within tolerance of the unit, a second or third trial may be necessary for ignition. The control will lock out the heating system if ignition is not obtained within three trials and the (indoor) blower will not start. Reset after lockout requires only breaking and re-making thermostat demand. See figure 20 for the

ignition attempt sequence with retrials (minimal timings given for simplicity). Loss of flame during a heating cycle is indicated by an absence of flame signal. If this happens, the control will immediately restart the ignition sequence and then lock out if ignition is not gained within three trials.

e- The specific timings for the Fenwal ignition control are shown in figure 21.

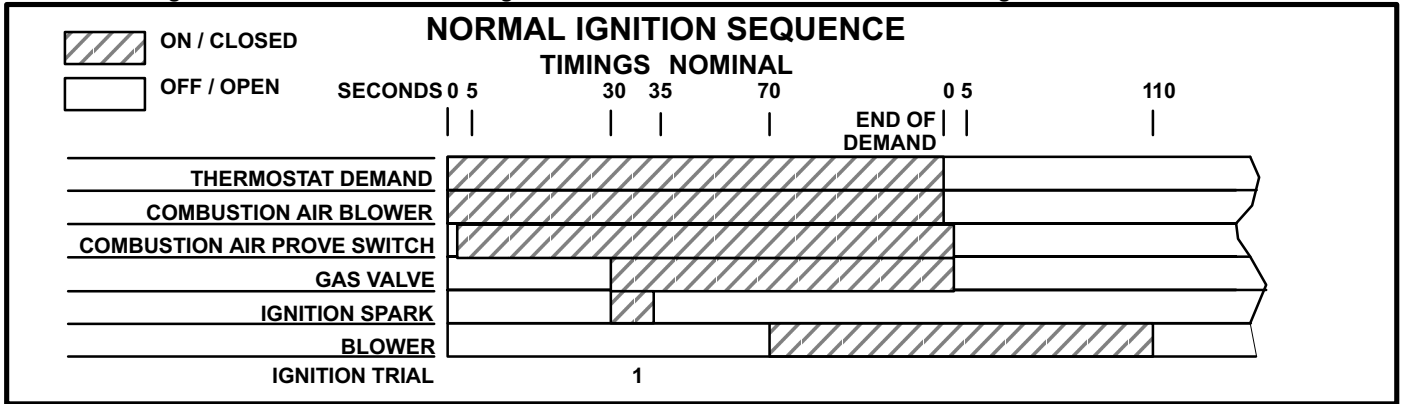

FIGURE 19

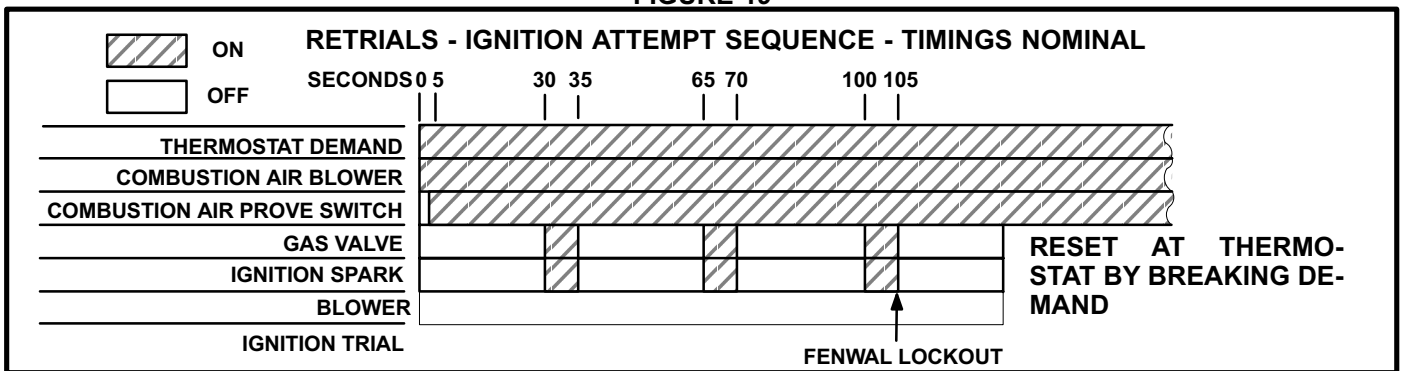

FIGURE 20

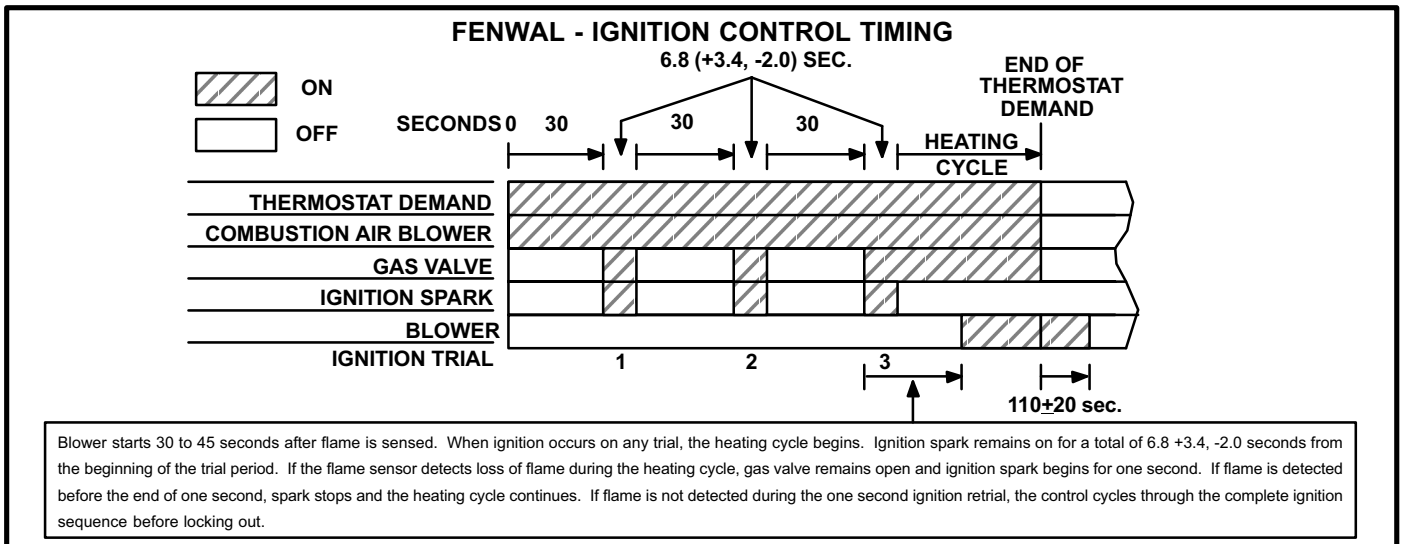

FIGURE 21

C-Cooling Components

Summary of Features

All units use DX cooling. Cooling in commercial units (GCS16) may also be supplemented by field-installed economizer. GCS16H-261/311, GCS16-411/413 and GCS16R-411 units use a single slab-type enhanced fin evaporator with rifled tubing and capillary, "cap," tubes as the primary expansion device (figure 22).

GCS16R-511/651 and GCS16-511/513/651/653 units use a single slab-type enhanced fin evaporator with rifled tubing and a thermal expansion valve "TXV" as the primary expansion device (figure 23). GCS16R and GCS16H series units are not equipped with crankcase heater, high pressure switch or loss of charge switch. All units are equipped with thermometer well for charging. All models use draw-through-type condenser fans.

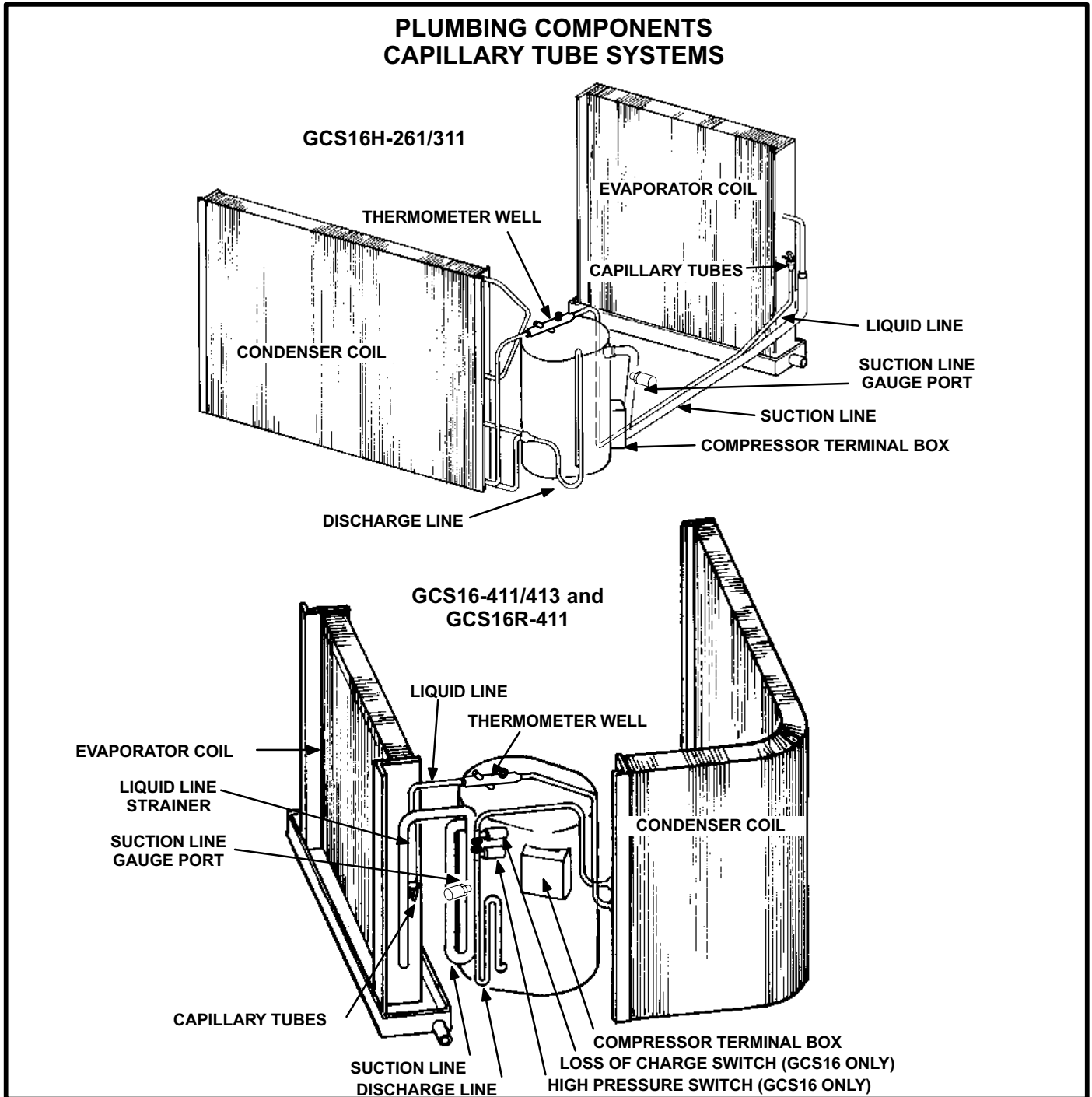

PLUMBING COMPONENTS THERMAL EXPANSION VALVE SYSTEMS

HIGH PRESSURE AND LOSS OF CHARGE SWITCHES USED ON GCS16 UNITS ONLY.

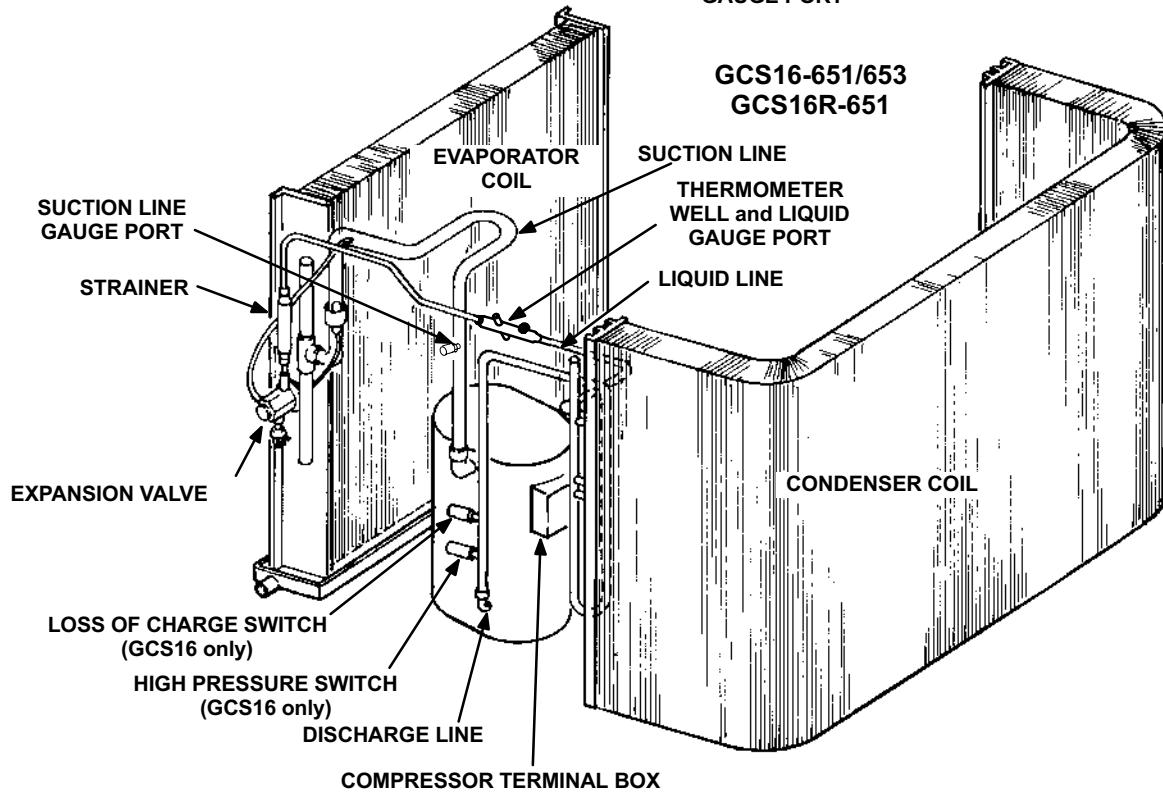
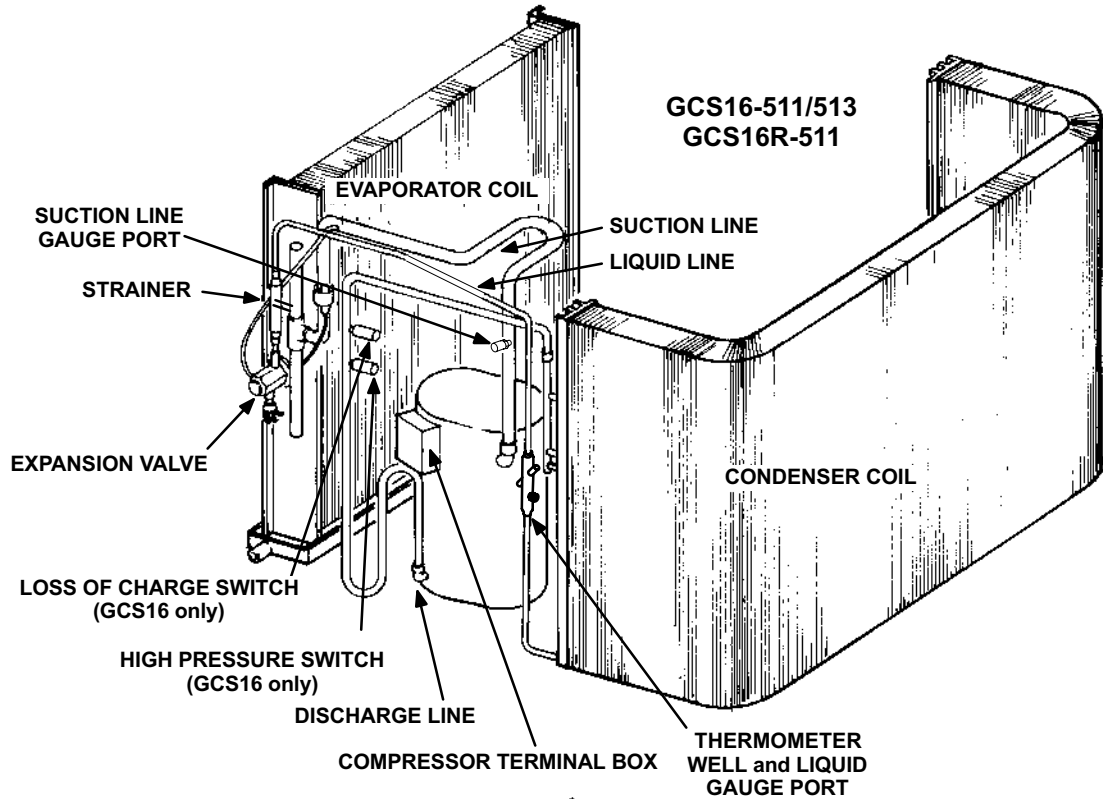

FIGURE 23

TABLE 6

GCS16 SERIES UNITS - COMPRESSOR SPECIFICATIONS							
Unit	Voltage/Phase	Locked Rotor Amps	Rated Load Amps	Oil Charge Fl. Oz.	Viscosity	Oil Type	Crankcase Heater
GCS16H-261	208/230/1	57.0	12.0	40	†	†	None
GCS16H-311	208/230/1	77.5	13.5	40			
GCS16R-411	208/230/1	83.5	17.6	55	190-210	**	40 watt Insertion Type Self Regulating
GCS16-411	208/230/1	83.5	17.6	55			
GCS16-413	208/230/1	66.0	11.5	55			
GCS16-413	460/3	35.0	5.3	55			
GCS16R-511	208/230/1	118.0	23.5	55	†	†	None
GCS16-511	208/230/1	118.0	23.5	55			
GCS16-513	208/230/3	90.0	15.4	55			
GCS16-513	460/3	45.0	8.4	55			
GCS16-513	575/3	36.0	6.4	50			
GCS16R-651	208/230/1	135.0	27.6	70			
GCS16-651	208/230/1	135.0	27.6	70	†	†	30 watt Insertion Type Self Regulating
GCS16-653	208/230/3	105.0	17.6	70			
GCS16-653	460/3	55.0	9.4	70			
GCS16-653	575/3	45.0	8.4	70			
					190-210	**	

*Texaco Capella WF-32 or Suniso 3GS or White Oil M/M Sontex 200-LT

**Heat Pump Grade Mineral

†Not Specified

1-Compressor B1

Table 6 shows the specifications of compressors used in all units. Compressors used in GCS16 commercial units are equipped with insertion type crankcase heaters. All compressors are protected by internal pressure relief valves and internal overload protection circuitry.

WARNING - COMPRESSOR MUST BE GROUNDED. DO NOT OPERATE WITHOUT PROTECTIVE COVER OVER TERMINALS. DISCONNECT POWER BEFORE REMOVING PROTECTIVE COVER. DISCHARGE CAPACITORS BEFORE SERVICING UNIT. FAILURE TO FOLLOW THESE PRECAUTIONS COULD CAUSE ELECTRICAL SHOCK RESULTING IN INJURY OR DEATH.

2-High Pressure Limit S4

The high pressure limit is a manually reset SPST N.C. switch which opens on a pressure rise. All commercial units (GCS16) are equipped with the limit. GCS16R and GCS16H are not equipped with the limit. The switch is located in the compressor discharge line and is wired in series with the compressor contactor. When discharge pressure rises above 410±10 psig (indicating a problem in the system) the switch opens and the compressor is de-energized (the economizer can continue to operate.) After the problem has been found and corrected, the switch can be reset by pushing-in the switch button.

3-Loss of Charge Switch S24

The loss of charge switch is an auto-reset SPST N.C. switch which opens on a pressure drop. All commercial units (GCS16) are equipped with the switch. GCS16R and GCS16H are not equipped with the switch. The switch is located in the compressor discharge line and is wired in series with the high pressure switch and compressor contactor. When discharge pressure drops below 25±5 psig (indicating a loss of charge in the system) the switch opens and the compressor is de-energized. The switch automatically resets when refrigerant is added and pressure in the discharge line rises above 55±5 psig.

4-Start Capacitor C7

All single-phase units (size -511 and larger) use a compressor start capacitor (C7) connected in parallel with the run capacitor (C5). The capacitor is energized during compressor startup and is switched off by potential relay K31 when the compressor nears full speed. Three-phase units do not use start capacitors. Table 7 shows start capacitor ratings for single-phase GCS16s. The capacitor is mounted in the unit control box. See figure 6 for capacitor location.

The start capacitor uses a 15K ohm 2 watt “bleed” resistor connected in parallel with the capacitor terminals. The resistor is used to slowly discharge the capacitor when not in use.

TABLE 7

COMPRESSOR START CAPACITOR	
Unit	MFD @ Volts
GCS16H-261	Not Used
GCS16H-311	Not Used
GCS16R-411	Not Used
GCS16-411	Not Used
GCS16R-511	135 to 155 @ 320 VAC
GCS16-511	135 to 155 @ 320 VAC
GCS16R-651	176 to 216 @ 320 VAC
GCS16-651	176 to 216 @ 320 VAC

5-Compressor Run Capacitor C5

All single-phase units use compressor run capacitors to maximize compressor efficiency. Table 8 shows run capacitors used in GCS16 single-phase units. Three-phase units do not use run capacitors. See figure 3 for capacitor location.

TABLE 8

COMPRESSOR RUN CAPACITOR		
Unit	Type	MFD @ Volts
GCS16H-261	Single	30 @ 370
GCS16H-311	Single	35 @ 370
GCS16-411 GCS16R-411	Dual (shared with condenser fan)	40 @ 370
GCS16R-511 GCS16-511	Single	40 @ 440
GCS16R-651 GCS16-651	Single	45 @ 440

6-Condenser Coil

All GCS16s have a single condenser coil. Each coil has two rows (GCS16-511/513 and GCS16R-511 have 1-1/2 rows) of copper tubes fitted with ripple-edged aluminum enhanced fins.

7-Condenser Fan and Motor B4

The specifications table on page 1 in this manual shows the specifications of condenser fans used in GCS16s. The condenser fan in all units is controlled by cooling contactor K1.

8-Condenser Fan Motor Capacitor C1

All GCS16s use single-phase PSC condenser fan motors. Table 9 shows fan run capacitor ratings for GCS16s.

TABLE 9

CONDENSER FAN MOTOR CAPACITOR				
Unit & Unit Voltage		Type	MFD @ Volts	
GCS16H-261	208/230	Single	7	370
GCS16H-311	208/230	Single	7	370
GCS16-411 GCS16R-411	208/230	Dual (shared with compressor)	5	370
GCS16-413	ALL	Single	5	370
GCS16-511/651 GCS16R-511/651	208/230	Single	7	370
GCS16-513/653	ALL	Single	7	370

9-Blower Motor B3

All GCS16 series units use single-phase PSC blower motors. A single run capacitor is mounted on the blower housing. All motors use multiple speed taps. Typically, the high speed tap is energized during compressor operation and a lower speed tap is energized during heating operation.

Blower motors in GCS16 -261, -311 and -411 units have four speed taps. Motors in GCS16 -511 and -651 units have five speed taps. All G (460V) and J (575V) voltage units have three taps. Blower motor specifications are listed in table 10. Blower specifications are listed in the tables on pages 1 and 2.

A third (blue) tap on G (460V) and J (575V) volt motors is used to complete an internal circuit during low or medium speed operation. It must never be connected to line voltage. During low speed (red tap) operation, the high speed (black) tap is disconnected from line voltage and is connected to blue internal wiring tap (see figure 24). Internal wiring is shown in figure 25.

TABLE 10

BLOWER MOTOR - 825 RPM - CCW ROTATION				
Unit	Motor Volts	Phase	HP	FLA
GCS16H-261	208/230	1	1/3	2.2
GCS16H-311	208/230	1	1/3	2.2
GCS16-411/413 GCS16R-411	208/230	1	1/2	3.9
GCS16-413	460	1	1/2	1.8
GCS16-511/513 GCS16R-511	208/230	1	3/4	4.6
GCS16-513	460	1	3/4	1.8
GCS16-513	575	1	3/4	0.7
GCS16-651/653 GCS16R-651	208/230	1	3/4	4.6
GCS16-653	460	1	3/4	1.8
GCS16-653	575	1	3/4	0.7

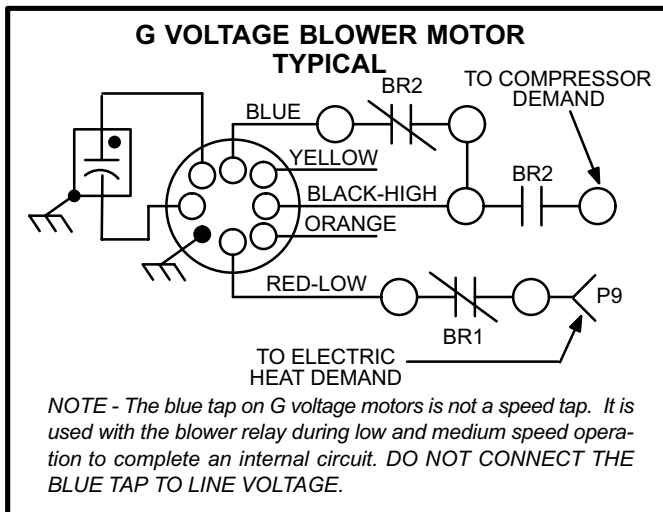

FIGURE 24

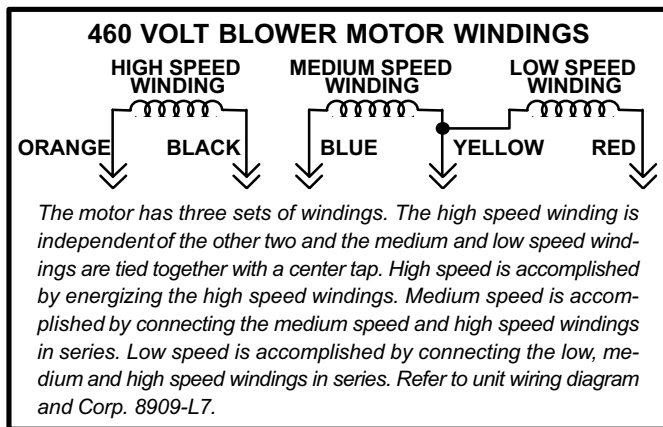

FIGURE 25

WARNING - DO NOT ISOLATE MEDIUM OR LOW SPEED WINDINGS WHEN OPERATING AT MEDIUM OR LOW SPEED. THE BLUE LEAD MUST NEVER BE CONNECTED TO A POWER LEAD (BLOWER DEMAND FROM HEAT RELAY OR BLOWER RELAY) OR TO COMMON. FAILURE TO CONNECT THE BLUE TAP AS SHOWN ON UNIT DIAGRAM WILL CAUSE IMPROPER OPERATION, INCREASED CURRENT FLOW AND/OR BURNT WINDINGS.

10-Indoor Blower Motor Capacitor C4

All GCS16 208/230v units use single-phase PSC motors. The run capacitor is mounted on the blower housing. Capacitor ratings are shown in table 11.

460v and 575v units use three-phase 460v blower motors. Run capacitor is not required.

TABLE 11

Unit 208/230v	Blower Capacitor Rating
GCS16H-261/-311	7 MFD at 370 V
GCS16-411/-413 GCS16R-411	10 MFD at 370 V
GCS16-511/-513 GCS16R-411	20 MFD at 370 V
GCS16-651/-653 GCS16R-411	20 MFD at 370 V

11-Evaporator Coil

All GCS16s have a single slab evaporator coil. The coil has two rows of rifled copper tubes fitted with ripple-edged aluminum fins. An expansion device feeds multiple parallel circuits through the coil.

a-Capillary Tubes

GCS16H-261, GCS16H-311, GCS16-411/413 and GCS16R-411 units use capillary tubes as the primary expansion device. Each tube feeds an independent parallel circuit through the coil. See figure 26.

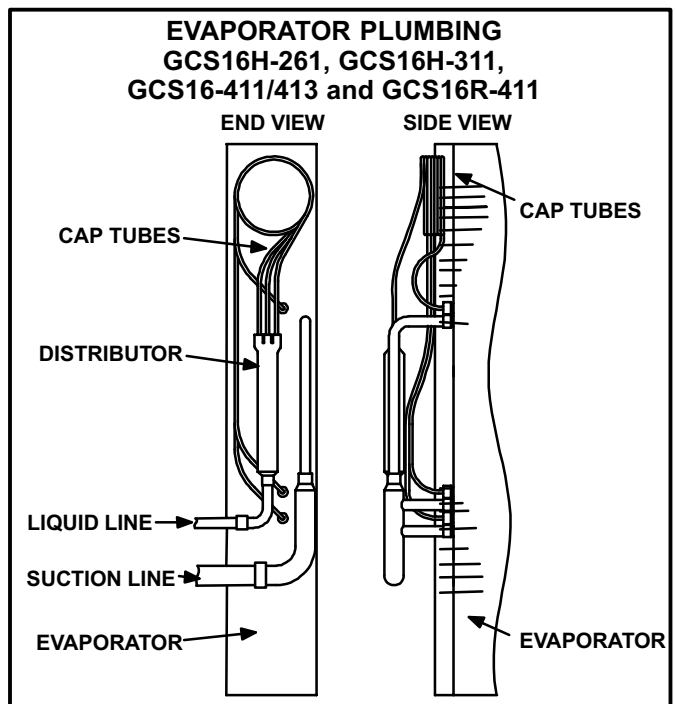

FIGURE 26

b-Expansion Valve

GCS16 -510 through -650 series units use a Thermal Expansion Valve (TXV) as the primary expansion device. See figure 27.

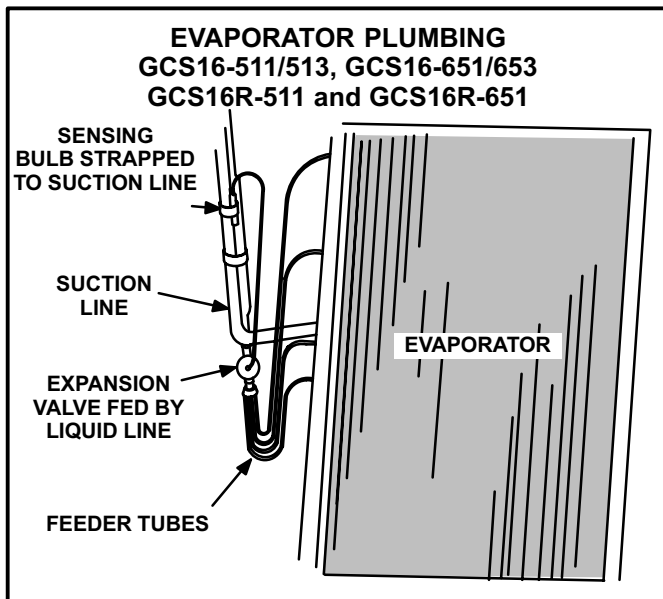

FIGURE 27

12-Thermometer Well (Figure 28)

All units are factory equipped with a thermometer well for charging the unit. The well is used to accurately measure the temperature of the liquid line. The temperature measured is then used to calculate the approach or subcooling temperature. Approach and subcooling temperatures are compared to tables printed in the charging section of this manual to determine the correct charge. The thermometer wells are equipped with a gauge port for connection of high pressure gauge.

To accurately measure the temperature of the liquid line, the well should be filled with a light mineral oil before using. This will ensure good heat transfer to the thermometer.

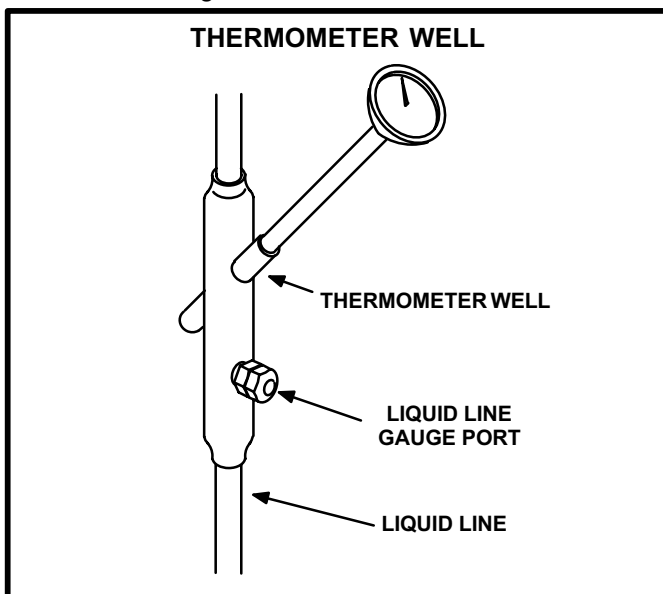

FIGURE 28

III-PLACEMENT AND INSTALLATION

Make sure that the unit is installed in accordance with the installation instructions and all applicable codes. See accessories section for conditions requiring use of the optional roof mounting frame (RMF16).

IV-ELECTRICAL CONNECTIONS

A-Power Supply

Refer to start-up directions and refer closely to the unit wiring diagram when servicing. Refer to unit nameplate for minimum circuit ampacity and maximum fuse size. 208/460/575 volt units are factory wired with red wire connected to control transformer primary. 230 volt units are field wired with orange wire connected to control transformer primary.

DANGER - ALL SINGLE-PHASE UNITS USE SINGLE-POLE CONTACTORS. COMPRESSOR (TERMINAL R), ONE LEG OF THE START AND RUN CAPACITORS AND ONE LEG OF THE CONDENSER FAN ARE POWERED AT ALL TIMES. MAKE SURE POWER IS TURNED OFF AT DISCONNECT BEFORE SERVICING UNIT.

V-START-UP - OPERATION

A-Preliminary Checks

- 1- Make sure that the unit is installed in accordance with the installation instructions and applicable codes.
- 2- Inspect all electrical wiring, both field and factory installed for loose connections. Tighten as required.
- 3- Check to ensure that refrigerant lines are in good condition and do not rub against the cabinet or other refrigerant lines.
- 4- Check voltage at the disconnect switch. Voltage must be within the range listed on the nameplate. If not, consult the power company and have the voltage condition corrected before starting the unit.
- 5- Recheck voltage with unit running. If power is not within range listed on unit nameplate, stop unit and consult power company. Check amperage of unit. Refer to unit nameplate for correct running amps.

B-Cooling Start-Up

NOTE - The following is a generalized procedure and does not apply to all thermostat control systems. Electronic and ramping thermostat control systems may operate differently. Refer to the operation sequence section of this manual for more information.

- 1- Set fan switch to AUTO or ON and move the system selection switch to COOL. Adjust the thermostat to a setting far enough below room temperature to bring on the compressor.
- 2- Close unit disconnect switch. Compressor will start and cycle with demand.
- 3- The refrigerant circuit is charged with HCFC-22 refrigerant. See unit rating plate for correct amount of charge.
- 4- Refer to the Refrigeration System Service Checks section for the proper method to check refrigerant charge.

C-Heating Start-Up:

CAUTION - This unit is equipped with a direct spark ignition system. Do not attempt to light manually.

- 1- Set thermostat to OFF position. Close manual knob on gas valve.
- 2- Wait 5 minutes.
- 3- Open manual knob on gas valve, replace burner access door and turn on unit electrical supply.
- 4- Set the fan switch to AUTO or ON and move the system selection switch to HEAT. Adjust the thermostat setting above room temperature.
- 5- The combustion air blower immediately starts. The burner lights within 40 sec.
- 6- If the unit does not light the first time, it will attempt up to two more times before locking out.
- 7- If lockout occurs, repeat steps 1, 2, 3 and 4.

D-Safety or Emergency Shutdown:

Turn off power to the unit. Close the manual and/or main gas valves.

E-Extended Period Shutdown:

Turn off the thermostat or set to "UNOCCUPIED" mode. Close all gas valves both internal and external to the unit to prevent gas leakage into the combustion chamber. Turn off power to the unit. All access panels, covers and vent caps must be in place and secured.

VI-REFRIGERATION SYSTEM SERVICE CHECKS

The charge should be checked during start-up using the method outlined below.

A-Gauge Manifold Attachment

Service gauge ports are identified in figures 22 and 23. Attach gauge manifold high pressure line to liquid line gauge port on thermometer well. Attach gauge manifold low pressure line to suction line service port.

NOTE - When unit is properly charged (whether by approach or subcooling method) liquid line pressures should approximate those given in table 13.

B-Charging

It is not recommended that the system be charged below 60°F (15°C). If charging below 60°F is required or if the system is completely void of refrigerant, the recommended and most accurate method of charging is to weigh the refrigerant into the unit according to the amount shown on the unit nameplate and in the specifications table. If weighing facilities are not available or if the unit is just low on charge, use the following procedures:

Unit Void of Refrigerant

- 1- Connect an upright HCFC-22 drum to the center port of gauge manifold. Purge air from connecting line.
- 2- Start unit.
- 3- Open drum valve and charge a quantity of refrigerant gas into the system through the compressor suction port, then close refrigerant drum valve. Allow unit to run for a few minutes to stabilize operating pressure. Determine correct charge as follows.

CHECKING CHARGE ALL UNITS

- 1- This method uses a thermometer inserted in the thermometer well to check liquid line temperature. *Make sure thermometer well is filled with oil before checking.*
- 2- Allow unit to run for at least five minutes to stabilize pressures.

**GCS16H-261/311, GCS16-411/413
and GCS16R-411 ONLY
(GCS16-510/650 skip to step 6)
(Subcooling Method)**

- 3- If ambient temperature is above 60°F (15°C), place thermometer in well and read temperature.

- 4- Read liquid line pressure from gauge and convert to condensing temperature using standard HCFC-22 temperature/pressure conversion chart (or conversion scale on gauge).
- 5- The difference between the liquid line temperature (from step 3) and the conversion temperature (from step 4) is subcooling (subcooling = conversion temperature minus liquid temperature). Subcooling temperature should approximate the values given in table 12. Add refrigerant to increase subcooling and remove refrigerant to reduce subcooling.

TABLE 12

MODEL NO.	Subcooling °F at Various Ambient Temps.					
	65°F	75°F	85°F	95°F	105°F	115°F
GCS16H-261	14	14	14	14	12	8
GCS16H-311	17	17	16	15	12	9
GCS16R-411	18	18	16	14	12	8
GCS16-411	18	18	16	14	12	8

GCS16-511/513

GCS16-651/653

GCS16R-511 and GCS16R-651 ONLY

(Approach Method)

- 6- Check ambient (outdoor) temperature.

- 7- If ambient temperature is above 60°F (15°C), place thermometer in well and read temperature.
- 8- Approach temperature is the difference between ambient and liquid line temperatures (Approach = liquid minus ambient.) Approach temperature should be 4°F (2°C) for GCS16-511/513 and GCS16R-511 units. Approach temperature should be 9°F (5°C) for GCS16-651/653 and GCS16R-651 units. Refrigerant must be added to lower approach temperature. Remove refrigerant from system to increase approach temperature.

NOTE - Use table 13 as a general guide for performing maintenance checks. When unit is properly charged (whether by approach or subcooling method) line pressures should approximate those given in table 13. Table 13 is not a procedure for charging the system. Minor variations in these pressures may be expected due to differences in installations. Significant deviations could mean that the system is not properly charged or that a problem exists with some component in the system. Used prudently, table 13 could serve as a useful service guide.

**TABLE 13
NORMAL OPERATING PRESSURES**

MODEL NO.	65 °F		75 °F		85 °F		95 °F		105 °F		115 °F	
	LIQ. ± 10 PSIG	SUC. ± 5 PSIG	LIQ. ± 10 PSIG	SUC. ± 5 PSIG	LIQ. ± 10 PSIG	SUC. ± 5 PSIG	LIQ. ± 10 PSIG	SUC. ± 5 PSIG	LIQ. ± 10 PSIG	SUC. ± 5 PSIG	LIQ. ± 10 PSIG	SUC. ± 5 PSIG
GCS16H-261	149	55	182	66	216	73	246	78	282	84	318	89
GCS16H-311	154	64	188	69	223	74	256	77	292	83	326	87
GCS16-411/413 GCS16R-411	146	57	182	66	214	73	252	78	287	83	328	87
GCS16-511/513 GCS16R-511	158	58	190	68	222	76	255	79	290	82	330	84
GCS16-651/653 GCS16R-651	146	55	178	66	210	73	244	76	289	78	335	80

VII-HEATING SYSTEM SERVICE CHECKS

A-A.G.A./C.G.A. Applications and Requirements

All GCS16s are A.G.A and C.G.A. design certified without modification.

Refer to the GCS16 Operation and Installation Instruction Manual for more information.

B-Gas Piping

Gas supply piping must not allow more than 0.5"W.C. drop in pressure between the gas meter and the unit. Supply gas pipe must not be smaller than the unit gas connection.

Compounds used on threaded joints of gas piping should be resistant to the action of liquefied petroleum gas.

C-Testing Gas Piping Pressure

NOTE - In case emergency shutdown is required, turn off the main manual shut-off valve and disconnect the main power to the unit. These controls should be properly labeled by the installer.

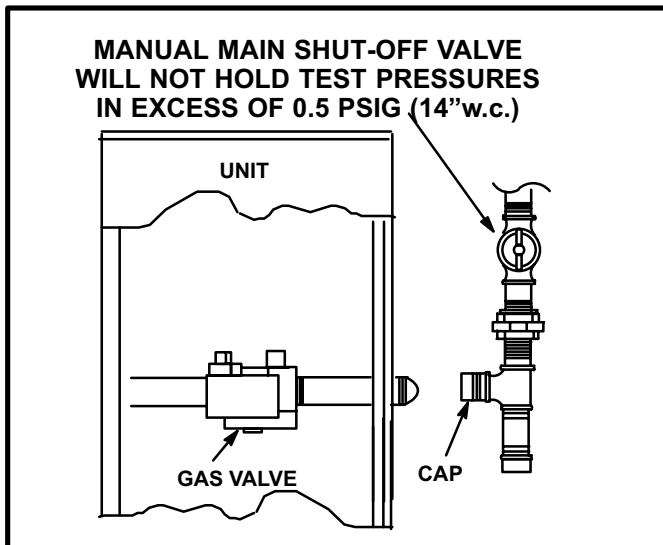

FIGURE 29

When pressure testing gas lines, the gas valve must be disconnected and isolated. Gas valves can be damaged if subjected to more than 0.5 psig (14"W.C.). See Figure 29.

If the test pressure is equal to or less than 0.5 psig (14"W.C.), use the main manual shut-off valve before pressure testing to isolate the unit from the gas supply system.

When checking piping connection for gas leaks, use a soap solution or other preferred means. Do not use matches, candles, flame, or other source of ignition to check for gas leaks.

D-Testing Gas Supply Pressure

When testing gas supply pressure, connect test gauge to the inlet pressure tap (field provided). Test supply gas pressure with unit firing at maximum rate. Make sure the reading falls within the range of the following values. Low pressure may result in erratic operation or "underfire." High pressure can result in permanent damage to the gas valve or "overfire." For natural gas units, operating pressure at the unit gas connection must be between 4.5"W.C. and 13.5"W.C. For L.P. gas units, operating pressure at the unit gas connection must be between 11"W.C. and 13.5"W.C.

On multiple unit installations, each unit should be checked separately, with and without the other units operating. Supply pressure must fall within the range listed in the previous paragraph.

E-Check and Adjust Manifold Pressure

After line pressure has been checked and adjusted, check manifold pressure. Refer to figure 30 for location of manifold pressure adjustment screw. See figure 17 for location of pressure tap on the gas valve.

The gas valve is factory set and should not require adjustment. All gas valves are factory regulated as shown in table 14. The gas valve should completely and immediately cycle off in the event of gas or power failure. The manual shut-off knob can be used to immediately shut off gas supply.

TABLE 14

Unit Input K Btuh	Maximum Inlet Pressure in. W.C.	Operating Pressure (outlet) in. W.C.	
		Natural	L.P.
		50	21.0
75	21.0	3.5 +0 -0.3	10.5
100	21.0	3.5 +0 -0.3	9.5
125	21.0	2.7 +0 -0.3	10.0

CAUTION-For safety, connect a shut-off valve between the manometer and the gas tap to permit shut off of gas pressure to the manometer.

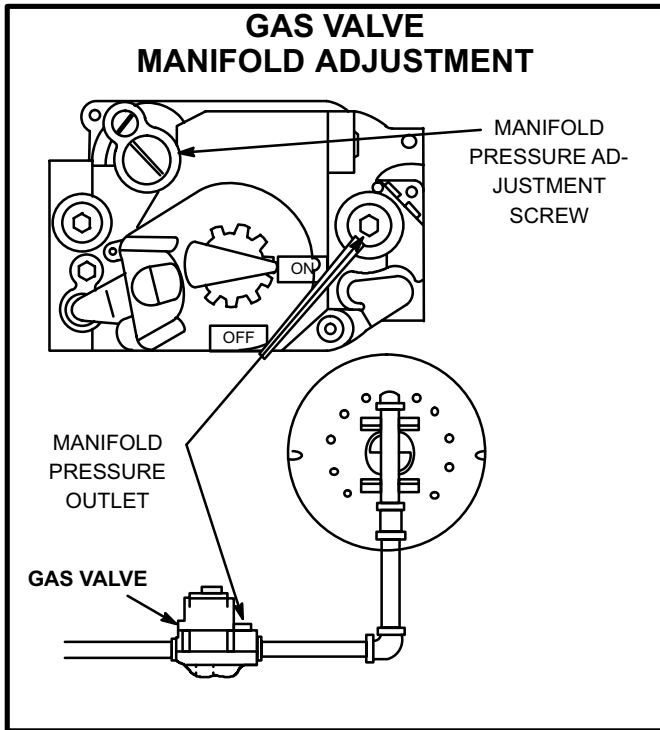

FIGURE 30

- 1- Connect a test gauge to the outlet pressure tap on the gas valve. Start the unit and allow five minutes for the unit to reach steady state.
- 2- While waiting for the unit to stabilize, notice the flame. The flame should be stable without flashback and should not lift from the burner head. Natural gas should burn blue. L.P. gas should burn mostly blue with some orange streaks.
- 3- After allowing the unit to stabilize for five minutes, record the manifold pressure and compare to the values given in table 14.

CAUTION-Disconnect heating demand as soon as an accurate reading has been obtained.

F-Proper Gas Flow

To check for proper gas flow to combustion chamber, determine Btuh input from the unit rating plate or table 15. Divide this input rating by the Btuh per cubic foot of available gas. Result is the number of cubic feet per hour required. Determine the flow of gas through gas meter for two minutes and multiply by 30 to get the hourly flow of gas to the burner.

TABLE 15

Unit	Unit Input	Unit Output	Input (cubic feet)
GCS16(H)-50	50,000 Btuh	40,000 Btuh	
GCS16-75	75,000 Btuh	60,000 Btuh	
GCS16-100	100,000 Btuh	80,000 Btuh	
GCS16-125	125,000 Btuh	100,000 Btuh	

G-High Altitude Derate

The maximum input may be reduced by up to 24 percent on A.G.A. units equipped with adjustable gas valves and operating on natural gas. See table 16.

Follow the derate instructions shown below. If high altitude conditions are present, also follow the instruction in table 16.

To reduce maximum input (derate instructions):

- 1- Check manifold pressure at the gas valve pressure tap.
- 2- To reduce maximum input, turn regulator adjusting screw (figure 17) counterclockwise.
- 3- Re-check manifold pressure.

TABLE 16

HIGH ALTITUDE DERATE	
If the heating value of the gas does not exceed the values listed in this table, derating of unit is not required. Should the heating value of the gas exceed the table values, or if the elevation is greater than 6,000 ft. above sea level, it will be necessary to derate the unit. Lennox requires that derate conditions be 4 percent per thousand feet above sea level. Thus at an altitude of 4000 feet, if the heating value of the gas exceeds 1000 Btu/cubic ft., the unit will require a 16 percent derate.	
Elevation Above Sea Level (Feet)	Maximum Heating Value (Btu/cubic ft.)
5001-6000	900
4001-5000	950
3001-4000	1000
2001-3000	1050
Sea Level - 2000	1100

H-Inshot Burner

When servicing the burner, do not remove the bolts behind slots in the burner plate (see figure 32).

Burner is factory set and does not require adjustment. End-cap (if used) cannot be adjusted. Always operate the unit with access panel in place. A peep hole with cover is furnished in the cabinet access panel for flame viewing. On units equipped with burner enclosure, a glass viewing port is also provided for viewing flame. The flame should be blue with minimum yellow streaking.

Figure 31 shows how to remove burner assembly.

- 1-Turn off power to unit and shut off gas supply.
- 2-Disconnect wires to rollout switch and gas valve.
- 3-Remove burner enclosure (if so equipped) by removing bolts securing enclosure to burner plate. To remove the assembly, first remove octagon backplate. Loosen nuts on top and bottom surfaces at overlap and remove four mounting bolts at burner plate.
- 4-Remove gas valve/manifold assembly by removing bolts securing assembly to vestibule. Manifold, valve and bracket will be removed as a unit. *NOTE - See figure 32 for CAUTION concerning burner plate removal.* First detach the gas manifold bracket. Next, remove the four screws securing the gas burner manifold to the burner plate. Take care not to damage ceramic cone in combustion chamber. If cone is damaged, it must be replaced.
- 5-Slide burner off orifice.
- 6-Clean as necessary and reassemble (reverse steps 1-5). Replace the four screws securing the gas/burner manifold to the burner plate. **(If burner enclosure was previously removed, it must be reassembled taking care not to create air leaks due to misalignment of parts which will adversely affect unit performance.)** Secure the gas manifold bracket and ensure proper burner head alignment. Bolts must be torqued to 35 in-lbs. to ensure proper operation.
- 7-Be sure to secure all wires and check plumbing and burner plate for airtight seal.
- 8-Turn on power to unit. Follow lighting instructions attached to unit and operate unit in heating mode. Check burner flame. It should be blue with clear yellow streaking.

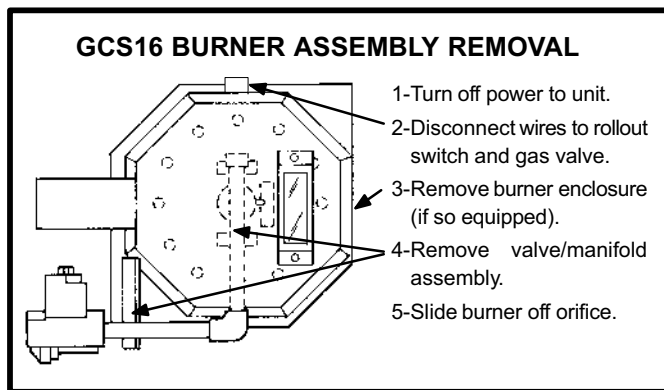

FIGURE 31

I-Burner Cone

When replacing the burner cone, the heat exchanger must be removed. To remove or replace the burner cone refer to the procedure for removing the heat exchanger in section "K-Heat Exchanger."

CAUTION - AFTER UNIT HAS BEEN OPERATED, BURNER CONE CAN BE EASILY DAMAGED BY HANDLING. IT MUST BE HANDLED CAREFULLY. CONE MUST BE REPLACED IF EITHER INSIDE OR OUTSIDE EDGE ARE DAMAGED. A DAMAGED INSIDE EDGE CAN CAUSE IMPROPER OPERATION. A DAMAGED OUTSIDE EDGE CAN CAUSE EXHAUST PRODUCTS TO ENTER LIVING SPACE. DO NOT ALLOW UNIT TO OPERATE WITH A DAMAGED BURNER CONE.

J-Burner Plate Gasket

The burner plate gasket needs to be inspected or replaced only when the burner plate or heat exchanger are removed. When replacing the burner plate gasket, the burner, gas valve and manifold assembly must be removed.

To Replace Burner Plate Gasket:

- 1-Turn off power to unit and shut off gas supply.
- 2-Disconnect rollout switch and gas valve wires.
- 3-Remove burner enclosure (if so equipped) by removing bolts securing enclosure to burner plate.
- 4-Remove gas valve/manifold assembly by removing bolts securing assembly to vestibule.
- 5-Remove burner plate by removing bolts securing burner plate to vestibule.

NOTE - See figure 32 regarding slots in burner plate.

- 6-Replace gasket and reassemble (reverse steps 1-5). Be sure to secure all wires and check plumbing and burner plate for airtight seal. Bolts must be torqued to 35 in-lbs. to ensure proper operation.
- 7-Turn on power to unit.

K-Heat Exchanger

WARNING - WHEN SERVICING THE BURNER, DO NOT REMOVE THE BOLTS IN THE BURNER PLATE SLOTS (SEE FIGURE 32). THESE BOLTS SUPPORT THE HEAT EXCHANGER CASTING. REMOVAL OF THESE BOLTS WILL ALLOW THE HEAT EXCHANGER TO DROP INSIDE THE CABINET AND COULD RESULT IN HEAT EXCHANGER DAMAGE.

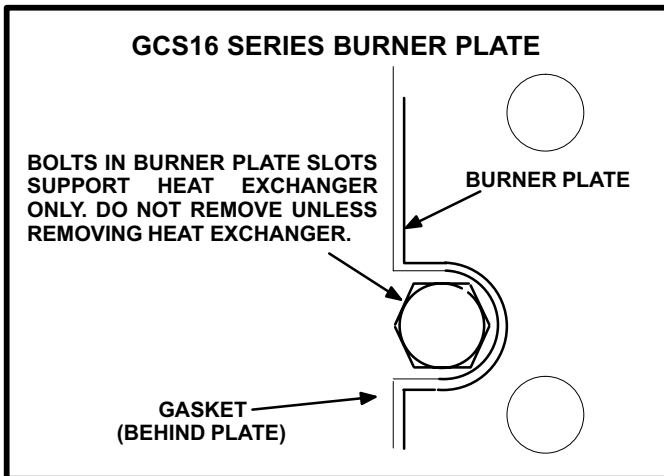

FIGURE 32

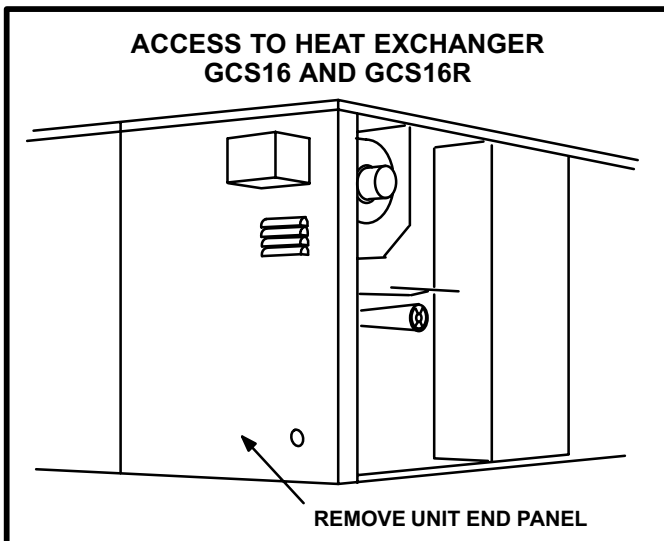

FIGURE 33

To Access or Remove Heat Exchanger From Unit:

- 1-Turn off gas and electric power.

- 2-Remove cabinet end panel (see figure 33).
- 3-Remove combustion air blower and flue box. Pay careful attention to the order in which gaskets and orifice are removed.
- 4-Remove bolt in back of casting (see figure 34).
- 5-Remove bolts supporting heat exchanger in burner plate (see figure 32).
- 6-Support heat exchanger (to prevent heat exchanger from dropping when final bolts are removed.) Remove bolts securing tailpipe to heating vestibule. Bolts are located behind flue box cover.
- 7-To install heat exchanger, reverse procedure. Burner cone should be replaced when heat exchanger is replaced. Be sure to secure all wires and check plumbing and burner plate for airtight seal. Bolts must be torqued to 35 in-lbs. to ensure proper operation.

CAUTION - AFTER UNIT HAS BEEN OPERATED, BURNER CONE CAN BE EASILY DAMAGED BY HANDLING. IT MUST BE HANDLED CAREFULLY. CONE MUST BE REPLACED IF EITHER INSIDE OR OUTSIDE EDGE ARE DAMAGED. A DAMAGED INSIDE EDGE CAN CAUSE IMPROPER OPERATION. A DAMAGED OUTSIDE EDGE CAN CAUSE EXHAUST PRODUCTS TO ENTER LIVING SPACE. DO NOT ALLOW UNIT TO OPERATE WITH A DAMAGED BURNER CONE.

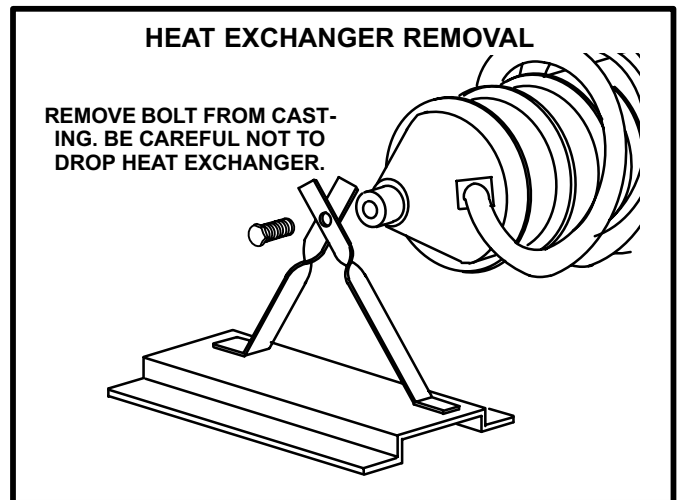

FIGURE 34

L-Ignition (Burner) Control A3

Ignition control A3 is factory set and is not adjustable. The control makes three attempts at ignition and then locks out the system if ignition is not obtained after the third trial. Reset after lockout requires only breaking and remaking thermostat demand. The control shuts off gas flow imme-

diately in the event of a gas or power failure. Upon restoration of gas and power, the control will restart the ignition sequence and continue until flame is established or system lockout occurs.

For proper unit operation, the electrodes must be positioned correctly in the flame and must be gapped correctly.

DANGER - SHOCK HAZARD. SPARK RELATED COMPONENTS CONTAIN HIGH VOLTAGE. DISCONNECT POWER BEFORE SERVICING.

WARNING - THE IGNITION CONTROL IS NOT FIELD REPAIRABLE. UNSAFE OPERATION WILL RESULT.

M-Spark Electrode/Flame Sensor/Spark Gap

DANGER - SHOCK HAZARD. SPARK RELATED COMPONENTS CONTAIN HIGH VOLTAGE. DISCONNECT POWER BEFORE SERVICING.

The electrode assembly can be removed for inspection by removing two screws securing the electrode assembly and sliding it out of unit.

Spark gap may be checked with appropriately sized twist drills or feeler gauges. Disconnect power to the unit and remove electrode assembly. The gap should be between 0.094" and 0.156". See figure 35.

DANGER - ELECTRODES ARE NOT FIELD ADJUSTABLE. ANY ALTERATIONS TO THE ELECTRODE MAY CREATE A HAZARDOUS CONDITION THAT CAN CAUSE PROPERTY DAMAGE OR PERSONAL INJURY.

N-Flame Sensing

Flame current is an electrical current which passes from the ignition control through the sensor electrode during unit operation. The current passes from the sensor through the flame to ground electrode to complete a safety circuit. The minimum flame current necessary to keep the ignitor from lockout is 5 microamps. The electrodes should be located so the tips are at least 1/2" inside the flame envelope. Do not bend electrodes. To measure flame current, follow the procedure below:

- 1-Disconnect power to unit.
- 2-Remove lead from sensing electrode and install a 0-50DC microamp meter in series between the sensing electrode and the sensing lead.
- 3-Reconnect power and adjust thermostat for heating demand.
- 4-When flame is established, meter reading should be 8 to 20 microamps. Do not bend electrodes.

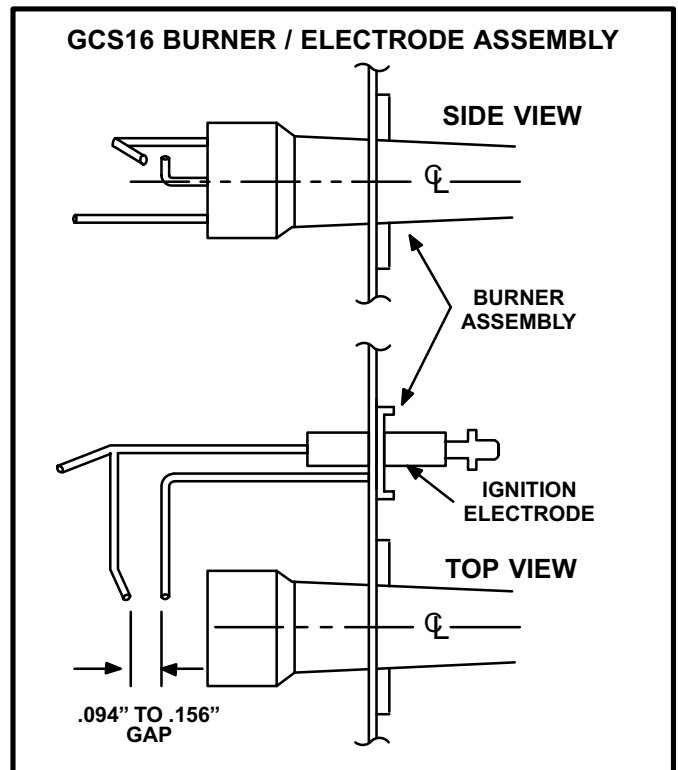

FIGURE 35

- 5-When finished, disconnect power to unit before disconnecting meter. Make sure sensor wire is securely reconnected before reconnecting power to unit.

NOTE - If the meter scale reads 0, the leads are reversed. Disconnect power and reconnect leads for proper polarity.

O-Combustion Air Blower B6

The combustion air blower, prove switch, connecting hose and orifice are factory set and are not field adjustable. However, operation should be monitored to ensure proper operation. The combustion air blower is used to draw fresh air into the combustion chamber while simultaneously expelling exhaust gases. The blower operates throughout the heating cycle. On a heating demand, the combustion air blower immediately energizes but the ignition control circuit does not. Once the combustion air blower is energized and moving air through the heat exchanger, the combustion air prove switch closes to energize the ignition control. The ignition control then begins attempting ignition after 30-40 seconds.

If the combustion air blower does not reach full speed or if the hose connecting the blower to the prove switch is obstructed, the prove switch will not close and the ignition control will not energize.

P-Blower/Limit Control S10/K25

Check blower control by operating unit through a heating cycle. If blower recycles after demand is satisfied, control should be adjusted. In any case, blower “off” settings above 90°F will cause the blower to recycle frequently (after a heating cycle) due to residual heat in the heat exchange assembly. Blower “off” settings above 90°F may also cause nuisance trips of secondary limit S10.

Before adjusting control, disconnect all power to unit. To adjust the blower control, move the “FAN ON” lever (figure 13) as needed so the “FAN OFF” lever can be set. Controls in all GCS16, GCS16R and GCS16H units use a bi-metal sure-start heater and the the “FAN ON” lever is non-functional. Set the “FAN OFF” lever to a position below 90°F. Reassemble unit, reconnect power, and operate unit through a heating cycle. If blower recycles after heating demand, repeat procedure and adjust control to a lower setting.

The limit setting is factory preset and must not be adjusted.

VIII-INDOOR BLOWER OPERATION / ADJUSTMENT

A-Blower Operation

NOTE - The following is a generalized procedure and does not apply to all thermostat control systems.

- 1- Blower operation is dependent on the thermostat control system option that has been installed in the GCS16. Refer to the section “Control System Options” for detailed descriptions of blower operation.
- 2- Generally, blower operation is set at the thermostat subbase fan switch. With the fan switch in the “ON” position, the blower operates continuously. With the fan switch in the “AUTO” position, the blower cycles with demand (or, with some control systems, runs continuously while the heating or cooling circuits cycle).
- 3- In most cases, the blower and entire unit will be off when the system switch is in the “OFF” position. The only exception is immediately after a heating demand until blower control switches off.

B-Determining Unit CFM

- 1- The following measurements must be made with a dry indoor coil. Run the blower without the cooling demand. Air filters must be in place when measurements are taken.
- 2- Measure static pressure external to the unit (from supply to return).

To Measure Discharge Static Pressure:

- a- Measure tap locations as shown in figure 36.
 - b- Punch a 1/4” diameter hole. Insert manometer hose flush with the inside edge of hole or insulation. Seal around the hole with permagum. Connect the zero end of the manometer to the discharge (supply) side of the system. Connect the other end of the manometer to the return duct as above.
 - c- With only the blower motor running, observe the manometer reading.
 - d- Seal around the hole when the check is complete.
- 3- The CFM can be adjusted by changing the motor speed taps. Follow the blower speed change instructions below.

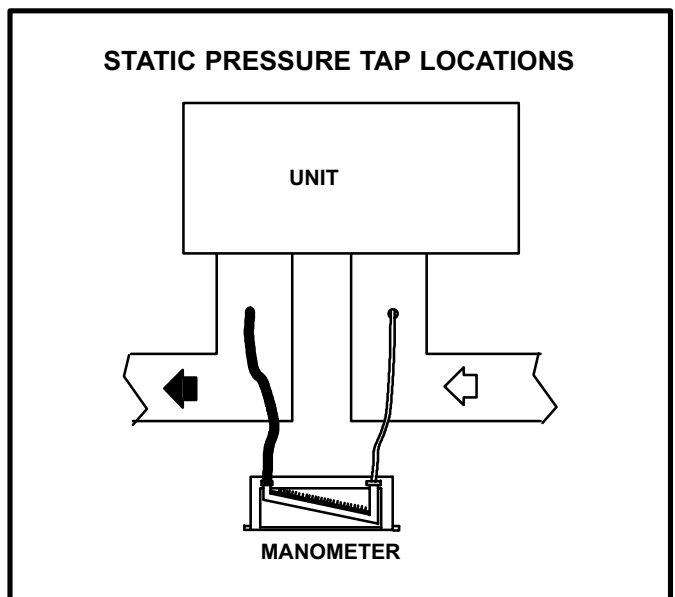

FIGURE 36

C-Blower Speed Adjustment 208v/230v ONLY

All -261, -311, -411 and -413 units (208/230V only) have four speed leadless blower motors. The speed ports are arranged as shown in table 17.

TABLE 17

FOUR SPEED BLOWER MOTORS	
Speed	Tap Number
Low	5
Medium-Low	4
Medium-High	3
High	2
Common	1

All -511, -513, -651 and -653 units (208/230V only) have five speed leadless blower motors. The speed ports are arranged as shown in table 18.

TABLE 18

FIVE SPEED BLOWER MOTORS	
Speed	Tap Number
Low	6
Medium-Low	5
Medium	4
Medium-High	3
High	2
Common	1

Blower speed selection is accomplished by changing the taps in the harness connector at the blower motor (see figure 37). Blower speeds are shown in table 19.

TABLE 19

Unit	208v/230v FACTORY SET BLOWER SPEED		
	Cool (port)		Heat(port)
	208v	230v	
-261	High (2)	High (2)	Med-Hi (3)
-311	High (2)	High (2)	Med-Hi (3)
-411-50	Med-Hi (3)	Med-Lo (4)	Low (5)
-411-100	Med-Hi (3)	Med-Hi (3)	Med-Lo (4)
-413-50	Med-Hi (3)	Med-Lo (4)	Low (5)
-413-100	Med-Hi (3)	Med-Hi (3)	Med-Lo (4)
-511	Medium (4)	Med-Lo (4)	Medium (4)
-513	Medium (4)	Med-Lo (5)	Medium (4)
-651-75	Med-Hi (3)	Medium (4)	Med-Lo (5)
-651-125	Med-Hi (3)	Medium (4)	Med-Lo (5)
-653-75	Med-Hi (3)	Medium (4)	Med-Lo (5)
-653-125	Med-Hi (3)	Medium (4)	Med-Lo (5)

Each motor port in a leadless motor (figure 37) is analogous to speed taps (pigtailed) used in previous Lennox units. Each motor is capable of four or five different speeds depending on unit (refer to unit wiring diagram). Each unit

is factory wired to provide a single cooling speed and a single heating speed. The speeds can be changed by moving the cooling wire or the heating wire to a different port at the harness connector.

Heating Speed:

Factory blower speeds are listed in a table on the unit wiring diagram. Adjust the blower heating speed for proper air temperature rise (listed on unit rating plate). To measure temperature rise, place thermometers in the supply and return air plenums. Turn up thermostat to start the unit. After plenum thermometers have reached their highest and most steady readings, subtract thermometer readings. The difference should be in the range listed on unit rating plate. If this temperature is high, wire the blower to a higher speed; if resulting temperature is too low, wire the blower to a slower speed. Repeat this procedure until desired temperature rise is obtained.

Cooling Speed:

Factory blower speeds are listed in a table on the unit wiring diagram. Blower performance tables are listed in the first section of this manual. Section "VIII-B-Determining Unit CFM" shows how to measure discharge static pressure. Once discharge static pressure has been determined, compare the value to the blower performance tables listed in the first section of this manual. If CFM is low, wire the blower to a higher speed; if CFM is high, wire the blower to a lower speed. Repeat this procedure until desired CFM is reached.

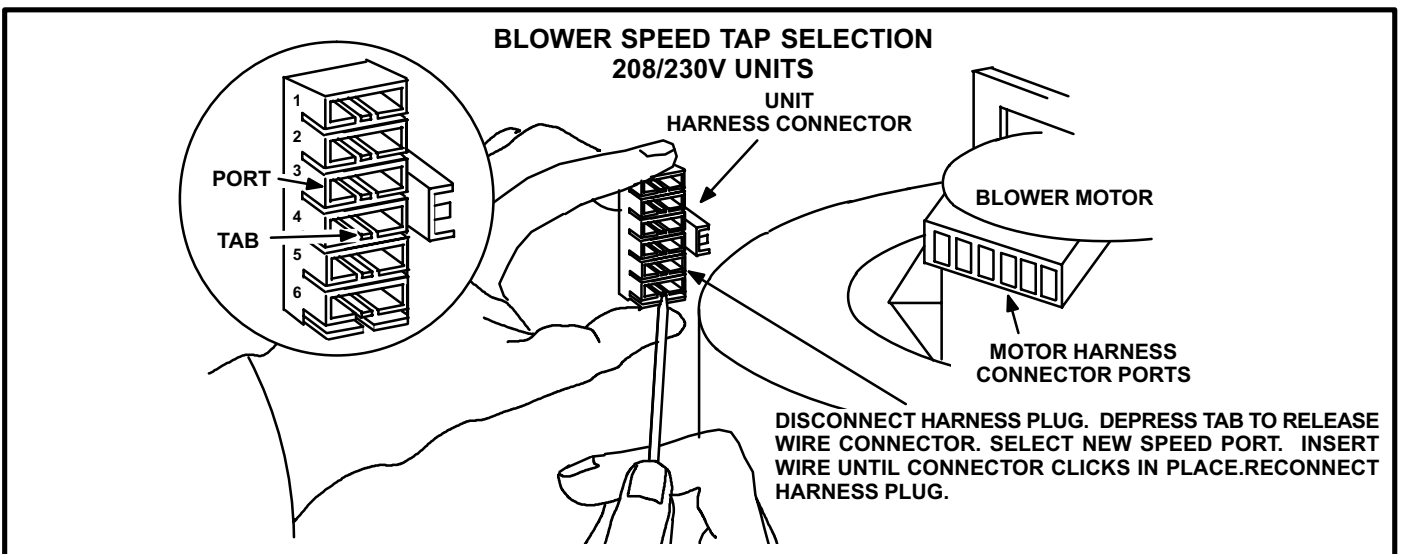

FIGURE 37

D-Blower Speed Adjustment 460V and 575V Units ONLY

All 460V and 575V units have three speed blower motors with pigtail leads (taps). The taps are arranged as shown in table 20. Both 460V and 575V units use 460V blower motors. 575V units use a step-down transformer in the unit control box to provide 460V to the motor.

TABLE 20

FOUR SPEED BLOWER MOTORS	
Speed	Tap Color
Low	Red
Medium	Yellow
High	Black
Internal Circuit	Blue
Common	Orange

The motor is equipped with speed leads (taps) for changing motor speed. The taps are connected to harness plug P38 along with line voltage wires from blower relay. Jumper J38 is used to complete the circuit to the blower motor and provide the proper heating and cooling speed. J38 is also used to provide the necessary “blue leg” circuit which 460V motors require (refer to figure 24 for more information). Blower speed selection is accomplished by changing the harness jumpers in the harness connector at the blower motor (see figure 38).

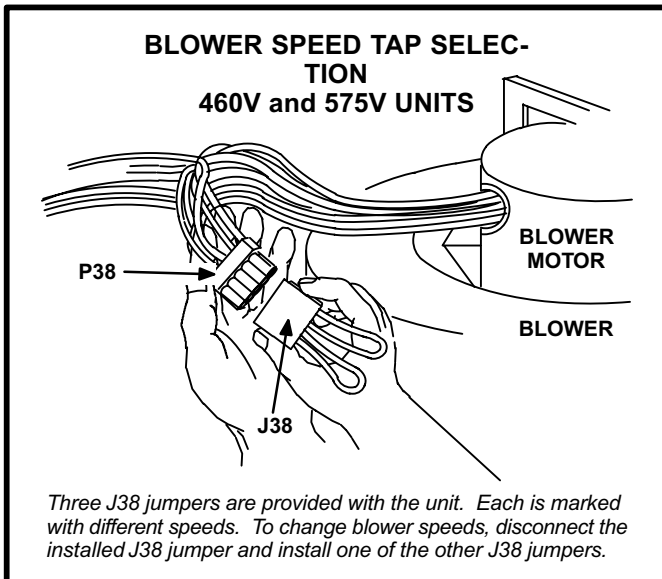

FIGURE 38

Three J38 jumpers are provided with the unit. Each provides the speeds marked on the jack (Hi-Cool / Lo-Heat, Med-Cool / Med-Heat or Hi-Cool / Med-Heat) and the “blue leg” circuit referred to in figure 24.

Use the steps outlined in the previous section (Blower Speed Adjustment 208V/230V Only) to determine which J38 jumper to use.

WARNING - DO NOT ISOLATE MEDIUM OR LOW SPEED WINDINGS WHEN OPERATING AT MEDIUM OR LOW SPEED. THE BLUE LEAD MUST NEVER BE CONNECTED TO A POWER LEAD (BLOWER DEMAND FROM HEAT RELAY OR BLOWER RELAY) OR TO COMMON. FAILURE TO CONNECT THE BLUE TAP AS SHOWN ON THE UNIT DIAGRAM WILL CAUSE IMPROPER OPERATION, INCREASED CURRENT FLOW AND/OR BURNT WINDINGS.

IX-MAINTENANCE

CAUTION - TURN OFF GAS AND ELECTRICAL POWER TO THE UNIT BEFORE PERFORMING ANY MAINTENANCE OR SERVICE OPERATION ON THE UNIT. REMEMBER TO FOLLOW LIGHTING INSTRUCTIONS ATTACHED TO THE UNIT WHEN PUTTING THE UNIT BACK INTO OPERATION.

BE CAREFUL WHEN SERVICING UNIT TO AVOID ACCIDENTAL CONTACT WITH SHARP METALLIC EDGES WHICH MAY CAUSE INJURY.

A-Lubrication

NOTE - Always relubricate motors according to manufacturer's lubrication instructions provided on each motor. If no instructions are provided, use the following as a guide:

- 1- Supply Air Motor Bearings - Bearings are prelubricated; no further lubrication is required for 10 years of normal operation. Thereafter, oil at oiling ports or clean and repack bearings with a suitable bearing grease every two years, whichever is applicable.
- 2- Combustion Air Blower Motor Bearings - Bearings are prelubricated. For extended bearing life, lubricate each bearing through the oiling ports provided. Use a few drops of a good grade of electric motor oil or SAE10 or SAE20 non-detergent motor oil every two years.
- 3- Condenser Fan Motor Bearings - Bearings are prelubricated. For extended bearing life, lubricate each bearing through the oiling ports provided with a few drops of a good grade electric motor oil or SAE10 or SAE20 non-detergent motor oil every two years.

B-Filters

GCS16 units require field provided field installed filters. Filters should be installed in the return air duct. A filter kit is available for downflow discharge applications. Filters should be checked monthly (or more frequently in severe use) and cleaned or replaced regularly. Take note of the "AIR FLOW DIRECTION" marking on the filter frame when re-installing.

NOTE - Filters must be U.L.C. certified or equivalent for use in Canada.

C-Heat Exchanger

- 1- Visually check all air and exhaust passages regularly. They must be clean and clear of debris and dirt accumulation.
- 2- Periodically check heat exchanger (once every few heating seasons). Remove unit side panel adjacent to heat exchanger (GCS16/GCS16R) or top panel (GCS16H). Inspect heat exchanger casting (primary) and tailpipe (secondary) for cracks. Replace if cracked. Refer to "Heating System Service Checks" section for heat exchanger access and removal procedure.
- 3- Inspect burner plate gasket and burner cone for deterioration. Replace if necessary. Refer to "Heating System Service Checks" section for heat exchanger removal and burner manifold assembly removal procedures.
- 4- Inspect gasket(s) between tailpipe (secondary) and combustion air blower for deterioration. Replace if necessary.

D-Burner

- 1- Before each heating season and periodically thereafter, examine the burner flame for proper appearance.
- 2- Before each heating season examine the burner and flue for any deposits or blockages (rodent nest, wasp nest, etc.) which may have occurred.
- 3- Clean burner as follows:
 - a-Turn off both electrical power and gas supply to the unit.
 - b-Remove the access panel to the burner compartment.
 - c-Remove the burner as outlined in section "VII-H-In-shot Burner."
 - d-Slide burner off orifice. Remove all debris from burner. Remove debris from all passages within retention ring.

- e-Remove spark/sensor electrode assembly from burner plate. Check the spark electrode and flame sensing electrode gaps. Re-install the burner and ensure that the burner head is lined up correctly with flame spreader. Replace the four screws securing the gas/burner manifold to the burner plate.

IMPORTANT - BURNER ENCLOSURE MUST BE REASSEMBLED TAKING CARE NOT TO CREATE AIR LEAKS DUE TO MISALIGNMENT OF PARTS. AIR LEAKS WILL ADVERSELY AFFECT UNIT PERFORMANCE.

Secure the gas manifold bracket and double check burner head alignment with flame spreader.

- f- Restore electrical power and gas supply. Follow the lighting instructions attached to the unit and check the burner flame. Flame should be blue with clear yellow streaking. If the burner does not appear to be operating correctly stop the unit, disconnect power and gas and adjust as necessary. Replace the access panel when finished.

E-Combustion Air Blower

All GCS16s use combustion air blowers with pre-lubricated, sealed, stainless-steel ball bearings.

A differential pressure switch (combustion air prove switch) is used to prove combustion air blower operation. If the blower is obstructed, the switch will not close and the ignition control will be locked out.

Under normal operating conditions, the combustion air blower wheel should be inspected prior to the heating season to determine if cleaning is necessary. With the power supply disconnected, the condition of the blower wheel can be determined by looking through the vent opening.

Maintenance consists of:

- 1- Checking prove switch. Prove switch should close at the factory setting shown in table 3.
- 2- Check the combustion air pressure switch hose for blockage or deterioration. Replace if necessary.
- 3- Position hose so accumulated condensate can drain from the switch into blower housing.
- 4- Clean combustion air blower assembly.

Combustion air blowers on 125,000 Btuh heat exchangers can be removed but cannot be disassembled for cleaning. Do not attempt to disassemble the blower.

To clean combustion air blower:

- 1- Shut off power supply and gas to the unit.
- 2- Remove the screws retaining the vent cap and combustion air blower to the end panel. Clean the vent cap as necessary.

IMPORTANT - Pay close attention to the order in which the flue orifice and gaskets are installed.

Inspect all gaskets for deterioration. Replace if necessary.

- 3- Remove the screws holding the blower housing to the flue box cover plate and wires attached to the motor.
- 4- If blower can be disassembled (50,000, 75,000, and 100,000 Btuh heat exchangers only), remove blower backplate as shown in figure 39. Clean blower blades with a small brush and wipe off any dust from the housing (see figure 39). Clean any accumulated dust from inside the flue box cover.

If blower cannot be disassembled (125,000 Btuh heat exchanger only), clean off any accumulated dust and reassemble.

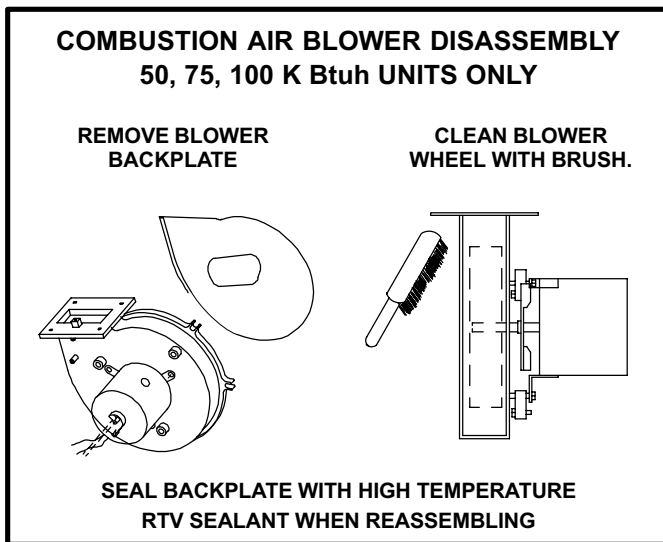

FIGURE 39

CAUTION - USE CARE WHEN CLEANING COMBUSTION AIR BLOWER WHEEL. WHEEL IS MADE OF ALUMINUM AND MAY DISTORT IF TOO MUCH PRESSURE IS APPLIED.

- 5- Reassemble combustion air blower by reversing this procedure. Seal backplate with high temperature RTV sealant when reassembling.
- 6- Reconnect tubing connecting blower to flue box. Arrange tubing so that it can drain accumulated condensate.
- 7- Clean the vestibule panel louvers using a small brush.

F-Flue

Make sure the flue is clean and free of debris.

G-Evaporator Coil

- 1- Clean coil, if necessary.
- 2- Check connecting lines and coil for evidence of oil leaks.
- 3- Check condensate drain pan and line, if necessary.

H-Condenser Coil

- 1- Clean and inspect condenser coil. (May be flushed with a water hose.)
- 2- Visually inspect connecting lines and coils for evidence of oil leaks.

NOTE - If owner complains of insufficient cooling, the unit should be gauged and refrigerant charge checked. Refer to Gauge Manifold Attachment, Checking Charge and Charging sections in this instruction.

I-Electrical

- 1- Check all wiring for loose connections.
- 2- Check for correct voltage at unit (unit operating).
- 3- Check amp-draw on both condenser fan motor and blower motor.
Fan Motor Rating Plate ____ Actual ____
Indoor Blower Motor Rating Plate ____ Actual ____

X-ELECTRICAL CONNECTIONS

A-Power Supply

Refer to start up directions and refer closely to the unit wiring diagram when servicing. Refer to the unit nameplate for minimum circuit ampacity and maximum fuse size. 208/460/575 volt units are wired with a red wire connecting transformer T1 primary to L1. 230 volt units use an orange wire connecting transformer T1 primary to L1.

B-Field Wiring

Unit and optional control field wiring is shown in the unit diagram section of this manual.

XI-ACCESSORIES

This section describes the application of most of the optional accessories which can be connected to the GCS16. Some of the accessories (for example, the Warm Up Control Kit) are described in the operation sequence section of this manual.

A-Lifting Lug Kit

Optional lifting lug kit consists of four brackets like the one shown in figure 40. The brackets are used for lifting the unit during installation or when servicing. Lifting lugs are not supplied with the unit. Lifting lugs can be removed from the unit and reused.

A tethered pin is inserted in the bracket and through a hole in the base channel of the unit. The pin is used only to hold the bracket in place; it does not support any weight. The bracket bottom lip supports the weight of the unit.

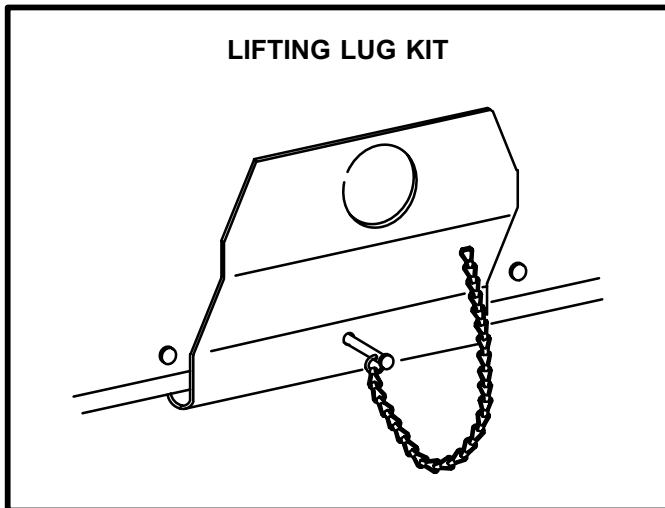

FIGURE 40

TABLE 21

Unit	Maximum Unit Weight
GCS16H-261/311-50/75	380 Lbs.
GCS16-411/413-50/100 GCS16R-411-50/100	500 Lbs.
GCS16-511/513/651/653-125 GCS16-651/653-75 GCS16R-511/651-125 GCS16R-511-75	650 Lbs.

If unit must be lifted for service, use only lifting lugs and cables with spreader bars to lift unit. Table 21 shows maximum unit weight. Figure 41 shows how to rig the unit for lifting. To prevent cabinet damage never use chains for lifting unit.

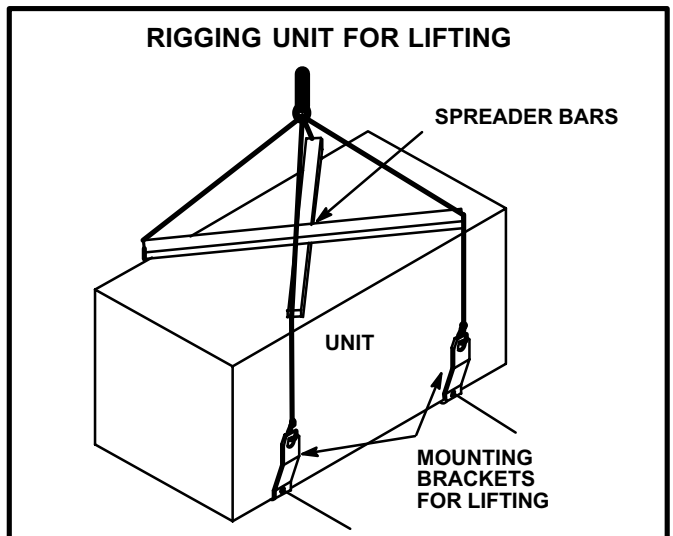

FIGURE 41

B-RMF16 Mounting Frame

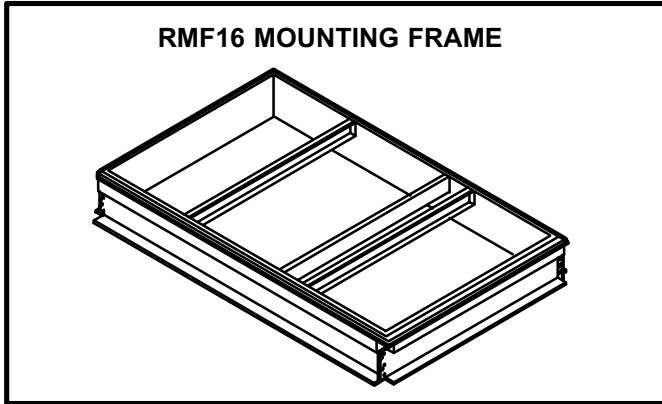

FIGURE 42

When installing a GCS16 unit on a combustable surface for downflow discharge applications, the Lennox RMF16 roof mounting frame (figure 42) is required. Otherwise, the RMF16 is recommended but not required. The GCS16, if not mounted on a flat (roof) surface, **MUST** be supported under all edges and under the middle of the unit to prevent sagging. The GCS16 **MUST** be mounted level within 1/16" per linear foot in any direction.

The assembled RMF16 mounting frame is shown in figure 42. Refer to the RMF16 installation instructions for details of proper assembly and mounting. The roof mounting frame **MUST** be squared to the roof before mounting. Plenum system **MUST** be installed before the unit is set on the mounting frame. Refer to the RMF16 installation instructions for proper plenum construction.

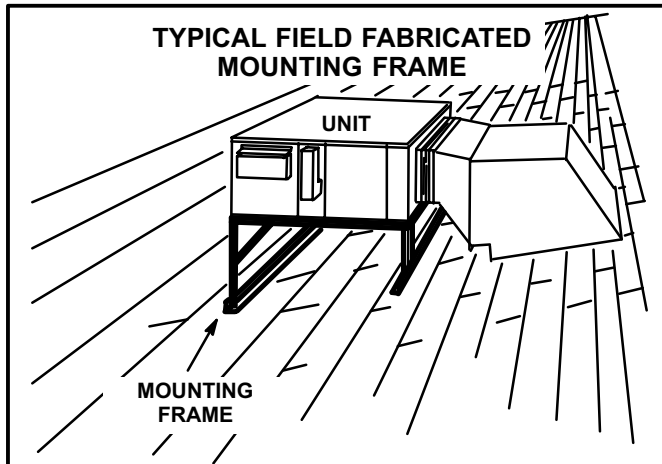

FIGURE 43

Many types of roof framing or supports can be used to mount the GCS16 unit, depending upon different roof structures. A typical field fabricated roof mounting frame is shown in figure 43.

C-Economizers

1-Application

REMD16(M) and EMDH16(M) economizers can only be applied to GCS16 commercial units. GCS16R (residential) units are not equipped with the necessary wiring hardware and therefore cannot accept the economizers.

GCS16H units are not designed to accept economizers and are not equipped with the necessary wiring. However, a REMD16M or REMD16 can be field applied to a GCS16H if necessary by using a RDE16-41 downturn transition. This application is covered in more detail later in this section.

A total of eight different economizers are available for GCS16 commercial units. Table 22 describes the economizers which are available.

TABLE 22

GCS16 ECONOMIZERS (2-5 TON UNITS)		
Economizer	Type	Unit Matchup
REMD16-41	Three Position Downflow	GCS16H-261 GCS16H-311 GCS16-410
REMD16M-41	Modulating Downflow	GCS16H-261 GCS16H-311 GCS16-410
REMD16-65	Three Position Downflow	GCS16-510 GCS16-650
REMD16M-65	Modulating Downflow	GCS16-510 GCS16-650
EMDH16-41	Three Position Horizontal	GCS16-410
EMDH16M-41	Modulating Horizontal	GCS16-410
EMDH16-65	Three Position Horizontal	GCS16-510 GCS16-650
EMDH16M-65	Modulating Horizontal	GCS16-510 GCS16-650

2-REMD16 Downflow Economizer
REMD16M Downflow Economizer

The REMD16 and REMD16M economizers (figure 44) are designed for use with standard (downflow) GCS16s. The economizer opens a set of dampers to allow 0 to 100 percent outdoor air to be used for cooling when outdoor humidity and temperature are acceptable. Additional (2nd stage) cooling demand is directed to the compressor while the dampers remain open. If outdoor air becomes unacceptable, the outdoor air dampers close to a predetermined minimum position while the compressor cooling circuit cycles as needed.

Refer to the REMD16-41/65 Installation Instruction Manual for specific details regarding installation. Refer to the sequence of operation flowcharts (in back of this manual) for detailed operation of the economizer. The sequence of operation flowcharts also describe how the economizer interacts with the GCS16 and the control system being used.

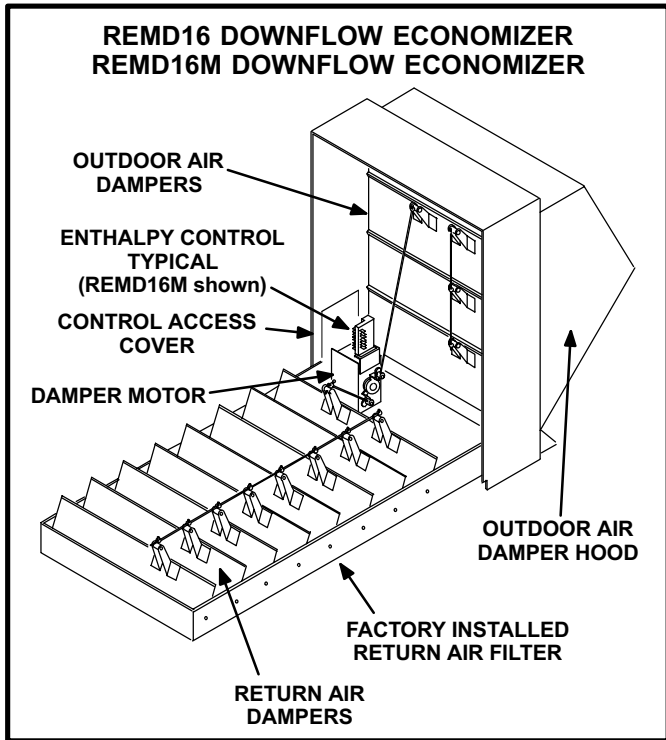

FIGURE 44

3-EMDH16 Horizontal Economizer
EMDH16M Horizontal Economizer

The EMDH16 and EMDH16M economizers (figure 45) operate like the REMD16 and REMD16M except they are designed for GCS16 units requiring horizontal discharge and return air. Internal components and operation of the horizontal economizer are identical to the downflow economizer.

Refer to the EMDH16-41/65 Installation Instruction Manual for specific details regarding installation. Refer to the sequence of operation flowcharts (in back of this manual) for detailed operation of the economizer. The sequence of operation flowcharts also describe how the economizer interacts with the GCS16 and the control system being used.

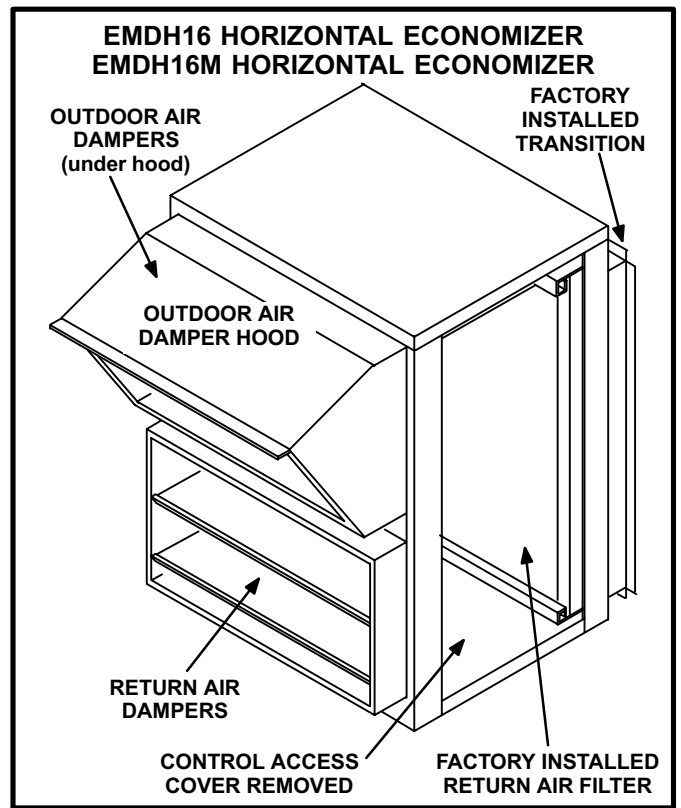
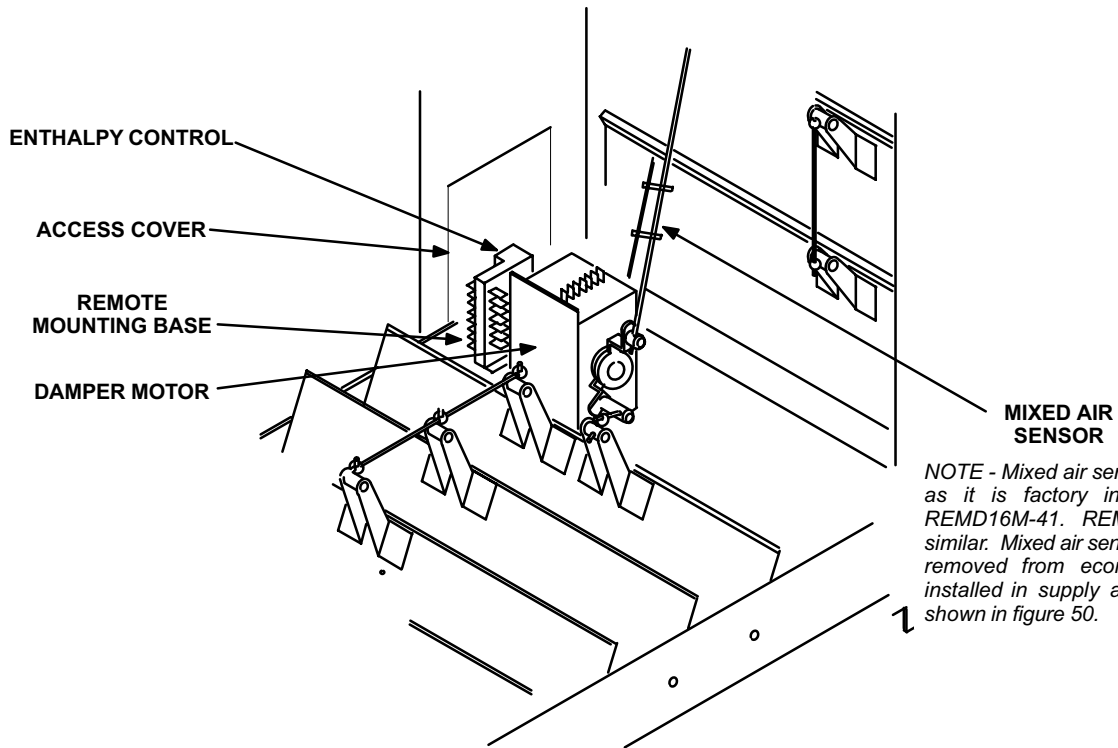

FIGURE 45

The physical location of controls in the REMD16M and REMD16 economizers is shown in figure 46. The physical location of controls in the EMDH16M and EMDH16 economizers is shown in figure 47.

REMD16M PARTS ARRANGEMENT



REMD16 PARTS ARRANGEMENT

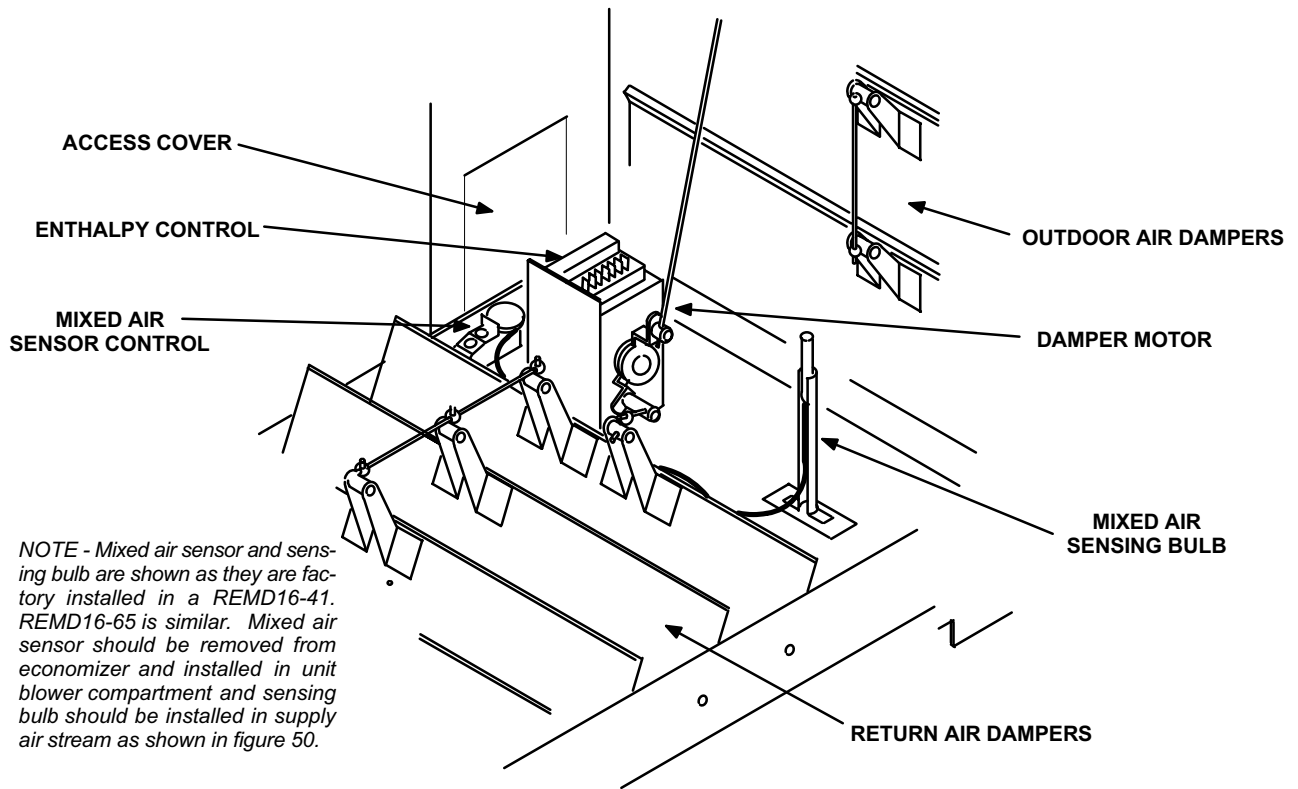
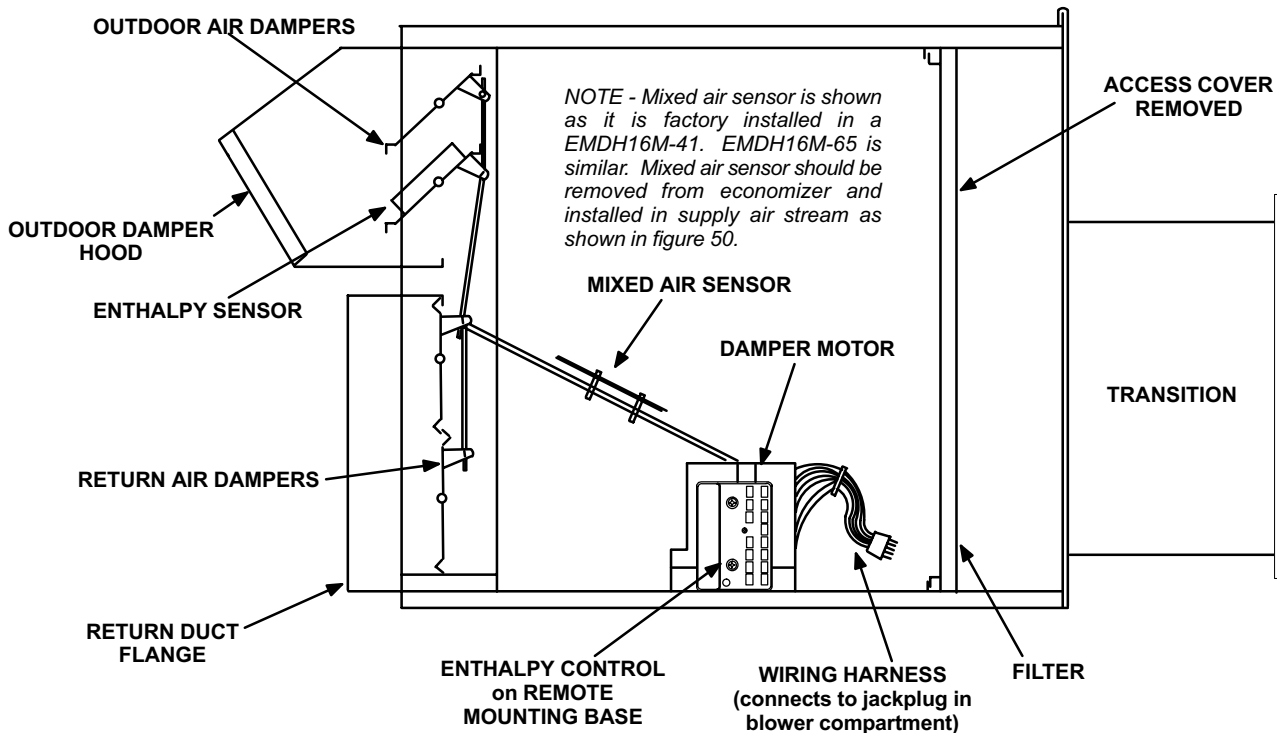

FIGURE 46

EMDH16M PARTS ARRANGEMENT



EMDH16 PARTS ARRANGEMENT

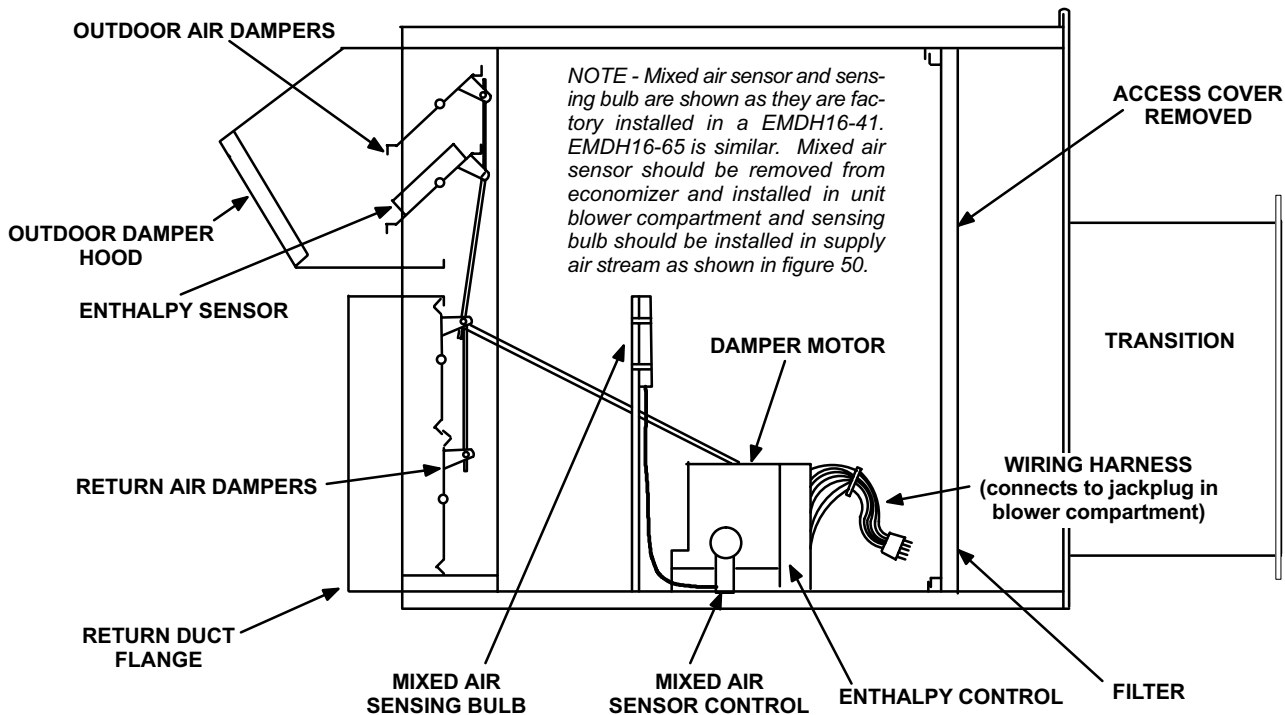

FIGURE 47

4-Economizer Operation

a-Enthalpy Control: Setpoint Control

The key to economizer operation is the enthalpy control. The enthalpy control senses the total heat content of the outside air (temperature plus humidity) and uses that information to control the amount of outside air brought into the system. When the enthalpy of the outside air is below the control setpoint, the control actuates a motor which in turn adjusts the outdoor dampers to meet the cooling demands of the building. When the heat content rises above the control setpoint, the control de-activates and the dampers close to the preset minimum (not closed) position.

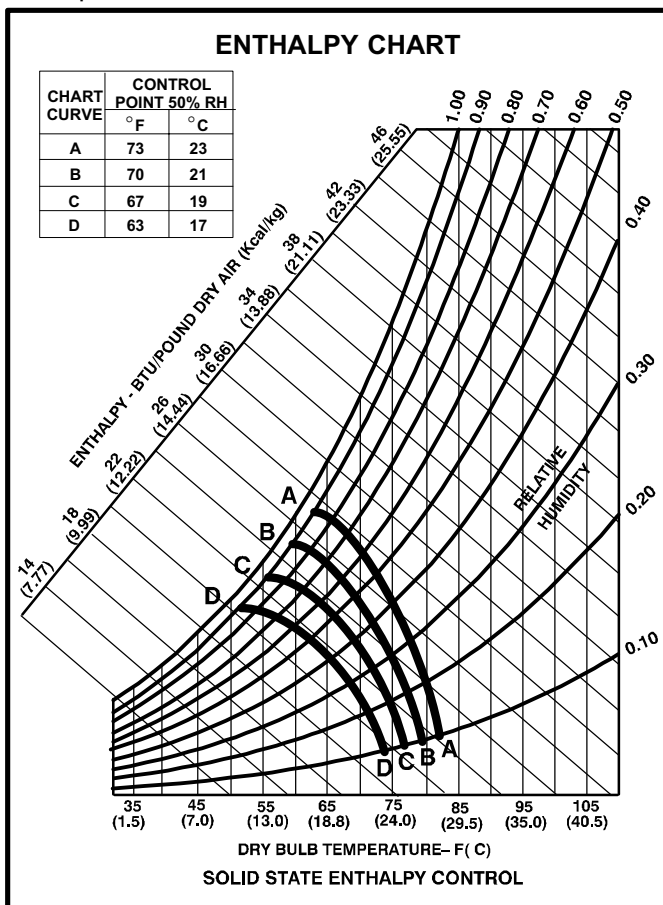

FIGURE 48

Two types of adjustment may be made at the control. The first is the control setpoint. The setpoint determines the temperature and humidity conditions at which the outdoor air dampers will open and

close. The recommended setpoint is "A." If the economizer is allowing air which is too warm or too humid into the system, the control may be changed to a lower setpoint (B,C or D). Refer to enthalpy chart figure 48.

Example:

If the enthalpy control is set at setpoint "A" as shown in figure 48, the following situation could occur. A cooling demand when the outside air is at 75° and 20 percent humidity would drive the economizer outdoor air dampers open to utilize outdoor air for cooling. The compressor cooling circuit would be disabled. However, if the outdoor air should change to 70° F (a drop in temperature) and 70 percent humidity (a dramatic rise in humidity), the "total heat content" of the outdoor air would rise above the enthalpy control setpoint and deactivate the damper motor to the preset minimum position. If cooling demand is still present when the total heat of the outside air rises above the control setpoint, cooling demand is routed from the economizer to the compressor cooling circuit.

b-Minimum Positioner

The second type of adjustment which may be made at the control is the minimum position of the outdoor damper blades. Each economizer has a minimum positioner switch (potentiometer) which allows the outdoor dampers to be adjusted to a preset minimum position. This allows a preset amount of air exchange at all times during unit operation. When unit operation stops, the dampers drive fully closed. The potentiometer is located on the enthalpy control face (modulating economizer) or on the damper motor (three position economizer.)

c-Enthalpy Sensor

The enthalpy sensor is located on the outside portion of the outdoor damper blades (as shown in figure 49). The sensor monitors the total heat content of the outdoor air (temperature plus humidity) and sends the information to the enthalpy control. The enthalpy control uses the information to determine if outdoor air can be used for cooling.

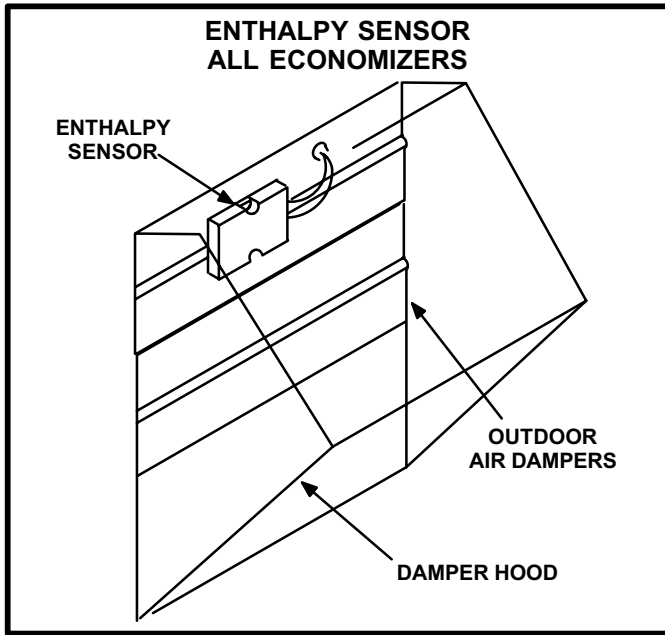

FIGURE 49

d-Mixed Air Sensor

The sensor measures the resultant temperature of the mixed air downstream of the evaporator coil. The mixed air temperature is used by the enthalpy control when outdoor dampers are open to help determine whether outdoor air dampers should close. Modulating economizers are equipped with a single mixed air sensor. Three position economizers are equipped with a separate sensor (switch) and sensing bulb which are connected by a cap tube.

The mixed air sensor (bulb) is located in the supply air stream. The sensor (modulating economizer) or sensing bulb (three position economizer) fits through a factory supplied hole in the panel dividing the unit return and supply air (see figure 50). The three position economizer sensor (switch) mounts to pre-drilled holes in the unit panel dividing return and supply air.

e-Wiring, Installation, Maintenance

The economizer uses a harness plug to connect to the GCS16's harness connector located in the blower compartment. Refer to figure 51 for REMD16 installation or figure 52 for EMDH16 installation. Although a harness connector is used to connect the GCS16 to the economizer, the economizer electrically connects to the GCS16 differently depending on which control system has been installed. The different electrical connections are made in relay kits and controls located in the control area of the blower

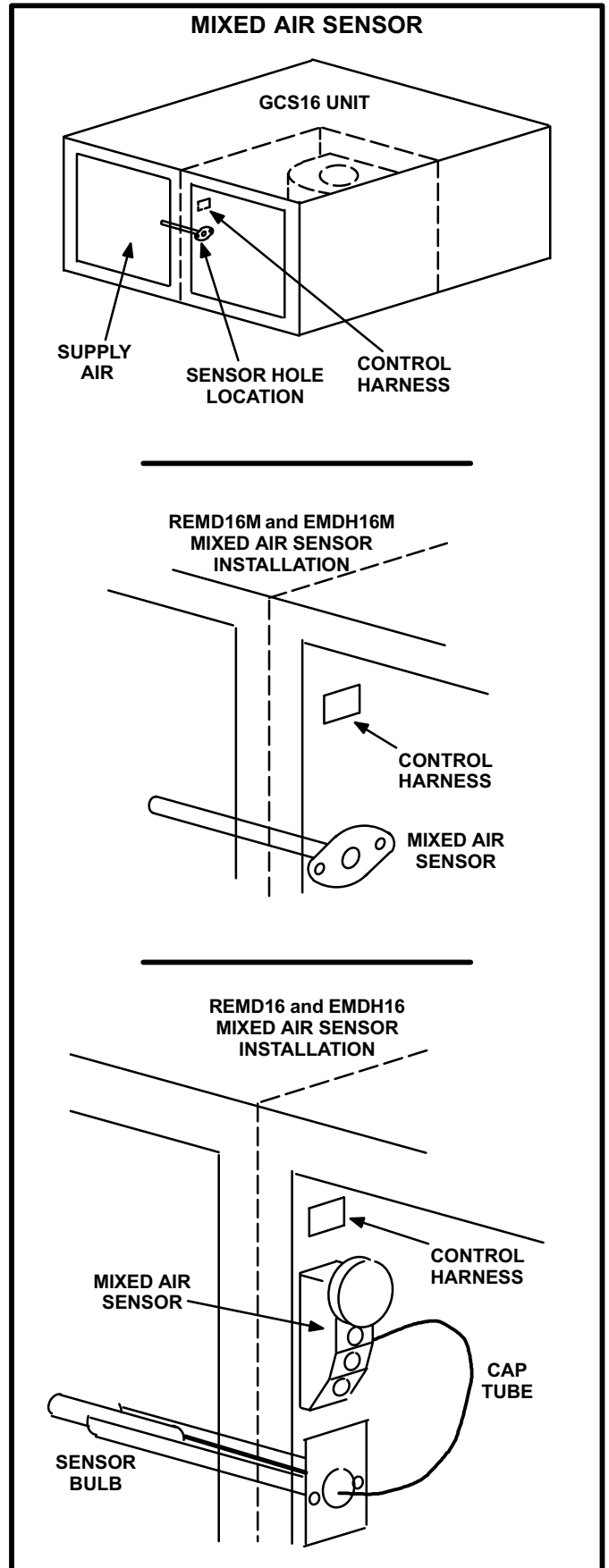

FIGURE 50

compartment. All connections are made with quick-connect type harness connectors. For specific details of economizer wiring and operation, refer to the sequence of operation section of this manual.

Figure 51 shows how an REMD16 is installed in a GCS16 cabinet. Figure 52 shows how an EMDH16 is installed in a GCS16 cabinet. For detailed installation and maintenance instructions, refer to the REMD16-41/65 Installation Instruction Manual or the EMDH16-41/65 Installation Instruction Manual.

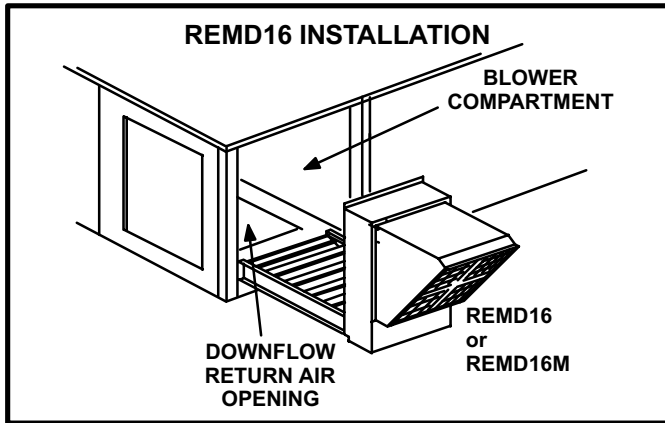

FIGURE 51

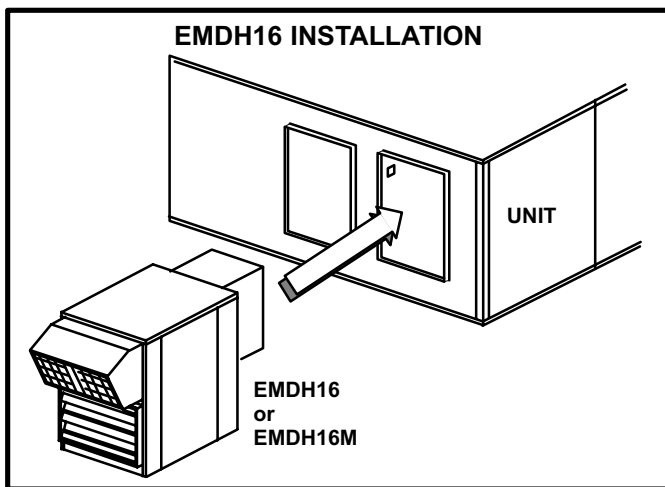

FIGURE 52

f-Modulating Damper Motor Check

Honeywell W7459A

- 1- Disconnect main power to the GCS16.
- 2- Turn thermostat control to OFF position (occupied mode).
- 3- Install jumper across terminals 6-9 on blower relay in unit control box.
- 4- Install jumper across enthalpy control terminals T and T1. See figure 53 for terminal location.

- 5- Restore power to unit. Outdoor damper should drive to fully open position (60 to 90 sec. required for full travel). Observe travel for proper damper operation.
- 6- Disconnect power to the unit. Outdoor damper should spring return to closed position.
- 7- Remove T and T1 jumper then restore power to the unit. Outdoor damper should drive to minimum position. Adjust minimum damper position pot located on control. See figure 53.
- 8- Disconnect power to unit and remove jumper on blower relay terminals 6-9. Replace all panels. Restore power to unit.

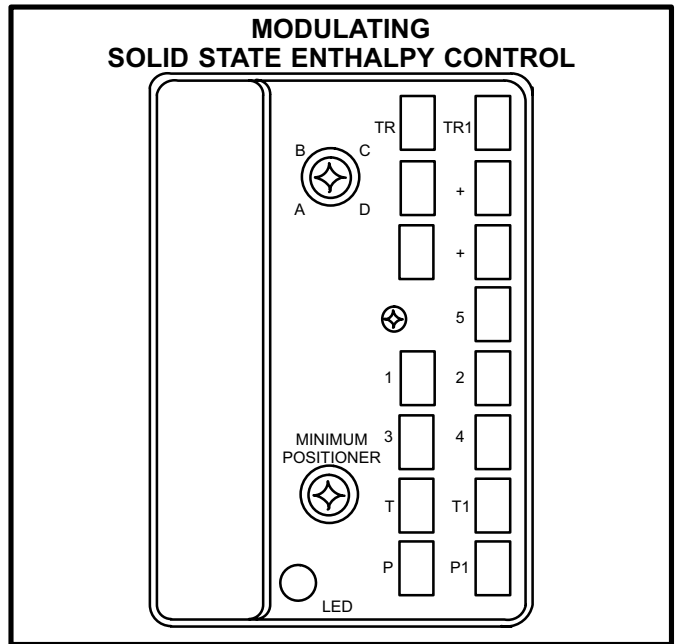

FIGURE 53

g-Three-Position Damper Motor Check

Honeywell W7459C

- 1- Disconnect main power to the GCS16.
- 2- Remove the control access cover (see figures 46 and 47).
- 3- Install jumper across enthalpy control terminals D and TR1. See figure 54 for terminal location.
- 4- Restore power to unit. Outdoor damper should drive to fully open position (requires approximately 90 seconds for full travel). Observe travel for proper damper operation.
- 5- Disconnect power to unit. Damper should spring return to closed position.
- 6- Remove jumper installed in step 3. Install jumper across enthalpy control terminals X and TR1. See figure 54 for terminal location.

- 7- Restore power to unit. Outdoor damper should drive to mid (minimum) position (requires approximately 90 seconds for full travel). Adjust minimum position by turning thumb wheel on damper motor.
- 8- Disconnect power to unit and remove jumper. Replace all panels. Restore power to unit.

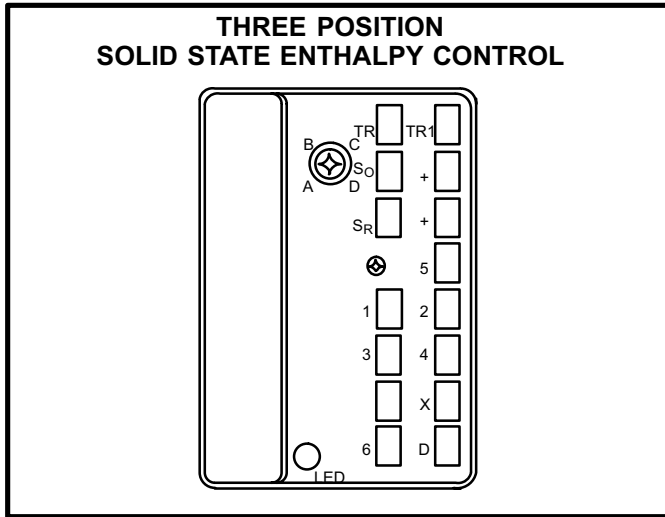

FIGURE 54

h-Warm Up Kit

An optional warm up kit may be added to either REMD16 or EMDH16 economizer (except GCS16s using a Honeywell W7400 Control System). The Warm Up Kit holds the dampers closed during night setback and morning warm up. When the first thermostat demand of the day is satisfied, the warm up kit opens the outdoor dampers to minimum position. The warm up kit mounts to the GCS16 in the control mounting area of the blower compartment. The kit plugs into the unit wiring harness in line between the unit and the economizer. For detailed wiring and operation, refer to the sequence of operation section of this manual.

i-Night Relay

Optional night relay must be added to economizer when night setback functions are desired with W973 or electromechanical control systems. Kit includes a

DPDT relay which is hard-wired to the economizer harness.

If a W973 system is used, the relay holds the outdoor dampers closed during setback. If an electro-mechanical thermostat system is used, the relay holds the outdoor dampers closed during setback, de-energizes the indoor thermostat and energizes the setback thermostat. Night relay is not required for any other control system. Field wiring is shown in the following section section of this manual. Night relay wiring diagram designation is K11.

D-OAD16 Outdoor Air Damper

The OAD16 outdoor air damper section (figure 55) installs in the GCS16R or GCS16 to allow a fixed amount of outside air into the system. The OAD16 replaces the unit side panel where a downflow economizer would normally be installed. The dampers may be manually adjusted and locked in place to allow up to 25 percent outside air into the system at all times. Refer to the OAD16 installation instruction manual for specific installation procedure. The washable filter supplied with the OAD16 can be cleaned with water and a mild detergent. It should be sprayed with Filter Handicoater when dry prior to reinstallation. Filter Handicoater is R.P. Products coating no. 418 and is available as Lennox Part No. P-8-5069.

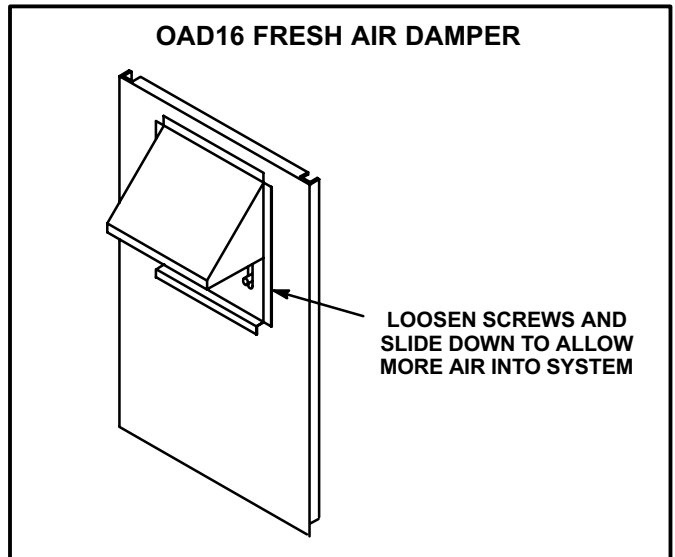

FIGURE 55

**E-RDE16-41 Duct Enclosure for
REMD16-41 and REMD16M-41
Economizer Limited Application
GCS16H Series Units Only**

GCS16H may be converted to downflow operation by adding an RDE16-41 downturn transition and RMF16-41 roof mounting frame as shown in figure 56. A manual outdoor air damper is factory provided with the RDE16. The damper is located in the access panel covering the economizer opening. The damper provides a field set amount of outdoor air exchange (0 to 25%) at all times.

REMD16-41 (or REMD16M-41) economizer may be used with GCS16H units in a limited downflow only application. However, neither economizer can be directly mounted to GCS16H. The RDE16-41 duct enclosure must be used to provide the proper opening for economizer. Duct enclosure RDE16-41 mounts to the GCS16H horizontal air openings and the economizer slides in the RDE16-41 economizer opening (see figure 57 for installation).

The GCS16H is not factory equipped with the necessary

wiring needed to connect an REMD16-41 or REMD16M-41. To compensate for the lack of unit harness, an economizer harness is provided in the RDE16-41. The economizer connects to the RDE16-41 harness using jackplugs. The RDE16-41 uses pigtails to hard-wire the economizer harness to the unit. Field wire routing is shown in figure 58. Field wiring is shown in figure 59.

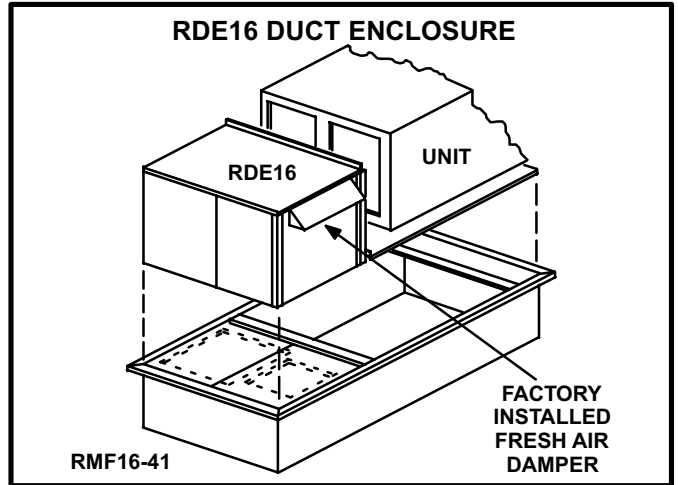

FIGURE 56

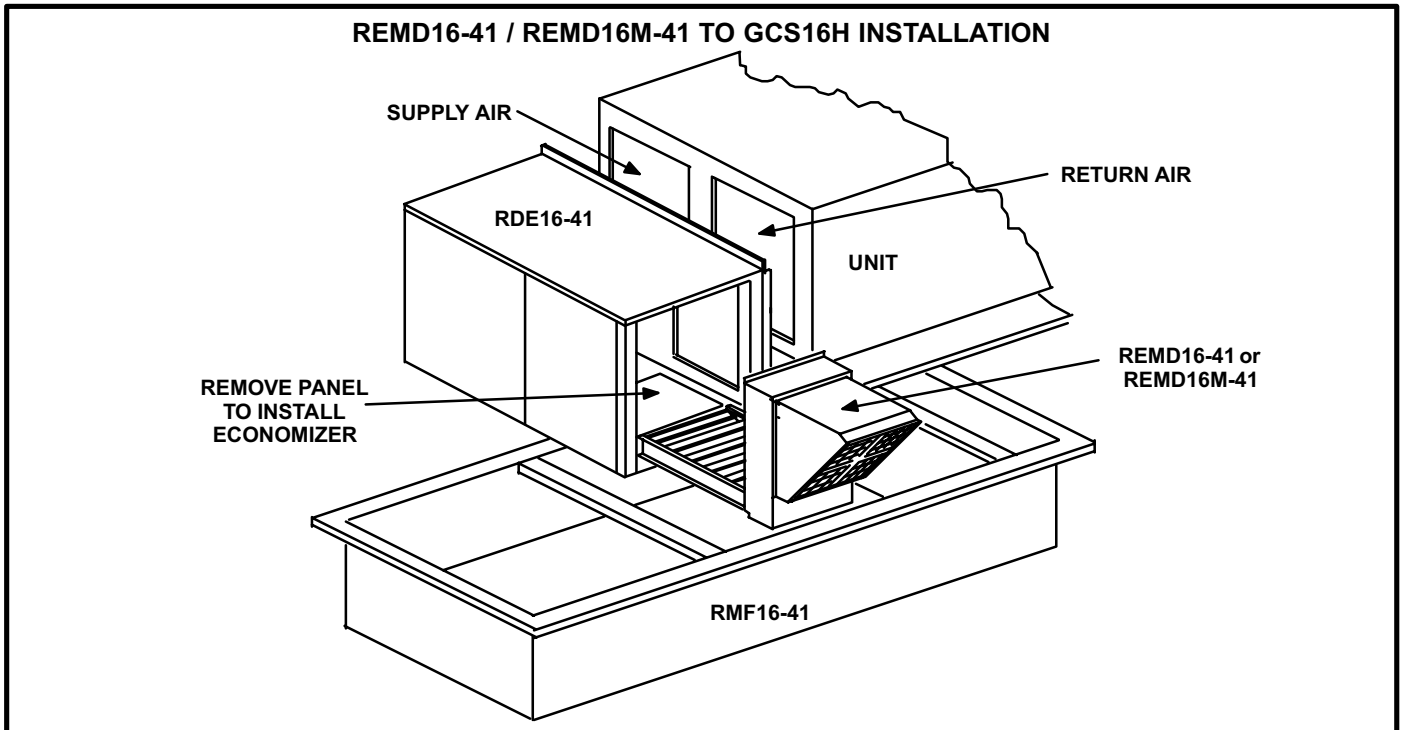

FIGURE 57

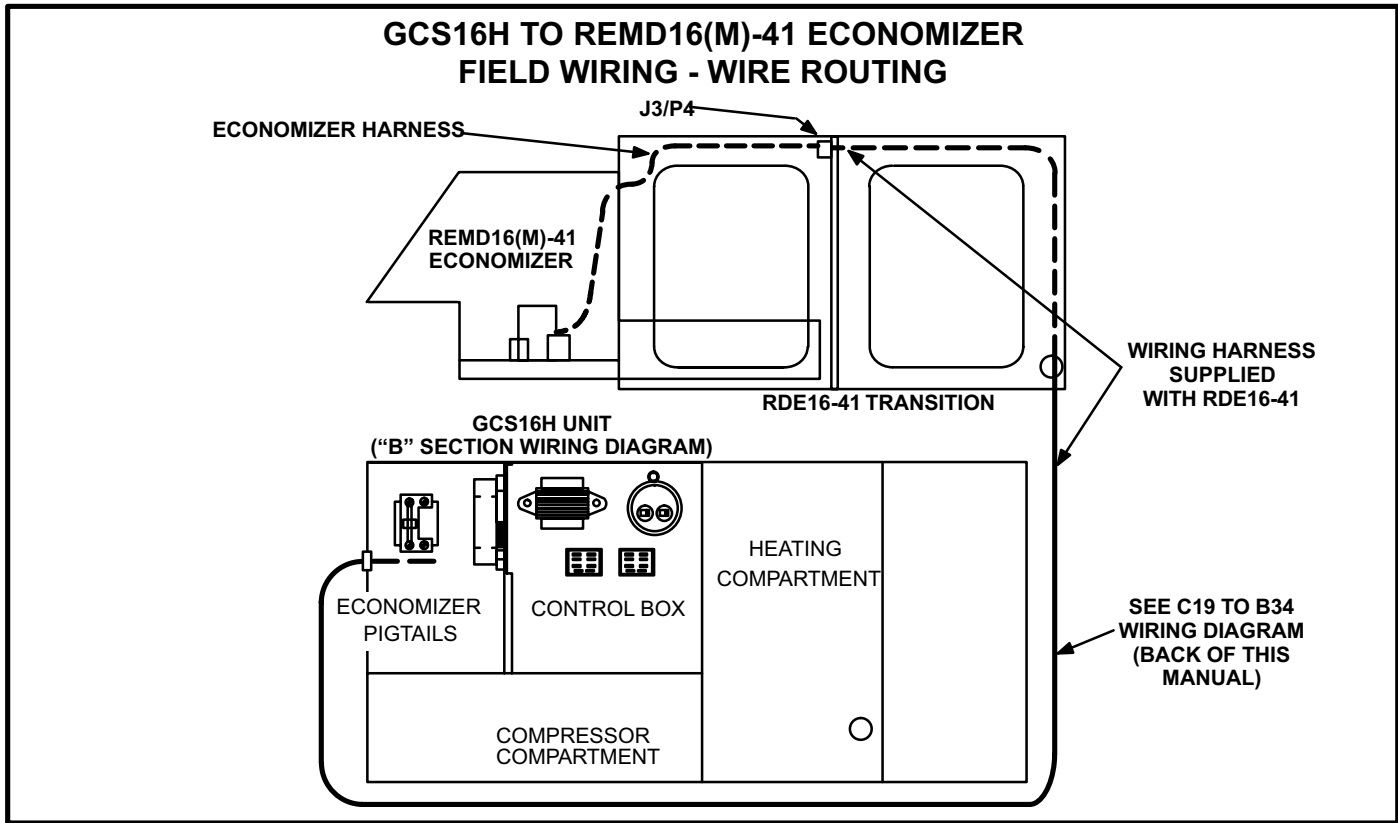

FIGURE 58

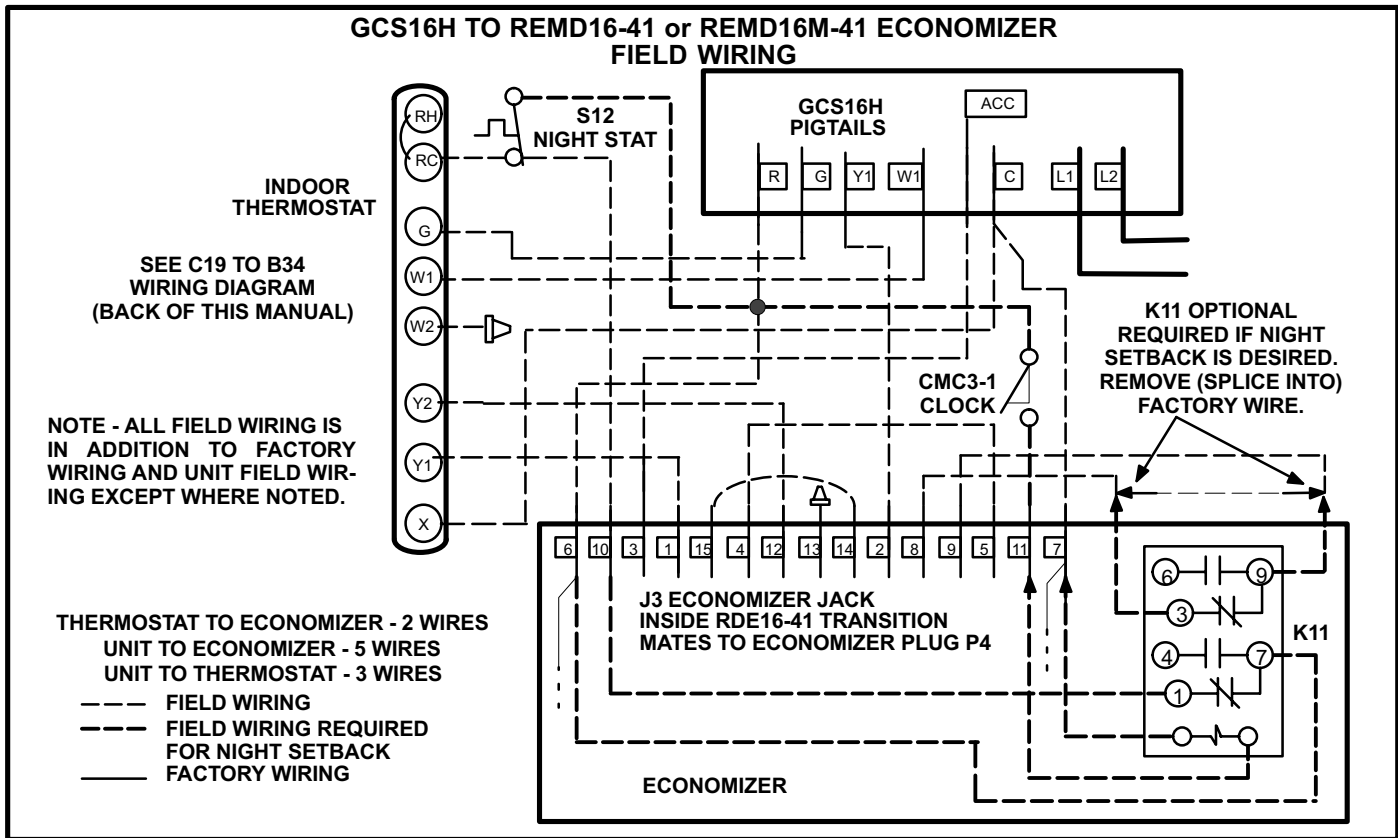

FIGURE 59

F-LPG Kit

All A.G.A. rated GCS16s are factory set for use with Natural Gas. An optional L.P.G. conversion kit allows change-over from Natural to L.P.G. supply. The kit includes a gas valve changeover kit, new gas orifice and either combustion air orifice or combustion air restrictor plate.

All C.G.A. rated GCS16s are factory set for use with Natural or L.P. gases. Each unit must be ordered for the type of gas to be used. Field changeover is not allowed.

Refer to the L.P.G. Conversion Kit Installation Instruction for specific installation procedures.

WARNING - IMPROPER INSTALLATION, ADJUSTMENT, ALTERATION, SERVICE OR MAINTENANCE CAN CAUSE INJURY, PROPERTY DAMAGE OR DEATH. CONSULT A QUALIFIED INSTALLER, SERVICE AGENCY OR THE GAS SUPPLIER FOR INFORMATION OR ASSISTANCE.

CONVERSION OF HONEYWELL GAS VALVE (Natural to LP)

1. Remove regulator cap screw and pressure regulator adjusting screw.
2. Remove existing spring.
3. Insert replacement spring with tapered end down.
4. Install the new plastic pressure regulator adjustment screw so that the top of the screw is flush (level) with the top of the regulator. Turn the pressure regulator adjusting screw clockwise six complete turns. This adjustment provides a preliminary pressure setting of about 10" w.c. (2.5 kPa) for the LP regulator.
5. Check regulator setting either with a manometer or by clocking the gas meter.
6. Install new cap screw.

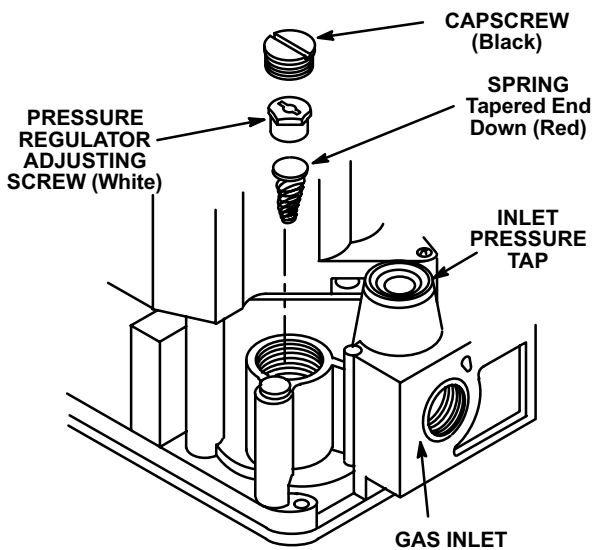

FIGURE 60

All units which have been changed to L.P.G. operation should be marked with a yellow sticker located near the gas valve. Some of the components you may find in a unit which has been converted to L.P.G. operation are listed below. Do not use this information as an installation procedure.

L.P.G. conversion in all GCS16 units requires that the gas valve be field converted and the burner orifice be changed. Figure 60 shows gas valve conversion. Figure 61 shows the orifice changeout.

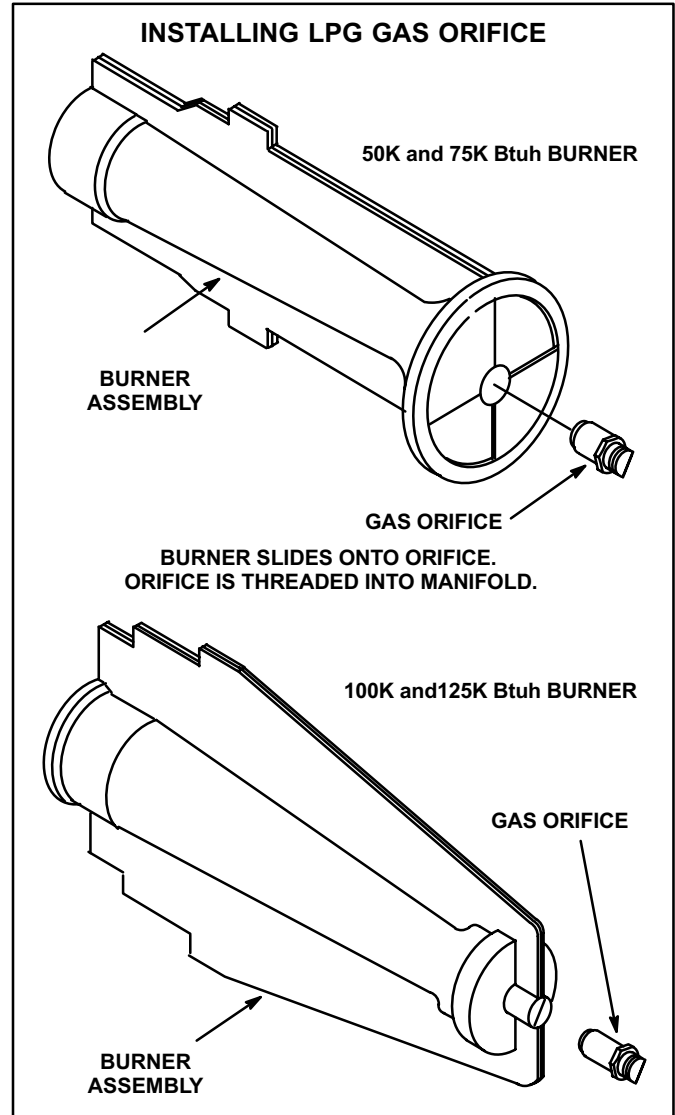

FIGURE 61

L.P.G. conversion of 50K Btuh heat exchangers requires a new combustion air orifice. In GCS16H-50 units, the orifice is located between the combustion air blower and the flue transition as shown in figure 62. In GCS16-50 and GCS16R-50 units, the orifice is located outside the cabinet between the outer mullion and the flue vent as shown in figure 63.

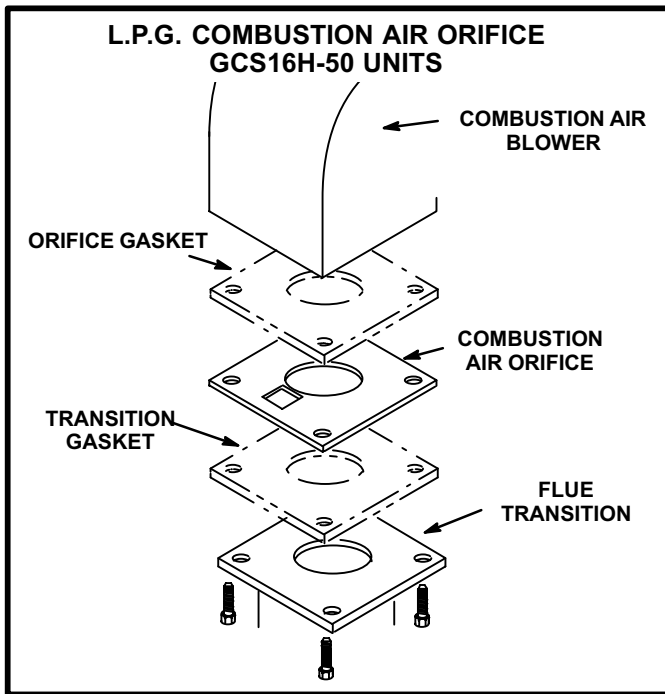

FIGURE 62

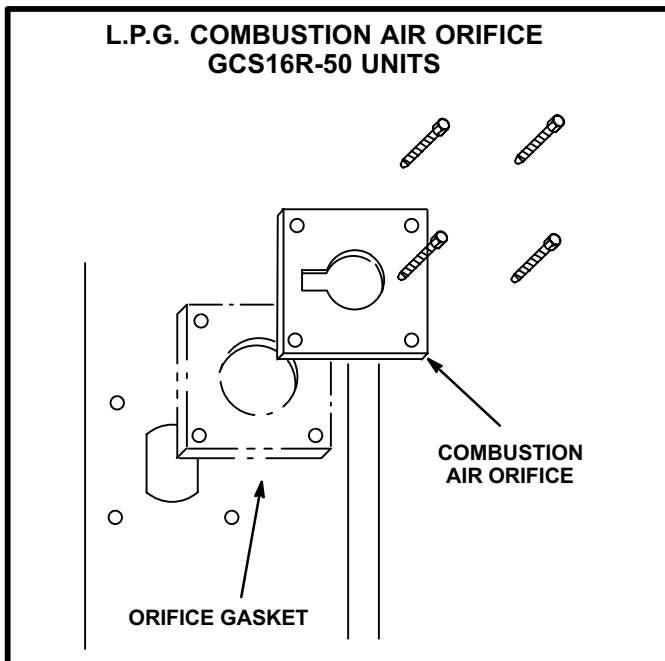

FIGURE 63

GCS16-50 and GCS16R-50 units also require a burner air restrictor plate which is used to cover some of the air intake holes surrounding the burner. The 50K Btuh burner restrictor plate is shown in figure 64.

All 75K, 100K and 125K Btuh units require a center air restrictor plate when converting from Natural to L.P. gas. The restrictor is used to cover the air intake space immediately surrounding the burner as shown in figure 65. In

units equipped with burner enclosure (figure 12), the enclosure must be carefully disassembled to gain access to the burner and restrictor plate.

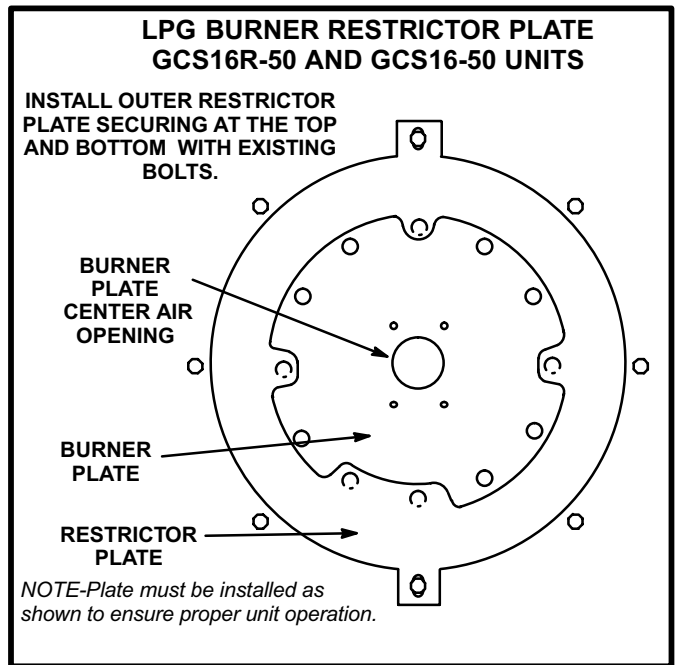

FIGURE 64

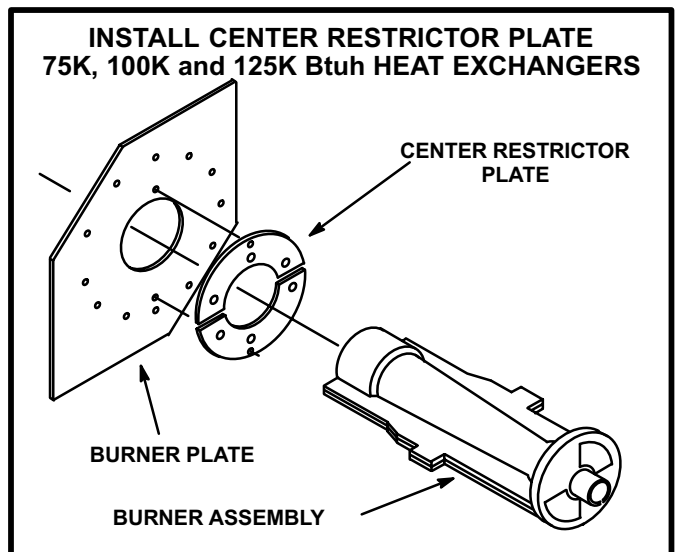

FIGURE 65

G-Condenser Coil Guard Kit

Optional condenser coil guard kit is available for all units. The kit includes PVC coated steel wire coil guard which is field installed. GCS16H units require one guard, GCS16-411/413 and GCS16R-411 units require two guards and GCS16-511/513/651/653 and GCS16R-511/651 require three guards.

H-High Altitude Kit (CGA only)

Optional CGA high altitude kit is not available at this time. If derate is required, follow the instructions in table 16.

I-Compressor Crankcase Heater GCS16R and GCS16H (208/230v) only

Optional compressor crankcase heater is available for field installation in any residential unit (208/230v only). The heater is a 45-watt belly-band-type and is wired directly to line voltage.

J-DF16 Downflow Filter Kit

Optional downflow filter kit may be added to any GCS16-410/510/650 unit. The kit provides a means for filtering (downflow) return air inside the cabinet. The kit includes rails which install in the blower compartment and allow the (one inch thick) filter (furnished) to slide in. Two kits are available. DF16-41 (figure 66) installs in -410 units and DF16-65 (figure 67) installs in -510/-650 units.

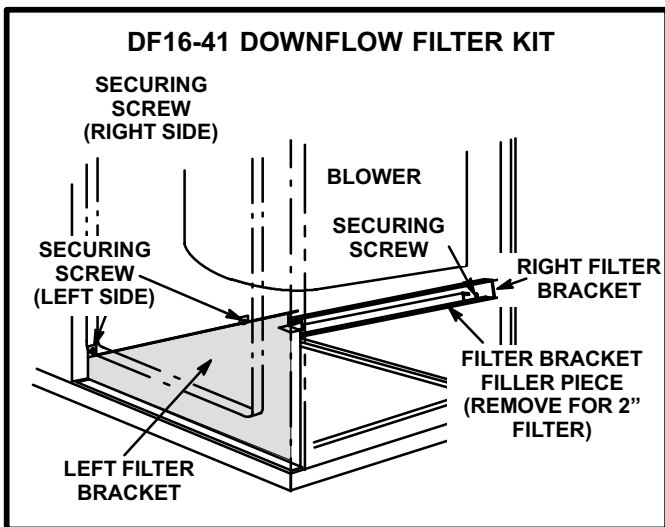

FIGURE 66

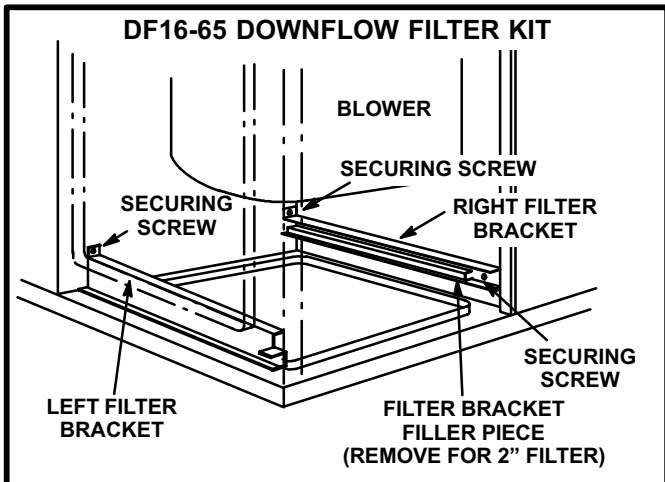

FIGURE 67

K-Timed-Off Control Kit (Figure 68)

Optional field installed timed-off controls prevent the GCS16 compressor from short cycling. After a thermostat demand, automatic reset timed-off control keeps compressor off for 3-7 minutes.

NOTE - Some electronic thermostats have built in timed-off delay. Field installed timed-off delay is not needed.

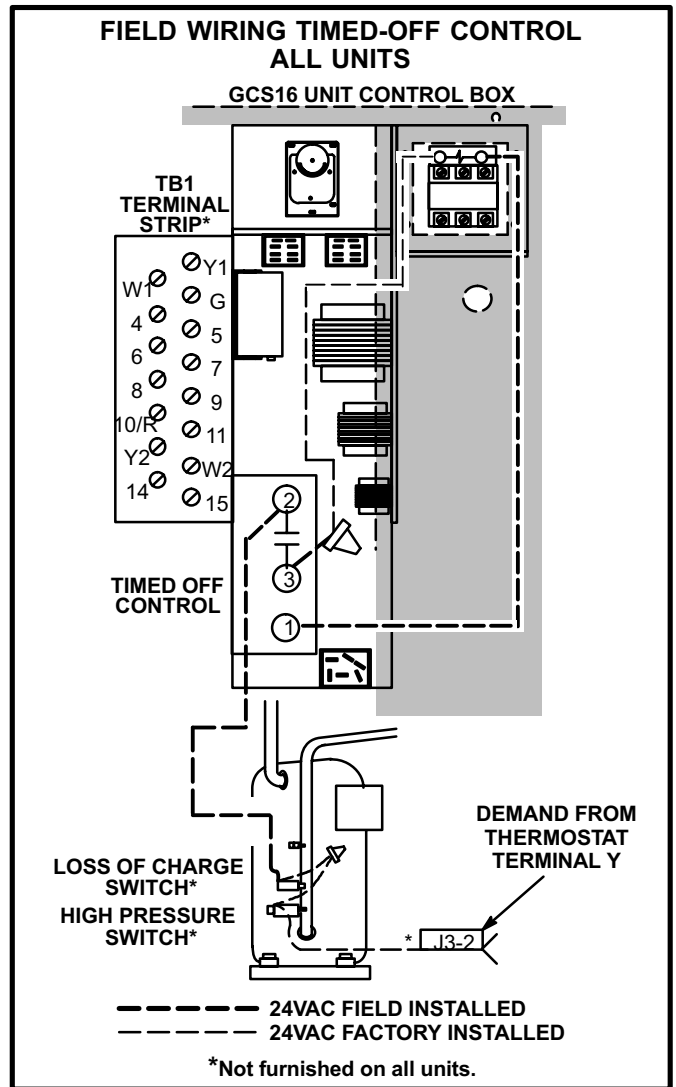

FIGURE 68

Operation:

- 1- If the compressor has been de-energized for more than 3-7 minutes, there will be a 3-10 second delay after receiving a thermostat demand before the compressor can be energized.
- 2- After the compressor has been de-energized, the timed-off control keeps the compressor de-energized for 3-7 minutes.

- 3- If a thermostat demand is present at the end of the 3-7 minute timed off period, the compressor is immediately energized.
- 4- If there is no thermostat demand at the end of the 3-7 minute timed off period, the compressor remains de-energized until the next thermostat demand when all safety circuits are closed.

Wiring:

- 1-Disconnect power to the unit.
- 2-Make wiring connections per wiring diagram in figure 68.

L-Optional Compressor Monitor(Figure 69)

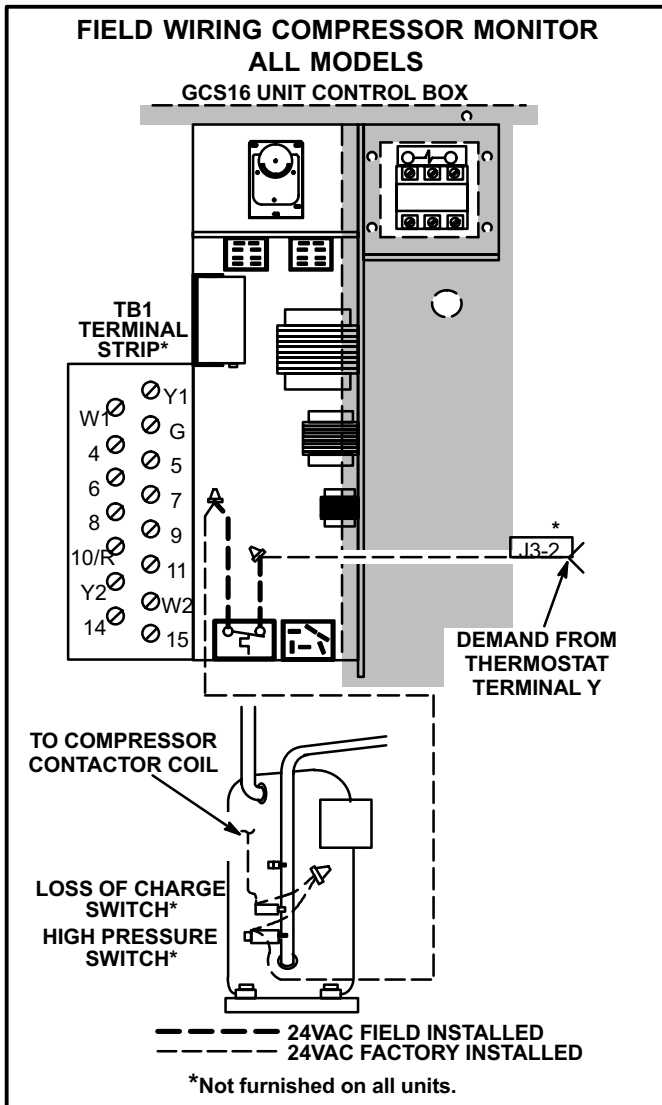

FIGURE 69

Optional compressor monitor can be installed in all units to provide low ambient protection for the compressor. The monitor (figure 69) is a N.O. temperature switch located in the control box area. It is wired in series with the compressor contactor. When ambient temperature drops below 40°F, the switch opens and de-energizes the circuit to the compressor contactor thereby protecting the compressor from low ambient operation.

M-Low Ambient Kit

The optional low ambient kit (figure 70) allows for mechanical cooling operation at low outdoor temperature.

CAUTION - Compressor monitor cannot be used with optional low ambient kit. Optional field installed compressor monitor MUST be disconnected before allowing low ambient kit to be used.

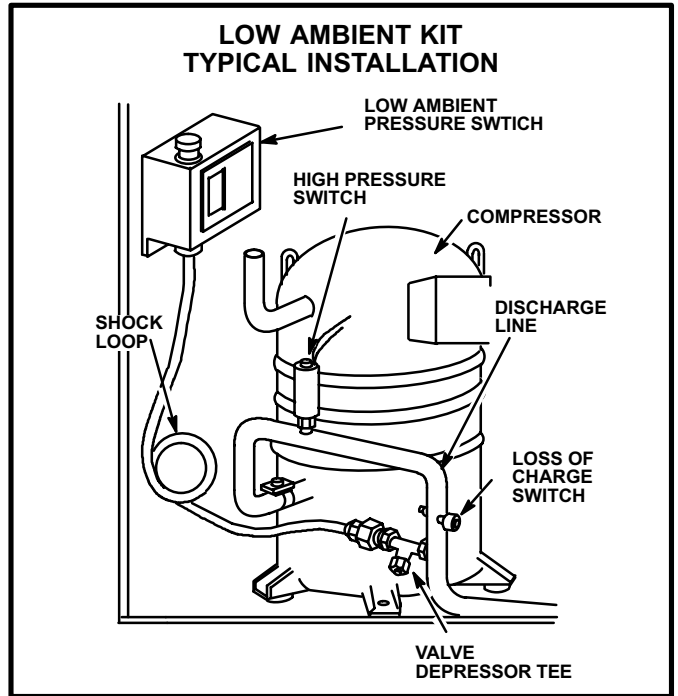

FIGURE 70

Low ambient kit field wiring is shown in figure 71. The low ambient pressure switch is wired in series with the condenser fan L1 lead. Refer to the low ambient kit installation instruction manual for detailed installation instructions.

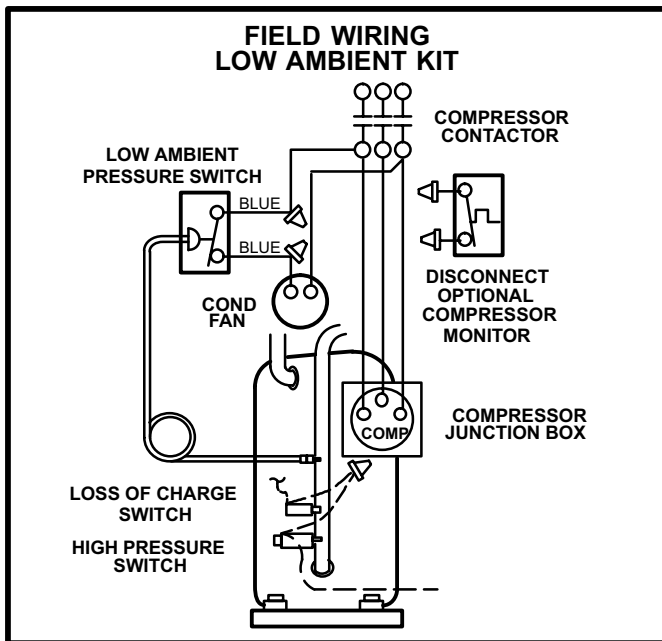

FIGURE 71

The low ambient pressure switch cycles the condenser fan while allowing normal compressor operation. This intermittent fan operation results in a high evaporating temperature which allows the system to operate without icing the evaporator coil and losing capacity.

Adjustment:

The low ambient pressure switch is adjustable but the adjustment knob *does not* adjust CUT-IN or CUT-OUT points. CUT-IN point is fixed and cannot be adjusted. The scale on the switch measures the difference in pressure between preset CUT-IN and adjustable CUT-OUT points. Adjustment knob changes CUT-OUT point by adjusting the DIFFERENCE between CUT-IN and CUT-OUT.

The low ambient pressure switch is factory set to CUT-IN at 285psig with a difference of 146psig (CUT-OUT at

140psig). Adjustment should not be needed. If adjustment is needed, adjust the switch as follows:

- 1- Loosen knob securing screw to allow knob stop to pass over fixed stop on control (see figure 72).

$DIFFERENCE \text{ (set by knob)} = CUT-IN \text{ POINT (fixed)} \text{ minus } CUT-OUT \text{ POINT}$

To find CUT-OUT point, this equation can be re-arranged:

$CUT-OUT = CUT-IN \text{ minus the } DIFFERENCE.$

- 2- Rotate the knob as needed to set the difference indicator at 145psig (1000kPa).
- 3-Tighten the securing screw after adjusting.

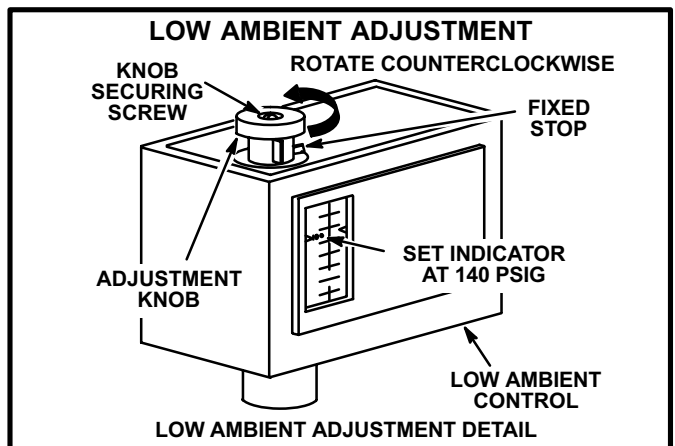

FIGURE 72

N-Roof Curb Power Kit

Optional Roof Curb Power kit allows line and low voltage power to be brought into unit from the RMF16 roof mounting frame. Figure 73 shows typical roof curb power kit installations. Roof Curb Power kit is applicable only to larger (-410, -510 and -650) unit sizes and can be used on both RMF16-41 and RMF16-65 roof mounting frames. Two 7/8" knockouts are provided along the long rails of each mounting frame for installation. All components in Roof Curb Power kit are field assembled and field installed.

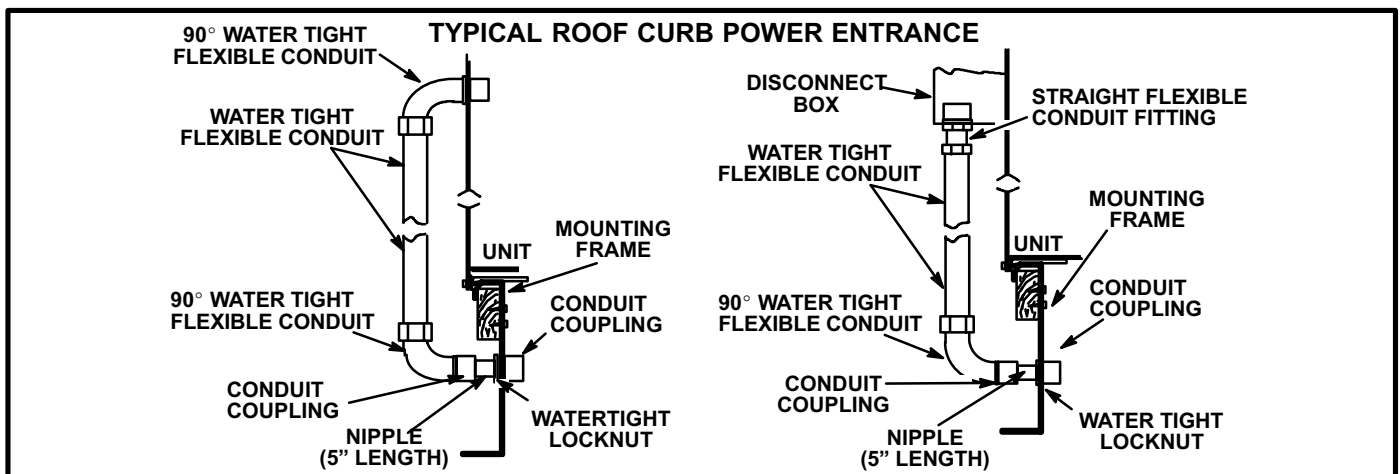

FIGURE 73

O-Firestats

Some local codes may require the installation of discharge air and return air firestats to automatically shut down the unit when excessive temperature is reached. Other local codes may require firestats wired to perform tasks such as energizing a blower or closing dampers. These field provided firestats **MUST** be mounted and wired per local codes or insuring agencies. Manual reset controls **MUST** be accessible.

Figures 74 and 75 show typical firestat wiring connections.

Figure 74 shows firestats connected inline with transformer T1 primary. When either or both firestats open, the control circuit is de-energized, the unit shuts down and the economizer outdoor air dampers drive full closed.

Figure 75 shows firestats connected inline with the 24VAC control circuit. When either or both firestats open, the control circuit is de-energized while control transformer T1 remains energized to operate dampers, exhaust blower, etc. The unit shuts down and economizer outdoor dampers drive full closed.

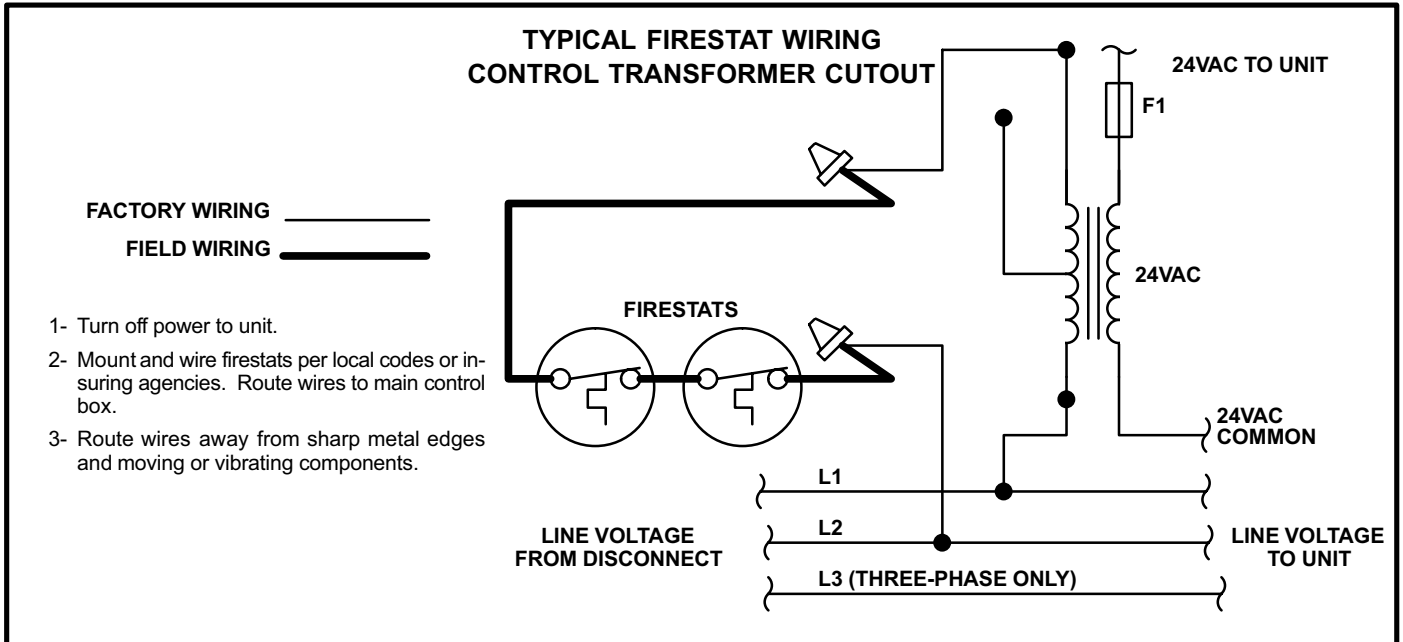

FIGURE 74

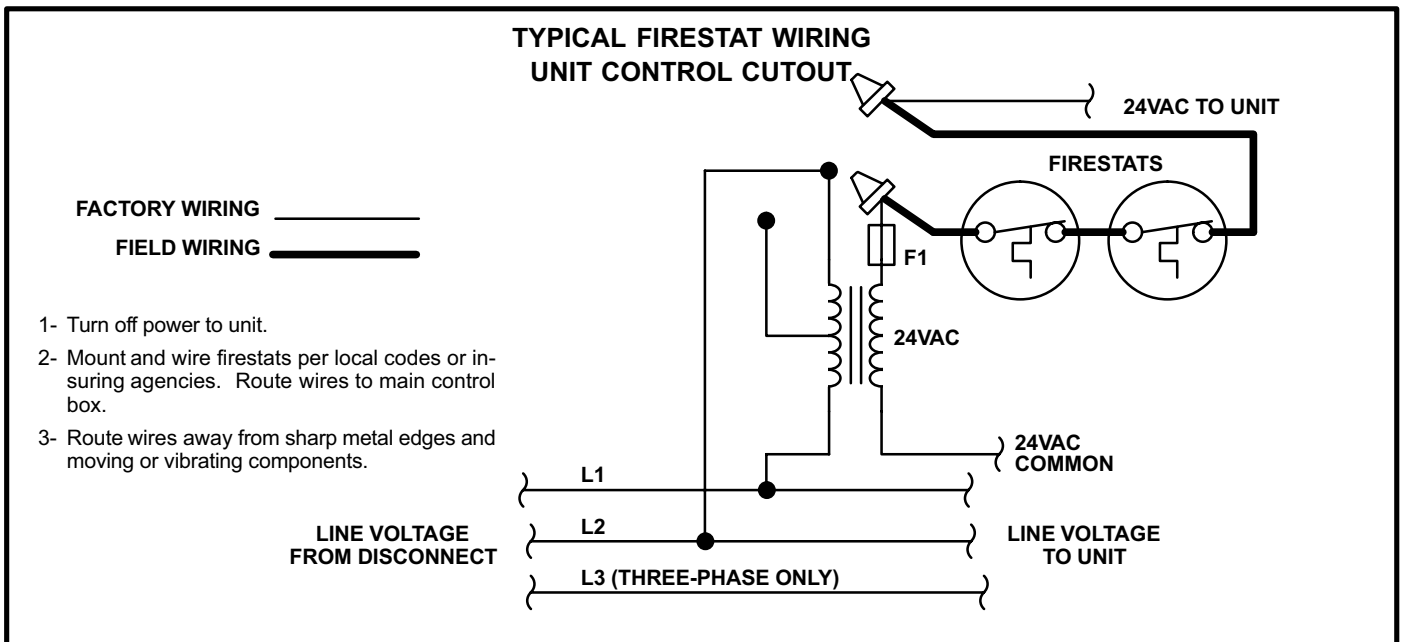

FIGURE 75

P-Transitions

Optional supply/return transitions (SRT16 AND SRTH16) are available for use with downflow GCS16s utilizing the optional RMF16 roof mounting frame. The transition must be installed in the RMF16 mounting frame before mounting the GCS16 to the frame. Refer to the manufacturer's instructions included with the transition for detailed installation procedures.

Q-Supply and Return Diffusers

Optional flush mount diffuser/return FD9-65 and extended mount diffuser/return RTD9-65 are available for use with the GCS16. Refer to the manufacturer's instructions included with the transition for detailed installation procedures.

R-Status Panels SP11 and SSP11

Optional status panels allow remote monitoring of system operation. Two types of panels are available. The SP11 (figure 76) provides system readout only. The SSP11 switching status panel (figure 77) is a combination switching subbase and system readout. The SSP11 also has an "After Hours Timer" to override the unoccupied mode (night heating setback / cooling setup).

NOTE - Status panels are not applicable to all GCS16 control systems. The following section details status panel applications.

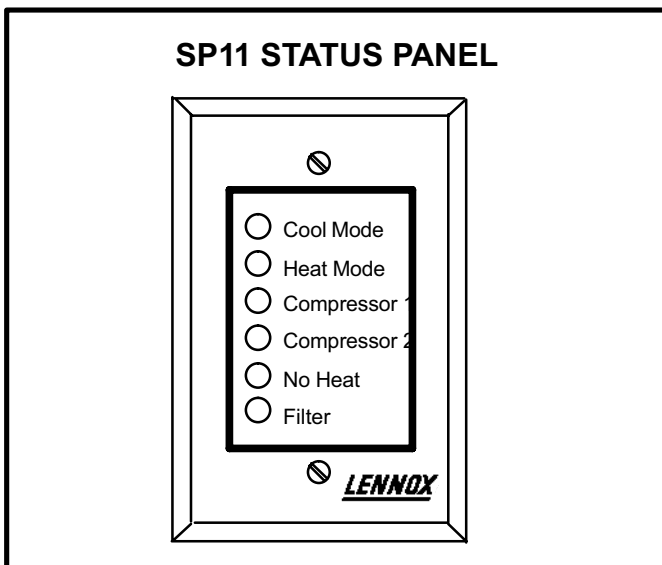

FIGURE 76

1-SP11 Application-

Required Equipment: Readout Relay Kit

Optional Equipment: Filter Switch Kit

The SP11 can be applied to all GCS16 control systems. To operate an SP11, a readout relay kit is required to interface the GCS16 to the SP11.

2-SSP11 Application-

Required Equipment with electromechanical thermostat: Readout Relay Kit

Required Equipment with W973 Control: Readout Relay Kit and SSP11 Relay Kit

Optional Equipment: Filter Switch Kit

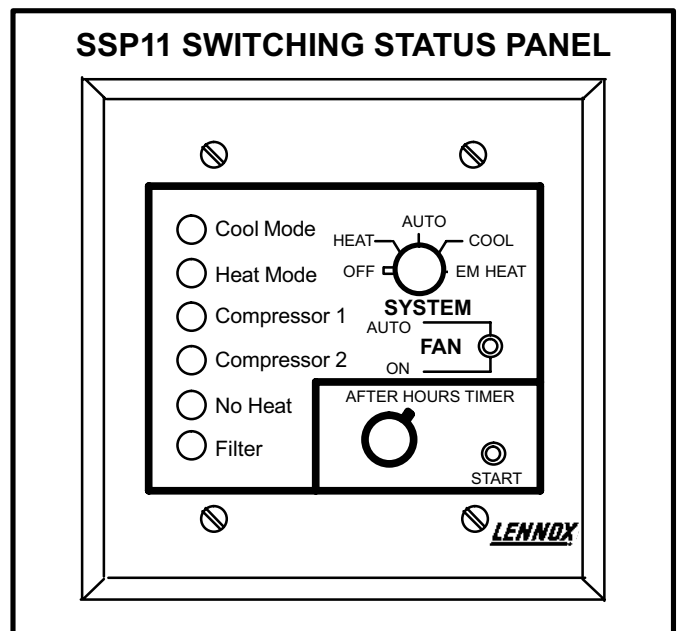

FIGURE 77

The SSP11 can be applied to GCS16s using standard electromechanical thermostat or Honeywell W973 control systems only. The Flexstat, Prostat, W7400 and T7300 control systems provide switching features similar to the SSP11, therefore, the SSP11 is not needed. To operate an SSP11, a readout relay kit is required to interface the GCS16 to the SSP11. An SSP11 relay kit is also required in units using an electromechanical thermostat.

Optional filter switch kit is required to make the dirty-filter light functional.

3-Indications and Functions

Both status panels are identical in function except for the switching and after hours capabilities of the SSP11.

- a-The “COOL MODE” LED lights green to indicate economizer “free cooling” operation when unit includes the economizer option. Otherwise, the LED indicates mechanical cooling operation.
- b-The “HEAT MODE” LED lights green during normal heating operation.
- c-The “COMPRESSOR 1” LED lights green when the compressor is running. The light turns red if a compressor safety switch opens during a compressor demand (single-phase units must be equipped with optional Controls Package for the red function of this LED to operate).
- d-The “COMPRESSOR 2” LED is not used in GCS16 210 through 650 series units.
- e-The “NO HEAT” LED lights red on a loss of heat during a heating demand.
- f- The “FILTER” LED lights red when optional filter pressure switch contacts close indicating a dirty filter.
- g-The “SYSTEM” switch on the SSP11 has five positions to indicate the following functions:
 - “OFF” - System off.
 - “HEAT” - System operates in heating mode only.
 - “AUTO” - System automatically provides heating or cooling on demand.
 - “COOL” - System operates in cooling mode only.
 - “EM HEAT” - (Emergency Heat) Not used in GCS16 units, but if placed in this position, the unit operates in the normal heating only mode.
- h-The “FAN” switch on the SSP11 has two positions to indicate the following functions:
 - “AUTO” - Blower cycles with demand.
 - “ON” - Blower runs continuously.
- i- The “AFTER HOURS TIMER” on the SSP11 provides override of unoccupied mode operation (night heating setback / cooling setup) from 0 to 12 hours. In the occupied (day) mode, the after hours timer has no effect on unit operation.

The unit must be in the unoccupied mode (night) to activate the timer. Set the potentiometer for the number of hours desired override and push the momentary start button. The unit reverts to occupied mode operation for the set number of hours.

4-Installation and Wiring

The SP11 and SSP11 require relay kits to interface the status panel to the control system and the unit. The following sections list the operation sequence and installation procedures for the relay kits and the status panels.

a-Readout Relay Kit

A readout relay kit (readout relay box - RRB) is required for all units using either the SP11 or SSP11 status panels. RRB is shown in figure 78. The RRB includes relays which interface the status panels to the unit. The status panels will not operate without the RRB.

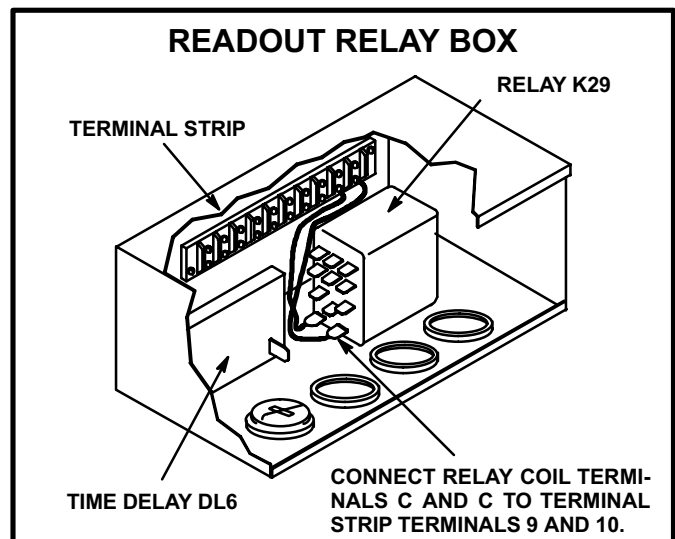

FIGURE 78

RRB Sequence of Operation:

- 1- Initial heating demand (W1) from the unit is routed through RRB terminal 2 to SP11 terminal 2 to light the green “HEAT” light.
- 2- The same heat demand is routed through RRB terminal 2 and through (RRB relay) K29 N.C. contacts to energize time delay DL6.
- 3- Time delay DL6 begins a 60-second count before closing.

- 4- After gas valve GV1 receives power, relay K29 is energized. Contacts K29-1 open and time delay DL6 resets.
- 5- If the gas valve does not receive power (indicating a problem with the ignition control or the safety circuits) before time delay DL6 finishes its 60 sec. count, time delay contacts close and red "NO HEAT" light is energized.
- 6- Other status panel lights are directly controlled by the individual unit functions.
- 7- The "COMPRESSOR" light depends on two sources of voltage for green operation and one source of voltage for red operation.

GCS16R Units:

The "COMPRESSOR" light cannot be wired to turn red. Each lead is connected to the low voltage wire between the compressor contactor coil and thermostat terminal Y1. The light will turn green to indicate compressor operation during a cooling demand.

GCS16 Units:

Each lead is connected electrically to either side of the compressor's high pressure and loss of charge switch. If the high pressure or loss of charge switch should open, the green voltage side of the "COMPRESSOR" light would drop out leaving only the red "COMPRESSOR" light on.

b-To wire an SP11 to a GCS16

- 1- Disconnect power to the unit.
- 2- Make electrical connections as shown in figure 79.

c-SSP11 Relay Kit

An SSP11 relay kit is required on units using an electromechanical thermostat and an SSP11 switching status panel. The kit is used with the RRB (readout relay kit) to interface the SSP11 to the thermostat. The SSP11 relay kit must not be used on any other control system.

SSP11 Relay Kit Sequence of Operation:

- 1-The SSP11 relay kit contains two relays which affect unit operation.
- 2- Relay K20 energizes when the SSP11 is switched to "EM HEAT." Contacts K20-1 open to de-activate the green "HEAT" light. Simultaneously, the control switch routes power backward through the "HEAT" light. The "HEAT" light changes to red. Relay K20 has no other effect on unit operation.
- 3- Relay K21 energizes when the SSP11 "FAN" switch is in the "ON" position. Contacts K21-1 switch to allow the fan to run continuously.

d-To wire an SSP11 to a GCS16

- 1- Disconnect power to the unit.
- 2- Make electrical connections as shown in figures 80 and 81.

5-Filter Switch Kit

An air filter switch kit is available for use with the SP11 and SSP11. The air filter switch is activated by high negative pressure in the blower compartment caused by dirty air filters or other restrictions. When high negative pressure causes the switch to close, power is routed from terminal strip terminal TB1-6 through the switch to the red "FILTER" light in the SP11 or SSP11. See figure 82.

FIELD WIRING SP11 GCS16-410 THROUGH -650

(applicable to units equipped with commercial controls only)

NOTE-This diagram shows field wiring connections made IN ADDITION TO thermostat field wiring. Thermostat field wiring is not shown.

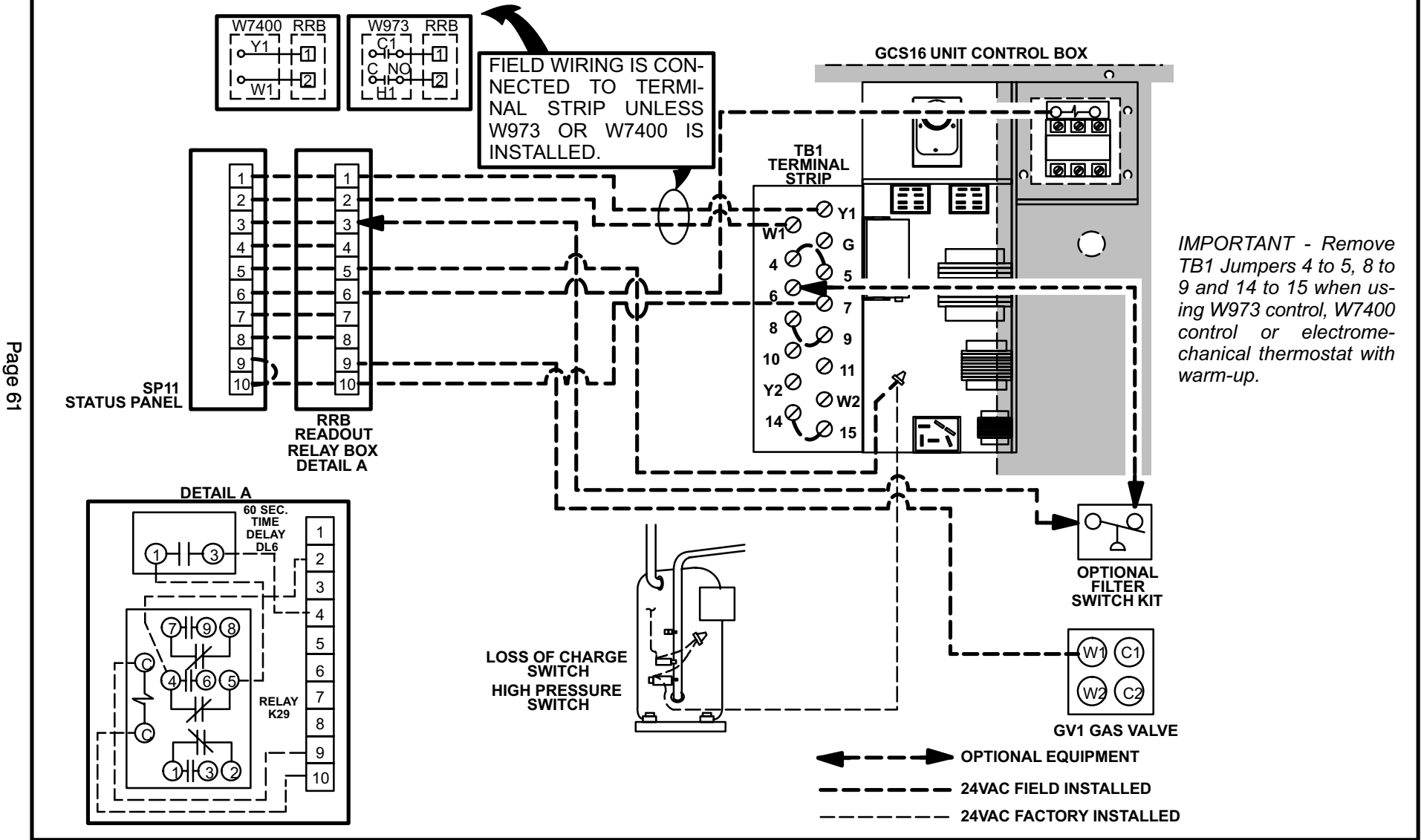

FIGURE 79

FIELD WIRING SSP11
GCS16-410 THROUGH -650 UNITS WITH ELECTROMECHANICAL THERMOSTAT
C1 or C2 THERMOSTAT CONTROL SECTION INSTALLED
 (applicable to units equipped with commercial controls platform only)

NOTE-This diagram shows field wiring connections made IN ADDITION TO thermostat field wiring. Thermostat field wiring is not shown.

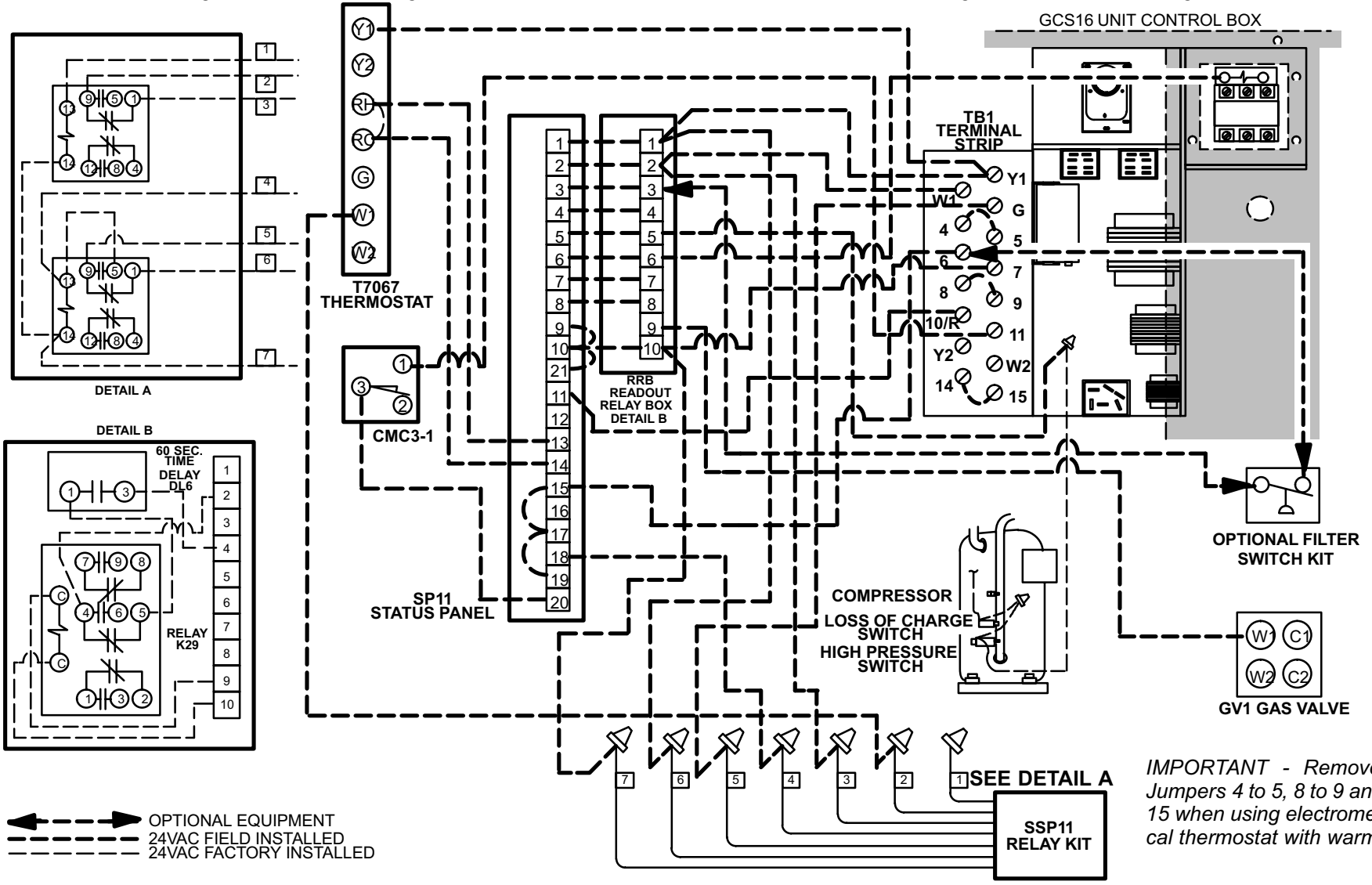

FIGURE 80

FIELD WIRING SSP11
GCS16-410 THROUGH -650 UNITS WITH W973
C8 or C14 THERMOSTAT CONTROL SECTION INSTALLED
 (applicable to units equipped with commercial controls platform only)

NOTE-This diagram shows field wiring connections made IN ADDITION TO thermostat field wiring. Thermostat field wiring is not shown.

IMPORTANT - Remove TB1 Jumpers 4 to 5, 8 to 9 and 14 to 15.

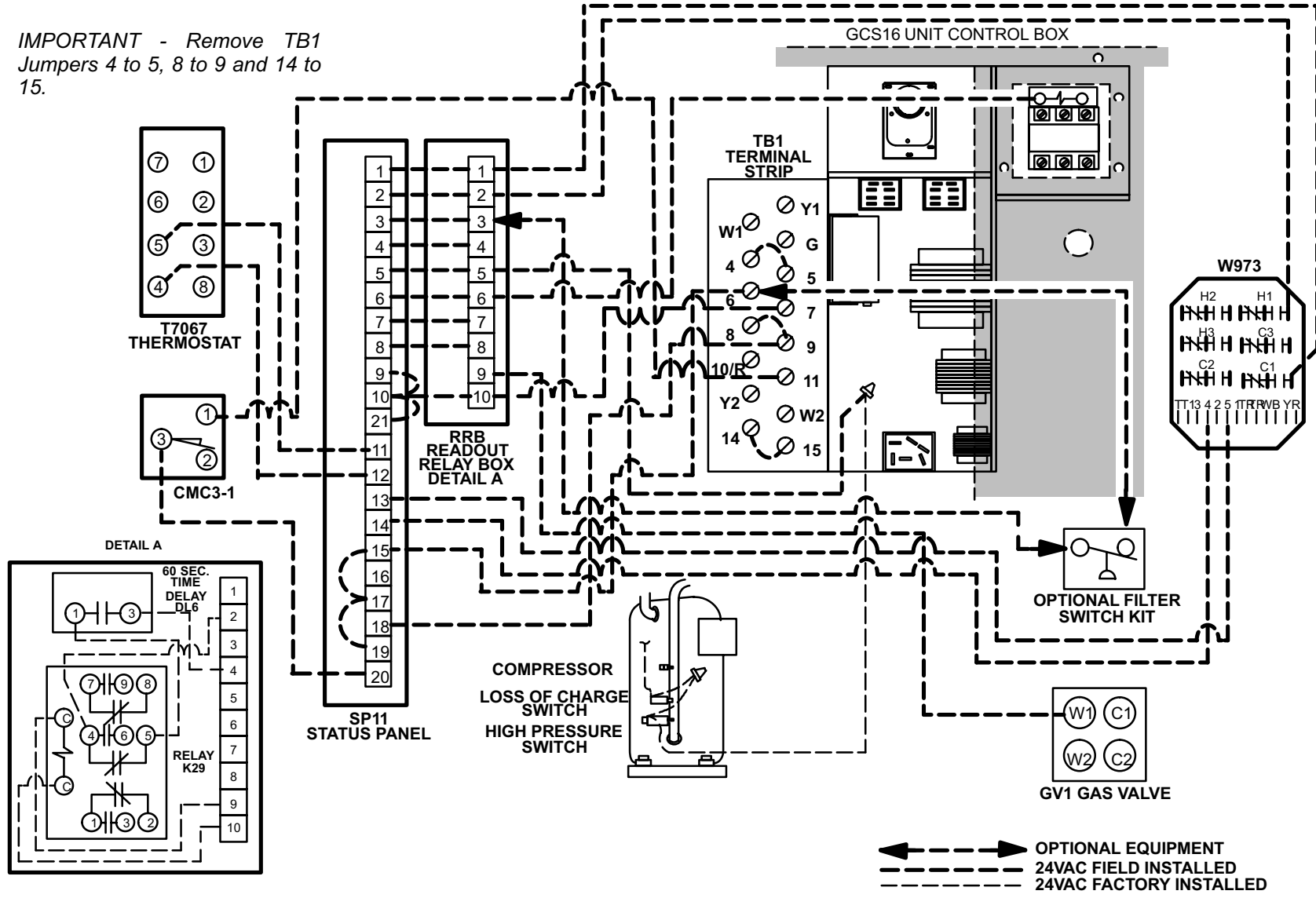

FIGURE 81

TYPICAL FILTER SWITCH INSTALLATION

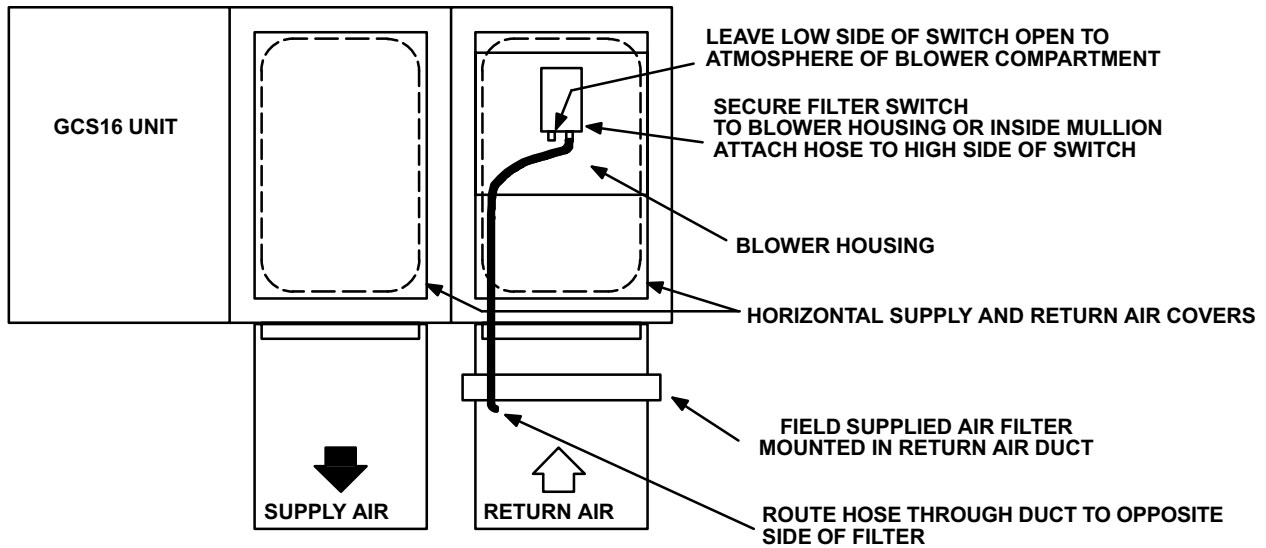

FIGURE 82

S-Commercial Controls Hardware (GCS16 Commercial Units Only)

All GCS16 commercial units (GCS16R and GCS16H excluded) are factory equipped with the hardware required to connect and operate Lennox' Commercial Controls (W973, W7400, economizer, warm-up, etc...). The hardware consists of an economizer wiring harness (figure 83), low voltage terminal strip, discharge line high pressure, loss of charge switches and crankcase heater. The switches, crankcase heater and terminal strip are detailed in the unit components section of this manual. The economizer harness is a pre-wired harness which facilitates economizer, controls and/or warm-up connections.

T-Optional Commercial Controls Systems

Optional "16 Series Commercial Controls" may be connected to all GCS16 commercial units (GCS16R and GCS16H excluded). These are the same controls which are optional to larger GCS16 commercial units. The following list describes the components used in all currently available (at time of printing) optional control system combinations. Each system is assigned a "C" number for easy reference. The "C" number identifies the control system on the wiring diagram (likewise, each GCS16 unit wiring diagram is assigned a "B" number and each economizer diagram is assigned a "D" number).

The following section is provided to help service personnel become familiar with Lennox' Commercial Controls and the associated wiring schemes.

1- D5 - Modulating Economizer

Horizontal or Downflow Modulating Economizer. Optional field installed in all GCS16 and GCS16H units (GCS16R excepted). Sensors continuously monitor air conditions and adjust dampers accordingly. Infinite number of damper positions.

2- D8 - Three Position Economizer

Horizontal or Downflow Three Position Economizer. Optional field installed in all GCS16 and GCS16H units (GCS16R excepted). Sensors continuously monitor air conditions and adjust dampers to one of three positions: closed, mid (minimum) or full open.

NOTE - Even though horizontal and downflow economizers are physically different, they are electrically identical and therefore, share the same wiring diagram and "D" number.

NOTE - D5 and D8 economizers require night relay (K11) if night setback is desired with electromechanical thermostat or W973 control system. Field wiring is shown in the economizer section of this manual.

3- Warm-Up Kit

Warm-up kit is shown in Figure 84. Warm-up kit is an accessory to economizer (D5 or D8). The kit provides warm-up capabilities by holding outdoor air dampers closed during the first heating period after night setback. When first heating demand is satisfied, warm-up kit allows outdoor air dampers to open to minimum position.

Warm-up kit does not have its own wiring diagram. It is included in the C2, C4, C6 and C14 wiring diagrams.

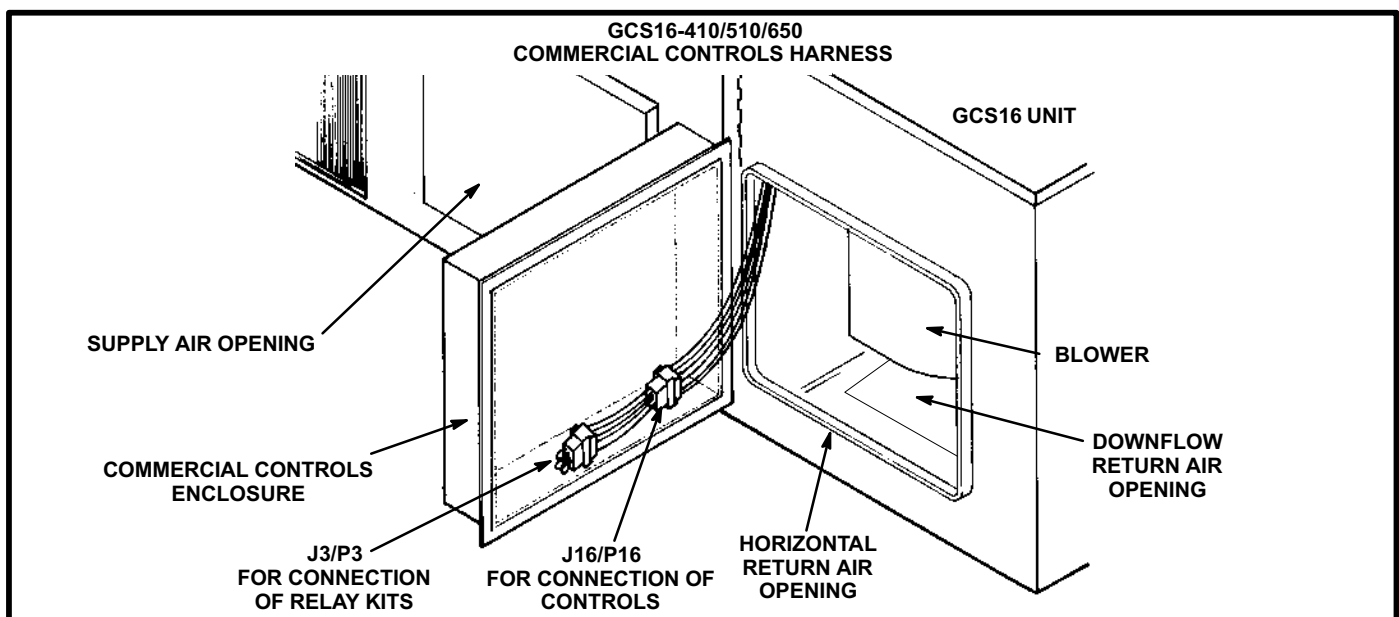

FIGURE 83

Some of the following optional thermostat control systems have built-in warm up capabilities and the warm up kit shown in figure 84 cannot be added due to wiring incompatibility.

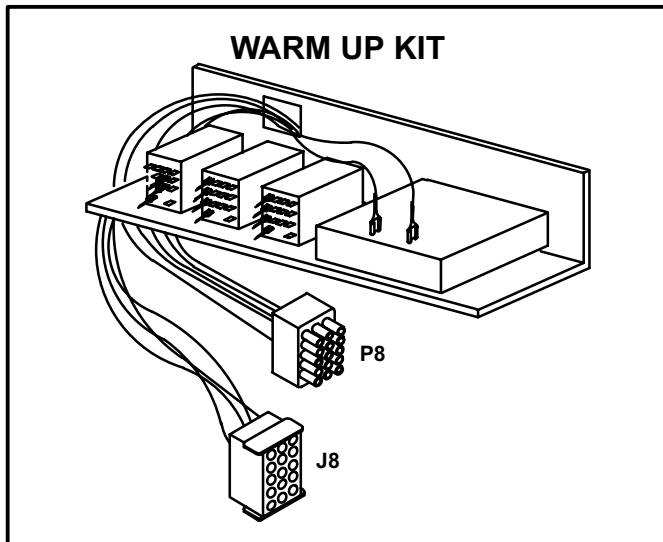

FIGURE 84

- 4- C24 -- Standard heat/cool thermostat for single-phase residential GCS16R and GCS16H. Optional controls cannot be used. Thermostat is hard wired to unit (terminal strip not provided).
- 5- C19 -- Special limited application of commercial (electromechanical or electronic) thermostat and D5 or D8 economizer to single-phase GCS16H. Economizer harness (shown as a part of C19 wiring diagram) is provided in required RDE16-41 transition. Harness provides J3 jack for connecting economizer. Harness hard wires to unit and thermostat with pig-tails (no terminal strip provided). Night thermostat and CMC3-1 clock must be added for night setback. Night relay must also be added to economizer for night setback.
- 6- C1-1 -- Standard 2 heat / 2 cool thermostat for all commercial units without economizer or warm-up.
- 7- C1-2 -- Standard 2 heat / 2 cool thermostat for all commercial units with economizer but without warm-up. CMC3-1 clock and night thermostat must be added for night setback. Night relay must also be added to economizer for night setback.

- 8- C2
Standard 2 heat / 2 cool thermostat for all commercial units with economizer and warm-up. CMC3-1 clock and night thermostat must be added for night setback. Night relay must also be added to economizer for night setback.
- 9- C11-1 -- Standard 2heat/2cool thermostat for all commercial units without economizer or warm-up. C11 Night Kit adds a relay facilitating night setback function (see figure 85). CMC3-1 clock and night thermostat must also be added to make setback relay functional.

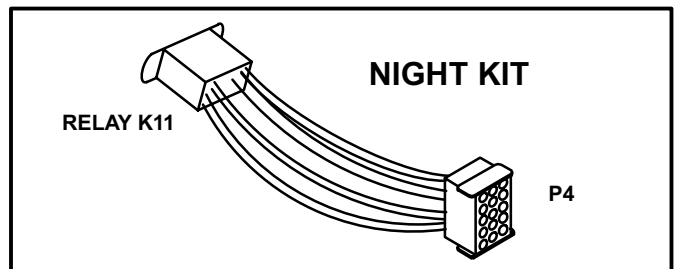

FIGURE 85

- NOTE - Flexstat (C3 and C4 diagrams) was discontinued as a control system option in July 1989 and is not shown in the GCS16 (2-5 ton) promotional material. However, Flexstat remains a valid matchup to commercial GCS16s of all sizes until inventories are depleted. You may find some (2-5 ton) units using it.*
- 10-C3-1 -- Flexstat L2F-N for commercial units without economizer or warm-up. Setback is built in.
 - 11-C3-2 -- Flexstat L2F-N for commercial units with economizer but without warm-up. Setback is built in.
 - 12-C4-1 -- Flexstat L2F-N for commercial units with economizer and warm-up. Setback is built in.
 - 13-C5-1 -- Prostat L2F-N for commercial units without economizer or warm-up. Setback is built in.
 - 14-C5-2 -- Prostat L2F-N for commercial units with economizer but without warm-up. Setback is built in.
 - 15-C6-1 -- Prostat L2F-N for commercial units with economizer and warm-up. Setback is built in.

16-C7 – W7400 control system for commercial units without economizer. Setback is built in. See Figure 86.

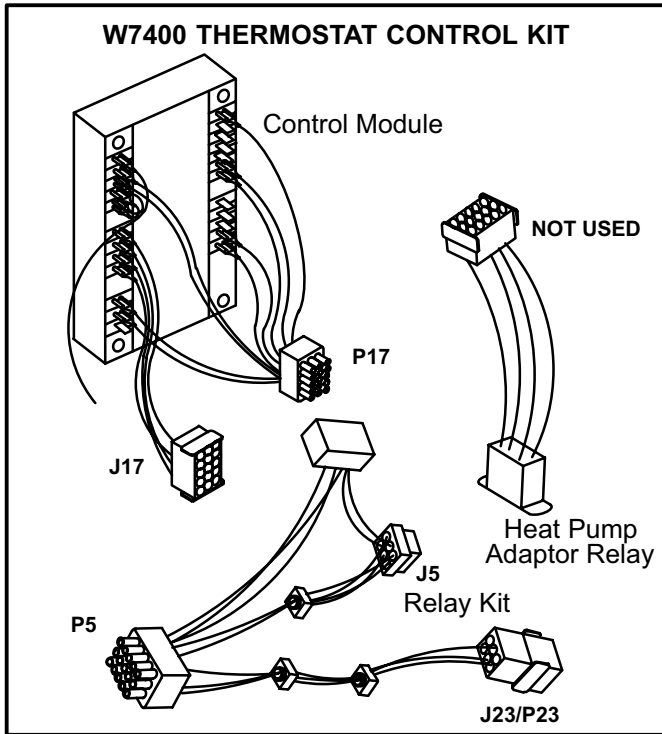

FIGURE 86

17-C7-3 -- W7400 control system for commercial units. Requires W7400 relay kit and economizer. Warm-up and setback are built in.

18-C8-1 -- W973 control system for commercial units without economizer or warm-up. See figure 87. Requires W973 relay kit. Also requires CMC3-1 clock for night setback.

19-C8-3 -- W973 control system for commercial units with economizer but without warm-up. Requires W973 relay kit. Also requires CMC3-1 clock and night relay for night setback.

20-C14-1 -- W973 control system for commercial units with economizer and warm-up. Requires W973 relay kit. Also requires CMC3-1 clock and night relay for night setback.

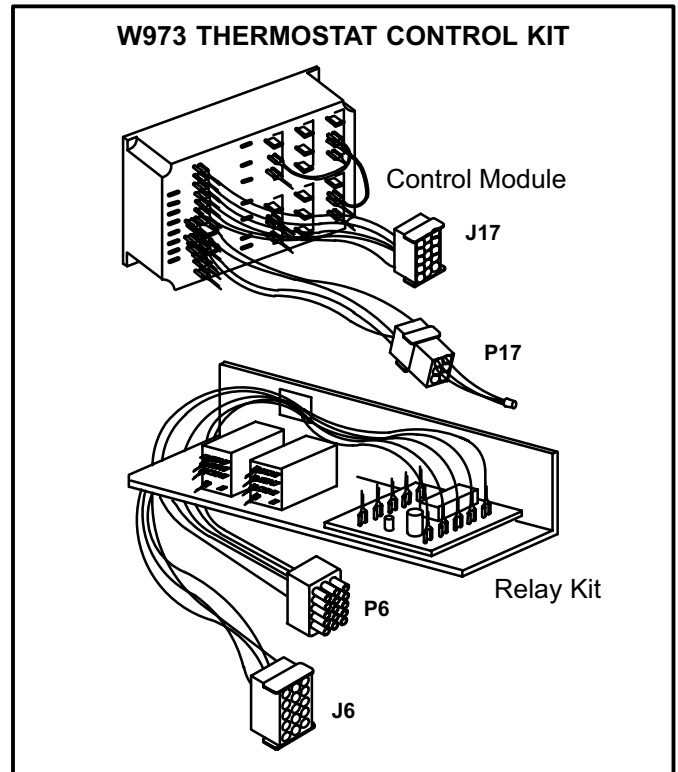

FIGURE 87

21-C12-1 -- T7300 electronic thermostat for commercial units without economizer.

22-C12-2 -- T7300 electronic thermostat for commercial units with economizer. Warm-up is built in.

U-Commercial Controls Mounting Box Commercial Controls Mounting Bracket

The commercial controls box and bracket provide a mounting location for GCS16 commercial controls. Figure 83 shows the mounting box. The box is designed for use with GCS16s in downflow return applications. The box utilizes the horizontal air opening for this purpose. Figure 88 shows how the box is installed on the GCS16. The bracket (shown in figure 89) is designed for use with GCS16s in horizontal return applications. The bracket utilizes the downflow opening for this purpose.

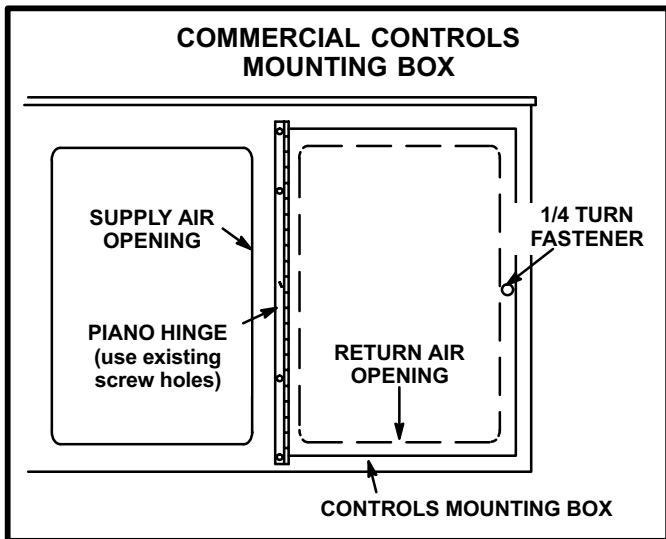

FIGURE 88

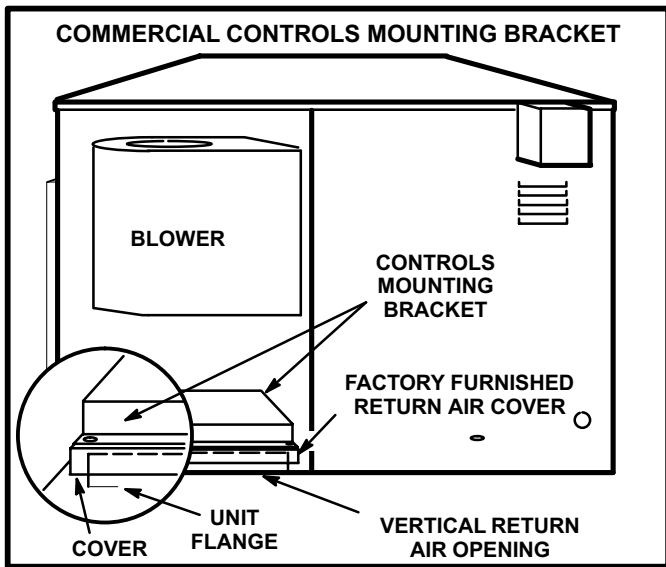

FIGURE 89

a

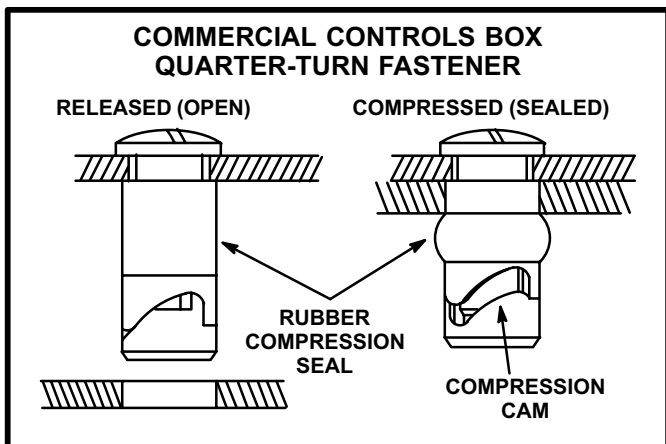

FIGURE 90

The box is fully insulated and a gasket around the enclosure flange provides an airtight seal. When servicing the controls or blower, make sure the seal and insulation are in good condition and make sure the seal is making an airtight connection with the cabinet. The controls box is fastened to the cabinet with a quarter-turn fastener. The fastener seals with a rubber ring which compresses around the inside of the opening to provide an airtight seal. Figure 90 shows the quarter-turn fastener.

V-Clocks / Timers (CMC3-1)

Two optional clocks (both designated model# CMC3-1) are available for use with either the electromechanical thermostat or the Honeywell W973 control system. Both allow mechanical thermostats to set back during unoccupied periods. The clocks, models 202A and 702A, allow 24-hour and 7-day programmability, respectively.

Other GCS16 control system options (W7400, T7300, Pro-stat, etc.) are equipped with built-in clocks for this purpose and do not need CMC3-1.

Both CMC3-1 clocks are alike except for programmability. The clocks are rated 24VAC*, 60Hz and have SPDT contacts rated at 15A and 120VAC.

**NOTE - Some clocks may be 120VAC while most are 24VAC. Be sure to check clock motor rating and wire clock according to its rating.*

Wiring connections should be made to N.O. terminal 1 and 3 (see figure 91). Refer to the sequence of operation for the control system being used (back of this manual) for correct wiring connections. Refer to the "Status Panel" section of this manual for wiring connections of clocks used with SP11 or SSP11. Refer to the manufacturer's operation and installation instructions printed inside the front cover of each clock.

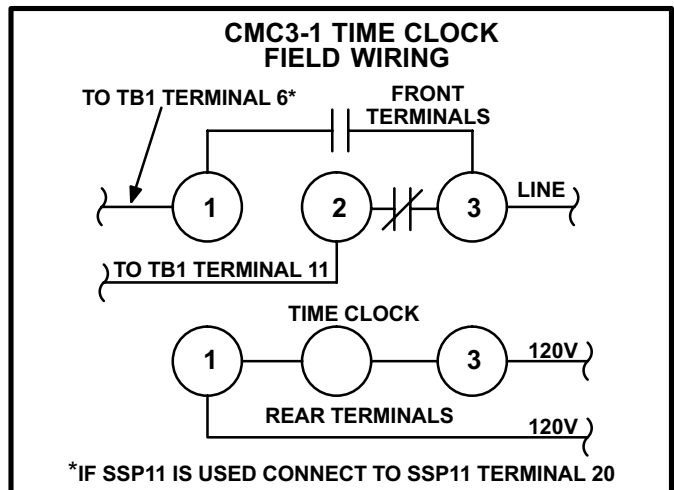

*IF SSP11 IS USED CONNECT TO SSP11 TERMINAL 20

FIGURE 91

XII-COMMERCIAL CONTROLS INSTALLATION OF PLUG-IN KITS (Figure 92)

The commercial controls harness allows optional commercial controls and economizer to plug in to the GCS16 so field wiring is minimized. Figure 92 shows the commercial controls harness which is located in the GCS16 blower compartment. GCS16H and GCS16R units are not equipped with commercial controls harness.

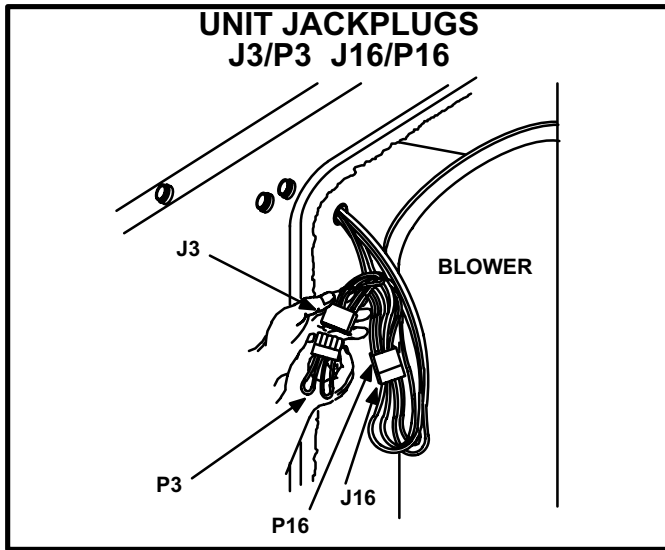

FIGURE 92

A-Night Kit

The night kit is used only with the C11 control system option. It cannot be used with any other control system options or control damage will result. This system is designed for use with optional CMC3-1 time clock and night thermostat.

Optional night (setback relay) kit allows GCS16 units without economizer (REMD16 or EMDH16) to automatically set back the thermostat to reduce energy consumption during times when the building is not occupied. The night kit achieves this by disconnecting thermostat S1 and con-

necting a night thermostat during periods when the building is not occupied. The night thermostat can then be adjusted with a lower setpoint as needed for unoccupied heating.

WARNING - CONNECT ONLY RELAY KITS DESIGNED FOR THIS CONTROL SYSTEM. RELAY KITS DESIGNED FOR OTHER CONTROL SYSTEMS ARE NOT COMPATIBLE AND CONTROL DAMAGE OR FAILURE WILL RESULT. FOR EXAMPLE, DO NOT CONNECT A WARM-UP KIT TO THIS CONTROL SYSTEM.

No wiring is required (see figure 93). Jumper-plug P3 is removed and discarded. Night kit harness plug P4 connects directly into economizer harness jack J3.

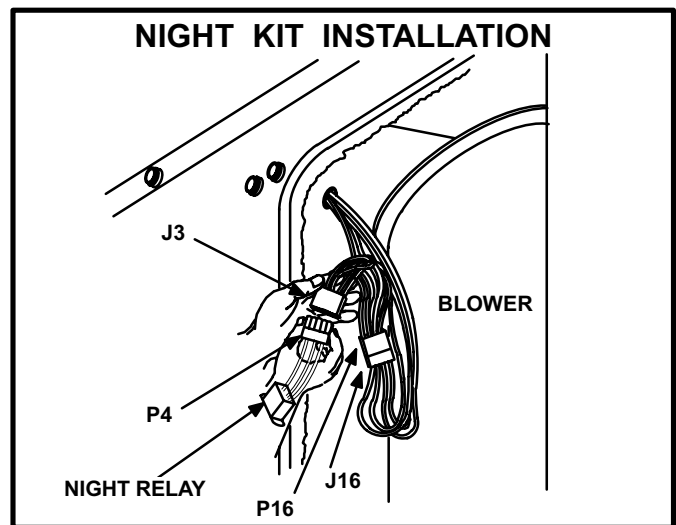

FIGURE 93

B-Night Relay

D5 (modulating) and D8 (three-position) economizers require a field-installed night relay (same function as night kit) when used with electromechanical thermostat or W973 and night setback is required. The relay is a field-installed option which is hard-wired to the economizer (pigtails not supplied). The relay is field wired.

C-W7400 Control System

The W7400 is used only with the C7 control system option. It cannot be used with any other control system option or control damage will result.

The Honeywell W7400/T7400 control system, when applied to the GCS16, allows fully programmable operation of the unit during occupied and unoccupied periods. Morning warm-up capabilities are built in to the control system. An external warm-up kit is not needed.

1-W7400 Control

No wiring is required (see figure 94). Disconnect Jumper J16 from plug P16. Connect W7400 plug P17 to unit jack J16. Connect W7400 jack J17 to unit plug P16.

For basic unit operation without economizer, unit plug P3 must be connected to unit jack J3.

2-W7400 Relay Kit

An economizer may be added to the system to allow out-

side air for cooling. W7400 relay kit must be added to interface the control to the economizer.

WARNING - CONNECT ONLY RELAY KITS DESIGNED FOR THIS CONTROL SYSTEM. RELAY KITS DESIGNED FOR OTHER CONTROL SYSTEMS ARE NOT COMPATIBLE AND CONTROL DAMAGE OR FAILURE WILL RESULT. FOR EXAMPLE, DO NOT CONNECT A W973 RELAY KIT TO THIS CONTROL SYSTEM.

CAUTION - DO NOT CONNECT A WARM-UP KIT TO JACK J5 OF THE W7400 RELAY KIT. Warm-up kit wiring is not compatible with W7400 wiring and COMPONENT DAMAGE WILL RESULT. The W7400 system has a warm-up feature built in. A warm-up kit is not needed.

No wiring is required (see figure 95). Unit plug P3 is removed and discarded. Relay kit plug P5 connects to unit jack J3. Economizer plug P4 connects to relay kit jack J5.

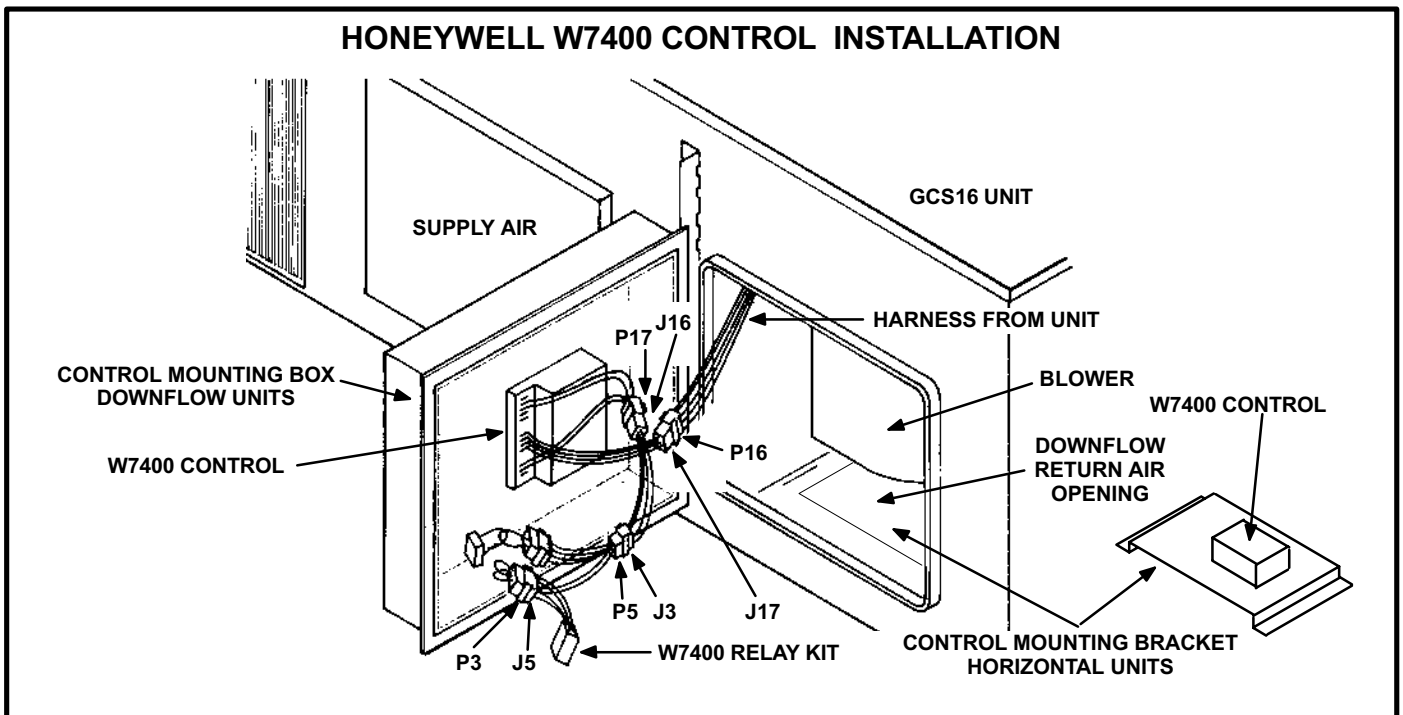

FIGURE 94

HONEYWELL W7400 INSTALLATION WITH ECONOMIZER

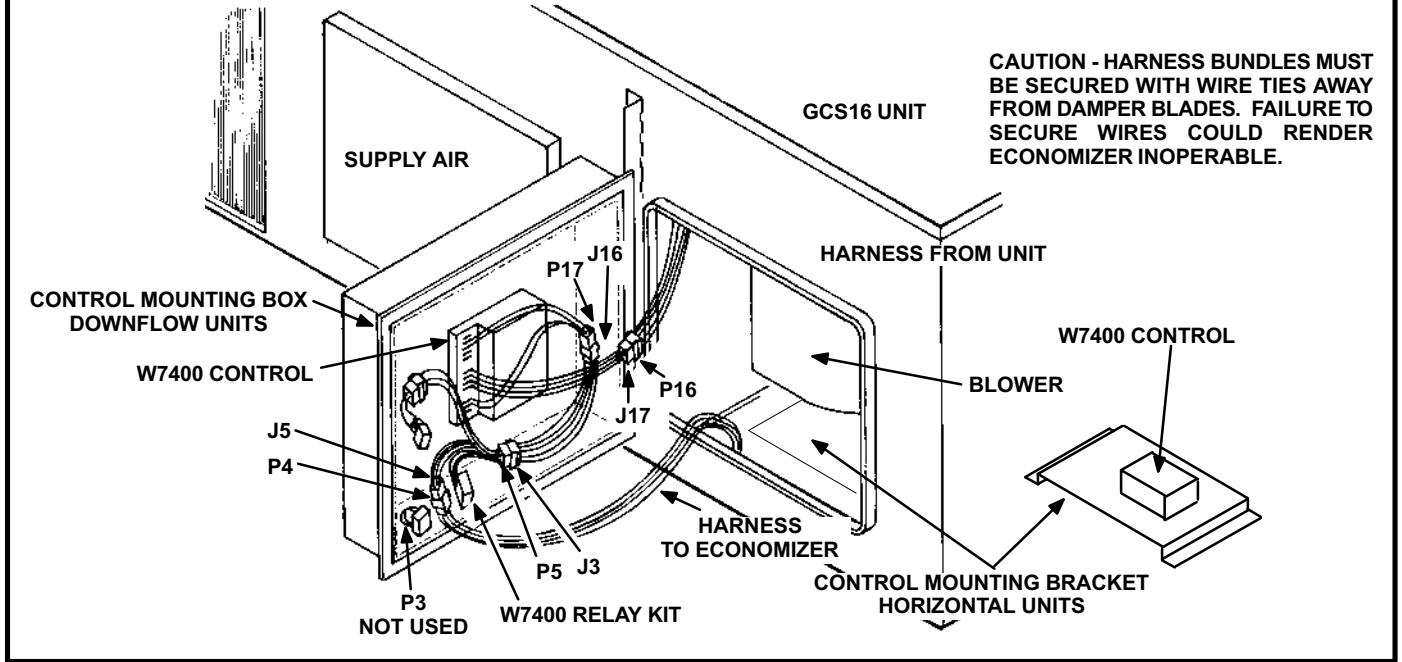

FIGURE 95

WARM UP KIT RELAY KIT INSTALLATION

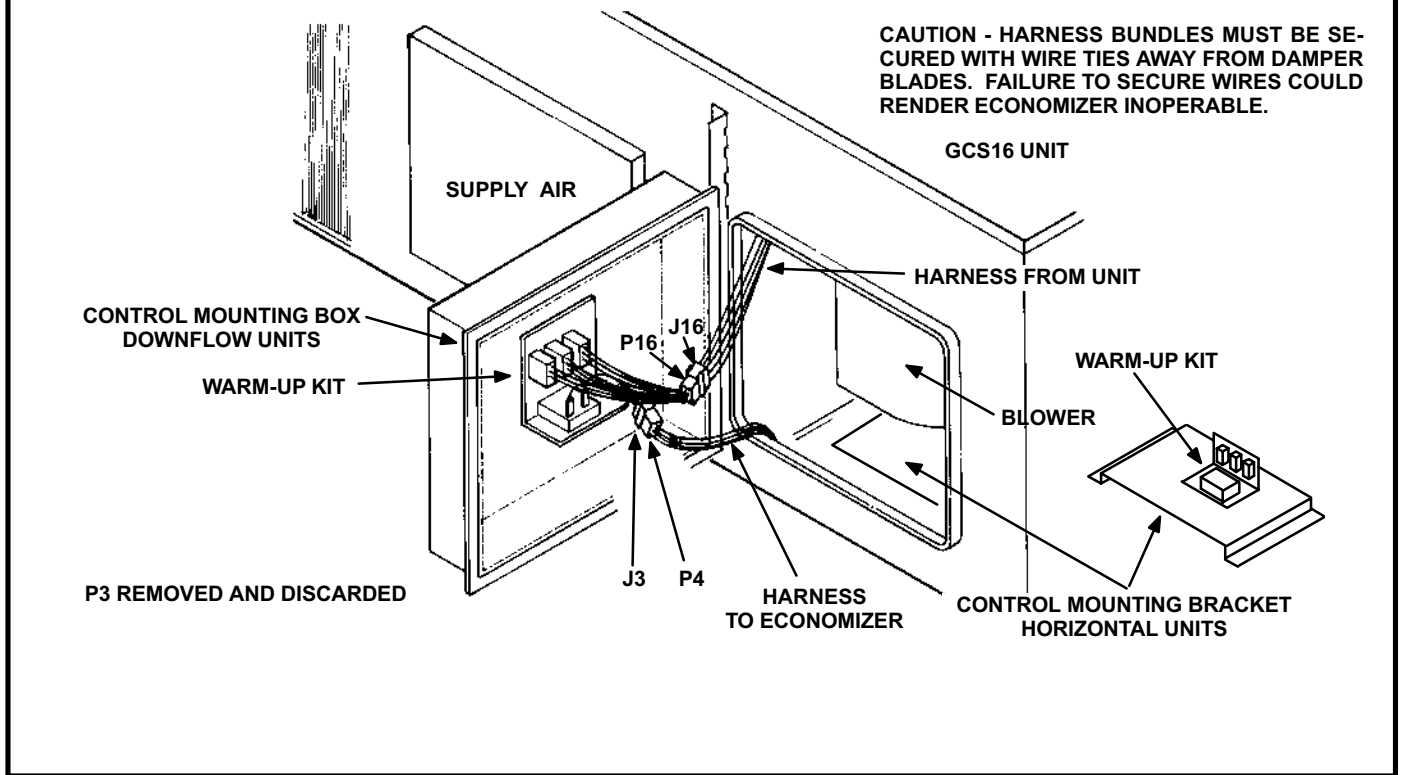

FIGURE 96

D-Warm-Up Kit

The warm-up kit is an option to the REMD16 and EMDH16 economizers. The warm-up kit may be applied to any economizer (except units using W7400 control system or T7300 control system). If W973 control system is being used, CMC3-1 time clock must also be used. If electromechanical control system is being used, CMC3-1 time clock and night thermostat must be used.

An economizer allows outside air to be used for cooling when conditions are acceptable and permits a preset amount of air exchange during all other unit operation. Warm-up kit holds outdoor air dampers full closed during

first heating demand after night setback (during morning warm-up).

CAUTION - DO NOT CONNECT A WARM-UP KIT TO A W7400 RELAY KIT OR TO A SYSTEM USING A T7300. Warm-up kit wiring is not compatible with these control systems and COMPONENT DAMAGE WILL RESULT. These control systems have a warm-up feature built in. A warm-up kit is not needed.

No wiring is required (see figure 96). The kit plugs into the unit wiring harness between the unit and economizer. Unit plug P3 is removed and discarded. Relay kit plug P8 connects to unit jack J3. Relay kit jack J8 connects to economizer plug P4.

E-W973 Control System

The W973 is used only with the C8 and C14 control system options. It cannot be used with any other control system options or control damage will result.

The Honeywell W973 control, when added to the GCS16, allows the use of electronic ramping thermostats, discharge temperature sensors, return air temperature sensors and/or remote thermostats and transmitters. The W973 control system is designed for use with Honeywell T7067 electronic ramping thermostat and Q667 subbase.

An interconnecting W973 relay kit must be used to adapt the W973 to the GCS16. Optional CMC3-1 time clock must also be used for night setback capabilities. The relay kit changes the thermostat setpoints for night setback. A night thermostat is not needed.

1-W973 Control (C8 and C14 control systems)

No wiring is required (see figure 97). Disconnect Jumper J16 from plug P16. Connect W973 plug P17 to unit jack J16. Connect W973 jack J17 to unit plug P16. Jumper plug J19 supplied with the W973 must

be connected to plug P19 on the W973. Jumper plug J12 (also supplied with the W973) is not used with GCS16s and may be discarded.

2-W973 Relay Kit units without economizer or units with economizer and without warm-up (C8-1 and C8-3 control systems)

No wiring is required (see figure 98). Disconnect unit plug P3 from unit jack J3 *but do not discard*. Plug P3 must be used if unit is not equipped with economizer. Connect relay kit plug P6 to unit jack J3.

If unit is not equipped with economizer, connect relay kit J6 to unit plug P3.

If unit is equipped with economizer, connect relay kit plug P6 to economizer jack J4.

3-W973 Relay Kit with Warm-Up units with economizer and warm-up (C14-1 control system)

No wiring is required (see figure 99). Unit plug P3 is removed from unit and discarded. Connect W973 relay kit plug P6 to unit jack J3. Connect W973 relay kit jack J6 to warm-up kit plug P8. Connect warm-up kit jack J8 to economizer plug P4.

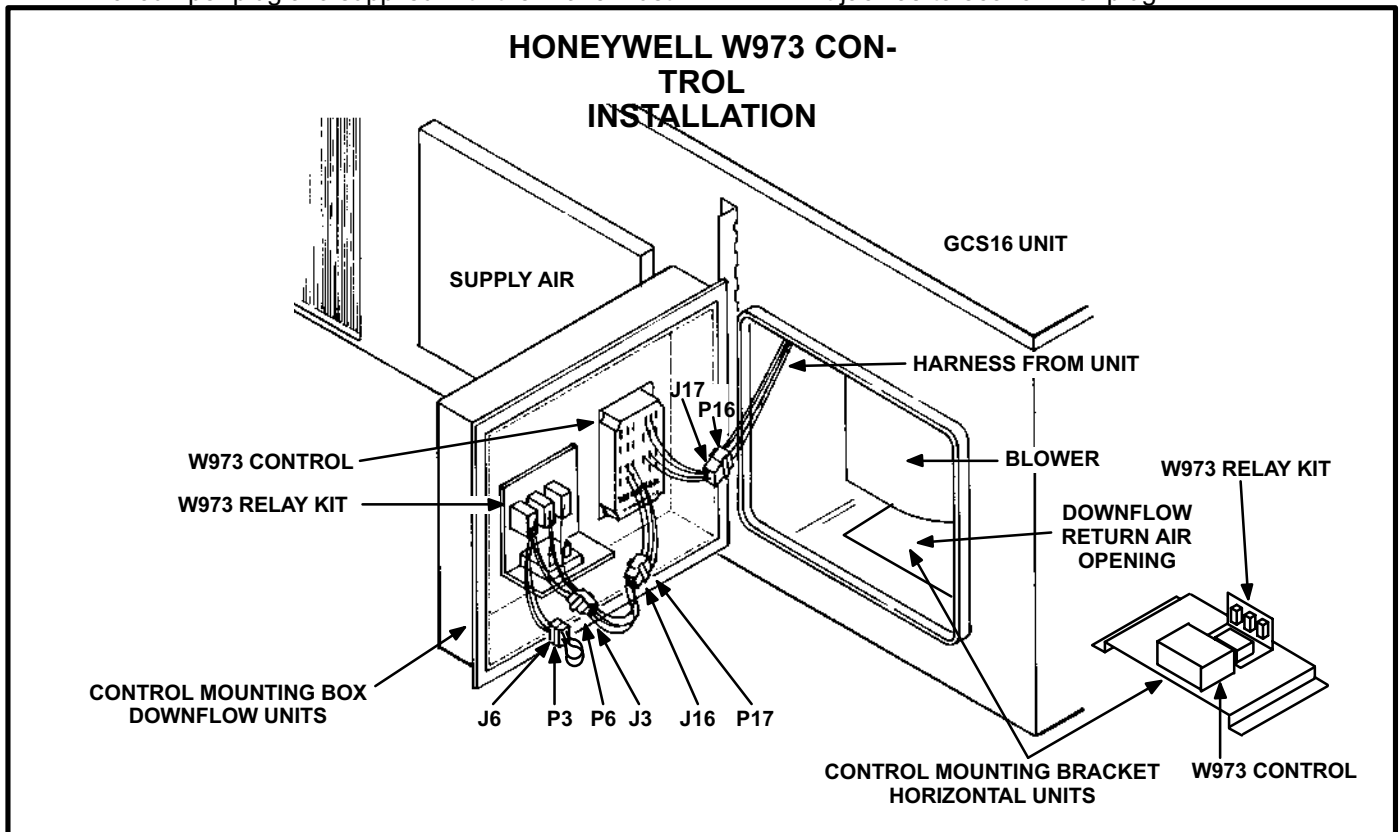

FIGURE 97

HONEYWELL W973 CONTROL INSTALLATION with ECONOMIZER

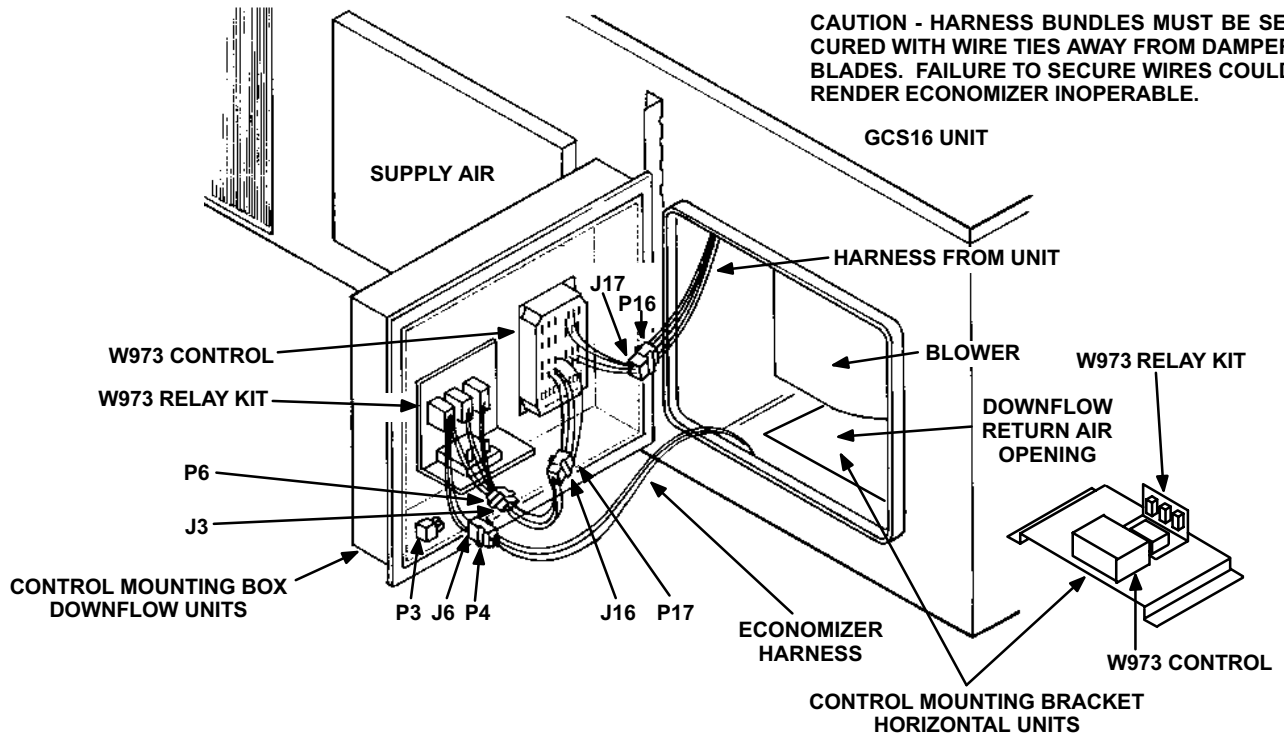

FIGURE 98

HONEYWELL W973 RELAY KIT AND WARM UP KIT INSTALLATION

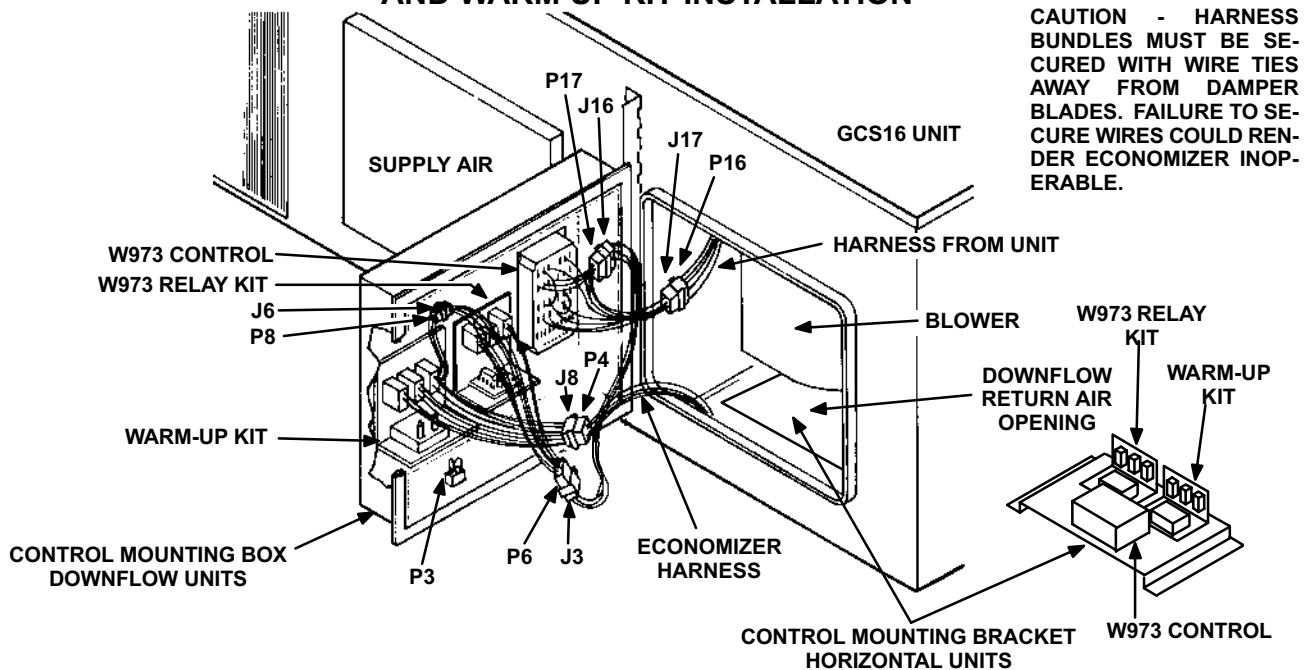

FIGURE 99

XIII-WIRING DIAGRAMS AND OPERATION SEQUENCE

The following section shows the wiring diagrams for all units and all possible control systems. An operation sequence is provided with each diagram.

How the diagrams are organized

The operation sequence of each unit is unique and independent of the control system. For example, a GCS16-651-125 unit proceeds through a set operation sequence after receiving a cooling demand regardless of which thermostat control systems is installed.

Likewise, the operation sequence of each control system is independent of the unit it is connected to. For example, a W973 control processes a cooling demand in a set way regardless of whether it is connected to a single-phase, three-phase, single-stage or two-stage unit.

To simplify this section of the manual, the operation sequence of each unit is shown connected only to the simplest thermostat control (C1 - electromechanical thermostat). For instructional purposes, this allows the instructor or student to concentrate on basic unit operation.

Operation sequence of the optional control systems can be complex and more difficult to understand. For this reason, the unit diagram was omitted from the optional control system diagrams in order to concentrate on basic control system operation.

Why the diagrams are organized this way

It is important to remember, however, that it is not necessary to see the control system diagram and unit diagram connected together in order to understand the operation sequence or to troubleshoot the unit. This concept is easier to see once it is understood that the control system (operation sequence) and unit (operation sequence) are independent.

A complete diagram including the unit diagram, control system diagram and unit accessory diagrams, can be found stuck to the inside face of the unit control box access panel. The diagrams should be affixed by the installer in a manner that will allow the diagrams to be read in their complete form.

WIRING DIAGRAM INDEX	
Introduction	Page 75
A- RESIDENTIAL THERMOSTAT SYSTEMS and RESIDENTIAL UNITS	Pages 76-81
Basic Thermostat GCS16R and GCS16H C24 Diagram with B34 Diagram	Pages 76-77
Commercial Application GCS16H and 3-position Economizer C19 Diagram with B34 Diagram and D8 Diagram ..	Pages 78-79
Commercial Application GCS16H and Modulating Economizer C19 Diagram with B34 Diagram and D5 Diagram ..	Pages 80-81
B- COMMERCIAL THERMOSTAT SYSTEMS and COMMERCIAL UNITS	Pages 82-96
Single Phase Unit with Electromechanical Thermostat C1 Diagram with B34 Diagram	Pages 82-83
Three Phase Units with Electromechanical Thermostat C1 Diagram with B35 or B36 Diagram	Pages 84-86
Electromechanical Thermostat with 3-position Economizer C1 Diagram with D8 Diagram	Pages 87-88
Electromechanical Thermostat with Modulating Economizer C1 Diagram with D5 Diagram	Pages 89-90
Electromechanical Thermostat, 3-position Econ. and Warm-up C2-1 Diagram with D8 Diagram	Pages 91-92
Electromechanical Thermostat, Modulating Econ. and Warm-up C2-1 Diagram with D5 Diagram	Pages 93-94
Electromechanical Thermostat with Night-Kit C11-1 Diagram	Pages 95-96
C- COMMERCIAL ELECTRONIC THERMOSTATS ..	Pages 97-116
Flexstat and Prostat C3 Diagram / C5 Diagram	Pages 97-98
Flexstat and Prostat with 3-position Economizer C3 or C5 Diagram with D8 Diagram	Pages 99-101
Flexstat and Prostat with Modulating Economizer C3 or C5 Diagram with D5 Diagram	Pages 102-104
Flexstat/Prostat, 3-position Economizer and Warm-up C4 or C6 Diagram with D8 Diagram	Pages 105-107
Flexstat/Prostat, Modulating Economizer and Warm-up C4 or C6 Diagram with D5 Diagram	Pages 108-110
Honeywell T7300 C12 Diagram	Pages 111-112
Honeywell T7300 with 3-position Economizer C12 Diagram with D8 Diagram	Pages 113-114
Honeywell T7300 with Modulating Economizer C12 Diagram with D5 Diagram	Pages 115-116
D- HONEYWELL W7400 CONTROL SYSTEM	Pages 117-120
W7400 Control with 3-position Economizer C7-3 Diagram with D8 Diagram	Pages 117-118
W7400 Control with Modulating Economizer C7-3 Diagram with D5 Diagram	Pages 119-120
E- HONEYWELL W973 CONTROL SYSTEM	Pages 121-134
W973 Control C8-1 Diagram	Pages 121-122
W973 Control with 3-position Economizer C8-1 Diagram with D8 Diagram	Pages 123-125
W973 Control with Modulating Economizer C8-1 Diagram with D5 Diagram	Pages 126-128
W973 Control and 3-position Economizer with Warm-up C14-1 Diagram with D8 Diagram	Pages 129-131
W973 Control and Modulating Economizer with Warm-up C14-1 Diagram with D5 Diagram	Pages 132-134

C24 diagram with B34 diagram basic thermostat with residential GCS16R or GCS16H

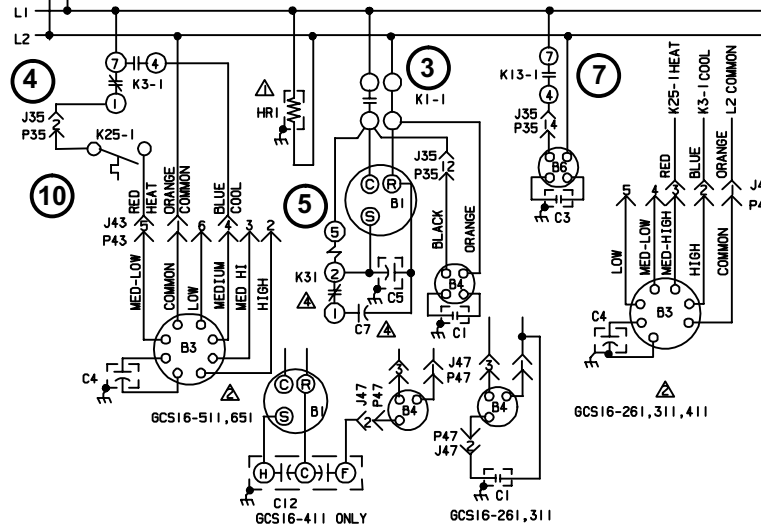
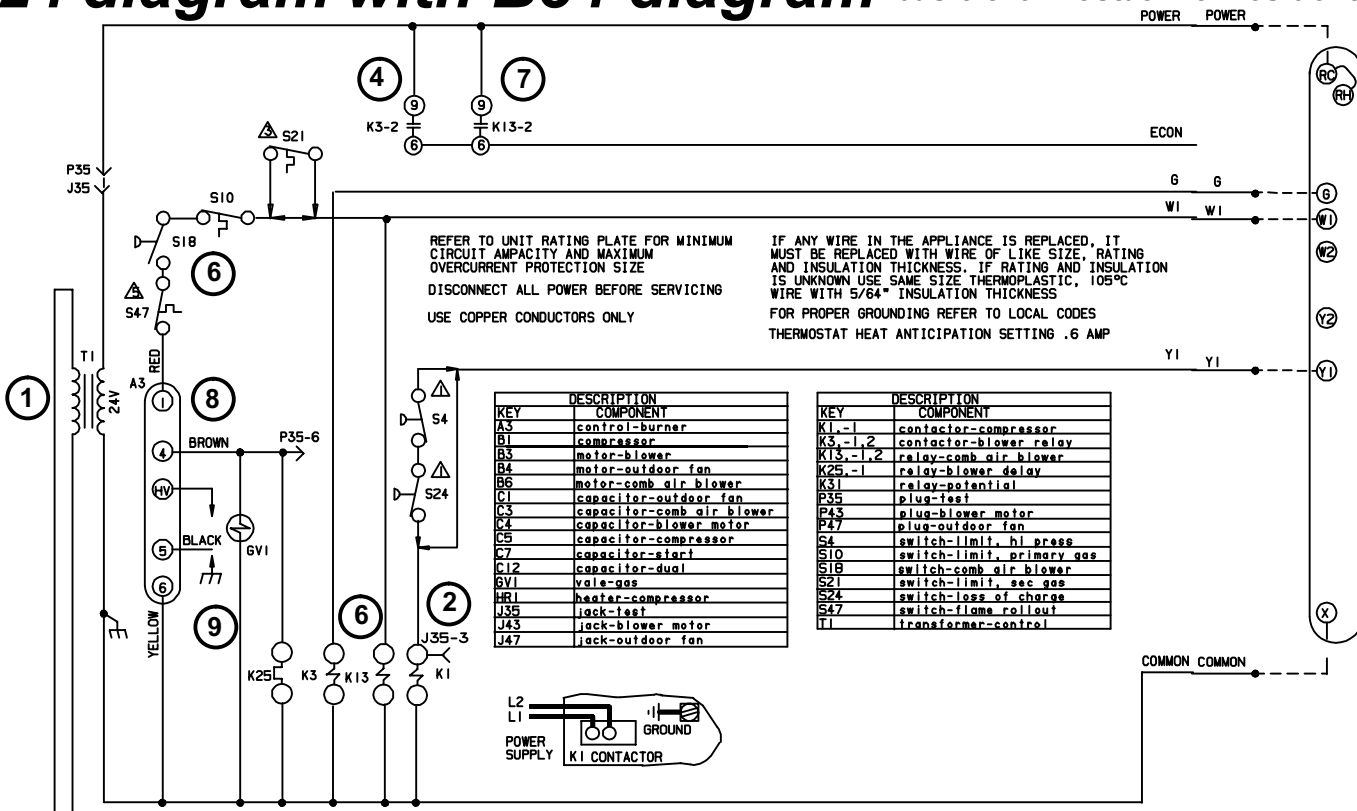

FAN SPEED

UNIT	FAN SPEED		
	COOL	HEAT	HEAT
-26	HI(2)	HI(2)	MED-HI(3)
-31	HI(2)	HI(2)	MED-HI(3)
-411-50	MED-HI(3)	MED-L(4)	L(5)
-411-100	MED-HI(3)	MED-HI(3)	MED-L(4)
-511	MED(4)	MED-L(5)	MED(4)
-651-75	MED-HI(3)	MED(4)	MED-L(5)
-651-125	MED-HI(3)	MED(4)	MED-L(5)

NOTE-ALL REMAINING WIRES FACTORY INSTALLED

--- LINE VOLTAGE FIELD INSTALLED
--- NEC/CEC-CLASS I

LENNOX Industries Inc. WIRING DIAGRAM 8/89

COMBINATION UNITS-ROOFTOP

GCS16H-261,311-50,75-1P
GCS16R,GCS16-411,511,651-1P

CONTROL SECTION-B34

Supersedes Form No. _____ New Form No. _____

Litho U.S.A.

--- LOW VOLTAGE FIELD WIRING
--- FACTORY WIRING

LENNOX Industries Inc. WIRING DIAGRAM 6/89

ACCESSORIES

THERMOSTAT FOR
CHA/GCS16 H & R UNITS

THERMOSTAT SECTION C24

Supersedes Form No. _____ New Form No. _____

Litho U.S.A.

C24 DIAGRAM AND B34 DIAGRAM
Electromechanical or Electronic Thermostat
Connected to Residential units (GCS16R and GCS16H)
without Economizer Harness or Unit Terminal Strip

A-RESIDENTIAL THERMOSTAT SYSTEMS

This flowchart is used to show the step by step sequence that takes place when thermostat demand is sent to the GCS16. The sequence describes the actions of devices in the unit which control blowers, fans, gas valves and other components in the system. The sequence is outlined by numbered steps which correspond to circled numbers on the adjacent diagram.

1- C24 SECTION and B34 SECTION (electromechanical or electronic thermostat wired to residential unit with pigtails)

The following is an explanation of Lennox' model number designations:

GCS16R: Residential unit without crankcase heater, high pressure switch, loss of charge switch and low voltage terminal strip.

GCS16H: Same as GCS16R except in horizontal only (non-convertible) cabinet.

GCS16: Commercial unit with crankcase heater, high pressure switch, loss of charge switch and low voltage terminal strip.

GCS16R and GCS16H units are designed for residential use only and are not equipped with the necessary hardware for connecting optional control systems or economizer. The C24 thermostat section is a straightforward residential thermostat design for the GCS16R and GCS16H exclusively. The thermostat used may be electromechanical or electronic.

511 and 651 units are factory equipped with hard start components (start capacitor and potential relay). 261, 311 and 411 units are not. All units except for 411s use separate compressor and fan run capacitors. 411 units use a single "dual" capacitor for both the compressor and condenser fan motors.

NOTE - This is a basic operation sequence for a single phase GCS16. The sequence shows a single phase GCS16R or GCS16H connected to a "C24" thermostat control section.

Operation Sequence

Cooling:

- 1- Line voltage energizes transformer T1. Transformer T1 provides 24VAC power to all unit controls and thermostat.

- 2- Cooling demand energizes Y1 and G in the thermostat. Y1 energizes compressor contactor K1. G energizes relay K3.
- 3- K1 is a single pole contactor, allowing compressor terminal R and one leg of the condenser fan to be powered at all times. K1-1 closes to energize compressor start circuit, compressor terminal C and condenser fan. Condenser fan immediately begins operating.
- 4- K3 contacts 7-4 close to energize the indoor blower on cooling speed. Contacts 6-9 close to energize the economizer.
- 5- As the compressor gains speed, compressor terminal S is powered by start capacitor C7. When the compressor nears full speed, potential relay K31 is energized and the start capacitor is taken out of the circuit. K31 remains energized during compressor operation. Run capacitor C5 remains in the circuit between terminals R and S to optimize motor efficiency.

Heating:

- 6- Heating demand initiates at W1 in the thermostat and energizes relay K13. Heating demand also passes through high temperature limit S10 to combustion air prove switch S18.
- 7- Relay K13 terminals 4-7 close to energize combustion air blower B6. Terminals 6-9 close to energize the economizer (commercial units only). When the combustion air blower nears full speed, prove switch S18 closes. Heating demand continues through S18 and through high temperature limit S47 to energize ignition control terminal 1.
- 8- Ignition control A3 then waits 30 to 40 seconds to allow combustion air blower B6 time to draw exhaust gas from combustion chamber and to introduce fresh air. Combustion air blower B6 operates throughout the heating cycle.
- 9- After the ignition control delay, A3 activates gas valve GV1, time delay K25 and the spark electrode. When flame is sensed by the flame sensor (minimum 5 microamps) the spark electrode stops. If flame is not sensed after the first trial for ignition, controller A3 repeats steps 8 through 9 up to two more times (depending on controller make) before locking out. Delay relay K25 delays 60 seconds before closing.

If the control locks out, it can be reset by breaking and remaking thermostat demand.

- 10- After the 60 second delay, relay K25 closes to energize the indoor blower on heating speed.

C19 diagram with B34 diagram and D8 diagram

special limited commercial application of residential GCS16H
with basic thermostat, downturn transition and three-position economiz-

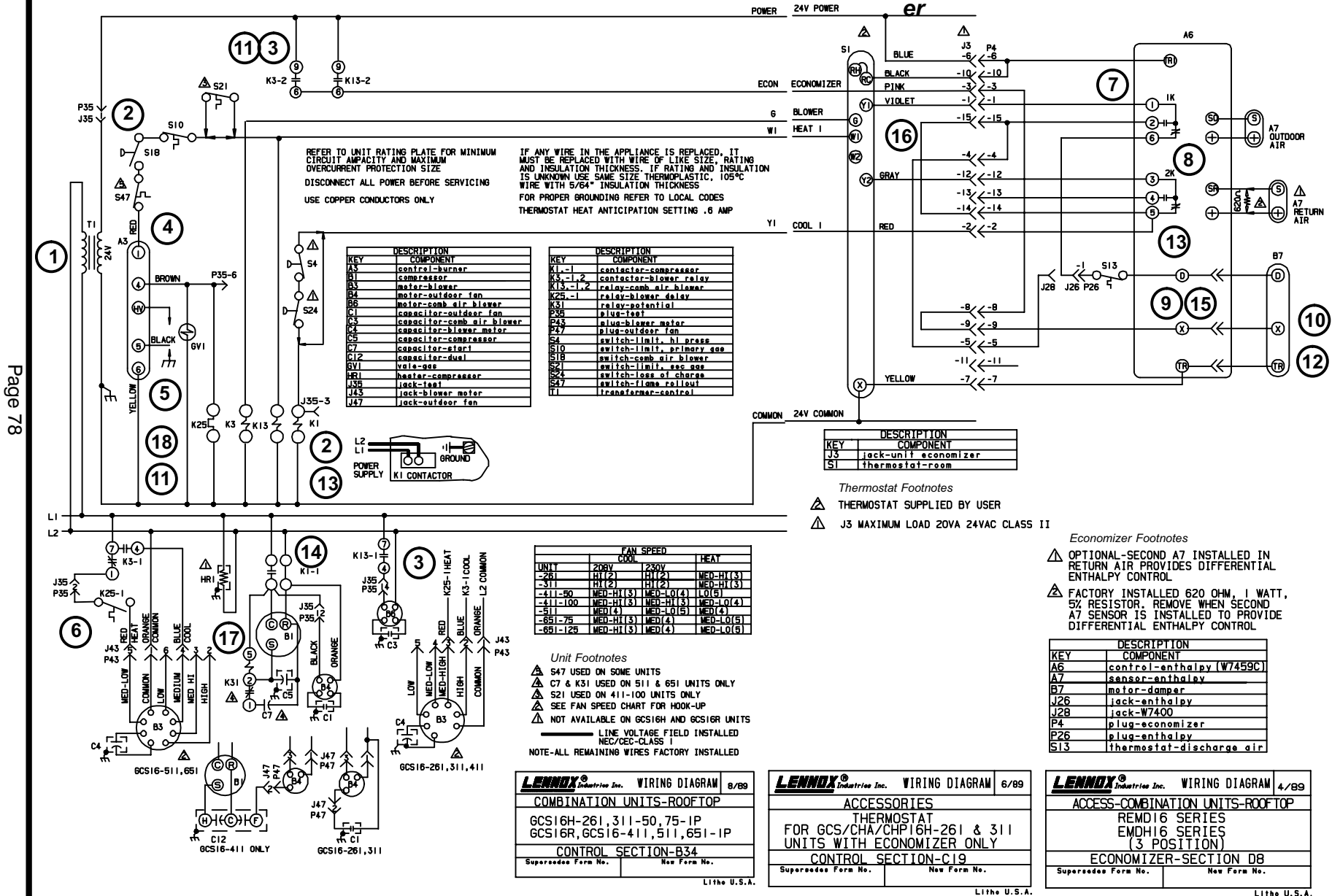

C19 DIAGRAM AND B34 DIAGRAM AND D8 DIAGRAM

Limited Commercial Application

Basic Electromechanical or Electronic Thermostat Connected to Residential Horizontal-Only Unit (GCS16H) with RDE16 and Three-Position Economizer

2- C19 SECTION and B34 SECTION with D8 Section (commercial application of electromechanical or electronic thermostat wired to residential unit with three-position economizer)

GCS16H units, even though not equipped for commercial use, may be converted to commercial downflow use in a special limited application. The application requires use of RDE16-41 roof duct enclosure to convert the unit to downflow use. The RDE16-41 includes a factory installed harness for connecting optional REMD16-41 or REMD16M-41 economizer.

NOTE - The RDE16-41 economizer harness is represented in diagram C19. The economizer harness and jack J3 are located inside the RDE16-41, not inside the unit as in other GCS16 commercial units. REMEMBER, this is a limited application converting a residential unit to commercial use.

The harness (shown in diagram C19) has pigtailed on the unit end and harness jack J3 on the economizer end. The unit end of the harness hard wires to the unit and thermostat with pigtailed. Economizer jack J3 at the end of the harness connects directly into economizer plug P4. Field wiring is shown in more detail in figure 59.

This particular application connects the REMD16-41 three-position economizer to the GCS16H. The RDE16-41 return air side panel is removed and the REMD16-41 slides into the side of the cabinet (same as it would into the side of a commercial GCS16). Economizer harness jack is located in the return air compartment of the RDE16-41. This installation is shown in figures 92 and 57.

Operation Sequence:

- 1- Line voltage energizes transformer T1. Transformer T1 provides 24VAC power to all unit controls and thermostat.
- 2- Heating demand initiates at W1 in the thermostat and energizes relay K13. Heating demand also passes through high temperature limits S10 to combustion air prove switch S18.
- 3- Relay K13 terminals 4-7 close to energize combustion air blower B6. Terminals 6-9 close to energize the economizer (commercial units only). When the combustion air blower nears full speed, prove switch S18 closes. Heating demand continues through S18 and through high temperature limit S47 to energize ignition control terminal 1.
- 4- Ignition control A3 then waits 30 to 40 seconds to allow combustion air blower B6 time to draw exhaust gas from combustion chamber and to introduce fresh air. Combustion air blower B6 operates throughout the heating cycle.
- 5- After the ignition control delay, A3 activates gas valve GV1, time delay K25 and the spark electrode. When flame is sensed by the flame sensor (minimum 5 microamps) the spark electrode stops. If flame is not sensed after the first trial for ignition, controller A3 repeats steps 4 through 5 up to two more times (depending on controller make) before locking out. Delay relay K25 delays 60 seconds before closing.
If the control locks out, it can be reset by breaking and remaking thermostat demand.
- 6- After the 60 second delay, relay K25 closes to energize the indoor blower on heating speed.

I. Enthalpy Control in Low Position (outside air can be used for cooling).

First stage cool (all models):

- 7- Initial cooling demand Y1 is sent to enthalpy control A6 terminal 1.

- 8- Enthalpy control A6 has determined that outside air can be used for cooling and has switched internal 1K and 2K internally.

- 9- Cooling demand is routed through enthalpy control terminal 6 and through discharge air thermostat S13 to enthalpy control terminal D and damper motor terminal D.

- 10- When 24VAC is applied across terminals D and T of damper motor, the damper motor energizes and outdoor dampers open fully. First stage cooling is provided by outdoor air.

- 11- Thermostat terminal G energizes relay K3. K3-1 closes to energize the indoor blower and K3-2 closes to energize the damper motor.

2nd stage cool (all models):

- 12- Economizer outdoor air dampers remain open.

- 13- Additional cooling demand is routed from thermostat Y2 through enthalpy control terminals 3 and 5 to energize contactor K1. The compressor provides all additional cooling.

- 14- K1 is a single pole contactor, allowing compressor terminal R and one leg of the condenser fan to be powered at all times. K1-1 closes to energize compressor terminal C, condenser fan motor and the run capacitors for each motor. Condenser fan and compressor immediately begin operating.

II. Enthalpy Control in High Position (outside air cannot be used for cooling).

Cooling:

- 15- Enthalpy control internal relays 1K and 2K switch. Voltage across D & TR drops out while voltage across X & TR continues. Outdoor air dampers close to minimum position.

- 16- Cooling demand is sent from thermostat terminal Y1 through enthalpy control terminals 1 and 2 and through enthalpy control terminal 5 to energize the compressor. The compressor handles all cooling demand.

- 17- K1 is a single pole contactor, allowing compressor terminal R and one leg of the condenser fan to be powered at all times. K1-1 closes to energize compressor terminal C, condenser fan motor and the run capacitors for each motor. Condenser fan and compressor immediately begin operating.

- 18- Thermostat terminal G energizes relay K3. K3-1 closes to energize the indoor blower and K3-2 closes to energize the damper motor.

Night Setback (optional field installed-steps not shown on diagram)

- 19- Optional field installed time clock (not shown), night thermostat S12 and night relay K11 must be connected for night setback operation.

- 20- Blower B3 operates only during a heating demand when night thermostat is closed.

- 21- When clock contacts close (not shown), relay K11 energizes. Contacts K11-1 open to disable the day thermostat and contacts K11-2 open to drive the dampers full closed.

- 22- (Not shown) Night thermostat S12 is typically set with setpoints below thermostat S1. During unoccupied periods, K11-1 opens while S1 is disabled. When S12 closes, power is supplied to S1 and the unit operates normally. When S12's setpoint is reached, S12 opens, S1 is disabled and unit operation stops.

- 23- Shortly before the building is to be occupied, clock contacts open to de-energize relay K11. Contacts K11-1 close to restore power the thermostat S1 and Contacts K11-2 close to restore power to the minimum positioner. Outdoor air dampers open to mid (minimum) position during blower operation.

C19 diagram with B34 diagram and D5 diagram

special limited commercial application of residential GCS16H
with basic thermostat, downturn transition and modulating economiz-

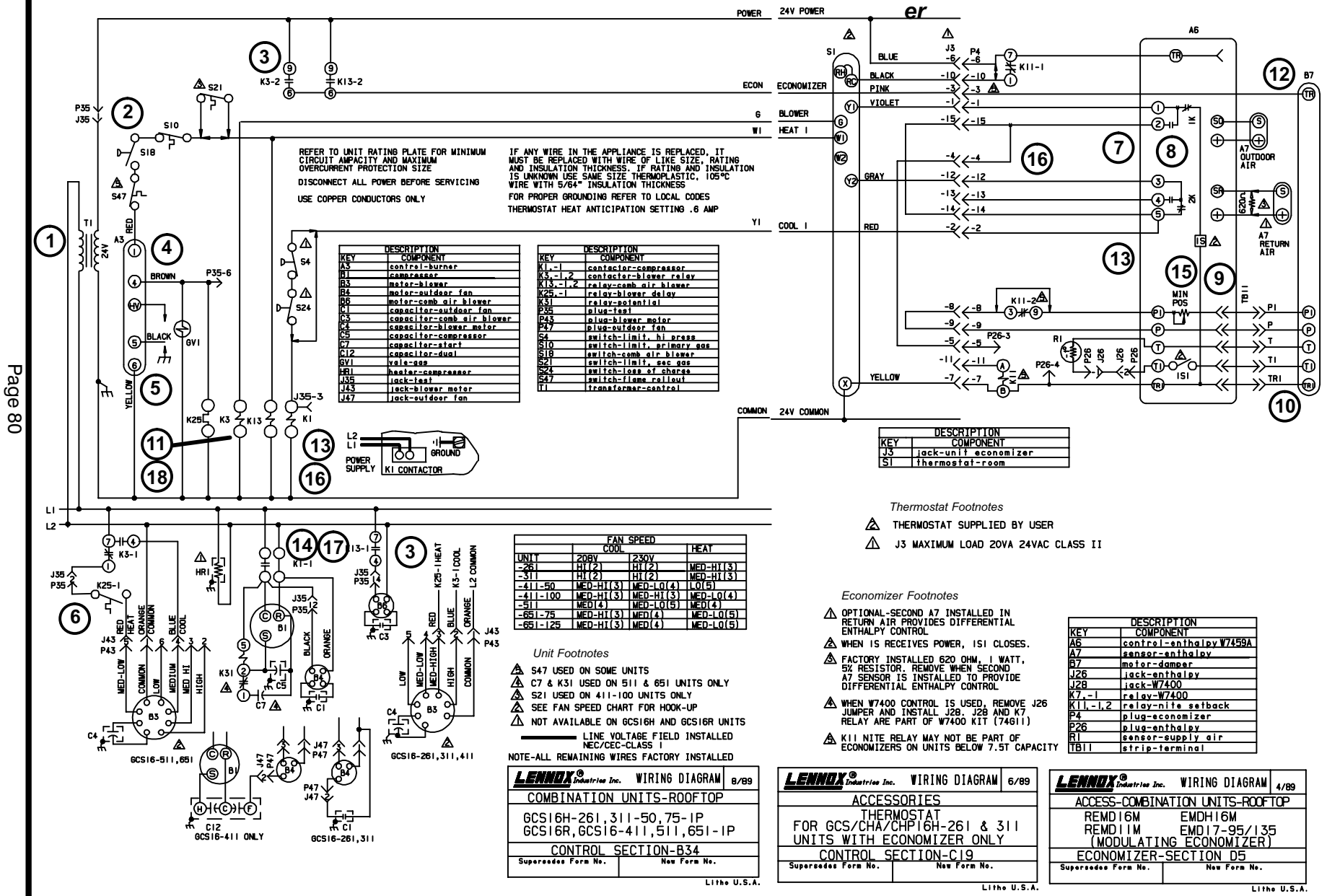

REFER TO UNIT RATING PLATE FOR MINIMUM CIRCUIT AMPACITY AND MAXIMUM OVERCURRENT PROTECTION SIZE
DISCONNECT ALL POWER BEFORE SERVICING
USE COPPER CONDUCTORS ONLY

IF ANY WIRE IN THE APPLIANCE IS REPLACED, IT MUST BE REPLACED WITH WIRE OF LIKE SIZE, RATING AND INSULATION THICKNESS. IF RATING AND INSULATION IS UNKNOWN USE SAME SIZE THERMOPLASTIC, 105°C WIRE WITH 5/8" INSULATION THICKNESS
FOR PROPER GROUNDING REFER TO LOCAL CODES
THERMOSTAT HEAT ANTICIPATION SETTING .6 AMP

KEY	COMPONENT
A5	control-burner
B1	capacitor
B3	motor-blower
B4	motor-outdoor fan
B6	motor-comb air blower
C3	capacitor-outdoor fan
C4	capacitor-comb air blower
C5	capacitor-blower motor
C7	capacitor-compressor
C7	capacitor-start
C12	capacitor-dual
GV1	valve-gas
H61	heater-compressor
J35	jack-leak
J45	jack-blower motor
J47	jack-outdoor fan

KEY	COMPONENT
K1-1	contactor-compressor
K3-1,2	contactor-blower relay
K13-1,2	relay-comb air blower
K25-1	relay-blower delay
K31	relay-potential
P26	plug-fan
P43	plug-blower motor
P47	plug-outdoor fan
S4	switch-limit, hi press
S10	switch-limit, primary gas
S18	switch-comb air blower
S21	switch-limit, sec gas
S24	switch-loss of charge
S47	switch-flame rollout
T1	transformer-control

KEY	COMPONENT
J3	jack-unit economizer
S1	thermostat-room

Thermostat Footnotes

- △ THERMOSTAT SUPPLIED BY USER
- △ J3 MAXIMUM LOAD 20VA 24VAC CLASS II

Economizer Footnotes

- △ OPTIONAL-SECOND A7 INSTALLED IN RETURN AIR PROVIDES DIFFERENTIAL ENTHALPY CONTROL
- △ WHEN IS RECEIVES POWER, IS1 CLOSSES.
- △ FACTORY INSTALLED 620 OHM, 1 WATT, 5% RESISTOR. REMOVE WHEN SECOND A7 SENSOR IS INSTALLED TO PROVIDE DIFFERENTIAL ENTHALPY CONTROL.
- △ WHEN W7400 CONTROL IS USED, REMOVE J26 JUMPER AND INSTALL J28. J28 AND K7 RELAY ARE PART OF W7400 KIT (74611)
- △ K11 NITE RELAY MAY NOT BE PART OF ECONOMIZER ON UNITS BELOW 7.5T CAPACITY

KEY	COMPONENT
A6	control-enthalpy W7459A
A7	sensor-enthalpy
B7	motor-damper
J26	jack-enthalpy
J28	jack-W7400
K7-1	relay-W7400
K11-1,2	relay-nite setback
P4	plug-economizer
P26	plug-enthalpy
R1	sensor-supply air
TB11	strip-terminal

UNIT	FAN SPEED		HEAT	
	208V	230V	MED-HI(3)	MED-LQ(5)
-26	HI(2)	HI(2)	MED-HI(3)	MED-LQ(5)
-31	HI(2)	HI(2)	MED-HI(3)	MED-LQ(5)
-41-50	MED-HI(3)	MED-LQ(4)	MED-LQ(4)	MED-LQ(5)
-41-100	MED-HI(3)	MED-HI(3)	MED-LQ(4)	MED-LQ(5)
-51	MED(4)	MED-LQ(5)	MED(4)	MED-LQ(5)
-651-75	MED-HI(3)	MED(4)	MED-LQ(5)	MED-LQ(5)
-651-125	MED-HI(3)	MED(4)	MED-LQ(5)	MED-LQ(5)

Unit Footnotes

- △ S47 USED ON SOME UNITS
- △ C7 & K31 USED ON 511 & 651 UNITS ONLY
- △ S21 USED ON 411-100 UNITS ONLY
- △ SEE FAN SPEED CHART FOR HOOK-UP
- △ NOT AVAILABLE ON GCS16H AND GCS16R UNITS
- △ LINE VOLTAGE FIELD INSTALLED NEC/CEC-CLASS I

NOTE-ALL REMAINING WIRES FACTORY INSTALLED

LENNOX[®] Industries Inc. WIRING DIAGRAM 8/89

COMBINATION UNITS-ROOFTOP

GCS16H-261, 311-50, 75-1P
GCS16R, GCS16-411, 511, 651-1P

CONTROL SECTION-B34

Supersedes Form No. _____ New Form No. _____

Litho U.S.A.

LENNOX[®] Industries Inc. WIRING DIAGRAM 6/89

ACCESSORIES

THERMOSTAT
FOR GCS/CHA/CHP16H-261 & 311
UNITS WITH ECONOMIZER ONLY

CONTROL SECTION-C19

Supersedes Form No. _____ New Form No. _____

Litho U.S.A.

LENNOX[®] Industries Inc. WIRING DIAGRAM 4/89

ACCESS-COMBINATION UNITS-ROOFTOP

REMD16M EMDH16M
REMD11M EMD17-95/135
(MODULATING ECONOMIZER)

ECONOMIZER-SECTION D5

Supersedes Form No. _____ New Form No. _____

Litho U.S.A.

C19 DIAGRAM WITH B34 DIAGRAM AND D5 DIAGRAM

Limited Commercial Application

Basic Electromechanical or Electronic Thermostat Connected to Residential Horizontal-Only Unit (GCS16H) with RDE16-41 and Modulating Economizer

3- C19 SECTION and B34 SECTION with D5 Section (commercial application of electromechanical or electronic thermostat wired to residential unit with modulating economizer)

GCS16H units, even though not equipped for commercial use, may be converted to commercial down-flow use in a special limited application. The application requires use of RDE16 roof duct enclosure to convert the unit to downflow use. The RDE16-41 includes a factory installed harness for connecting optional REMD16M-41 or REMD16-41 economizer.

NOTE - The RDE16 economizer harness is represented in diagram C19. The economizer harness and jack J3 are located inside the RDE16, not inside the unit as in other GCS16 commercial units. REMEMBER, this is a limited application converting a residential unit to commercial use.

The harness (shown in diagram C19) has pigtailed on the unit end and harness jack J3 on the economizer end. The unit end of the harness hard wires to the unit and thermostat with pigtailed. Economizer jack J3 at the economizer end of the harness connects directly into economizer plug P4. Field wiring is shown in more detail in figure 59.

This particular application connects the REMD16M modulating economizer to the GCS16H. The RDE16 return air side panel is removed and the REMD16M slides into the side of the cabinet (exactly as it would into the side of a commercial GCS16). Economizer harness jack is located in the return air compartment of the RDE16. This installation is shown in figures 92 and 57.

Operation Sequence:

- 1- Line voltage energizes transformer T1. Transformer T1 provides 24VAC power to all unit controls and thermostat.
- 2- Heating demand initiates at W1 in the thermostat and energizes relay K13. Heating demand also passes through high temperature limits S10 to combustion air prove switch S18.
- 3- Relay K13 terminals 4-7 close to energize combustion air blower B6. Terminals 6-9 close to energize the economizer (commercial units only). When the combustion air blower nears full speed, prove switch S18 closes. Heating demand continues through S18 and through high temperature limit S47 to energize ignition control terminal 1.
- 4- Ignition control A3 then waits 30 to 40 seconds to allow combustion air blower B6 time to draw exhaust gas from combustion chamber and to introduce fresh air. Combustion air blower B6 operates throughout the heating cycle.
- 5- After the ignition control delay, A3 activates gas valve GV1, time delay K25 and the spark electrode. When flame is sensed by the flame sensor (minimum 5 microamps) the spark electrode stops. If flame is not sensed after the first trial for ignition, controller A3 repeats steps 4 through 5 up to two more times (depending on controller make) before locking out. Delay relay K25 delays 60 seconds before closing.
If the control locks out, it can be reset by breaking and remaking thermostat demand.
- 6- After the 60 second delay, relay K25 closes to energize the indoor blower on heating speed.

Cooling:

I. Enthalpy Control in Low Position (outside air can be used for cooling).

First stage cool (all models):

- 7- Initial cooling demand Y1 is sent to enthalpy control A6 terminal 1.

- 8- Enthalpy control A6 has determined that outside air can be used for cooling and has switched relay 1K and 2K internally.
- 9- Cooling demand is routed through enthalpy control to energize internal relay 1S. Internal contacts 1S1 close to complete a circuit through damper motor terminals T and T1.
- 10- When a voltage is applied across terminals T and T1 of damper motor, the damper motor energizes and outdoor dampers open. Supply air sensor R1 varies the voltage across T and T1 and the outdoor air dampers adjust accordingly. First stage cooling is provided by outdoor air.
- 11- Thermostat terminal G energizes relay K3. K3-1 closes to energize the indoor blower and K3-2 closes to energize the damper motor.

2nd stage cool (all models):

- 12- Economizer outdoor air dampers remain open.
- 13- Additional cooling demand is routed from thermostat Y2 through enthalpy control terminals 3 and 5 to energize K1. The compressor provides all additional cooling.
- 14- K1 is a single pole contactor, allowing compressor terminal R and one leg of the condenser fan to be powered at all times. K1-1 closes to energize compressor terminal C, condenser fan motor and the run capacitors for each motor. Condenser fan and compressor immediately begin operating.

II. Enthalpy Control in High Position (outside air cannot be used for cooling).

- 15- Enthalpy control internal relays 1K and 2K switch. Internal relay 1S is de-energized and 1S1 opens. Outdoor air dampers close to minimum position.
- 16- Cooling demand is sent from thermostat terminal Y1 through enthalpy control terminals 1 and 2 and through enthalpy control terminal 5 to energize the compressor. The compressor handles all cooling.
- 17- K1 is a single pole contactor, allowing compressor terminal R and one leg of the condenser fan to be powered at all times. K1-1 closes to energize compressor terminal C, condenser fan motor and the run capacitors for each motor. Condenser fan and compressor immediately begin operating.
- 18- Thermostat terminal G energizes relay K3. K3-1 closes to energize the indoor blower and K3-2 closes to energize the damper motor.

Night Setback (optional field installed-not shown)

- 19- Optional field installed time-clock (not shown), night thermostat S12 (not shown) and Night Relay Kit K11 must be connected for night setback operation (night setback relay K11 not factory equipped in modulating economizer). See figure 59.
- 20- Blower B3 operates only during a heating demand when night thermostat is closed.
- 21- When clock contacts close (not shown), relay K11 energizes. Contacts K11-1 open to disable the day thermostat and contacts K11-2 open to drive the dampers full closed.
- 22- (Not Shown) Night thermostat S12 is typically set with setpoints below thermostat S1. During unoccupied periods, K11-1 opens while S1 is disabled. When S12 closes, power is supplied to S1 and the unit operates normally. When S12's setpoint is reached, S12 opens, S1 is disabled and unit operation stops.
- 23- Shortly before the building is to be occupied, clock contacts open to de-energize relay K11. Contacts K11-1 close to restore power the thermostat S1 and contacts K11-2 close to restore power to the minimum positioner. Outdoor air dampers open to minimum position during blower operation.

C1 diagram with B34 diagram basic thermostat with commercial single-phase GCS16

POWER 24V POWER

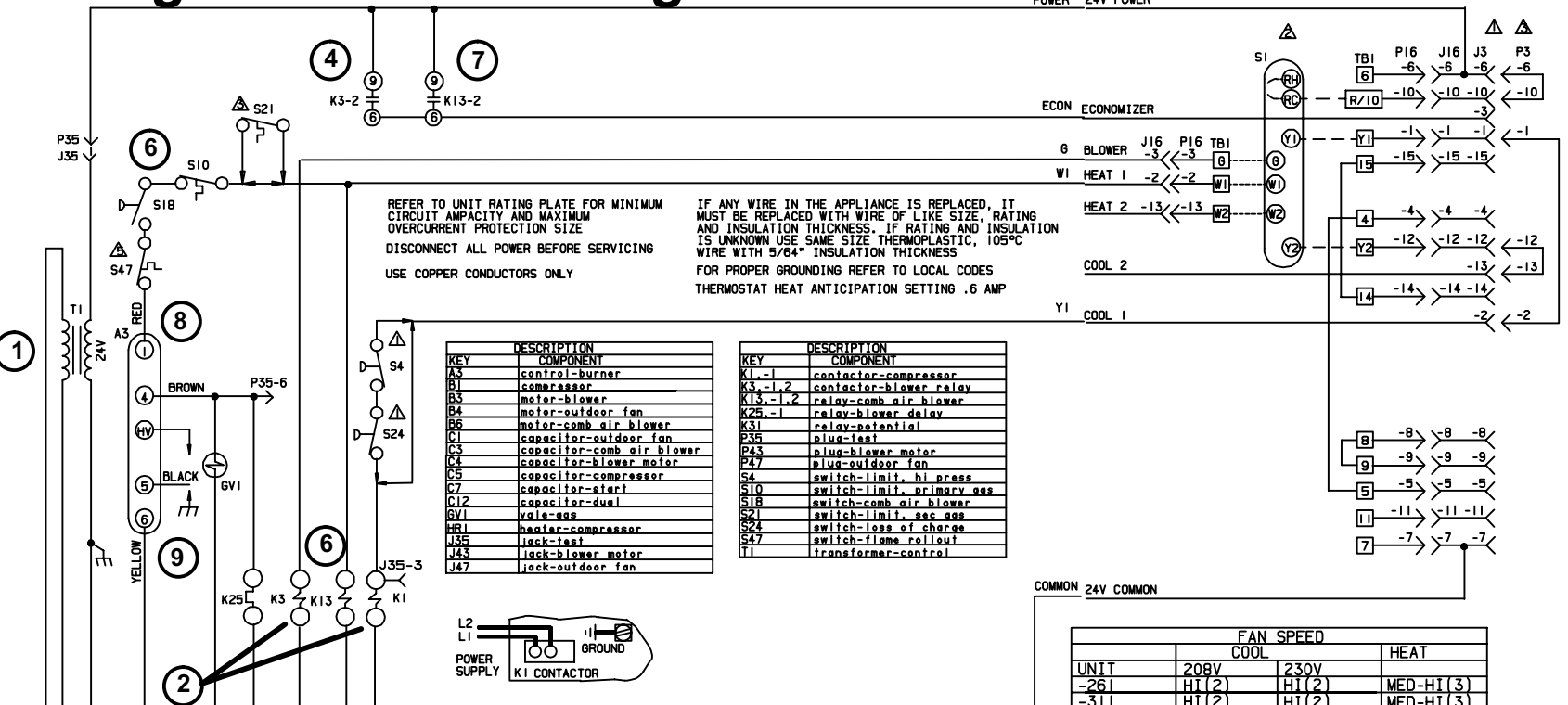

UNIT	FAN SPEED		
	COOL	230V	HEAT
-261	HI(2)	HI(2)	MED-HI(3)
-311	HI(2)	HI(2)	MED-HI(3)
-411-50	MED-HI(3)	MED-LO(4)	LO(5)
-411-100	MED-HI(3)	MED-HI(3)	MED-LO(4)
-511	MED(4)	MED-LO(5)	MED(4)
-651-75	MED-HI(3)	MED(4)	MED-LO(5)
-651-125	MED-HI(3)	MED(4)	MED-LO(5)

KEY	DESCRIPTION
J3	jack-unit economizer
J16	jack-unit
P3	plug-less economizer
P16	plug-unit
S1	thermostat-room
TB1	block-terminal

UNIT	FAN SPEED		
	COOL	230V	HEAT
-261	HI(2)	HI(2)	MED-HI(3)
-311	HI(2)	HI(2)	MED-HI(3)
-411-50	MED-HI(3)	MED-LO(4)	LO(5)
-411-100	MED-HI(3)	MED-HI(3)	MED-LO(4)
-511	MED(4)	MED-LO(5)	MED(4)
-651-75	MED-HI(3)	MED(4)	MED-LO(5)
-651-125	MED-HI(3)	MED(4)	MED-LO(5)

▲ S47 USED ON SOME UNITS
▲ C7 & K31 USED ON 511 & 651 UNITS ONLY
▲ S21 USED ON 411-100 UNITS ONLY
▲ SEE FAN SPEED CHART FOR HOOK-UP
▲ NOT AVAILABLE ON GCS16H AND GCS16R UNITS
— LINE VOLTAGE FIELD INSTALLED
— NEC/CEC-CLASS 1
NOTE-ALL REMAINING WIRES FACTORY INSTALLED

LENNOX Industries Inc. WIRING DIAGRAM 8/89

COMBINATION UNITS-ROOFTOP

GCS16H-261, 311-50, 75-1P
GCS16R, GCS16-411, 511, 651-1P

CONTROL SECTION-B34

Supersedes Form No. New Form No.

LENNOX Industries Inc. WIRING DIAGRAM 6/89

ACCESS-COMBINATION UNITS-ROOFTOP

ELECTROMECHANICAL THERMOSTAT
FOR 11 & 16 SERIES UNITS
(2 HEAT, 2 COOL)

THERMOSTAT-SECTION C1

Supersedes Form No. New Form No.

C1 DIAGRAM AND B34 DIAGRAM
Electromechanical Thermostat
Connected to single-phase commercial unit (GCS16)
without economizer

B-COMMERCIAL THERMOSTAT SYSTEMS

This flowchart is used to show the step by step sequence that takes place when thermostat demand is sent to the GCS16. The sequence describes the actions of devices in the unit which control blowers, fans, gas valves and other components in the system. The sequence is outlined by numbered steps which correspond to circled numbers on the adjacent diagram.

1- C1 SECTION and B34 SECTION (electromechanical thermostat wired to single-phase commercial unit)

The following is an explanation of Lennox' model number designations:

GCS16R: Residential unit without crankcase heater, high pressure switch, loss of charge switch and low voltage terminal strip.

GCS16H: Same as GCS16R except in horizontal only (non-convertible) cabinet.

GCS16: Commercial unit with crankcase heater, high pressure switch, loss of charge switch and low voltage terminal strip.

GCS16R and GCS16H units are designed for residential use only and are not equipped with the necessary hardware for connecting optional control systems or economizer. The C1 thermostat section is a straightforward electromechanical thermostat design for the commercial GCS16.

511 and 651 units are factory equipped with hard start components (start capacitor and potential relay). 261, 311 and 411 units are not. All units except for 411's use separate compressor and fan run capacitors. 411's use a single "dual" capacitor for both the compressor and condenser fan motors.

NOTE-This is a basic operation sequence for a single-phase GCS16. The sequence shows a single-phase commercial GCS16 connected to a "C1" thermostat control section.

Operation Sequence

Cooling:

1- Line voltage energizes transformer T1. Transformer T1 provides 24VAC power to all unit controls and thermostat.

2- Cooling demand energizes Y1 and G in the thermostat. Y1 energizes compressor contactor K1. G energizes relay K3.

3- K1 is a single pole contactor, allowing compressor terminal R and one leg of the condenser fan to be powered at all times. K1-1 closes to energize compressor start circuit, compressor terminal C and condenser fan. Condenser fan immediately begins operating.

4- K3 contacts 7-4 close to energize the indoor blower on cooling speed. Contacts 6-9 close to energize the economizer.

5- As the compressor gains speed, compressor terminal S is powered by start capacitor C7. When the compressor nears full speed, potential relay K31 is energized and the start capacitor is taken out of the circuit. K31 remains energized during compressor operation. Run capacitor C5 remains in the circuit between terminals R and S to optimize motor efficiency.

Heating:

6- Heating demand initiates at W1 in the thermostat and energizes relay K13. Heating demand also passes through high temperature limits S10 to combustion air prove switch S18.

7- Relay K13 terminals 4-7 close to energize combustion air blower B6. Terminals 6-9 close to energize the economizer (commercial units only). When the combustion air blower nears full speed, prove switch S18 closes. Heating demand continues through S18 and through high temperature limit S47 to energize ignition control terminal 1.

8- Ignition control A3 then waits 30 to 40 seconds to allow combustion air blower B6 time to draw exhaust gas from combustion chamber and to introduce fresh air. Combustion air blower B6 operates throughout the heating cycle.

9- After the ignition control delay, A3 activates gas valve GV1, time delay K25 and the spark electrode. When flame is sensed by the flame sensor (minimum 5 microamps) the spark electrode stops. If flame is not sensed after the first trial for ignition, controller A3 repeats steps 8 through 9 up to two more times (depending on controller make) before locking out. Delay relay K25 delays 60 seconds before closing. If the control locks out, it can be reset by breaking and remaking thermostat demand.

10- After the 60 second delay, relay K25 closes to energize the indoor blower on heating speed.

C1 diagram with B35 diagram

electromechanical thermostat without economizer connected to 208/230V-3ph. commercial unit

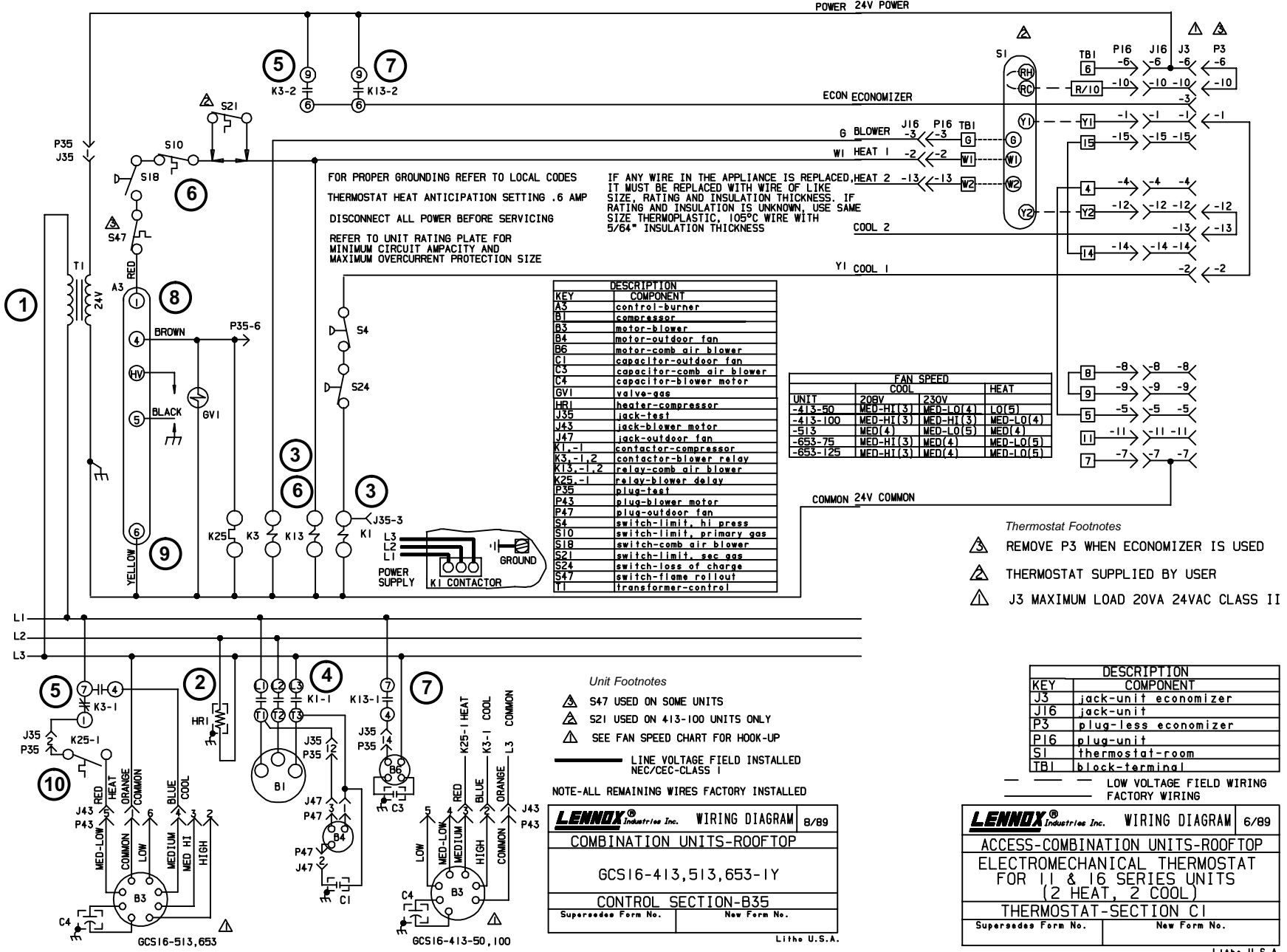

C1 diagram with B36 diagram

electromechanical thermostat without economizer connected to 460V or 575V - 3ph. commercial unit

POWER 24V POWER

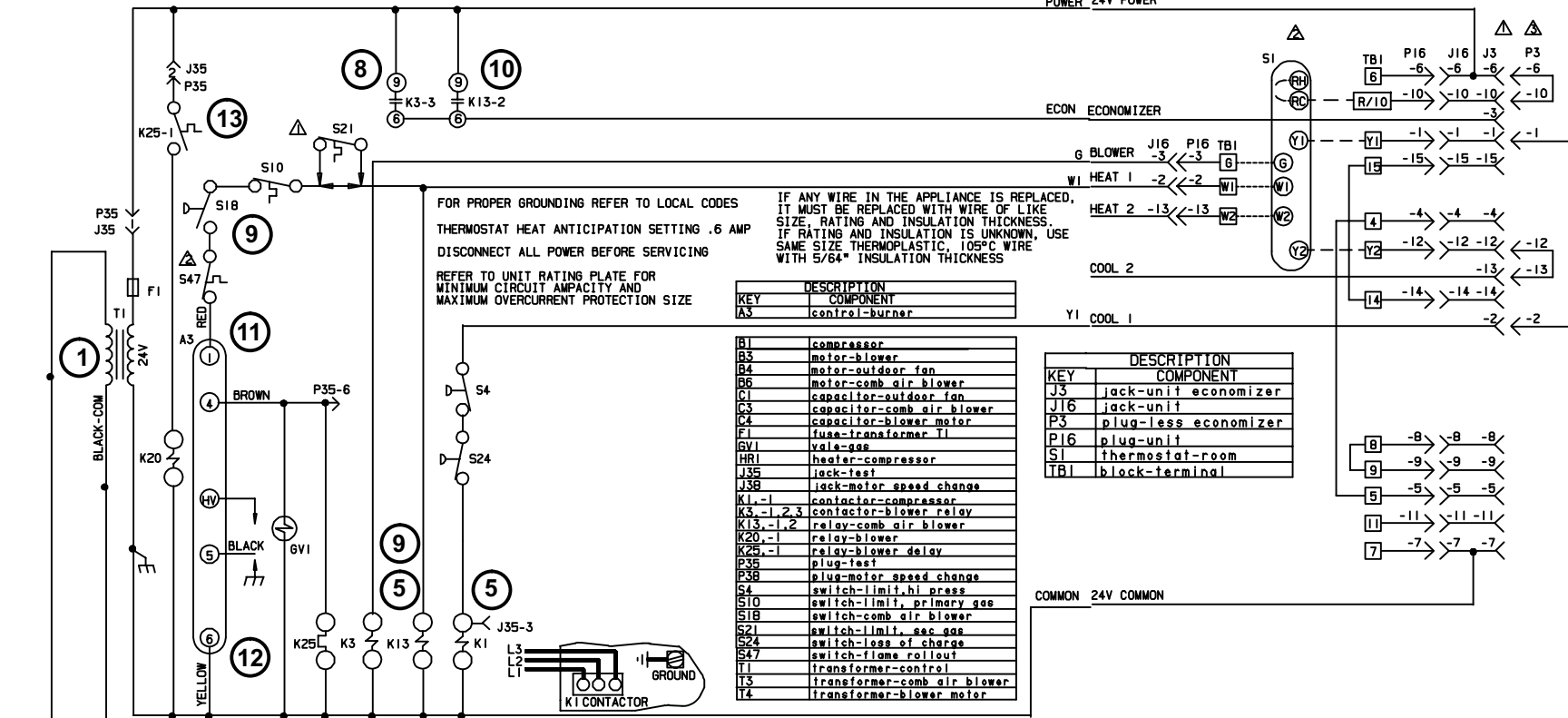

FOR PROPER GROUNDING REFER TO LOCAL CODES
THERMOSTAT HEAT ANTICIPATION SETTING .6 AMP
DISCONNECT ALL POWER BEFORE SERVICING
REFER TO UNIT RATING PLATE FOR MINIMUM CIRCUIT AMPACITY AND MAXIMUM OVERCURRENT PROTECTION SIZE

IF ANY WIRE IN THE APPLIANCE IS REPLACED, IT MUST BE REPLACED WITH WIRE OF LIKE SIZE, RATING AND INSULATION THICKNESS. IF RATING AND INSULATION IS UNKNOWN, USE SAME SIZE THERMOPLASTIC, 105°C WIRE WITH 5/64" INSULATION THICKNESS

KEY	DESCRIPTION
A3	control-burner
B1	compressor
B3	motor-blower
B4	motor-outdoor fan
B6	motor-comb air blower
C1	capacitor-outdoor fan
C3	capacitor-comb air blower
C4	capacitor-blower motor
F1	fuse-transformer TI
GV1	valve-gas
HRI	heater-compressor
J35	jack-test
J38	jack-motor speed change
K1-1	contactor-compressor
K3-1, 2, 3	contactor-blower relay
K13-1, 2	relay-comb air blower
K20-1	relay-blower
K25-1	relay-blower delay
P35	plug-test
P38	plug-motor speed change
S4	switch-limit, hi press
S10	switch-limit, primary gas
S18	switch-comb air blower
S21	switch-limit, sec gas
S24	switch-legs of charge
S47	switch-flame rollout
T1	transformer-control
T3	transformer-comb air blower
T4	transformer-blower motor

KEY	DESCRIPTION
J3	jack-unit economizer
J16	jack-unit
P3	plug-less economizer
P16	plug-unit
S1	thermostat-room
TBI	block-terminal

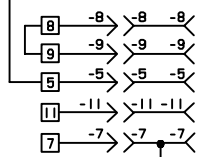

COMMON 24V COMMON

Page 85

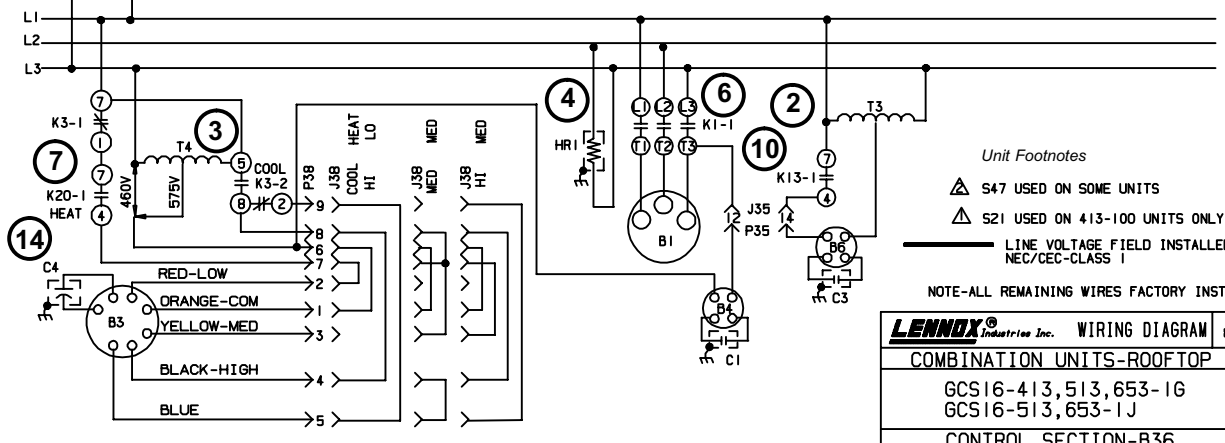

Unit Footnotes

- △ S47 USED ON SOME UNITS
- △ S21 USED ON 413-100 UNITS ONLY
- LINE VOLTAGE FIELD INSTALLED NEC/CEC-CLASS I

NOTE-ALL REMAINING WIRES FACTORY INSTALLED

Thermostat Footnotes

- △ REMOVE P3 WHEN ECONOMIZER IS USED
- △ THERMOSTAT SUPPLIED BY USER
- △ J3 MAXIMUM LOAD 20VA 24VAC CLASS II

— — — LOW VOLTAGE FIELD WIRING FACTORY WIRING

LENNOX [®] Industries Inc. WIRING DIAGRAM 8/89	
COMBINATION UNITS-ROOFTOP	
GCS16-413, 513, 653-1G	
GCS16-513, 653-1J	
CONTROL SECTION-B36	
Supersedes Form No.	New Form No.

Litho U.S.A.

LENNOX [®] Industries Inc. WIRING DIAGRAM 6/89	
ACCESS-COMBINATION UNITS-ROOFTOP	
ELECTROMECHANICAL THERMOSTAT	
FOR 11 & 16 SERIES UNITS	
(2 HEAT, 2 COOL)	
THERMOSTAT-SECTION C1	
Supersedes Form No.	New Form No.

Litho U.S.A.

C1 DIAGRAM CONNECTED TO B35 or B36 DIAGRAM

Electromechanical Thermostat with Three-Phase Commercial Units

2-C1 Section Connected to B35 Section

OPERATION SEQUENCE: 208/230V THREE-PHASE UNITS (TOP)

All units equipped with Crankcase Heater, High Pressure Switch, Loss of Charge Switch and low voltage terminal strip.

- 1- Line voltage energizes transformer T1. Transformer T1 provides 24VAC power to all unit controls, economizer (if used) and thermostat.
- 2- Compressor crankcase heater is self-regulating and is powered at all times.
- 3- Cooling demand energizes Y1 and G in the thermostat. Y1 passes through pressure switches S4 and S24 to energize compressor contactor K1. G energizes relay K3.
- 4- K1-1 closes to energize compressor and condenser fan. Both immediately begin operating.
- 5- K3 contacts 7-4 close to energize the indoor blower on cooling speed. Contacts 6-9 close to energize the economizer.
- 6- Heating demand energizes W1 in the thermostat. Heating demand energizes relay K13. Heating demand also passes through (secondary high temperature limit S21 - GCS16(R)-413-100 only) and high temperature limit S10 to combustion air prove switch S18.
- 7- Relay K13 terminals 4-7 close to energize combustion air blower B6. Terminals 6-9 close to energize the economizer. When the combustion air blower nears full speed, prove switch S18 closes. Heating demand passes through S18 and through flame rollout switch S47 to energize ignition control (A3) terminal 1.
- 8- Ignition control A3 then waits 30 to 40 seconds to allow combustion air blower B6 time to draw exhaust gas from combustion chamber and to introduce fresh air. Combustion air blower B6 operates throughout the heating cycle.
- 9- After ignition control delay, A3 activates gas valve GV1, time delay K25 and the spark electrode. When flame is sensed by the flame sensor (minimum 5 microamps) the spark electrode stops. If flame is not sensed after the first trial for ignition, controller A3 repeats steps 8 through 9 up to two more times (depending on controller make) before locking out. Delay relay K25 delays 60 seconds before closing.
If the control locks out, it can be reset by breaking and remaking thermostat demand.
- 10- After the 60 second delay, relay K25 closes to energize the indoor blower on heating speed.

3-C1 Section Connected to B36 Section

460V and 575V units are equipped with a unique blower motor. The blue motor lead is not a speed tap. It is used only to complete an internal circuit when the motor is operating at low or medium speed. Refer to unit components section of this manual for more information.

OPERATION SEQUENCE: 460/575V THREE-PHASE UNITS (ABOVE)

All units equipped with Crankcase Heater, High Pressure Switch, Loss of Charge Switch and Low Voltage Terminal Strip.

- 1- Line voltage energizes transformer T1. Transformer T1 provides 24VAC power to all unit controls, economizer (if used) and thermostat.
- 2- Transformer T3 is used in all 460V and 575V units. T3 provides 230VAC to combustion air blower B6. The transformer is powered at all times.
- 3- Transformer T4 is used in 575V units only. T4 provides 460VAC to indoor blower B3. Reduced voltage is provided to the common leg of the blower. It is powered at all times.
- 4- Compressor crankcase heater is self-regulating and is powered at all times.
- 5- Cooling demand energizes Y1 and G in the thermostat. Y1 energizes compressor contactor K1. G energizes relay K3.
- 6- K1-1 closes to energize compressor and condenser fan. Both immediately begin operating.
- 7- K3 contacts 7-1 open to disconnect heating speed. K3 contacts 8-2 open to disconnect the internal circuit (blue leg) and contacts 5-8 close to energize blower B3 on cooling speed.
- 8- K3 Contacts 6-9 close to energize the economizer.
- 9- Heating demand energizes W1 in the thermostat. Heating demand energizes relay K13. Heating demand also passes through (secondary high temperature limit S21 - GCS16(R)-413-100 only) and high temperature limit S10 to combustion air prove switch S18.
- 10- Relay K13 terminals 4-7 close to energize combustion air blower B6. Terminals 6-9 close to energize the economizer. When the combustion air blower nears full speed, prove switch S18 closes. Heating demand passes through S18 and through flame rollout switch S47 to energize ignition control terminal 1.
- 11- Ignition control A3 then waits 30 to 40 seconds to allow combustion air blower B6 time to draw exhaust gas from combustion chamber and to introduce fresh air. Combustion air blower B6 operates throughout the heating cycle.
- 12- After the ignition control delay, A3 activates gas valve GV1, time delay K25 and the spark electrode. When flame is sensed by the flame sensor (minimum 5 microamps) the spark electrode stops. If flame is not sensed after the first trial for ignition, controller A3 repeats steps 11 through 12 up to two more times (depending on controller make) before locking out. Delay relay K25 delays 60 seconds before closing.
If the control locks out, it can be reset by breaking and remaking thermostat demand.
- 13- After the 60 second delay, relay K25 closes to energize relay K20.
- 14- K20 terminals 4-7 close to energize the indoor blower on heating speed. K3 terminals 8-2 remain closed to complete an internal circuit.

C1 diagram with D8 diagram

24V POWER

electromechanical thermostat with three-position economizer

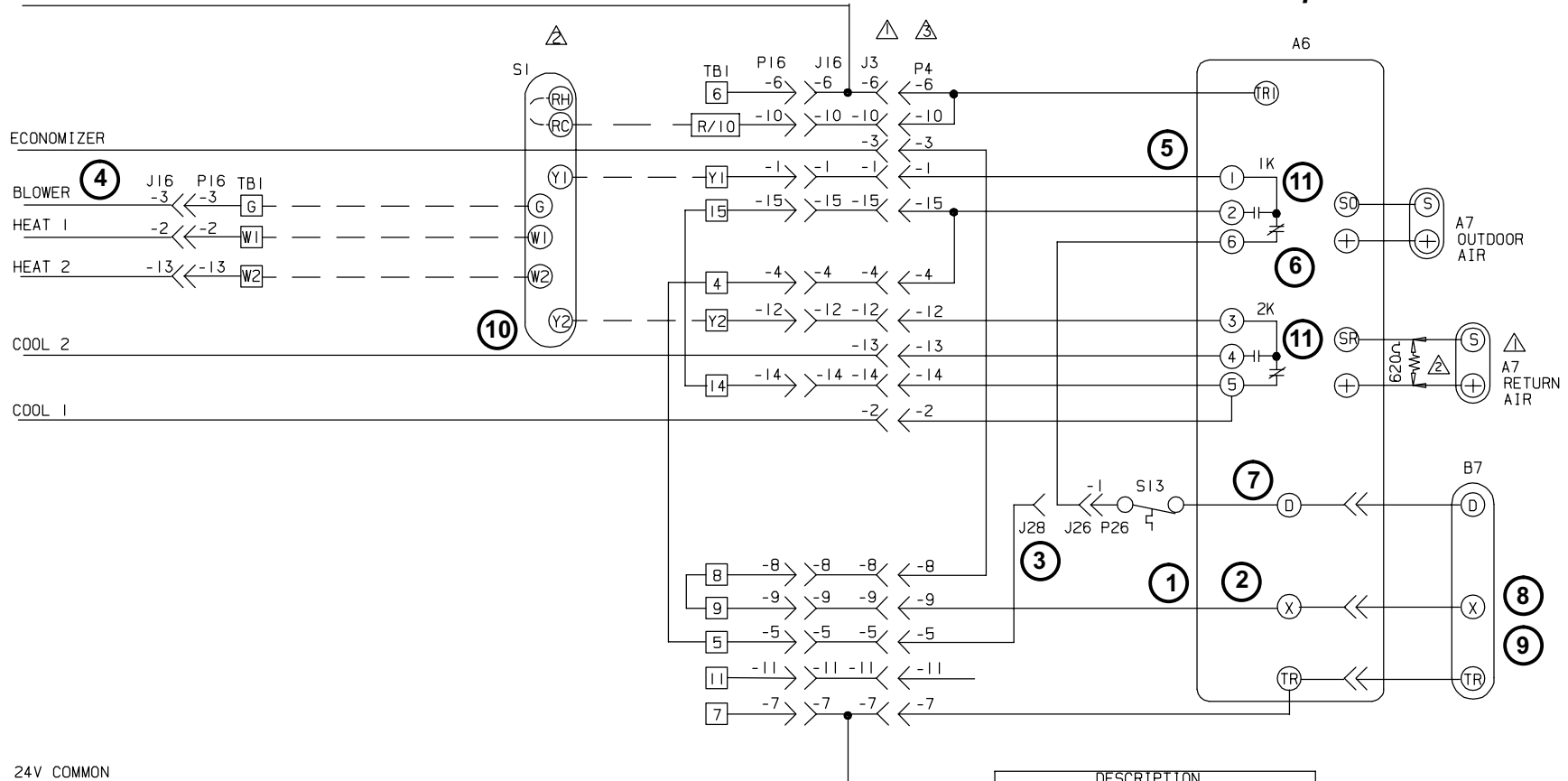

24V COMMON

--- LOW VOLTAGE FIELD WIRING
 _____ FACTORY WIRING

KEY	DESCRIPTION
J56	jack-unit economizer
J56	jack-unit
P46	plug-less economizer
P46	plug-unit
S1	thermostat-room
TB1	block-terminal

Thermostat Footnotes
 REMOVE P3 WHEN ECONOMIZER IS USED

Economizer Footnotes
 J3 MAXIMUM LOAD 20VA 24VAC CLASS II

OPTIONAL-SECOND A7 INSTALLED IN RETURN AIR PROVIDES DIFFERENTIAL ENTHALPY CONTROL

FACTORY INSTALLED 620 OHM, 1 WATT, 5% RESISTOR. REMOVE WHEN SECOND A7 SENSOR IS INSTALLED TO PROVIDE DIFFERENTIAL ENTHALPY CONTROL

KEY	DESCRIPTION
A6	control-enthalpy (W7459C)
A7	sensor-enthalpy
B7	motor-damper
J26	jack-enthalpy
J28	jack-W7400
P4	plug-economizer
P26	plug-enthalpy
S13	thermostat-discharge air

LENNOX Industries Inc. WIRING DIAGRAM 6/89	
ACCESS-COMBINATION UNITS-ROOFTOP	
ELECTROMECHANICAL THERMOSTAT FOR 11 & 16 SERIES UNITS (2 HEAT, 2 COOL)	
THERMOSTAT-SECTION C1	
Supersedes Form No.	New Form No.

Litho U.S.A.

LENNOX Industries Inc. WIRING DIAGRAM 4/89	
ACCESS-COMBINATION UNITS-ROOFTOP	
REMD16 SERIES EMD116 SERIES (3 POSITION)	
ECONOMIZER-SECTION D8	
Supersedes Form No.	New Form No.

Litho U.S.A.

C1 DIAGRAM WITH D8 DIAGRAM

Electromechanical Thermostat with Three-position Economizer

4-C1 Section with D8 Section - Basic (three-position) Economizer Operation

When a REMD16 or EMDH16 Economizer section is applied to the GCS16 with electromechanical thermostat, two stages of cooling are available dependent on the actions of the enthalpy control inside the economizer. By sensing outside temperature and relative humidity, the enthalpy control determines if outside air can be used as a first stage of cooling. If so, first stage cooling is handled by outdoor air dampers and 2nd stage cooling is handled by the compressor. When outdoor air conditions become unsatisfactory for cooling, the outdoor air dampers close and the compressor handles all cooling demand.

NOTE - In order to understand how optional controls affect operation of the GCS16, you must first read and understand how all the GCS16 components work.

Factory jumper-plug P3 is removed from unit harness jack J3 and discarded. Economizer plug P4 replaces plug P3. These connections are made in the unit blower compartment.

Operation Sequence:

NOTE- In this operation sequence the unit diagram has been omitted in order to concentrate on the interaction between thermostat and controls.

- 1- Economizer outdoor air dampers drive full closed any time blower B3 is not operating.
- 2- Enthalpy control A6 terminal X and damper motor terminal X are powered by unit relay K3 when there is a blower demand or by K13 when there is a heating demand. When 24VAC is applied between terminals TR and X, the damper motor is energized and the outdoor dampers open to mid (minimum) position.
- 3- Economizer jack J28 is not used in this application and should remain disconnected.
- 4- Blower B3 is energized by thermostat terminal G. On a cooling demand, thermostat terminal G energizes relay K3 (not shown) which in turn energizes the blower. When K3 energizes, K3-1 closes to energize the blower and K3-2 closes to energize the economizer and open the outdoor air dampers to mid (minimum) position.

I. Enthalpy Control in Low Position (outside air can be used for cooling).

1st stage cool (all models):

- 5- Initial cooling demand Y1 is sent to enthalpy control A6 terminal 1.

- 6- Enthalpy control A6 has determined that outside air can be used for cooling and has switched internal 1K and 2K internally.

- 7- Cooling demand is routed through enthalpy control terminal 6 and through discharge air thermostat S13 to enthalpy control terminal D and damper motor terminal D.

- 8- When 24VAC is applied across terminals D and T of damper motor, the damper motor energizes and outdoor dampers open fully. First stage cooling is provided by outdoor air.

2nd stage cool (all models):

- 9- Economizer outdoor air dampers remain open.

- 10- Additional cooling demand is routed from thermostat Y2 through enthalpy control terminals 3 and 5 to energize the compressor. The compressor provides all additional cooling demand.

II. Enthalpy Control in High Position (outside air cannot be used for cooling).

Cooling:

- 11- Cooling demand is sent from thermostat terminal Y1 through enthalpy control terminals 1 and 2 and through enthalpy control terminal 5 to energize the compressor. The compressor handles all cooling.

Night Setback (optional field installed - not shown)

- 12- Optional field installed time clock, night thermostat S12 (not shown) and night relay K11 (figure 59) must be connected for night setback operation.

- 13- Blower B3 operates only during a heating demand when night thermostat is closed.

- 14- When clock contacts close, relay K11 energizes. Contacts K11-1 open to disable the day thermostat and contacts K11-2 open to drive the dampers full closed.

- 15- Night thermostat S12 is typically set with setpoints below thermostat S1. During unoccupied periods, K11-1 opens while S1 is disabled. When S12 closes, power is supplied to S1 and the unit operates normally. When S12's setpoint is reached, S12 opens, S1 is disabled and unit operation stops.

- 16- Shortly before the building is to be occupied, clock contacts open to de-energize relay K11. Contacts K11-1 close to restore power the thermostat S1 and Contacts K11-2 close to restore power to the minimum positioner. Outdoor air dampers open to mid (minimum) position during blower operation.

C1 diagram with D5 diagram

electromechanical thermostat with modulating economizer

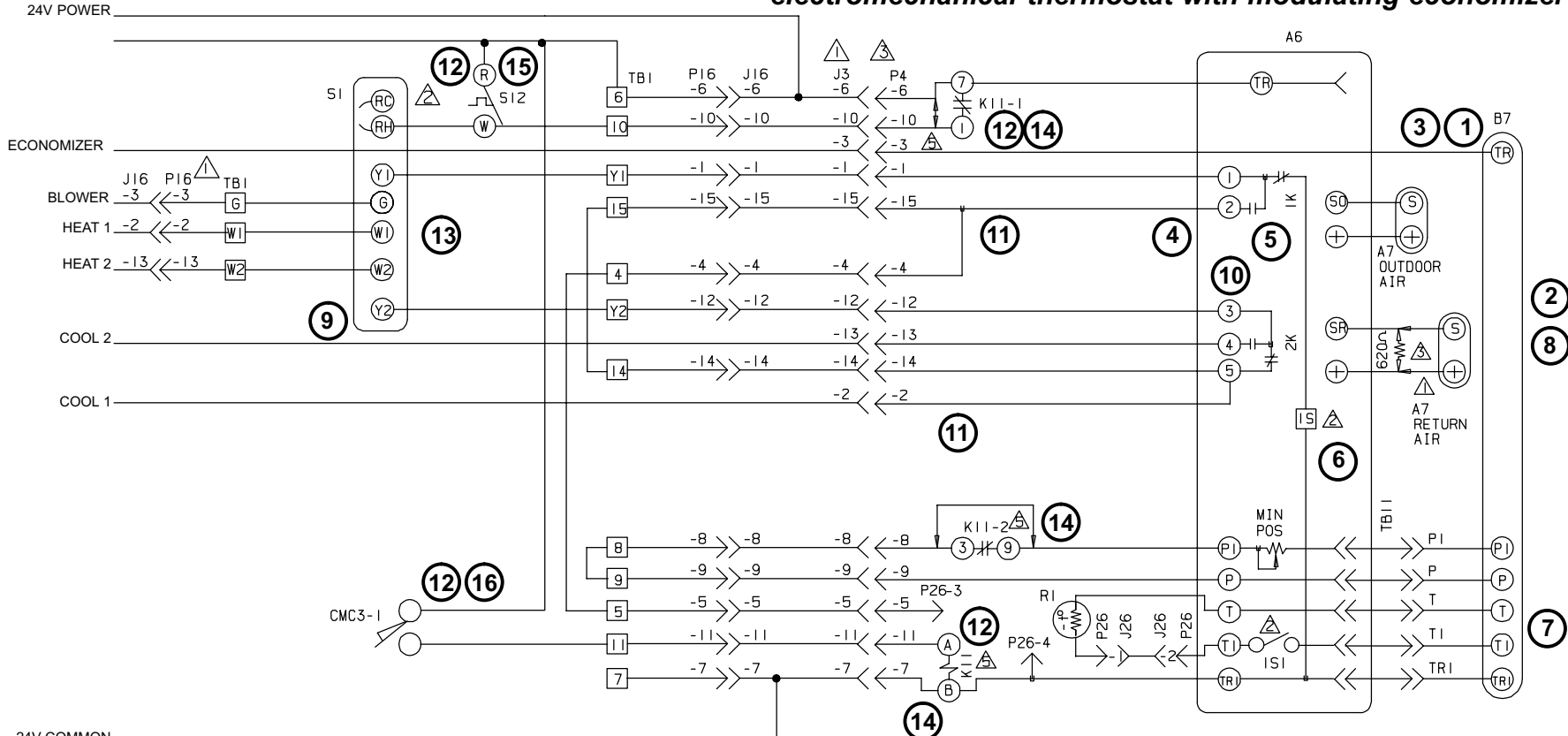

KEY	DESCRIPTION
J3	jack-unit economizer
J16	jack-unit
P3	plug-less economizer
P16	plug-unit
S1	thermostat-room
TB1	block-terminal

KEY	DESCRIPTION
A6	control-enthalpy W7459A
A7	sensor-enthalpy
B7	motor-damper
J26	jack-enthalpy
J28	jack-W7400
K7-1	relay-W7400
K11-1,2	relay-nite setback
P4	plug-economizer
P26	plug-enthalpy
R1	sensor-supply air
TB1	strip-terminal

- Economizer Footnotes**
- △ OPTIONAL-SECOND A7 INSTALLED IN RETURN AIR PROVIDES DIFFERENTIAL ENTHALPY CONTROL
 - △ WHEN IS RECEIVES POWER, IS1 CLOSES.
 - △ FACTORY INSTALLED 620 OHM, 1 WATT, 5% RESISTOR. REMOVE WHEN SECOND A7 SENSOR IS INSTALLED TO PROVIDE DIFFERENTIAL ENTHALPY CONTROL
 - △ WHEN W7400 CONTROL IS USED, REMOVE J26 JUMPER AND INSTALL J28. J28 AND K7 RELAY ARE PART OF W7400 KIT (74G11)
 - △ K11 NITE RELAY MAY NOT BE PART OF ECONOMIZERS ON UNITS BELOW 7.5T CAPACITY

- Thermostat Footnotes**
- △ REMOVE P3 WHEN ECONOMIZER IS USED
 - △ THERMOSTAT SUPPLIED BY USER
 - △ J3 MAXIMUM LOAD 20VA 24VAC CLASS II

LENNOX Industries Inc. WIRING DIAGRAM 6/89

ACCESS-COMBINATION UNITS-ROOFTOP
ELECTROMECHANICAL THERMOSTAT
FOR 11 & 16 SERIES UNITS
(2 HEAT, 2 COOL)

THERMOSTAT-SECTION C1

Supersedes Form No. _____ New Form No. _____

LENNOX Industries Inc. WIRING DIAGRAM 4/89

ACCESS-COMBINATION UNITS-ROOFTOP
REMD16M EMDH16M
REMD11M EMD17-95/135
(MODULATING ECONOMIZER)

ECONOMIZER-SECTION D5

Supersedes Form No. _____ New Form No. _____

C1 DIAGRAM with D5 DIAGRAM

Electromechanical Thermostat with Modulating Economizer

5-C1 Section with D5 Section - Basic (modulating) Economizer Operation

When a REMD16M or EMDH16M Economizer section is applied to the GCS16 with electro-mechanical thermostat, two stages of cooling are available dependent on the actions of the enthalpy control inside the economizer. By sensing outside temperature and relative humidity, the enthalpy control determines if outside air can be used as a first stage of cooling. If so, 1st stage cooling is handled by outdoor air dampers and 2nd stage cooling is handled by the compressor. The enthalpy control continuously adjusts the outdoor air dampers to maintain a balanced mixed air temperature. When outdoor air conditions become unsatisfactory for cooling, the outdoor air dampers close and the compressor handles all cooling demand.

NOTE - In order to understand how optional controls affect operation of the GCS16, you must first read and understand how all the GCS16 components work.

Factory jumper-plug P3 is removed from unit harness jack J3 and discarded. Economizer plug P4 replaces plug P3. These connections are made in the unit blower compartment.

Operation Sequence:

NOTE - In this operation sequence the unit diagram has been omitted in order to concentrate on the interaction between thermostat and controls.

- 1- Economizer outdoor air dampers drive full closed anytime blower B3 is not operating.
- 2- Damper motor terminal TR is powered by unit relay K3 when there is a blower demand or by K13 when there is a heating demand. When 24VAC is applied between terminals TR and TR1, the damper motor is energized and the outdoor dampers open to minimum position.
- 3- Blower B3 is energized by thermostat terminal G. On a cooling demand, thermostat terminal G energizes relay K3 which in turn energizes the blower. When K3 energizes, K3-1 closes to energize the blower and K3-2 closes to energize the economizer (see step 2) and open the outdoor air dampers to minimum position.

I. Enthalpy Control in Low Position (outside air can be used for cooling).

1st stage cool (all models):

- 4- Initial cooling demand Y1 is sent to enthalpy control A6 terminal 1.
- 5- Enthalpy control A6 has determined that outside air can be used for cooling and has switched internal 1K and 2K internally.

6- Cooling demand is routed through enthalpy control to energize internal relay 1S. Internal contacts 1S1 close to complete a circuit through damper motor terminals T and T1.

7- When a voltage is applied across terminals T and T1 of damper motor, the damper motor energizes and outdoor dampers open. Supply air sensor R1 varies the voltage across T and T1 and the outdoor air dampers adjust accordingly. 1st stage cooling is provided by outdoor air.

2nd stage cool (all models):

8- Economizer outdoor air dampers remain open.

9- Additional cooling demand is routed from thermostat Y2 through enthalpy control terminals 3 and 5 to energize the compressor. The compressor provides all additional cooling.

II. Enthalpy Control in High Position (outside air cannot be used for cooling).

Cooling:

10- Enthalpy control internal relays 1K and 2K switch. Internal relay 1S is de-energized and 1S1 opens. Outdoor air dampers close to minimum position.

11- Cooling demand is sent from thermostat terminal Y1 through enthalpy control terminals 1 and 2 and through enthalpy control terminal 5 to energize the compressor. The compressor handles all cooling.

Night Setback (optional field installed)

12- Optional field installed time-clock, night thermostat S12 and Night Relay K11 must be connected for night setback operation (night setback relay K11 not factory equipped in modulating economizer - it must be field installed for night setback).

13- Blower B3 operates only during a heating demand when night thermostat is closed.

14- When clock contacts close, relay K11 energizes. Contacts K11-1 open to disable the day thermostat and contacts K11-2 open to drive the dampers full closed.

15- Night thermostat S12 is typically set with setpoints below thermostat S1. During unoccupied periods, K11-1 opens while S1 is disabled. When S12 closes, power is supplied to S1 and the unit operates normally. When S12's setpoint is reached, S12 opens, S1 is disabled and unit operation stops.

16- Shortly before the building is to be occupied, clock contacts open to de-energize relay K11. Contacts K11-1 close to restore power the thermostat S1 and Contacts K11-2 close to restore power to the minimum positioner. Outdoor air dampers open to minimum position during blower operation.

C2-1 diagram with D8 diagram

electromechanical thermostat with three-position economizer and warm-up

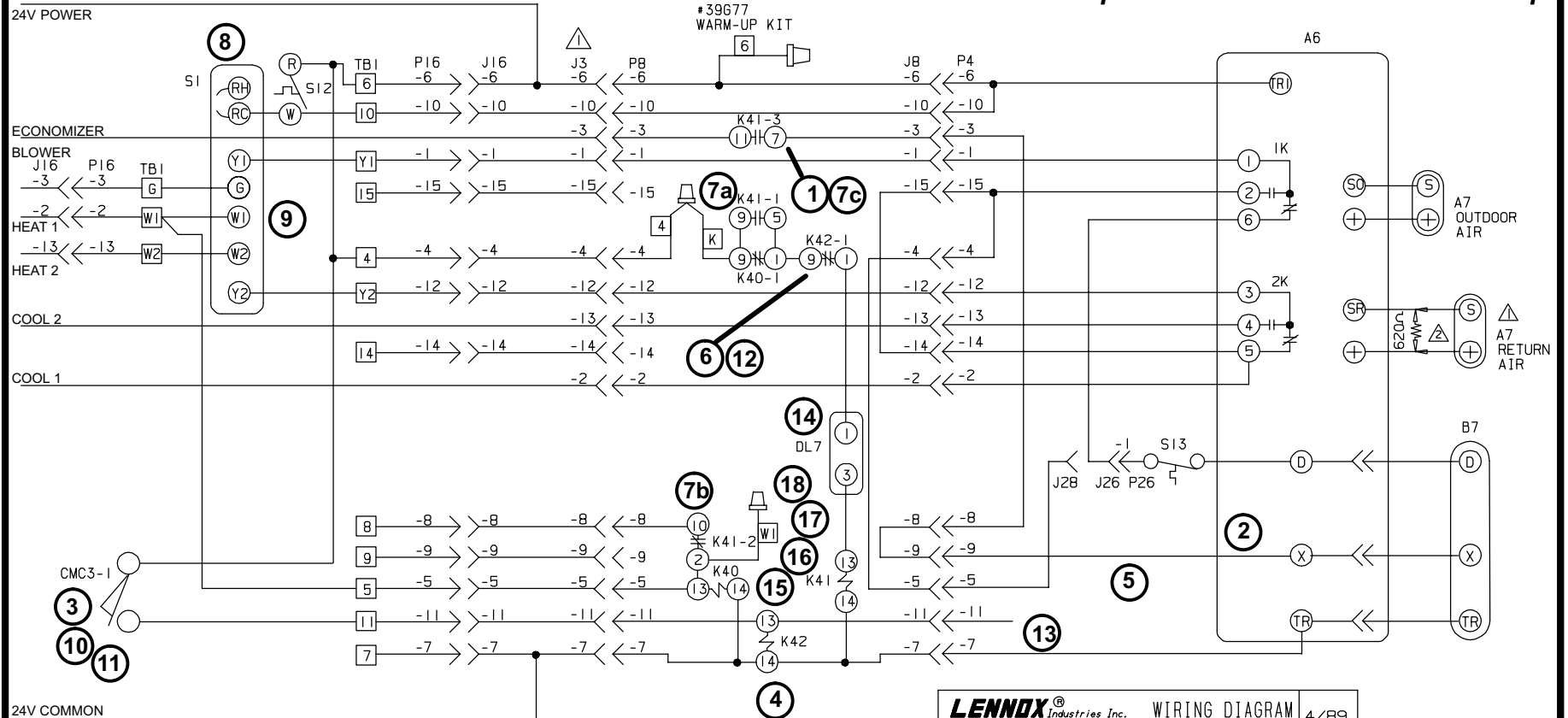

Page 91

KEY	DESCRIPTION
CMC3-1	timer-clock
DL7	delay-readout
J3	jack-economizer
J8	jack-warm up kit
J16	jack-unit
K40,-1	relay-warm up kit latch
K41,-1,2,3,4	relay-warm up kit latch
K42,-1	relay-warm up kit clock
P8	plug-warm up kit
P16	plug-unit
S1	thermostat-room
S12	thermostat-nite
TB1	block-terminal (low volt)

Unit Footnotes
 ⚠ J3 MAXIMUM LOAD 20VA 24VAC CLASS II

LENNOX® Industries Inc. WIRING DIAGRAM		8/87
ACCESS-COMBINATION UNITS-ROOFTOP		
THERMOSTAT SECTION FOR GCS, CHA, CHP11 & 16		
SERIES UNITS WITH WARM UP KIT		
THERMOSTAT SECTION-C2-1		
Supersedes Form No.	New Form No.	

Economizer Footnotes
 ⚠ OPTIONAL-SECOND A7 INSTALLED IN RETURN AIR PROVIDES DIFFERENTIAL ENTHALPY CONTROL
 ⚠ FACTORY INSTALLED 620 OHM, 1 WATT, 5% RESISTOR. REMOVE WHEN SECOND A7 SENSOR IS INSTALLED TO PROVIDE DIFFERENTIAL ENTHALPY CONTROL

LENNOX® Industries Inc. WIRING DIAGRAM		4/89
ACCESS-COMBINATION UNITS-ROOFTOP		
REMD16 SERIES		
EMDH16 SERIES		
(3 POSITION)		
ECONOMIZER-SECTION D8		
Supersedes Form No.	New Form No.	

KEY	DESCRIPTION
A6	control-enthalpy (W7459C)
A7	sensor-enthalpy
B7	motor-damper
J26	jack-enthalpy
J28	jack-W7400
P4	plug-economizer
P26	plug-enthalpy
S13	thermostat-discharge air

Litho U.S.A.

Litho U.S.A.

C2-1 DIAGRAM WITH D8 DIAGRAM

Electromechanical Thermostat with Three-position Economizer and Warm-Up

6-C2-1 Section with D8 Section

An optional feature of the REMD16 and EMDH16 Economizer is a warm-up kit which holds economizer outdoor air dampers closed during night heat operation and while the GCS16 is warming the building after night setback. The warm-up kit temporarily disables the economizer (dampers are held closed) during morning warm-up to keep cool outside air from being mixed with return air. Once the temperature setpoint is reached, the economizer is allowed to operate normally (outdoor air dampers open to mid position to allow for required minimum air exchange).

NOTE - In order to understand how optional controls affect operation of the GCS16, you must first read and understand how all the GCS16 components work.

NOTE -

- 1-The warm-up kit requires the use of optional time clock CMC3-1.
- 2-Optional field installed night relay (not shown - see C11 diagram) and night thermostat S12 are also required. Field wiring is shown in figure 59.
- 3-The warm-up kit can only be applied to GCS16 units with economizer.

WARNING - CONNECT ONLY RELAY KITS DESIGNED FOR THIS CONTROL SYSTEM. RELAY KITS DESIGNED FOR OTHER CONTROL SYSTEMS ARE NOT COMPATIBLE AND CONTROL DAMAGE OR FAILURE WILL RESULT. FOR EXAMPLE, A W973 RELAY KIT MUST NOT BE CONNECTED TO A ELECTROMECHANICAL THERMOSTAT CONTROL SYSTEM.

WARNING - BE CAREFUL TO CONNECT RELAY KITS TO THE PROPER JACK AND PLUG IN THE GCS16 BLOWER COMPARTMENT. REFER TO WIRING DIAGRAM. IMPROPER CONNECTION WILL CAUSE CONTROL FAILURE.

The warm-up kit mounts in the control mounting area of the GCS16 blower compartment. No wiring is required. Jumper plug P3 is removed and discarded. Warm-up kit harness plug P8 connects directly into jack J3 in the blower compartment. Warm-up kit harness jack J8 connects to economizer harness plug P4.

Operation Sequence:

NOTE-This operation sequence emphasizes warm-up kit operation. Unit diagram has been omitted.

- 1- When relay K41 is energized during normal operation, the economizer functions normally and is locked in until night setback.
 - 2- Economizer outdoor air dampers drive full closed anytime blower B3 is not operating.
- Night Setback:**
- 3- Time clock CMC3-1 should be adjusted so that clock contacts remain closed during hours when the building is not occupied. The contacts are set to open shortly (usually 1 hour) before the building is to be occupied.
 - 4- When clock contacts close, relay K11 (not shown) in the economizer and K42 in the warm-up kit are energized.

- 5- Contacts K11-1 open to disconnect power to thermostat S1. K11-2 (not shown) open to drive the dampers full closed.
 - 6- Contacts K42-1 open to disengage relay K41.
 - 7- When relay K41 disengages, power is disconnected to the economizer:
 - a-Contacts K41-1 open to lock-out economizer operation.
 - b-Contacts K41-2 close (not used).
 - c-Contacts K41-3 open to disconnect power to the economizer.
 - d-Contacts K41-4 open (not used).
 - 8- During unoccupied periods, K11-1 opens and S1 is disabled. When S12 closes, power is returned to S1 and the unit operates (heating demand) normally. When S12's setpoint is reached, S12 opens, S1 is disabled and unit operation stops.
 - 9- Blower operates only on demand energized by GCS16 heat relay K25 when S12 is closed.
 - 10- Thermostat S1 and economizer remain inoperable until time clock CMC3-1 contacts open.
- First Heat Demand After Night Setback (Begin Warm-Up)**
- 11- Shortly before the building is to be occupied, time clock CMC3-1 contacts open.
 - 12- Relay K42 disengages and contacts K42-1 close.
 - 13- Relay K11 disengages. Contacts K11-1 close to allow power to thermostat S1. Contacts K11-2 close to allow outdoor air dampers to open. Note that dampers remain closed until relays K3 and K41 are energized.
 - 14- Since contacts K40-1 are normally closed and contacts K42-1 have just switched closed, timer DL7 is energized. Timer DL7 is normally open and closes 30 seconds after being energized.
 - 15- If heat demand W1 reaches relay K40 before delay DL7 closes, contacts K40-1 open, delay DL7 loses power and resets and the economizer is locked out for the first heat demand by relay K41 (contacts K41-3 remain open). If heat demand W1 reaches relay K40 after delay DL7 closes, relay K41 energizes and the economizer locks in for the day until night setback.
 - 16- When first heat demand is satisfied, relay K40 disengages and relay contacts K40-1 close. Relay contacts K42-1 are already closed (clock contacts open). Time delay DL7 begins 30 sec. count. If a second heat demand W1 reaches relay K42 within 30 seconds, delay DL7 loses power and resets. If a second heat demand W1 does not reach relay K42 within 30 seconds, time delay DL7 contacts close and relay K41 energizes.
 - 17-When relay K41 energizes, the economizer is allowed to operate normally, controlled by relay K3:
 - a-Contacts K41-1 close to lock in economizer operation until night setback.
 - b-Contacts K41-2 open (not used).
 - c-Contacts K41-3 close to allow power to the economizer.
 - d-Contacts K41-4 close (not used).
 - 18- Once energized, relay K41 locks in and the economizer operates until relay K42 is energized by night setback (contacts K42-1 open to disengage relay K41).

C2-1 diagram with D5 diagram

electromechanical thermostat with modulating economizer and warm-up

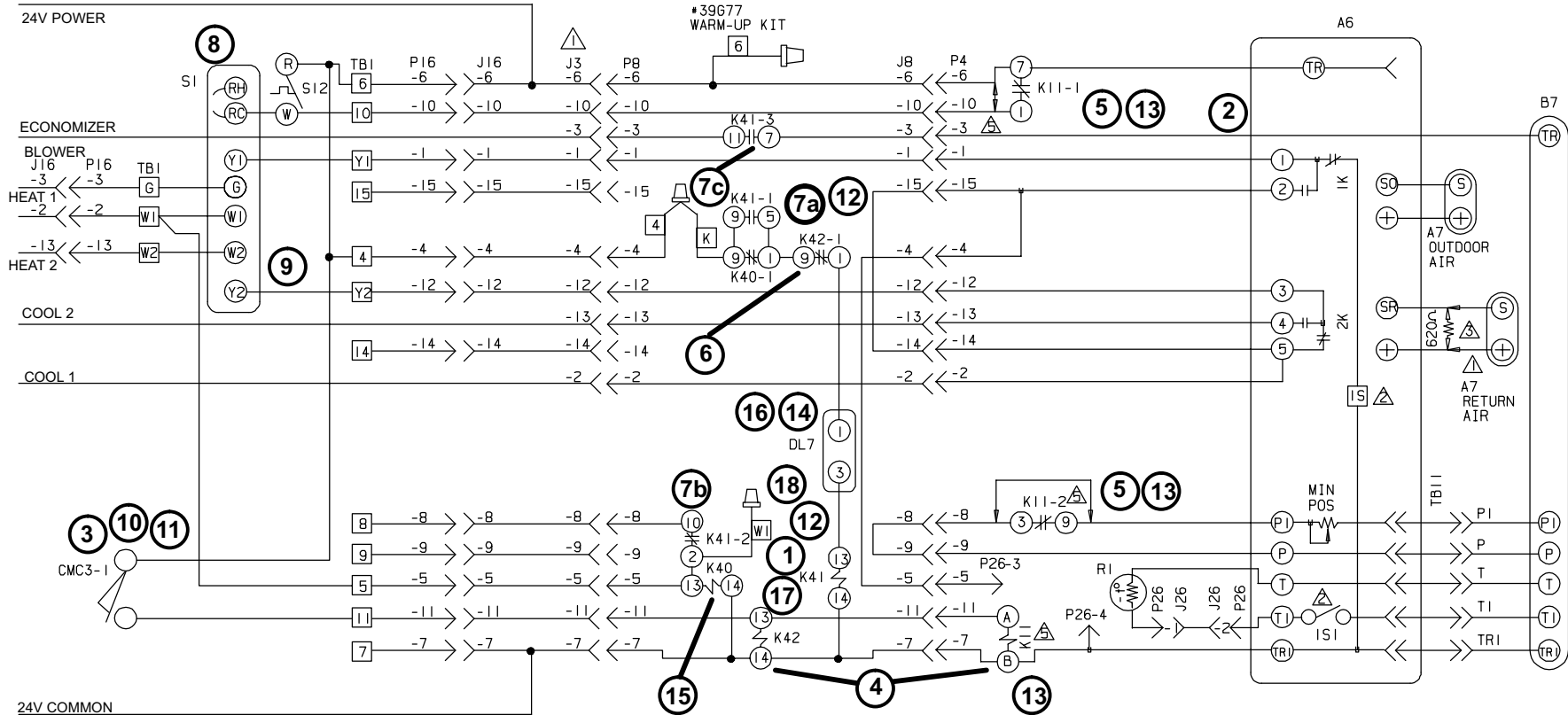

Economizer Footnotes

- △ OPTIONAL-SECOND A7 INSTALLED IN RETURN AIR PROVIDES DIFFERENTIAL ENTHALPY CONTROL
- △ WHEN IS RECEIVES POWER, ISI CLOSSES. △ WHEN W7400 CONTROL IS USED, REMOVE J26 JUMPER AND INSTALL J28. J28 AND K7 RELAY ARE PART OF W7400 KIT (74611)
- △ FACTORY INSTALLED 620 OHM, 1 WATT, 5% RESISTOR. REMOVE WHEN SECOND A7 SENSOR IS INSTALLED TO PROVIDE DIFFERENTIAL ENTHALPY CONTROL
- △ K11 NITE RELAY MAY NOT BE PART OF ECONOMIZERS ON UNITS BELOW 7.5T CAPACITY

Thermostat Footnotes

- △ J3 MAXIMUM LOAD 20VA 24VAC CLASS II

KEY	DESCRIPTION	KEY	DESCRIPTION
CMC3-1	timer-clock	A6	control-enthalpy W7459A
DL7	delay-readout	A7	sensor-enthalpy
J3	jack-economizer	B7	motor-damper
J8	jack-warm up kit	J26	jack-enthalpy
J16	jack-unit	J28	jack-W7400
K40-1	relay-warm up kit+ht latch	K7-1	relay-W7400
K41-1,2,3,4	relay-warm up kit+latch	K11-1,2	relay-nite setback
K42-1	relay-warm up kit+clock	P4	plug-economizer
P8	plug-warm up kit	P26	plug-enthalpy
P16	plug-unit	R1	sensor-supply air
S1	thermostat-room	TBII	strip-terminal
S12	thermostat-nite		
TB1	block-terminal (low volt)		

KEY	DESCRIPTION	KEY	DESCRIPTION
CMC3-1	timer-clock	A6	control-enthalpy W7459A
DL7	delay-readout	A7	sensor-enthalpy
J3	jack-economizer	B7	motor-damper
J8	jack-warm up kit	J26	jack-enthalpy
J16	jack-unit	J28	jack-W7400
K40-1	relay-warm up kit+ht latch	K7-1	relay-W7400
K41-1,2,3,4	relay-warm up kit+latch	K11-1,2	relay-nite setback
K42-1	relay-warm up kit+clock	P4	plug-economizer
P8	plug-warm up kit	P26	plug-enthalpy
P16	plug-unit	R1	sensor-supply air
S1	thermostat-room	TBII	strip-terminal
S12	thermostat-nite		
TB1	block-terminal (low volt)		

LENNOX Industries Inc. WIRING DIAGRAM 8/87

ACCESS-COMBINATION UNITS-ROOFTOP

THERMOSTAT SECTION FOR
GCS,CHA,CHP11 & 16
SERIES UNITS WITH WARM UP KIT

THERMOSTAT SECTION-C2-1

Supersedes Form No. New Form No.

LENNOX Industries Inc. WIRING DIAGRAM 4/89

ACCESS-COMBINATION UNITS-ROOFTOP

REMD16M EMDH16M
REMD11M EMD17-95/135
(MODULATING ECONOMIZER)

ECONOMIZER-SECTION D5

Supersedes Form No. New Form No.

Litho U.S.A.

Litho U.S.A.

C2-1 DIAGRAM WITH D5 DIAGRAM

Electromechanical Thermostat with Modulating Economizer and Warm-up

7-C2-1 Section with D5 Section

An optional feature of the REMD16M and EMDH16M Economizer is a warm-up kit which holds economizer outdoor air dampers closed during night heat operation and while the GCS16 is warming the building after night setback. The warm-up kit temporarily disables the economizer (outdoor dampers are held closed) during morning warm-up to keep cool outside air from being mixed with return air. Once the temperature setpoint is reached, the economizer is allowed to operate normally (outdoor air dampers open to minimum position to allow required minimum air exchange).

NOTE - In order to understand how optional controls affect operation of the GCS16, you must first read and understand how all the GCS16 components work.

NOTE -

- 1-The warm-up kit requires the use of optional time clock CMC3-1.
- 2-Optional field installed night relay K11 (may or may not be factory installed in economizer) and night thermostat S12 are also required.
- 3-The warm-up kit can only be applied to GCS16's with economizer.

WARNING - CONNECT ONLY RELAY KITS DESIGNED FOR THIS CONTROL SYSTEM. RELAY KITS DESIGNED FOR OTHER CONTROL SYSTEMS ARE NOT COMPATIBLE AND CONTROL DAMAGE OR FAILURE WILL RESULT. FOR EXAMPLE, A W973 RELAY KIT MUST NOT BE CONNECTED TO A ELECTROMECHANICAL THERMOSTAT CONTROL SYSTEM.

WARNING - BE CAREFUL TO CONNECT RELAY KITS TO THE PROPER JACK AND PLUG IN THE GCS16 BLOWER COMPARTMENT. REFER TO WIRING DIAGRAM. IMPROPER CONNECTION WILL CAUSE CONTROL FAILURE.

The warm-up kit mounts in the control mounting area of the GCS16 blower compartment. No wiring is required. Jumper plug P3 is removed and discarded. Warm-up kit harness plug P8 connects directly into jack J3 in the blower compartment. Warm-up kit harness jack J8 connects to economizer harness plug P4.

Operation Sequence:

NOTE-This operation sequence emphasizes warm-up kit operation. Unit diagram has been omitted.

- 1- When relay K41 is energized during normal operation, the economizer functions normally and is locked in until night setback.
- 2- Economizer outdoor air dampers drive full closed anytime blower B3 is not operating.

Night Setback:

- 3- Time clock CMC3-1 should be adjusted so that clock contacts remain closed during hours when the building is not occupied. The contacts are set to open shortly (usually 1 hour) before the building is to be occupied.
- 4- When clock contacts close, relay K11 in the economizer and K42 in the warm-up kit are energized.

- 5- Contacts K11-1 open to disconnect power to thermostat S1. K11-2 contacts open to drive the dampers full closed.
- 6- Contacts K42-1 open to disengage relay K41.
- 7- When relay K41 disengages, power is disconnected to the economizer:
 - a-Contacts K41-1 open to lock out economizer operation.
 - b-Contacts K41-2 close (not used).
 - c-Contacts K41-3 open to disconnect power to the economizer.
 - d-Contacts K41-4 open (not used).
- 8- During unoccupied periods, K11-1 opens and S1 is disabled. When S12 closes, power is returned to S1 and the unit operates (heating demand) normally. When S12's setpoint is reached, S12 opens, S1 is disabled and unit operation stops.
- 9- Blower operates only on demand energized by GCS16 heat relay K25 when S12 is closed.
- 10- Thermostat S1 and economizer remain inoperable until time clock CMC3-1 contacts open.
First Heat Demand After Night Setback (Begin Warm-Up)
- 11- Shortly before the building is to be occupied, time clock CMC3-1 contacts open.
- 12- Relay K42 disengages and contacts K42-1 close.
- 13- Relay K11 disengages. Contacts K11-1 close to allow power to thermostat S1. Contacts K11-2 close to allow outdoor air dampers to open. Note that dampers remain closed until relays K3 and K41 are energized.
- 14- Since contacts K40-1 are normally closed and contacts K42-1 have just switched closed, timer DL7 is energized. Timer DL7 is normally open and closes 30 sec. after being energized.
- 15- If heat demand W1 reaches relay K40 before delay DL7 closes, contacts K40-1 open, delay DL7 loses power and resets and the economizer is locked-out for the first heat demand by relay K41 (contacts K41-3 remain open). If heat demand W1 reaches relay K40 after delay DL7 closes, relay K41 energizes and the economizer locks in for the day until night setback.
- 16- When first heat demand is satisfied, relay K40 disengages and relay contacts K40-1 close. Relay contacts K42-1 are already closed (clock contacts open). Time delay DL7 begins 30 second count. If a second heat demand W1 reaches relay K42 within 30 second, delay DL7 loses power and resets. If a second heat demand W1 does not reach relay K42 within 30 sec., time delay DL7 contacts close and relay K41 energizes.
- 17- When relay K41 energizes, the economizer is allowed to operate normally, controlled by relay K3:
 - a-Contacts K41-1 closes to lock in economizer operation until night setback.
 - b-Contacts K41-2 opens (not used).
 - c-Contacts K41-3 closes to allow power to the economizer.
 - d-Contacts K41-4 closes (not used).
- 18- Once energized, relay K41 locks in and the economizer operates until relay K42 is energized by night setback (contacts K42-1 open to disengage relay K41).

C11-1 diagram *electromechanical thermostat with night setback relay kit*

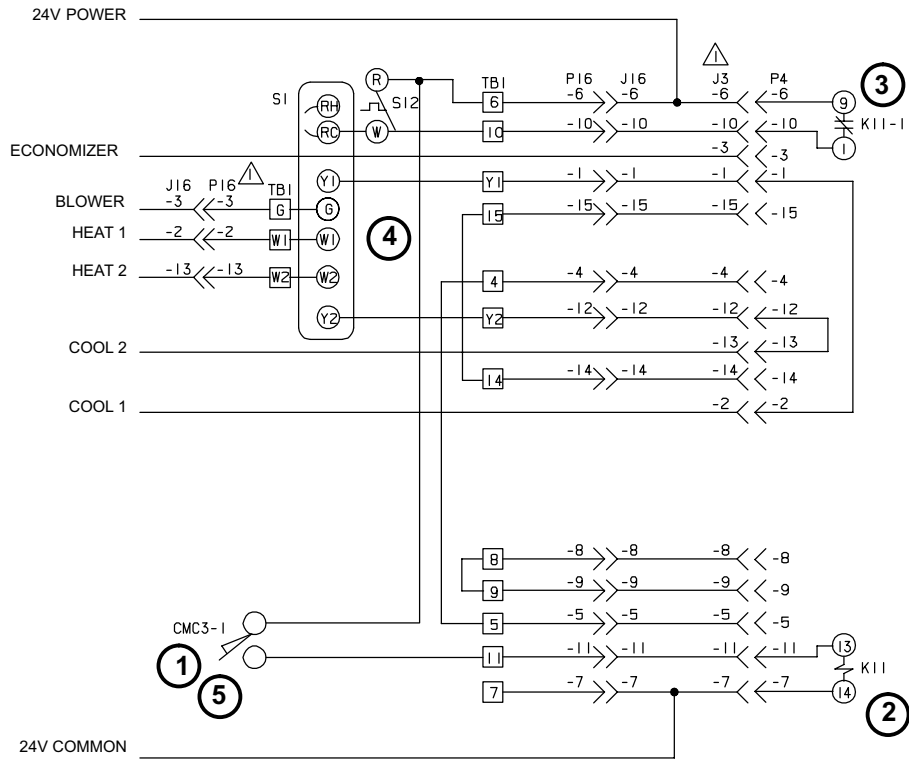

⚠ J3 MAXIMUM LOAD 20VA 24VAC CLASS II

KEY	DESCRIPTION
	COMPONENT
CMC3-1	timer-clock
J3	jack-economizer
J16	jack-unit
K11-I	relay-nite setback
P4	plug-nite kit
P16	plug-unit
S1	thermostat-room
S2	thermostat-nite
TB1	block-terminal(low volt)

LENNOX ® Industries Inc.	WIRING DIAGRAM	2/87 5/87
ACCESS-COMBINATION UNITS-ROOFTOP		
ELECTROMECHANICAL THERMOSTAT		
FOR GCS, CHA, CHP11 & 16		
SERIES UNITS WITH NITE KIT		
THERMOSTAT SECTION-C11-1		
Supersedes Form No.	New Form No.	

Litho U.S.A.

C11 DIAGRAM

Electromechanical Thermostat with Night Setback Thermostat and without Economizer

8-C11 SECTION (electromechanical thermostat with night relay kit)

Optional night (setback relay) kit allows GCS16 units without economizer (REMD16 or EMDH16) to automatically setback the thermostat to reduce energy consumption during times when the building is not occupied. The night kit achieves this by electrically disconnecting thermostat S1 and connecting a night thermostat during periods when the building is not occupied. The night thermostat can then be adjusted with a lower setpoint as needed for unoccupied heating.

NOTE - In order to understand how these optional controls affect the operation of the GCS16, you must first understand how all GCS16 components work. Refer to the operation sequence for basic unit operation.

WARNING - CONNECT ONLY RELAY KITS DESIGNED FOR THIS CONTROL SYSTEM. RELAY KITS DESIGNED FOR OTHER CONTROL SYSTEMS ARE NOT COMPATIBLE AND CONTROL DAMAGE OR FAILURE WILL RESULT. FOR EXAMPLE, ON UNITS USING AN ELECTROMECHANICAL THERMOSTAT WITHOUT AN ECONOMIZER, A WARM-UP KIT MUST NOT BE CONNECTED. ONLY THE OPTIONAL NIGHT KIT CAN BE USED.

WARNING - BE CAREFUL TO CONNECT RELAY KITS TO THE PROPER JACK AND PLUG IN THE GCS16 BLOWER COMPARTMENT. REFER TO WIRING DIAGRAM. IMPROPER CONNECTION WILL CAUSE CONTROL FAILURE.

NOTE -

- 1-The night kit accessory requires the use of optional time clock CMC3-1/ and optional night thermostat.*
- 2-The time clock accessory requires the use of field wired night kit relay K11.*

No wiring is required for installing the kit. Jumper plug P3 is removed from the unit and discarded. Night kit harness plug P4 connects directly into jack J3 in the unit blower compartment (see figure 93).

Night Setback:

NOTE-This operation sequence emphasizes night-kit operation. Unit diagram has been omitted.

- 1- Time clock CMC3-1 contacts are open during normal operation of the unit when the building is occupied. All cooling and heating stages function normally.
- 2- When clock contacts switch closed (when the building is not occupied) relay K11 is energized.
- 3- When relay K11 is energized, contacts K11-1 open disconnecting power to thermostat S1. Thermostat S1 remains disconnected until clock contacts open (usually 1 hour before the building is to be occupied). During the time thermostat S1 is disconnected, night thermostat S12, which has been set at a lower setpoint than S1, controls operation of the unit.
During unoccupied periods, K11-1 opens and S1 is disabled. When S12 closes, power is supplied to S1 and the unit operates normally. When S12's setpoint opens, S1 is disabled and unit operation stops.
- 4- The blower operates as normal, controlled by heating demand when S12 is closed.
- 5- Shortly before the building is to be occupied, time clock CMC3-1 contacts open and relay K11 is de-energized. Contacts K11-1 then close and power is restored to thermostat S1.

C3 diagram Flexstat thermostat

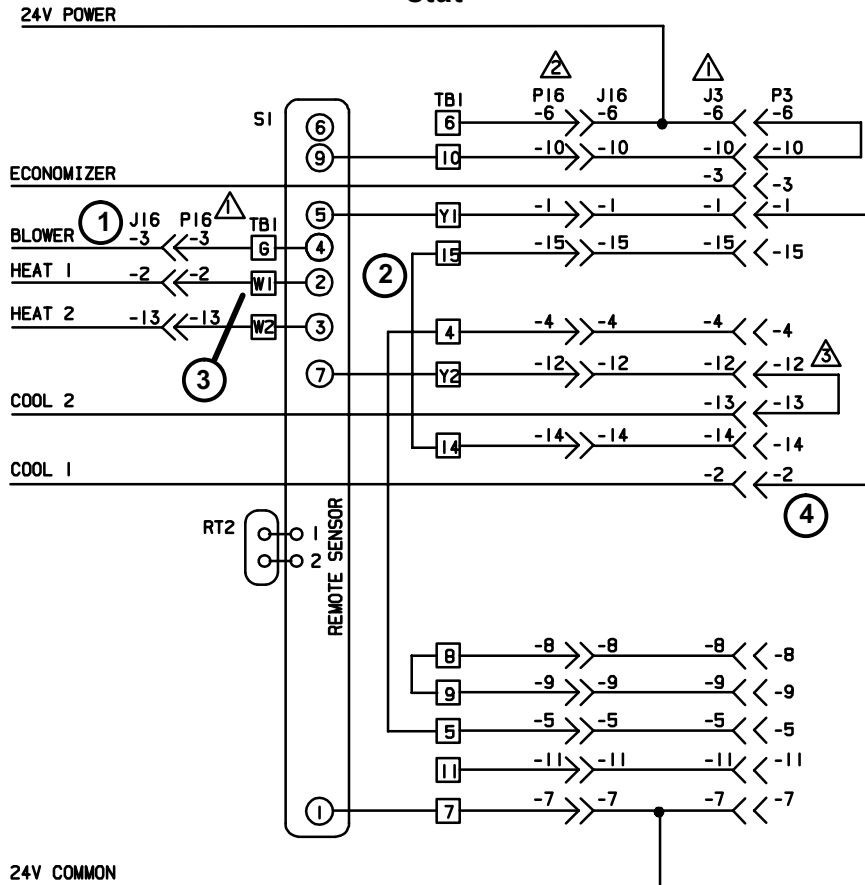

- ⚠ P3-12 TO P3-13 JUMPER IS NOT USED ON LATER CHA15 SERIES
- ⚠ P16 AND J16 ARE NOT USED ON 15 SERIES
- ⚠ J3 MAXIMUM LOAD 20VA 24VAC CLASS II

KEY	DESCRIPTION
J3	jack-economizer
J16	jack-unit (16 SERIES)
P3	plug-jumper
P16	plug-unit (16 SERIES)
RT2	sensor-remote (optional)
S1	thermostat-room L2F-N
TBI	block-terminal (low volt)

LENNOX Industries Inc. WIRING DIAGRAM 3/88

ACCESS-COMBINATION UNITS-ROOFTOP

ELECTRONIC THERMOSTAT
11, 15 & 16 SERIES
2 COOL, 2 HEAT (FLEXSTAT)

THERMOSTAT SECTION C3

Supersedes Form No. _____ New Form No. _____

Litho U.S.A.

C5 diagram Prostat thermostat

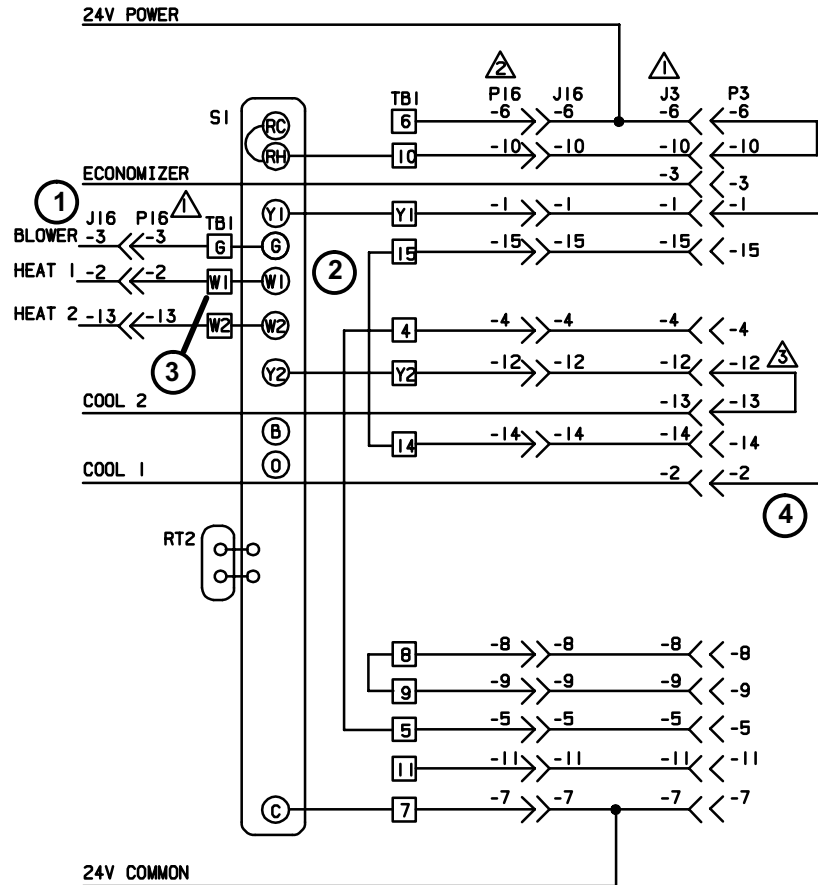

- ⚠ P3-12 TO P3-13 JUMPER IS NOT USED ON LATER CHA15 SERIES
- ⚠ P16 AND J16 ARE NOT USED ON 15 SERIES
- ⚠ J3 MAXIMUM LOAD 20VA 24VAC CLASS II

KEY	DESCRIPTION
J3	jack-economizer
J16	jack-unit (16 SERIES)
P3	plug-jumper
P16	plug-unit (16 SERIES)
RT2	sensor-remote (optional)
S1	thermostat-room T5010
TBI	block-terminal (low volt)

LENNOX Industries Inc. WIRING DIAGRAM 5/87

ACCESS-COMBINATION UNITS-ROOFTOP

ELECTRONIC THERMOSTAT
11, 15 & 16 SERIES
2 COOL, 2 HEAT (PROSTAT)

THERMOSTAT SECTION C5

Supersedes Form No. _____ New Form No. _____

Litho U.S.A.

C3 DIAGRAM and C5 DIAGRAM

Flexstat (C3) and Prostat (C5) without Economizer or Warm-Up

C-ELECTRONIC THERMOSTAT SYSTEMS

1-C3,C5 Sections

Optional Flexstat C3-1/Prostat C5-1 programmable thermostats allow GCS16's without economizer to automatically setback or setup setpoints for unoccupied periods as well as control setpoints more precisely than electromechanical thermostats.

NOTE - In order to understand how these optional controls affect the operation of the GCS16, you must first understand how all GCS16 components work. Refer to the operation sequence for basic unit operation.

NOTE - These thermostats have a built-in clock for controlling setback. Optional time clock CMC3-1, night thermostat and night relay kit are not needed and are not compatible.

IMPORTANT - Flexstat model L2F has been superseded by Flexstat L2F-N. Terminal designation on the two controls are different. This sequence of operation describes models L2F-N. Refer to Table 23 for more information.

TABLE 23

FLEXSTAT/PROSTAT TERMINAL CONNECTIONS			
GCS16 TERMINAL OR PIGTAIL	FLEXSTAT MODEL L2F TERMINAL	FLEXSTAT MODEL L2F-N TERMINAL	PROSTAT TERMINAL
G	5	4	G
Y1	6	5	Y1
Y2	4	7	Y2
W1	3	2	W1
W2	9	3	W2
10	8	8, 9	R _H , R _C
7	2	1	C

Operation Sequence:

1- The GCS16 with Flexstat/Prostat is designed so that the fan switch in the thermostat should be left in the ECONO mode (ON mode in the Flexstat) at all times. This allows the blower to be controlled by terminal G in the Prostat (terminal 4 in the Flexstat). The blower operates continuously during occupied periods and intermittently during unoccupied periods.

NOTE - Flexstats ONLY: If slide switch number 7 on back of model L2F-N (slide switch number 5 on back of L2F) is switched to ON position, the blower operates continuously during occupied periods and automatically cycles during unoccupied periods. If this slide switch is switched to OFF position, the blower operates normally during unoccupied periods, controlled by the ON/AUTO button on the face of the control.

2- During a heating demand when the building is not occupied, the blower is activated only when a heating demand passes through relay K25 in the GCS16. During a cooling demand when the building is not occupied, the blower is activated through terminal G in the Prostat (terminal 4 in Flexstat).

3- Heating demand W1 directly energizes the heat section of the GCS16.

4- Cooling demand Y1 is routed through plug P3 to activate the cooling circuit of the GCS16 directly.

C3 diagram with D8 diagram Flexstat with three-position economizer

24V POWER

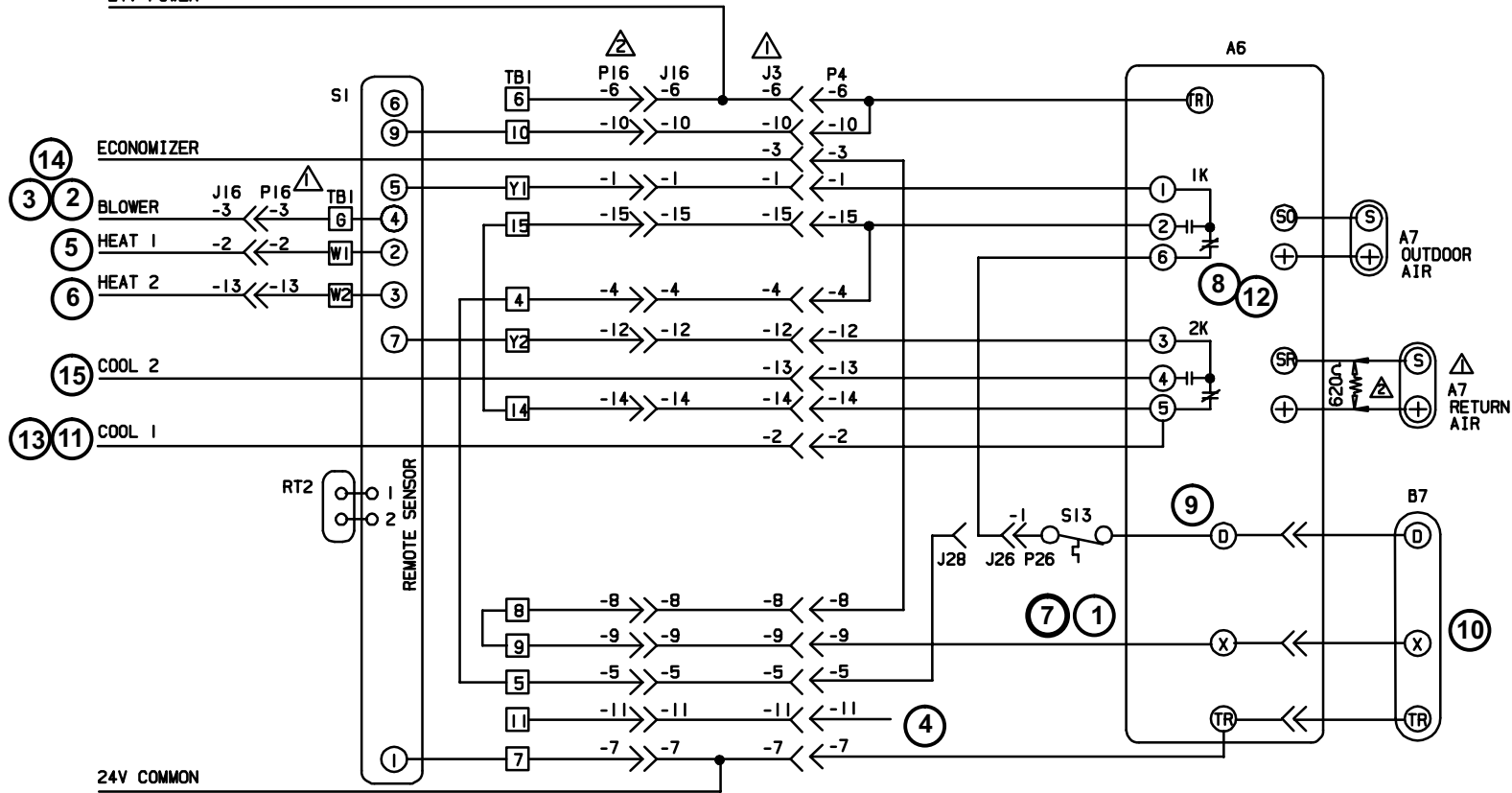

24V COMMON

LENNOX Industries Inc. WIRING DIAGRAM 3/88	
ACCESS-COMBINATION UNITS-ROOFTOP	
ELECTRONIC THERMOSTAT	
11, 15 & 16 SERIES	
2 COOL, 2 HEAT (FLEXSTAT)	
THERMOSTAT SECTION C3	
Supersedes Form No.	New Form No.

Litho U.S.A.

KEY	DESCRIPTION
J3	jack-economizer
J16	jack-unit (16 SERIES)
P3	plug-jumper
P16	plug-unit (16 SERIES)
RT2	sensor-remote (optional)
S1	thermostat-room L2F-N
TBI	block-terminal (low volt)

Thermostat Footnotes

- ⚠ P3-12 TO P3-13 JUMPER IS NOT USED ON LATER CHA15 SERIES
- ⚠ P16 AND J16 ARE NOT USED ON 15 SERIES
- ⚠ J3 MAXIMUM LOAD 20VA 24VAC CLASS II

LENNOX Industries Inc. WIRING DIAGRAM 4/89	
ACCESS-COMBINATION UNITS-ROOFTOP	
REMD16 SERIES	
EMDH16 SERIES	
(3 POSITION)	
ECONOMIZER-SECTION D8	
Supersedes Form No.	New Form No.

Litho U.S.A.

KEY	DESCRIPTION
A6	control-enthalpy (W7459C)
A7	sensor-enthalpy
B7	motor-damper
J26	jack-enthalpy
J28	jack-W7400
P4	plug-economizer
P26	plug-enthalpy
S13	thermostat-discharge air

Economizer Footnotes

- ⚠ OPTIONAL-SECOND A7 INSTALLED IN RETURN AIR PROVIDES DIFFERENTIAL ENTHALPY CONTROL
- ⚠ FACTORY INSTALLED 620 OHM, 1 WATT, 5% RESISTOR. REMOVE WHEN SECOND A7 SENSOR IS INSTALLED TO PROVIDE DIFFERENTIAL ENTHALPY CONTROL

C5 diagram with D8 diagram Prostat with three-position economizer

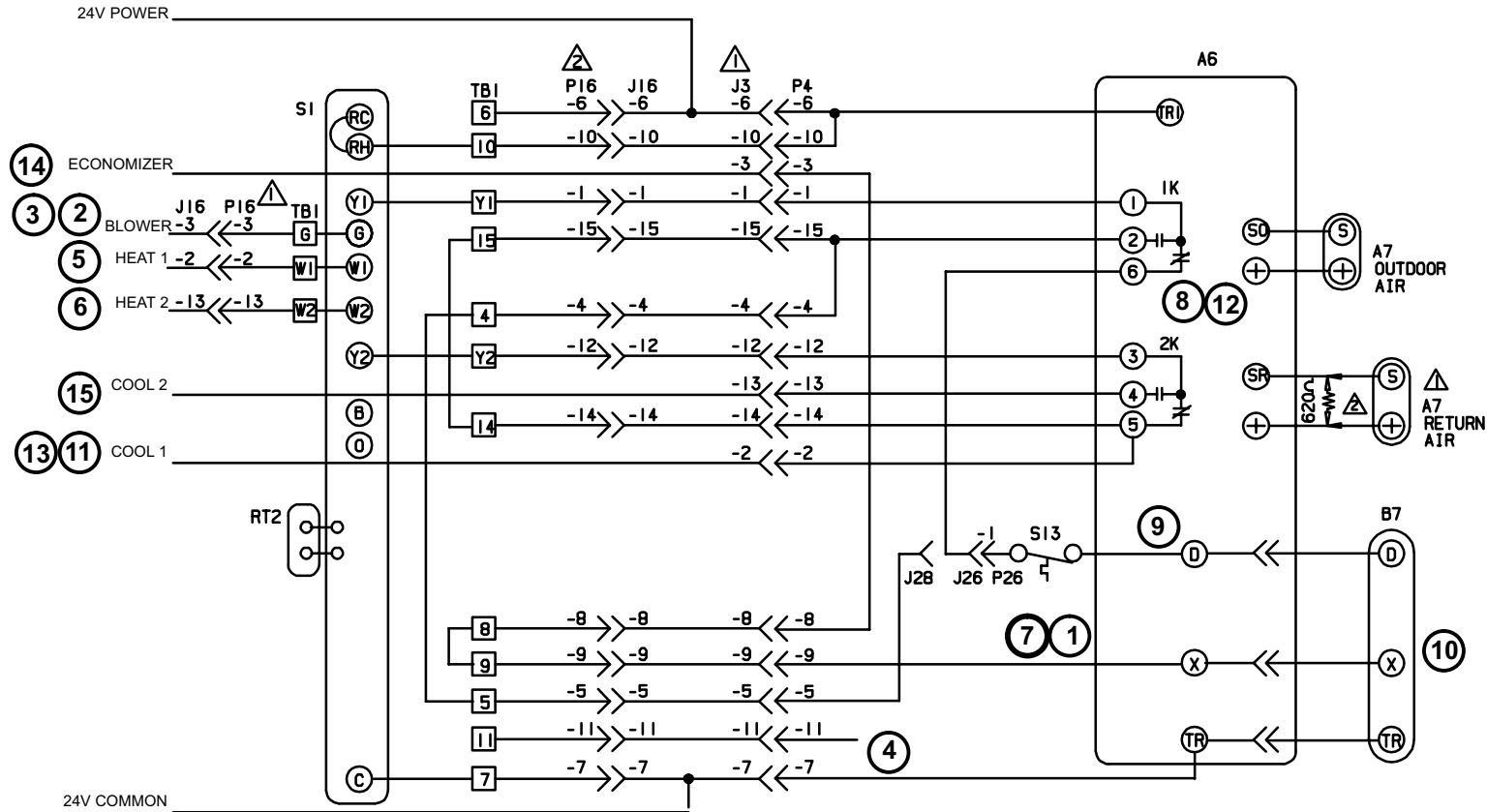

Thermostat Footnotes

- ⚠ P3-12 TO P3-13 JUMPER IS NOT USED ON LATER CHAI5 SERIES
- ⚠ P16 AND J16 ARE NOT USED ON 15 SERIES
- ⚠ J3 MAXIMUM LOAD 20VA 24VAC CLASS II

Economizer Footnotes

- ⚠ OPTIONAL-SECOND A7 INSTALLED IN RETURN AIR PROVIDES DIFFERENTIAL ENTHALPY CONTROL
- ⚠ FACTORY INSTALLED 620 OHM, 1 WATT, 5% RESISTOR. REMOVE WHEN SECOND A7 SENSOR IS INSTALLED TO PROVIDE DIFFERENTIAL ENTHALPY CONTROL

LENNOX Industries Inc. WIRING DIAGRAM 5/87

ACCESS-COMBINATION UNITS-ROOFTOP

ELECTRONIC THERMOSTAT
11, 15 & 16 SERIES
2 COOL, 2 HEAT (PROSTAT)

THERMOSTAT SECTION C5

Supersedes Form No. _____ New Form No. _____

KEY	DESCRIPTION
J3	jack-economizer
J16	jack-unit (16 SERIES)
P3	plug-jumper
P16	plug-unit (16 SERIES)
RT2	sensor-remote (optional)
S1	thermostat-room T5010
TB1	block-terminal (low volt)

KEY	DESCRIPTION
A6	control-enthalpy (W7459C)
A7	sensor-enthalpy
B7	motor-damper
J26	jack-enthalpy
J28	jack-W7400
P4	plug-economizer
P26	plug-enthalpy
S13	thermostat-discharge air

LENNOX Industries Inc. WIRING DIAGRAM 4/89

ACCESS-COMBINATION UNITS-ROOFTOP

REMD16 SERIES
EMDH16 SERIES
(3 POSITION)

ECONOMIZER-SECTION D8

Supersedes Form No. _____ New Form No. _____

C3 or C5 DIAGRAM WITH D8 DIAGRAM

Flexstat or Prostat with Three-position Economizer

2-C3 or C5 Section with D5 Section

An EMDH16 or REMD16 economizer may be applied to a GCS16 with Flexstat or Prostat. Both are programmable thermostat which allow GCS16 units to automatically setback or set-up setpoints for unoccupied periods as well as control setpoints more precisely than electro-mechanical thermostat. With the economizer added, the Flexstat is capable of directly controlling the operation of outdoor air dampers.

NOTE - In order to understand how these optional controls affect the operation of the GCS16, you must first understand how all GCS16 components work. Refer to the operation sequence for basic unit operation.

NOTE - These thermostats have a built-in clock for controlling setback. Optional time clock CMC3-1, night thermostat and night relay kit are not needed and are not compatible.

No wiring is required when connecting an economizer. Economizer plug P4 connects to GCS16 jack J3 in the unit blower compartment. Jumper-plug P3 is removed and discarded. See figure 92.

IMPORTANT - Flexstat model L2F has been superseded by Flexstat L2F-N. Terminal designation on the two controls are different. This sequence of operation describes models L2F-N. Refer to Table 23 for more information.

Operation Sequence:

- 1- Economizer outdoor air dampers drive full closed anytime blower B6 is not operating.
- 2- The GCS16 with Flexstat or Prostat is designed so that the fan switch in the thermostat is to be left in the ON mode at all times. This allows the blower to be controlled by terminal 4 inside the Flexstat (G in Prostat). The blower operates continuously during occupied periods and intermittently (only during demand) during unoccupied periods.
NOTE - Flexstats ONLY: If slide switch number 7 on back of model L2F-N (slide switch number 5 on back of L2F) is switched to ON position, the blower operates continuously during occupied periods and automatically cycles during unoccupied periods. If this slide switch is switched to OFF position, the blower operates normally during unoccupied periods, controlled by the ON/AUTO button on the face of the control.
- 3- During a heating demand when the building is not occupied, the blower is activated only when a heating demand passes through relay K25 in the GCS16. During a cooling demand when the building is not occupied, the blower is activated through terminal 4 in the Flexstat (G in Prostat).
- 4- Setback relay K11 (not furnished) is not used in this application. Contacts K11-1 and K11-2 (if installed) are normally closed and should remain closed at all times.

Heating Demand:

- 5- Heating demand (Prostat terminal W1 - Flexstat terminal 2) activates the GCS16 heating section directly.
- 6- Additional heating demand (Prostat terminal W2 - Flexstat terminal 3) is not used in this application.
- 7- Economizer outdoor air dampers remain at the mid (minimum) position allowed by the minimum positioner during blower operation.

Cooling Demand Enthalpy Low:

- 8- Enthalpy control internal relays switch to close a circuit from 1k terminal 1 to 6 and from 2K terminal 3 to 5.
- 9- Initial cooling demand (Prostat terminal Y1 - Flexstat terminal 5) is routed through enthalpy control terminals 1 and 6 and through discharge air thermostat S13 to energize enthalpy control terminal D and damper motor terminal D. 24VAC applied between damper motor terminals D and T energizes the damper motor and the outdoor air dampers open fully.
- 10- Economizer outdoor air dampers drive full open during blower B3 operation (anytime there is a cooling demand) to provide first stage cooling. Outdoor air dampers drive full closed anytime blower B3 is not operating.
- 11- Additional cooling demand (Prostat terminal Y2 - Flexstat terminal 7) is routed through enthalpy control terminals 1 and 2 to energize the compressor. The compressor provides all additional cooling.

Cooling Demand Enthalpy High:

- 12- Enthalpy control internal relays switch to close a circuit from 1k terminal 1 to 2 and from 2K terminal 3 to 4. Outdoor air dampers close. Dampers open to minimum position during blower B3 operation.
- 13- Cooling demand (Prostat terminal Y1 - Flexstat terminal 5) is routed through enthalpy control terminals 1 and 2 and terminal 5 to energize the compressor. The compressor handles all cooling demand.
- 14- Blower demand (Prostat terminal G - Flexstat terminal 4) energizes blower relay K3 in the unit. Contacts K3-1 close to energize the blower and contacts K3-2 close to energize the economizer. When 24VAC is applied between enthalpy control terminals X and T, the outdoor air dampers open to mid (minimum) position. Dampers remain open when blower B3 is operating and close when B3 is not operating.
- 15- Increased cooling demand (Prostat terminal Y2 - Flexstat terminal 7) is not used in this application.

C3 diagram with D5 diagram Flexstat with modulating economizer

24V POWER

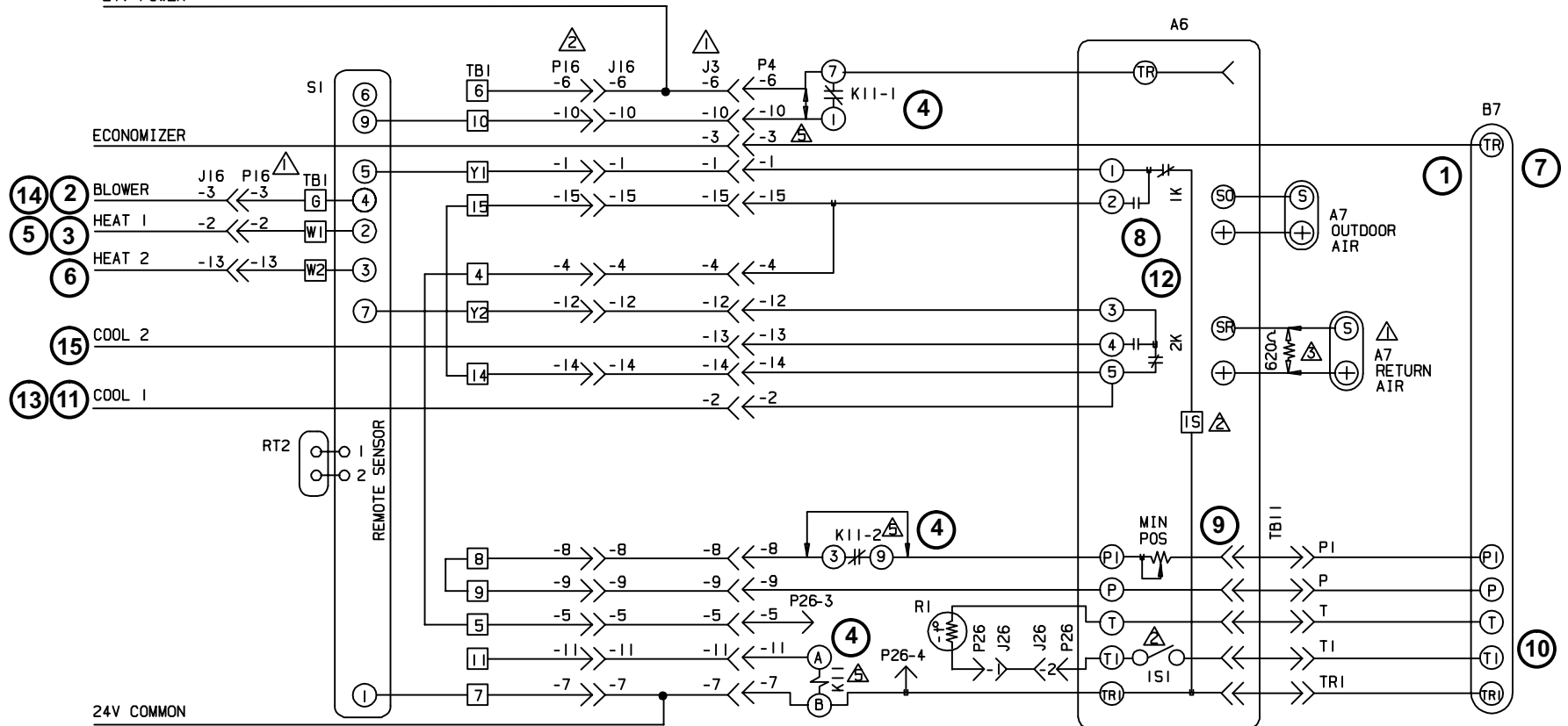

24V COMMON

LENNOX Industries Inc. WIRING DIAGRAM 3/88

ACCESS-COMBINATION UNITS-ROOFTOP

ELECTRONIC THERMOSTAT
11, 15 & 16 SERIES
2 COOL, 2 HEAT (FLEXSTAT)

THERMOSTAT SECTION C3

Supersedes Form No. _____ New Form No. _____

Litho U.S.A.

LENNOX Industries Inc. WIRING DIAGRAM 4/89

ACCESS-COMBINATION UNITS-ROOFTOP

REMD16M EMDH16M
REMD11M EMD17-95/135
(MODULATING ECONOMIZER)

ECONOMIZER-SECTION D5

Supersedes Form No. _____ New Form No. _____

KEY	DESCRIPTION
	COMPONENT
A6	control-enthalpy W7459A
A7	sensor-enthalpy
B7	motor-damper
J26	jack-enthalpy
J28	jack-W7400
K7,-1	relay-W7400
K11,-1,2	relay-nite setback
P4	plug-economizer
P26	plug-enthalpy
R1	sensor-supply air
TB11	strip-terminal

KEY	DESCRIPTION
	COMPONENT
J3	jack-economizer
J16	jack-unit (16 SERIES)
P3	plug-jumper
P16	plug-unit (16 SERIES)
RT2	sensor-remote (optional)
S1	thermostat-room L2F-N
TB1	block-terminal (low volt)

- Thermostat Footnotes*
- ⚠ P3-12 TO P3-13 JUMPER IS NOT USED ON LATER CHA15 SERIES
 - ⚠ P16 AND J16 ARE NOT USED ON 15 SERIES
 - ⚠ J3 MAXIMUM LOAD 20VA 24VAC CLASS II

- Economizer Footnotes*
- ⚠ OPTIONAL-SECOND A7 INSTALLED IN RETURN AIR PROVIDES DIFFERENTIAL ENTHALPY CONTROL
 - ⚠ WHEN IS RECEIVES POWER, IS1 CLOSES.
 - ⚠ FACTORY INSTALLED 620 OHM, 1 WATT, 5% RESISTOR. REMOVE WHEN SECOND A7 SENSOR IS INSTALLED TO PROVIDE DIFFERENTIAL ENTHALPY CONTROL
 - ⚠ WHEN W7400 CONTROL IS USED, REMOVE J26 JUMPER AND INSTALL J28. J28 AND K7 RELAY ARE PART OF W7400 KIT (74G11)
 - ⚠ K11 NITE RELAY MAY NOT BE PART OF ECONOMIZERS ON UNITS BELOW 7.5T CAPACITY

C5 diagram with D5 diagram Prostat with modulating economizer

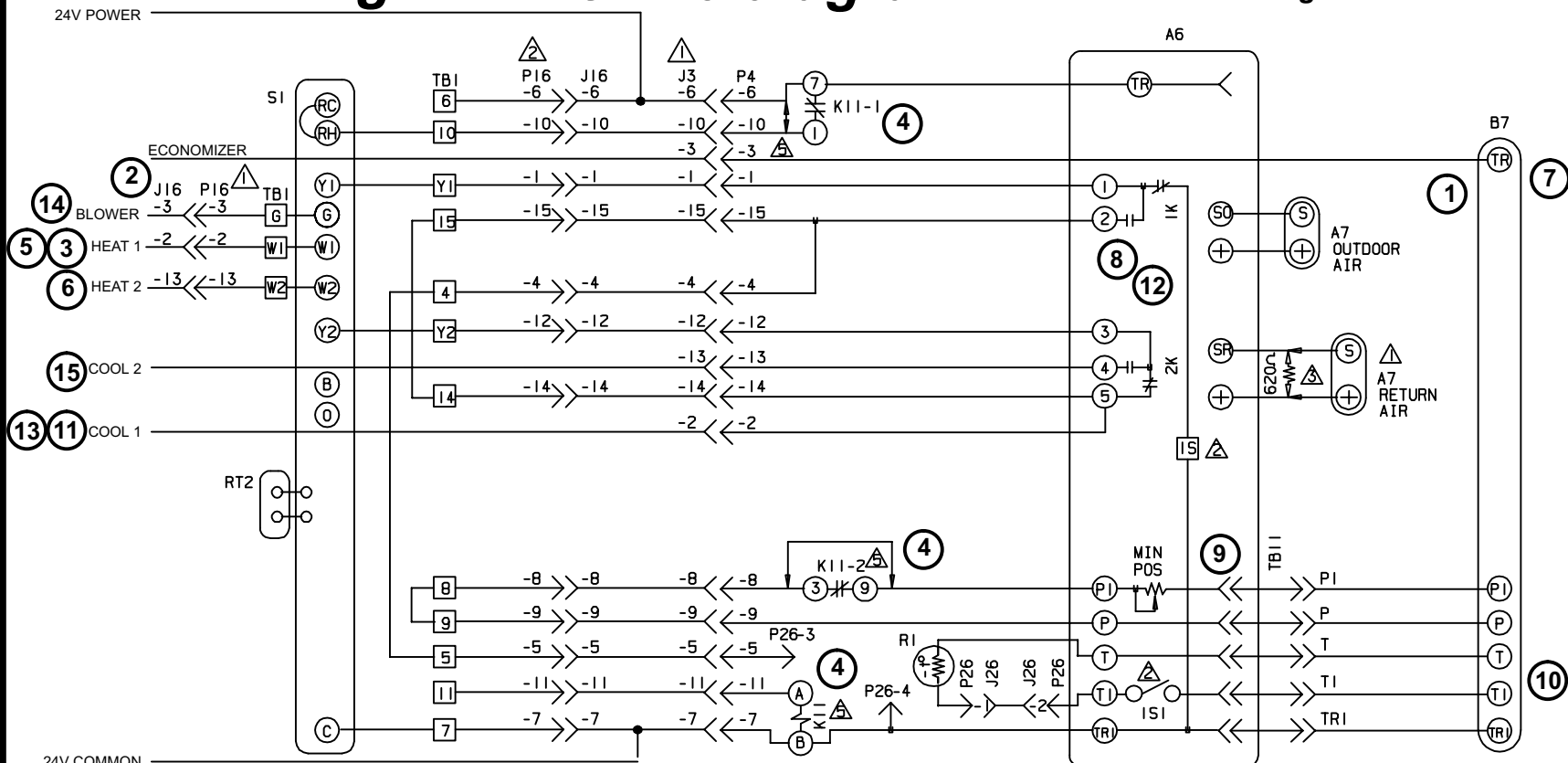

Page 103

LENNOX Industries Inc. WIRING DIAGRAM 5/87

ACCESS-COMBINATION UNITS-ROOFTOP

ELECTRONIC THERMOSTAT
11, 15 & 16 SERIES
2 COOL, 2 HEAT (PROSTAT)

THERMOSTAT SECTION C5

Supersedes Form No. _____ New Form No. _____

Litho U.S.A.

LENNOX Industries Inc. WIRING DIAGRAM 4/89

ACCESS-COMBINATION UNITS-ROOFTOP

REMD16M EMDH16M
REMD11M EMD17-95/135
(MODULATING ECONOMIZER)

ECONOMIZER-SECTION D5

Supersedes Form No. _____ New Form No. _____

KEY	DESCRIPTION	COMPONENT
A6	control-enthalpy	W7459A
A7	sensor-enthalpy	
B7	motor-damper	
J26	jack-enthalpy	
J28	jack-W7400	
K7,-1	relay-W7400	
K11,-1,2	relay-nite setback	
P4	plug-economizer	
P26	plug-enthalpy	
R1	sensor-supply air	
TB11	strip-terminal	(low volt)

KEY	DESCRIPTION	COMPONENT
J3	jack-economizer	
J16	jack-unit	(16 SERIES)
P3	plug-jumper	
P16	plug-unit	(16 SERIES)
RT2	sensor-remote	(optional)
S1	thermostat-room	T5010
TB1	block-terminal	(low volt)

- Economizer Footnotes*
- ⚠ OPTIONAL-SECOND A7 INSTALLED IN RETURN AIR PROVIDES DIFFERENTIAL ENTHALPY CONTROL
 - ⚠ WHEN IS RECEIVES POWER, ISI CLOSES.
 - ⚠ FACTORY INSTALLED 620 OHM, 1 WATT, 5% RESISTOR. REMOVE WHEN SECOND A7 SENSOR IS INSTALLED TO PROVIDE DIFFERENTIAL ENTHALPY CONTROL
 - ⚠ WHEN W7400 CONTROL IS USED, REMOVE J26 JUMPER AND INSTALL J28. J28 AND K7 RELAY ARE PART OF W7400 KIT (74G11)
 - ⚠ K11 NITE RELAY MAY NOT BE PART OF ECONOMIZERS ON UNITS BELOW 7.5T CAPACITY
- Thermostat Footnotes*
- ⚠ P3-12 TO P3-13 JUMPER IS NOT USED ON LATER CHA15 SERIES
 - ⚠ P16 AND J16 ARE NOT USED ON I5 SERIES
 - ⚠ J3 MAXIMUM LOAD 20VA 24VAC CLASS II

C3 or C5 DIAGRAM WITH D5 DIAGRAM

Flexstat or Prostat with Modulating Economizer

3-C3 or C5 Section with D5 Section

An EMDH16M or REMD16M economizer may be applied to a GCS16 with Flexstat or Prostat. Both are programmable thermostats which allow GCS16 units to automatically setback or set-up setpoints for unoccupied periods as well as control setpoints more precisely than electro-mechanical thermostat. With the economizer added, the Flexstat and Prostat are capable of directly controlling the operation of outdoor air dampers.

NOTE - In order to understand how these optional controls affect the operation of the GCS16, you must first understand how all GCS16 components work. Refer to the operation sequence for basic unit operation.

NOTE - These thermostats have a built-in clock for controlling setback. Optional time clock CMC3-1, night thermostat and night relay kit are not needed and are not compatible.

No wiring is required when connecting an economizer. Economizer plug P4 connects to GCS16 jack J3 in the unit blower compartment. Jumper-plug P3 is removed and discarded. See figure 92. Refer to Table 23 for thermostat terminal designations.

IMPORTANT - Flexstat model L2F has been superseded by Flexstat L2F-N. Terminal designation on the two controls are different. This sequence of operation describes models L2F-N. Refer to Table 24 for more information.

Operation Sequence:

- 1- Economizer outdoor air dampers drive full closed anytime blower B6 is not operating.
- 2- The Flexstat and Prostat are designed so that the fan switch in the thermostat is to be left in the ON mode at all times. This allows the blower to be controlled by terminal G inside the Prostat (4 in Flexstat). The blower operates continuously during occupied periods and intermittently (only during demand) during unoccupied periods.
NOTE - Flexstats ONLY: If slide switch number 7 on back of model L2F-N (slide switch number 5 on back of L2F) is switched to ON position, the blower operates continuously during occupied periods and automatically cycles during unoccupied periods. If this slide switch is switched to OFF position, the blower operates normally during unoccupied periods, controlled by the ON/AUTO button on the face of the control.
- 3- During a heating demand when the building is not occupied, the blower is activated only when a heating demand passes through relay K25 in the GCS16. During a cooling demand when the building is not occupied, the blower is activated through terminal G in the Prostat (4 in Flexstat).
- 4- Setback relay K11 (not furnished) is not used in this application. Contacts K11-1 and K11-2 (if installed) are normally closed and should remain closed at all times.

Heating Demand:

- 5- Heating demand (Prostat terminal W1 - Flexstat terminal 2) activates the GCS16 heating section directly.
- 6- Additional heating demand (Prostat terminal W2 - Flexstat terminal 3) is not used in this application.
- 7- Economizer outdoor air dampers remain at the minimum position allowed by the minimum positioner during blower operation.

Cooling Demand Enthalpy Low:

- 8- Enthalpy control internal relays switch to close a circuit from 1k terminal 1 to 6 and from 2K terminal 3 to 5.
- 9- Cooling demand (Prostat terminal Y1 - Flexstat terminal 5) is routed through enthalpy control terminal 1 to energize internal relay 1S. Contacts 1S1 close to energize damper motor. Outdoor air dampers open to provide 1st stage cooling.
- 10- Economizer outdoor air dampers drive full open during blower B3 operation (anytime there is a cooling demand) to provide 1st stage cooling. Outdoor air dampers drive full closed anytime blower B3 is not operating.
- 11- Additional cooling demand (Prostat terminal Y2 - Flexstat terminal 7) is routed through enthalpy control terminals 1 and 2 and through terminal 5 to energize the compressor. The compressor provides all additional cooling.

Cooling Demand Enthalpy High:

- 12- Enthalpy control internal relays switch to close a circuit from 1k terminal 1 to 2 and from 2K terminal 3 to 4. Internal relay 1S is de-energized and contacts 1S1 open. Outdoor air dampers close. Dampers open to minimum position during blower B3 operation.
- 13- Cooling demand (Prostat terminal Y1 - Flexstat terminal 5) is routed through enthalpy control terminals 1 and 2 and terminal 5 to energize the compressor. The compressor handles all cooling demand.
- 14- Blower demand (Prostat terminal G - Flexstat terminal 4) energizes blower relay K3 in the unit. Contacts K3-1 close to energize the blower and contacts K3-2 close to energize the economizer. When 24VAC is applied between damper motor terminals TR and TR1, the outdoor air dampers open to minimum position. Dampers remain open when blower B3 is operating and close when B3 is not operating.
- 15- Increased cooling demand (Prostat terminal Y2 - Flexstat terminal 7) is not used in this application.

C4 diagram with D8 diagram Flexstat with three-position economizer and warm-up

24V POWER

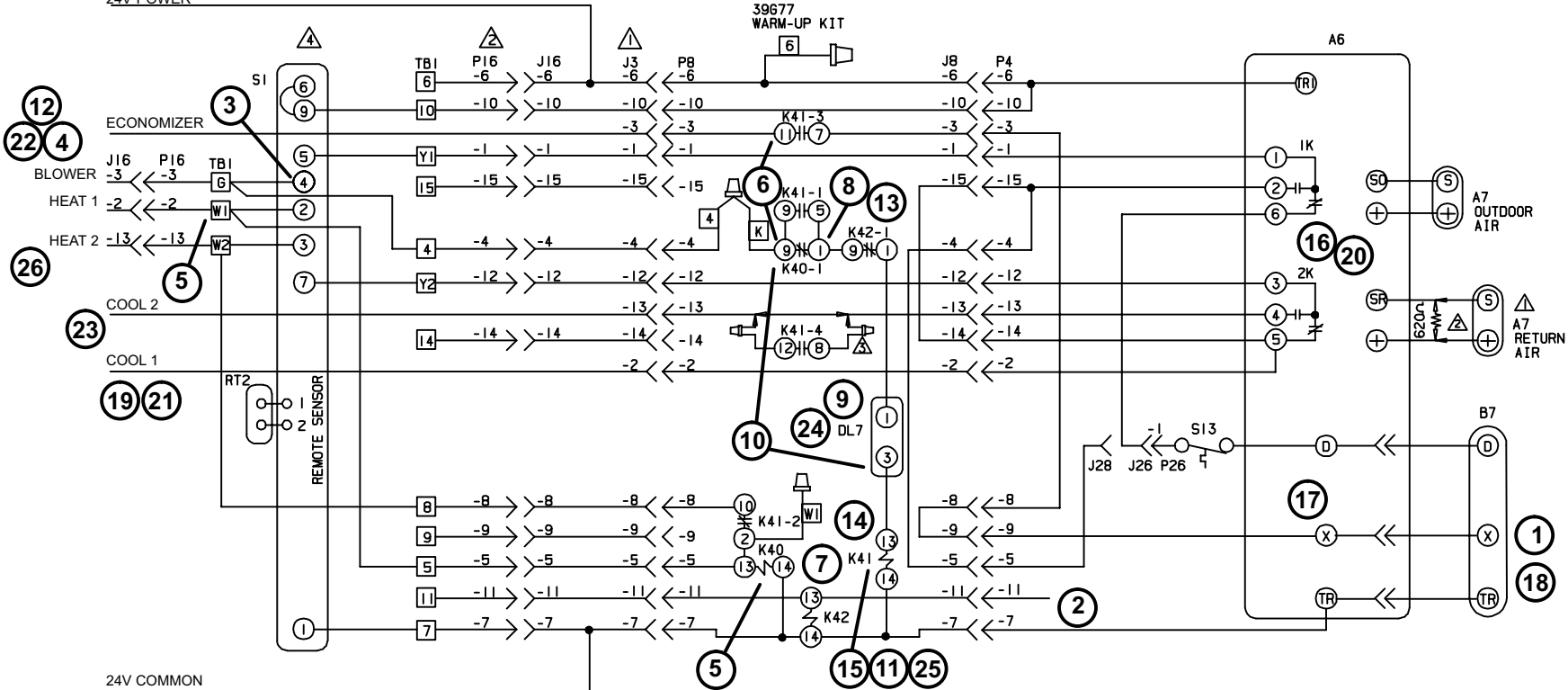

24V COMMON

KEY	COMPONENT
DL7	delay-readout
J3	jack-economizer
J8	jack-warm up kit
J16	jack-unit
K40-1	relay-warm up kit ht latch
K41-1,2,3,4	relay-warm up kit latch
K42-1	relay-warm up kit clock
P8	plug-warm up kit
P16	plug-unit
RT2	sensor-remote (optional)
S1	thermostat-room L2F-N
TB1	block-terminal (low volt)

Thermostat Footnotes

- ⚠ BLOWER OPERATION MUST BE CONTINUOUS (ON) DURING OCCUPIED PERIODS AND INTERMITTENT (AUTO) DURING UNOCCUPIED PERIODS WHEN WARM UP KIT IS USED
- ③ CHA15 SERIES ONLY
- ② P16 AND J16 ARE NOT USED ON I5 SERIES
- ⚠ J3 MAXIMUM LOAD 20VA 24VAC CLASS II

Economizer Footnotes

- ⚠ OPTIONAL-SECOND A7 INSTALLED IN RETURN AIR PROVIDES DIFFERENTIAL ENTHALPY CONTROL
- ⚠ FACTORY INSTALLED 620 OHM, 1 WATT, 5% RESISTOR. REMOVE WHEN SECOND A7 SENSOR IS INSTALLED TO PROVIDE DIFFERENTIAL ENTHALPY CONTROL

LENNOX Industries Inc. WIRING DIAGRAM 5/87

ACCESS-COMBINATION UNITS-ROOFTOP

ELECTRONIC THERMOSTAT FOR GCS, CHA, CHP15, 16 & I1 SERIES 2 COOL, 2 HEAT (FLEXSTAT) THERMOSTAT SECTION C4

Supersedes Form No. _____ New Form No. _____

KEY	DESCRIPTION
A6	control-enthalpy W7459A
A7	sensor-enthalpy
B7	motor-damper
J26	jack-enthalpy
J28	jack-W7400
K7-1	relay-W7400
K11-1,2	relay-nite setback
P4	plug-economizer
P26	plug-enthalpy
R1	sensor-supply air
TB11	strip-terminal

KEY	DESCRIPTION
A6	control-enthalpy (W7459C)
A7	sensor-enthalpy
B7	motor-damper
J26	jack-enthalpy
J28	jack-W7400
P4	plug-economizer
P26	plug-enthalpy
S13	thermostat-discharge air

LENNOX Industries Inc. WIRING DIAGRAM 4/89

ACCESS-COMBINATION UNITS-ROOFTOP

REMD16 SERIES
EMDH16 SERIES
(3 POSITION)

ECONOMIZER-SECTION D8

Supersedes Form No. _____ New Form No. _____

Litho U.S.A.

Litho U.S.A.

C6 diagram with D8 diagram Prostat with three-position economizer and warm-up

24V POWER

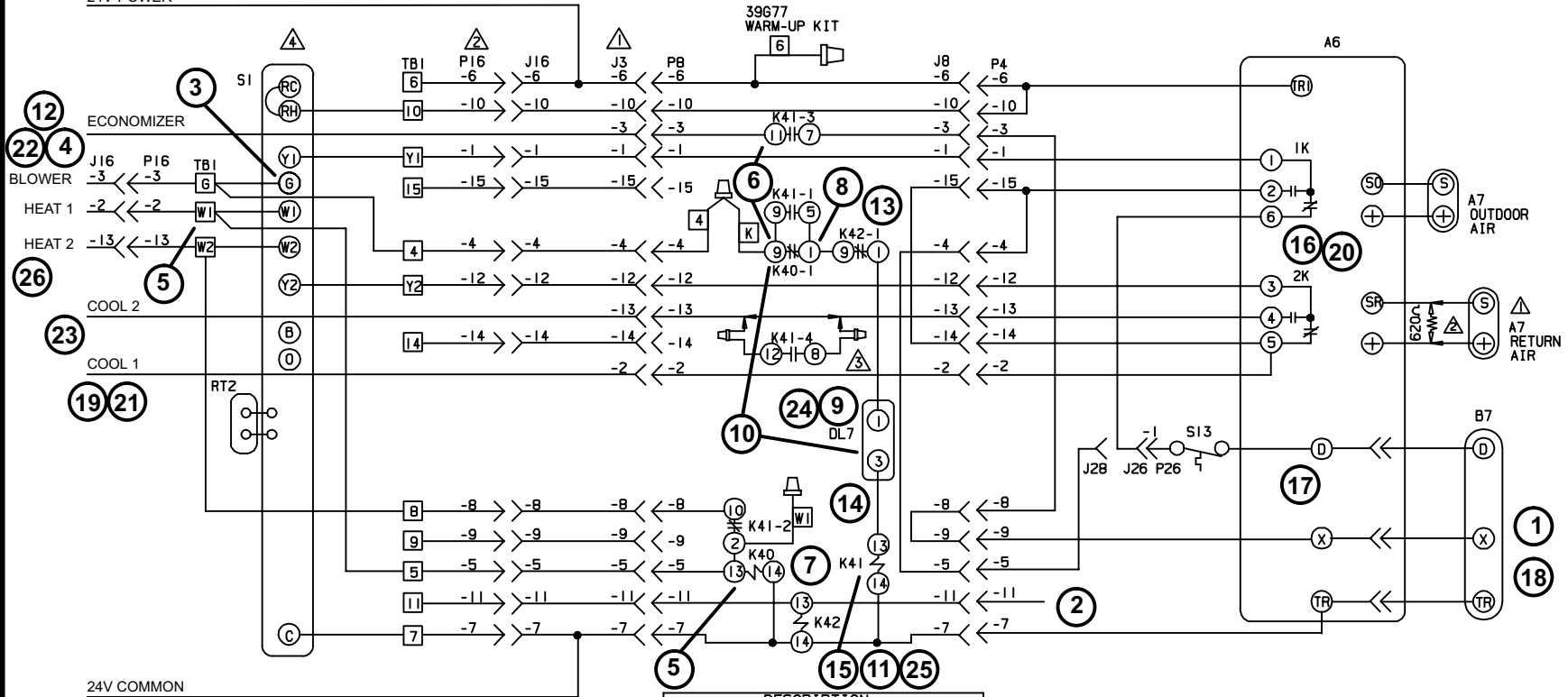

24V COMMON

Thermostat Footnotes

- ⚠ FAN SWITCH MUST BE IN ECON POSITION WHEN WARM-UP KIT IS USED
- ⚠ CHA15 SERIES ONLY
- ⚠ P16 & J16 ARE NOT USED ON I5 SERIES
- ⚠ J3 MAXIMUM LOAD 20VA 24VAC CLASS II

KEY	DESCRIPTION
A6	control-enthalpy (W7459C)
A7	sensor-enthalpy
B7	motor-damper
J26	jack-enthalpy
J28	jack-W7400
P4	plug-economizer
P26	plug-enthalpy
S13	thermostat-discharge air

Economizer Footnotes

- ⚠ OPTIONAL-SECOND A7 INSTALLED IN RETURN AIR PROVIDES DIFFERENTIAL ENTHALPY CONTROL
- ⚠ FACTORY INSTALLED 620 OHM, 1 WATT, 5% RESISTOR. REMOVE WHEN SECOND A7 SENSOR IS INSTALLED TO PROVIDE DIFFERENTIAL ENTHALPY CONTROL

LENNOX® Industries Inc. WIRING DIAGRAM 5/87

ACCESS-COMBINATION UNITS-ROOFTOP

ELECTRONIC THERMOSTAT

FOR GCS,CHA/CHP15,16 & I1 SERIES

2 COOL, 2 HEAT (PROSTAT)

THERMOSTAT SECTION C6

Supersedes Form No. _____ New Form No. _____

Litho U.S.A.

KEY	DESCRIPTION
DL7	delay-readout
J3	jack-economizer
J8	jack-warm up kit
J16	jack-unit
K40-1	relay-warm up kit-latch
K41-1,2,3,4	relay-warm up kit-latch
K42-1	relay-warm up kit-clock
PB	plug-warm up kit
P16	plug-unit
RT2	sensor-remote (optional)
S1	thermostat-room T5010
TB1	block-terminal (low volt)

LENNOX® Industries Inc. WIRING DIAGRAM 4/89

ACCESS-COMBINATION UNITS-ROOFTOP

REMD16 SERIES

EMDH16 SERIES

(3 POSITION)

ECONOMIZER-SECTION D8

Supersedes Form No. _____ New Form No. _____

Litho U.S.A.

C4 or C6 DIAGRAM WITH D8 DIAGRAM

Flexstat or Prostat with Three-position Economizer and Warm-up

4- C4 or C6 Section with D8 Section

Optional Flexstat or Prostat programmable thermostat allows GCS16 units to automatically setback setpoints for unoccupied periods as well as control setpoints more precisely than electromechanical thermostats. With economizer and warm-up kit added, both are capable of directly controlling operation of outdoor air dampers. Warm-up kit applied to the economizer holds the outdoor air dampers full closed while warming the building after being setback for an unoccupied period.

NOTE - In order to understand how these optional controls affect the operation of the GCS16, you must first understand how all GCS16 components work. Refer to the basic unit operation operation sequence.

NOTE - These thermostats have a built-in clock for controlling setback. Optional time clock CMC3-1, night thermostat and night relay kit are not needed and are not compatible.

WARNING - CONNECT ONLY RELAY KITS DESIGNED FOR THIS CONTROL SYSTEM. RELAY KITS DESIGNED FOR OTHER CONTROL SYSTEMS ARE NOT COMPATIBLE AND CONTROL DAMAGE OR FAILURE WILL RESULT. FOR EXAMPLE, NEVER CONNECT A W973 RELAY KIT TO A FLEXSTAT OR PROSTAT CONTROL SYSTEM.

WARNING - BE CAREFUL TO CONNECT RELAY KITS TO THE PROPER JACK AND PLUG IN THE GCS16 BLOWER COMPARTMENT. REFER TO WIRING DIAGRAM. IMPROPER CONNECTION WILL CAUSE CONTROL FAILURE.

Warm-up kit mounts in the control mounting area of the blower compartment (see figure 96). Some field wiring is required (refer to unit wiring diagram on opposite page). Remove and discard jumper plug P3. Warm-up kit harness plug P8 connects directly into jack J3 in blower compartment. Warm-up kit harness jack J8 connects to economizer harness plug P4. Relay K42 is not used in this application.

IMPORTANT - Flexstat model L2F has been superseded by Flexstat L2F-N. Terminal designation on the two controls are different. This sequence of operation describes models L2F-N. Refer to Table 23 for more information.

NOTE - Flexstats ONLY: If slide switch number 7 on back of model L2F-N (slide switch number 5 on back of L2F) is switched to ON position, the blower operates continuously during occupied periods and automatically cycles during unoccupied periods. If this slide switch is switched to OFF position, the blower operates normally during unoccupied periods, controlled by the ON/AUTO button on the face of the control.

Operation Sequence:

- 1- Economizer outdoor air dampers drive full closed anytime blower B3 is not operating. Dampers also close during unoccupied periods and during morning warm-up. Outdoor dampers open to minimum (mid) position during all other unit operation.
- 2- Economizer relay K11 (not shown) is not used in this application (not furnished).
- 3- Flexstat and Prostat are designed so that the fan switch in the thermostat is to be left in the ON mode at all times. This allows the blower to be controlled by terminal 4 inside the Flexstat (G in Prostat). The blower operates continuously during occupied periods and intermittently (only during demand) during unoccupied periods.
- 4- During a heating demand when the building is not occupied, the blower is activated only when a heating demand passes through relay K25 in the GCS16. During a cooling demand when the building is not occupied, the blower is activated through terminal 4 in the Flexstat (G in Prostat).

First Occupied Heating Demand of the Day (Morning Warm-Up):

- 5- Initial heating demand (Prostat terminal W1 - Flexstat terminal 4) activates the heating section of the GCS16 directly and relay K40.
- 6- Contacts K40-1 open to keep relay K41 de-energized. Contacts K41-3 remain open to keep outdoor air dampers closed during initial heating demand.

- 7- When heating demand is satisfied, unit gas valve and relay K40 are de-energized.
- 8- Contacts K40-1 close. Contacts K42-1 are closed (not used in this application).
- 9- Time delay DL7 begins a 30 second count before closing.
- 10- If a second heat demand reaches relay K40 within 30 seconds, contacts K40-1 open, time delay DL7 loses power and resets and the economizer is locked out for the second heating demand. Steps 5-10 repeat. Outdoor air dampers remain closed.
- 11- If a second heat demand does not reach relay K40 within 30 seconds, time delay DL7 closes, relay K41 energizes and contacts K41-1 and K41-3 close to lock in economizer for the day (until blower B3 stops). Outdoor air dampers open to (mid) minimum position during blower B3 operation. Outdoor air dampers close when blower B3 is not operating.

Occupied (Day) Cooling:

- 12- When thermostat switches to occupied (day) mode, blower B3 is energized in continuous mode through unit terminal strip terminal TB1-G.
- 13- Terminal TB1-G also routes power through contacts K40-1 and K42-1 to time delay DL7. Time delay DL7 begins a 30 second count before closing.
- 14- After 30 sec., time delay DL7 closes to allow relay K41 to energize.
- 15- When relay K41 energizes, contacts K41-1 close to lock in economizer until blower stops (night setback). Contacts K41-3 close to allow power to economizer.

Cooling Demand Enthalpy Low:

- 16- Enthalpy control internal relays switch to close a circuit from 1k terminal 1 to 6 and from 2K terminal 3 to 5.
- 17- Initial cooling demand (Prostat terminal Y1 - Flexstat terminal 5) is routed through enthalpy control terminals 1 and 6 and through discharge air thermostat S13 to energize enthalpy control terminal D and damper motor terminal D. 24VAC applied between damper motor terminals D and T energizes the damper motor and the outdoor air dampers open fully.
- 18- Economizer outdoor air dampers drive full open during blower B3 operation (anytime there is a cooling demand) to provide 1st stage cooling. Outdoor air dampers drive full closed anytime blower B3 is not operating.
- 19- Additional cooling demand (Prostat terminal Y2 - Flexstat terminal 7) is routed through enthalpy control terminals 1 and 2 to energize the compressor. The compressor provides all additional cooling.

Cooling Demand Enthalpy High:

- 20- Enthalpy control internal relays switch to close a circuit from 1k terminal 1 to 2 and from 2K terminal 3 to 4. Outdoor air dampers close. Dampers open to minimum position during blower operation.
- 21- Cooling demand (Prostat terminal Y1 - Flexstat terminal 5) is routed through enthalpy control terminals 1 and 2 and terminal 5 to energize the compressor. The compressor handles all cooling demand.
- 22- Blower demand (Prostat terminal G - Flexstat terminal 4) energizes blower relay K3 in the unit. Contacts K3-1 close to energize the blower and contacts K3-2 close to energize the economizer. When 24VAC is applied between enthalpy control terminals X and T, the outdoor air dampers open to mid (minimum) position. Dampers remain open when blower B3 is operating and close when B3 is not operating.
- 23- Increased cooling demand (Prostat terminal Y2 - Flexstat terminal 7) not used.

Unoccupied (Night) Operation:

- 24- Flexstat terminal 4 de-energizes. Blower B3 is de-energized and relay K41 is de-energized. Time delay DL7 opens and resets. Outdoor dampers drive full closed.
- 25- When relay K41 de-energizes, contacts K41-1 open to unlatch relay K41 circuit. Contacts K41-3 open to lock out economizer operation during unoccupied period.
- 26- Unoccupied heating demand W1 energizes relay K40 and GCS16 heat section. Contacts K40-1 open to unlatch relay K41 circuit (operates like morning warm-up).

C4 diagram with D5 diagram

Flexstat with modulating economizer and warm-up

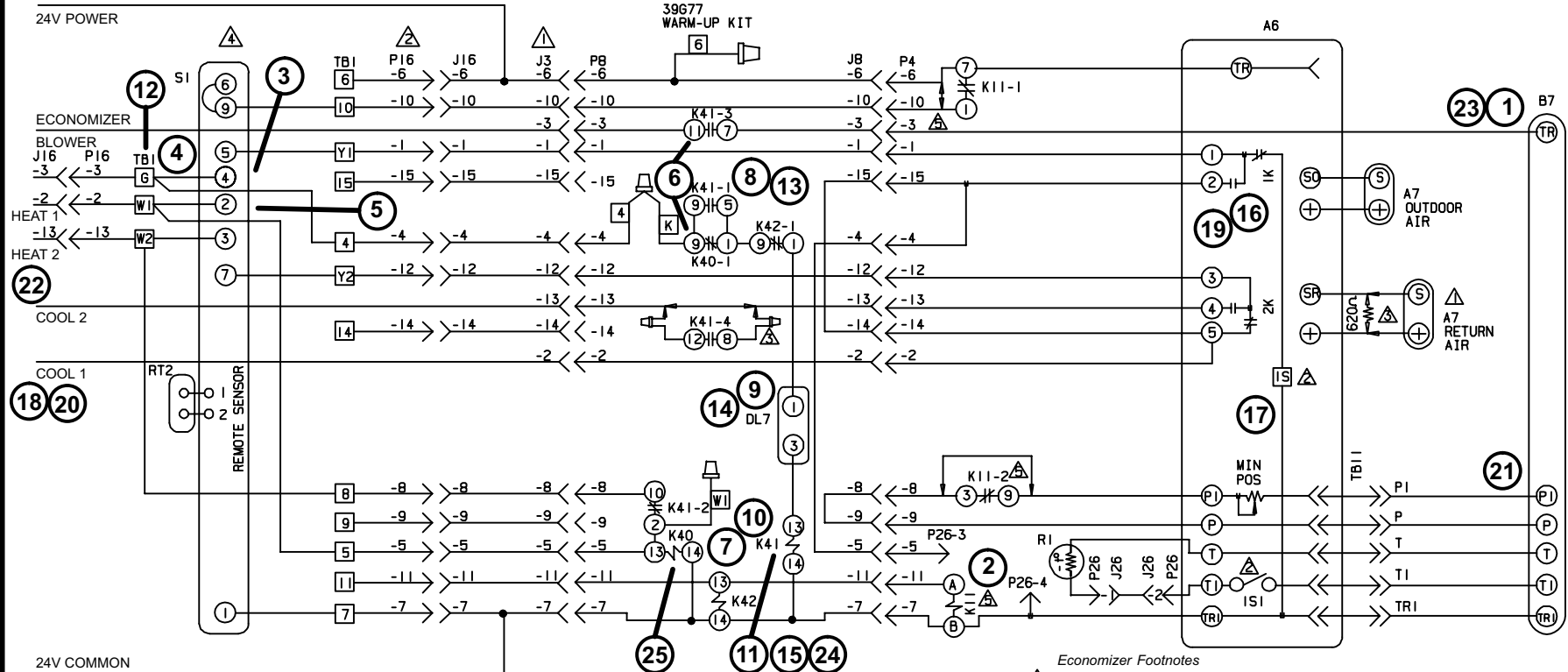

- Thermostat Footnotes**
- ⚠ BLOWER OPERATION MUST BE CONTINUOUS (ON) DURING OCCUPIED PERIODS AND INTERMITTENT (AUTO) DURING UNOCCUPIED PERIODS WHEN WARM UP KIT IS USED
 - ⚠ CHA15 SERIES ONLY
 - ⚠ P16 AND J16 ARE NOT USED ON I5 SERIES
 - ⚠ J3 MAXIMUM LOAD 20VA 24VAC CLASS II

- Economizer Footnotes**
- ⚠ OPTIONAL-SECOND A7 INSTALLED IN RETURN AIR PROVIDES DIFFERENTIAL ENTHALPY CONTROL
 - ⚠ WHEN IS RECEIVES POWER, ISI CLOSSES.
 - ⚠ FACTORY INSTALLED 620 OHM, 1 WATT, 5% RESISTOR. REMOVE WHEN SECOND A7 SENSOR IS INSTALLED TO PROVIDE DIFFERENTIAL ENTHALPY CONTROL
 - ⚠ WHEN W7400 CONTROL IS USED, REMOVE J26 JUMPER AND INSTALL J28. J28 AND K7 RELAY ARE PART OF W7400 KIT (74611)
 - ⚠ K11 NITE RELAY MAY NOT BE PART OF ECONOMIZERS ON UNITS BELOW 7.5T CAPACITY

LENNOX Industries Inc. WIRING DIAGRAM		5/87
ACCESS-COMBINATION UNITS-ROOFTOP		
ELECTRONIC THERMOSTAT		
FOR GCS, CHA, CHP15, 16 & 11 SERIES		
2 COOL, 2 HEAT (FLEXSTAT)		
THERMOSTAT SECTION C4		
Supersedes Form No.	New Form No.	

KEY	DESCRIPTION	COMPONENT
DL7	delay-readout	
J3	jack-economizer	
J8	jack-warm up kit	
J16	jack-unit	
K40-1	relay-warm up kit latch	
K41-1,2,3,4	relay-warm up kit latch	
K42-1	relay-warm up kit clock	
P8	plug-warm up kit	
P16	plug-unit	
RT2	sensor-remote (optional)	
S1	thermostat-room L2F-N	
TB1	block-terminal (low volt)	

KEY	DESCRIPTION	COMPONENT
A6	control-enthalpy W7459A	
A7	sensor-enthalpy	
B7	motor-damper	
J26	jack-enthalpy	
J28	jack-W7400	
K7-1	relay-W7400	
K11-1,2	relay-nite setback	
P4	plug-economizer	
P26	plug-enthalpy	
R1	sensor-supply air	
TB11	strip-terminal	

LENNOX Industries Inc. WIRING DIAGRAM		4/89
ACCESS-COMBINATION UNITS-ROOFTOP		
REMD16M	EMDH16M	
REMD11M	EMD17-95/135	
(MODULATING ECONOMIZER)		
ECONOMIZER-SECTION D5		
Supersedes Form No.	New Form No.	

C6 diagram with D5 diagram Prostat with modulating economizer and warm-up

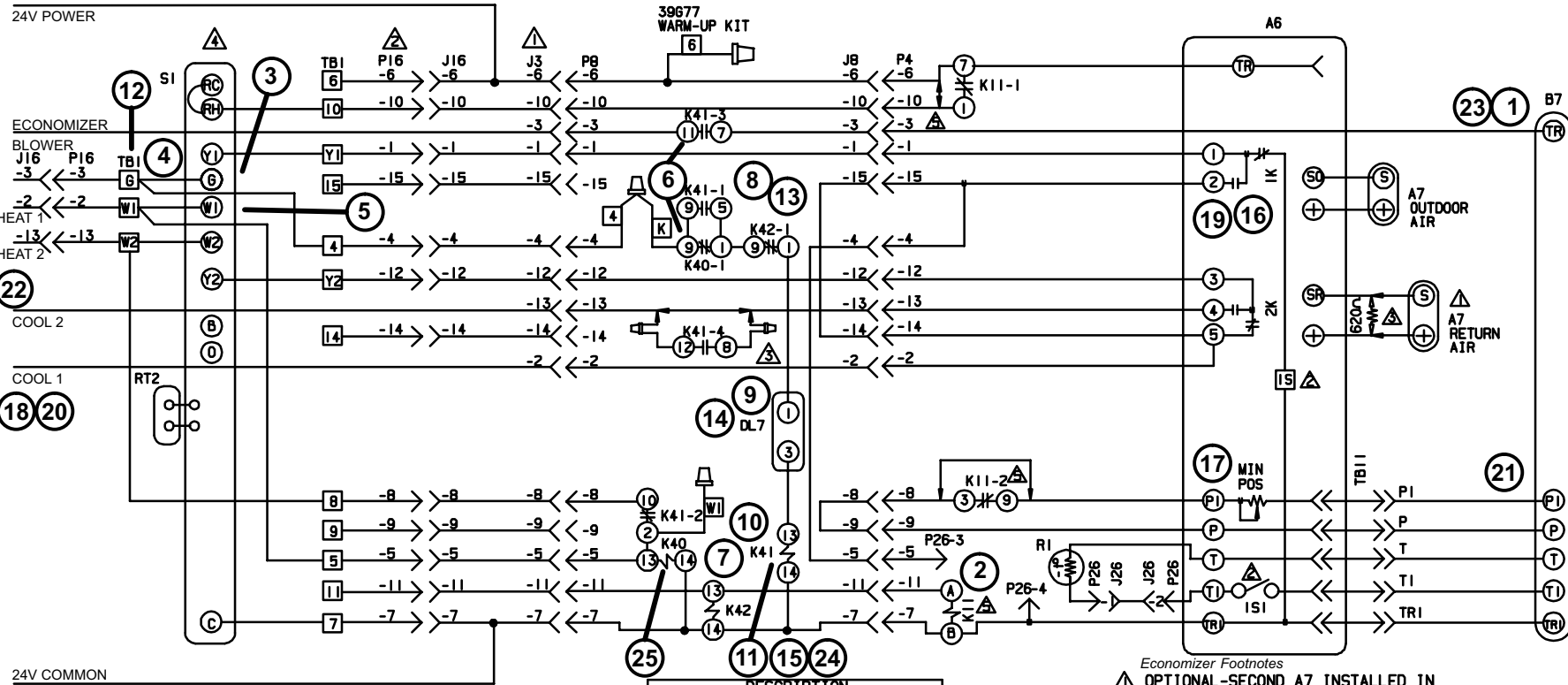

KEY	DESCRIPTION	COMPONENT
A6	control-enthalpy	W7459A
A7	sensor-enthalpy	
B7	motor-damper	
J26	jack-enthalpy	
J28	jack-W7400	
K7,-1	relay-W7400	
K11,-1,2	relay-nite setback	
P4	plug-economizer	
P26	plug-enthalpy	
RI	sensor-supply air	
TB11	strip-terminal	

KEY	DESCRIPTION	COMPONENT
DL7	delay-readout	
J3	jack-economizer	
J8	jack-warm up kit	
J16	jack-unit	
K40,-1	relay-warm up kit-latch	
K41,-1,2,3,4	relay-warm up kit-latch	
K42,-1	relay-warm up kit-clock	
P8	plug-warm up kit	
P16	plug-unit	
RT2	sensor-remote (optional)	
SI	thermostat-room	T5010
TB1	block-terminal (low volt)	

- Economizer Footnotes**
- ▲ OPTIONAL-SECOND A7 INSTALLED IN RETURN AIR PROVIDES DIFFERENTIAL ENTHALPY CONTROL
 - ▲ WHEN IS RECEIVES POWER, ISI CLOSES.
 - ▲ FACTORY INSTALLED 620 OHM, 1 WATT, 5% RESISTOR. REMOVE WHEN SECOND A7 SENSOR IS INSTALLED TO PROVIDE DIFFERENTIAL ENTHALPY CONTROL
 - ▲ WHEN W7400 CONTROL IS USED, REMOVE J26 JUMPER AND INSTALL J28. J28 AND K7 RELAY ARE PART OF W7400 KIT (74G11)
 - ▲ K11 NITE RELAY MAY NOT BE PART OF ECONOMIZERS ON UNITS BELOW 7.5T CAPACITY

- Thermostat Footnotes**
- ▲ FAN SWITCH MUST BE IN ECON POSITION WHEN WARM-UP KIT IS USED
 - ▲ CHA15 SERIES ONLY
 - ▲ P16 & J16 ARE NOT USED ON 15 SERIES
 - ▲ J3 MAXIMUM LOAD 20VA 24VAC CLASS II

LENNOX Industries Inc. WIRING DIAGRAM 5/87

ACCESS-COMBINATION UNITS-ROOFTOP

ELECTRONIC THERMOSTAT FOR GCS, CHA/CHP15, 16 & 11 SERIES 2 COOL, 2 HEAT (PROSTAT)

THERMOSTAT SECTION C6

Supersedes Form No. _____ New Form No. _____

LENNOX Industries Inc. WIRING DIAGRAM 4/89

ACCESS-COMBINATION UNITS-ROOFTOP

REMD16M EMDH16M
 REMDI1M EMDI7-95/135
 (MODULATING ECONOMIZER)

ECONOMIZER-SECTION D5

Supersedes Form No. _____ New Form No. _____

C4 or C6 DIAGRAM WITH D5 DIAGRAM FLEXSTAT or PROSTAT WITH MODULATING ECONOMIZER AND WARM-UP

5- C4 or C6 Section with D5 Section

Optional Flexstat or Prostat programmable thermostats allow GCS16 units to automatically setback setpoints for unoccupied periods as well as control setpoints more precisely than electromechanical thermostats. With modulating economizer and warm-up kit added, Flexstat and Prostat are capable of directly controlling outdoor air damper operation. The warm-up kit holds outdoor air dampers full closed while warming the building after night setback.

NOTE - In order to understand how these optional controls affect the operation of the GCS16, you must first understand how all GCS16 components work. Refer to the operation sequence for basic unit operation.

NOTE - These thermostats have a built-in clock for controlling setback. Optional time clock CMC3-1, night thermostat and night relay kit are not needed and are not compatible.

WARNING - CONNECT ONLY RELAY KITS DESIGNED FOR THIS CONTROL SYSTEM. RELAY KITS DESIGNED FOR OTHER CONTROL SYSTEMS ARE NOT COMPATIBLE AND CONTROL DAMAGE OR FAILURE WILL RESULT. FOR EXAMPLE, NEVER CONNECT A W973 RELAY KIT TO A FLEXSTAT OR PROSTAT CONTROL SYSTEM.

WARNING - BE CAREFUL TO CONNECT RELAY KITS TO THE PROPER JACK AND PLUG IN THE GCS16 BLOWER COMPARTMENT. REFER TO WIRING DIAGRAM. IMPROPER CONNECTION WILL CAUSE CONTROL FAILURE.

The warm-up kit mounts in the control mounting area of the blower compartment (see figure 96). Some field wiring of the warm-up kit is required (refer to unit wiring diagrams on opposite page). GCS16 unit jumper plug P3 is removed and discarded. Warm-up kit harness plug P8 connects directly into jack J3 in the blower compartment. Warm-up kit harness jack J8 connects to economizer harness plug P4. Relay K42 is not used in this application.

IMPORTANT - Flexstat model L2F has been superseded by Flexstat L2F-N. Terminal designation on the two controls are different. This sequence of operation describes models L2F-N. Refer to Table 23 for more information.

NOTE - Flexstats ONLY: If slide switch number 7 on back of model L2F-N (slide switch number 5 on back of L2F) is switched to ON position, the blower operates continuously during occupied periods and automatically cycles during unoccupied periods. If this slide switch is switched to OFF position, the blower operates normally during unoccupied periods, controlled by the ON/AUTO button on the face of the control.

Operation Sequence:

- 1- Economizer outdoor air dampers drive full closed anytime blower B3 is not operating. Dampers also close during unoccupied periods and during morning warm-up. Dampers open to minimum position during all other unit operation.
- 2- Economizer relay K11 is not used in this application (not furnished).
- 3- The Flexstat and Prostat are designed so the thermostat fan switch is to be left in the ON mode at all times. This allows the blower to be controlled by terminal 4 inside the Flexstat (G in Prostat). The blower operates continuously during occupied periods and intermittently (only during demand) during unoccupied periods.
- 4- During heating demand when building is unoccupied, blower is activated only when heating demand passes through relay K25 in GCS16. During cooling demand when building is unoccupied, blower is activated through terminal 4 in Flexstat (G in Prostat).

First Occupied Heating Demand of the Day (Morning Warm-Up):

- 5- Initial heating demand (Prostat terminal W1 - Flexstat terminal 2) activates the heating section of the GCS16 directly and relay K40.
- 6- Contacts K40-1 open to keep relay K41 de-energized. Contacts K41-3 remain open to keep outdoor air dampers closed during initial heating demand.
- 7- When heating demand is satisfied, unit gas valve and relay K40 are de-energized.

- 8- Contacts K40-1 close. Contacts K42-1 are already closed (not used in this application).

- 9- Time delay DL7 begins a 30 second count before closing.

- 10- If a second heat demand reaches relay K40 within 30 seconds, contacts K40-1 open, time delay DL7 loses power and resets and the economizer is locked out for the 2nd heating demand. Steps 5-10 repeat. Outdoor air dampers remain closed.

- 11- If a second heat demand does not reach relay K40 within 30 seconds, time delay DL7 closes, relay K41 energizes and contacts K41-1 and K41-3 close to lock in the economizer for the day (until blower B3 stops). Outdoor air dampers open to minimum position allowed by minimum positioner during blower B3 operation. Outdoor air dampers close when blower B3 is not operating.

Occupied (Day) Cooling:

- 12- When thermostat switches to occupied (day) mode, blower B3 is energized in continuous mode through unit terminal strip terminal TB1-G.

- 13- Terminal TB1-G also routes power through contacts K40-1 and K42-1 to time delay DL7. Time delay DL7 begins a 30 second count before closing.

- 14- After 30 sec., time delay DL7 closes to allow relay K41 to energize.

- 15- When relay K41 energizes, contacts K41-1 close to lock in economizer until blower stops (night setback). Contacts K41-3 close to allow power to the economizer.

Cooling Demand Enthalpy Low:

- 16- Enthalpy control internal relays switch to close a circuit from 1k terminal 1 to 6 and from 2K terminal 3 to 5.

- 17- Cooling demand (Y1 in Prostat - 4 in Flexstat) is routed through enthalpy control terminal 1 to energize internal relay 1S. Contacts 1S1 close to energize damper motor. Outdoor air dampers open to provide first stage cooling.

- 18- Increased cooling demand (Y2 in Prostat - 7 in Flexstat) is routed through enthalpy control terminals 3 and 5 to energize the compressor. The compressor handles all additional cooling demand. Outdoor air dampers remain open.

Cooling Demand Enthalpy High:

- 19- Enthalpy control internal relays switch to close a circuit from 1k terminal 1 to 2 and from 2K terminal 3 to 4. Outdoor air dampers close. Dampers open to minimum position during blower operation.

- 20- Cooling demand (Prostat terminal Y1 - Flexstat terminal 5) is routed through enthalpy control terminals 1 and 2 and terminal 5 to energize the compressor. The compressor handles all cooling demand.

- 21- Blower demand (from Flexstat terminal 4 - Prostat terminal G) energizes blower relay K3 in unit. Contacts K3-1 close to energize blower and contacts K3-2 close to energize damper motor terminal TR. When 24VAC is applied between damper motor terminals TR and TR1, outdoor dampers open to minimum position. Dampers remain open when blower B3 is operating and close when B3 is not operating.

- 22- Increased cooling demand (Prostat terminal Y2 - Flexstat terminal 7) is not used in this application.

Unoccupied (Night) Operation:

- 23- Flexstat terminal 4 (G in Prostat) de-energizes. Blower B3 is de-energized and relay K41 is de-energized. Time delay DL7 opens and resets. Outdoor dampers drive full closed.

- 24- When relay K41 de-energizes, Contacts K41-1 open to unlatch relay K41 circuit. Contacts K41-3 open to lock out economizer operation during unoccupied period.

- 25- Unoccupied heating demand (Prostat terminal W1 - Flexstat terminal 2) energizes relay K40 and GCS16 heat section. Contacts K40-1 open to unlatch relay K41 circuit (operates like morning warm-up).

C12 diagram T7300 thermostat

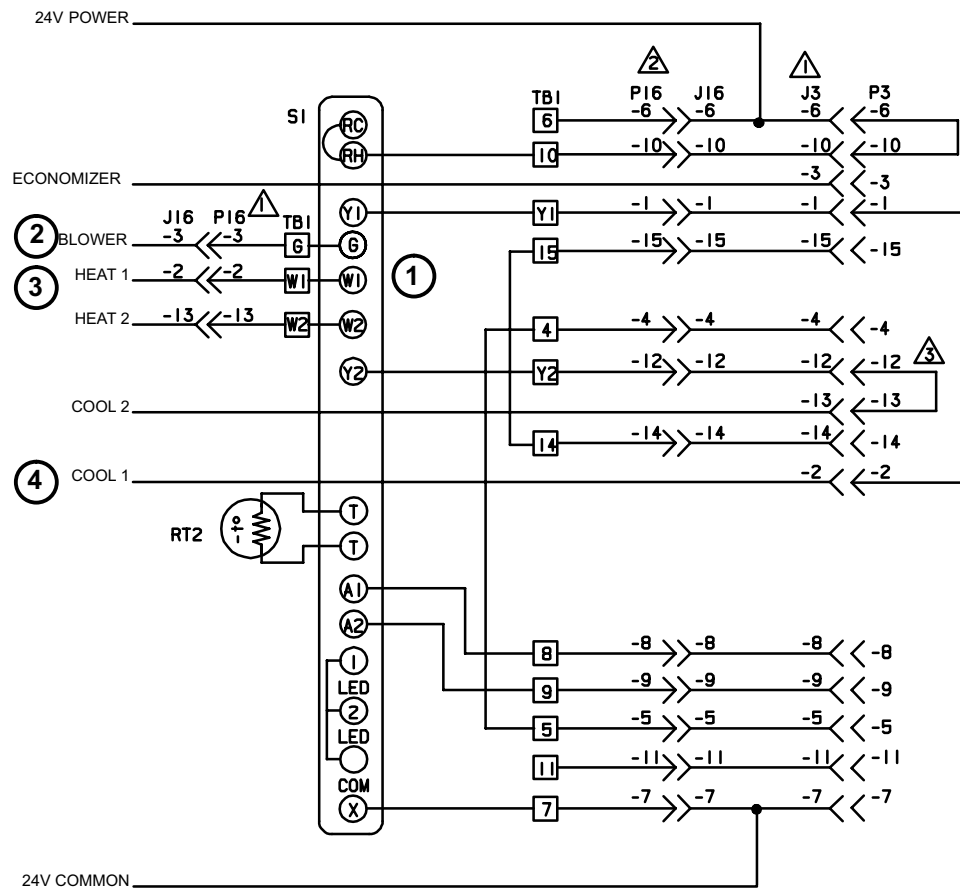

KEY	DESCRIPTION
J3	jack-economizer
J16	jack-unit
P3	plug-jumper
P16	plug-unit
RT2	sensor-thermostat
S1	thermostat-room T7300
TBI	block-terminal(low volt)

- ⚠ P3-12 TO P3-13 JUMPER IS NOT USED ON LATER CHA15 SERIES
- ⚠ P16 AND J16 ARE NOT USED ON 15 SERIES
- ⚠ J3 MAXIMUM LOAD 20VA 24VAC CLASS II

LENNOX Industries Inc. WIRING DIAGRAM		5/8
ACCESS-COMBINATION UNITS-ROOFTOP		
ELECTRONIC THERMOSTAT		
11, 15 & 16 SERIES		
2 HEAT, 2 COOL		
THERMOSTAT SECTION-C12		
Supersedes Form No.	New Form No.	

Litho U.S.

C12 DIAGRAM

Honeywell T7300 Thermostat without Economizer

6-C12 Section

The Honeywell T7300 programmable thermostat allows GCS16 units without economizer to automatically setback or setup setpoints for unoccupied periods as well as control setpoints more precisely than electromechanical thermostats.

NOTE - In order to understand how these optional controls affect the operation of the GCS16, you must first understand how all GCS16 components work. Refer to the operation sequence for basic unit operation.

NOTE - These thermostats have a built-in clock for controlling setback. Optional time clock CMC3-1, night thermostat and night relay kit are not needed and are not compatible.

Operation Sequence:

- 1- The GCS16 with T7300 is designed so that the fan switch in the thermostat should be left in the ON mode at all times. This allows the blower to be controlled by terminal G in the thermostat. The blower operates continuously during occupied periods and intermittently during unoccupied periods.
- 2- During a heating demand when the building is not occupied, the blower is activated only when a heating demand passes through relay K25 in the GCS16. During a cooling demand when the building is not occupied, the blower is activated through terminal G in the thermostat.
- 3- Heating demand W1 directly energizes the heat section of the GCS16.
- 4- Cooling demand Y1 is routed through plug P3 to activate the cooling circuit of the GCS16 directly.

C12 diagram with D8 diagram T7300 with three-position economizer

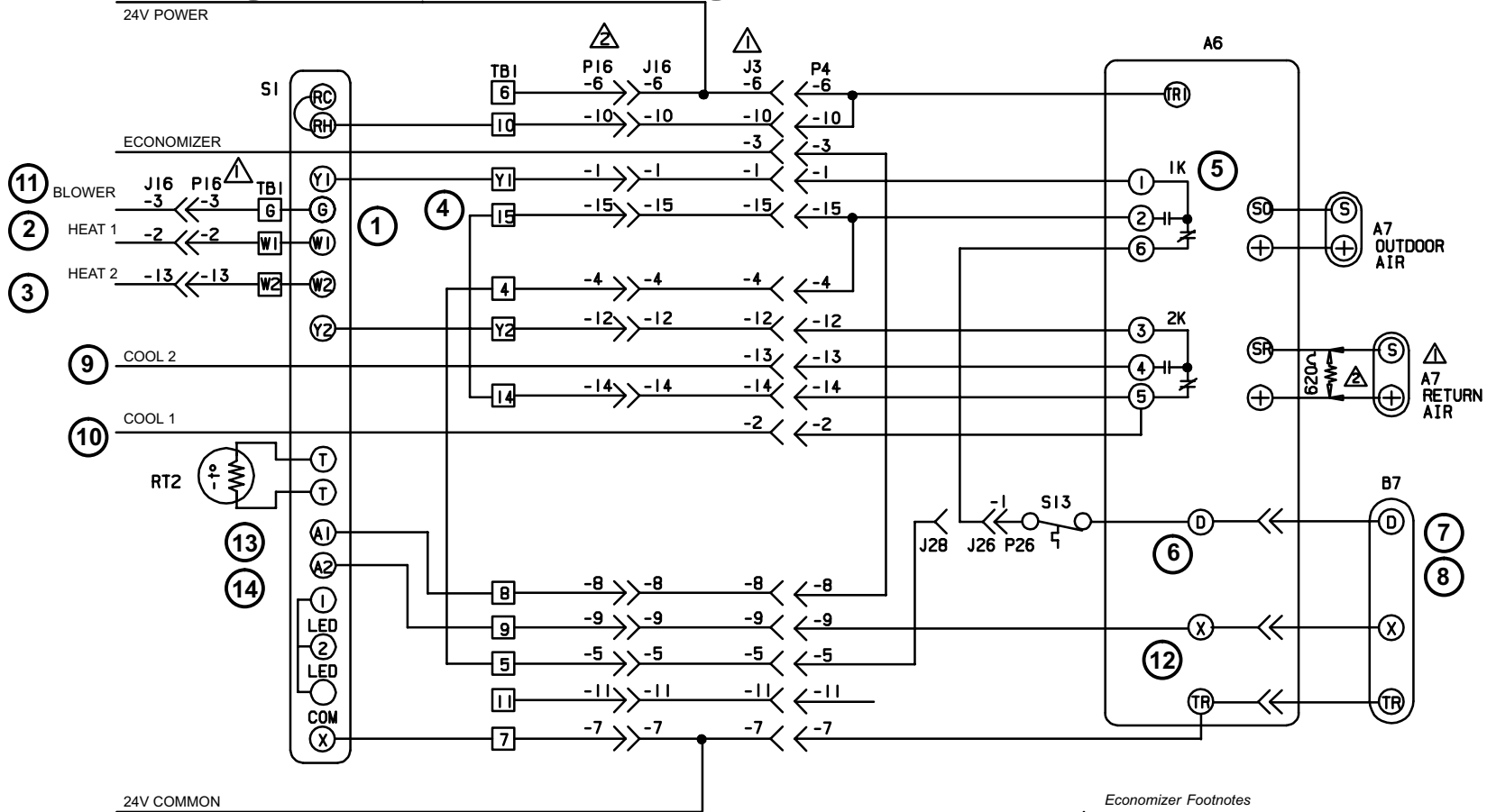

Thermostat Footnotes

- ⚠ P3-12 TO P3-13 JUMPER IS NOT USED ON LATER CHA15 SERIES
- ⚠ P16 AND J16 ARE NOT USED ON 15 SERIES
- ⚠ J3 MAXIMUM LOAD 20VA 24VAC CLASS II

Economizer Footnotes

- ⚠ OPTIONAL-SECOND A7 INSTALLED IN RETURN AIR PROVIDES DIFFERENTIAL ENTHALPY CONTROL
- ⚠ FACTORY INSTALLED 620 OHM, 1 WATT, 5% RESISTOR. REMOVE WHEN SECOND A7 SENSOR IS INSTALLED TO PROVIDE DIFFERENTIAL ENTHALPY CONTROL

LENNOX Industries Inc. WIRING DIAGRAM 5/8	
ACCESS-COMBINATION UNITS-ROOFTOP	
ELECTRONIC THERMOSTAT 11, 15 & 16 SERIES 2 HEAT, 2 COOL	
THERMOSTAT SECTION-C12	
Supersedes Form No.	New Form No.

KEY	DESCRIPTION	COMPONENT
A6	control-enthalpy	(W7459C)
A7	sensor-enthalpy	
B7	motor-damper	
J26	jack-enthalpy	
J28	jack-W7400	
P4	plug-economizer	
P26	plug-enthalpy	
S13	thermostat-discharge air	

KEY	DESCRIPTION	COMPONENT
J3	jack-economizer	
J16	jack-unit	
P3	plug-jumper	
P16	plug-unit	
RT2	sensor-thermostat	
S1	thermostat-room T7300	
TBI	block-terminal (low volt)	

LENNOX Industries Inc. WIRING DIAGRAM 4/89	
ACCESS-COMBINATION UNITS-ROOFTOP	
REMD16 SERIES EMDH16 SERIES (3 POSITION)	
ECONOMIZER-SECTION D8	
Supersedes Form No.	New Form No.

C12 DIAGRAM WITH D8 DIAGRAM

Honeywell T7300 Thermostat with Three-Position Economizer

7-C12 Section with D8 Section

The Honeywell T7300 programmable thermostat allows GCS16 units without economizer to automatically setback or setup setpoints for unoccupied periods as well as control setpoints more precisely than electromechanical thermostats. With the economizer added, the T7300 is capable of directly controlling the economizer and can directly control morning warm-up.

NOTE - In order to understand how these optional controls affect the operation of the GCS16, you must first understand how all GCS16 components work. Refer to the operation sequence for basic unit operation.

NOTE - These thermostats have a built-in clock for controlling setback. Optional time clock CMC3-1, night thermostat and night relay kit are not needed and are not compatible.

Operation Sequence:

- 1- The GCS16 with T7300 is designed so that the fan switch in the thermostat should be left in the ON mode at all times. This allows the blower to be controlled by terminal G in the thermostat. The blower operates continuously during occupied periods and intermittently during unoccupied periods.
- 2- During a heating demand when the building is not occupied, the blower is activated only when a heating demand passes through relay K25 in the GCS16. During a cooling demand when the building is not occupied, the blower is activated through terminal G in the thermostat.

Heating:

- 3- Heating demand W1 from the T7300 energizes the heat section of the GCS16 directly. When relay K13 is energized to start the combustion air blower, contacts K13-2 close. When contacts K13-2 close, 24VAC is passed to T7300 terminal A1. When A1 is energized, A2 is energized and 24VAC is passed to terminal X on the enthalpy control and damper motor. Outdoor dampers open to mid (minimum) position.

I. Enthalpy Control in Low Position (outside air can be used for cooling).

1st stage cool (all models):

- 4- Initial cooling demand Y1 is sent to enthalpy control A6 terminal 1.

- 5- Enthalpy control A6 has determined that outside air can be used for cooling and has switched 1K and 2K internally.

- 6- Cooling demand is routed through enthalpy control terminal 6 and through discharge air thermostat S13 to enthalpy control terminal D and damper motor terminal D.

- 7- When 24VAC is applied across terminals D and T of damper motor, the damper motor energizes and outdoor dampers open fully. First stage cooling is provided by outdoor air.

2nd stage cool (all models):

- 8- Economizer outdoor air dampers remain open.

- 9- Additional cooling demand is routed from thermostat Y2 through enthalpy control terminals 3 and 5 to energize the compressor. The compressor provides all additional cooling demand.

II. Enthalpy Control in High Position (outside air cannot be used for cooling).

- 10- Cooling demand is sent from thermostat terminal Y1 through enthalpy control terminals 1 and 2 and through enthalpy control terminal 5 to energize the compressor. The compressor handles all cooling demand.

- 11- Simultaneously, blower demand energizes relay K3 in the unit. Contacts K3-2 close to energize terminal A1 on the T7300.

- 12- T7300 has determined that minimum position is appropriate (day mode) and terminal A2 is energized. A2 energizes terminal X on enthalpy control A6 and damper motor B7. When 24VAC is applied across terminals X and T of damper motor, the damper motor energizes and outdoor dampers open to mid (minimum) position.

Night Setback (optional field installed)

- 13- Night setback and morning warm-up are controlled directly by the T7300. During night setback, the T7300 changes to unoccupied setpoints. Operation sequence does not change. Outdoor dampers are held closed by T7300 terminal A2.

- 14- During morning warm-up (first heat demand of the day - after night setback) T7300 terminal A2 remains de-energized and the outdoor dampers remain closed.

C12 diagram with D5 diagram T7300 with modulating economizer

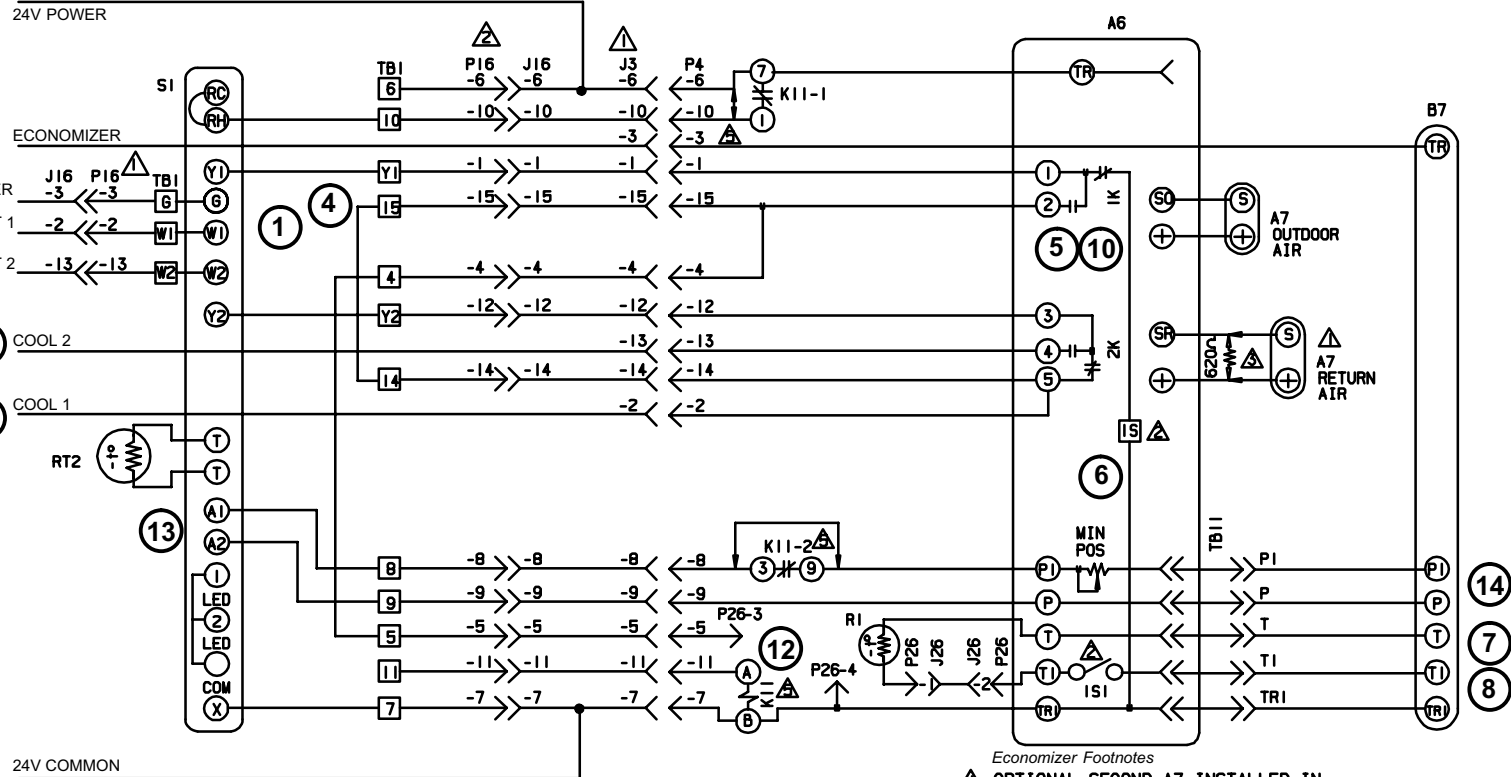

- Thermostat Footnotes**
- ⚠ P3-12 TO P3-13 JUMPER IS NOT USED ON LATER CHA15 SERIES
 - ⚠ P16 AND J16 ARE NOT USED ON 15 SERIES
 - ⚠ J3 MAXIMUM LOAD 20VA 24VAC CLASS II

- Economizer Footnotes**
- ⚠ OPTIONAL-SECOND A7 INSTALLED IN RETURN AIR PROVIDES DIFFERENTIAL ENTHALPY CONTROL
 - ⚠ WHEN IS RECEIVES POWER, ISI CLOSES.
 - ⚠ FACTORY INSTALLED 620 OHM, 1 WATT, 5% RESISTOR. REMOVE WHEN SECOND A7 SENSOR IS INSTALLED TO PROVIDE DIFFERENTIAL ENTHALPY CONTROL
 - ⚠ WHEN W7400 CONTROL IS USED, REMOVE J26 JUMPER AND INSTALL J28. J28 AND K7 RELAY ARE PART OF W7400 KIT (74611)
 - ⚠ K11 NITE RELAY MAY NOT BE PART OF ECONOMIZERS ON UNITS BELOW 7.5T CAPACITY

LENNOX Industries Inc. WIRING DIAGRAM 5/8

ACCESS-COMBINATION UNITS-ROOFTOP

ELECTRONIC THERMOSTAT
11, 15 & 16 SERIES
2 HEAT, 2 COOL

THERMOSTAT SECTION-C12

Supersedes Form No. _____ New Form No. _____

KEY	DESCRIPTION
	COMPONENT
A6	control-enthalpy W7459A
A7	sensor-enthalpy
B7	motor-damper
J26	jack-enthalpy
J28	jack-W7400
K7,-1	relay-W7400
K11,-1,2	relay-nite setback
P4	plug-economizer
P26	plug-enthalpy
R1	sensor-supply air
TB11	strip-terminal

KEY	DESCRIPTION
	COMPONENT
J3	jack-economizer
J16	jack-unit
P3	plug-jumper
P16	plug-unit
RT2	sensor-thermostat
S1	thermostat-room T7300
TB1	block-terminal (low volt)

LENNOX Industries Inc. WIRING DIAGRAM 4/89

ACCESS-COMBINATION UNITS-ROOFTOP

REMD16M EMDH16M
REMD11M EMD17-95/135
(MODULATING ECONOMIZER)

ECONOMIZER-SECTION D5

Supersedes Form No. _____ New Form No. _____

C12 DIAGRAM WITH D5 DIAGRAM

Honeywell T7300 Thermostat with Modulating Economizer

8-C12 Section with D5 Section

The Honeywell T7300 programmable thermostat allows GCS16 units without economizer to automatically setback or setup setpoints for unoccupied periods as well as control setpoints more precisely than electromechanical thermostats. With the modulating economizer added, the T7300 is capable of directly modulating the economizers and can directly control morning warm-up.

NOTE - In order to understand how these optional controls affect the operation of the GCS16, you must first understand how all GCS16 components work. Refer to the operation sequence for basic unit operation.

NOTE - These thermostats have a built-in clock for controlling setback. Optional time clock CMC3-1, night thermostat and night relay kit are not needed and are not compatible.

Operation Sequence:

- 1- The GCS16 with T7300 is designed so that the fan switch in the thermostat should be left in the ON mode at all times. This allows the blower to be controlled by terminal G in the thermostat. The blower operates continuously during occupied periods and intermittently during unoccupied periods.
- 2- During a heating demand when the building is not occupied, the blower is activated only when a heating demand passes through relay K25 in the GCS16. During a cooling demand when the building is not occupied, the blower is activated through terminal G in the thermostat.

Heating:

- 3- Heating demand W1 from the T7300 energizes the heat section of the GCS16 directly. When relay K13 is energized to start the combustion air blower, contacts K13-2 close. When contacts K13-2 close, 24VAC is passed to damper motor terminal TR. Outdoor dampers open to minimum position.

I. Enthalpy Control in Low Position (outside air can be used for cooling).

First stage cool (all models):

- 4- Initial cooling demand Y1 is sent to enthalpy control A6 terminal 1.

- 5- Enthalpy control A6 has determined that outside air can be used for cooling and has switched internal 1K and 2K internally.

- 6- Cooling demand is routed through enthalpy control to energize internal relay 1S. Internal contacts 1S1 close to complete a circuit through damper motor terminals T and T1.

- 7- When a voltage is applied across terminals T and T1 of damper motor, the damper motor energizes and outdoor dampers open. Supply air sensor R1 varies the voltage across T and T1 and the outdoor air dampers adjust accordingly. First stage cooling is provided by outdoor air. Dampers are modulated by T7300 terminals A1 and A2 (RT2) and supply air sensor R1.

Second stage cool (all models):

- 8- Economizer outdoor air dampers remain open.

- 9- Additional cooling demand is routed from thermostat Y2 through enthalpy control terminals 3 and 5 to energize the compressor. The compressor provides all additional cooling.

II. Enthalpy Control in High Position (outside air cannot be used for cooling).

Cooling:

- 10- Enthalpy control internal relays 1K and 2K switch. Internal relay 1S is de-energized and 1S1 opens. Outdoor air dampers close to minimum position.

- 11- Cooling demand is sent from thermostat terminal Y1 through enthalpy control terminals 1 and 2 and through enthalpy control terminal 5 to energize the compressor. The compressor handles all cooling.

Night Setback (optional field installed):

- 12- Night relay K11 (not furnished) is not used in this application and K11 contacts K11-1 and K11-2 (if installed) should remain closed at all times.

- 13- Night setback and morning warm-up are controlled directly by the T7300. During night setback, the T7300 changes to unoccupied setpoints. Operation sequence does not change. Outdoor dampers are held closed by T7300 terminal A2.

- 14- During morning warm-up (first heat demand of the day - after night setback) T7300 terminal A2 remains de-energized and the outdoor dampers remain closed.

C7-3 diagram with D8 diagram W7400 Control three-position economizer

24V POWER

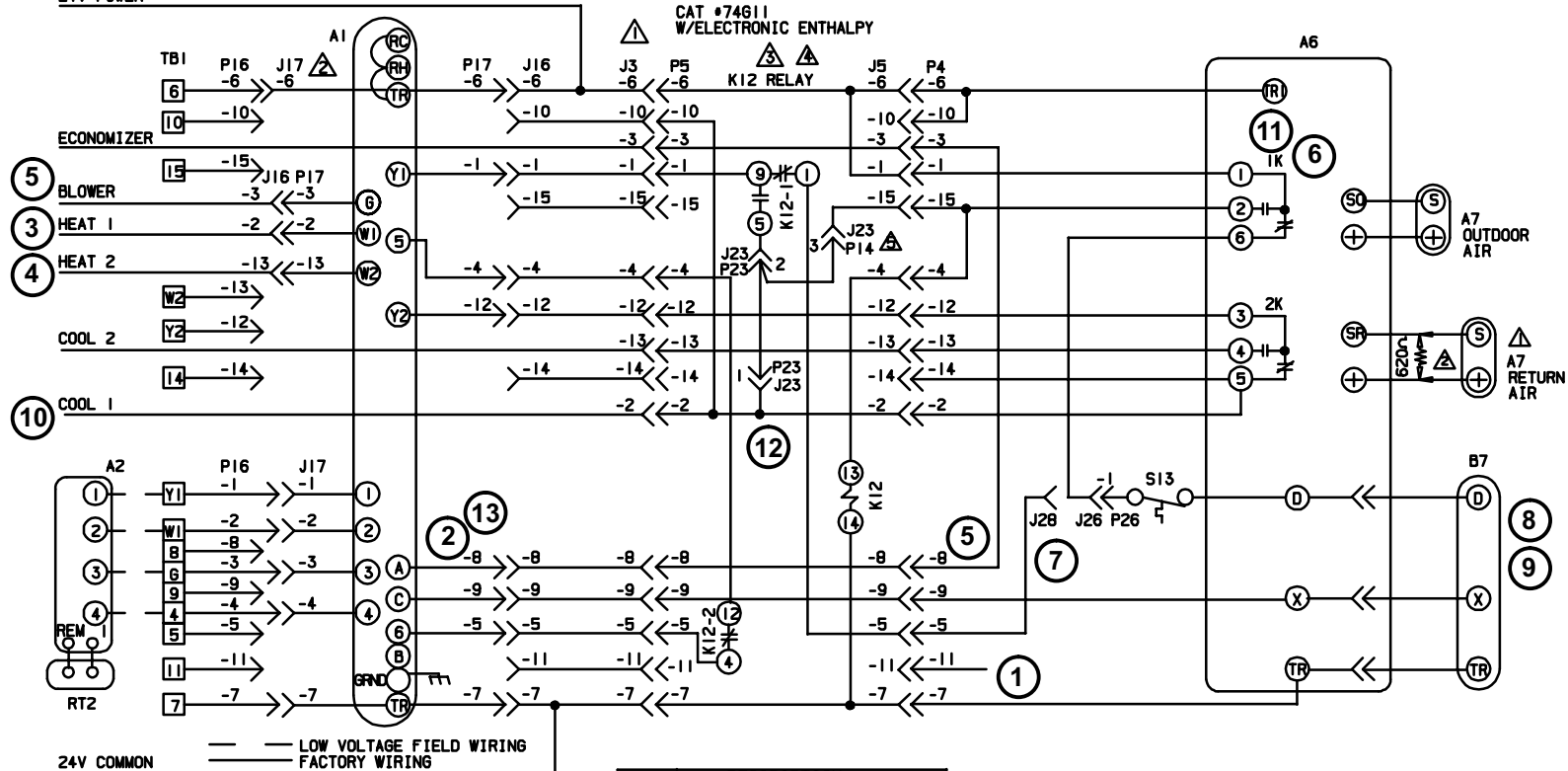

- Thermostat Footnotes*
- ▲ FOR USE WITH ECONOMIZER SECTION OR LVAV
 - ▲ USE RELAY KIT WITH ECONOMIZER. WITHOUT ECONOMIZER USE P3
 - ▲ P23 IS USED FOR NORMAL SINGLE ZONE APPLICATIONS. P14 IS USED FOR LVAV APPLICATIONS ONLY
 - ▲ TO INSTALL W7400 MODULE. DISCONNECT P16 FROM J16 (IN UNIT CONTROL BOX) CONNECT J17 TO P16, AND P17 TO P16
 - ▲ J3 MAXIMUM LOAD 20VA 24VAC CLASS II

- Economizer Footnotes*
- ▲ OPTIONAL-SECOND A7 INSTALLED IN RETURN AIR PROVIDES DIFFERENTIAL ENTHALPY CONTROL
 - ▲ FACTORY INSTALLED 620 OHM, 1 WATT, 5% RESISTOR. REMOVE WHEN SECOND A7 SENSOR IS INSTALLED TO PROVIDE DIFFERENTIAL ENTHALPY CONTROL

DESCRIPTION	
KEY	COMPONENT
A6	control-enthalpy W7459A
A7	sensor-enthalpy
B7	motor-damper
J26	jack-enthalpy
J28	jack-W7400
K7,-1	relay-W7400
K11,-1,2	relay-nite setback
P4	plug-economizer
P26	plug-enthalpy
RI	sensor-supply air
TB11	strip-terminal

DESCRIPTION	
KEY	COMPONENT
A6	control-enthalpy (W7459C)
A7	sensor-enthalpy
B7	motor-damper
J26	jack-enthalpy
J28	jack-W7400
P4	plug-economizer
P26	plug-enthalpy
S13	thermostat-discharge air

LENNOX Industries Inc.	WIRING DIAGRAM	9/88
ACCESS-COMBINATION UNITS-ROOFTOP		
THERMOSTAT FOR		
GCS, CHA, CHP16 SERIES UNITS		
WITH W7400 CONTROL OPTION		
THERMOSTAT SECTION-C7-3		
Supersedes Form No.	New Form No.	

LENNOX Industries Inc.	WIRING DIAGRAM	4/89
ACCESS-COMBINATION UNITS-ROOFTOP		
REMD16 SERIES		
EMDH16 SERIES		
(3 POSITION)		
ECONOMIZER-SECTION D8		
Supersedes Form No.	New Form No.	

C7-3 DIAGRAM WITH D8 DIAGRAM

Honeywell W7400 Control System and T7400 Thermostat with Three-Position Economizer

D-ELECTRONIC CONTROL SYSTEMS

1-C7-3 Section with D8 Section

The Honeywell W7400 control / T7400 thermostat system, when applied to a GCS16 allows fully programmable operation of the unit during occupied or unoccupied periods. Morning warm-up capabilities are built-in to the control system. An external warm-up kit is not needed and should not be used. This diagram shows a three-position economizer connected to a W7400 control system.

An economizer may be added to the system to allow outside air for cooling. A relay (K12 - figure 95) must be added to interface the control to the economizer. In this sequence of operation, the W7400 relay kit is specially wired to interface the control to an economizer using a solid state enthalpy control. Relay kits for early electromechanical enthalpy controls (as used in D2 wiring diagrams) cannot be used or control damage will result. All economizers for 2-5 ton GCS16 units are equipped with electronic enthalpy controls and the updated relay kit must be used. Unit jackplug J3 must be installed in place of relay kit for basic unit operation without economizer (since it is improbable that a W7400 system be used without economizer, this wiring diagram only shows systems equipped with economizer).

NOTE - In order to understand how these optional controls affect the operation of the GCS16, you must first understand how all GCS16 components work. Refer to the operation sequence for basic unit operation.

WARNING - CONNECT ONLY RELAY KITS DESIGNED FOR THIS CONTROL SYSTEM. RELAY KITS FOR OTHER CONTROL SYSTEMS ARE NOT COMPATIBLE AND CONTROL DAMAGE OR FAILURE WILL RESULT. FOR EXAMPLE, NEVER CONNECT A W973 RELAY KIT TO A W7400 CONTROL SYSTEM.

CAUTION - DO NOT CONNECT A WARM-UP KIT TO JACK J5 OF THE W7400 RELAY KIT. THE WIRING OF THE WARM-UP KIT IS NOT COMPATIBLE WITH THE WIRING OF THE W7400 CONTROL SYSTEM AND DAMAGE TO COMPONENTS WILL RESULT IF CONNECTED. THE W7400 SYSTEM HAS A WARM-UP FEATURE BUILT-IN. A WARM-UP KIT IS NOT NEEDED.

This control arrangement does not require field installed pigtailed. The W7400 plugs in to the GCS16 in the control mounting area of the blower compartment. Jack J17 connects to plug P16. Plug P17 then connects to jack J16 (figure 94).

The W7400 relay kit mounts next to the W7400 control in the control mounting area of the GCS16 units blower compartment. No hard wiring is required. Jumper plug P3 is removed and discarded. Relay kit plug P5 connects directly to jack J3 in the blower compartment (figure 95).

The economizer plugs in to the relay kit. Economizer plug P4 connects directly to jack J5 of the W7400 relay kit.

IMPORTANT - P14 MUST BE DISCONNECTED FROM J23 IN THIS APPLICATION ONLY. IMPROPER UNIT OPERATION WILL RESULT IF P14 IS NOT DISCONNECTED.

IMPORTANT - DISCONNECT J26 FROM P26 AND CONNECT J28 TO P26 IN THIS APPLICATION ONLY. IMPROPER UNIT OPERATION WILL RESULT IF PROPER CONNECTIONS ARE NOT MADE.

Operation Sequence:

- 1- Relay K11 (not shown) is not used in this application and should not be installed.
- 2- Economizer minimum position and warm-up are controlled through terminals A and C on the W7400 control. Outdoor air dampers are held closed during morning warm-up and at mid (minimum) position during all other unit operation. Dampers are held closed when the unit is not operating.
- 3- Heat demand W1 from thermostat T7400 is routed through the W7400 directly to the heat section of the GCS16.
- 4- Increased heat demand from the T7400 is not used.
- 5- Economizer outdoor air dampers are held closed anytime heat demand is not present (relay contacts K13-2) or blower is not operating (relay contacts K3-2).

Cooling:

I. Enthalpy Control in Low Position (outside air can be used for cooling).

First stage cool (all models):

- 6- Enthalpy control A6 has determined that outside air can be used for cooling and has switched internal 1K and 2K internally. Since J26 is disconnected from P26 there is no affect.
- 7- Cooling demand Y1 is routed through N.C. K12-1 contacts 1-9 and through discharge air thermostat S13 to enthalpy control terminal D and damper motor terminal D.
- 8- When 24VAC is applied across terminals D and T of damper motor, the damper motor energizes and outdoor dampers open fully. First stage cooling is provided by outdoor air.

Second stage cool (all models):

- 9- Economizer outdoor air dampers remain open.
- 10- Additional cooling demand is routed from thermostat Y2 through enthalpy control terminals 3 and 5 to energize the compressor. The compressor provides all additional cooling demand.

II. Enthalpy Control in High Position (outside air cannot be used for cooling).

- 11- Enthalpy control A6 has determined that outside air cannot be used for cooling and has switched 1K and 2K internally. Relay K12 is energized. K12-1 contacts switch to allow compressor to provide cooling and K12-2 open to tell W7400 that outside air is no longer available for cooling.
- 12- Cooling demand Y1 is sent from through K12-1 N.O. contacts 9-5 to GCS16 compressor circuit. The compressor handles all cooling demand.

Night Setback

- 13- Night setback and morning warm-up functions are controlled internally in the W7400. Operation sequence does not change.

C7-3 diagram with D5 diagram W7400 Control with modulating economizer

24V POWER

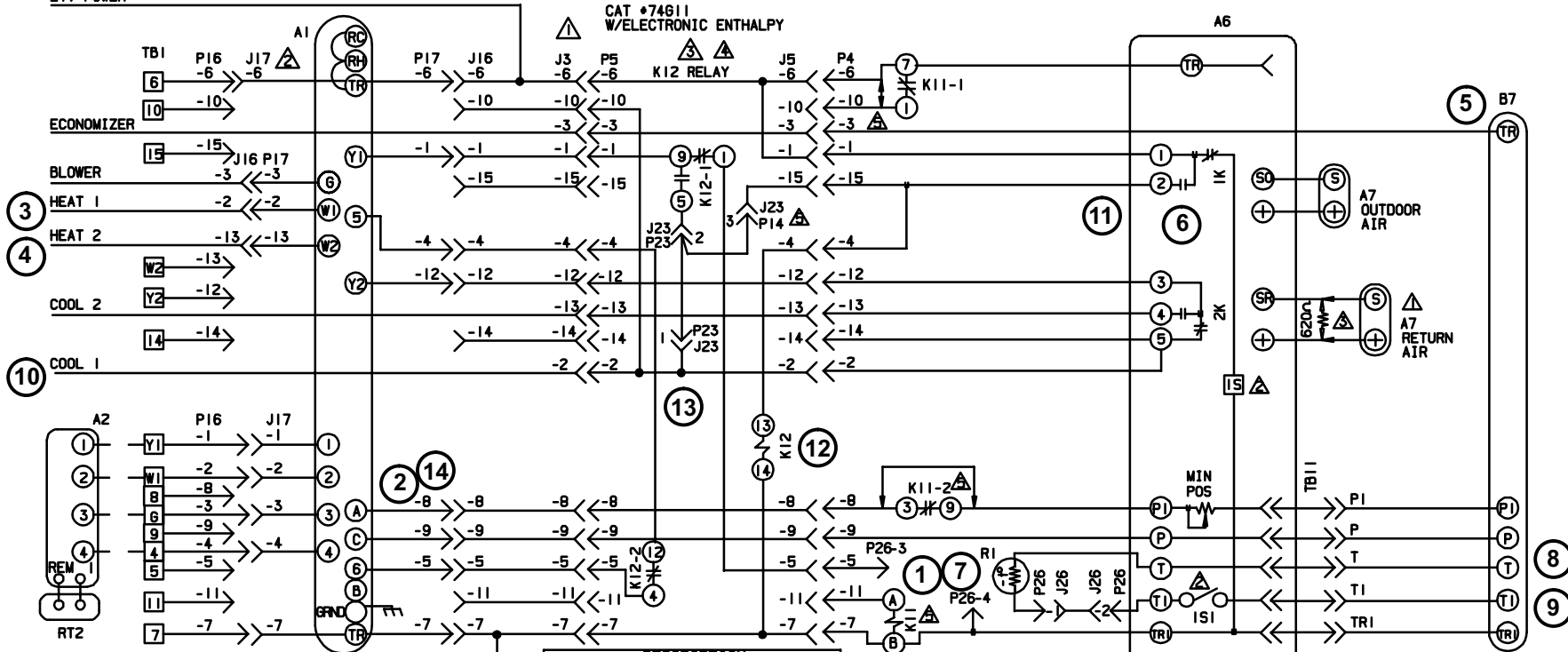

24V COMMON — LOW VOLTAGE FIELD WIRING
 — FACTORY WIRING

Thermostat Footnotes

- ⚠ FOR USE WITH ECONOMIZER SECTION OR LVAV
- ⚠ USE RELAY KIT WITH ECONOMIZER. WITHOUT ECONOMIZER USE P3
- ⚠ P23 IS USED FOR NORMAL SINGLE ZONE APPLICATIONS. P14 IS USED FOR LVAV APPLICATIONS ONLY
- ⚠ TO INSTALL W7400 MODULE, DISCONNECT P16 FROM J16 (IN UNIT CONTROL BOX) CONNECT J17 TO P16, AND P17 TO P16
- ⚠ J3 MAXIMUM LOAD 20VA 24VAC CLASS II

Economizer Footnotes

- ⚠ OPTIONAL-SECOND A7 INSTALLED IN RETURN AIR PROVIDES DIFFERENTIAL ENTHALPY CONTROL
- ⚠ WHEN IS RECEIVES POWER, ISI CLOSES.
- ⚠ FACTORY INSTALLED 620 OHM, 1 WATT, 5% RESISTOR. REMOVE WHEN SECOND A7 SENSOR IS INSTALLED TO PROVIDE DIFFERENTIAL ENTHALPY CONTROL
- ⚠ WHEN W7400 CONTROL IS USED, REMOVE J26 JUMPER AND INSTALL J28. J28 AND K7 RELAY ARE PART OF W7400 KIT (74G11)
- ⚠ K11 NITE RELAY MAY NOT BE PART OF ECONOMIZERS ON UNITS BELOW 7.5T CAPACITY

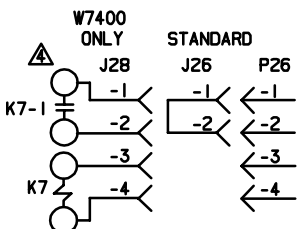

LENNOX Industries Inc. WIRING DIAGRAM		9/88
ACCESS-COMBINATION UNITS-ROOFTOP		
THERMOSTAT FOR		
GCS, CHA, CHP16 SERIES UNITS		
WITH W7400 CONTROL OPTION		
THERMOSTAT SECTION-C7-3		
Supersedes Form No.	New Form No.	

KEY	DESCRIPTION
A6	control-enthalpy W7459A
A7	sensor-enthalpy
B7	motor-damper
J26	jack-enthalpy
J28	jack-W7400
K7-1	relay-W7400
K11-1,2	relay-nite setback
P4	plug-economizer
P26	plug-enthalpy
R1	sensor-supply air
TBI1	strip-terminal

KEY	DESCRIPTION
A1	control module W7400
A2	thermostat-room T7400
J3	jack-economizer
J5	jack-W7400
J16	jack-unit
J17	jack-module
J23	jack-jumper
K12-1,-2	relay-setpoint W7400
P5	plug-warm up W7400
P14	plug-jumper LVAV
P16	plug-unit
P17	plug-module
P23	plug-jumper
RT2	sensor-remote (optional)
TBI	block-terminal (low volt)

LENNOX Industries Inc. WIRING DIAGRAM		4/89
ACCESS-COMBINATION UNITS-ROOFTOP		
REMD16M	EMDH16M	
REMD11M	EMD17-95/135	
(MODULATING ECONOMIZER)		
ECONOMIZER-SECTION D5		
Supersedes Form No.	New Form No.	

C7-3 DIAGRAM WITH D5 DIAGRAM

Honeywell W7400 Control System and T7400 Thermostat with Modulating Economizer

2-C7-3 Section with D5 Section

The Honeywell W7400 control / T7400 thermostat system, when applied to a GCS16 allows fully programmable operation of the unit during occupied or unoccupied periods. Morning warm-up capabilities are built-in to the control system. An external warm-up kit is not needed and should not be used. This diagram shows a modulating economizer connected to a W7400 control system.

An economizer may be added to the system to allow outside air for cooling. A relay (K12 - figure 95) must be added to interface the control to the economizer. In this sequence of operation, the W7400 relay kit is specially wired to interface the control to an economizer using a solid state enthalpy control. Relay kits for early electromechanical enthalpy controls (as used in D2 wiring diagrams) cannot be used or control damage will result. All economizers for 2-5 ton GCS16 units are equipped with electronic enthalpy controls and the updated relay kit must be used. Unit jackplug J3 must be installed in place of relay kit for basic unit operation without economizer (since it is improbable that a W7400 system be used without economizer, this wiring diagram only shows systems equipped with economizer).

NOTE - In order to understand how these optional controls affect the operation of the GCS16, you must first understand how all GCS16 components work. Refer to the operation sequence for basic unit operation.

WARNING - CONNECT ONLY RELAY KITS DESIGNED FOR THIS CONTROL SYSTEM. RELAY KITS FOR OTHER CONTROL SYSTEMS ARE NOT COMPATIBLE AND CONTROL DAMAGE OR FAILURE WILL RESULT. FOR EXAMPLE, NEVER CONNECT A W973 RELAY KIT TO A W7400 CONTROL SYSTEM.

CAUTION - DO NOT CONNECT A WARM-UP KIT TO JACK J5 OF THE W7400 RELAY KIT. THE WIRING OF THE WARM-UP KIT IS NOT COMPATIBLE WITH THE WIRING OF THE W7400 CONTROL SYSTEM AND DAMAGE TO COMPONENTS WILL RESULT IF CONNECTED. THE W7400 SYSTEM HAS A WARM-UP FEATURE BUILT-IN. A WARM-UP KIT IS NOT NEEDED.

This control arrangement does not require field installed pigtailed. The W7400 plugs in to the GCS16 in the control mounting area of the blower compartment. Jack J17 connects to plug P16. Plug P17 then connects to jack J16 (figure 94).

The W7400 relay kit mounts next to the W7400 control in the control mounting area of the GCS16 blower compartment. No hard wiring is required. Jumper plug P3 is removed and discarded. Relay kit plug P5 connects directly to jack J3 in the blower compartment (figure 95). The economizer plugs in to the relay kit. Economizer plug P4 connects directly to jack J5 of the W7400 relay kit.

IMPORTANT - P14 MUST BE DISCONNECTED FROM J23 IN THIS APPLICATION ONLY. IMPROPER UNIT OPERATION WILL RESULT IF P14 IS NOT DISCONNECTED.

IMPORTANT - DISCONNECT J26 FROM P26 AND CONNECT J28 TO P26 IN THIS APPLICATION ONLY. IMPROPER UNIT OPERATION WILL RESULT IF PROPER CONNECTIONS ARE NOT MADE.

Operation Sequence:

- 1- Relay K11 (not furnished) is not used in this application and should not be installed.
- 2- Economizer minimum position and warm-up are controlled through terminals A and C on the W7400 control. Outdoor air dampers are held closed during morning warm-up and at minimum position during all other unit operation. Dampers are held closed when the unit is not operating.
- 3- Heat demand W1 from thermostat T7400 is routed through the W7400 directly to the heat section of the GCS16.
- 4- Increased heat demand from the T7400 is not used.
- 5- Economizer outdoor air dampers are held closed any time heat demand is not present (relay contacts K13-2) or blower is not operating (relay contacts K3-2).

Cooling:

I. Enthalpy Control in Low Position (outside air can be used for cooling).

First stage cool (all models):

- 6- Enthalpy control A6 has determined that outside air can be used for cooling and has switched 1K and 2K internally. Internal relay 1S is energized. Internal contacts 1S1 close to complete a circuit through damper motor terminals T and T1.
- 7- Cooling demand Y1 is sent through N.C. K12-1 contacts 1-9. There is no affect. However, blower demand allows outdoor dampers to modulate open.
- 8- When a voltage is applied across terminals T and T1 of damper motor, the damper motor energizes and outdoor dampers open. Supply air sensor R1 varies the voltage across T and T1 and the outdoor air dampers adjust accordingly. First stage cooling is provided by outdoor air.

Second stage cool (all models):

- 9- Economizer outdoor air dampers remain open.
- 10- Additional cooling demand is routed from thermostat Y2 through enthalpy control terminals 3 and 5 to energize the compressor. The compressor provides all additional cooling.

II. Enthalpy Control in High Position (outside air cannot be used for cooling).

- 11- Enthalpy control internal relays 1K and 2K switch. Internal relay 1S is de-energized and 1S1 opens. Outdoor air dampers close to minimum position.
- 12- Relay K12 is energized. K12-1 contacts switch to allow compressor to provide cooling and K12-2 open to tell W7400 that outside air is no longer available for cooling.
- 13- Cooling demand Y1 is sent through K12-1 N.O. contacts 9-5 to GCS16 compressor circuit. The compressor handles all cooling demand.

Night Setback (optional field installed)

- 14- Night setback and morning warm-up functions are controlled internally in the W7400. Operation sequence does not change.

C8-1 diagram W973 Control

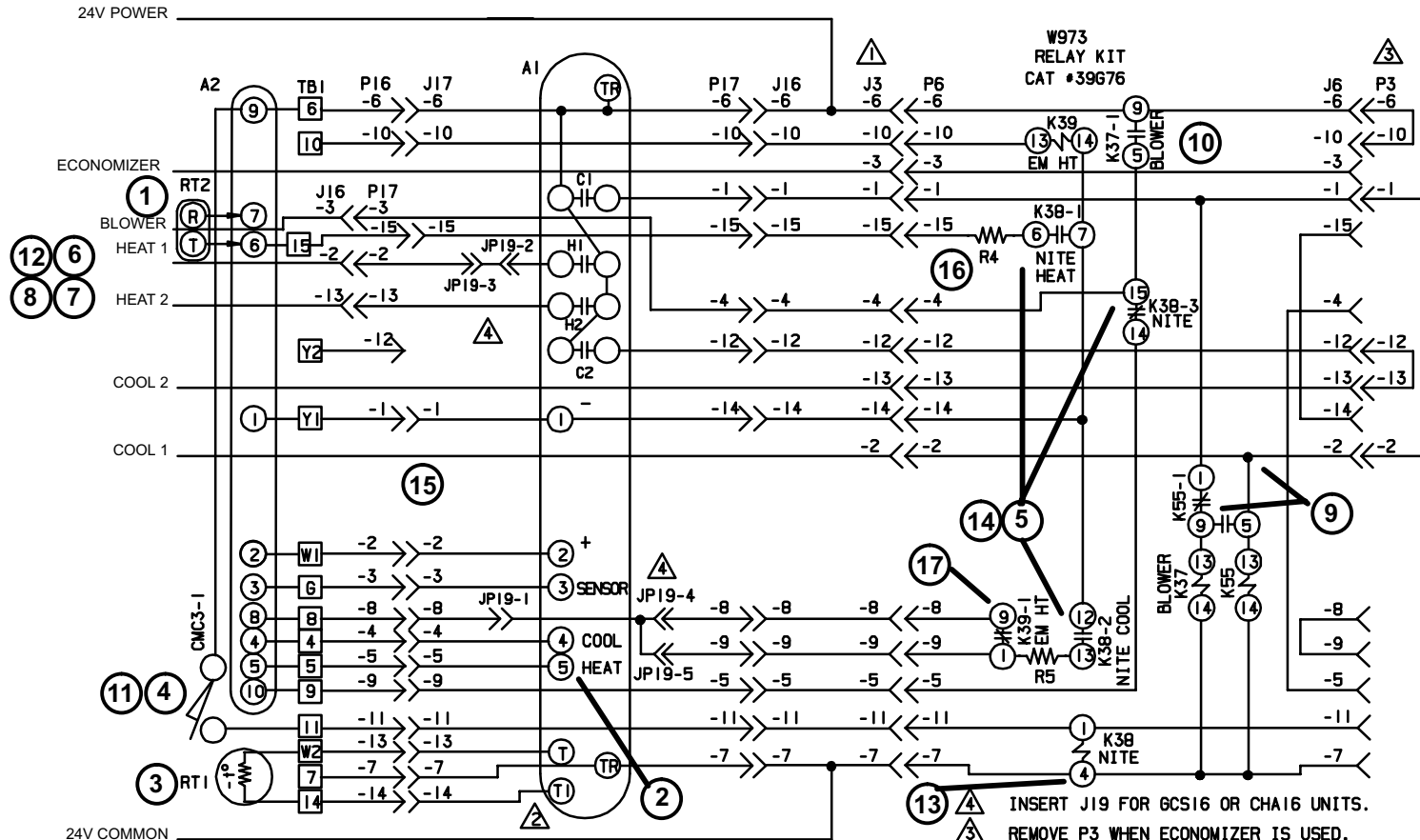

KEY	DESCRIPTION
	COMPONENT
A1	control-module W973
A2	thermostat-room T7067
CMC3-1	timer-clock
J3	jack-economizer
J6	jack-W973 kit
J16	jack-unit
J17	jack-module
JP19	jack-plug select CHA/GCS
K37-1	relay-blower W973 kit
K38-1,2,3	relay-emerg ht W973 kit
K39-1	relay-nite W973 kit
K55-1	relay-blower LVAV
P3	plug-economizer
P6	plug-W973 kit

KEY	DESCRIPTION
	COMPONENT
P16	plug-unit
P17	plug-module
R4	resistor-nite heat 3.6K Ω
R5	resistor-nite cool 1.2K Ω
RT1	sensor-discharge
RT2	sensor-remote (optional)
TB1	block-terminal (low volt)

- 13 Δ INSERT J19 FOR GCS16 OR CHA16 UNITS.
- 3 Δ REMOVE P3 WHEN ECONOMIZER IS USED.
- 2 Δ TO INSTALL W973 MODULE, DISCONNECT P16 FROM J16 (IN UNIT CONTROL BOX) CONNECT J17 TO P16, AND P17 TO J16.
- 1 Δ J3 MAXIMUM LOAD 20VA 24VAC CLASS II

LENNOX Industries Inc. WIRING DIAGRAM 9/88

ACCESS-COMBINATION UNITS-ROOFTOP

THERMOSTAT FOR
GCS, CHA11 & 16 SERIES
UNITS WITH W973

THERMOSTAT SECTION-C8-1

Supersedes Form No. _____ New Form No. _____

C8-1 DIAGRAM

Honeywell W973 Control System and T7067 Thermostat without Economizer

3-C8-1 Section

Honeywell W973 control, when added to the GCS16 system, allows use of electronic ramping thermostats, discharge temperature sensors, return air temperature sensors and/or remote thermostats and transmitters. W973 control system is designed for use with Honeywell T7067 electronic ramping thermostat and Q667 subbase. Interconnecting W973 relay kit must be used to adapt W973 to the GCS16.

NOTE - In order to understand how these optional controls affect the operation of the GCS16, you must first understand how all GCS16 components work. Refer to the operation sequence for basic unit operation.

NOTE - Use of Honeywell W973 controller with the GCS16 requires use of W973 relay kit and CMC3-1 time clock. This arrangement is designed for use with Honeywell T7067 electronic ramping thermostat and Honeywell Q667 subbase or equivalent. Remote setpoint transmitter with return air temperature sensor or room temperature sensor may be used in place of room thermostat. None of the thermostat/sensor combinations affect the following operation sequence.

The W973 plugs in to the GCS16 inside the control make-up area of the GCS16 blower compartment (see figure 97). Jack J17 connects to unit plug P16. Then plug P17 connects to jack J16. Jumper plug J19 supplied with the W973 must be connected to plug P19 on the W973. Jumper plug J12 also supplied with the W973 is not used with GCS16 series units and may be discarded.

The W973 relay kit mounts inside the control make-up area of the GCS16 blower compartment next to the W973. No wiring is required. GCS16 jumper plug P3 is removed and discarded. Warm-up kit harness plug P6 connects directly into GCS16 jack J3 in the blower compartment.

WARNING - CONNECT ONLY RELAY KITS DESIGNED FOR THIS CONTROL SYSTEM. RELAY KITS DESIGNED FOR OTHER CONTROL SYSTEMS ARE NOT COMPATIBLE AND CONTROL DAMAGE OR FAILURE WILL RESULT. FOR EXAMPLE, A W7400 RELAY KIT MUST NEVER BE CONNECTED TO A W973 CONTROL SYSTEM.

Operation Sequence:

- 1-Room temperature is controlled by a thermistor located in A2 (T7067A) thermostat or remote A2 (T7067B) transmitter (RT2). As room temperature changes, thermistor resistance also changes. If room temperature goes up, thermistor resistance goes down. If room temperature goes down, thermistor resistance goes up. The thermistor allows $2.5V/F^{\circ}$ ($1.4V/C^{\circ}$). When the cooling setpoint is crossed, the T7067 begins transmitting a cooling ramp from terminal 4 through TB1-4 to terminal 4 of A1. As room temperature increases, the cooling ramp increases from 1 to 16 VDC. When the heating setpoint is crossed, the T7067 begins transmitting a heating ramp from terminal 5 through TB1-5 to terminal 5 of A1. As room temperature increases, the cooling ramp increases from 1 to 16 VDC.

- 2- Generally, A1 cooling contacts C1 close when voltage input to A1 terminal 4 reaches 4VDC. C2 cooling contacts close when voltage input to A1 terminal 4 increases to 5 VDC. A1 heating contacts H1 close when voltage input to A1 terminal 5 reaches 4 VDC and H2 contacts close when the voltage ramp increases to 5 VDC.
- 3- To provide anticipation, discharge sensor RT1 modifies the voltage that A1 receives at terminals 4 & 5. If discharge temperature goes up, RT1 resistance goes down. For every 25°F change in discharge temperature, A1 will offset the setpoint 1°F. As a result, RT1 may require a higher or lower voltage input to A1 terminals 4 or 5 before closing C1, C2, H1 or H2.

Day Operation (Occupied Period):

- 4- Time clock CMC3-1 contacts open. Relay K38 in relay kit de-energizes.
- 5- Contacts K38-1 open, removing setback resistor R4 from the circuit. Contacts K38-2 open, removing setup resistor R5 from the circuit. Contacts K38-3 close, control of blower B3 is shifted to A2 terminal 10. During day operation when contacts K38-3 are closed, blower B3 is controlled by A2 terminal 10 and can operate in ON or AUTO modes.
- 6- Heat demand (ramp from A2 terminal 5) closes H1. First stage heat energizes.
- 7- Increased heating demand (increased voltage from A2 terminal 5) closes H2 (not used in this application).
- 8- When the heating demand is satisfied, heating section of GCS16 is de-energized.
- 9- Cool demand (ramp from A2 terminal 4) closes C1. Demand passes through P3 to energize cooling section of GCS16 and through N.C. K55-1 contacts to energize relay K37. Relay K55 (used for LVAV only) simultaneously energizes and K55-1 N.O. contacts close to keep relay K37 energized.
- 10- When K37-1 closes, the blower is energized on cooling speed.

Night Setback (optional field installed)

- 11- Optional field installed time clock must be connected for night setback operation.
- 12- Blower B3 operates only during a heating demand during setback.
- 13- When clock contacts close, relay K38 energizes.
- 14- Contacts K38-1 close to energize setback resistor R4. Contacts K38-2 close to energize setup resistor R5. Contacts K38-3 open to energize blower B3 on demand only. During night operation when contacts K38-3 are open, blower B3 operates only on demand powered by relay K25 (in GCS16 - for heat) or K37 (for cool).
- 15- A1 terminal 1 feeds 20VDC at all times to A2 terminal 1 and K38-1 and K38-2 (source of voltage for resistors in relay kit).
- 16- When heating demand is present during unoccupied periods, 20VDC feeds through K38-1 and R4. R4 alters the voltage. A2 terminal 6 receives that altered voltage and uses it to shift the unoccupied setpoint. R4's value, 3.6K ohms, shifts the unoccupied setpoint down 10°F. For example, if heat lever of A2 is set at 75°F, the unoccupied setpoint for 1st stage operation is 65°F.
- 17- When cooling demand is present during unoccupied periods, 20VDC feeds through K38-2 and R5. R5 alters the voltage. A2 terminal 8 receives that altered voltage and uses it to shift the unoccupied setpoint. R5's value, 1.2K ohms, locks out cooling in unoccupied mode.

C8-1 diagram with D8 diagram W973 Control with three-position economizer

24V POWER

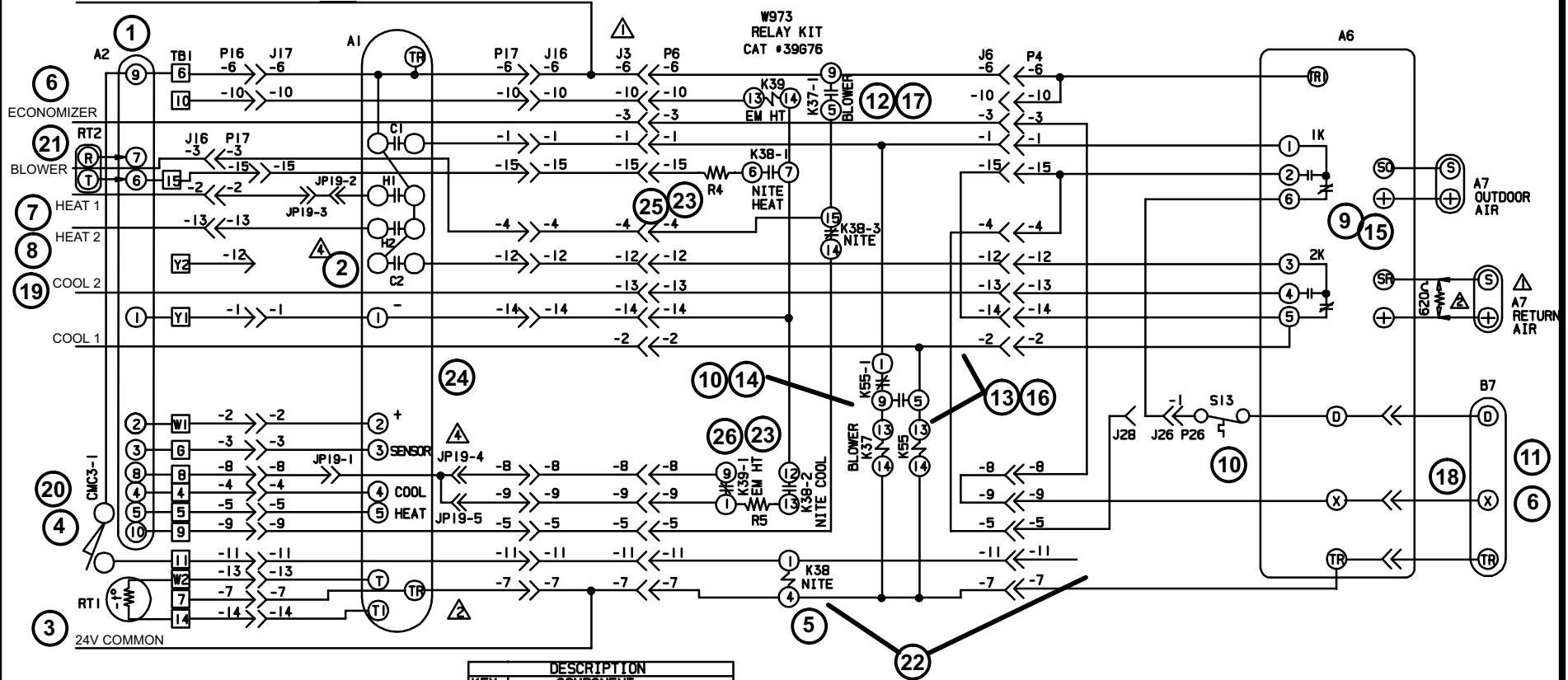

Page 123

- Thermostat Footnotes**
- ⚠ INSERT J19 FOR GCS16 OR CHA16 UNITS.
 - ⚠ REMOVE P3 WHEN ECONOMIZER IS USED.
 - ⚠ TO INSTALL W973 MODULE, DISCONNECT P16 FROM J16 (IN UNIT CONTROL BOX) CONNECT J17 TO P16, AND P17 TO J16.
 - ⚠ J3 MAXIMUM LOAD 20VA 24VAC CLASS II

LENNOX Industries Inc. WIRING DIAGRAM 9/88

ACCESS-COMBINATION UNITS-ROOFTOP

THERMOSTAT FOR
GCS, CHA11 & 16 SERIES
UNITS WITH W973

THERMOSTAT SECTION-C8-1

Supersedes Form No. _____ New Form No. _____

Litho U.S.A.

KEY	DESCRIPTION
P16	plug-unit
P17	plug-module
R4	resistor-nite heat 3.6K Ω
R5	resistor-nite cool 1.2K Ω
RT1	sensor-discharge
RT2	sensor-remote (optional)
TB1	block-terminal (low volt)

KEY	DESCRIPTION
A1	control-module W973
A2	thermostat-room T7067
CMC3-1	timer-clock
J3	jack-economizer
J6	jack-W973 kit
J16	jack-unit
J17	jack-module
JP19	jack-plug select CHA/GCS
K37-1	relay-blower W973 kit
K38-1,2,3	relay-emerg hi W973 kit
K39-1	relay-nite W973 kit
K55-1	relay-blower LVAV
P3	plug-economizer
P6	plug-W973 kit

KEY	DESCRIPTION
A6	control-enthalpy (W7459C)
A7	sensor-enthalpy
B7	motor-damper
J26	jack-enthalpy
J28	jack-W7400
P4	plug-economizer
P26	plug-enthalpy
S13	thermostat-discharge air

- Economizer Footnotes**
- ⚠ OPTIONAL-SECOND A7 INSTALLED IN RETURN AIR PROVIDES DIFFERENTIAL ENTHALPY CONTROL
 - ⚠ FACTORY INSTALLED 620 OHM, 1 WATT, 5% RESISTOR. REMOVE WHEN SECOND A7 SENSOR IS INSTALLED TO PROVIDE DIFFERENTIAL ENTHALPY CONTROL

LENNOX Industries Inc. WIRING DIAGRAM 4/89

ACCESS-COMBINATION UNITS-ROOFTOP

REMD16 SERIES
EMD16 SERIES
(3 POSITION)

ECONOMIZER-SECTION D8

Supersedes Form No. _____ New Form No. _____

Litho U.S.A.

C8-1 DIAGRAM WITH D8 DIAGRAM

Honeywell W973 Control System and T7067 Thermostat with Three-position Economizer

4-C8-1 Section with D8 Section

An REMD16/EMDH16 economizer added to a GCS16 with a Honeywell W973 Control allows the use of outside air for first stage cooling controlled by an enthalpy control and electronic ramping thermostats. Discharge temperature sensors, return air temperature sensors and/or remote thermostats and transmitters may also be used.

NOTE - In order to understand how these optional controls affect the operation of the GCS16, you must first understand how all GCS16 components work. Refer to the operation sequence for basic unit operation.

NOTE - Use of the Honeywell W973 controller with the GCS16 requires use of the W973 relay kit and CMC3-1 time clock. This arrangement is designed for use with Honeywell T7067 electronic ramping thermostat and Honeywell Q667 subbase or equivalents. A remote setpoint transmitter with either a return air temperature sensor or a room temperature sensor may be used in place of the room thermostat. None of the thermostat/sensor combinations affect the following operation sequence.

The W973 plugs in to the GCS16 inside the control make-up area of the GCS16 blower compartment (see figure 98). Jack J17 connects to unit plug P16. Then plug P17 connects to jack J16. Jumper plug J19 supplied with the W973 must be connected to plug P19 on the W973. Jumper plug J12 also supplied with the W973 is not used with GCS16 series units and may be discarded.

The W973 relay kit mounts inside the control make-up area of the GCS16 blower compartment next to the W973. No wiring is required. GCS16 jumper plug P3 is removed and discarded. Warm-up kit harness plug P6 connects directly into GCS16 jack J3 in the blower compartment.

WARNING - CONNECT ONLY RELAY KITS DESIGNED FOR THIS CONTROL SYSTEM. RELAY KITS DESIGNED FOR OTHER CONTROL SYSTEMS ARE NOT COMPATIBLE AND CONTROL DAMAGE OR FAILURE WILL RESULT. FOR EXAMPLE, A W7400 RELAY KIT MUST NEVER BE CONNECTED TO A W973 CONTROL SYSTEM.

Operation Sequence:

- 1-Room temperature is controlled by a thermistor located in A2 (T7067A) thermostat or remote A2 (T7067B) transmitter (RT2). As room temperature changes, thermistor resistance also changes. If room temperature goes up, thermistor resistance goes down. If room temperature goes down, thermistor resistance goes up. The thermistor allows $2.5V/F^{\circ}$ ($1.4V/C^{\circ}$). When the cooling setpoint is crossed, the T7067 begins transmitting a cooling ramp from terminal 4 through TB1-4 to terminal 4 of A1. As room temperature increases, the cooling ramp increases from 1 to 16 VDC. When the heating setpoint is crossed, the T7067 begins transmitting a heating ramp from terminal 5 through TB1-5 to terminal 5 of A1. As room temperature increases, the cooling ramp increases from 1 to 16 VDC.
- 2- Generally, A1 cooling contacts C1 close when voltage input to A1 terminal 4 reaches 4VDC. C2 cooling contacts close when voltage input to A1 terminal 4 increases to 5 VDC. A1 heating contacts H1 close when voltage input to A1 terminal 5 reaches 4 VDC and H2 contacts close when the voltage ramp increases to 5 VDC.

- 3- To provide anticipation, discharge sensor RT1 modifies the voltage that A1 receives at terminals 4 & 5. If discharge temperature goes up, RT1 resistance goes down. For every $25^{\circ}F$ change in discharge temperature, A1 will offset the setpoint $1^{\circ}F$. As a result, RT1 may require a higher or lower voltage input to A1 terminals 4 or 5 before closing C1, C2, H1 or H2.

Day Operation (Occupied Period):

- 4- Time clock CMC3-1 contacts open. Relay K38 in relay kit de-energizes.
- 5- Contacts K38-1 open, removing setback resistor R4 from the circuit. Contacts K38-2 open, removing setup resistor R5 from the circuit. Contacts K38-3 close, control of blower B3 is shifted to A2 terminal 10. During day operation when contacts K38-3 are closed, blower B3 is controlled by A2 terminal 10 and can operate in ON or AUTO modes.
- 6- Power is supplied to the economizer continuously through blower relay K3-2. Dampers open to minimum position during blower operation.
- 7- Initial heat demand (voltage ramp from A2 terminal 5) closes H1. First stage heat energizes.
- 8- Increased heating demand (increased voltage from A2 terminal 5) closes H2 (not used in this application).

Enthalpy Low (outside air can be used for cooling):

- 9- Enthalpy control has determined that outside air can be used for cooling. Internal relays switch to close a circuit from 1k terminal 1 to 6 and from 2K terminal 3 to 5.
- 10-Cooling demand is routed through enthalpy control terminal 1 and 6 and through discharge air thermostat S13 to enthalpy control terminal D and damper motor terminal D. Simultaneously, cooling demand energizes relay K37.
- 11- When 24VAC is applied across terminals D and TR of damper motor, the damper motor energizes and outdoor dampers open fully. Outdoor air dampers drive full closed anytime blower B3 is not operating.
- 12- Contacts K37-1 close to energize blower on cooling speed.
- 13- Additional cooling demand is routed through enthalpy control terminals 1 and 2 and through terminal 5 to energize the compressor and relay K55. The compressor provides all additional cooling.
- 14- Contacts K55-1 switch to energize relay K37. Contacts K37-1 close to energize blower on cooling speed.

Cooling Demand Enthalpy High:

- 15- Enthalpy control internal relays switch to close a circuit from 1k terminal 1 to 2 and from 2K terminal 3 to 4. Outdoor air dampers close.
- 16- Cooling demand is routed through enthalpy control terminals 1 and 2 and terminal 5 to energize the compressor and relays K37 and K55. The compressor handles all cooling demand.
- 17- Contacts K37-1 close to energize blower on cooling speed. Simultaneously, contacts K55-1 switch (no affect).
- 18- Blower demand energizes blower relay K3 in the unit. Contacts K3-1 close to energize the blower and contacts K3-2 close to energize the economizer. When 24VAC is applied between damper motor terminals X and TR, the outdoor air dampers open to mid (minimum) position. Dampers remain open when blower B3 is operating and close when B3 is not operating.
- 19- Increased cooling demand is not used in this application (In terms of providing additional cooling).

continued on next page

C8-1 DIAGRAM WITH D8 DIAGRAM

Night Setback (optional field installed)

- 20- Optional field installed time clock and night relay K11 must be connected for night setback operation.
- 21- Blower B3 operates only during a heating demand when night thermostat is closed. Energized by relay K25 in unit.
- 22- When clock contacts close, relays K11 and K38 energize.
- 23- Contacts K38-1 close to energize setback resistor R4.
Contacts K38-2 close to energize setup resistor R5.
Contacts K38-3 open to energize blower B3 on demand only.
During night operation when contacts K38-3 are open, blower B3 operates only on demand powered through relays K25 (for heat) or K37 (for cool). Outdoor air dampers are held closed by contacts K11-2 remaining open (not shown).
- 24- A1 terminal 1 feeds 20VDC at all times to A2 terminal 1 and contacts K38-1 and K38-2 (source of voltage for resistors in relay kit).
- 25- When heating demand is present during unoccupied periods, 20VDC feeds through K38-1 and R4. R4 alters the voltage. A2 terminal 6 receives that altered voltage and uses it to shift the unoccupied setpoint. R4's value, 3.6K ohms, shifts the unoccupied setpoint down 10°F. For example, if heat lever of A2 is set at 75°F, the unoccupied setpoint for first stage operation is 65°F.
- 26- When cooling demand is present during unoccupied periods, 20VDC feeds through K38-2 and R5. R5 alters the voltage. A2 terminal 8 receives that altered voltage and uses it to shift the unoccupied setpoint. R5's value, 1.2K ohms, locks out cooling in unoccupied mode.

C8-1 diagram with D5 diagram W973 Control with modulating economizer

24V POWER

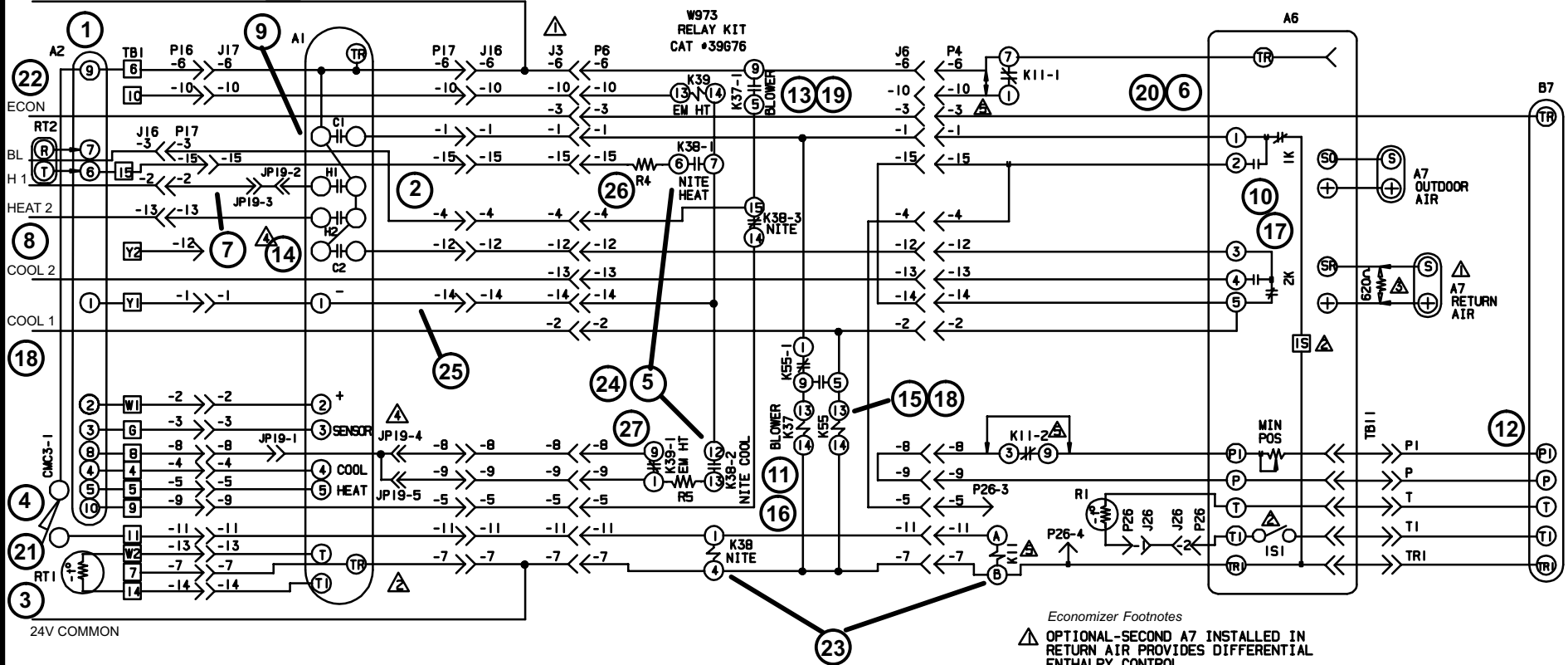

24V COMMON

Page 126

Thermostat Footnotes

- ▲ INSERT J19 FOR GCS16 OR CHA16 UNITS.
- ▲ REMOVE P3 WHEN ECONOMIZER IS USED.
- ▲ TO INSTALL W973 MODULE, DISCONNECT P16 FROM J16 (IN UNIT CONTROL BOX) CONNECT J17 TO P16, AND P17 TO J16.
- ▲ J3 MAXIMUM LOAD 20VA 24VAC CLASS II

Economizer Footnotes

- ▲ OPTIONAL-SECOND A7 INSTALLED IN RETURN AIR PROVIDES DIFFERENTIAL ENTHALPY CONTROL
- ▲ WHEN ISI RECEIVES POWER, ISI CLOSES.
- ▲ FACTORY INSTALLED 620 OHM, 1 WATT, 5% RESISTOR. REMOVE WHEN SECOND A7 SENSOR IS INSTALLED TO PROVIDE DIFFERENTIAL ENTHALPY CONTROL
- ▲ WHEN W7400 CONTROL IS USED, REMOVE J26 JUMPER AND INSTALL J28. J28 AND K7 RELAY ARE PART OF W7400 KIT (74611)
- ▲ K11 NITE RELAY MAY NOT BE PART OF ECONOMIZERS ON UNITS BELOW 7.5T CAPACITY

LENNOX Industries Inc. WIRING DIAGRAM 9/88

ACCESS-COMBINATION UNITS-ROOFTOP

THERMOSTAT FOR
GCS, CHA11 & 16 SERIES
UNITS WITH W973

THERMOSTAT SECTION-C8-1

Supersedes Form No. _____ New Form No. _____

KEY	DESCRIPTION	COMPONENT
A1	control-module	W973
A2	thermostat-room	T7067
CMC3-1	timer-clock	
J3	jack-economizer	
J6	jack-W973 kit	
J16	jack-unit	
J17	jack-module	
JP19	jack-plug select CHA/GCS	
K37-1	relay-blower	W973 kit
K38-1,2,3	relay-emerg ht	W973 kit
K39-1	relay-nite	W973 kit
K55-1	relay-blower	LVAV
P3	plug-economizer	
P6	plug-W973 kit	

KEY	DESCRIPTION	COMPONENT
P16	plug-unit	
P17	plug-module	
R4	resistor-nite heat	3.6K \pm 5%
R5	resistor-nite cool	1.2K \pm 5%
R1	sensor-discharge	
RT2	sensor-remote (optional)	
TB1	block-terminal	(low volt)

KEY	DESCRIPTION	COMPONENT
A6	control-enthalpy	W7459A
A7	sensor-enthalpy	
B7	motor-damper	
J26	jack-enthalpy	
J28	jack-W7400	
K7-1	relay-W7400	
K11-1,2	relay-nite setback	
P4	plug-economizer	
P26	plug-enthalpy	
R1	sensor-supply air	
TB11	strip-terminal	

LENNOX Industries Inc. WIRING DIAGRAM 4/89

ACCESS-COMBINATION UNITS-ROOFTOP

REMD16M EMDH16M
REMD11M EMD17-95/135
(MODULATING ECONOMIZER)

ECONOMIZER-SECTION D5

Supersedes Form No. _____ New Form No. _____

Litho U.S.A.

Litho U.S.A.

C8-1 DIAGRAM WITH D5 DIAGRAM

Honeywell W973 Control System and T7067 Thermostat with Modulating Economizer

5-C8-1 Section with D5 Section

An economizer REMD16M/EMDH16M added to a GCS16 with a Honeywell W973 Control allows the use of outside air for 1st stage cooling controlled by an enthalpy control and electronic ramping thermostats. Discharge temperature sensors, return air temperature sensors and/or remote thermostats and transmitters may also be used.

NOTE - In order to understand how these optional controls affect the operation of the GCS16, you must first understand how all GCS16 components work. Refer to the operation sequence for basic unit operation.

NOTE - Use of the Honeywell W973 controller with the GCS16 requires use of the W973 relay kit and CMC3-1 time clock. This arrangement is designed for use with Honeywell T7067 electronic ramping thermostat and Honeywell Q667 subbase or equivalents. A remote setpoint transmitter with either a return air temperature sensor or a room temperature sensor may be used in place of the room thermostat. None of the thermostat/sensor combinations affect the following operation sequence.

The W973 plugs-in to the GCS16 inside the control make-up area of the GCS16 blower compartment (see figure 98). Jack J17 connects to unit plug P16. Then plug P17 connects to jack J16. Jumper plug J19 supplied with the W973 must be connected to plug P19 on the W973. Jumper plug J12 also supplied with the W973 is not used with GCS16 series units and may be discarded.

The W973 relay kit mounts inside the control make-up area of the GCS16 blower compartment next to the W973. No wiring is required. GCS16 jumper plug P3 is removed and discarded. Warm-up kit harness plug P6 connects directly into GCS16 jack J3 in the blower compartment.

WARNING - CONNECT ONLY RELAY KITS DESIGNED FOR THIS CONTROL SYSTEM. RELAY KITS DESIGNED FOR OTHER CONTROL SYSTEMS ARE NOT COMPATIBLE AND CONTROL DAMAGE OR FAILURE WILL RESULT. FOR EXAMPLE, A W7400 RELAY KIT MUST NEVER BE CONNECTED TO A W973 CONTROL SYSTEM.

Operation Sequence:

- 1-Room temperature is controlled by a thermistor located in A2 (T7067A) thermostat or remote A2 (T7067B) transmitter (RT2). As room temperature changes, thermistor resistance also changes. If room temperature goes up, thermistor resistance goes down. If room temperature goes down, thermistor resistance goes up. The thermistor allows $2.5V/F^{\circ}$ ($1.4V/C^{\circ}$). When the cooling setpoint is crossed, the T7067 begins transmitting a cooling ramp from terminal 4 through TB1-4 to terminal 4 of A1. As room temperature increases, the cooling ramp increases from 1 to 16 VDC. When the heating setpoint is crossed, the T7067 begins transmitting a heating ramp from terminal 5 through TB1-5 to terminal 5 of A1. As room temperature increases, the cooling ramp increases from 1 to 16 VDC.

- 2- Generally, A1 cooling contacts C1 close when voltage input to A1 terminal 4 reaches 4VDC. C2 cooling contacts close when voltage input to A1 terminal 4 increases to 5 VDC. A1 heating contacts H1 close when voltage input to A1 terminal 5 reaches 4 VDC and H2 contacts close when the voltage ramp increases to 5 VDC.
- 3- To provide anticipation, discharge sensor RT1 modifies the voltage that A1 receives at terminals 4 & 5. If discharge temperature goes up, RT1 resistance goes down. For every $25^{\circ}F$ change in discharge temperature, A1 will offset the setpoint $1^{\circ}F$. As a result, RT1 may require a higher or lower voltage input to A1 terminals 4 or 5 before closing C1, C2, H1 or H2.

Day Operation (Occupied Period):

- 4- Time clock CMC3-1 contacts open. Relay K38 in relay kit de-energizes.
- 5- Contacts K38-1 open, removing setback resistor R4 from the circuit. Contacts K38-2 open, removing setup resistor R5 from the circuit. Contacts K38-3 close, control of blower B3 is shifted to A2 terminal 10. During day operation when contacts K38-3 are closed, blower B3 is controlled by A2 terminal 10 and can operate in ON or AUTO modes.
- 6- Power is supplied to the economizer continuously through blower relay K3-2. Dampers open to minimum position during blower operation.
- 7- Initial heat demand (voltage ramp from A2 terminal 5) closes H1. First stage heat energizes.
- 8- Increased heating demand (increased voltage from A2 terminal 5) closes H2 (not used in this application).

Enthalpy Low:

- 9- Initial cool demand (voltage ramp from A2 terminal 4) closes C1.
- 10- Enthalpy control A6 has determined that outside air can be used for cooling and has switched relays 1K and 2K internally.
- 11- Cooling demand is routed through enthalpy control terminal 1 to energize internal relay 1S. Internal contacts 1S1 close to complete a circuit through damper motor terminals T and T1. Simultaneously, cooling demand energizes relay K37.
- 12- When a voltage is applied across terminals T and T1 of damper motor, the damper motor energizes and outdoor dampers open fully. Supply air sensor R1 varies the voltage across T and T1 and the dampers adjust accordingly. First stage cooling is provided by outdoor air.
- 13- Contacts K37-1 close to energize blower on cooling speed.
- 14- Additional cooling demand (voltage ramp from A2 terminal 4) closes C2.
- 15- Demand is routed from A1 terminal C2 through enthalpy control terminals 3 and 5 to energize the compressor and relay K55. The compressor provides all additional cooling demand.
- 16- Contacts K55-1 switch to energize relay K37. Contacts K37-1 close to energize blower on cooling speed (no affect).

continued on next page

C8-1 DIAGRAM WITH D5 DIAGRAM

Enthalpy High (outside air cannot be used for cooling):

- 17- Enthalpy control switches 1K and 2K internally.
- 18- Cooling demand is sent from A1 terminal C1 through enthalpy control terminals 1 and 2 and through enthalpy control terminal 5 to energize the compressor and relays K37 and K55. The compressor handles all cooling demand.
- 19- Contacts K37-1 close to energize blower on cooling speed. Simultaneously, contacts K55-1 switch (no affect). Blower is energized on cooling speed.
- 20- Blower demand energizes relay K3 in unit. Contacts K3-1 close to energize the blower and contacts K3-2 close to energize the economizer. When 24VAC is applied between damper motor terminal TR and TR1 outdoor dampers open to minimum position.

Night Setback (optional field installed)

- 21- Optional field installed time clock and night relay K11 must be connected for night setback operation.
- 22- Blower B3 operates only during a heating demand.
- 23- When clock contacts close, relays K11 and K38 energize.

- 24- Contacts K38-1 close to energize setback resistor R4. Contacts K38-2 close to energize setup resistor R5. Contacts K38-3 open to energize blower B3 on demand only. During night operation when contacts K38-3 are open. blower B3 operates only on demand powered through relays K25 (for heat) or K37 (for cool). Outdoor air dampers are held closed by contacts K11-2 (not shown) remaining open.
- 25- A1 terminal 1 feeds 20VDC at all times to A2 terminal 1 and contacts K38-1 and K38-2 (source of voltage for resistors).
- 26- When heating demand is present during unoccupied periods, 20VDC feeds through K38-1 and R4. R4 alters the voltage. A2 terminal 6 receives that altered voltage and uses it to shift the unoccupied setpoint. R4's value, 3.6K ohms, shifts the unoccupied setpoint down 10°F. For example, if heat lever of A2 is set at 75°F, the unoccupied setpoint for first stage operation is 65°F.
- 27- When cooling demand is present during unoccupied periods, 20VDC feeds through K38-2 and R5. R5 alters the voltage. A2 terminal 8 receives that altered voltage and uses it to shift the unoccupied setpoint. R5's value, 1.2K ohms, locks out cooling in unoccupied mode.

C14-1 diagram with D8 diagram W973 Control with three-position economizer and warm-up

24V POWER

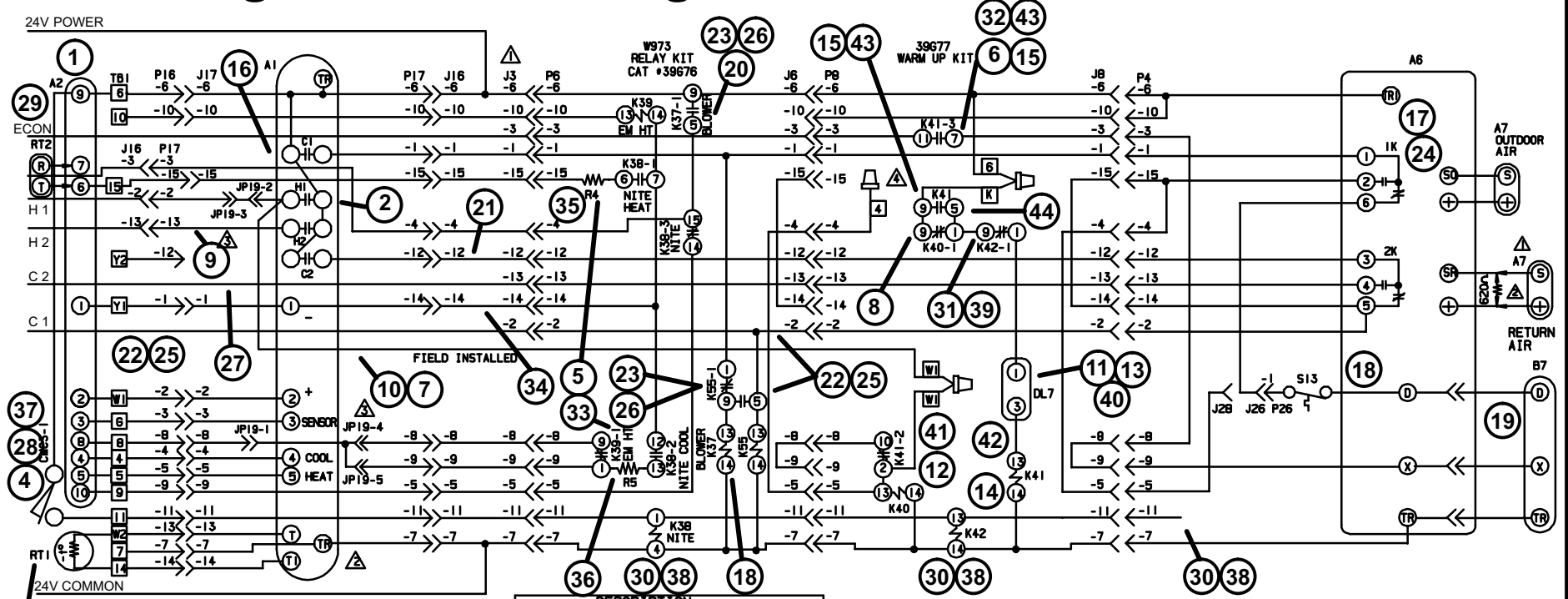

Page 129

KEY	DESCRIPTION
A1	control-module W973
A2	thermostat-room T7067
CMC3-1	timer-clock
DL7	delay-W973 kit
J3	jack-economizer
J6	jack-W973 kit
J8	jack-warm up kit
J16	jack-unit
J17	jack-module
JP19	jack-plug select CHA,GCS
K37-1	relay-blower W973 kit
K38-1,2,3	relay-emerg ht W973 kit
K39-1	relay-nite W973 kit
K40-1	relay-warm up kit h t latch
K41-1,2,3	relay-warm up kit latch

KEY	DESCRIPTION
K42-1	relay-warm up kit/clock
K55-1	relay-blower LVAV
P6	plug-W973 relay kit
P8	plug-warm up kit
P16	plug-unit
P17	plug-module
R4	resistor-nite heat 3.6KΩ
R5	resistor-nite cool 1.2KΩ
RT1	sensor-discharge
RT2	sensor-remote (optional)
TB1	block-terminal (low volt)

KEY	DESCRIPTION
A6	control-enthalpy (W7459C)
A7	sensor-enthalpy
B7	motor-damper
J26	jack-enthalpy
J28	jack-W7400
P4	plug-economizer
P26	plug-enthalpy
S13	thermostat-discharge air

- Thermostat Footnotes**
- ▲ REMOVE WIRE K FROM WIRE 4. FASTEN WIRE K TO WIRE 6.
 - ▲ INSERT J19 FOR GCS OR CHA UNITS
 - ▲ TO INSTALL W973 MODULE, DISCONNECT P16 FROM J16 (IN UNIT CONTROL BOX) CONNECT J17 TO P16, AND P17 TO J16.
 - ▲ J3 MAXIMUM LOAD 20VA 24VAC CLASS II

LENNOX Industries Inc. WIRING DIAGRAM 9/88

ACCESS-COMBINATION UNITS-ROOFTOP THERMOSTAT FOR GCS, CHA11 & 16 SERIES UNITS WITH W973 AND WARM UP KIT THERMOSTAT SECTION-C14-1

Supersedes Form No. _____ New Form No. _____

Litho U.S.A.

- Economizer Footnotes**
- ▲ OPTIONAL-SECOND A7 INSTALLED IN RETURN AIR PROVIDES DIFFERENTIAL ENTHALPY CONTROL
 - ▲ FACTORY INSTALLED 620 OHM, 1 WATT, 5% RESISTOR. REMOVE WHEN SECOND A7 SENSOR IS INSTALLED TO PROVIDE DIFFERENTIAL ENTHALPY CONTROL

LENNOX Industries Inc. WIRING DIAGRAM 4/89

ACCESS-COMBINATION UNITS-ROOFTOP REMD16 SERIES EMDH16 SERIES (3 POSITION) ECONOMIZER-SECTION D8

Supersedes Form No. _____ New Form No. _____

Litho U.S.A.

C14-1 DIAGRAM WITH D8 DIAGRAM

Honeywell W973 Control System and T7067 Thermostat with Three-position Economizer and Warm-Up

6-C14-1 Section with D8 Section

The Honeywell W973 control, when added to the GCS16 system, allows the use of electronic "ramping" thermostat, discharge temperature sensors, return air temperature sensors and/or remote thermostats and transmitters. The W973 control system is designed for use with Honeywell T7067 electronic ramping thermostat and Honeywell Q667 subbase. An interconnecting W973 relay kit must be used to adapt the W973 to the GCS16. By adding an REMD16 or EMDH16 economizer, outdoor air can be used for cooling when conditions are suitable. Warm-up kit holds outdoor air dampers closed during morning warm-up after night setback.

NOTE - Use of the Honeywell W973 controller with the GCS16 requires use of the W973 relay kit and CMC3-1 time clock. This arrangement is designed for use with Honeywell T7067 electronic ramping thermostat and Honeywell Q667 subbase or equivalents. A remote setpoint transmitter with either a return air temperature sensor or a room temperature sensor may be used in place of the room thermostat. None of the thermostat/sensor combinations affect the following operation sequence.

NOTE - In order to understand how these optional controls affect the operation of the GCS16, you must first understand how all GCS16 components work. Refer to the operation sequence for basic unit operation.

The W973 plugs in to the GCS16 inside the control make-up area of the GCS16 blower compartment (see figure 98). Jack J17 connects to unit plug P16. Then plug P17 connects to jack J16. Jumper plug J19 supplied with the W973 must be connected to plug P19 on the W973. Jumper plug J12 also supplied with the W973 is not used with GCS16 series units and may be discarded.

The W973 relay kit mounts inside the control make-up area of the GCS16 blower compartment next to the W973. No wiring is required. GCS16 jumper plug P3 is removed and discarded. Warm-up kit harness plug P6 connects directly into GCS16 jack J3 in the blower compartment.

The warm-up kit mounts next to the W973 relay kit as shown in figure 99. Wiring pigtailed must be connected as shown in the wiring diagram on the adjacent page. Otherwise, all other connections are made using jackplugs. Warm-up kit harness plug P8 connects directly into jack J6 of the W973 relay kit. Economizer plug P4 plugs in to jack J8 of the warm-up kit.

WARNING - CONNECT ONLY RELAY KITS DESIGNED FOR THIS CONTROL SYSTEM. RELAY KITS DESIGNED FOR OTHER CONTROL SYSTEMS ARE NOT COMPATIBLE AND CONTROL DAMAGE OR FAILURE WILL RESULT. FOR EXAMPLE, A W7400 RELAY KIT MUST NEVER BE CONNECTED TO A W973 CONTROL SYSTEM.

WARNING - RELAY KITS MUST BE CONNECTED IN THE ORDER THEY APPEAR ON THE UNIT CONTROL WIRING DIAGRAM ON THE ADJACENT PAGE.

Operation Sequence:

- 1-Room temperature is controlled by a thermistor located in A2 (T7067A) thermostat or remote A2 (T7067B) transmitter (RT2). As room temperature changes, thermistor resistance also changes. If room temperature goes up, thermistor resistance goes down. If room temperature goes down, thermistor resistance goes up. The thermistor allows 2.5V/F° (1.4V/C°). When the cooling setpoint is crossed, the T7067 begins transmitting a cooling ramp from terminal 4 through TB1-4 to terminal 4 of A1. As room temperature increases, the cooling ramp increases from 1 to 16 VDC. When the heating setpoint is crossed, the T7067 begins transmitting a heating ramp from terminal 5 through TB1-5 to terminal 5 of A1. As room temperature increases, the cooling ramp increases from 1 to 16 VDC.
- 2- Generally, A1 cooling contacts C1 close when voltage input to A1 terminal 4 reaches 4VDC. C2 cooling contacts close when voltage input to A1 terminal 4 increases to 5 VDC. A1 heating contacts H1 close when voltage input to A1 terminal 5 reaches 4 VDC and H2 contacts close when the voltage ramp increases to 5 VDC.
- 3- To provide anticipation, discharge sensor RT1 modifies the voltage that A1 receives at terminals 4 & 5. If discharge temperature goes up, RT1 resistance goes down. For every 25°F change in discharge temperature, A1 will offset the setpoint 1°F. As a result, RT1 may require a higher or lower voltage input to A1 terminals 4 or 5 before closing C1, C2, H1 or H2.

Day Operation (Occupied Period):

- 4- Time clock CMC3-1 contacts open. Relay K38 in relay kit de-energizes.
- 5- Contacts K38-1 open, removing setback resistor R4 from the circuit. Contacts K38-2 open, removing setup resistor R5 from the circuit. Contacts K38-3 close, control of blower B3 is shifted to A2 terminal 10. During day operation when contacts K38-3 are closed, blower B3 is controlled by A2 terminal 10 and can operate in ON or AUTO modes.
- 6- Power is supplied to the economizer continuously through blower relay K3-2. Contacts K41-3 control economizer operation. During blower operation, outdoor air dampers open to mid (minimum) position when 24V is applied between damper motor terminals X and T.
- 7- Initial heat demand (voltage ramp from A2 terminal 5) closes H1. First stage heat and relay K40 energize.
- 8- Contacts K40-1 open to lock out the economizer for the first heating demand.
- 9- Increased heating demand (increased voltage from A2 terminal 5) closes H2 (not used in this application).
- 10- When the first heating demand is satisfied, the heating section of the GCS16 and relay K40 are de-energized.
- 11- Contacts K40-1 close and power reaches time delay DL7. DL7 begins a 30-second count before closing.
- 12- If a second heat demand reaches relay K40 within 30 seconds, K40-1 opens, time delay DL7 resets and the economizer locks out (warm-up continues) during the second call for heat.

continued on next page

C14-1 DIAGRAM WITH D8 DIAGRAM continued

- 13- If a second demand does not reach relay K40 within 30 seconds, K40-1 remains closed and time delay DL7 closes at the end of 30 seconds.
- 14- When time delay DL7 closes, relay K41 is energized.
- 15- Contacts K41-1 close to lock-in economizer. The economizer remains locked-in until contacts K42-1 open (at night or during unoccupied periods).
Contacts K41-2 open (not used in this application).
Contacts K41-3 close to supply power to the economizer.
Contacts K41-4 open (not used in this application).

Enthalpy Low:

- 16- Initial cool demand (voltage ramp from A2 terminal4) closes C1.
- 17- Enthalpy control A6 has determined that outside air can be used for cooling and has switched internal 1K and 2K internally.
- 18- Cooling demand is routed through enthalpy control terminal 6 and through discharge air thermostat S13 to enthalpy control terminal D and damper motor terminal D. Simultaneously, cooling demand energizes relay K37.
- 19- When 24VAC is applied across terminals D and T of damper motor, the damper motor energizes and outdoor dampers open fully. First stage cooling is provided by outdoor air. Outdoor dampers drive full closed anytime blower B3 is not operating.
- 20- Contacts K37-1 close to energize blower on cooling speed.

2nd stage cool:

- 21- Additional cooling demand (voltage ramp from A2 terminal4) closes C2.
- 22- Demand is routed from A1 terminal C2 through enthalpy control terminals 3 and 5 to energize the compressor and relay K55. The compressor provides all additional cooling demand.
- 23- Contacts K55-1 switch to energize relay K37. Contacts K37-1 close to energize blower on cooling speed (no affect).

Enthalpy High (outside air cannot be used for cooling):

- 24- Enthalpy control internal relays switch to close circuit 1k terminals 1 and 2 (1 & 6 open) and 2K terminals 3 and 4 (3 & 5 open).
- 25- Cooling demand is sent from A1 terminal C1 through enthalpy control terminals 1 and 2 and through enthalpy control terminal 5 to energize the compressor, relays K37 and K55. The compressor handles all cooling demand.
- 26- Contacts K55-1 switch to energize relay K37. Contacts K37-1 close to energize blower on cooling speed (no affect).
- 27- Additional cooling demand (voltage ramp from A2 terminal 4) closes C2 (not used in this application).

Night Setback (optional field installed)

- 28- Optional field installed time clock and night relay K11 must be connected for night setback operation.
- 29- Blower B3 operates only during a heating demand controlled by heat relay K25 in the unit. Outdoor dampers are held closed by relay K41.
- 30- When clock contacts close, relays K11 (not shown), K38 and K42 all energize.

- 31- K42-1 opens to de-energize relay K41.
- 32- K41-3 opens to drive dampers closed.
- 33- Contacts K38-1 close to energize setback resistor R4.
Contacts K38-2 close to energize setup resistor R5.
Contacts K38-3 open to energize blower B3 on demand only.
During night operation when contacts K38-3 are open. blower B3 operates only on demand powered through relays K25 (for heat) or K37 (for cool). Outdoor air dampers are held closed by contacts K11-2 remaining open.
- 34- A1 terminal 1 feeds 20VDC at all times to A2 terminal 1 and contacts K38-1 and K38-2 (source of voltage for resistors).
- 35- When heating demand is present during unoccupied periods, 20VDC feeds through K38-1 and R4. R4 alters the voltage. A2 terminal 6 receives that altered voltage and uses it to shift the unoccupied setpoint. R4's value, 3.6K ohms, shifts the unoccupied setpoint down 10°F. For example, if heat lever of A2 is set at 75°F, the unoccupied setpoint for first stage operation is 65°F.
- 36- When cooling demand is present during unoccupied periods, 20VDC feeds through K38-2 and R5. R5 alters the voltage. A2 terminal 8 receives that altered voltage and uses it to shift the unoccupied setpoint. R5's value, 1.2K ohms, locks out cooling in unoccupied mode.

Morning Warm-Up:

- 37- Shortly before the building is to be occupied, time clock CMC3-1 contacts open.
- 38- Relays K38, K42 and K11 (not shown) disengage.
- 39- Contacts K42-1 open. Contacts K11-2 close to allow outdoor dampers to open. Note that dampers remain closed until relays K3 and K41 are energized.
- 40- Since contacts K40-1 are normally closed and contacts K42-1 have just switched closed, timer DL7 is energized. Timer DL7 is normally open and closes 30 sec. after being energized.
- 41- If heat demand H1 reaches relay K40 before delay DL7 closes, contacts K40-1 open, delay DL7 loses power and resets and the economizer locks out for the first heat demand by relay K41 (contacts K41-3 remain open). If heat demand H1 reaches relay K40 after delay DL7 closes, relay K41 energizes and the economizer locks in for the day until night setback.
- 42- When first heat demand is satisfied, relay K40 disengages and relay contacts K40-1 close. Relay contacts K42-1 are already closed (clock contacts open). Time delay DL7 begins 30 sec. count. If a second heat demand H1 reaches relay K42 within 30 seconds, delay DL7 loses power, reset and steps 41 and 42 repeat. If a second heat demand H1 does not reach relay K42 within 30 sec., time delay DL7 contacts close and relay K41 energizes.
- 43- When relay K41 energizes, the economizer is allowed to operate normally, controlled by relay K3:
Contacts K41-1 close to lock in economizer operation until night setback.
Contacts K41-2 open (not used).
Contacts K41-3 close to allow power to the economizer.
Contacts K41-4 close (not used).
- 44- Once energized, relay K41 locks in and the economizer operates until relay K42 is energized by night setback (contacts K42-1 open to disengage relay K41).

C14-1 diagram with D5 diagram W973 Control with modulating economizer and warm-up

24V POWER

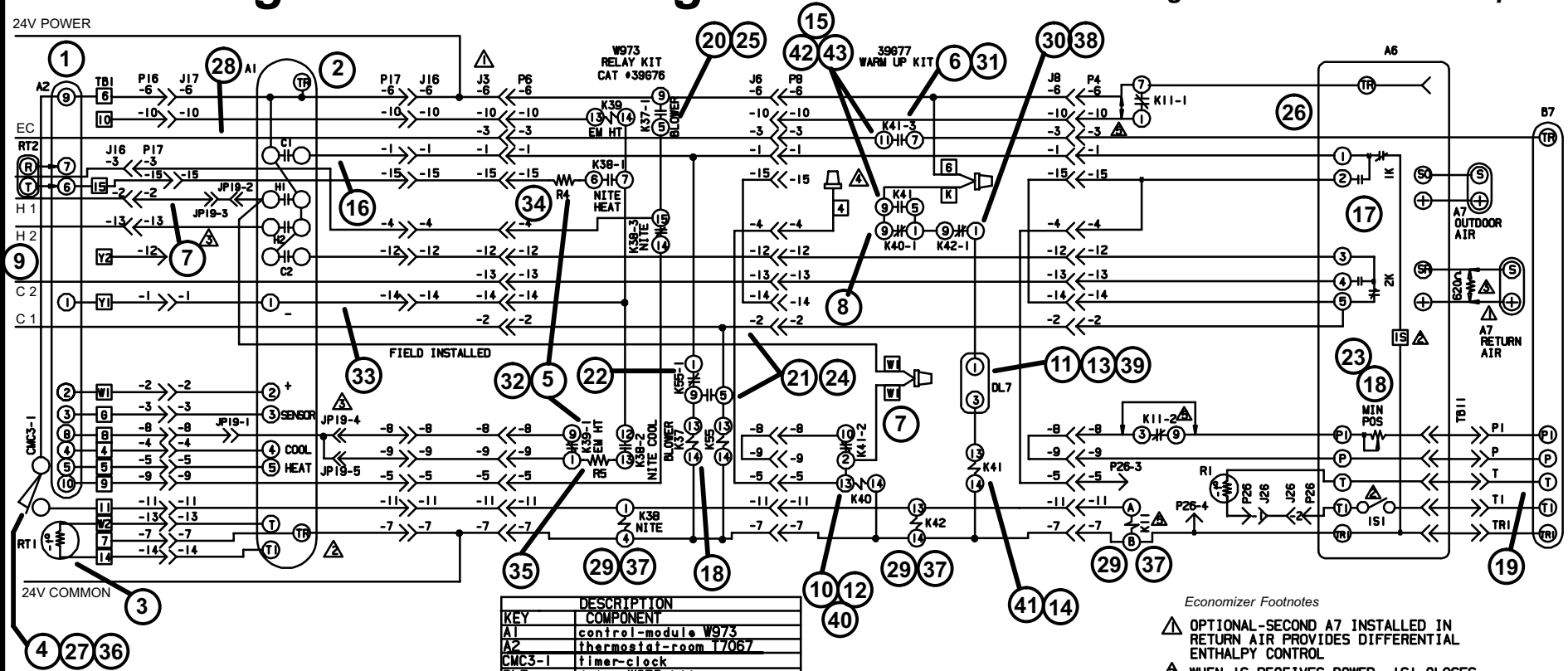

Page 132

- Thermostat Footnotes**
- ⚠ REMOVE WIRE K FROM WIRE 4. FASTEN WIRE K TO WIRE 6.
 - ⚠ INSERT J19 FOR GCS OR CHA UNITS
 - ⚠ TO INSTALL W973 MODULE, DISCONNECT P16 FROM J16 (IN UNIT CONTROL BOX) CONNECT J17 TO P16, AND P17 TO J16.
 - ⚠ J3 MAXIMUM LOAD 20VA 24VAC CLASS II

- Economizer Footnotes**
- ⚠ OPTIONAL-SECOND A7 INSTALLED IN RETURN AIR PROVIDES DIFFERENTIAL ENTHALPY CONTROL
 - ⚠ WHEN IS RECEIVES POWER, ISI CLOSSES.
 - ⚠ FACTORY INSTALLED 620 OHM, 1 WATT, 5% RESISTOR. REMOVE WHEN SECOND A7 SENSOR IS INSTALLED TO PROVIDE DIFFERENTIAL ENTHALPY CONTROL
 - ⚠ WHEN W7400 CONTROL IS USED, REMOVE J26 JUMPER AND INSTALL J28. J28 AND K7 RELAY ARE PART OF W7400 KIT (74811)
 - ⚠ K11 NITE RELAY MAY NOT BE PART OF ECONOMIZERS ON UNITS BELOW 7.5T CAPACITY

KEY	DESCRIPTION
A1	control-module W973
A2	thermostat-room T7067
CMC3-1	timer-clock
DL7	delay-W973 kit
J3	jack-economizer
J6	jack-W973 kit
J8	jack-warm up kit
J16	jack-unit
J17	jack-module
J19	jack-plug select CHA, GCS
K37-1	relay-blower W973 kit
K38-1,2,3	relay-emerg ht W973 kit
K39-1	relay-nite W973 kit
K40-1	relay-warm up kit-ht latch
K41-1,2,3	relay-warm up kit-latch

KEY	DESCRIPTION
K42-1	relay-warm up kit-clock
K55-1	relay-blower LVAV
P6	plug-W973 relay kit
P8	plug-warm up kit
P16	plug-unit
P17	plug-module
R4	resistor-nite heat 3.6K Ω
R5	resistor-nite cool 1.2K Ω
RT1	sensor-discharge
RT2	sensor-remote (optional)
TB1	block-terminal (low volt)

KEY	DESCRIPTION
A6	control-enthalpy W7459A
A7	sensor-enthalpy
B7	motor-damper
J26	jack-enthalpy
J28	jack-W7400
K7-1	relay-W7400
K11-1,2	relay-nite setback
P4	plug-economizer
P26	plug-enthalpy
R1	sensor-supply air
TB11	strip-terminal

LENNOX[®] Industries Inc. WIRING DIAGRAM 9/88

ACCESS-COMBINATION UNITS-ROOFTOP

THERMOSTAT FOR
GCS, CHA11 & 16 SERIES UNITS
WITH W973 AND WARM UP KIT

THERMOSTAT SECTION-C14-1

Supersedes Form No. _____ New Form No. _____

Litho U.S.A.

LENNOX[®] Industries Inc. WIRING DIAGRAM 4/89

ACCESS-COMBINATION UNITS-ROOFTOP

REMD16M EMDH16M
REMD11M EMD17-95/135
(MODULATING ECONOMIZER)

ECONOMIZER SECTION D5

Supersedes Form No. _____ New Form No. _____

Litho U.S.A.

C14-1 DIAGRAM WITH D5 DIAGRAM

Honeywell W973 Control System and T7067 Thermostat with Modulating Economizer and Warm-up

7-C14-1 Section with D5 Section

The Honeywell W973 control, when added to the GCS16 system, allows the use of electronic ramping thermostat, discharge temperature sensors, return air temperature sensors and/or remote thermostats and transmitters. The W973 control system is designed for use with Honeywell T7067 electronic ramping thermostat and Honeywell Q667 subbase. An interconnecting W973 relay kit must be used to adapt the W973 to the GCS16.

NOTE - Use of the Honeywell W973 controller with the GCS16 requires use of the W973 relay kit and CMC3-1 time clock. This arrangement is designed for use with Honeywell T7067 electronic ramping thermostat and Honeywell Q667 subbase or equivalents. A remote setpoint transmitter with either a return air temperature sensor or a room temperature sensor may be used in place of the room thermostat. None of the thermostat/sensor combinations affect the following operation sequence.

NOTE - In order to understand how these optional controls affect the operation of the GCS16, you must first understand how all GCS16 components work. Refer to the operation sequence for basic unit operation.

The W973 plugs in to the GCS16 inside the control make-up area of the GCS16 blower compartment (see figure 98). Jack J17 connects to unit plug P16. Then plug P17 connects to jack J16. Jumper plug J19 supplied with the W973 must be connected to plug P19 on the W973. Jumper plug J12 also supplied with the W973 is not used with GCS16 series units and may be discarded.

The W973 relay kit mounts inside the control make-up area of the GCS16 blower compartment next to the W973. No wiring is required. GCS16 jumper plug P3 is removed and discarded. Warm-up kit harness plug P6 connects directly into GCS16 jack J3 in the blower compartment.

The warm-up kit mounts next to the W973 relay kit as shown in figure 99. Wiring pigtailed must be connected as shown in the wiring diagram on the adjacent page. Otherwise, all other connections are made using jackplugs. Warm-up kit harness plug P8 connects directly into jack J6 of the W973 relay kit. Economizer plug P4 plugs in to jack J8 of the warm-up kit.

WARNING - CONNECT ONLY RELAY KITS DESIGNED FOR THIS CONTROL SYSTEM. RELAY KITS DESIGNED FOR OTHER CONTROL SYSTEMS ARE NOT COMPATIBLE AND CONTROL DAMAGE OR FAILURE WILL RESULT. FOR EXAMPLE, A W7400 RELAY KIT MUST NEVER BE CONNECTED TO A W973 CONTROL SYSTEM.

WARNING - RELAY KITS MUST BE CONNECTED IN THE ORDER THEY APPEAR ON THE UNIT CONTROL WIRING DIAGRAM ON THE ADJACENT PAGE.

Operation Sequence:

1- Room temperature is controlled by a thermistor located in A2 (T7067A) thermostat or remote A2 (T7067B) transmitter (RT2). As room temperature changes, thermistor resistance also changes. If room temperature goes up, thermistor resistance goes down. If room temperature goes down, thermistor resistance goes up. The thermistor allows 2.5V/F° (1.4V/C°).

When the cooling setpoint is crossed, the T7067 begins transmitting a cooling ramp from terminal 4 through TB1-4 to terminal 4 of A1. As room temperature increases, the cooling ramp increases from 1 to 16 VDC.

When the heating setpoint is crossed, the T7067 begins transmitting a heating ramp from terminal 5 through TB1-5 to terminal 5 of A1. As room temperature increases, the cooling ramp increases from 1 to 16 VDC.

- 2- Generally, A1 cooling contacts C1 close when voltage input to A1 terminal 4 reaches 4VDC. C2 cooling contacts close when voltage input to A1 terminal 4 increases to 5 VDC. A1 heating contacts H1 close when voltage input to A1 terminal 5 reaches 4 VDC and H2 contacts close when the voltage ramp increases to 5 VDC.
- 3- To provide anticipation, discharge sensor RT1 modifies the voltage that A1 receives at terminals 4 & 5. If discharge temperature goes up, RT1 resistance goes down. For every 25°F change in discharge temperature, A1 will offset the setpoint 1°F. As a result, RT1 may require a higher or lower voltage input to A1 terminals 4 or 5 before closing C1, C2, H1 or H2.

Day Operation (Occupied Period):

- 4- Time clock CMC3-1 contacts open. Relay K38 in relay kit de-energizes.
- 5- Contacts K38-1 open, removing setback resistor R4 from the circuit. Contacts K38-2 open, removing setup resistor R5 from the circuit. Contacts K38-3 close, control of blower B3 is shifted to A2 terminal 10. During day operation when contacts K38-3 are closed, blower B3 is controlled by A2 terminal 10 and can operate in ON or AUTO modes.
- 6- Power is supplied to the economizer continuously through blower relay K3-2. Contacts K7-1 and K41-3 control economizer operation.
- 7- Initial heat demand (voltage ramp from A2 terminal 5) closes H1. First stage heat and relay K40 energize.
- 8- Contacts K40-1 open to lock out the economizer for the first heating demand.
- 9- Increased heating demand (increased voltage from A2 terminal 5) closes H2 (not used in this application).
- 10- When the first heating demand is satisfied, the heating section of the GCS16 and relay K40 are de-energized.
- 11- Contacts K40-1 close and power reaches time delay DL7. DL7 begins a 30 second count before closing.
- 12- If a second heat demand reaches relay K40 within 30 seconds, K40-1 opens, time delay DL7 resets and the economizer locks out (warm-up continues) during the second call for heat.
- 13- If a second demand does not reach relay K40 within 30 seconds, K40-1 remains closed and time delay DL7 closes at the end of 30 seconds.
- 14- When time delay DL7 closes, relay K41 is energized.
- 15- Contacts K41-1 close to lock-in economizer. The economizer remains locked-in until contacts K42-1 open (at night or during unoccupied periods). Contacts K41-2 open (not used in this application). Contacts K41-3 close to supply power to the economizer. Contacts K41-4 open (not used in this application).

continued on next page

C14-1 DIAGRAM WITH D5 DIAGRAM

Enthalpy Low (outside air can be used for cooling):

- 16- Initial cool demand (voltage ramp from A2 terminal4) closes C1.
- 17- Enthalpy control A6 has determined that outside air can be used for cooling and has switched 1K and 2K internally.
- 18- Cooling demand is routed through enthalpy control to energize internal relay 1S. Internal contacts 1S1 close to complete a circuit through damper motor terminals T and T1. Simultaneously, cooling demand energizes relay K37.
- 19- When a voltage is applied across terminals T and T1 of damper motor, the damper motor energizes and outdoor dampers open. Supply air sensor R1 varies the voltage across T and T1 and the outdoor air dampers adjust accordingly. First stage cooling is provided by outdoor air.
- 20- Contacts K37-1 close to energize blower on cooling speed.
- 21- Additional cooling demand closes C2. Demand is routed through enthalpy control terminals 3 and 5 to energize the compressor and relay K55. The compressor provides all additional cooling.
- 22- Contacts K55-1 switch to energize relay K37. Contacts K37-1 close to energize blower on cooling speed (no affect).

Enthalpy High (outside air cannot be used for cooling):

- 23- Enthalpy control internal relays 1K and 2K switch. Internal relay 1S is de-energized and 1S1 opens. Outdoor air dampers close to minimum position during blower operation.
- 24- Cooling demand is sent from A1 terminal C1 through enthalpy control terminals 1 and 2 and through enthalpy control terminal 5 to energize the compressor and relays K37 and K55. The compressor handles all cooling demand.
- 25- Contacts K37-1 close to energize blower on cooling speed. Simultaneously, contacts K55-1 switch (no affect). Blower is energized on cooling speed.
- 26- Blower demand energizes relay K3 in unit. Contacts K3-1 close to energize the blower and contacts K3-2 close to energize the economizer. When 24VAC is applied between damper motor terminal TR and TR1, outdoor dampers open to minimum position.

Night Setback (optional field installed)

- 27- Optional field installed time clock, night thermostat S12 and night relay kit K11 must be connected for night setback operation.
- 28- Blower B3 operates only during a heating demand.
- 29- When clock contacts close, relays K11, K38 and K42 all energize.
- 30- K42-1 opens to de-energize relay K41.
- 31- K41-3 opens to drive dampers closed.

- 32- Contacts K38-1 close to energize setback resistor R4. Contacts K38-2 close to energize set-up resistor R5. Contacts K38-3 open to energize blower B3 on demand only. During night operation when contacts K38-3 are open, blower B3 operates only on demand powered through relays K25 (for heat) or K37 (for cool). Outdoor air dampers are held closed by contacts K11-2 which remain open.
- 33- A1 terminal 1 feeds 20VDC at all times to A2 terminal 1 and contacts K38-1 and K38-2.
- 34- When heating demand is present during unoccupied periods, 20VDC feeds through K38-1 and R4. R4 alters the voltage. A2 terminal 6 receives altered voltage and uses it to shift the unoccupied setpoint. R4's value, 3.6K ohms, shifts the unoccupied setpoint down 10°F. For example, if heat lever of A2 is set at 75°F, the unoccupied setpoint for first stage operation is 65°F.
- 35- When cooling demand is present during unoccupied periods, 20VDC feeds through K38-2 and R5. R5 alters the voltage. A2 terminal 8 receives that altered voltage and uses it to shift the unoccupied setpoint. R5's value, 1.2K ohms, locks out cooling in unoccupied mode.

Morning Warm-Up:

- 36- Shortly before the building is to be occupied, time clock CMC3-1 contacts open.
- 37- Relays K38, K42 and K11 disengage.
- 38- Contacts K42-1 open. Contacts K11-2 close to allow outdoor dampers to open. Note that dampers remain closed until relays K3 and K41 are energized.
- 39- Since contacts K40-1 are normally closed and contacts K42-1 have just switched closed, timer DL7 is energized. Timer DL7 is normally open and closes 30 seconds after being energized.
- 40- If heat demand H1 reaches relay K40 before delay DL7 closes, contacts K40-1 open, delay DL7 loses power and resets and the economizer locks out for the first heat demand by relay K41 (contacts K41-3 remain open). If heat demand H1 reaches relay K40 after delay DL7 closes, relay K41 energizes and the economizer locks in for the day until night setback.
- 41- When first heat demand is satisfied, relay K40 disengages and relay contacts K40-1 close. Relay contacts K42-1 are already closed (clock contacts open). Time delay DL7 begins 30 second count. If a second heat demand H1 reaches relay K42 within 30 seconds, delay DL7 loses power, resets and steps 41 and 42 repeat. If a second heat demand H1 does not reach relay K42 within 30 seconds, time delay DL7 contacts close and relay K41 energizes.
- 42- When relay K41 energizes, the economizer operates normally, controlled by relay K3: Contacts K41-1 close to lock in economizer operation until night setback. Contacts K41-2 open (not used). Contacts K41-3 close to allow power to the economizer. Contacts K41-4 close (not used).
- 43- Once energized, relay K41 locks in and the economizer operates until relay K42 is energized by night setback (contacts K42-1 open to disengage relay K41).