

INSTALLATION INSTRUCTIONS

⚠ WARNING

Improper installation, adjustment, alteration, service or maintenance can cause property damage, personal injury or loss of life. Installation and service must be performed by a qualified installer, service agency or the gas supplier

Table Of Contents

Dimensions	1
Parts Arrangements	2
Shipping and Packing List	3
General	3
Requirements	3
Unit Support	3
Duct Connections	4
Rigging Unit For Lifting	4
Condensate Drains	4
Gas Piping	5
Pressure Test Gas Piping	5
High Altitude Derate	6
Factory-Installed Options	6

LGC090S, LCC090S	(7.5 Ton)
LGA090H, LCA090H	(7.5 Ton)
LGA102H, LCA102H	(8.5 Ton)
LGC102S, LCC102S	(8.5 Ton)
LGA120H, LCA120H	(10 Ton)
LGC120S, LCC120S	(10 Ton)
LGC150S, LCC150S	(12.5 Ton)

L SERIES PACKAGED UNITS
504,785M
6/2003
Supersedes 504,563M

Electrical Connections	7
Blower Operation and Adjustments	9
Cooling Start-Up	13
Gas Heat Start-Up	17
Heating Operation and Adjustments	18
Electric Heat Start-Up	19
Humiditrol® Start-Up and Operation	20
Service	22

RETAIN THESE INSTRUCTIONS FOR FUTURE REFERENCE

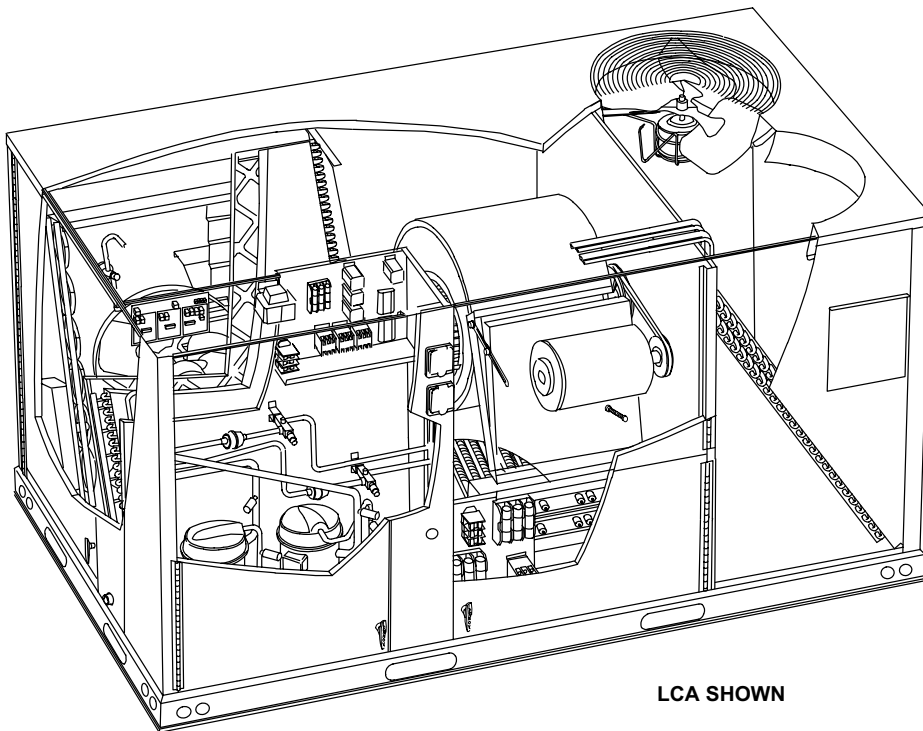

LCA SHOWN



LGA/LGC/LCA/LCC090, 102, 120, & 150 DIMENSIONS - LGA/LGC HEAT SECTION SHOWN

*Reheat coils are factory-installed in Humiditrol units only.

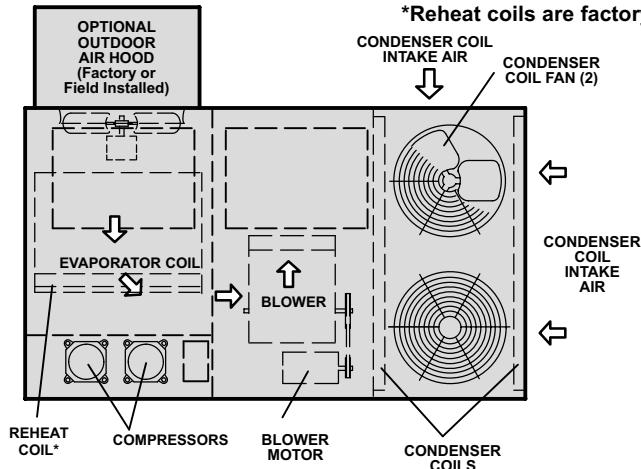

TOP VIEW

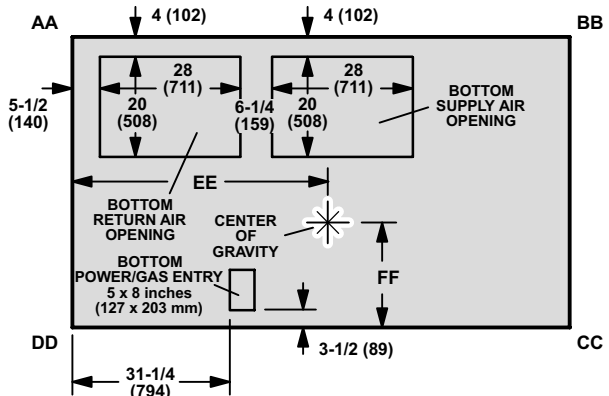

**TOP VIEW
Base Section**

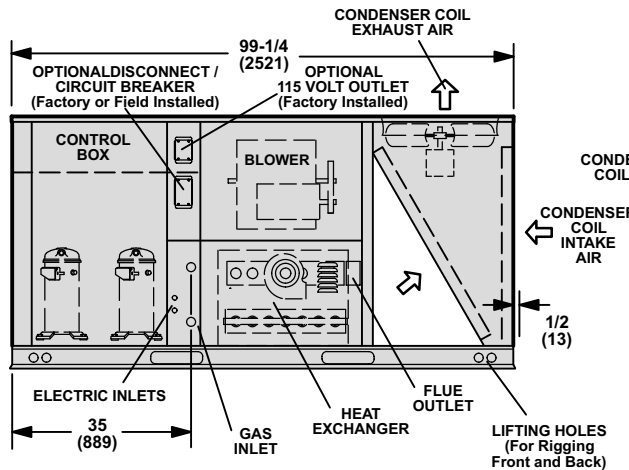

FRONT VIEW

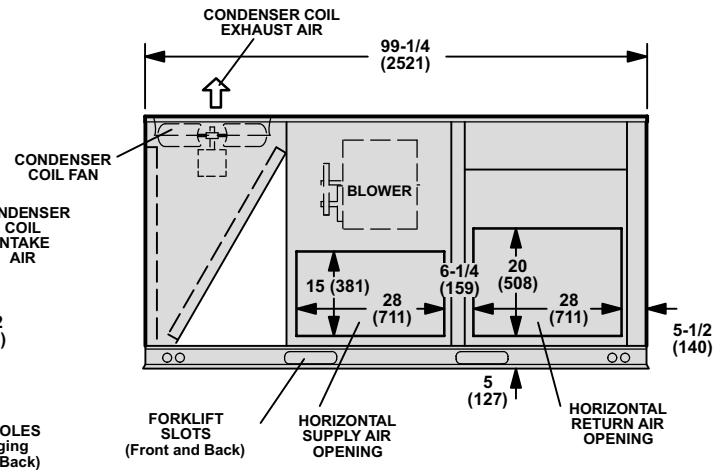

BACK VIEW

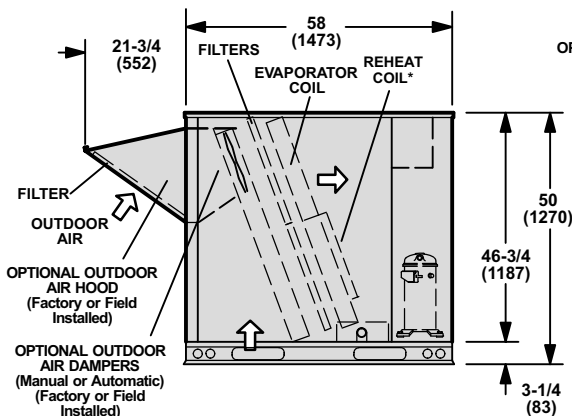

**LEFT SIDE
(Outdoor Air Dampers)**

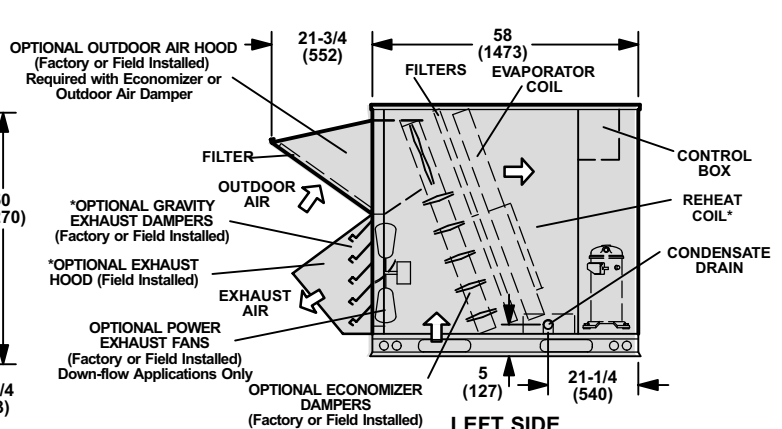

**LEFT SIDE
(Economizer)**

*NOTE — Field Installed in Return Air Duct for Horizontal Applications.

LGA/LGC090, 102, 120, & 150 PARTS ARRANGEMENT

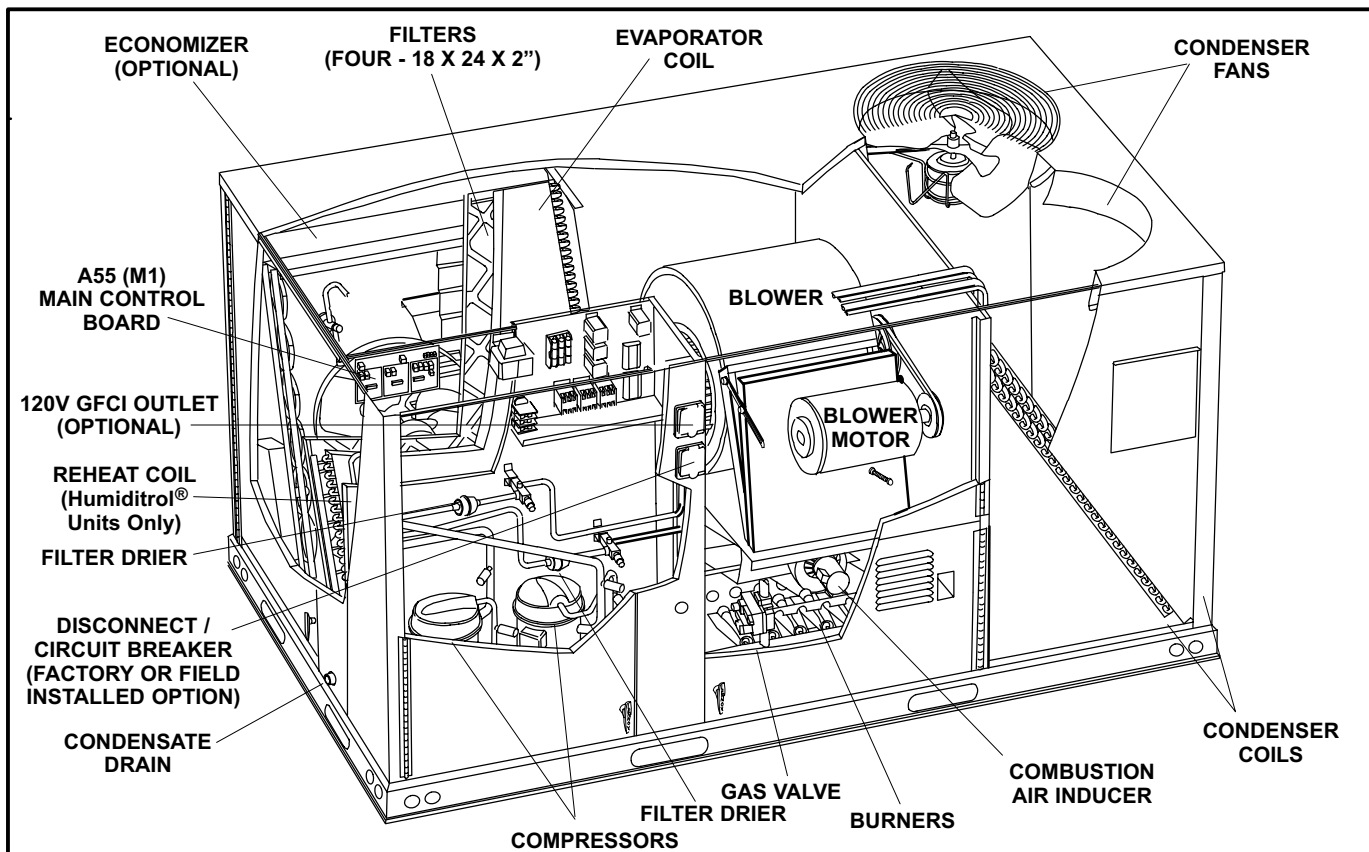

LCA/LCC090, 102, 120, & 150 PARTS ARRANGEMENT

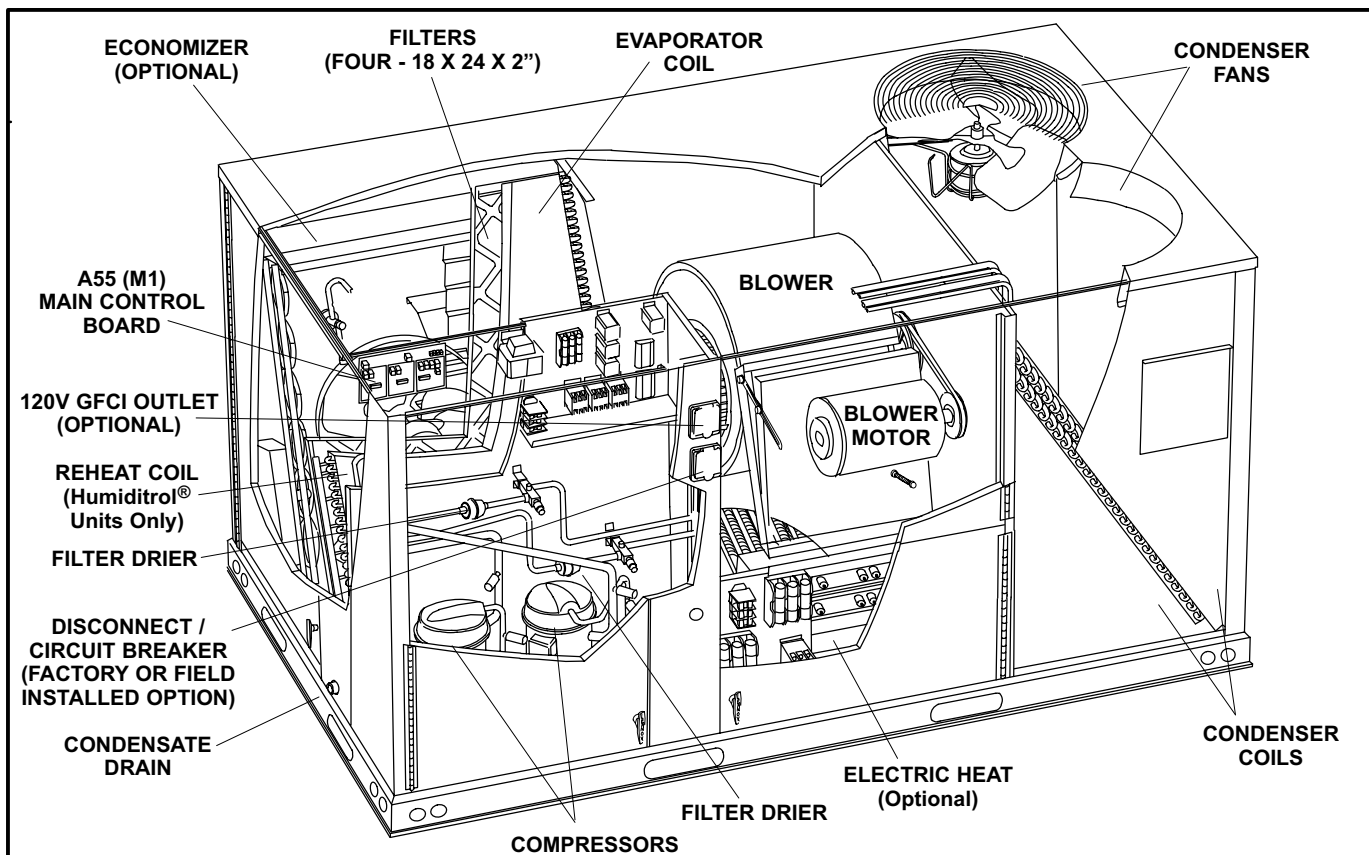

⚠ CAUTION

Danger of sharp metallic edges. Can cause injury. Take care when servicing unit to avoid accidental contact with sharp edges.

Shipping and Packing List

Package 1 of 1 contains:

1- Assembled unit

IMPORTANT - Humiditrol® units require a specific field-provided and installed humidity sensor.

Check unit for shipping damage. Receiving party should contact last carrier immediately if shipping damage is found.

General

These instructions are intended as a general guide and do not supersede local codes in any way. Authorities having jurisdiction should be consulted before installation.

The LGA/LGC090, 102, 120, & 150 gas/electric packaged rooftop unit is available in 130,000 Btuh or 235,000 Btuh heating inputs. The LCA/LCC090, 102, 120 & 150 cooling packaged rooftop unit is the same basic design as the LGA/LGC unit except for the heating section. Optional electric heat is factory- or field-installed in LCA/LCC units. LGA/LGC and LCA/LCC units have identical refrigerant circuits with respective 7-1/2, 8-1/2, 10, and 12-1/2 ton cooling capacities.

In addition to standard heating and cooling, Humiditrol® units provide a dehumidifying mode of operation. Refer to Reheat Operation section.

The LGC/LCC120S unit is available using R410A, an ozone-friendly HFC refrigerant. Refer to the Cooling Start-Up section for precautions when installing unit.

Requirements

NOTE - These units must not be used as a "construction heater" at any time during any phase of construction. Very low return air temperatures, harmful vapors, and misplacement of the filters will damage the unit and its efficiency.

⚠ IMPORTANT

The Clean Air Act of 1990 bans the intentional venting of refrigerant (CFC's and HCFC's) as of July 1, 1992. Approved methods of recovery, recycling or reclaiming must be followed. Fines and/or incarceration may be levied for non-compliance.

⚠ WARNING



Electric shock hazard and danger of explosion. Can cause injury, death or product or property damage. Turn off gas and electrical power to unit before performing any maintenance or servicing operations on the unit. Follow lighting instructions attached to unit when putting unit back into operation and after service or maintenance.

See figure 1 for unit clearances.

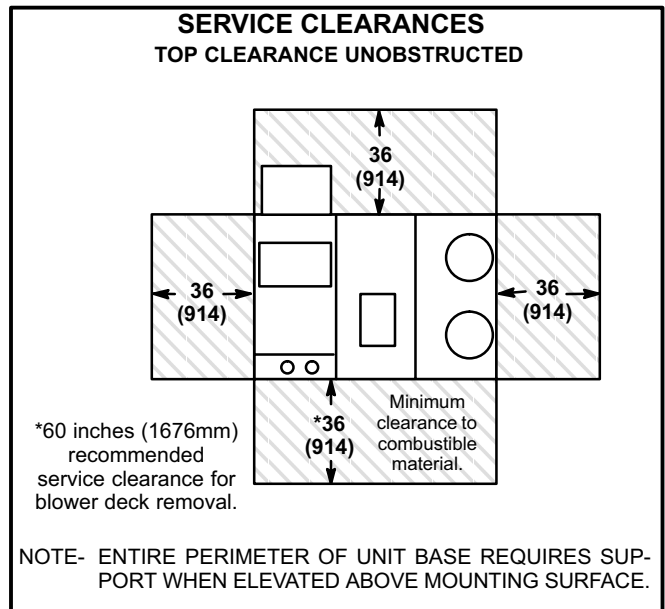

FIGURE 1

Unit Support

In downflow discharge installations, install the unit on a non-combustible surface only. Unit may be installed on combustible surfaces when used in horizontal discharge applications or in downflow discharge applications when installed on an LARMF10/15 roof mounting frame.

NOTE - Securely fasten roof frame to roof per local codes.

A-Downflow Discharge Application

Roof Mounting with LARMF10/15

- 1- The LARMF roof mounting frame must be installed, flashed and sealed in accordance with the instructions provided with the frame.
- 2- The LARMF roof mounting frame should be square and level to 1/16" per linear foot (5mm per linear meter) in any direction.
- 3- Duct must be attached to the roof mounting frame and not to the unit; supply and return plenums must be installed before setting the unit.

Installer's Roof Mounting Frame

Many types of roof frames can be used to install the unit depending upon different roof structures. Items to keep in mind when using the building frame or supports are:

- 1- The base is fully enclosed and insulated, so an enclosed frame is not required.
- 2- The frames or supports must be constructed with non-combustible materials and should be square and level to 1/16" per linear foot (5mm per linear meter) in any direction.
- 3- Frame or supports must be high enough to prevent any form of moisture from entering unit. Recommended minimum frame height is 14" (356mm).
- 4- Duct must be attached to the roof mounting frame and not to the unit. Supply and return plenums must be installed before setting the unit.
- 5- Units require support along all four sides of unit base. Supports must be constructed of steel or suitably treated wood materials.

NOTE-When installing a unit on a combustible surface for downflow discharge applications, an LARMF10/15 roof mounting frame is required.

B-Horizontal Discharge Applications

- 1- Units installed in horizontal airflow applications must use a horizontal conversion kit (56K53).
- 2- Specified installation clearances must be maintained when installing units. Refer to figure 1.
- 3- Top of support slab should be approximately 4" (102mm) above the finished grade and located so no run-off water from higher ground can collect around the unit.
- 4- Units require support along all four sides of unit base. Supports must be constructed of steel or suitably treated wood materials.

Duct Connection

All exterior ducts, joints and openings in roof or building walls must be insulated and weather-proofed with flashing and sealing compounds in accordance with applicable codes. Any duct passing through an unconditioned space must be insulated.

⚠ CAUTION

In downflow applications, do not drill or punch holes in base of unit. Leaking in roof may occur if unit base is punctured.

Rigging Unit For Lifting

Rig unit for lifting by attaching four cables to holes in unit base rail. See figure 2.

- 1- Detach wooden base protection before rigging.
- 2- Connect rigging to the unit base using both holes in each corner.
- 3- All panels must be in place for rigging.
- 4- Place field-provided H-style pick in place just above top edge of unit. Frame must be of adequate strength and length. (H-style pick prevents damage to top of unit.)

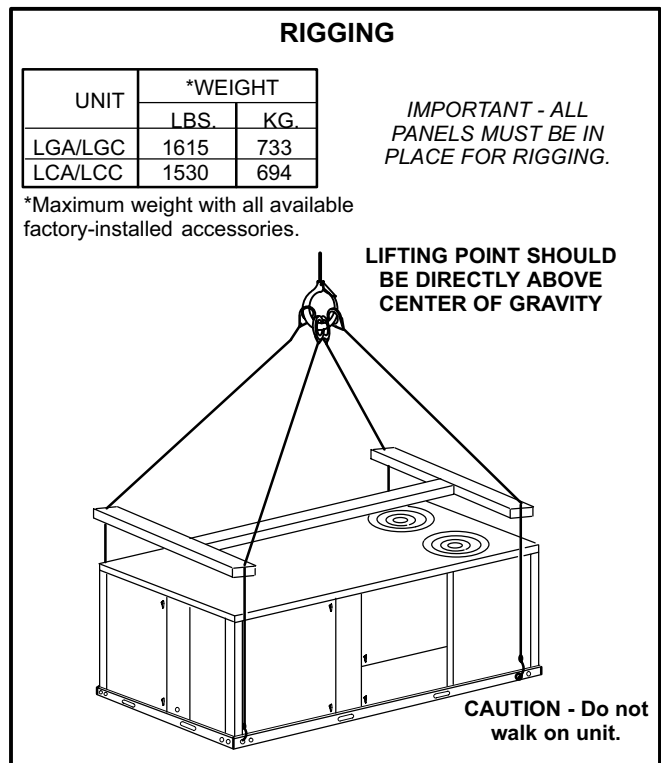

FIGURE 2

Condensate Drains

Make drain connection to the 1" N.P.T. drain coupling provided on unit. A trap must be installed between drain connection and an open vent for proper condensate removal. See figure 3. It is sometimes acceptable to drain condensate onto the roof or grade; however, a tee should be fitted to the trap to direct condensate downward. The condensate line must be vented. Check local codes concerning condensate disposal. Refer to pages 1 and 2 for condensate drain location.

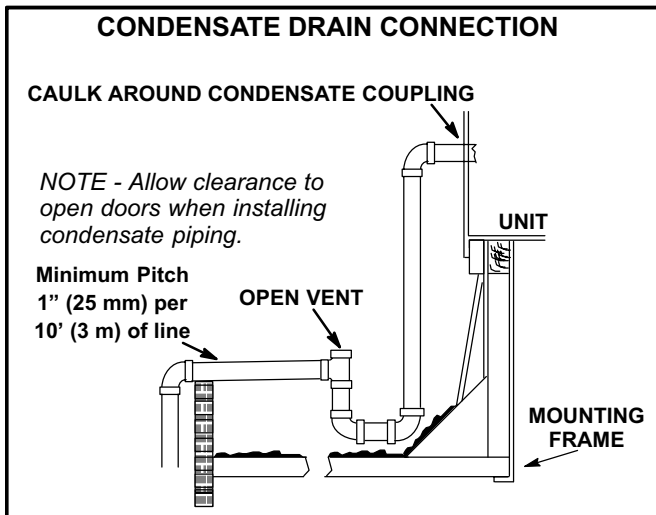

FIGURE 3

Connect Gas Piping (LGA/LGC Units)

Before connecting piping, check with gas company or authorities having jurisdiction for local code requirements. When installing gas supply piping, length of run from gas meter must be considered in determining pipe size for 0.5" w.c. (.12kPa) maximum pressure drop. Do not use supply pipe smaller than unit gas connection. For natural gas units, operating pressure at the unit gas connection must be a minimum of 4.7" w.c. (1.17kPa) and a maximum of 10.5" (2.60kPa) w.c. For LP/propane gas units, operating pressure at the unit gas connection must be a minimum of 11" w.c. (2.74kPa) and a maximum of 13.5" w.c. (3.36kPa).

When making piping connections a drip leg should be installed on vertical pipe runs to serve as a trap for sediment or condensate. A 1/8" N.P.T. plugged tap is located on gas valve for test gauge connection. Refer to Heating Start-Up section for tap location. Install a ground joint union between the gas control manifold and the main manual shut-off valve. See figure 4 for gas supply piping entering outside the unit. Figure 5 shows complete bottom gas entry piping.

Compounds used on threaded joints of gas piping shall be resistant to the action of liquified petroleum gases.

Pressure Test Gas Piping (LGA/LGC Units)

When pressure testing gas lines, the gas valve must be disconnected and isolated. Gas valves can be damaged if subjected to more than 0.5 psig (3.48kPa). See figure 6.

NOTE-Codes may require that manual main shut-off valve and union (furnished by installer) be installed in gas line external to unit. Union must be of the ground joint type.

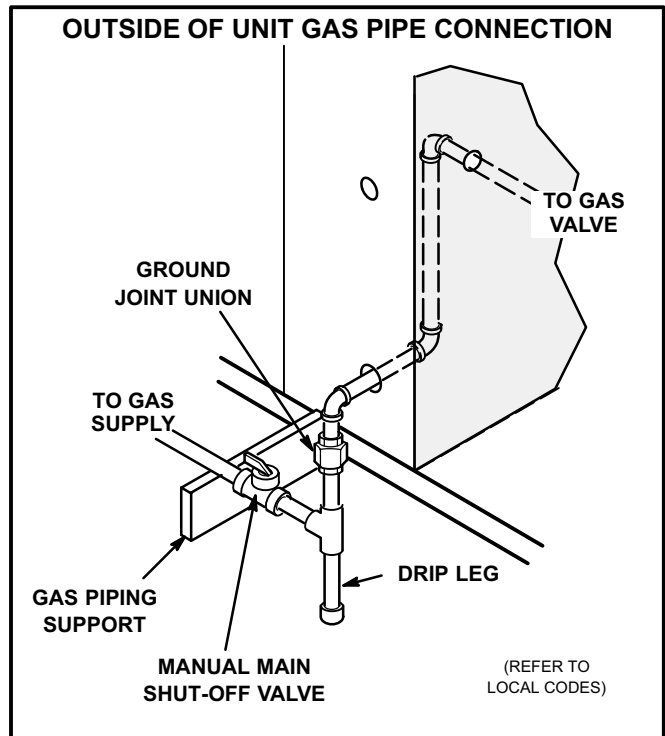

FIGURE 4

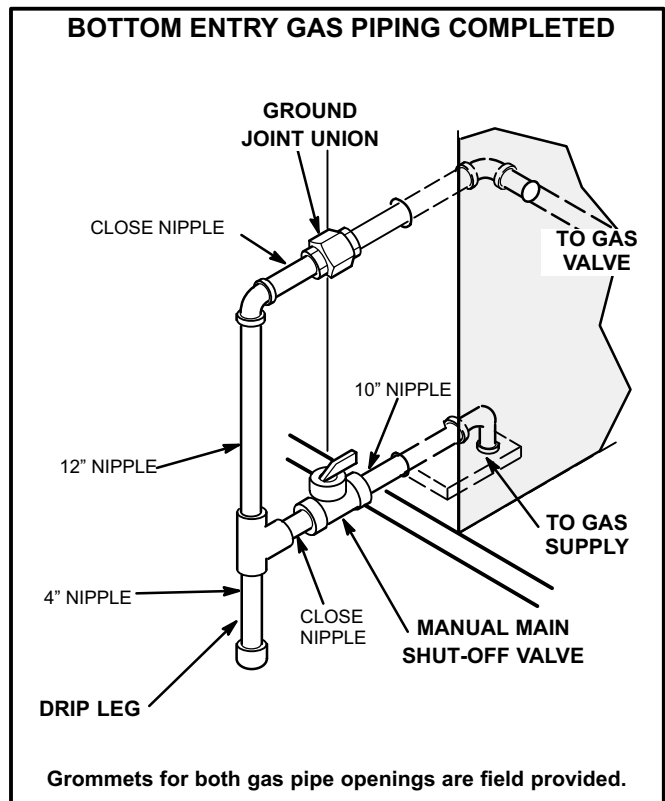

FIGURE 5

After all connections have been made, check all piping connections for gas leaks. Also check existing gas connections up to the gas valve; loosening may occur during installation. Use a soap solution or other preferred means. Do not use matches candles or other sources of ignition to check for gas leaks.

⚠ CAUTION

Some soaps used for leak detection are corrosive to certain metals. Carefully rinse piping thoroughly after leak test has been completed. Do not use matches, candles, flame or other sources of ignition to check for gas leaks.

⚠ WARNING



Danger of explosion. Can cause injury or product or property damage. Do not use matches, candles, flame or other sources of ignition to check for leaks.

NOTE-In case emergency shut down is required, turn off the main manual shut-off valve and disconnect main power to unit. These devices should be properly labeled by the installer.

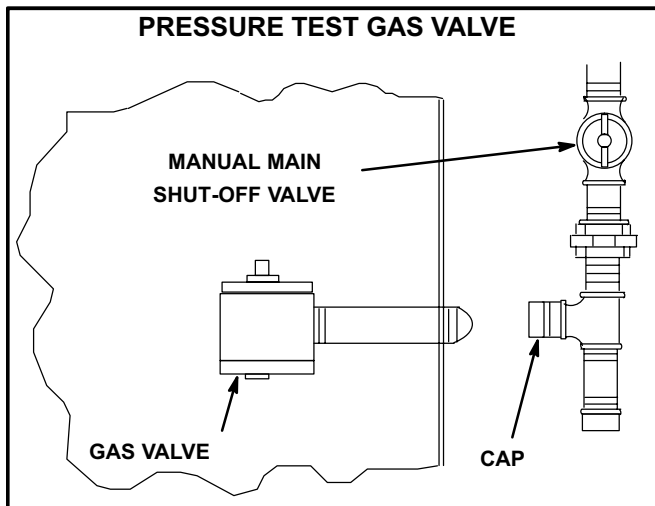

FIGURE 6

High Altitude Derate

Units may be installed at altitudes up to 2000 feet (610 m) above sea level without any modification. At altitudes above 2000 feet (610 m), units must be derated to match the gas manifold pressures shown in table 1.

NOTE - This is the only permissible derate for these units.

TABLE 1

Altitude - ft. (m)	Gas Manifold Pressure in. w.g. (kPa)	
	Natural	LP (Propane)
2001 - 3000 (610 - 915)	3.6 (0.90)	10.2 (2.54)
3001 - 4000 (915 - 1220)	3.5 (0.87)	9.9 (2.46)
4001 - 5000 (1220 - 1525)	3.4 (0.85)	9.6 (2.39)
5001 - 6000 (1525 - 1830)	3.3 (0.82)	9.4 (2.34)
6001 - 7000 (1830 - 2135)	3.2 (0.80)	9.1 (2.26)
7001 - 8000 (2135 - 2440)	3.1 (0.77)	8.8 (2.19)

Factory-Installed Options

A-Economizer

The A56 EM1 economizer board controls economizer operation and provides potentiometers to control minimum damper position and enthalpy control adjustments. The economizer board is positioned on the A55 M1 main control board in the unit control box. See the Integrated Modular Control Guide for economizer operation and adjustments.

B-Intake Hood

The intake hood top panel is secured to the unit. The intake hood sides, filters, and three support brackets are shipped unassembled in the blower compartment. Assemble hood and install as follows:

- 1- Remove screws securing side flanges of top hood to unit. See figure 7.

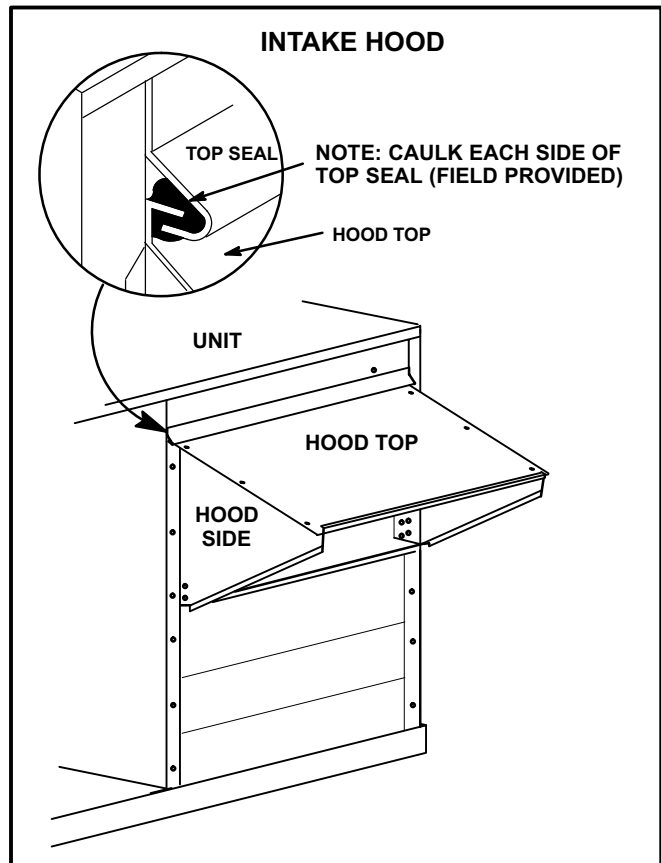

FIGURE 7

- 2- Pivot top hood open and secure sides of intake hood to top of hood using three sheet metal screws on each side. See figure 7.
- 3- Align two holes on intake hood side panel with two holes on bottom filter bracket. See figure 8. Secure both sides of bottom filter bracket to hood sides with sheet metal screws.
- 4- Secure intake hood sides to unit.

- 5- Slide two filters into bottom filter bracket. Position filler piece between filters with one end in bottom filter bracket.
- 6- Install top filter bracket as shown in figure 8. Secure with screws provided.

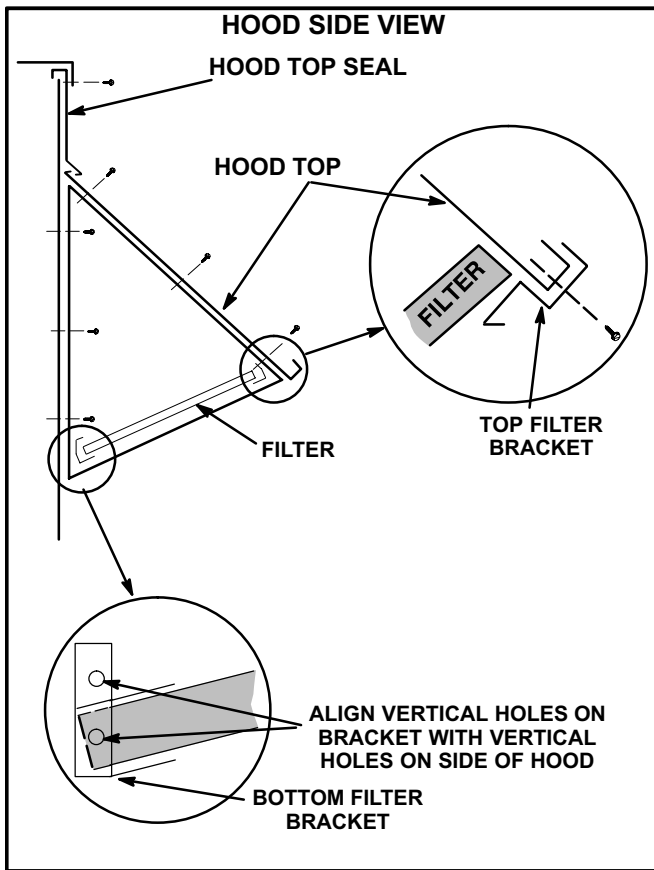

FIGURE 8

Electrical Connections

POWER SUPPLY

Do not apply power or close disconnect switch until installation is complete. Refer to start-up directions. Refer closely to unit wiring diagram.

Refer to unit nameplate for minimum circuit ampacity and maximum fuse size.

- 1- 230/460/575 volt units are factory wired. For 208V supply, disconnect the orange wire (230V) at control power transformer(s). Reconnect the red wire (208V). Tape the exposed end of the 230V orange wire.

- 2- Route power through the bottom power entry area and connect to TB2 or TB13. If unit contains an optional factory-installed circuit breaker or disconnect switch, connect line voltage to CB10 or S48. See unit wiring diagram.
- 3- Connect separate 120v wiring to optional GFCI outlet pigtails.

CONTROL WIRING

A-Thermostat Location

Room thermostat mounts vertically on a standard 2" X 4" handy box or on any non-conductive flat surface.

Locate thermostat approximately 5 feet (1524mm) above the floor in an area with good air circulation at average temperature. Avoid locating the room thermostat where it might be affected by:

- drafts or dead spots behind doors and in corners
- hot or cold air from ducts
- radiant heat from sun or appliances
- concealed pipes and chimneys

B-Control Wiring

- 1- Route thermostat cable or wires from subbase through knockout provided in unit. Use 18 AWG wire for all applications using remotely installed electro-mechanical and electronic thermostats.
- 2- Install thermostat assembly in accordance with instructions provided with thermostat. See figure 9 for field wiring electro-mechanical and electronic thermostats. If using other temperature control devices or energy management systems see instructions and wiring diagram provided by manufacturer.
- 3- *Humiditrol® Units Only* - Install humidity sensor in accordance with instructions provided with sensor. See figure 10 to wire units set in local thermostat mode. See figure 11 for units wired in zone sensor mode.

IMPORTANT-Terminal connections at the wall plate or subbase must be made securely. Loose control wire connections may allow unit to operate but not with proper response to room demand.

24 VOLT FIELD WIRING WITH ELECTRONIC AND ELECTRO-MECHANICAL THERMOSTATS

Note - On electro-mechanical thermostats set anticipator at 0.1 amps.

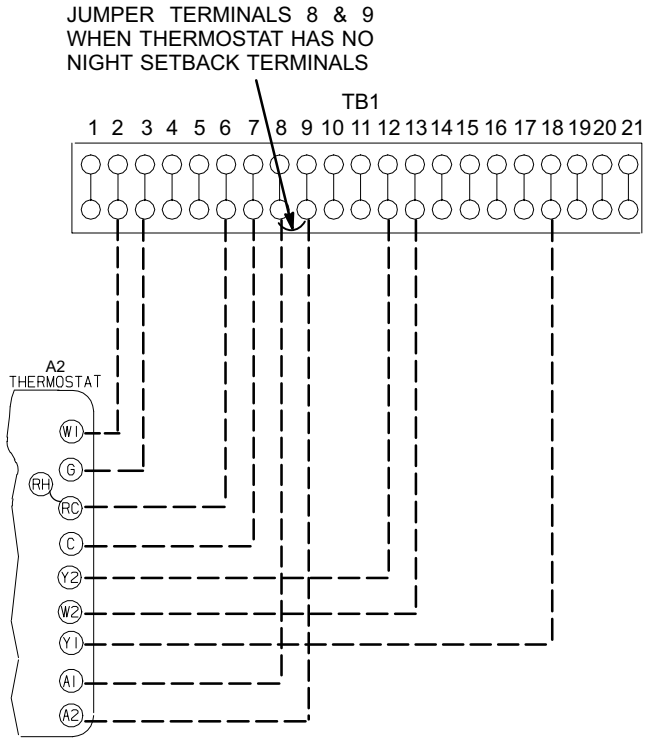

NOT ALL TERMINALS
ARE FOUND ON ALL
THERMOSTATS

FIGURE 9

24 VOLT FIELD WIRING WITH IMC SET IN LOCAL THERMOSTAT MODE (ECTO 6.01 OPTION 0)

JUMPER TERMINALS 8 & 9
WHEN THERMOSTAT HAS NO
NIGHT SETBACK TERMINALS

Note - On electro-mechanical thermostats set anticipator at 0.1 amps.

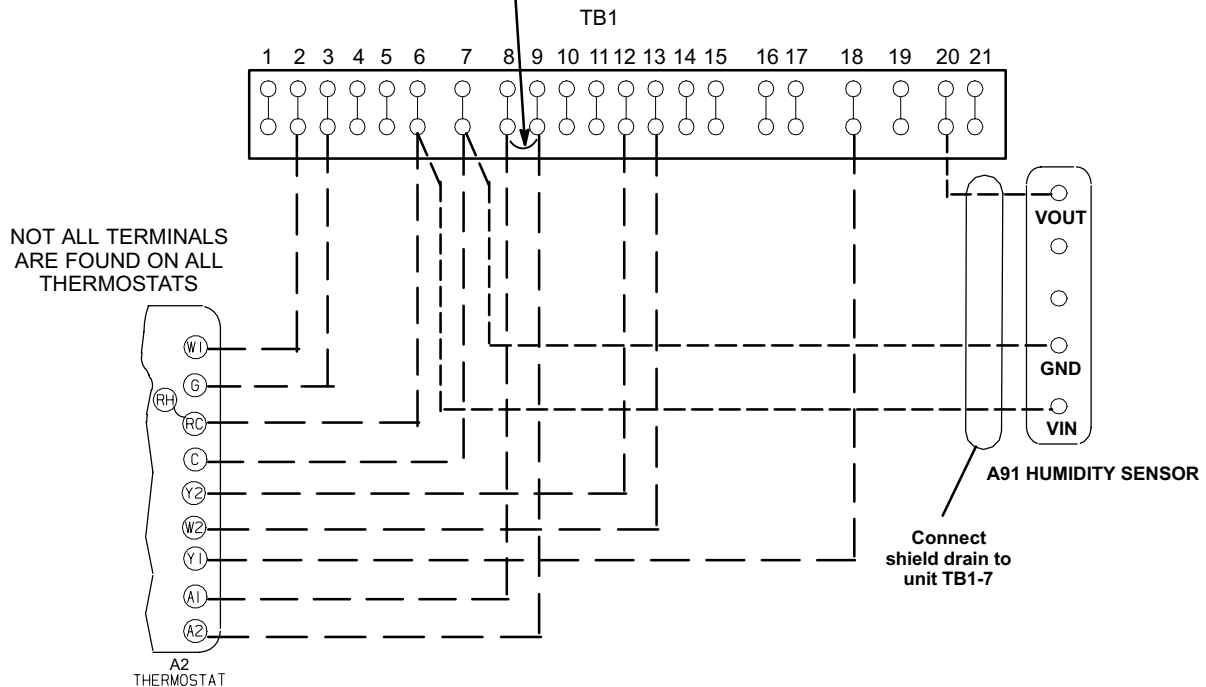

NOT ALL TERMINALS
ARE FOUND ON ALL
THERMOSTATS

FIGURE 10

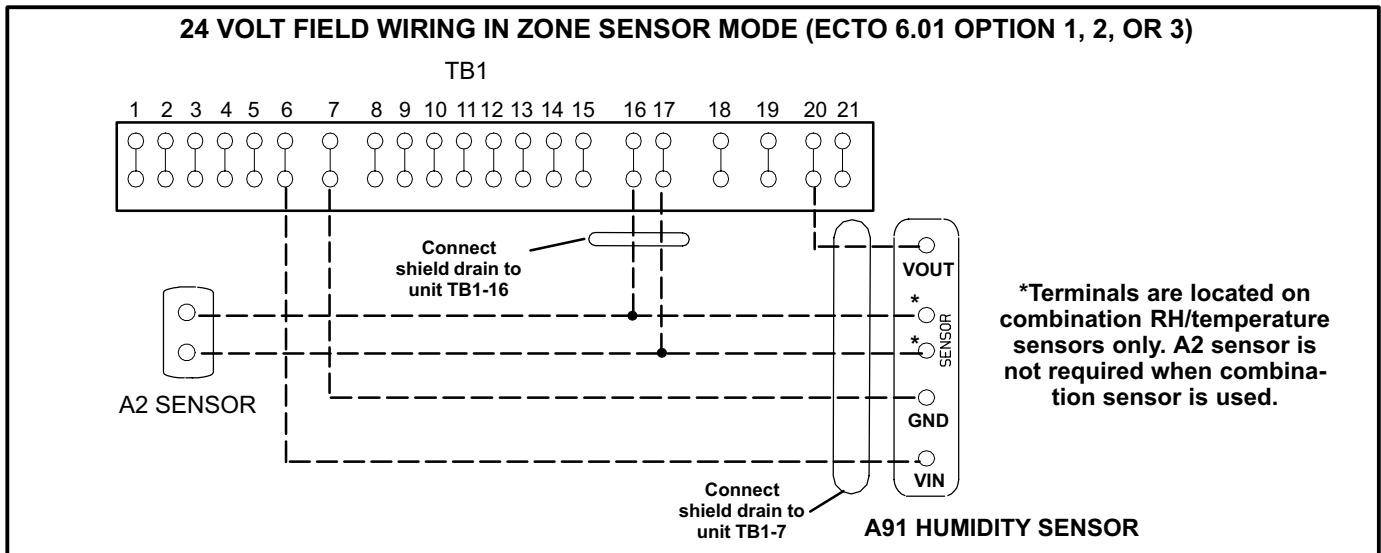

Blower Operation and Adjustments

⚠ IMPORTANT

Three phase scroll compressors must be phased sequentially for correct compressor and blower rotation. Follow “COOLING START-UP” section of installation instructions to ensure proper compressor and blower operation.

A-Blower Operation

Initiate blower demand at thermostat according to instructions provided with thermostat. Unit will cycle on thermostat demand. The following steps apply to applications using a typical electro-mechanical thermostat.

- 1- Blower operation is manually set at the thermostat subbase fan switch. With fan switch in **ON** position, blowers will operate continuously.
- 2- With fan switch in **AUTO** position, the blowers will cycle with demand. Blowers and entire unit will be off when system switch is in **OFF** position.

B-Blower Access

- 1- Disconnect jack/plug connector to blower motor. Also disconnect jack/plug connector heating limit switches on LGA/LGC units.
- 2- Remove screws on either side of blower assembly sliding base. See figure 12.
- 3- Pull base toward outside of unit.

C-Determining Unit CFM

- 1- The following measurements must be made with a dry indoor coil. Run blower without a cooling demand. Air filters must be in place when measurements are taken.

- 2- With all access panels in place, measure static pressure external to unit (from supply to return).
- 3- Measure the indoor blower shaft RPM.
- 4- Referring to table 3, use static pressure and RPM readings to determine unit CFM. Use table 4 when installing units with any of the optional accessories listed.
- 5- The blower RPM can be adjusted at the motor pulley. Loosen Allen screw and turn adjustable pulley clockwise to increase CFM. Turn counterclockwise to decrease CFM. See figure 12. Do not exceed minimum and maximum number of pulley turns as shown in table 2.

**TABLE 2
MINIMUM AND MAXIMUM PULLEY ADJUSTMENT**

Belt	Minimum Turns Open	Maximum Turns Open
A Section	0	5
B Section	1*	6

*0 Minimum turns open when B belt is used on pulleys 6" O.D. or larger.

D-Blower Belt Adjustment

Maximum life and wear can be obtained from belts only if proper pulley alignment and belt tension are maintained. Tension new belts after a 24-48 hour period of operation. This will allow belt to stretch and seat grooves. Make sure blower and motor pulley are aligned as shown in figure 13.

- 1- Loosen four bolts securing motor base to mounting frame. See figure 12.

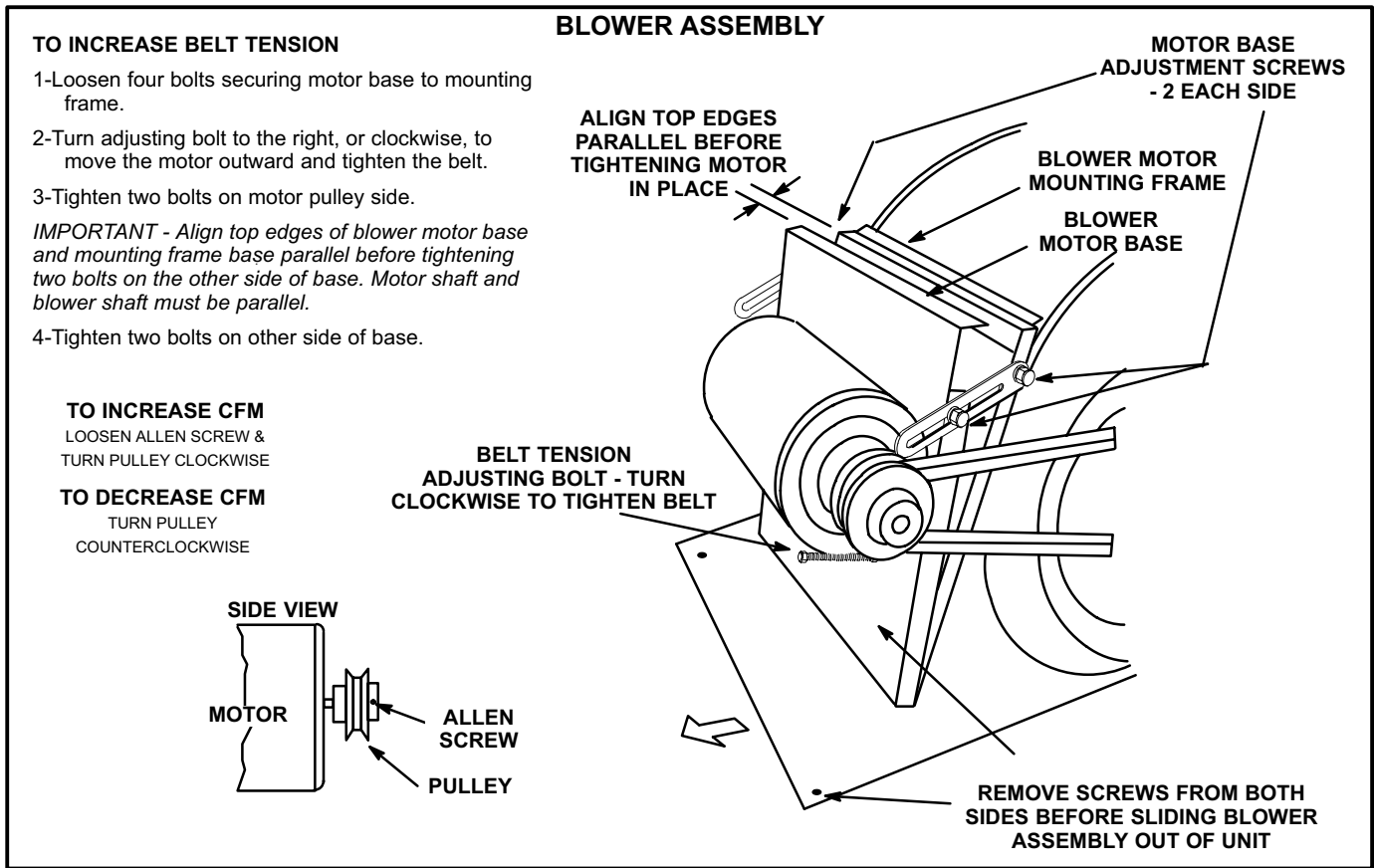

FIGURE 12

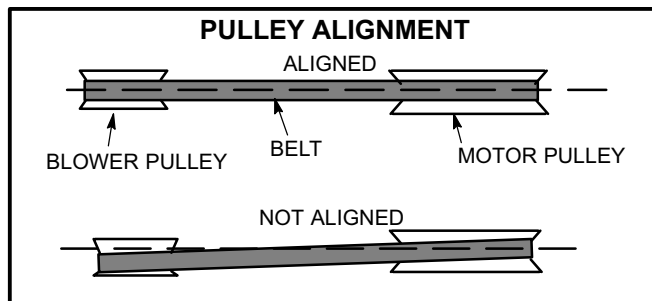

FIGURE 13

2- *To increase belt tension -*
Turn adjusting bolt to the right, or clockwise, to move the motor outward and tighten the belt. This increases the distance between the blower motor and the blower housing.

To loosen belt tension -

Turn the adjusting bolt to the left, or counterclockwise to loosen belt tension.

3- Tighten two bolts on motor pulley side.

IMPORTANT - Align top edges of blower motor base and mounting frame base parallel before tightening two bolts on the other side of base. Motor shaft and blower shaft must be parallel.

4- Tighten two bolts on other side of base.

E-Check Belt Tension

Overtensioning belts shortens belt and bearing life. Check belt tension as follows:

- 1- Measure span length X. See figure 14.
- 2- Apply perpendicular force to center of span (X) with enough pressure to deflect belt 1/64" for every inch of span length or 1.5mm per 100mm of span length.
Example: Deflection distance of a 40" span would be 40/64" or 5/8".
Example: Deflection distance of a 400mm span would be 6mm.
- 3- Measure belt deflection force. For a used belt, the deflection force should be 5 lbs. (35kPa). A new belt deflection force should be 7 lbs. (48kPa).

A force below these values indicates an undertensioned belt. A force above these values indicates an overtensioned belt.

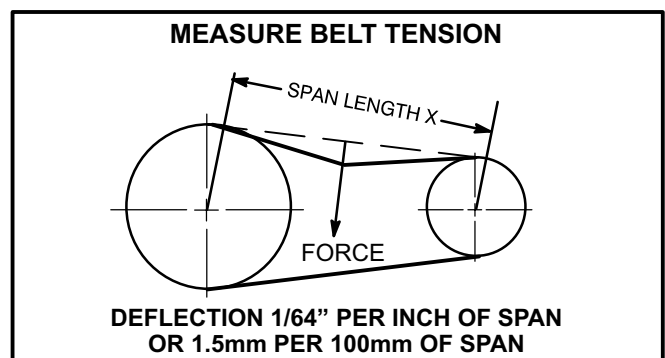

FIGURE 14

**TABLE 3
090, 102, 120, 150 BASE UNIT BLOWER PERFORMANCE**

**BLOWER TABLE INCLUDES RESISTANCE FOR BASE UNIT ONLY WITH DRY INDOOR COIL & AIR FILTERS IN PLACE.
FOR ALL UNITS ADD:**

- 1 - Wet indoor coil air resistance of selected unit.
- 2 - Any factory installed options air resistance (heat section, economizer, etc.)
- 3 - Any field installed accessories air resistance (duct resistance, diffuser, etc.)

Then determine from blower table blower motor output and drive required.
See table 4 for wet coil and option/accessory air resistance data.

MINIMUM AIR VOLUME REQUIRED FOR USE WITH OPTIONAL ELECTRIC HEAT

- LCA/LCC090, 102 requires 3000 cfm (1415 L/s) minimum air with electric heat.
- LCA/LCC120 & LCA/LCC150 models require 4000 cfm (1890 L/s) minimum air with electric heat.

BOLD ITALIC INDICATES FIELD FURNISHED DRIVE

Air Volume cfm (L/s)	Total Static Pressure - in. w.g. (Pa)												
	.20 (50)	.40 (100)	.60 (150)	.80 (200)	1.00 (250)	1.20 (300)	1.40 (350)	1.60 (400)	1.80 (450)	2.00 (495)	2.20 (545)	2.40 (595)	2.60 (645)
	RPM BHP (kW)	RPM BHP (kW)	RPM BHP (kW)	RPM BHP (kW)	RPM BHP (kW)	RPM BHP (kW)	RPM BHP (kW)	RPM BHP (kW)	RPM BHP (kW)	RPM BHP (kW)	RPM BHP (kW)	RPM BHP (kW)	RPM BHP (kW)
2250 (1060)	455 0.30 <i>(0.22)</i>	555 0.45 <i>(0.34)</i>	640 0.60 <i>(0.45)</i>	720 0.80 (0.60)	790 1.00 (0.75)	855 1.20 (0.90)	915 1.40 (1.04)	975 1.60 (1.19)	1030 1.85 (1.38)	1080 2.05 (1.53)	1130 2.30 (1.72)	1175 2.55 (1.90)	1220 2.80 (2.09)
2500 (1180)	475 0.40 <i>(0.30)</i>	575 0.55 <i>(0.41)</i>	660 0.70 <i>(0.52)</i>	735 0.90 (0.67)	805 1.10 (0.82)	870 1.30 (0.97)	930 1.55 (1.16)	985 1.75 (1.31)	1040 2.00 (1.49)	1090 2.25 (1.68)	1140 2.50 (1.87)	1185 2.75 (2.05)	1230 3.00 (2.24)
2750 (1300)	495 0.45 <i>(0.34)</i>	595 0.65 <i>(0.48)</i>	675 0.85 <i>(0.63)</i>	750 1.05 (0.78)	820 1.25 (0.93)	885 1.45 (1.08)	940 1.70 (1.27)	995 1.90 (1.42)	1050 2.20 (1.64)	1100 2.45 (1.83)	1145 2.65 (1.98)	1195 2.95 (2.20)	1240 3.25 (2.42)
3000 (1415)	525 0.55 <i>(0.41)</i>	615 0.75 <i>(0.56)</i>	695 0.95 (0.71)	770 1.20 (0.90)	835 1.40 (1.04)	895 1.60 (1.19)	955 1.85 (1.38)	1010 2.10 (1.57)	1060 2.35 (1.75)	1110 2.65 (1.98)	1160 2.90 (2.16)	1205 3.20 (2.39)	1250 3.45 (2.57)
3250 (1535)	550 0.65 <i>(0.48)</i>	640 0.90 <i>(0.67)</i>	715 1.10 (0.82)	790 1.35 (1.01)	855 1.60 (1.19)	915 1.80 (1.34)	970 2.05 (1.53)	1025 2.35 (1.75)	1075 2.60 (1.94)	1125 2.85 (2.13)	1170 3.15 (2.35)	1215 3.40 (2.54)	1260 3.70 (2.76)
3500 (1650)	580 0.80 <i>(0.60)</i>	665 1.05 <i>(0.78)</i>	740 1.25 (0.93)	810 1.50 (1.12)	870 1.75 (1.31)	930 2.00 (1.49)	985 2.25 (1.68)	1040 2.55 (1.90)	1090 2.85 (2.13)	1135 3.10 (2.31)	1185 3.40 (2.54)	1230 3.70 (2.76)	1270 4.00 (2.98)
3750 (1770)	605 0.95 <i>(0.71)</i>	690 1.20 (0.90)	760 1.45 (1.08)	830 1.70 (1.27)	890 1.95 (1.45)	950 2.25 (1.68)	1005 2.50 (1.87)	1055 2.80 (2.09)	1105 3.10 (2.31)	1150 3.35 (2.50)	1195 3.65 (2.72)	1240 3.95 (2.95)	1285 4.30 (3.21)
4000 (1890)	635 1.10 <i>(0.82)</i>	715 1.40 (1.04)	785 1.65 (1.23)	850 1.90 (1.42)	910 2.20 (1.64)	965 2.45 (1.83)	1020 2.75 (2.05)	1070 3.05 (2.28)	1120 3.35 (2.50)	1165 3.65 (2.72)	1210 3.95 (2.95)	1255 4.30 (3.21)	1295 4.60 (3.43)
4250 (2005)	665 1.30 <i>(0.97)</i>	740 1.60 (1.19)	810 1.85 (1.38)	870 2.15 (1.60)	930 2.45 (1.83)	985 2.75 (2.05)	1040 3.05 (2.28)	1090 3.35 (2.50)	1135 3.65 (2.72)	1185 4.00 (2.98)	1225 4.30 (3.21)	1270 4.65 (3.47)	1310 4.95 (3.69)
4500 (2125)	695 1.50 (1.12)	770 1.80 (1.34)	835 2.10 (1.57)	895 2.40 (1.79)	955 2.70 (2.01)	1005 3.00 (2.24)	1060 3.35 (2.50)	1105 3.65 (2.72)	1155 4.00 (2.98)	1200 4.30 (3.21)	1245 4.65 (3.47)	1285 5.00 (3.73)	1325 5.30 (3.95)
4750 (2240)	725 1.75 (1.31)	795 2.05 (1.53)	860 2.40 (1.79)	920 2.70 (2.01)	975 3.00 (2.24)	1030 3.35 (2.50)	1080 3.65 (2.72)	1125 3.95 (2.95)	1175 4.35 (3.25)	1215 4.65 (3.47)	1260 5.00 (3.73)	1300 5.35 (3.99)	1340 5.70 (4.25)
5000 (2360)	760 2.05 (1.53)	825 2.35 (1.75)	885 2.65 (1.98)	945 3.00 (2.24)	1000 3.35 (2.50)	1050 3.65 (2.72)	1100 4.00 (2.98)	1145 4.35 (3.25)	1190 4.70 (3.51)	1235 5.05 (3.77)	1280 5.45 (4.07)	----	----
5250 (2475)	790 2.30 (1.72)	855 2.65 (1.98)	910 2.95 (2.20)	970 3.35 (2.50)	1020 3.65 (2.72)	1070 4.00 (2.98)	1120 4.35 (3.25)	1165 4.70 (3.51)	1210 5.10 (3.80)	1255 5.45 (4.07)	----	----	----
5500 (2595)	820 2.60 (1.94)	880 2.95 (2.20)	940 3.30 (2.46)	995 3.70 (2.76)	1045 4.05 (3.02)	1095 4.40 (3.28)	1145 4.80 (3.58)	1190 5.15 (3.84)	1230 5.50 (4.10)	----	----	----	----
5750 (2715)	850 2.95 (2.20)	910 3.30 (2.46)	965 3.70 (2.76)	1020 4.05 (3.02)	1070 4.45 (3.32)	1120 4.80 (3.58)	1165 5.20 (3.88)	1210 5.60 (4.18)	----	----	----	----	----
6000 (2830)	885 3.35 (2.50)	940 3.70 (2.76)	995 4.10 (3.06)	1045 4.45 (3.32)	1095 4.85 (3.62)	1145 5.25 (3.92)	1190 5.65 (4.21)	----	----	----	----	----	----

F-Field-Furnished Blower Drives

For field-furnished blower drives, use tables 3 and 4 to determine BHP and RPM required. Reference table 5 to

determine the drive number and table 6 to determine the manufacturer's model number.

**TABLE 4
FACTORY INSTALLED OPTIONS/FIELD INSTALLED ACCESSORY AIR RESISTANCE**

Air Volume		Wet Indoor Coil		Gas Heat Exchanger (LGA/LGC Models)		Electric Heat (LCA/LCC Models)	Economizer
cfm	L/s	090, 102	120S 120H 150S	Low Fire	High Fire		
2250	1060	.06 (15)	.10 (25)	.05 (12)	.09 (22)	.01 (2)	.035 (9)
2500	1180	.08 (20)	.12 (30)	.05 (12)	.11 (27)	.01 (2)	.04 (10)
2750	1300	.09 (22)	.14 (35)	.06 (15)	.13 (32)	.01 (2)	.045 (11)
3000	1415	.10 (25)	.16 (40)	.07 (17)	.16 (40)	.02 (5)	.05 (12)
3250	1535	.11 (27)	.19 (47)	.08 (20)	.19 (47)	.02 (5)	.06 (15)
3500	1650	.13 (32)	.21 (52)	.09 (22)	.22 (55)	.03 (7)	.07 (17)
3750	1770	.14 (35)	.23 (57)	.10 (25)	.26 (65)	.03 (7)	.075 (19)
4000	1890	.16 (40)	.26 (65)	.11 (27)	.30 (75)	.04 (10)	.08 (20)
4250	2005	.17 (42)	.28 (70)	.12 (30)	.34 (85)	.04 (10)	.09 (22)
4500	2125	.18 (45)	.31 (77)	.13 (32)	.38 (94)	.05 (12)	.10 (25)
4750	2240	.20 (50)	.33 (82)	.14 (35)	.42 (104)	.05 (12)	.11 (27)
5000	2360	.22 (55)	.36 (90)	.16 (40)	.47 (117)	.06 (15)	.12 (30)
5250	2475	.24 (60)	.39 (97)	.18 (45)	.52 (129)	.06 (15)	.13 (32)
5500	2595	.26 (65)	.42 (104)	.20 (50)	.57 (142)	.07 (17)	.14 (35)
5750	2715	.28 (70)	.45 (112)	.22 (55)	.62 (154)	.07 (17)	.15 (37)
6000	2830	.30 (75)	.68 (169)	.24 (60)	.68 (169)	.08 (20)	.16 (40)

**TABLE 5
FACTORY INSTALLED DRIVE KIT SPECIFICATIONS**

Motor		RPM Range											
hp	kW	Drive 1		Drive 2		Drive 3		Drive 4		Drive 5		Drive 6	
		60 Hz	50 Hz	60 Hz	50 Hz	60 Hz	50 Hz	60 Hz	50 Hz	60 Hz	50 Hz	60 Hz	50 Hz
2	1.5	680-940	560-775	---	---	850-1130	700-930	---	---	---	917-1152	---	---
3 Std.	2.2	680-940	---	---	560-775	850-1130	---	---	740-925	1105-1410	---	---	915-1150
3 Hi Eff	2.2	---	---	680-895	---	---	---	895-1120	---	---	---	1110-1395	---
5	3.7	---	---	---	---	---	---	895-1120	740-925	---	---	1110-1395	915-1150

In Canada, nominal motor output is also maximum usable motor output. If motors of comparable output are used, be sure to keep within the service factor limitations outlined on the motor nameplate.

**TABLE 6
MANUFACTURER'S NUMBERS**

DRIVE NO.	DRIVE COMPONENTS					
	ADJUSTABLE SHEAVE		FIXED SHEAVE		BELT	
	BROWNING NO.	OEM PART NO.	BROWNING NO.	OEM PART NO.	BROWNING NO.	OEM PART NO.
1	1VP40x7/8	79J0301	AK69x1	36K4701	AX46	31K7101
2	1VP44x1-1/8	36C0701	BK85x1	49K4101	BX52	P-8-8094
3	1VP44x7/8	53J9601	AK64x1	12L2501	AX46	31K7101
4	1VP60x1-1/8	41C1301	BK95x1	79J2701	BX56	P-8-10082
5	1VP50x7/8	P-8-2187	AK59x1	31K6801	AX46	31K7101
6	1VP60x1-1/8	41C1301	BK77x1	49K4001	BX53	49K3801

Cooling Start-Up

IMPORTANT-The crankcase heater must be energized for 24 hours before attempting to start compressor. Set thermostat so there is no demand to prevent compressors from cycling. Apply power to unit.

⚠ IMPORTANT

Units contain either R22 or R410A refrigerant. Check the nameplate to determine the type of refrigerant before installation or servicing.

NOTE - These units must not be used as a “construction heater” at any time during any phase of construction. Very low return air temperatures, harmful vapors, and misplacement of the filters will damage the unit and its efficiency. Additionally, a unit which will be subject to cold temperatures when not in operation must have a vapor barrier installed to seal the duct connections. Failure to protect the unit from moisture laden air or harmful vapors (generated from the construction process and temporary combustion heating equipment) will cause corrosive condensation within the unit. Failure to properly protect the unit in this situation will cause electrical and electronic component failure and could affect the unit warranty status.

A-Preliminary Checks

- 1- Make sure that unit is installed in accordance with the installation instructions and applicable codes.
- 2- Inspect all electrical wiring, both field- and factory-installed, for loose connections. Tighten as required.
- 3- Check to ensure that refrigerant lines do not rub against the cabinet or against other refrigerant lines.
- 4- Check voltage at disconnect switch. Voltage must be within range listed on nameplate. If not, consult power company and have voltage condition corrected before starting unit.
- 5- Make sure filters are in place before start-up.

B-Start-Up

- 1- Initiate first and second stage cooling demands according to instructions provided with thermostat.
- 2- First-stage thermostat demand will energize compressor 1. Second-stage thermostat demand will energize compressor 2. On units with an economizer, when outdoor air is acceptable, a first-stage demand will energize the economizer; a second-stage demand will energize compressor 1.
- 3- Units contain two refrigerant circuits or stages. See figure 15.

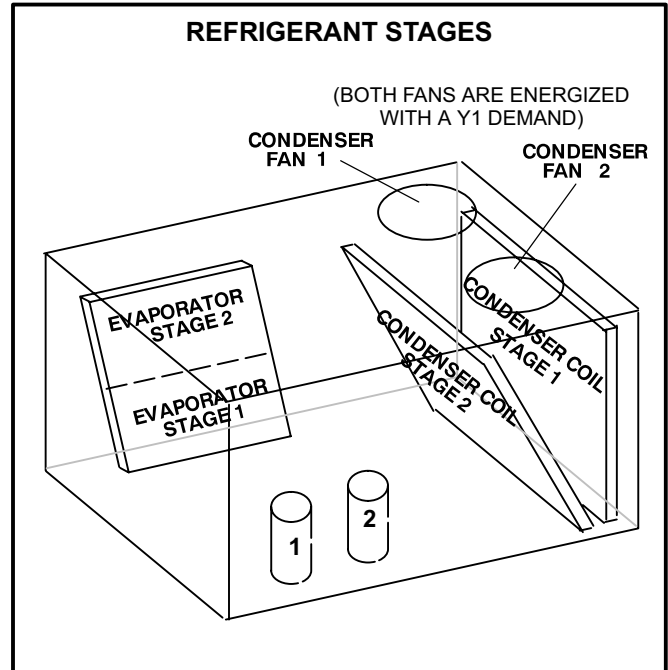

FIGURE 15

- 4- Each refrigerant circuit is charged with either HCFC-22 or R410A refrigerant. See unit rating plate for type of refrigerant and correct amount of charge.
- 5- Refer to Cooling Operation and Adjustment section for proper method to check refrigerant charge.

C-Three Phase Scroll Compressor Voltage Phasing

Three phase scroll compressors must be phased sequentially to ensure correct compressor and blower rotation and operation. Compressor and blower are wired in phase at the factory. Power wires are color-coded as follows: line 1-red, line 2-yellow, line 3-blue.

- 1- Observe suction and discharge pressures and blower rotation on unit start-up.
- 2- Suction pressure must drop, discharge pressure must rise, and blower rotation must match rotation marking.

If pressure differential is not observed or blower rotation is not correct:

- 3- Disconnect all remote electrical power supplies.
- 4- Reverse any two field-installed wires connected to the line side of S48 disconnect or TB13 terminal strip. Do not reverse wires at blower contactor.
- 5- Make sure the connections are tight.

Discharge and suction pressures should operate at their normal start-up ranges.

D-R410A Refrigerant

Units charged with R410A refrigerant operate at much higher pressures than R22. The expansion valve and liquid line drier provided with the unit are approved for use with R410A. Do not replace them with components designed for use with R22.

R410A refrigerant is stored in a pink cylinder.

Manifold gauge sets used with systems charged with R410A refrigerant must be capable of handling the higher system operating pressures. The gauges should be rated for use with pressures of 0-800 on the high side and a low side of 30" vacuum to 250 psi with dampened speed to 500 psi. Gauge hoses must be rated for use at up to 800 psi of pressure with a 4000 psi burst rating.

⚠ IMPORTANT

Mineral oils are not compatible with R410A. If oil must be added, it must be a polyol ester oil.

E-Refrigerant Charge and Check

WARNING-Do not exceed nameplate charge under any condition.

This unit is factory charged and should require no further adjustment. If the system requires charge, *reclaim the charge, evacuate the system, and add required nameplate charge.*

*NOTE - System charging is not recommended below 60°F (15°C). In temperatures below 60°F (15°C), the charge **must** be weighed into the system.*

If weighing facilities are not available, or to check the charge, use the following procedure:

IMPORTANT - Charge unit in standard cooling mode.

- 1- Attach gauge manifolds and operate unit in cooling mode until system stabilizes (approximately five minutes). Make sure outdoor air dampers are closed.
- 2- Check each system separately with all stages operating.
- 3- Use a thermometer to accurately measure the outdoor ambient temperature.
- 4- Apply the outdoor temperature to tables 7 through 18 to determine normal operating pressures.
- 5- Compare the normal operating pressures to the pressures obtained from the gauges. Minor variations in these pressures may be expected due to differences in installations. Significant differences could mean that the system is not properly charged or that a problem exists with some component in the system. **Correct any system problems before proceeding.**

6- If discharge pressure is high, remove refrigerant from the system. If discharge pressure is low, add refrigerant to the system.

- Add or remove charge in increments.
- Allow the system to stabilize each time refrigerant is added or removed.

7- Use the following approach method along with the normal operating pressures to confirm readings.

**TABLE 7
LGC/LCC090S R22**

Outdoor Coil Entering Air Temp	CIRCUIT 1		CIRCUIT 2	
	Dis-charge ±10 psig	Suction ±5 psig	Dis-charge ±10 psig	Suction ±5 psig
65°F	179	76	183	74
75°F	204	78	209	76
85°F	233	79	237	77
95°F	265	81	270	79
105°F	299	83	304	81
115°F	335	84	342	83

**TABLE 8
LGA/LCA090H R22**

Outdoor Coil Entering Air Temp	CIRCUIT 1		CIRCUIT 2	
	Dis. ±10 psig	Suct. ±5 psig	Dis. ±10 psig	Suc. ±5 psig
65°F	160	78	165	78
75°F	184	80	190	80
85°F	211	82	218	81
95°F	241	83	248	82
105°F	272	84	279	83
115°F	310	86	319	85

**TABLE 9
LGA/LCA090H Humiditrol®**

Outdoor Coil Entering Air Temp	CIRCUIT 1		CIRCUIT 2	
	Dis. ±10 psig	Suct. ±5 psig	Dis. ±10 psig	Suc. ±5 psig
65°F	167	78	165	78
75°F	188	80	190	80
85°F	216	82	218	81
95°F	248	83	248	82
105°F	280	84	279	83
115°F	313	86	319	85

**TABLE 10
LGC/LCC102S R22**

Outdoor Coil Entering Air Temp	CIRCUIT 1		CIRCUIT 2	
	Dis. ±10 psig	Suct. ±5 psig	Dis. ±10 psig	Suc. ±5 psig
65°F	181	78	197	79
75°F	205	79	223	80
85°F	232	79	252	81
95°F	261	80	283	82
105°F	294	82	318	85
115°F	327	83	354	86

TABLE 11
LCA/LGA102H R22

Outdoor Coil Entering Air Temp	CIRCUIT 1		CIRCUIT 2	
	Dis. ±10 psig	Suct. ±5 psig	Dis. ±10 psig	Suc. ±5 psig
65°F	155	78	163	78
75°F	185	79	193	79
85°F	216	60	222	80
95°F	247	81	252	82
105°F	277	82	282	84
115°F	308	83	311	85

TABLE 15
LGC/LCC120S R410A

Outdoor Coil Entering Air Temp	CIRCUIT 1		CIRCUIT 2	
	Dis-charge ±10 psig	Suction ±5 psig	Dis-charge ±10 psig	Suction ±5 psig
65°F	283	128	289	130
75°F	323	131	330	133
85°F	370	134	375	136
95°F	417	136	421	138
105°F	470	139	473	140
115°F	526	141	529	142

TABLE 12
LGA/LCA102H Humiditrol®

Outdoor Coil Entering Air Temp	CIRCUIT 1		CIRCUIT 2	
	Dis. ±10 psig	Suct. ±5 psig	Dis. ±10 psig	Suc. ±5 psig
65°F	166	77	163	78
75°F	192	79	193	79
85°F	221	80	222	80
95°F	252	82	252	82
105°F	285	83	282	84
115°F	323	85	311	85

TABLE 16
LCA/LGA120H Humiditrol®

Outdoor Coil Entering Air Temp	CIRCUIT 1		CIRCUIT 2	
	Dis. ±10 psig	Suct. ±5 psig	Dis. ±10 psig	Suc. ±5 psig
65°F	182	78	172	74
75°F	205	77	203	75
85°F	233	77	233	77
95°F	264	79	264	79
105°F	298	80	295	82
115°F	339	83	326	84

TABLE 13
LCC/LGC120S R22

Outdoor Coil Entering Air Temp	CIRCUIT 1		CIRCUIT 2	
	Dis. ±10 psig	Suct. ±5 psig	Dis. ±10 psig	Suc. ±5 psig
65°F	180	77	189	76
75°F	206	78	217	77
85°F	234	80	246	80
95°F	265	82	279	82
105°F	297	83	312	83
115°F	334	84	349	85

TABLE 17
LGC/LCC150S R22

Outdoor Coil Entering Air Temp	CIRCUIT 1		CIRCUIT 2	
	Dis. ±10 psig	Suct. ±5 psig	Dis. ±10 psig	Suc. ±5 psig
65°F	176	65	185	69
75°F	200	66	209	71
85°F	229	68	236	72
95°F	260	71	265	73
105°F	293	73	297	75
115°F	330	75	332	76

TABLE 14
LCA/LGA120H R22

Outdoor Coil Entering Air Temp	CIRCUIT 1		CIRCUIT 2	
	Dis. ±10 psig	Suct. ±5 psig	Dis. ±10 psig	Suc. ±5 psig
65°F	166	75	172	74
75°F	197	76	203	75
85°F	227	78	233	77
95°F	258	80	264	79
105°F	288	82	295	82
115°F	320	84	326	84

TABLE 18
LCC/LGC150S Humiditrol®

Outdoor Coil Entering Air Temp	CIRCUIT 1		CIRCUIT 2	
	Dis. ±10 psig	Suct. ±5 psig	Dis. ±10 psig	Suc. ±5 psig
65°F	187	65	185	69
75°F	205	66	209	71
85°F	234	68	236	72
95°F	264	71	265	73
105°F	301	73	297	75
115°F	344	75	332	76

F-Charge Verification - Approach Method

- Using the same thermometer, compare liquid temperature to outdoor ambient temperature.

Approach Temperature = Liquid temperature minus ambient temperature.

- Approach temperature should match values in table 19. An approach temperature greater than value shown indicates an undercharge. An approach temperature less than value shown indicates an overcharge.
- Do not use the approach method if system pressures do not match pressures in tables 7 through 18. The approach method is not valid for grossly over or undercharged systems.

**TABLE 19
APPROACH TEMPERATURE**

Unit	Liquid Temp. Minus Ambient Temp.	
	1st Stage	2nd Stage
090S	12°F ± 1 (6.7°C ± 0.5)	15°F ± 1 (8.3°C ± 0.5)
090H	7°F ± 1 (3.8°C ± 0.5)	7°F ± 1 (3.8°C ± 0.5)
102S	9°F ± 1 (5°C ± 0.5)	14°F ± 1 (7.7°C ± 0.5)
102H	7°F ± 1 (3.8°C ± 0.5)	8°F ± 1 (4.4°C ± 0.5)
120S	9°F ± 1 (5°C ± 0.5)	13°F ± 1 (7.1°C ± 0.5)
120H, 150S	7°F ± 1 (3.8°C ± 0.5)	7°F ± 1 (3.8°C ± 0.5)
090H Humiditrol	4°F ± 1 (2.2°C ± 0.5)	7°F ± 1 (3.8°C ± 0.5)
102H Humiditrol	5°F ± 1 (2.7°C ± 0.5)	8°F ± 1 (4.4°C ± 0.5)
120H Humiditrol	5°F ± 1 (2.7°C ± 0.5)	7°F ± 1 (3.8°C ± 0.5)
150S Humiditrol	8°F ± 1 (4.4°C ± 0.5)	7°F ± 1 (3.8°C ± 0.5)
120S R410A	9°F ± 1 (5°C ± 0.5)	10°F ± 1 (5.6°C ± 0.5)

G-Compressor Controls

See unit wiring diagram to determine which controls are used on each unit.

- High Pressure Switch (S4, S7) **R22**
The compressor circuit is protected by a high pressure switch which cuts out at 450 psig ± 10 psig (3103 kPa ± 70 kPa) and automatically resets at 300 psig ± 20psig (2069kPa ± 138kPa).

High Pressure Switch (S4, S7) **R410A**
The compressor circuit is protected by a high pressure switch which opens at 640 psig ± 10 psig (4413 kPa ± 70 kPa) and automatically resets at 475 psig ± 20 psig (3275kPa ± 138 kPa).

- Low Pressure Switch (S87, S88) **R22**
The compressor circuit is protected by a low pressure switch. Switch cuts out at 25 psig (172 kPa) and automatically resets at 55 psig (379 kPa).

Low Pressure Switch (S87, S88) **R410A**
The compressor circuit is protected by a loss of charge switch. Switch opens at 40 psig ± 5 psig (276 ± 34 kPa) and automatically resets at 90 psig ± 5 psig (621 kPa ± 34 kPa).

- Crankcase Heater (HR1, HR2)
Compressors have belly band compressor oil heaters which must be on 24 hours before running compressors. Energize by setting thermostat so that there is no cooling demand, to prevent compressor from cycling, and apply power to unit.

- Low Ambient Pressure Switch (S11, S84) **R22**
Switch maintains adequate discharge pressure by de-energizing condenser fan when liquid pressure falls below 150 psig (1034kPa). S11 is installed in stage 1 liquid line and S84 is installed in stage 2 liquid line. Switch closes to energize condenser fans when pressure rises to 275 psig (1896kPa).

Low Ambient Pressure Switch (S11, S84) **R410A**
Switch maintains adequate discharge pressure by de-energizing condenser fan when liquid pressure falls below 240 psig ±10 (1655 kPa±69). S11 is installed in the liquid line. Switch closes to energize condenser fan when pressure rises to 450 psig ±10 (3103kPa ± 69).

Both condenser fans are energized on a Y1 cooling demand and continue to operate when Y2 demand is initiated. If **BOTH** switches cut out due to low pressure, **ONLY** stage 1 condenser fan is cycled.

The C1 (A57) controller de-energizes condenser fan 2 when outdoor temperature drops below 55°F (13°C).

- Freezestats (S49, S50)
Switches de-energize compressors when evaporator coil temperature falls below 29°F (-2°C) to prevent evaporator freeze-up. Switches reset when evaporator coil temperature reaches 58°F (15°C).

Gas Heat Start-Up (LGA/LGC Units)

FOR YOUR SAFETY READ BEFORE LIGHTING

⚠ WARNING



Electric shock hazard. Can cause injury or death. Do not use this unit if any part has been under water. Immediately call a qualified service technician to inspect the unit and to replace any part of the control system and any gas control which has been under water.

⚠ WARNING



Danger of explosion. Can cause injury or product or property damage. If overheating occurs or if gas supply fails to shut off, shut off the manual gas valve to the appliance before shutting off electrical supply.

⚠ WARNING



Electric shock hazard. Can cause injury or death. Before attempting to perform any service or maintenance, turn the electrical power to unit OFF at disconnect switch(es). Unit may have multiple power supplies.

⚠ WARNING

SMOKE POTENTIAL

The heat exchanger in this unit could be a source of smoke on initial firing. Take precautions with respect to building occupants and property. Vent initial supply air outside when possible.

BEFORE LIGHTING smell all around the appliance area for gas. Be sure to smell next to the floor because some gas is heavier than air and will settle on the floor.

Use only your hand to push in or turn the gas control knob. Never use tools. If the knob will not push in or turn by hand, do not try to repair it, call a qualified service technician. Force or attempted repair may result in a fire or explosion.

⚠ WARNING



Danger of explosion. Can cause injury or death. Do not attempt to light manually. Unit has a direct spark ignition system.

This unit is equipped with an automatic spark ignition system. There is no pilot. In case of a safety shutdown, move thermostat switch to **OFF** and return the thermostat switch to **HEAT** to reset ignition control.

A-Placing Unit In Operation

⚠ WARNING



Danger of explosion and fire. Can cause injury or product or property damage. You must follow these instructions exactly.

Gas Valve Operation for White Rodgers 36C (figure 16) and Honeywell VR8205Q/VR8305Q (figure 17)

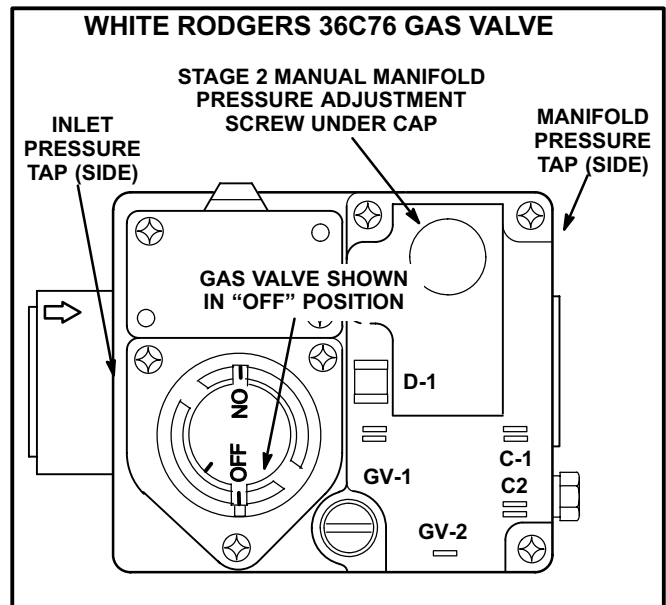

FIGURE 16

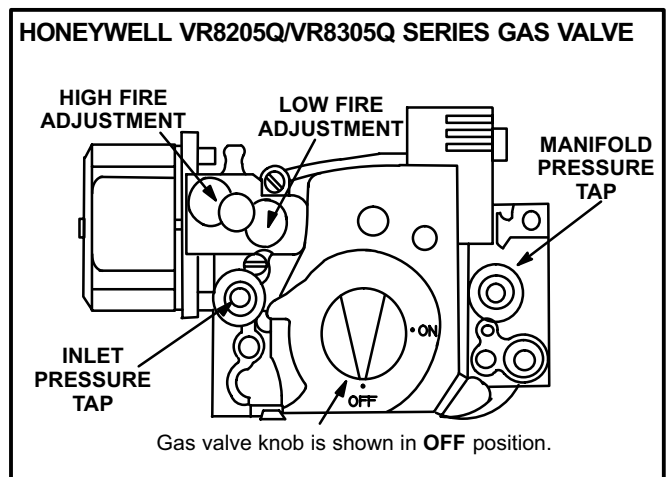





FIGURE 17

- 1- Set thermostat to lowest setting.
- 2- Turn off all electrical power to appliance.

- 3- This appliance is equipped with an ignition device which automatically lights the burner. Do **not** try to light the burner by hand.
- 4- Open or remove the heat section access panel.
- 5- Turn the knob on the gas valve clockwise  to “OFF”. Depress 36C knob slightly. Do not force.
- 6- Wait five (5) minutes to clear out any gas. If you then smell gas, **STOP!** Immediately call your gas supplier from a neighbor’s phone. Follow the gas supplier’s instructions. If you do not smell gas, go to the next step.
- 7- Turn the knob on the gas valve counterclockwise  to “ON”. Do not force.
- 8- Close or replace the heat section access panel.
- 9- Turn on all electrical power to appliance.
- 10- Set thermostat to desired setting.
- 11- The combustion air inducer will start. The burners will light within 40 seconds.
- 12- If the appliance does not light the first time (gas line not fully purged), it will attempt up to two more ignitions before locking out.
- 13- If lockout occurs, repeat steps 1 through 10.
- 14- If the appliance will not operate, follow the instructions “Turning Off Gas to Appliance” and call your service technician or gas supplier.

Turning Off Gas to Unit

- 1- If using an electromechanical thermostat, set to the lowest setting.
- 2- Before performing any service, turn off all electrical power to the appliance.
- 3- Open or remove the heat section access panel.
- 4- Turn the knob on the gas valve clockwise  to “OFF”. Depress 36C knob slightly. Do not force.
- 5- Close or replace the heat section access panel.

WARNING

 **Danger of explosion. Can cause injury or death. Do not attempt to light manually. Unit has a direct spark ignition system.**

Heating Operation and Adjustments

(LGA/LGC Units)

A-Heating Sequence of Operation

- 1- On a heating demand the combustion air inducer starts immediately.
- 2- Combustion air pressure switch proves inducer operation, then allows power to ignition control. Switch is factory set and requires no adjustment.
- 3- After a 45-second prepurge, spark ignitor energizes and gas valve solenoid opens.
- 4- Spark ignites gas, ignition sensor proves the flame and combustion continues.
- 5- If flame is not detected after first ignition trial, ignition control will repeat steps 3 and 4 two more times before locking out the gas valve.
- 6- For troubleshooting purposes, an ignition attempt after lock out may be re-established manually. Move thermostat to “OFF” and return thermostat switch to “HEAT” position.

B-Limit Controls

Limit controls are factory-set and are not adjustable. The primary limit is located on the blower deck behind the blower housing.

C-Heating Adjustment

Main burners are factory-set and do not require adjustment.

Check the spark gap on the ignitor and the position of the flame sensor as follows:

- 1- Loosen four screws and remove burner support cap. See figure 18.

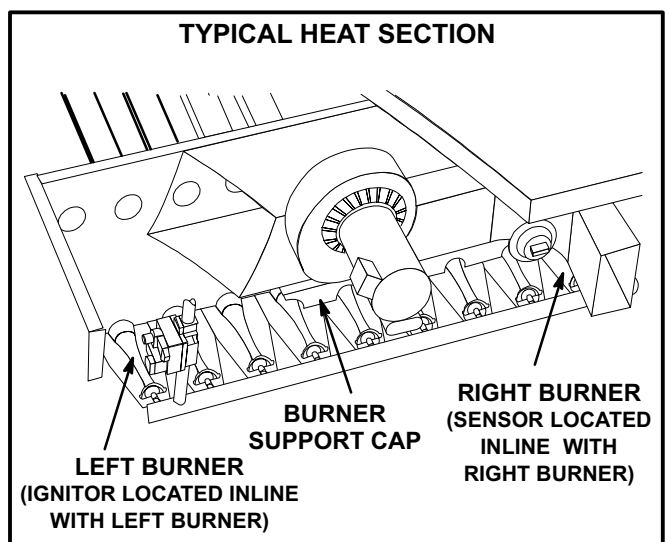

FIGURE 18

- 2- Remove left burner and check spark gap with appropriately sized twist drills or feeler gauges. See figure 19.
- 3- Remove the right burner and check the alignment of the ignition sensor. See figure 20.
- 4- Replace burners and burner support cap. Secure cap in place with retained screws.
- 5- The following manifold pressures are listed on the gas valve.
 - Natural Gas Units - Low Fire - 1.6" w.c. (not adjustable)
 - Natural Gas Units - High Fire - 3.7" w.c.
 - LP Gas Units - Low Fire - 5.5" w.c. (not adjustable)
 - LP Gas Units - High Fire - 10.5" w.c.

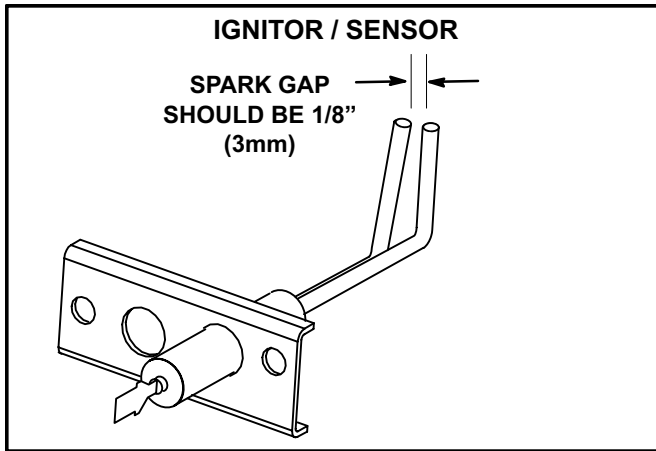

FIGURE 19

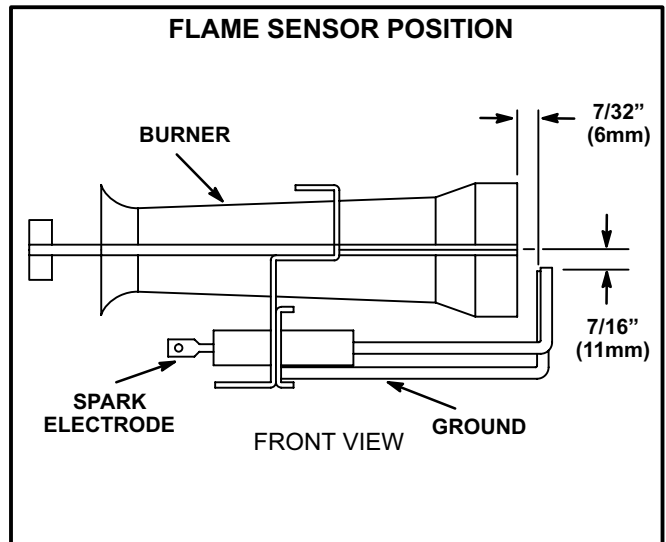

FIGURE 20

Electric Heat Start-Up (LCA/LCC Units)

Factory- or Field-Installed Option

Electric heat will stage on and cycle with thermostat demand. Number of stages of electric heat will vary depending on electric heat assembly. See electric heat wiring diagram on unit for sequence of operation.

Humiditrol® Start-Up And Operation

General

Humiditrol units provide a dehumidifying mode of operation. These units contain a reheat coil adjacent to and downstream of the evaporator coil. Reheat coil

solenoid valve, L14, routes hot discharge gas from the compressor to the reheat coil. Return air pulled across the evaporator coil is cooled and dehumidified; the reheat coil adds heat to supply air. See figure 21 for reheat refrigerant routing and figure 22 for standard cooling refrigerant routing.

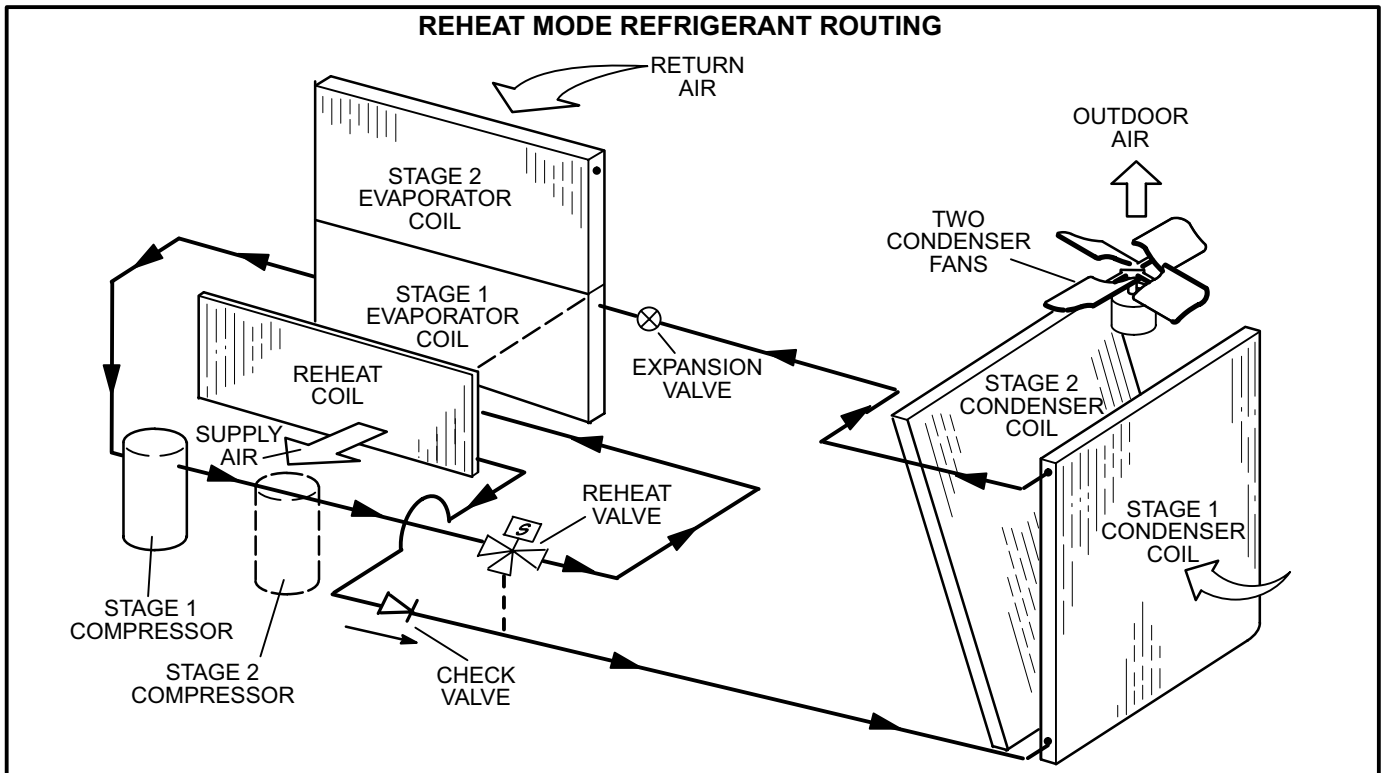

FIGURE 21

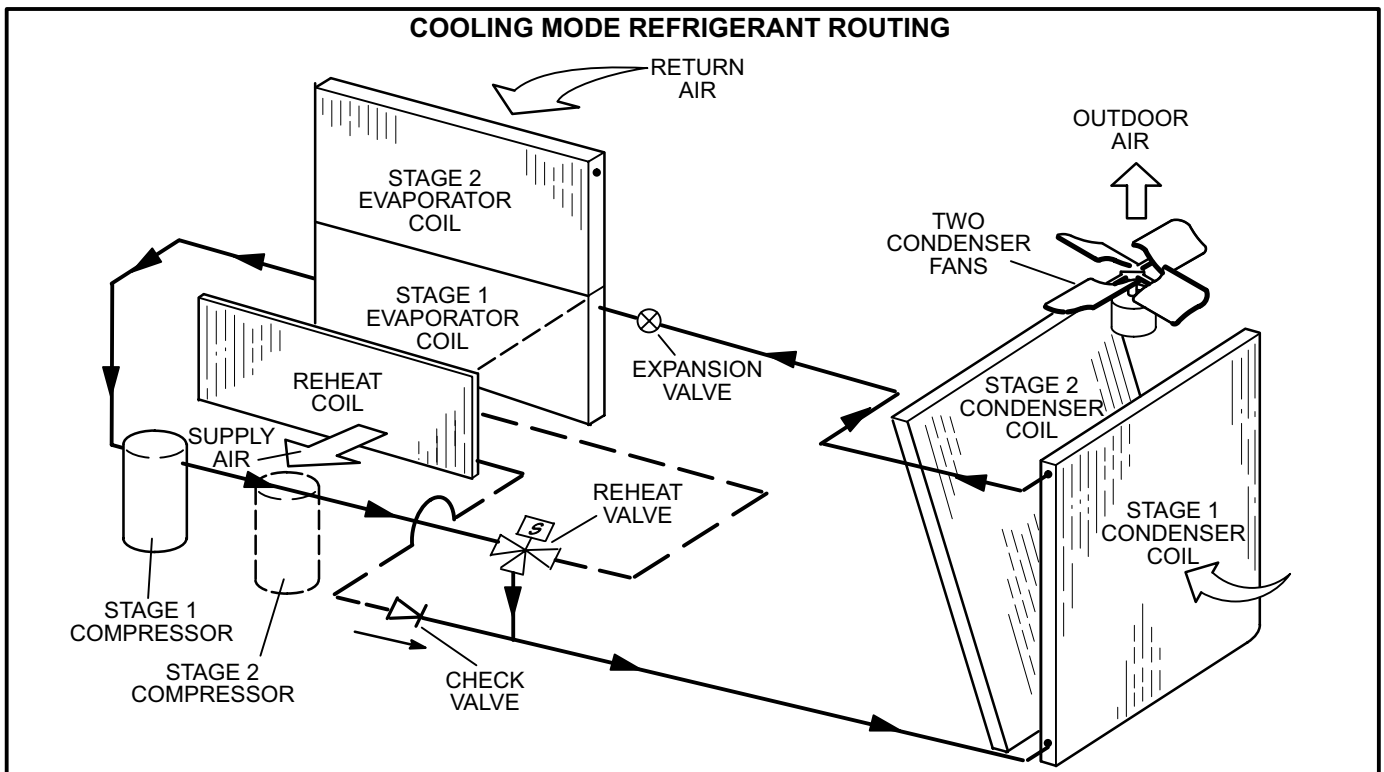

FIGURE 22

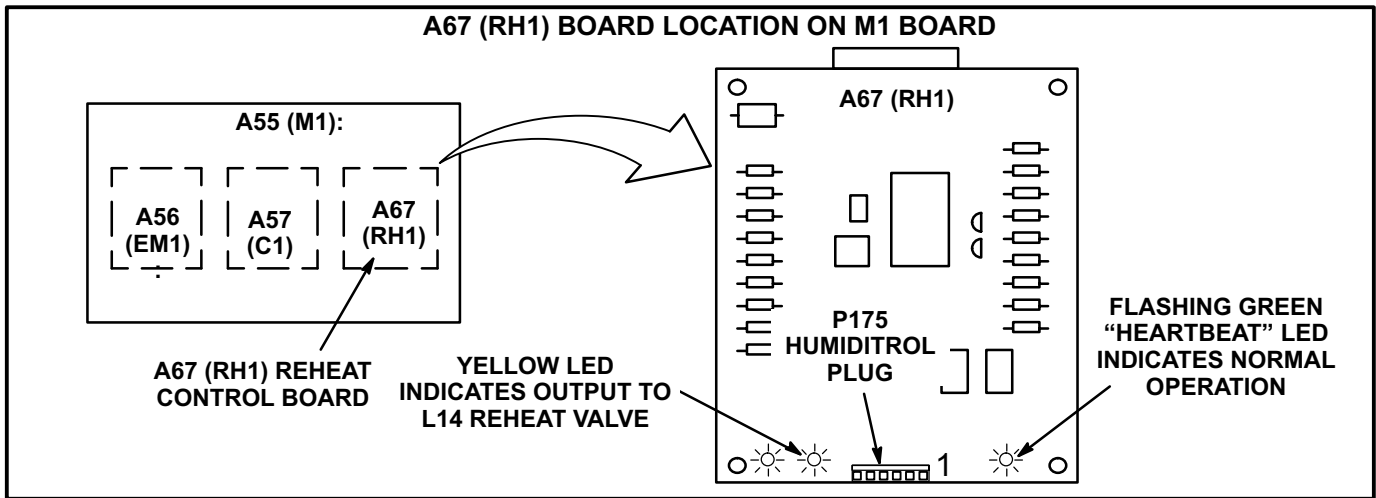

FIGURE 23

L14 Reheat Coil Solenoid Valve

When IMC board input (P114-10) indicates room conditions require dehumidification, L14 reheat valve is energized (RH1 board P175-3) and refrigerant is routed to the reheat coil.

RH1 Humiditrol Board

The RH1 add-on board is factory-installed in all Humiditrol units. RH1 is located on the M1 board as shown in figure 23.

Reheat Setpoint

Reheat is factory-set to energize when indoor relative humidity rises above 60% (default). Reheat will terminate when the indoor relative humidity falls 3% below setpoint, or 57% (default). The reheat setpoint can be adjusted by changing ECTO 4.25. A setting of 100% will disable reheat.

A91 Humidity Sensor

Install humidity sensor in the conditioned space according to instructions provided with sensor.

Relative humidity should correspond to the sensor (A91) output voltage listed in table 20. For example: if indoor air relative humidity is 80% ± 3%, the humidity sensor output should read 8.00VDC.

Check the sensor output annually for accuracy. Keep the air intake openings on the sensor clean and free of obstructions and debris.

Read Relative Humidity At IMC

Turn MODE DIP “TEMP” switch #4 “ON”. Display will alternately flash from readout to output. A single push on the pushbutton will toggle the readout upward from .0 to .7 incrementally. A double push will toggle the readout downward from .7 to .0 incrementally. Readout .7 indicates percent relative humidity.

Check-Out

Test Humiditrol operation using the following procedure.

- 1- Make sure RH sensor is wired as shown in figure 10 or 11.
- 2- Set IMC ECTO system mode parameter 6.01 to option 0 (default local thermostat mode).
- 3- Set IMC ECTO reheat setpoint parameter 4.25 to 0% relative humidity.
- 4- Jumper the following TB1 terminals:
 - 8&9 (occupied mode)
 - 6&3 (blower demand G)
 - 6&18 (Y1 cooling demand)

The blower, compressor 1 (reheat), and compressor 2 (cooling), should be operating. L14 LED on the A67 board should also be ON, indicating the reheat valve is energized.

- 5- Disconnect the jumper between TB1 terminals 6&18 (Y1) to end the cooling demand.
- 6- Press the IMC pushbutton to by-pass the compressor minimum run delay.

Compressor 2 (cooling) should de-energize, compressor 1 (reheat) should continue to operate, and L14 LED should still be ON.

- 7- Disconnect the jumper between TB1 terminals 8&9 (occupied mode).

Compressor 1 (reheat) should de-energize, L14 LED should go OFF, blower should still be energized.

- 8- **When check-out is complete, remove all jumpers, set ECTO 4.25 back to the proper humidity setpoint, and set ECTO 6.01 to the proper setting.**

TABLE 20

Relative Humidity (%RH ± 3%)	Sensor Output (VDC)
20	2.00
30	3.00
40	4.00
50	5.00
60	6.00
70	7.00
80	8.00
90	9.00

Default Reheat Operation

Humiditrol unit reheat control parameter 4.24 is factory-set to option 6. Reheat will operate as shown in table 21 once three conditions are met:

- 1- Blower must be operating.
- 2- System must be in occupied mode.
- 3- System must NOT be operating in heating mode.

IMPORTANT - Free cooling does not operate during reheat. Free cooling will operate as shown in the IMC manual.

Reheat Control Options

Reheat control parameter 4.24 can be set to other reheat control operating conditions as follows (see IMC manual):

ECTO 4.24 option 3 -

- 1- Blower must be operating.
- 2- System must be in occupied mode.
- 3- System must NOT be operating in heating mode.
- 4- One cooling demand is required if the unit has been in heating mode, the IMC has been reset, or at initial unit start-up.

ECTO 4.24 option 5 -

- 3- System must NOT be operating in heating mode.
- 4- One cooling demand is required if the unit has been in heating mode, the IMC has been reset, or at initial unit start-up.

ECTO 4.24 option 7 -

- 3- System must NOT be operating in heating mode.

Once the corresponding conditions are met in each mode, reheat will operate as shown in table 21.

TABLE 21

Reheat Operation - Two Cooling Stages - Default

T'stat and Humidity Demands	Operation
Reheat Only	Compressor 1 Reheat
Reheat & Y1	Compressor 1 Reheat & Compressor 2 Cooling*
Reheat & Y1 & Y2	Compressor 1 Cooling & Compressor 2 Cooling**

*If there is no reheat demand and outdoor air is suitable, free cooling will operate.

**If there is no reheat demand and outdoor air is suitable, free cooling and compressor 1 will operate.

Additional Cooling Stages

Units are shipped from the factory to provide two stages of cooling. (ECTO 5.04 option 2 and 6.01 option 0).

Three stages of cooling is available in zone sensor mode (ECTO 6.01 set to option 1, 2, or 3). Three stages of cooling is also available by installing a transfer relay and a three-stage thermostat; ECTO 5.04 must be set to option 3.

Service

The unit should be inspected once a year by a qualified service technician.

⚠ CAUTION

Label all wires prior to disconnection when servicing controls. Wiring errors can cause improper and dangerous operation. Verify proper operation after servicing.

⚠ WARNING

Product contains fiberglass wool. Disturbing the insulation in this product during installation, maintenance, or repair will expose you to fiberglass wool. Breathing this may cause lung cancer. (Fiberglass wool is known to the State of California to cause cancer.) Fiberglass wool may also cause respiratory, skin, and eye irritation. To reduce exposure to this substance or for further information, consult material safety data sheets available from address shown on unit nameplate or contact your supervisor.

A-Filters

Units are equipped with four 18 X 24 X 2" filters. Filters should be checked monthly and replaced when necessary with filters of like kind and size. Take note of air flow direction marking on filter frame when reinstalling filters. See figure 24.

NOTE-Filters must be U.L.C. certified or equivalent for use in Canada.

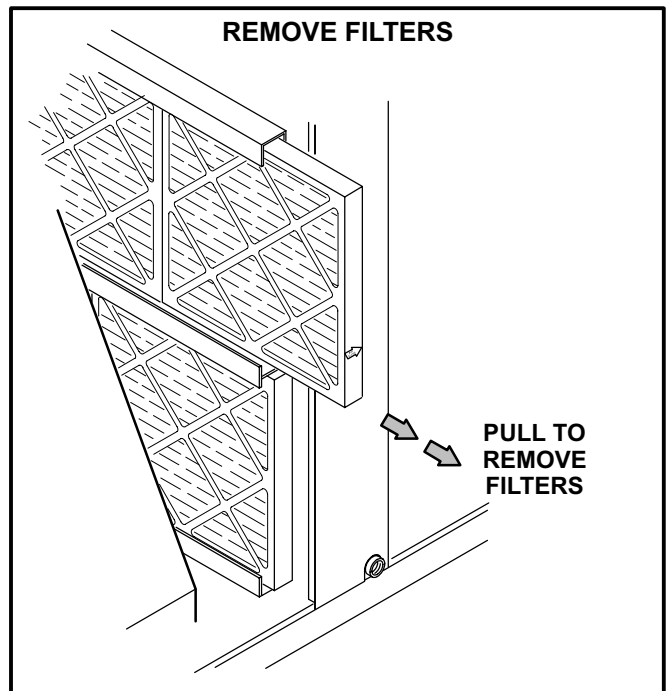

FIGURE 24

B-Lubrication

All motors are lubricated at the factory. No further lubrication is required.

C-Burners (LGA/LGC Units)

- 1- Periodically examine burner flames for proper appearance during the heating season.
- 2- Before each heating season examine the burners for any deposits or blockage which may have occurred.
- 3- Clean burners as follows:
 - a- Turn off both electrical power and gas supply to unit.
 - b- Open access panel to burner compartment.
 - c- Remove burner retaining bracket and lift burners from orifices.
 - d-Clean as necessary and replace burners. Refit retaining brackets. Make sure that burner heads line up correctly. Spark gap on ignition electrode must be properly set. Refer to Heating Adjustment section. Replace access panel.

⚠ WARNING



Danger of explosion. Can cause injury or death. Do not overtighten main burner mounting screws. Snug tighten only.

- e- Restore electrical power and gas supply. Follow lighting instructions attached to unit and use inspection port in access panel to check flame.

D-Combustion Air Inducer (LGA/LGC Units)

A combustion air proving switch checks combustion air inducer operation before allowing power to the gas controller. Gas controller will not operate if inducer is obstructed.

Under normal operating conditions, the combustion air inducer wheel should be checked and cleaned prior to the heating season. However, it should be examined periodically during the heating season to establish an ideal cleaning schedule. With power supply disconnected, the condition of the inducer wheel can be determined by looking through the vent opening.

Clean combustion air inducer as follows:

- 1- Shut off power supply and gas to unit.
- 2- Disconnect pressure switch air tubing from combustion air inducer port.
- 3- Remove and retain screws securing combustion air inducer to flue box. Remove and retain two screws from bracket supporting vent connector. See figure 25.
- 4- Clean inducer wheel blades with a small brush and wipe off any dust from housing. Clean accumulated dust from front of flue box cover.

- 5- Return combustion air inducer motor and vent connector to original location and secure with retained screws. It is recommended that the combustion air inducer gasket be replaced during reassembly.
- 6- Clean combustion air inlet louvers on heat access panel using a small brush.

E-Flue Passageway and Flue Box (LGA/LGC Units)

- 1- Remove combustion air inducer assembly as described in section D.
- 2- Remove flue box cover. Clean with a wire brush as required.
- 3- Remove flue baffle retaining bracket and pull tube baffles from heat exchanger tubes. Clean tubes and baffles with a wire brush.
- 4- Reinsert tube baffles, secure baffle retaining bracket, and reassemble the unit. The flue box cover gasket and combustion air inducer gasket should also be replaced during reassembly.

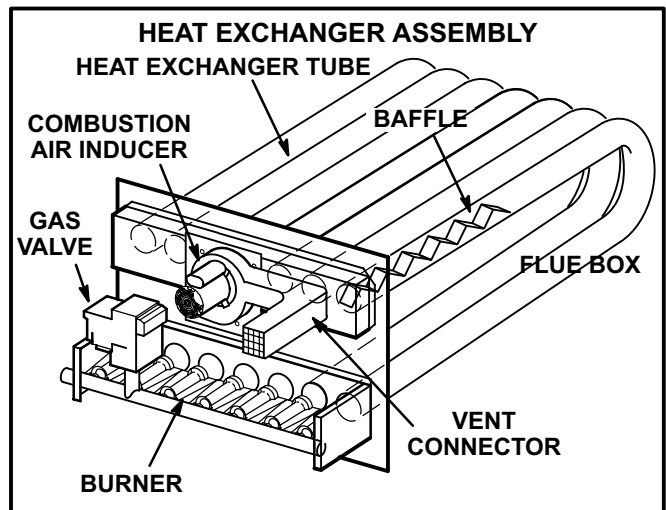

FIGURE 25

F-Evaporator Coil

Inspect and clean coil at beginning of each cooling season. Clean using mild detergent or commercial coil cleanser. Flush coil and condensate drain with water taking care not to get insulation, filters and return air ducts wet.

G-Condenser Coil

Clean condenser coil annually with detergent or commercial coil cleaner and inspect monthly during the cooling season. Access panels are provided on front and back of condenser section.

H-Supply Air Blower Wheel

Annually inspect supply air blower wheel for accumulated dirt or dust. Turn off power before attempting to remove access panel or to clean blower wheel.