

DMS4 AND RVZ1 MULTIZONE SYSTEMS

- application
- operation
- maintenance manual

LENNOX *Industries Inc.*

Price \$5.00

ROOFTOP UNITS
501,574M
8/81
Supersedes 501,292M and
501,342M

INTRODUCTION

This manual is written as a guide for sales, service and maintenance personnel involved in the operation and maintenance of the unit. We recommend all personnel utilize this manual to become familiar with the operation of the unit so basic service and maintenance can be capably performed.



TABLE OF CONTENTS

I - APPLICATION

| | |
|------------------------------|---------|
| A - ROOF MOUNTING FRAME..... | PAGE 2 |
| B - SUPPLY AIR SYSTEM..... | PAGE 4 |
| C - RETURN AIR SYSTEM..... | PAGE 9 |
| D - ZONE DISTRIBUTION..... | PAGE 10 |

II - GENERAL INFORMATION

| | |
|-----------------------------------------------|---------|
| A - BASIC SEQUENCE OF OPERATION..... | PAGE 13 |
| B - GENERAL SCHEMATIC WIRING INFORMATION..... | PAGE 18 |
| C - COMPONENT..... | PAGE 20 |
| D - START-UP AND PERFORMANCE CHECK LIST..... | PAGE 30 |
| E - PREVENTIVE MAINTENANCE GUIDE..... | PAGE 31 |

III - SYSTEM CONTROL

| | |
|------------------------------------------|---------|
| A - COMMAND AND MONITORING CONTROLS..... | PAGE 32 |
| B - FUNCTION CHARTS..... | PAGE 34 |
| C - TROUBLESHOOTING CHART..... | PAGE 38 |
| D - REMOTE CONTROL OPTIONS..... | PAGE 39 |

IV - HEATING

| | |
|-----------------------------------|---------|
| A - GAS HEAT..... | PAGE 42 |
| B - ELECTRIC HEAT..... | PAGE 49 |
| C - HOT WATER AND STEAM HEAT..... | PAGE 55 |

V - COOLING

| | |
|----------------------------------------|---------|
| A - POWER SAVER AND DISCRIMINATOR..... | PAGE 58 |
| B - REFRIGERANT COOLING..... | PAGE 61 |
| C - CHILLED WATER..... | PAGE 74 |

VI - BLOWERS

| | |
|------------------------------|---------|
| A - DMS4 BLOWER SECTION..... | PAGE 78 |
| B - RVZ1 BLOWER SECTION..... | PAGE 80 |

VII - ZONE CONTROL

| | |
|-----------------------------------|---------|
| A - GENERAL DAMPER OPERATION..... | PAGE 95 |
| B - PERFORMANCE CHECK..... | PAGE 96 |

VIII - FILTERS

| | |
|-----------------------------|---------|
| A - FILTER MAINTENANCE..... | PAGE 98 |
|-----------------------------|---------|

IX - SERVICE FLOW CHARTS

| | |
|---------------------------------------------------------------|----------|
| A - SERVICE FLOW CHART FOR INDOOR AND RETURN AIR BLOWERS..... | PAGE 101 |
| B - SERVICE FLOW CHART FOR HOT DECK OR HEATING SECTIONS..... | PAGE 102 |
| C - SERVICE FLOW CHART FOR COLD DECK OR COOLING SECTIONS..... | PAGE 103 |

PARTS ARRANGEMENT

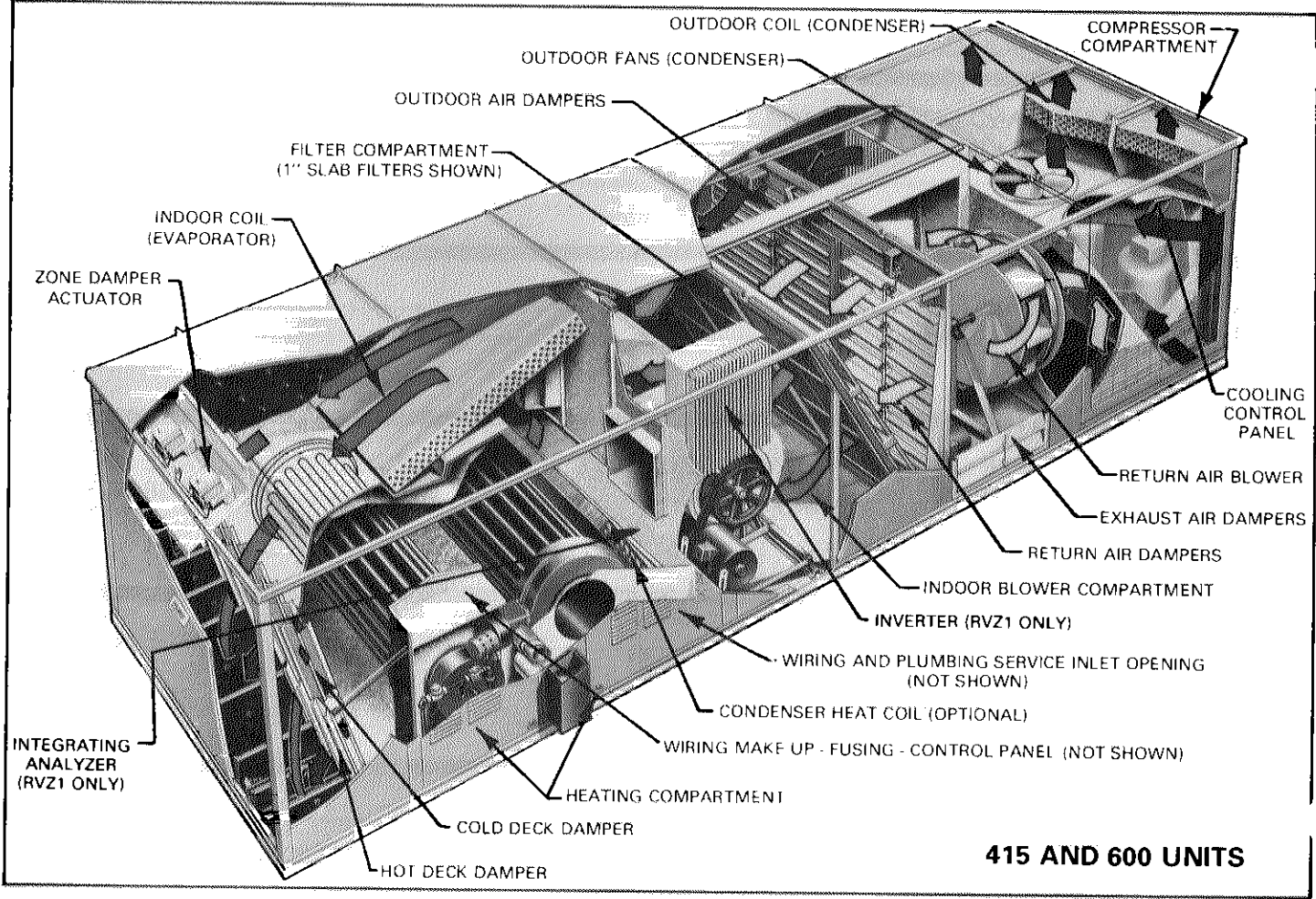
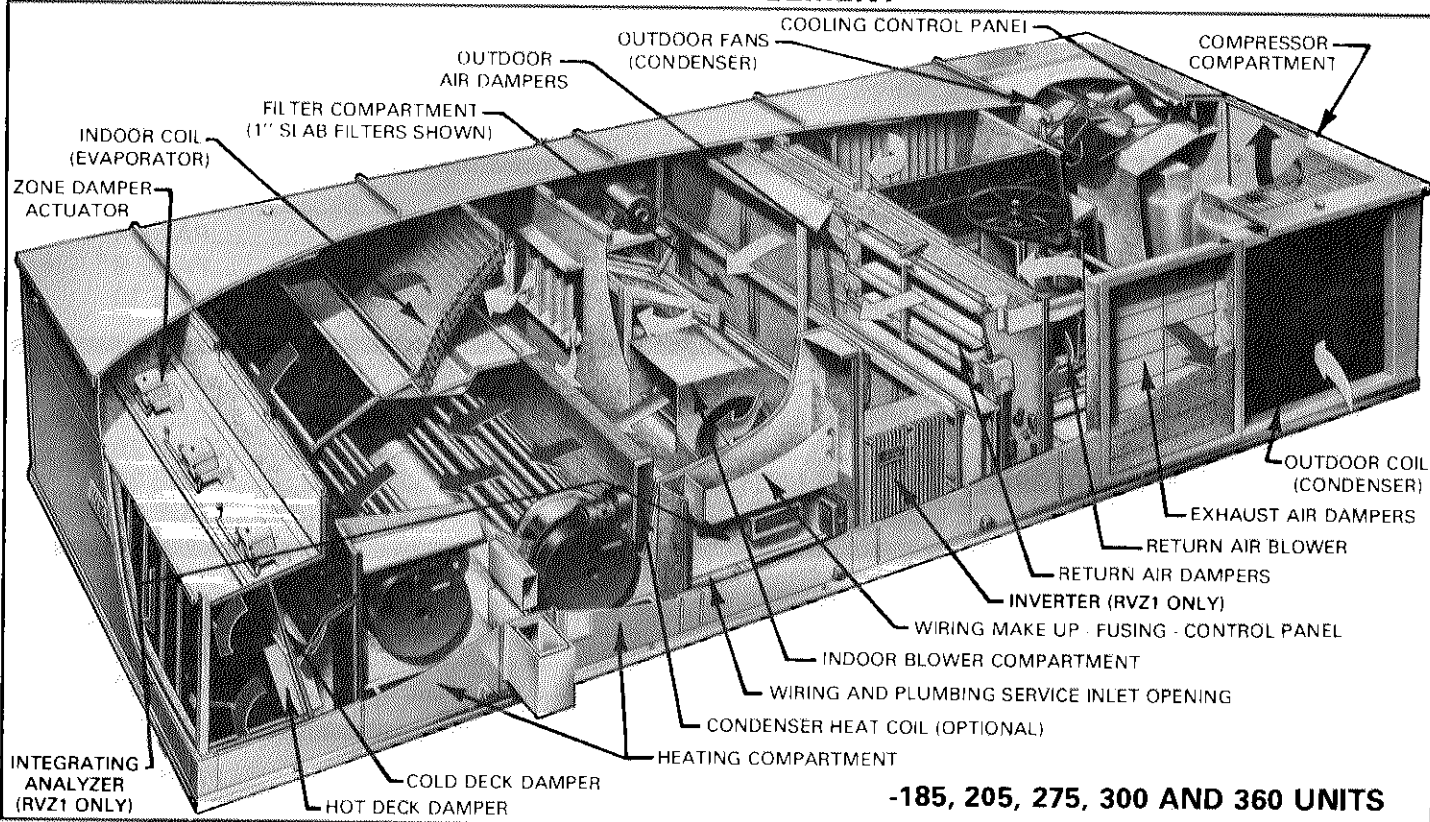

APPLICATION SECTION

This section lists fundamental guidelines and requirements when applying a multizone System.

APPLICATION

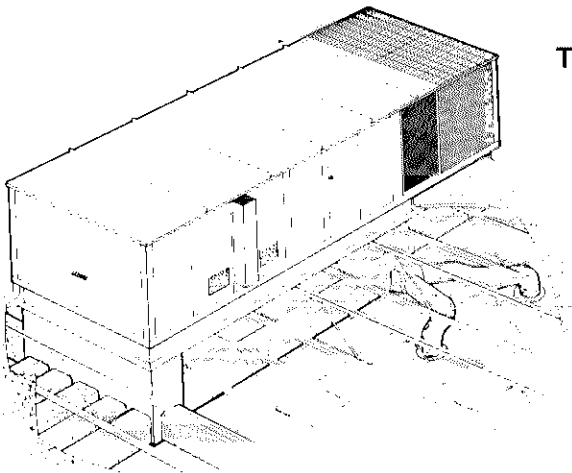

Zone distribution system.
Mixing dampers located at unit.

TYPICAL APPLICATIONS

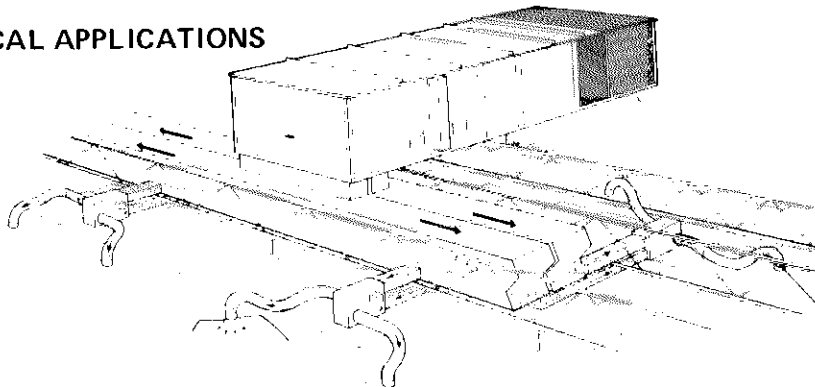

Double duct distribution system with zone damper boxes.
Mixing dampers remote from unit

I — RVZ1 APPLICATION INFORMATION

The application details of a Varizone unit, including the zone dampers can be summarized as follows:

- 1 - Each zone duct should be sized in the usual manner to accommodate maximum conditions for that zone. (This is the same as in a conventional multizone application.)
- 2 - Diffusers should be suitable for variable air volume operation, where varying inlet static pressure and flow rates may otherwise cause "dumping" during reduced air-flow. Such diffusers are commonly available. Undesirable stratification with heating is avoided by the capability to supply 100% of the design air volume.
- 3 - Select unit maximum CFM, external static pressure and cooling capacity based on "block" load requirements at cooling design conditions. Unit CFM will be less than the sum of the individual peak requirements. (Example - East and west zones will not peak at the same time.)
- 4 - The RVZ1 can provide constant air volume to an isolated critical zone where a separate unit is not practical. See page 97. On such a zone the duct should be sized for a pressure drop approximately 50% less than the VAV zones served by the same unit. An in-duct static pressure regulation device, set to maintain a static pressure

equal to that of the lowest blower speed, should be installed at the inlet of the constant volume duct. Figure 1 shows typical examples. This insures constant static pressure of that duct throughout the normal varying static pressure range of the RVZ1 unit. For instance, if the ducts of the system are sized for 0.1 inch of water column pressure drop per 100 feet of duct, a 1,000 CFM zone would require a 14 inch round duct. However, in case of a constant volume zone, a lower static pressure of 0.05 inch of water column drop would be needed, thus requiring a 16 inch round duct to supply the same 1,000 CFM.

- 5 - All Varizone Systems will operate more efficiently, and with greater stability, if they are sized with relatively low-pressure-drop duct systems.
- 6 - As with all variable air volume systems, it is necessary to evaluate the minimum ventilation requirements of the system. The RVZ1 provides maximum air flow to a given zone during peak heating requirements.
- 7 - It is recommended to operate the blower continuously during the night setback mode since it will automatically be reduced to its lowest operating speed. Continuous blower operating is particularly recommended where a smoke detection option is used.
- 8 - In accordance with ASHRAE Standard 90, to reduce electrical system distribution losses, it is recommended that an operating power supply of greater than 250 volts be used.

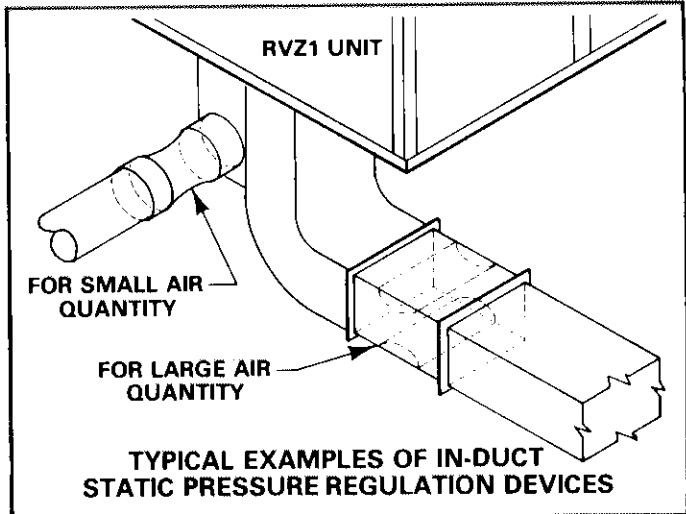

FIGURE 1

II - ROOF MOUNTING FRAME

Standard roof mounting frame is 14" (356 mm) galvanized steel that fits the perimeter of the unit. Frame is approved by the National Roofing Contractors Association (NRCA). Frame is shipped knocked down, and sections are assembled together with bolts and joint plates. Figure 2.

A - Frame Application and Location

Mounting frame can be installed directly on a roof deck having adequate structural strength or on roof supports under deck. When installing frame on support members under deck, the following support specifications apply:

- 1 - With joint plates bolted, the maximum frame span between supports is 5 feet (1.52 meters).
- 2 - With joint plates welded to the frame the maximum frame span is 16 feet (4.88 meters) and maximum cantilever is 9 feet (2.74 meters).
- 3 - A bolted joint plate cannot be included in a cantilever. If the frame

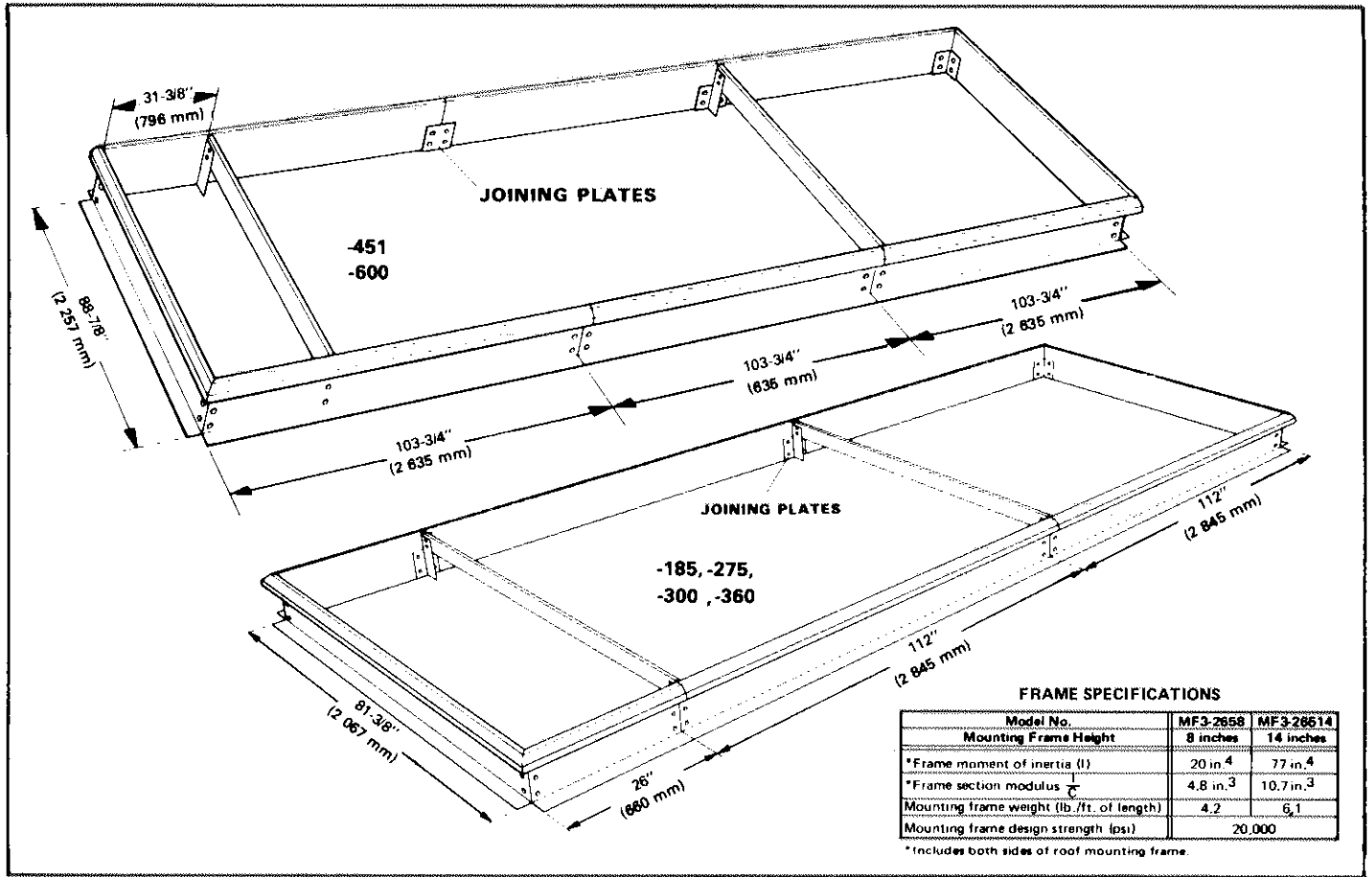

FIGURE 2

is cantilevered more than 6 feet (1.83 meters) the joint plate and frame closest to the overhang must be welded.

- 4 - There must be at least 32 linear inches (813 mm) of frame in contact with roof supports.
- 5 - Care must be taken to insure that openings for the supply plenum, wiring and plumbing service inlet are unobstructed.
- 6 - Refer to Figure 3 for service clearance requirements.
- 7 - To assure proper mating of the multizone unit to the roof mounting frame, it is mandatory that the frame be properly squared, all

sides straight, shimmed (if necessary) and secured to the roof structure.

- 8 - Maximum slope tolerance of the roof mounting frame (length only) is 1/8" per foot (10.8 mm per meter). The frame must be level side to side.

B - Curbing and Flashing

- 1 - The outside of the frame should be insulated with a rigid type insulation, preferably 2" (51 mm) thick. Do not use any combustible material for filling around frame.

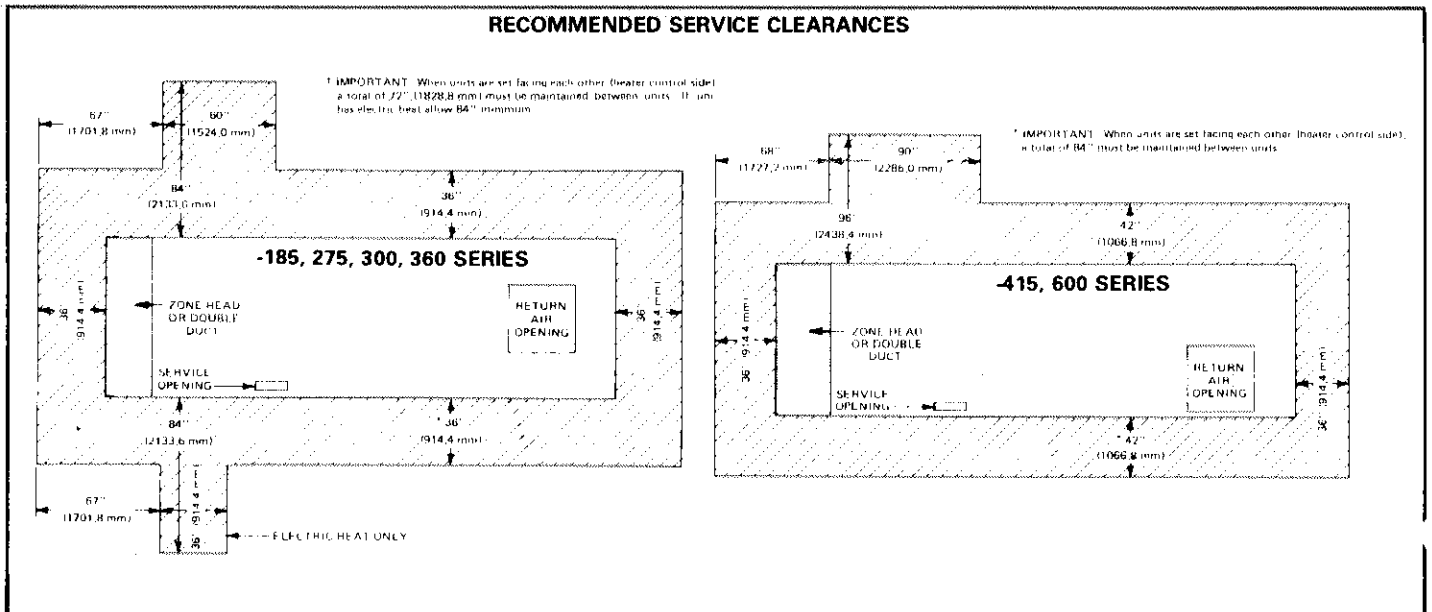

FIGURE 3

ROOF MOUNTING FRAME

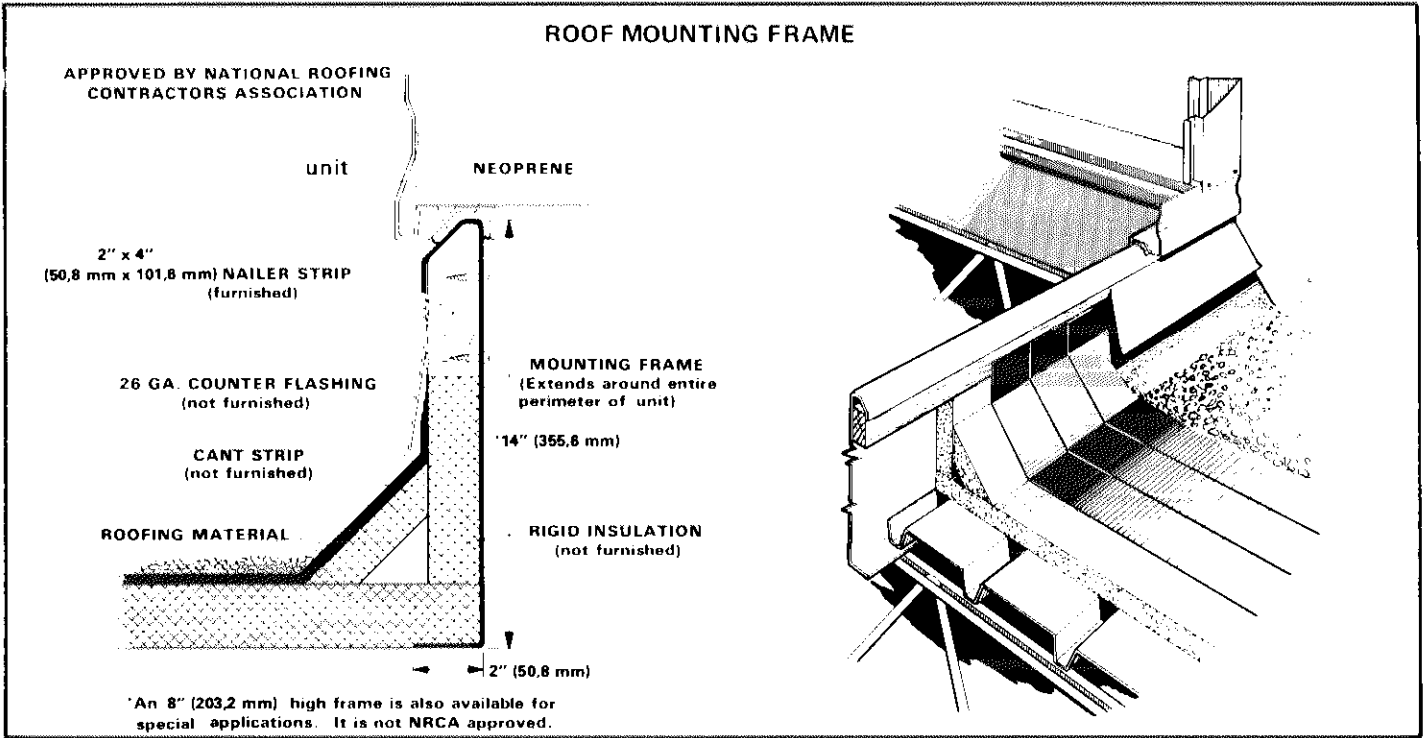

FIGURE 4

- 2 - Counter flash and seal around mounting frame using approved roofing methods. Refer to Figure 4.
- 3 - If a poured roof is used, (such as concrete) be sure inside of roof mounting frame is adequately braced to insure a square and level frame.

III - SUPPLY AIR SYSTEM

Supply air for the conditioned area is supplied from a zone head at the unit which is divided into individual zones or by a dual duct system with remote mixing boxes sized for individual zones. Unit zone head is available with either bottom or horizontal air discharge.

Each zone has hot and cold mixing dampers controlled by a room sensor.

A - Plenum Construction

Plenum must be constructed of galvanized steel (26 gauge minimum) with 3 lb. (1.36 kg.) by 1/2" (13 mm) thick fiberglass insulation applied to the inside of zone dividers. If 1-1/2 lb. (.68 kg.) density insulation is used, mechanical fasteners must be used to secure insulation to plenum. Refer to the following typical double duct and zone plenum illustrations for both horizontal (Figure 5) and bottom discharge air systems. (Figure 6).

NOTE - Refer to plenum installation instructions for detail dimensions of all plenums.

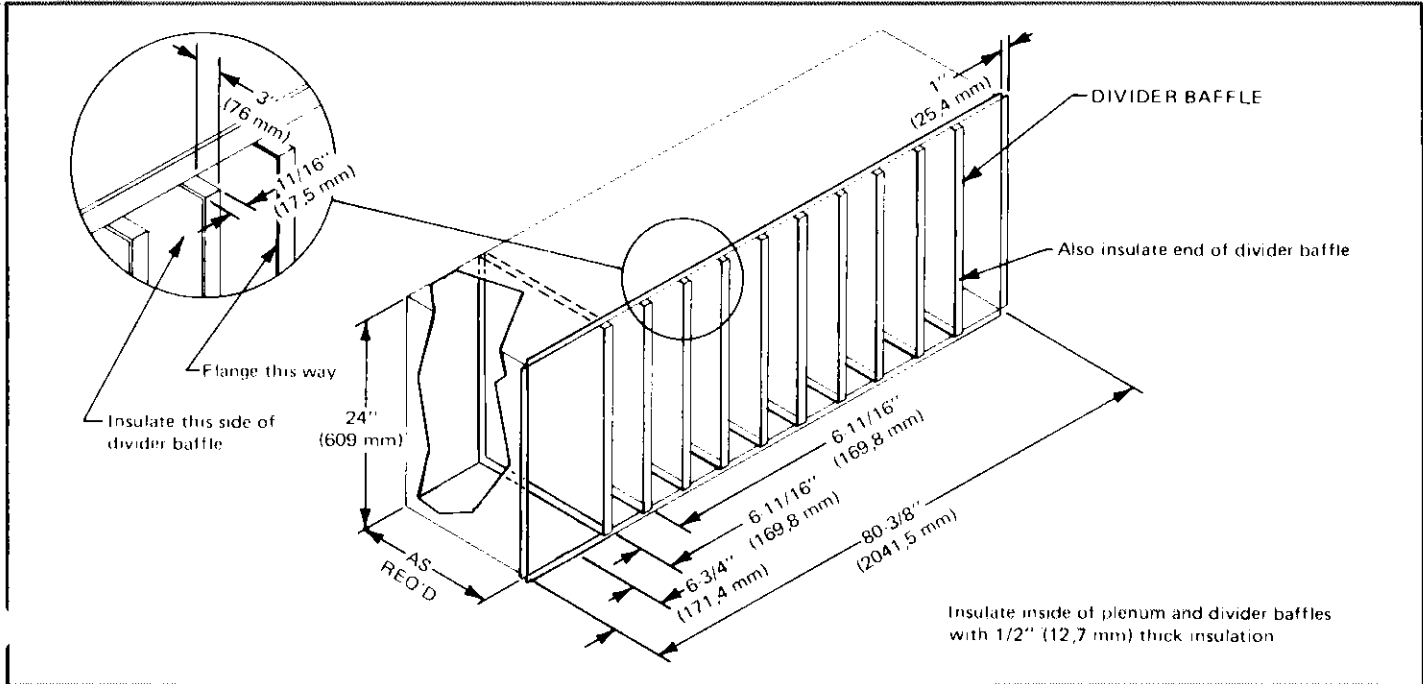
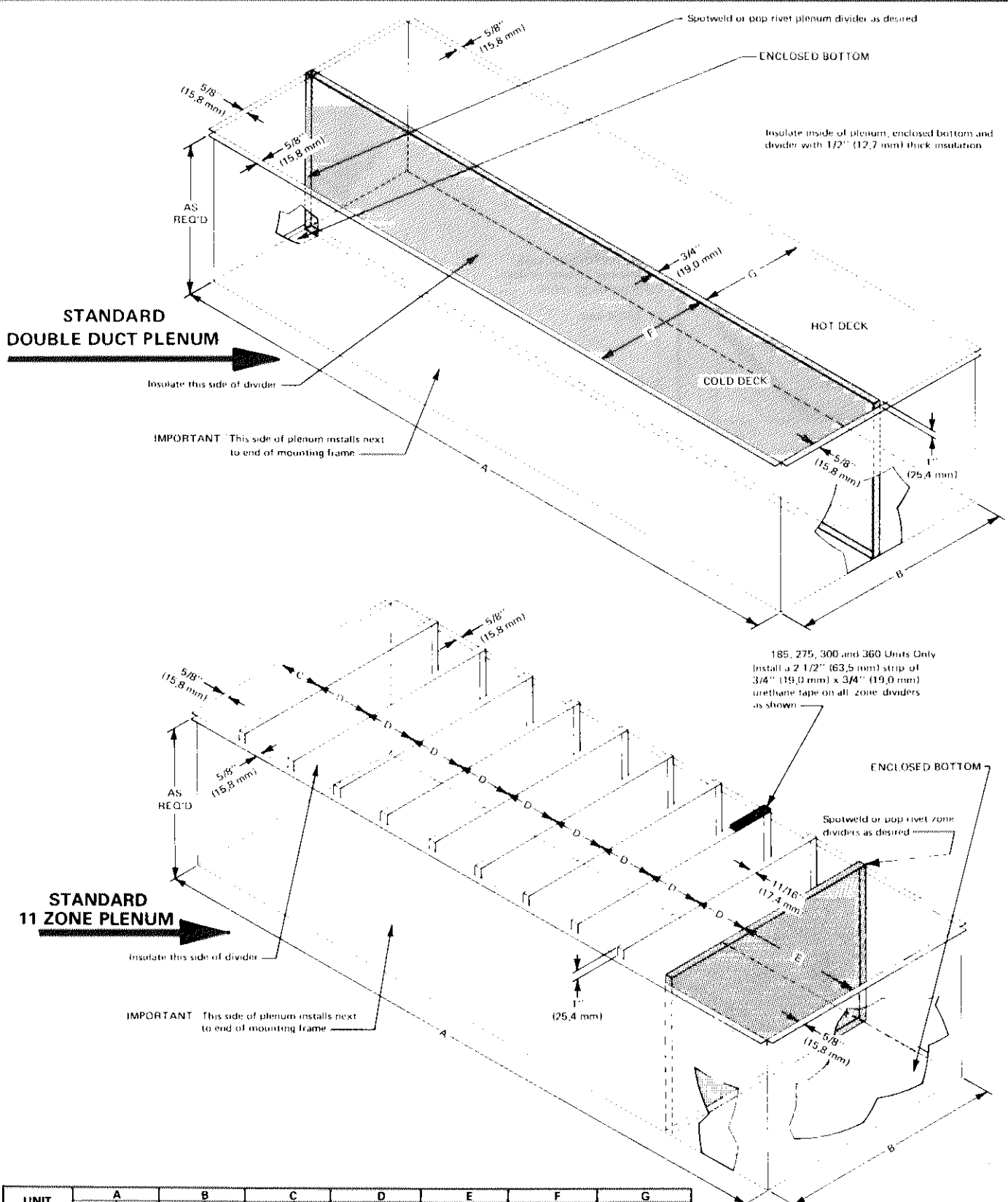

FIGURE 5



| UNIT | A | | B | | C | | D | | E | | F | | G | |
|------|--------|-------|--------|-----|--------|-----|---------|-----|--------|-----|----------|-----|----------|-----|
| | in | mm | in | mm | in | mm | in | mm | in | mm | in | mm | in | mm |
| 185 | | | | | | | | | | | | | | |
| 275 | | | | | | | | | | | | | | |
| -300 | 79 3/4 | 12154 | 24-3/8 | 619 | 6-7/16 | 164 | 6-11/16 | 170 | 13 1/8 | 333 | 11 13/16 | 300 | 11 13/16 | 300 |
| -360 | | | | | | | | | | | | | | |
| 415 | | | | | | | | | | | | | | |
| -600 | 87-1/4 | 2216 | 29-3/4 | 755 | 7 3/8 | 187 | 7 1/4 | 184 | 14 5/8 | 371 | 14 1/8 | 359 | 14-7/8 | 387 |

FIGURE 6

B - Installation (Bottom Discharge Plenum) Figure 8.

1 - Plenum support Z-bars must be provided to install the zone plenum in the roof mounting frame.

NOTE - If an AF6 or AF7 adaptor frame (required with gas fired equipment mounted on a combustible roof deck) the Z-bar supports are not used. Figure 8.

2 - The plenum must be installed with the plenum divider flanges to the right (as viewed from zone head end of the unit) to assure proper mating to zone dividers in unit. Refer to Figure 7.

3 - A field provided insulation seal must be installed to prevent air leakage from zone to zone. Fiberglass requirements are 1-1/2 lb.

(.68 kg) density by 1" by 2" (25 mm by 51 mm) by the length of the zone plenum. Refer to Figure 9.

C - Installation (Horizontal Discharge Plenum) Figure 10.

1 - Requires field fabricated sheet metal divider panel outlet mullion and filter pieces. Refer specifically to Lennox Horizontal Discharge Installation Instructions No. 501,237M for construction detail.

2 - Insulated bottom closure panel is factory installed in Multizone unit when unit is specified on order form for horizontal air discharge.

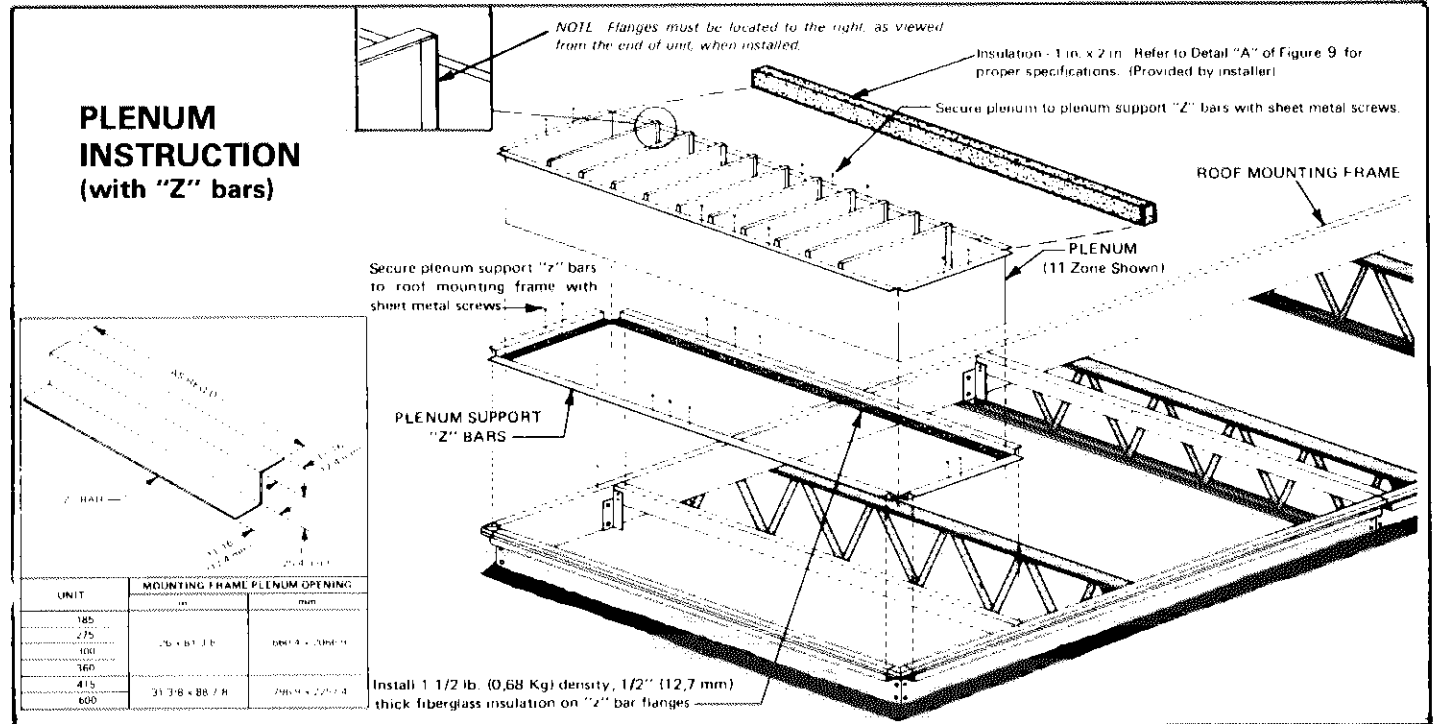

FIGURE 7

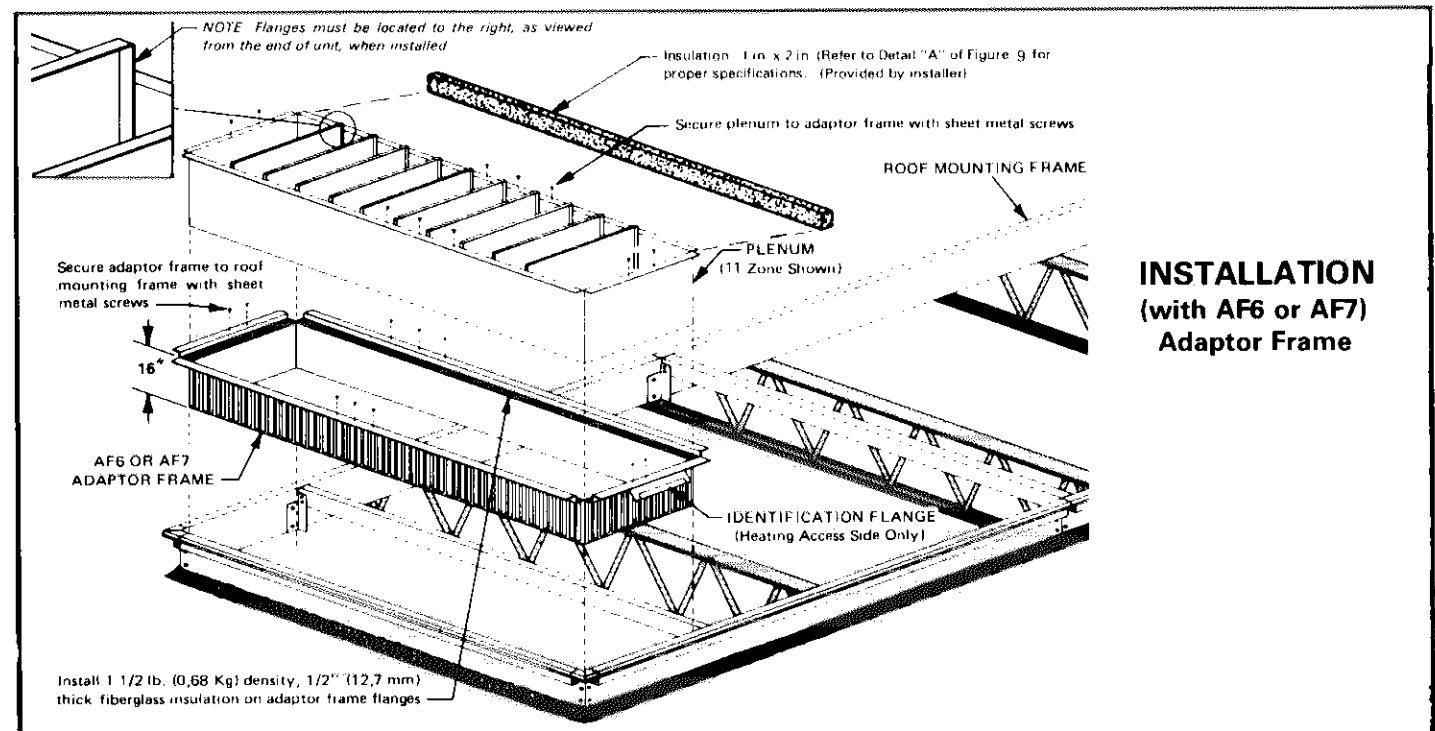

FIGURE 8

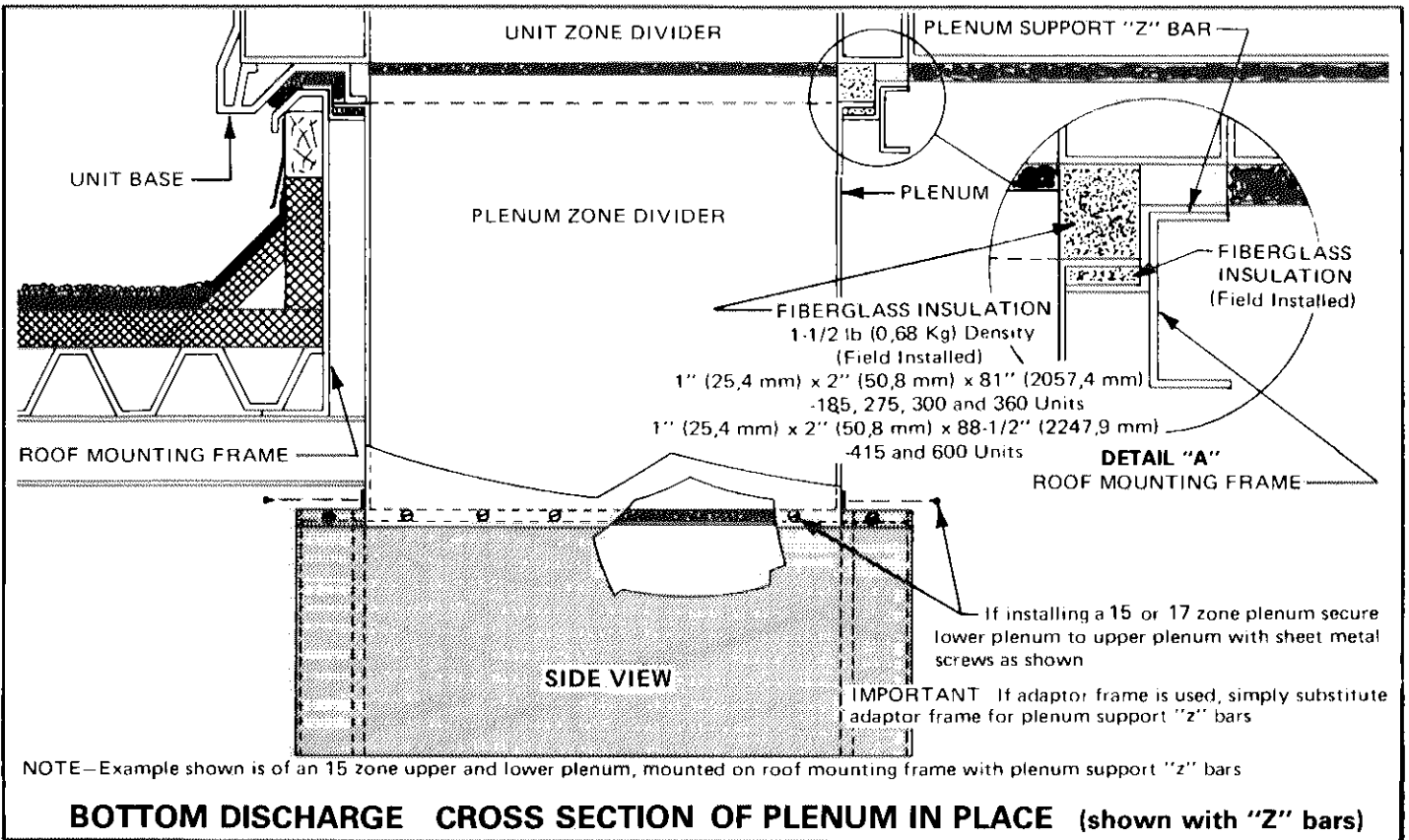

FIGURE 9

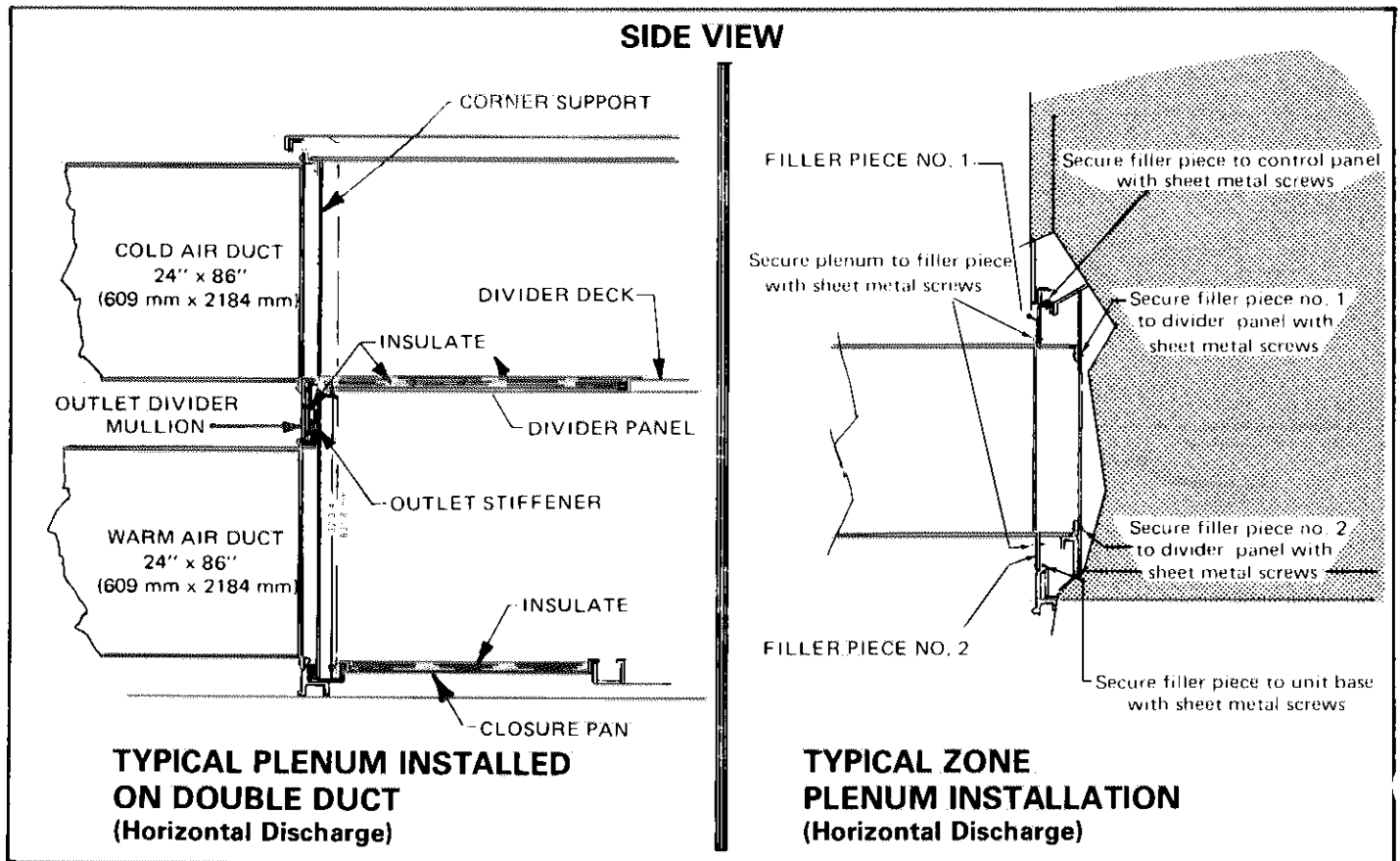

FIGURE 10

D - Remote Mixing Boxes

Remote zone mixing boxes are used with dual duct applications; 1 zone damper box is required per conditioned zone.

- 1 - The zone damper boxes may be installed in a false ceiling area, or any convenient indoor location that lends itself to proper air distribution. On installations with false ceiling areas, suspend damper box with 4 metal straps attached to each corner of the box
- 2 - The supply air from the hot and cold ducts are transitioned in the zone damper box by a splitter baffle. Refer to Figure 11 for the duct take offs in relationship to the splitter baffle.
- 3 - Use the following guidelines for running duct work from the zone damper box.
 - a - When running one duct from the zone box, remove splitter baffle. Refer to Figure 12.
 - b - When two ducts are run from the damper box, always take off opposite sides of the splitter baffle. Refer to Figure 12.
 - c - When 3 or more ducts are required, use an extended plenum and run individual ducts from plenum. Refer to Figure 12.

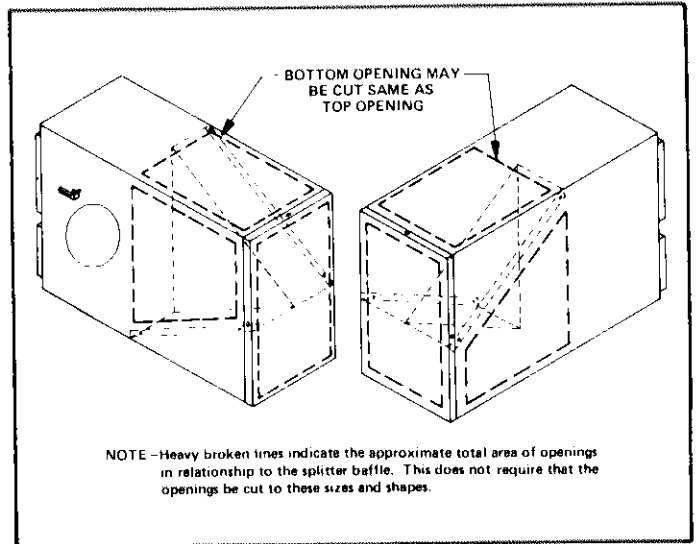

FIGURE 11

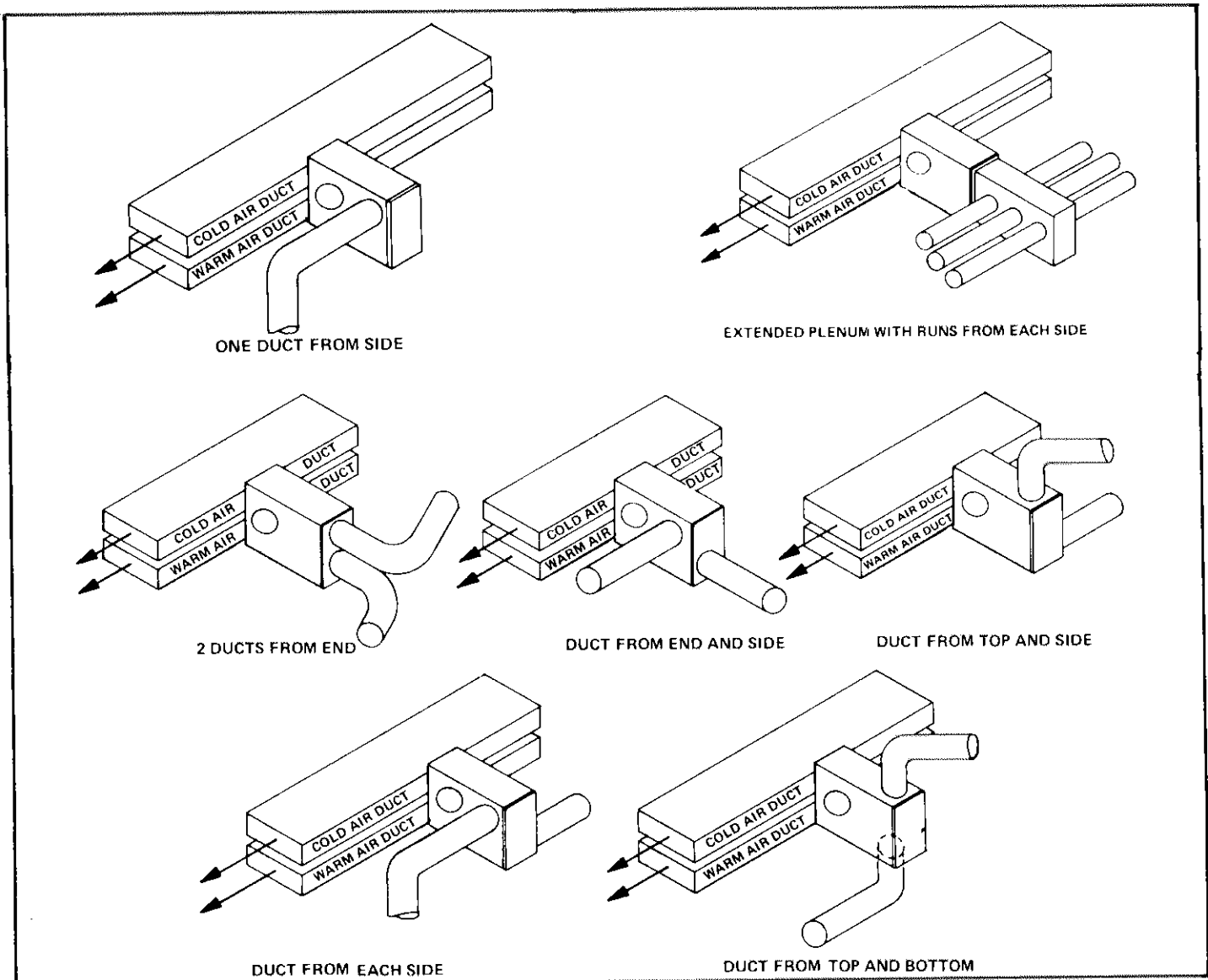

FIGURE 12

III - RETURN AIR SYSTEMS

Return air systems are generally either ducted or an open return air through a sandwich space above a false ceiling.

A - Ducted Return System

The ducted return air system offers the feature of lining the duct with insulation giving the ultimate in acoustical treatment.

B - Open Return System

The open plenum system eliminates the cost of return air ducts and is extremely flexible. In a building with relocatable interior walls it is much easier to change the location of a ceiling grille than reroute a ducted return air system.

Where any rooftop equipment utilizes the sandwich space for the return air system, a return air chamber such as illustrated in

Figure 13, should be connected to the air inlet opening of the rooftop equipment. This reduces air handling sound transmission through the thin false ceiling panels. It should be sized not to exceed 1500 FPM (7.6 m/s) return air velocity. It can be a fiberglass duct or fiberglass lined metal duct. It is recommended not to install a ceiling return air grille within 15 feet (4.57 meters) of the duct inlet.

C - Roof Mounting Frame as Plenum Chamber

The RMF3 Roof Mounting Frame may also be treated and used as a return air chamber to the Multizone unit. Depending on the CFM requirements, the 4" (102 mm) cross support members in the frame may need replacing with 3/4" (19 mm) rods. Refer to typical application in Figure 14.

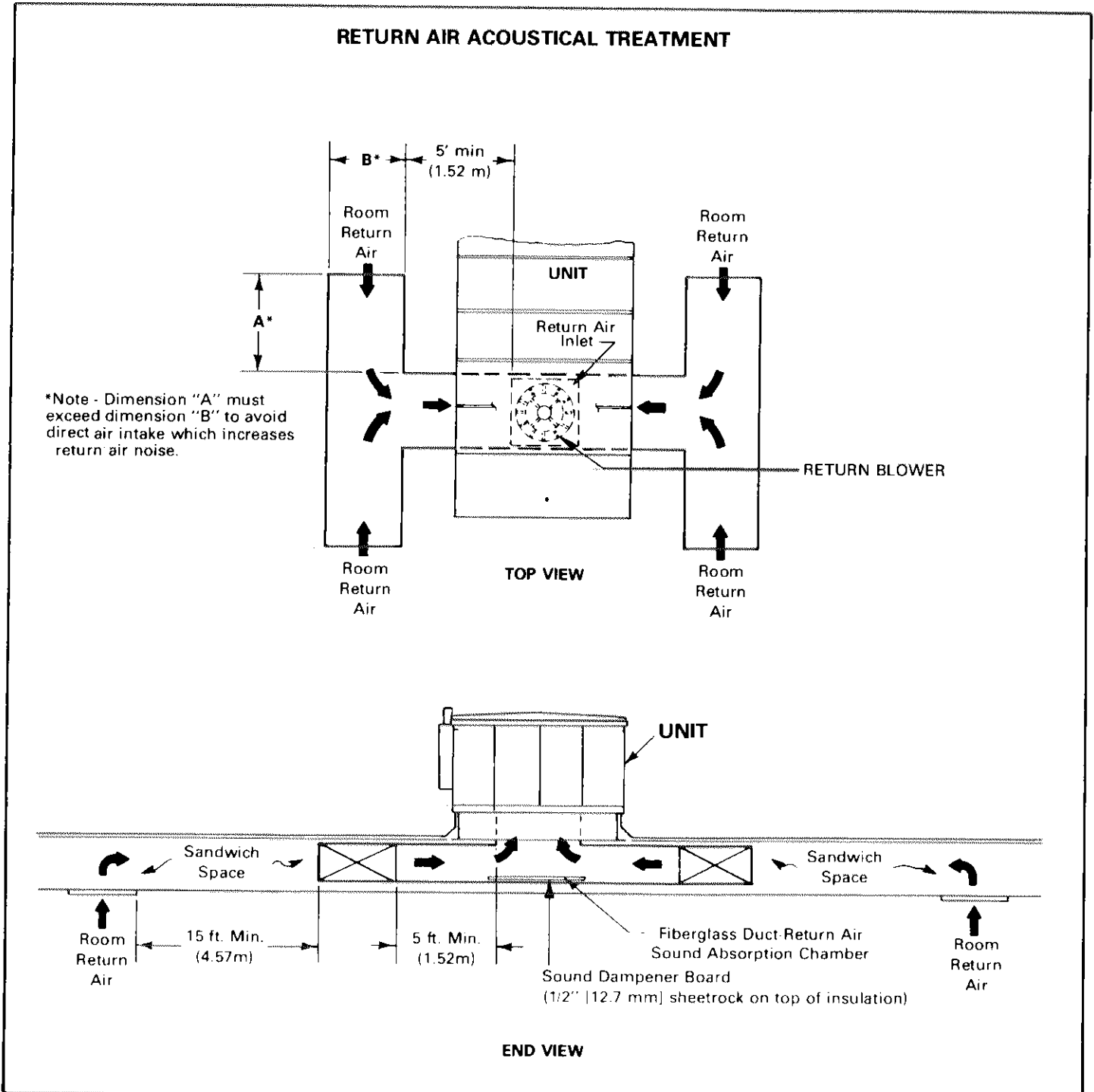

FIGURE 13

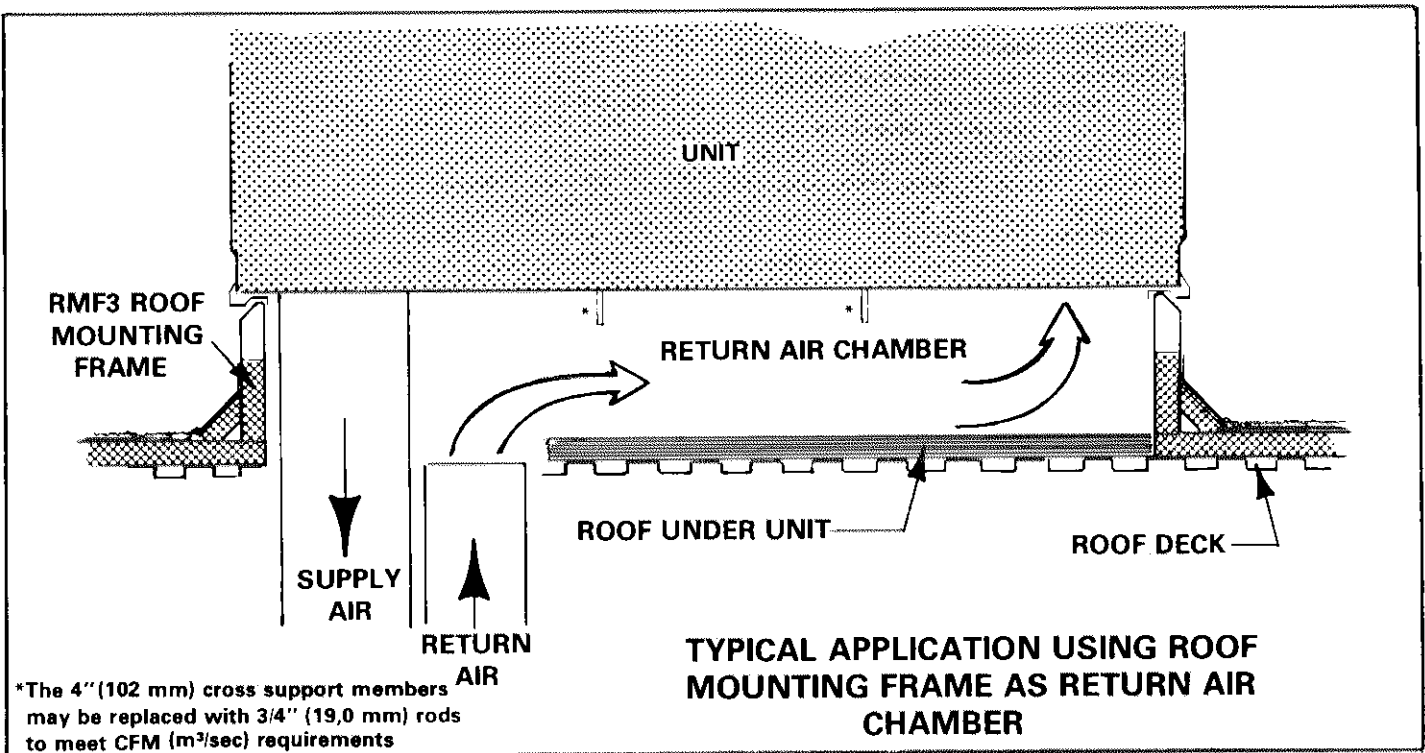

FIGURE 14

IV - ZONE DISTRIBUTION

Lennox multizone equipment is designed and engineered to deliver uniform air volume through the individual dampers in the zone head. However, due to different heating and cooling options available, the air pattern and volume may vary with certain options. Therefore, Lennox recommends the following guidelines to assure proper air volume and control to each of the zones. Refer to Figure 15.

- 1 - Whenever possible, combine the end damper with center dampers and use the combination on larger zones.
- 2 - For small or critical zones that require air from one or two damp-

- ers, use the center dampers to assure adequate zone control.
- 3 - Units with bottom air discharge have balancing dampers for each individual zone provided in the zone head. The dampers are located in each zone at the air discharge end of the unit at the bottom of the air outlet. These individual zone dampers must be adjusted to assure proper overall system balance. Units with horizontal air discharge and dual duct system do not have balancing dampers. We recommend balance dampers be installed in supply duct work to individual zones.

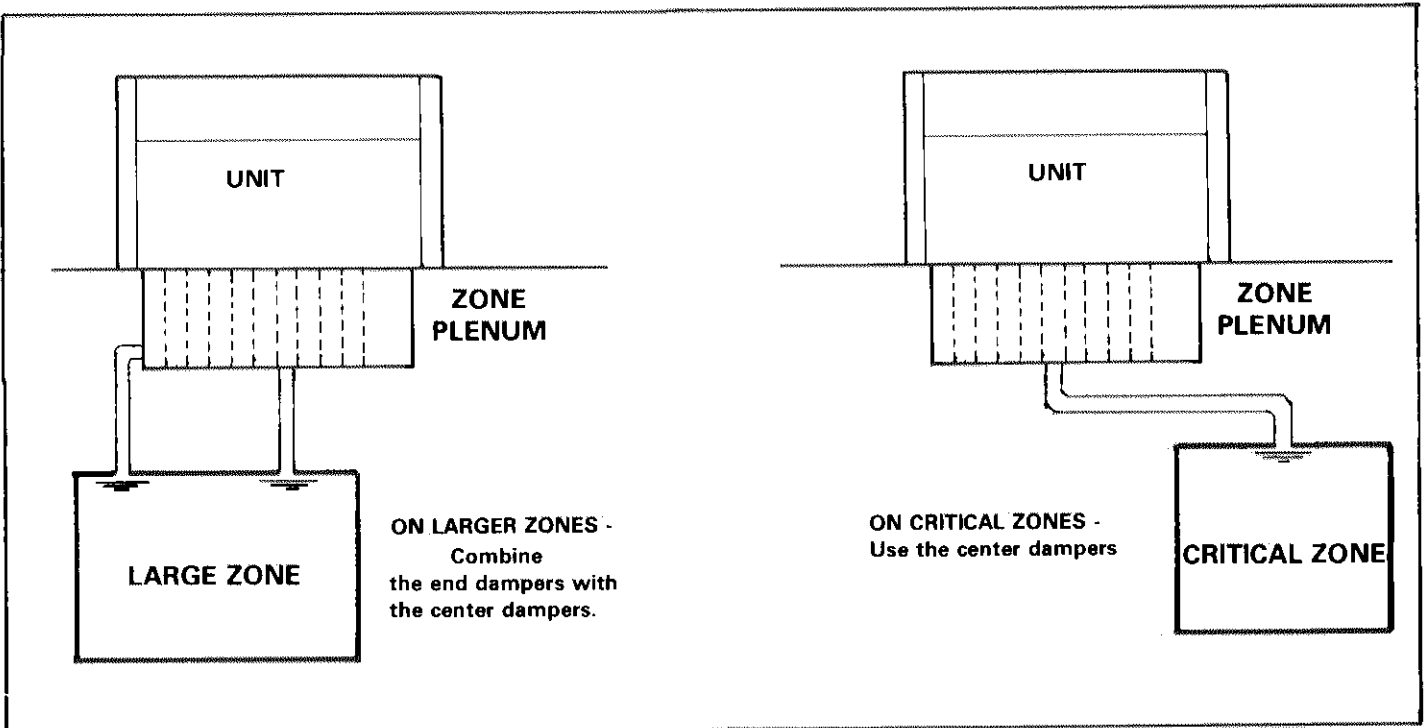

FIGURE 15

V - PREREQUISITES FOR ZONES

A zone is a separate area within the conditioned area which regulates its temperature by means of a room sensor. Zones must be properly divided to assure proper unit operation and control.

- 1 - Wall dividers or partitions do not constitute separate zones.
- 2 - A small zone adjacent to a large zone must keep its door closed or else the overall affect is the same as trying to make separate zones out of a partitioned area.
- 3 - Do not use 2 multizone units to control one zone.
- 4 - Locate equipment as near the center of the space as possible to reduce duct size and length and result in a better balanced system.

tem.

- 5 - Return air provisions must be made from each individual zone.
- 6 - An individual zone which needs an excessive amount of heat compared to the other zones, should use its own single zone unit.
- 7 - Only one room sensor should be used per zone. If a zone requires more CFM (m^3/sec) than one zone head damper can deliver, it is recommended two or more dampers be slaved (linked) together to satisfy zone requirements. Adjacent dampers in the zone head can be slaved together with mechanical linkage. Non-adjacent dampers can be electrically slaved together. **DO NOT USE MULTIPLE ROOM SENSORS IN THE SAME ZONE.** See Figure 16.

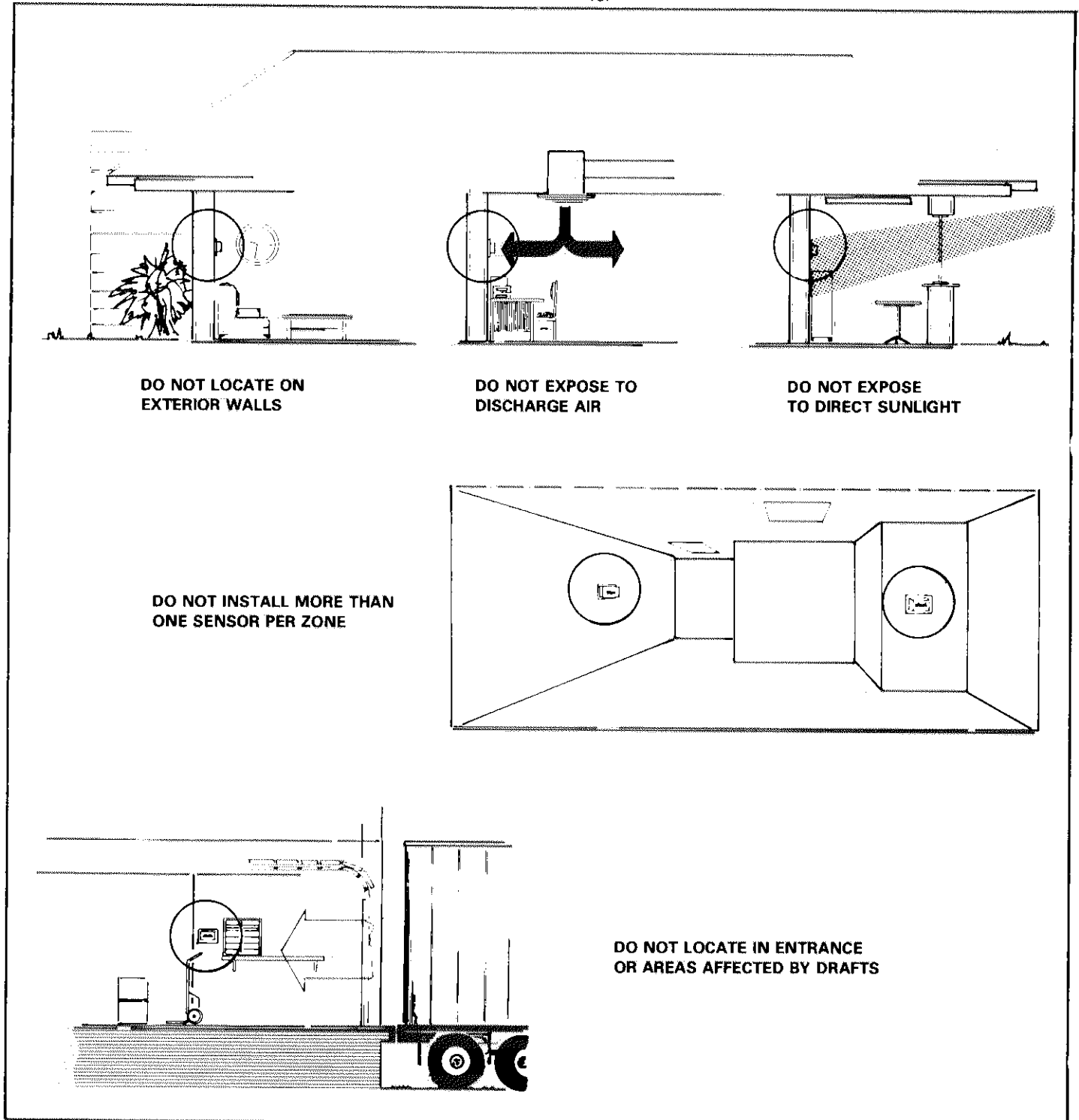

FIGURE 16

8 - In multiple unit installations, the following guidelines are recommended for mixing perimeter and core zones:

Maximum Load Diversity

For optimum energy efficiency, install a unit equipped with condenser heat and outside air discriminator in applications with maximum load diversity. See Figure 17. By intermixing perimeter and core zones, the heat rejected into the return air from core zones will be recirculated into the supply air stream. A cooling demand will initiate DX cooling and bring additional heat into the hot deck.

Minimize Load Diversity

Minimize load diversity in installations less condenser heat and outside air discriminator. If possible design system so perimeter zones go to one unit and core zones go to another. See Figure 17.

VI - ROOM SENSOR

On a typical heating/cooling day, the load demand swings from morning heating to midday cooling and back to late day heating. The room sensor controls the heating/cooling demand through the day within plus or minus 2 degrees of set point. The no-load band is adjustable from 3 to 30 degrees between heating and cooling demand. The unit coasts within the no-load band. Temperature control remains plus or minus 2 degrees at either end of the band. Refer to room temperature graph.

A - Installation

1 - Room sensor mounts on a standard 2" x 4" (51 mm x 102 mm)

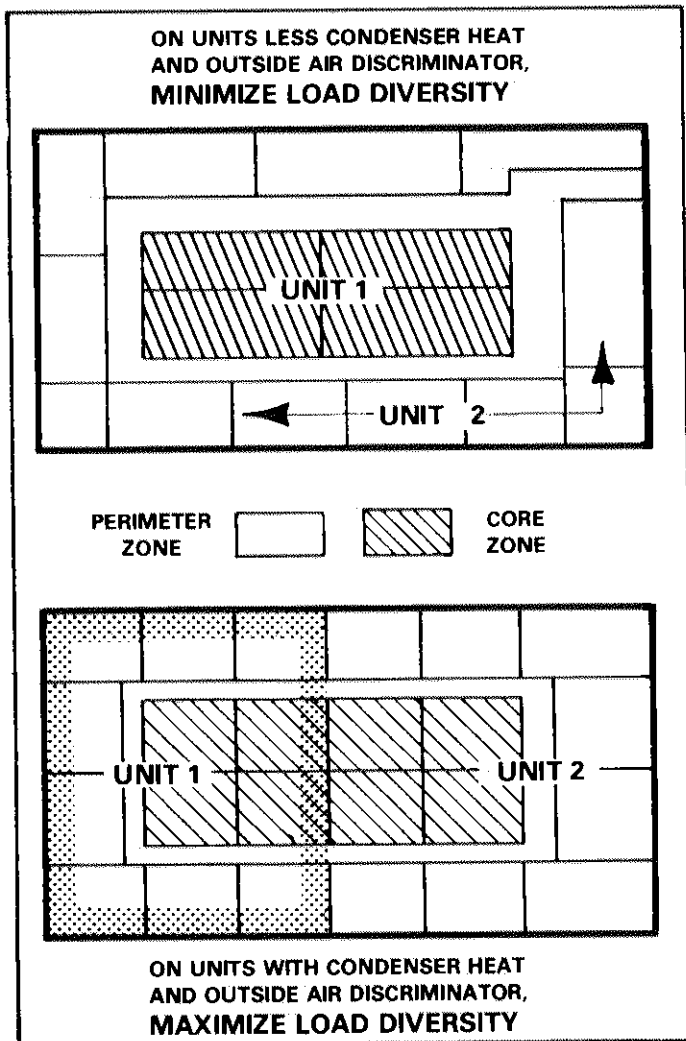

FIGURE 17

- 2 - Do not locate room sensor on an exterior wall, in an entryway, or in direct sunlight. See Figure 16.
- 3 - Make certain room sensor or sensors are located where they sample air in the occupied space for a particular zone, however, direct impingement by discharged air upon the room sensor should be avoided or minimized. See Figure 16.
- 4 - All room sensors should be maintained at approximately the same set point.

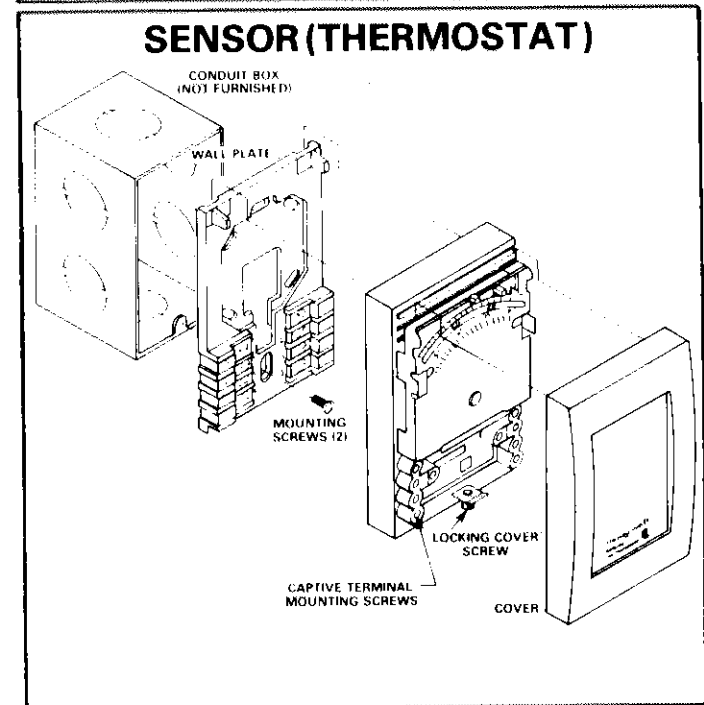
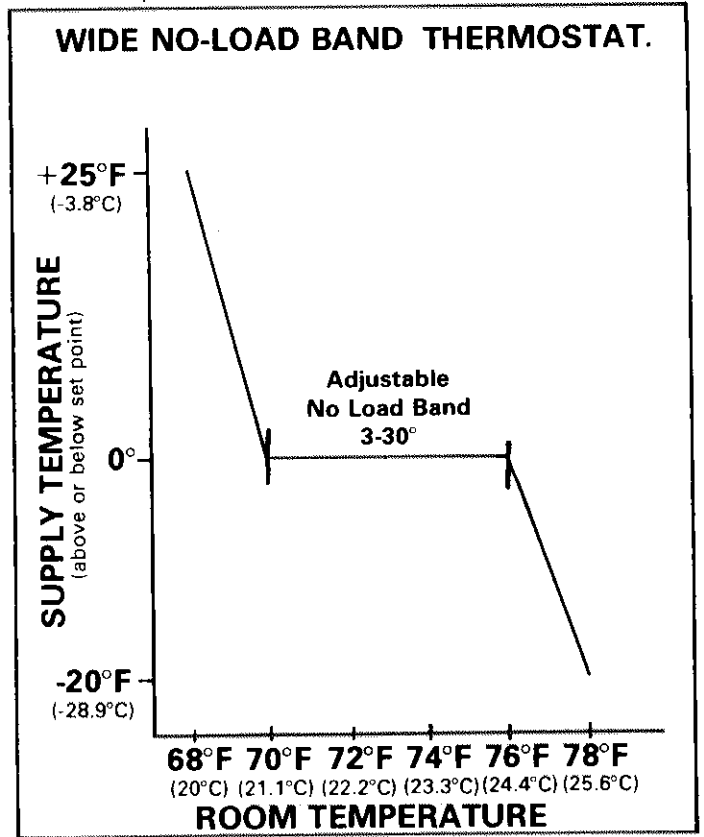

FIGURE 18

BASIC SEQUENCE OF OPERATION

I - BLOWER OPERATION

A - DMS4 Operation

- 1 - The indoor blower (B3) runs continuously under normal operation. The nite setback controls (optional) cycle the blower in response to heating demands during night operation. When heat demand is satisfied, the fan control (S6) allows blower to run until the excess heat dissipates from heat exchanger (gas heat only).
- 2 - The return air blower (B4 - optional) runs whenever the indoor blower is operating.
- 3 - Fire protection thermostats (S24 & S25) are located in the return air compartment and blower compartment. Thermostats terminate all unit operation at temperatures above setting.
- 4 - All other systems are dependent upon the blower operation. The sail switch (S31), located in the indoor blower air stream, senses a blower failure and shuts down all systems within the unit.
- 5 - With the presence of smoke, the smoke detection system (optional) terminates heating and cooling functions and provides 4 options of controlling blower and damper operation. See Figure 19.

Option 1 - "Shutdown"

- a - Supply blower stops.
- b - Return blower stops.
- c - Outside dampers close.
- d - Return dampers close.

Option 2 - "Exhaust"

- a - Supply blower stops.
- b - Return blower continues to run.
- c - Outside dampers close.
- d - Return dampers close.

Option 3 - "Intake"

- a - Supply blower continues to run.
- b - Return blower stops.
- c - Outside dampers open.
- d - Return dampers close.

Option 4 - "Intake and Exhaust"

- a - Supply blower continues to run.
- b - Return blower continues to run.
- c - Outside dampers open.
- d - Return dampers close.

Upon power failure or during nite setback conditions, the blowers stop and the return and outside dampers close. A remote smoke detector test station simulates smoke conditions to check performance of smoke detectors.

When the smoke detector(s) are reset, a time delay relay (DL7) in the blower circuit allows time for both dampers to open before supply and return blowers begin operation. A direct acting actuator (B9) drives the outside dampers while a reverse acting actuator (B10) drives the return air dampers.

B - RVZ1 Operation

- 1 - During normal operation the indoor blower motor (B3) runs continuously. The blower speed is determined by the A12 integrating analyzer and inverter (A8). If the unit has optional night setback but does not have smoke detectors, the blower motor cycles in response to heating demands during night operation. When the heating demand is satisfied, the fan control (S6) allows blower to run until the heat dissipates from heat exchanger (gas heat only). If the unit has both night setback and smoke detectors, the blower motor operates in two modes:
 - a - Day Operation — The blower motor runs at the speed dictated by the integrating analyzer.
 - b - Night Operation — Without a heating demand the motor continues to run, but the speed is determined by the night blower control (R1). With a heating demand the blower motor speed is again dictated by the integrating analyzer. These provisions allow the utilization of smoke detection during periods of night setback. Refer to Page 81 for additional information on the night blower control.
- 2 - The return air blower (B4 - optional) runs whenever the indoor blower is operating.
- 3 - Fire protection thermostats (S24 & S25) are located in the return air compartment and blower compartment. Thermostats terminate all unit operation at temperatures above setting.
- 4 - All other systems are dependent upon the blower operation. The blower proving switch (S31), located in the indoor blower airstream, senses a blower failure and shuts down all systems within the unit.
- 5 - With the presence of smoke, the smoke detection system (op-

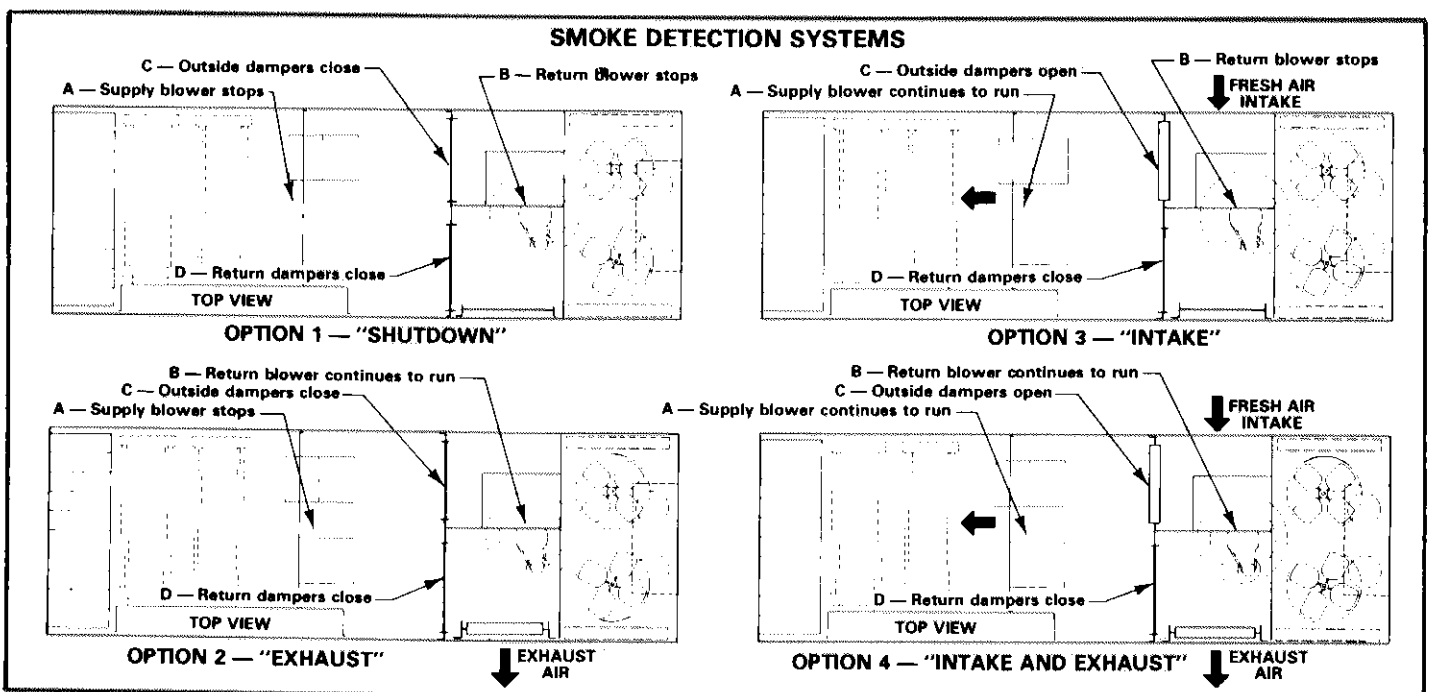

FIGURE 19

tional) terminates heating and cooling functions and provides four options of controlling blower and damper operation. See Figure 19.

Option 1 - "Shutdown"

- a - Supply blower stops.
- b - Return blower stops.
- c - Outside dampers close.
- d - Return dampers close.

Option 2 - "Exhaust"

- a - Supply blower stops.
- b - Return blower continues to run.
- c - Outside dampers close.
- d - Return dampers close.

Option 3 - "Intake"

- a - Supply blower continues to run.
- b - Return blower stops.
- c - Outside dampers open.
- d - Return dampers close.

Option 4 "Intake and Exhaust"

- a - Supply blower continues to run.
- b - Return blower continues to run.
- c - Outside dampers open.
- d - Return dampers close.

Upon power failure or during nite setback conditions, the return and outside dampers close. A remote smoke detector test station simulates smoke conditions to check performance of smoke detectors. A direct acting actuator (B9) drives the outside dampers while a reverse acting actuator (B10) drives the return air dampers.

II - THE LENNOX ELECTRONIC ENERGY SAVING SYSTEM

Each unit is equipped with a solid-state control system which cycles to unit to match its output to the load requirements. The control has two functions:

- 1 - To modulate zone dampers to provide conditioned supply air that satisfies the heating or cooling demands in each zone without override.
- 2 - To maintain hot and cold deck temperatures in the unit that satisfy the requirements of the zone with the largest heating load and the zone with the largest cooling load.

A - Zone Damper Controls

1 - DMS4 Zone Damper Control

Two air temperature sensors are used for each zone — one located in the conditioned space (A4 room sensor) and one mounted in the supply duct (RT4 discharge sensor). An electronic circuit compares the temperatures at room sensor and discharge air sensor to control the position of zone dampers. See Figure 20.

As the room temperature changes from the room sensor setpoint, the zone dampers will move to satisfy the demand. On a change in discharge air temperature, the zone damper will reposition in anticipation of the effect on room temperature.

If the conditioned zone requires more CFM than a particular damper opening can deliver, two or more dampers must be linked together to provide the needed CFM. Adjacent dampers can be slaved together using mechanical linkage. Non-adjacent dampers can be electrically slaved together. Although several dampers may be linked together, they still constitute one zone and are consequently controlled by one room sensor. Refer to "Electronic Zone Control" on page 95 for additional information on slaving dampers.

Three zone damper actuators are available:

- a - ZC16 Direct Acting - Actuator modulates in response to the variable voltage signal transmitted by the demands of the room sensor and discharge sensor.

- b - ZC15 Pneumatic - This actuator is controlled by a pneumatic space thermostat.

In addition the unit may be applied to a dual duct system with remote mixing boxes using the ZC8 direct acting or ZC7 pneumatic actuators.

2 - RVZ1 Zone Damper Control

Two air temperature sensors are used for each zone — one located in the conditioned space (A4 room sensor) and one mounted in the supply duct (RT4 discharge sensor). An electronic circuit compares the temperatures at room sensor and discharge air sensor to control the position of zone dampers. See Figure 20.

The zone dampers in the Varizone are designed so the hot and cold damper blades operate independently. A magnetic/spring overdrive mechanism will allow one blade to remain at closed or at minimum position while the other is opening. The minimum position is adjustable from zero to 45 degrees. This feature minimizes air mixing between the two decks, thus allowing treated air to go to the zones that require it.

As the room temperature changes from the room sensor set point, the zone dampers will move to satisfy the demand. On a change in discharge air temperature, the zone damper will reposition in anticipation of the effect on room temperature.

If the conditioned zone requires more CFM than a particular damper opening can deliver, two or more dampers must be linked together to provide the needed CFM. Adjacent dampers can be slaved together using mechanical linkage. Non-adjacent dampers can be electrically slaved together. Only three dampers may be mechanically linked to one actuator. If more than 3 dampers are required for a zone, use 2 or more actuators and slave electrically. Although several dampers may be linked together, they still constitute one zone and are consequently controlled by one room sensor. Refer to "Electronic Zone Control" on page 95 for additional information on slaving dampers.

Two zone control options are available:

- a - ZC17 Zone Control System - Actuator modulates in response to the variable voltage signal transmitted by the demands of the room sensor and discharge sensor.
- b - ZC8 - This actuator is used with remote mixing boxes for dual duct applications.

B - Hot And Cold Deck Controls

The A9 load analyzer module cycles the unit in response to the zone with the greatest heating demand and the zone with the greatest cooling demand. Any zone can generate these demands. See Figure 20. If no zone has a demand of sufficient magnitude to actuate either the heating or cooling functions, the system will coast with only the blowers running.

Overriding controls monitor cold and hot deck temperatures to protect unit from problem zones (a zone which transmits a constant heating or cooling demand).

III - VARIABLE AIR (RVZ1 ONLY)

In addition to zone temperature control, the RVZ1 incorporates energy conservation features which lower the watt consumption of indoor blower motor and return air blower motor (if used). These controls regulate blower motor speed in proportion to zone demands. The A12 integrating analyzer receives the zone signals from the room sensors. It analyzes these signals to determine the units air requirements and then transmits a DC volt blower command signal to the inverter. The inverter responds to this signal and changes blower motor RPM correspondingly. The A12 has a minimum speed adjustment which is factory set at 45% of full air. Figure 21 illustrates the blower command signal.

If individual zones require a constant air volume, the RVZ1 zone dampers can be field adjusted to provide the desired amount of air flow.

For a detailed explanation of the blower operation, refer to "BLOWERS" on page 76.

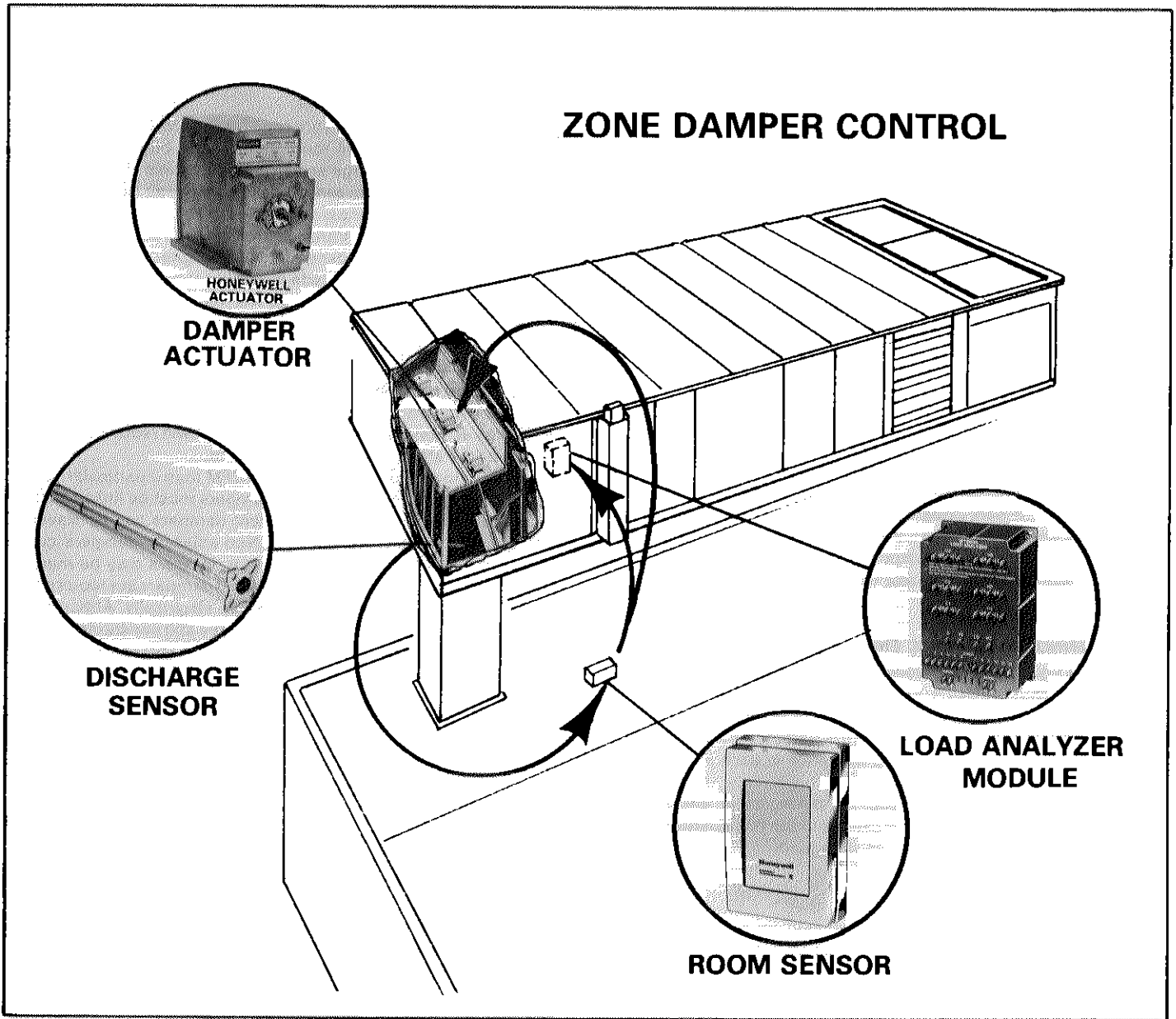

FIGURE 20

III - CONDENSER HEAT

The condenser heat option is used in conjunction with Outside-Air-Discriminator and Power Saver. The condenser heat coil within the hot deck gives off heat from the No. 1 refrigerant circuit whenever compressor 1 is running and there is a heating demand. The function chart in each respective heating section illustrate staging of condenser heat. The "Refrigerant Cooling" section on page 59 explains condenser heat operation. The following table lists the available heat per size unit.

| CONDENSER HEAT CAPACITY | | |
|-------------------------|----------------|-------------------|
| Size Unit | Btuh Available | Kcal/hr Available |
| -185 | | |
| -205 | 95,000 | 23 940 |
| -275 | 125,000 | 31 500 |
| -300 | | |
| -360 | 155,000 | 39 060 |
| -415 | 125,000 | 31 500 |
| -600 | 155,000 | 39 060 |

IV - GAS HEAT

Gas heat capacities range from 275,000 through 850,000 Btuh input.

- 1 - On a heating demand, the combustion air blower is energized to provide a prepurge period to clear combustion chamber. A time delay brings on the first stage of gas heat after the prepurge period has elapsed.
- 2 - An additional heat demand brings on the second stage of gas heat after 5 minute delay.
- 3 - A power burner, with individual electronic safety controls that monitor flame conditions, is incorporated on each heat exchanger used. The A7 analog hot deck limit control and (2) back-up high limit controls shut down burner(s) at excessive hot deck temperatures.

V - ELECTRIC HEAT

Electric heaters range in size from 45 KW to 150 KW. Each element has 15 KW capacity. A five switch A10 electric heat sequencer controls stepping of elements to satisfy the heating demand. Lockout relays balance the load between electric elements and compressors to prevent overloading the main switch.

RVZ1 BLOWER MOTOR CONTROL

INTEGRATING ANALYZER

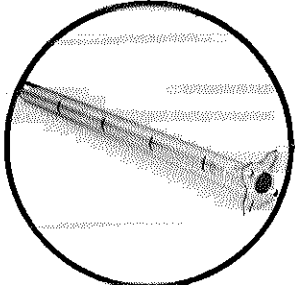
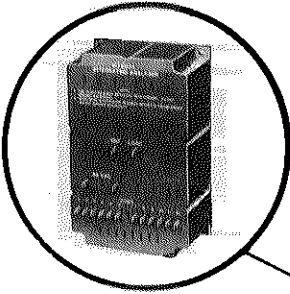

DISCHARGE SENSOR

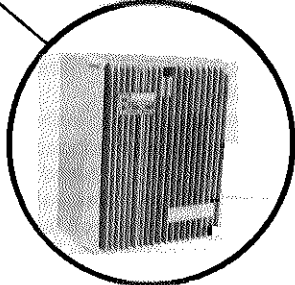

INVERTER

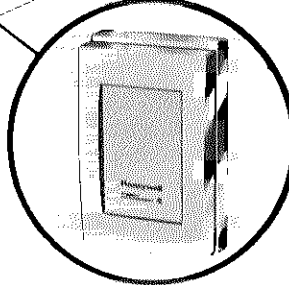

ROOM SENSOR

DISCHARGE SENSOR

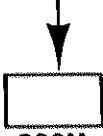
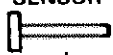

ROOM SENSOR

ZONE SIGNAL

INTEGRATING ANALYZER

BLOWER COMMAND SIGNAL

INVERTER



BLOWER MOTOR(S)

POWER CIRCUIT

FIGURE 21

VI - HOT WATER AND STEAM HEAT

The motorized valve controls flow through the hot water and steam coils.

- 1 - A heating demand will open valve.
 - a - The steam coil uses a two way valve.
 - b - The hot water coil uses a three way valve to either direct hot water to coil or by-pass coil.
 - c - An auxiliary circulator pump (optional) continuously circulates water through coil.
- 2 - Both coils are equipped with air bleed valves. The hot water coil has a drain valve.

- 3 - The freeze protection thermostat (S40) monitors the coil manifold temperature and opens the valve at a set point to prevent coil freezing.

VII - POWER SAVER

- 1 - The Power Saver consists of outside and return air dampers which are linked together. These dampers open and close in reverse relationship to each other. A cooling demand modulates the outside dampers open. If the fresh air cannot satisfy the demand, mechanical cooling will be engaged.

- 2 - The Power Saver actuator has a minimum air adjustment to set for a specific amount of fresh air.
- 3 - The enthalpy control (S18) senses both temperature and humidity or the heat content of the outdoor air. When the heat content rises above control set point, the outside dampers close to minimum position.
- 4 - The Outside-Air-Discriminator (optional) holds the outside dampers at minimum position at a given switch point in the heating mode.
- 5 - The morning warm-up control (S16) holds outside dampers at closed position until the return air temperature has risen above the set point.
- 6 - On nite setback, the outside air dampers are in the fully closed position.
- 7 - The sandstorm switch (S17-optional) is a manual switch which closes the outdoor dampers.

VIII - REFRIGERANT COOLING

The operating sequence and cooling functions vary according to the size of the unit.

- 1 - The Lennox L6 compressor has two speeds which run at 1,800 RPM at low speed and 3,600 RPM at hi speed. Each L6 compressor has a positive interlock between speeds to prevent both speeds from being energized simultaneously. There is a time delay between speeds.
- 2 - Each compressor has an individual refrigerant circuit. The No. 1 refrigerant circuit is equipped with a hot gas by-pass valve for conditions requiring reduced capacity. As the suction pressure drops below the hot gas valve set point, the valve opens to prevent an evaporator coil freeze-up.
-300/360/600 units are also equipped with an additional solenoid

valve (L1) which only permits hot gas by-pass when the L6 compressor is on low speed.

- 3 - Each compressor is protected by a high gas pressure switch (S32), low gas pressure switch (S34), ambient thermostat (S33) and a crankcase heater. In addition 8 and 11 ton compressors use internal cutout thermostats (S35) and overload relays while the 15 ton compressors use inwinding thermistors with a protection module (A1).
- 4 - The compressor monitor (S38) locks out compressors whenever the outdoor air falls below set point.
- 5 - The evaporator low limit (S41) control locks out compressors when cold deck temperature drops below set point.
- 6 - The following list matches compressor usage to unit size.
 - a - 185 uses two L2, 8 ton compressors.
 - b - 205 uses two L2, 8 ton compressors but has a larger evaporator for 19 tons of cooling.
 - c - 275 uses two L2, 11 ton compressors.
 - d - 300 uses one L6, 15 ton compressor and one L2, 11 ton compressor.
 - e - 360 uses one L6, 15 ton compressor and one L2, 15 ton compressor.
 - f - 415 uses three L2, 11 ton compressors.
 - g - 600 uses one L6, 15 ton compressor and two L2, 15 ton compressors.

IX - CHILLED WATER

A motorized valve controls flow through coil. The valve is located on the return line from the coil and has three ports — inlet, outlet and by-pass. Each chilled water coil is equipped with an air-bleed and a drain valve.

GENERAL SCHEMATIC WIRING INFORMATION

- 1 - The unit schematic wiring diagram format incorporates a horizontal power line which separates the line voltage circuit (motors-compressors-electric elements) from the controlling circuit. The motors, compressors and electric elements are located below the power line with the controlling circuit directly above the line.
- 2 - The graphic symbols for components and code lettering conforms to the "IEEE Standard and American National Standard" of graphic symbols for electrical diagrams. All symbols and code lettering used are approved by the International Electrotechnical Commission (IEC). Refer to Figure 22 for code and symbol identification.
- 3 - Terminal numbers on jack plugs are located by a ridge on the corner of the plug called the "Key." Refer to Figure 23 for proper numbering sequence.
- 4 - A component index chart is provided on each diagram which includes -
 - Code numbers (Key).
 - Description of component.
 - Location of component. See Example A in Figure 24.
 - Cross reference to other diagram sections. See Example B in Figure 24.
- 5 - Jack plugs are shown in the schematic circuit by both jack plug number and terminal number. In Example C of Figure 24, JP17-2 indicates jack plug number 17 and terminal number 2.
- 6 - Optional circuits are shown with arrow connections. Example D — Compressor 1 crankcase heater (HR4) and thermostat (S2) are used only with condenser heat and discriminator.
- 7 - Solid lines around a control indicate a complete control — Example E. Dashed lines around a control indicates only a part of a control — Example F.

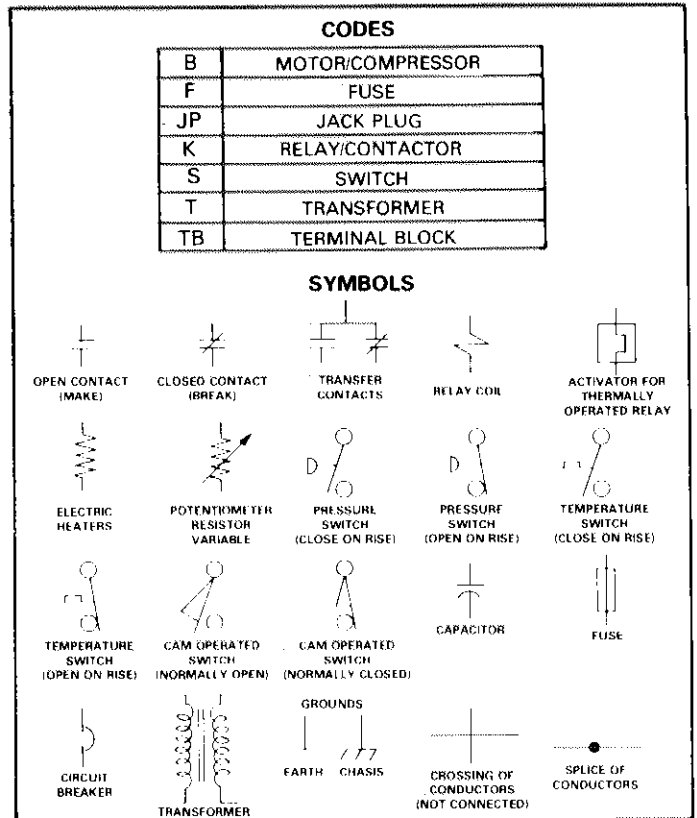

FIGURE 22

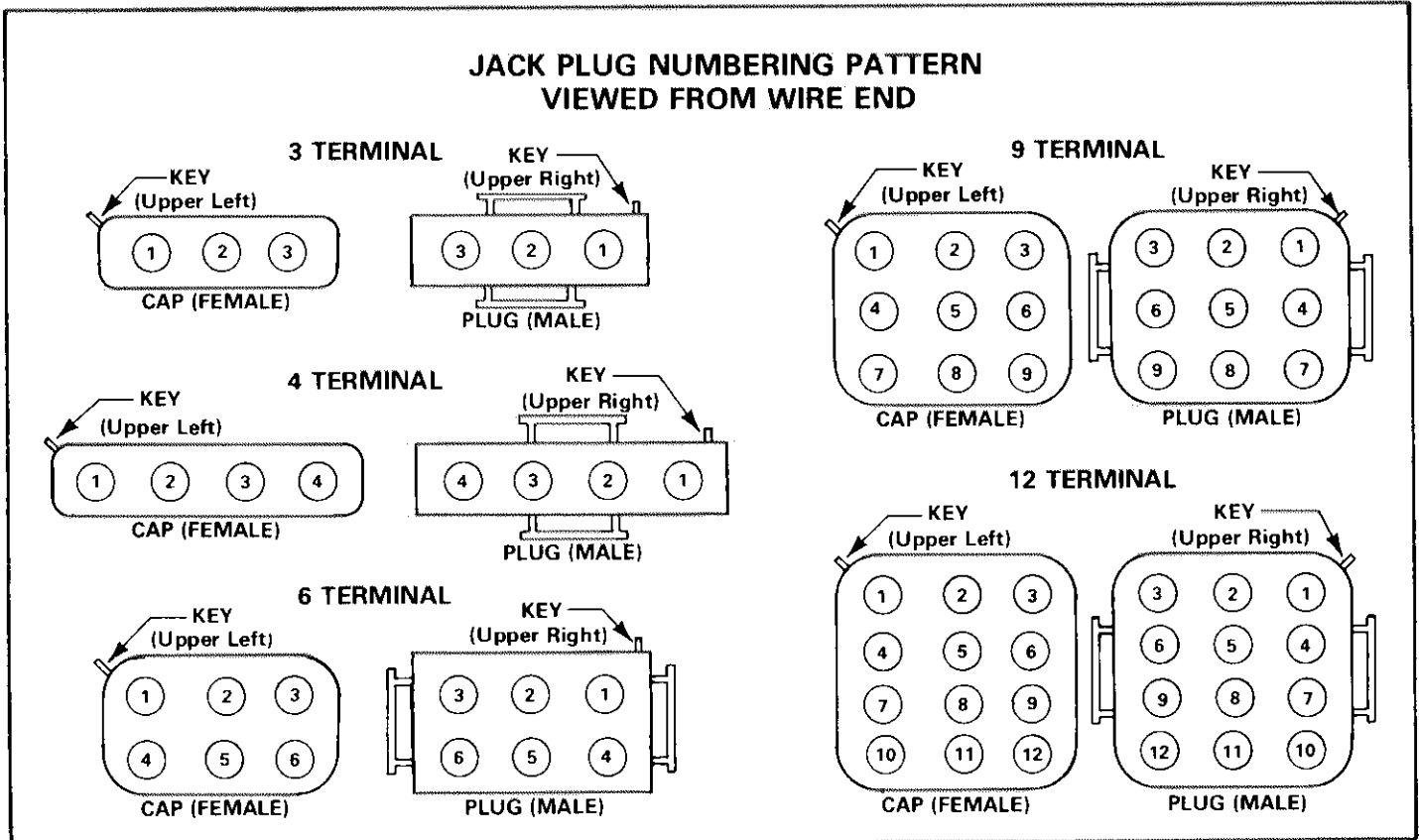

FIGURE 23

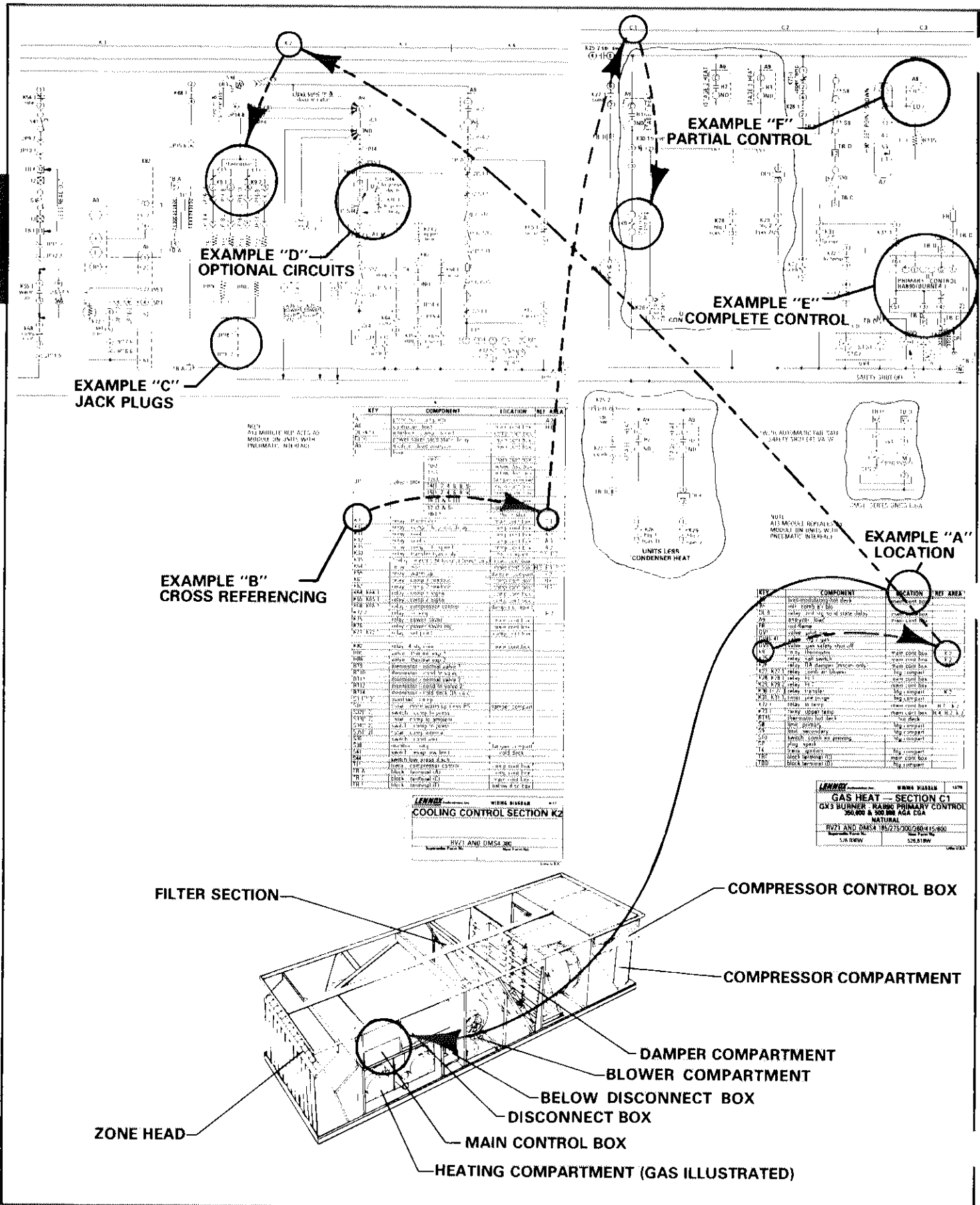

FIGURE 24
Page 19

COMPONENT

I - COMPONENT DESCRIPTION

Table 1 lists the electrical components by their key numbers and then gives a brief description of their function. Table 1 also lists control set points (where applicable).

II - FUSE REPLACEMENT

The fuse replacement tables on page 28 & 29 lists the fuses according to their key number, location within unit and fuse replacement size.

III - COMPONENT IDENTIFICATION

Figures 25 thru 28 illustrate the compressor control boxes, main control boxes, damper section and cold deck sensors. Refer to following sections on the pages given for additional illustrations.

- Heating Compartment.....Gas Heat (Figure 39 on page 42)
- Heating Compartment.....Electric Heat (Figures 46 & 47 on pages 49 & 50)
- Heating Compartment.....Hot Water Heat (Figure 52 on page 55)
- Heating Compartment.....Steam Heat (Figure 53 on page 55)
- Cooling Compartment...Chilled Water (Figure 80 on page 74)
- Compressor Compartment.....DX Cooling (Figures 66, 67, 68 on pages 61 & 62)
- Evaporator Section.....DX Cooling (Figure 74 on page 64)
- Indoor Air Blower.....Blowers (Figure 83 on page 76)
- Return Air Blower.....Blowers (Figure 84 on page 77)
- Zone Head.....Zone Control (Figure 116 on page 95)

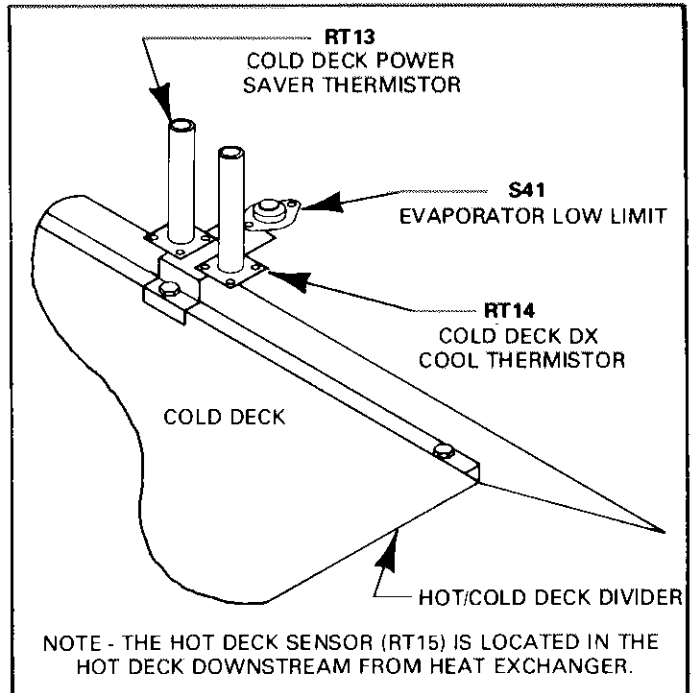
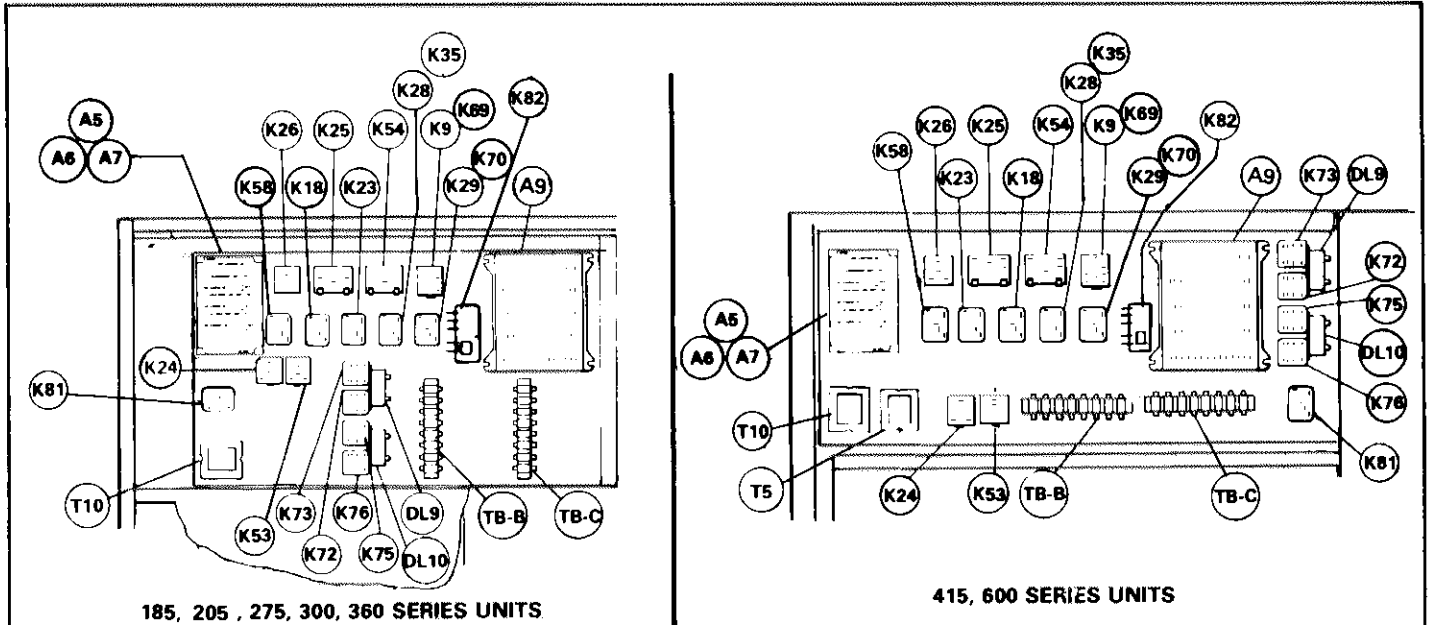

FIGURE 25



185, 205, 275, 300, 360 SERIES UNITS

415, 600 SERIES UNITS

| KEY | DESCRIPTION |
|------|------------------------------------|
| A5 | No. 1 limit controller |
| A6 | No. 2 limit controller |
| A7 | Hot Deck Limit |
| DL9 | 2nd stage burner solid-state delay |
| DL10 | Power saver solid-state delay |
| A9 | Load analyzer module |
| K9 | Thermistor relay |
| K18 | Indoor blower & R.A. blower relay |
| K23 | SMOKE RELAY (DMS4 ONLY) |
| K24 | Plus Relay |

| KEY | DESCRIPTION |
|-----|--------------------------------------|
| K25 | Sail switch relay |
| K26 | Discriminator relay |
| K28 | Heat 1 relay (gas) |
| K29 | Heat 2 relay (gas) |
| K35 | Electric heat lockout relay |
| K53 | Freezestat relay (hot water & steam) |
| K54 | Night relay |
| K58 | Filter remote lite relay |
| K69 | Chilled water relay |
| K70 | Sequence relay (electric heat) |

| KEY | DESCRIPTION |
|------|-------------------------|
| K72 | Lo temperature relay |
| K73 | Upper temperature relay |
| K75 | Power saver relay |
| K76 | Power saver delay relay |
| K81 | Interlock Relay |
| K82 | Four stage cool |
| T5 | Valve motor transformer |
| T10 | Control transformer |
| TB-B | Terminal block "B" |
| TB-C | Terminal block "C" |

FIGURE 26

GENERAL

SERIES COMPRESSOR CONTROL BOX

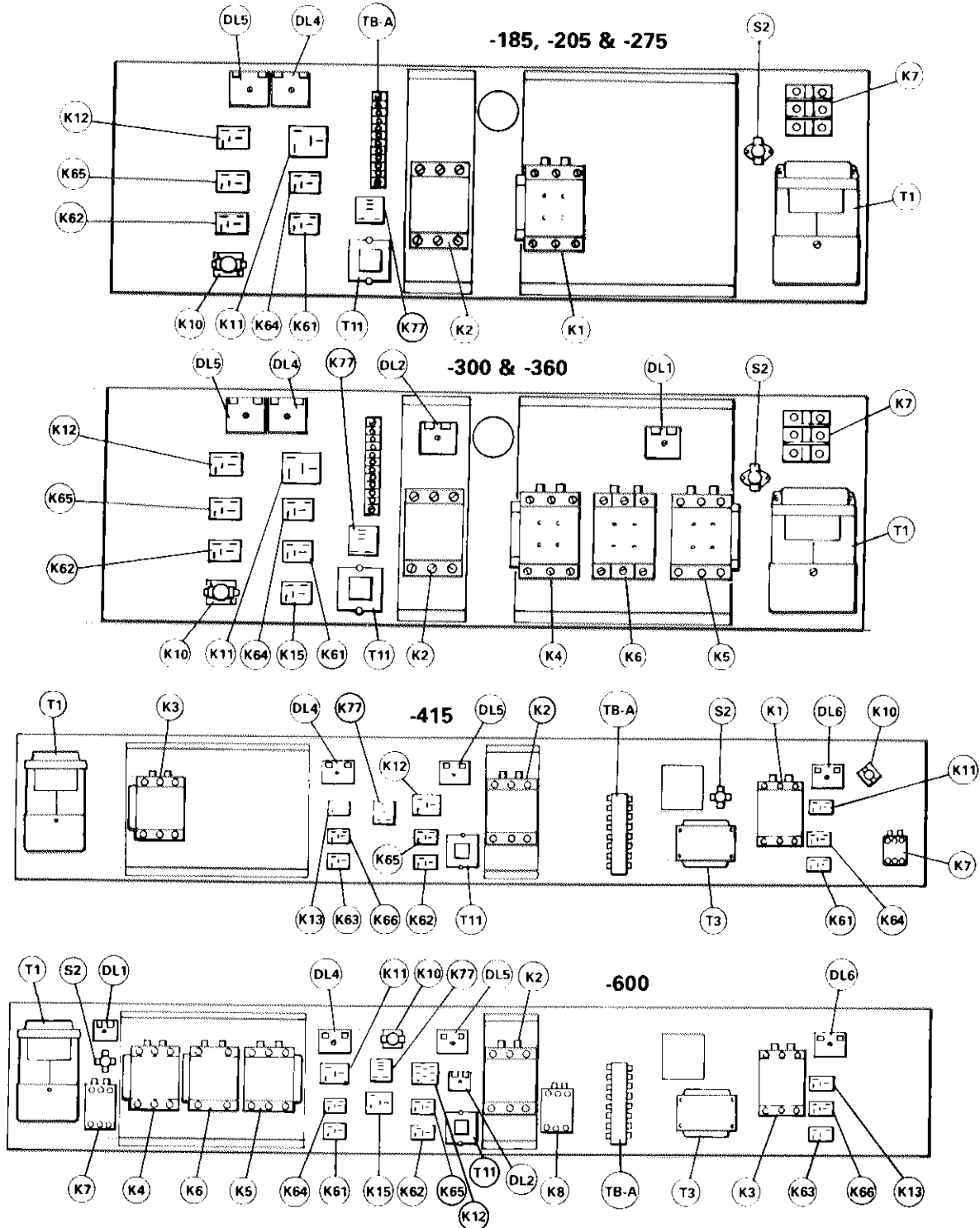

| KEY | DESCRIPTION |
|-----|----------------------------------------------------|
| DL1 | Compressor solid-state delay (L6 comp - lo speed) |
| DL2 | Compressor solid-state delay (L6 comp - hi speed) |
| DL4 | Compressor delay #1 |
| DL5 | Compressor delay #2 |
| DL6 | Compressor delay #3 |
| K1 | Compressor 1 & condenser fan 1 contactor (L2 only) |
| K2 | Compressor 2 & condenser fan 2 contactor |
| K3 | Compressor 3 & condenser fan 3 contactor |
| K4 | Compressor 1 "Hi" speed contactor (L6 only) |
| K5 | Compressor 1 "Lo" speed contactor (L6 only) |

| KEY | DESCRIPTION |
|-----|----------------------------------------------|
| K6 | Compressor 1 "Tie" speed contactor (L6 only) |
| K7 | Condenser fan 1 contactor (L6 only) |
| K8 | Condenser fan 2 contactor |
| K10 | Lo pressure switch delay |
| K11 | Cool 1 relay |
| K12 | Cool 2 relay |
| K13 | Cool 3 relay |
| K15 | Compressor 1 "Hi" speed relay (L6 only) |
| K61 | Readout relay 1 |
| K62 | Readout relay 2 |

| KEY | DESCRIPTION |
|-----|-----------------------------|
| K63 | Readout relay 3 |
| K64 | Signal relay 1 |
| K65 | Signal relay 2 |
| K66 | Signal relay |
| K77 | Set point relay |
| S2 | Crankcase heater thermostat |
| T1 | Power transformer |
| T3 | Smoke detector transformer |
| TBA | Terminal block "A" |

FIGURE 27

DAMPER SECTION

-185 THRU -360 SERIES

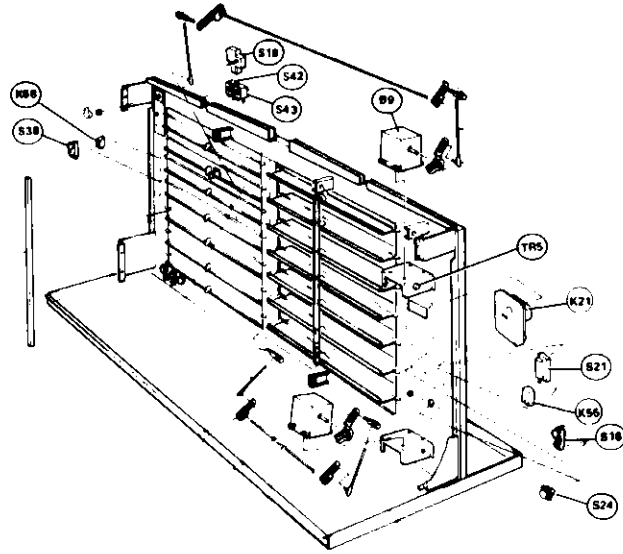

-415 AND -600 SERIES

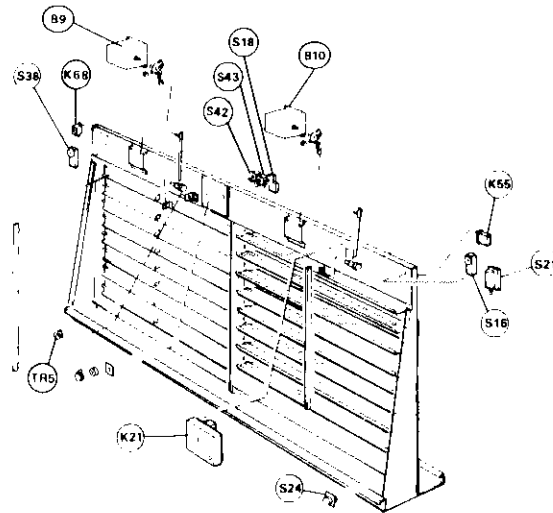

| KEY | DESCRIPTION |
|-----|---------------------------------------------|
| B8 | Power saver actuator (less smoke detection) |
| B9 | Outdoor air actuator (with smoke detection) |
| B10 | Return air actuator (with smoke detection) |
| K21 | Return air smoke detection relay |
| K55 | Warm-up DX cool relay |
| K68 | Compressor control relay |
| S16 | Morning warm-up thermostat |
| S18 | Enthalpy control |
| S21 | Filter pressure switch (roll filter) |
| S24 | Return air firestat |
| S38 | Compressor monitor |
| S42 | Low temperature limit |
| S43 | Upper temperature limit |
| TR5 | Remote minimum positioner |

FIGURE 28

TABLE 1

| COMPONENT | DESCRIPTION AND FUNCTION | LOCATION | SETTING |
|-----------|-----------------------------------------------------------------------------------------------------------------------------------------------------------------------------------------------------------------------------------------------------------------|------------------------|--------------|
| A(1-3) | Compressor Protection Modules — Prevents overheating in motor windings on all 15 ton compressors. | Internal to Compressor | ——— |
| A4 | Room Sensor — An air temperature sensor located within the zone that modulates hot & cold deck zone dampers to maintain zone temperature at room sensor set point. Also transmits an electronic signal to EA3 to control heating and cooling functions at unit. | Remote | Adj. |
| A5 | No. 1 Limit Controller — Modulates outdoor dampers so cold deck temperature does not drop below 50°F. | Main Control Box | ——— |
| A6 | No. 2 Limit Controller — Generates an overriding signal which cuts out compressors 2 or 3 when cold deck temperature drops below setpoint. | Main Control Box | 50°F or 55°F |
| A7 | Hot Deck Limit - Monitors hot deck temperature and raises the heating signal when the temperature exceeds set point. | Main Control Box | 90°F (Adj.) |
| A8 | Inverter (RVZ1 Only) - Changes the speed of indoor and return air blowers in response to the signal from EA5 integrating analyzer. | Blower Compartment | ——— |
| A9 | Load Analyzer Module — Monitors the signals from room & discharge sensors then initiates the heating and/or cooling modes as needed. | Main Control Box | ——— |
| A10 | Electric Heat Sequencer — Controls stepping of elements to satisfy heating demand. | Heating Compartment | ——— |
| A11 | Adder Module - Provides added terminals for applications using more than 12 zones. Used on both EA3 Load Analyzer Module and EA5 Integrating Analyzer Module. | Zone Head | ——— |
| A12 | Integrating Analyzer Module - Monitors the command signals from room sensors and then transmits an electronic blower command signal to inverter. Signal reflects the air requirements of unit. | Zone Head | ——— |
| A13 | Pneumatic Interface Module (DMS4 Only) - Converts the transducer electrical resistance changes into voltage signals which are then sent to the A13 module. | Below Disconnect Box | ——— |
| A14 | Mechanical Interface Module (DMS4 Only) - | Below disc box | ——— |
| B1 | Compressors — Initiates DX cool. | Compressor Compartment | ——— |
| B2 | Condenser Fans — Draws air across condenser coil to allow refrigerant to condense as it flows through coil. | | ——— |
| B3 | Indoor Blower Motor - - Provides supply air to hot and cold decks. | Blower Compartment | ——— |
| B4 | Return Air Blower Motor (option) -- Cycles with B3 blower motor. Overcomes resistance in return air system. | | ——— |
| B5 | Combustion Air Blower (gas) — Provides combustion air to burners. | Heating Compartment | ——— |
| B6 | Water Pump (hot water option) — Continuously circulates water through hot water coil. | Heating Compartment | ——— |
| B7 | Motorized Water Valve — Initiates hot water or chilled water operation. | Htg. or Cooling Compt. | ——— |
| B8 | Power Saver Actuator — On units less smoke detector, modulates outdoor dampers and return air dampers | Damper Compartment | ——— |
| B9 | Outdoor Air Actuator — On units with smoke detector, modulates outdoor dampers. | Damper Compartment | ——— |
| B10 | Return Air Actuator — On units with smoke detector, modulates return air dampers. | Damper Compartment | ——— |
| B11 | Motorized Steam Valve (steam) — Controls steam flow thru steam coil. | Heating Compartment | ——— |
| B12 | Zone Damper Actuator — Modulates zone damper to room sensor demand. | Zone Head | ——— |
| CMC1 | Nite Setback Clocktimer — 7 day clock cycles the unit into day, night and weekend operation. | Remote | Adj. |
| CMC2 | Roll Filter Clocktimer — Introduces a fixed amount of new filter media per 24 hours of unit operation. | Filter Compartment | Adj. |
| CR1 | Diode Night Blower (RVZ1 Only) - | Inverter | ——— |
| DL(1-2) | Compressor Solid-State Delay (L6 compressors) — Provide a 2 second time delay between "hi" and "lo" speeds. | Compressor Control Box | 2 sec. |
| DL4 | Compressor Delay #1 — Provides a 3 minute time delay for compressor 1. | Comp. Cont. Box | 3 min. |
| DL5 | Compressor Delay #2 — Provides a 10 minute time delay for compressor 2. | Comp. Cont. Box | 10 min. |
| DL6 | Compressor Delay #3 — Provides a 15 minute time delay for compressor 3. | Comp. Cont. Box | 15 min. |
| DL7- | Blower Solid-State Delay (DMS4 Only) - Allows OA & RA dampers to open before supply and return blowers operate. | Disconnect Box | 3 min. |
| DL8 | Burner Solid-State Delay — On gas units with R4795D primary control, delays burner operation for 5 seconds. | Heating Compartment | 5 sec. |

GENERAL

TABLE 1 (cont'd)

| COMPONENT | DESCRIPTION AND FUNCTION | LOCATION | SETTING |
|-----------|------------------------------------------------------------------------------------------------------------------------------------------------------------------------------------------------------------|------------------------|---------|
| DL9 | 2nd Stage Burner Solid-State Delay — Delays the start of second stage gas for 5 minutes. | Main Control Box | 5 min. |
| DL10 | Power Saver Solid-State Delay — Used with power saver relay (K75) & power saver delay relay (K76) to deactivate power saver for 3 minutes after comp. 1 is energized to allow cold deck time to stabilize. | Main Control Box | 3 min. |
| F | Fuses — Circuit protectors. | Throughout Unit | ——— |
| FR | Flame Rod (gas heat) — Monitors flame conditions to primary control. | Heating Compartment | ——— |
| GV1 | Pilot Gas Valve — Provides gas flow for pilot ignition. | Heating Compartment | ——— |
| GV3 | 1st Stage Gas Valve — Provides gas flow to either burner no. 1 or 1st stage of burner. | Heating Compartment | ——— |
| GV4 | 2nd Stage Gas Valve — Provides gas flow to either burner no. 2 or 2nd stage of burner. | Heating Compartment | ——— |
| GV5 | Safety Shutoff Gas Valve | Heating Compartment | ——— |
| HE(1-10) | Electric Elements — Provide resistance heat. | Heating Compartment | ——— |
| HR(1-3) | Compressor Crankcase Heaters — Warms the compressor to prevent liquid refrigerant from migrating to compressor during off cycle and "slugging" it on start-up. (continuously energized) | Cooling Compartment | ——— |
| HR4 | Compressor 1 Lo Ambient Crankcase Heater (option with condenser heat & discriminator) — Energized by S2 to provide additional heat for compressor 1 when operating at low temperature conditions. | Cooling Compartment | ——— |
| HR(5-6) | Electric Expansion Valves (condenser heat) — A condenser heat demand opens these valves and allows refrigerant to flow into accumulator and through condenser heat coil. | Compressor Compartment | ——— |
| K1 | Compressor 1 & Condenser Fan 1 Contactor (L2 only) — Energizes respective motors. | Comp. Cont. Box | ——— |
| K2 | Compressor 2 & Condenser Fan 2 Contactor — Energizes respective motors. | Comp. Cont. Box | ——— |
| K3 | Compressor 3 & Condenser Fan 3 Contactor — Energizes respective motors. | Comp. Cont. Box | ——— |
| K4 | Compressor 1 "Hi" Speed Contactor (L6 only) — Energizes the high speed circuit of compressor 1. | Comp. Cont. Box | ——— |
| K5 | Compressor 1 "Lo" Speed Contactor (L6 only) — Energizes the low speed circuit of compressor 1. | Comp. Cont. Box | ——— |
| K6 | Compressor 1 "Tie" Speed Contactor (L6 only) — Provides a positive interlock between Hi & Lo speeds to prevent both speeds from being energized simultaneously. | Comp. Cont. Box | ——— |
| K7 | Condenser Fan 1 Contactor — Energizes condenser fan 1 motor. | Comp. Cont. Box | ——— |
| K8 | Condenser Fan 2 Contactor (RVZ1-600 only) — Energizes condenser fan 2 motor. | Comp. Cont. Box | ——— |
| K9 | Thermistor Relay — Initiates condenser heat operation. | Main Control Box | ——— |
| K10 | Lo Pressure Switch Delay — Shunts out low pressure switch (S34) during low ambient start-up. | Comp. Cont. Box | 1 min. |
| K11 | Cool 1 Relay — Initiates compressor 1 operation. | Comp. Cont. Box | ——— |
| K12 | Cool 2 Relay — Initiates compressor 2 operation. | Comp. Cont. Box | ——— |
| K13 | Cool 3 Relay — Initiates compressor 3 operation. | Comp. Cont. Box | ——— |
| K15 | Comp. 1 "Hi" Speed Rly. (L6 only) — The EA3 "C3" or "C4" contacts energize K15 which in turn energizes K4 to run comp. 1 at high speed. | Comp. Cont. Box | ——— |
| K16 | Blower Relay (RVZ1 Only) - Energizes blower motor | Disconnect Box | ——— |
| K16 | Indoor Blower Contactor (DMS4 Only) - Energizes indoor blower motor | Disconnect Box | ——— |
| K17 | Blower Contactor — Energizes blower motor. (Smoke detection only). | Disconnect Box | ——— |
| K18 | Indoor Blower & Return Air Blower Relay — Energizes K16 & K17 Coils to start respective motors. | Main Control Box | ——— |
| K19 | Shutdown Relay (with smoke detection) — Controls blower and damper operation per smoke detection option described on page 13. | Disconnect Box | ——— |
| K21 | Return Air Smoke Detector (with smoke detection) — De-energizes shutdown relay (K19) in response to the smoke detection option used, upon the presence of smoke in the return air. | Damper Compartment | ——— |
| K22 | Filter Section Smoke Detector (with smoke detection) — Shuts down K19, in response to the smoke detection option used, upon the presence of smoke in the supply air stream. | Blower Compartment | ——— |
| K23 | Smoke Relay - smoke detection options 2, 3 & 4 (DMS4 Only) — Nite set-back operation energizes K23 which then energizes K19 to end smoke detection operation. | Main Control Box | ——— |

TABLE 1 (cont'd)

| COMPONENT | DESCRIPTION AND FUNCTION | LOCATION | SETTING |
|-------------------|--------------------------------------------------------------------------------------------------------------------------------------------------------------------------------------------------------------------------|------------------------|--------------|
| K24 | Plus Relay (smoke detector options 3 & 4) — When smoke detectors (K21 & K22) are activated, K23 provides power to Outdoor Air Damper Actuator Transformer (T8). It also opens outside dampers and closes return dampers. | Main Control Box | ——— |
| K25 | Sail Switch Relay — Shuts down unit when the indoor blower motor is off. | Main Control Box | ——— |
| K26 | Damper Relay (option, with condenser heat only) — Holds the outdoor dampers at minimum position at a given switch point in the heating mode. | Main Control Box | ——— |
| K27 | Combustion Air Blower Relay — Energizes combustion air blower motor (B5). | Heating Compartment | ——— |
| K28 | Heat 1 Relay (gas) — Initiates either burner no. 1 (2 burner units) or 1st stage burner (single burner units). | Heating Compartment | ——— |
| K29 | Heat 2 Relay (gas) — Initiates either burner no. 2 (2 burner units) or 2nd stage burner (single burner units.) | Heating Compartment | ——— |
| K30 | Transfer Relay (gas) — Compressor 1 operation energizes K30, which then shifts the unit into condenser heat and 1st stage gas heat. With compressor 1 off, unit returns to 1st and 2nd stage gas heating. | Heating Compartment | ——— |
| K31 | Prepurge Relay (gas) — Provides combustion chamber prepurge before 1st stage of gas comes on. | Heating Compartment | ——— |
| K32 | Burner Alarm Relay (gas, 50 Hz only) — The primary control energizes K32 to set off an alarm when the burners are locked out. | Heating Compartment | ——— |
| K33 | Element 1 Stage 1 Contactor (elec.) — Operates first half of element 1. | Heating Compartment | ——— |
| K34 | Element 1 Stage 2 Contactor (elec.) — Operates second half of element 1. | Heating Compartment | ——— |
| K35 | Electric Heat Lockout Relay (DX cool only) — Compressor 1 operation energizes K35 to lock out all elements except no. 1. | Main Control Box | ——— |
| K36-K38 | Discriminator H1, H2, H5 Relays (elec.) — These relays bring on discriminator function (damper relay - K26) as "H2" or "H5" contacts close and terminate discriminator function as "H1" or "H5" contacts open. | Heating Compartment | ——— |
| K39-K47 | Elements 2-10 Contactors (elec.) — Operates respective elements. | Heating Compartment | ——— |
| K48 | Element 7 Delay Relay (7 element elec. only) — Delays the last element for 40 seconds. | Heating Compartment | 40 sec. |
| K49 | Element 10 Delay Relay (10 element elec. only) — Provides a 40 second time delay for element no. 10. | Heating Compartment | 40 sec. |
| K50 | Element 7-8-9 Delay Relay (10 element elec. only) — After "H5" close, K50 provides a 25 second delay for elements 7 & 8 and a 40 second delay for element 9. | Heating Compartment | 25 & 40 sec. |
| K51 | Discriminator Latch Relay (elec.) — Latches in when "H2" switch on EA5 closes. Keeps K26 damper relay energized until "H1" on EA3 opens. | Heating Compartment | ——— |
| K53 | Freezestat Relay (hot water & steam) — K53 must be energized before valve (B6) can modulate. K53 is either energized by upper temperature relay (K73) or freezestat (S40). | Main Control Box | ——— |
| K54 | Night Relay — Cuts out power saver and DX cooling during nite setback. | Main Control Box | ——— |
| K55 | Warm-up DX Cool Relay — K55 holds outdoor dampers at closed position when it's energized by morning warm-up thermostat (S16). | Damper Compartment | ——— |
| K57 | A Relay (roll filter with timer control) — Operates filter motor when filter media runout switch (S20) and clock timer motor (CMC2) are closed. | Filter Compartment | ——— |
| K58 | Filter Remote Lite Relay (roll filter & readout panel) — Lights a bulb at readout panel to indicate the end of media. Is energized by filter media switch (S20). | Remote | ——— |
| K59 | Phone Delay Relay (readout panel) — Lights a bulb at readout panel to indicate a locked out primary control. Also can use additional contacts for phone. | Remote | ——— |
| K60 | Delay Relay (readout panel) — Provides a 60 second delay before lighting a bulb at readout panel to indicate an open set of contacts within the compressor safety circuit. | Remote | 1 min. |
| K61-63 K64-K66 | K61-K63 Readout Relays & K64-K66 Signal Relays — These relays work in conjunction to indicate an open compressor safety circuit. An open circuit will energize damper relay (K60). | Compressor Control Box | ——— |
| K68 | Compressor Control Relay — K68 isolates compressor control circuit to transformer (T11). | Damper Compt. | ——— |
| K69 | Chilled Water Relay — During nite setback, K69 terminates cooling. | Main Control Box | ——— |
| K70 | Sequence Relay (electric heat) — K70 provides electric heat when energized by indoor blower sail switch (S31). | Main Control Box | ——— |
| K71 | Burner Relay (R4795D primary control only) — Burner delay (DL8) controls K71, which in turn controls burner operation. | Heating Compartment | ——— |
| K72 | Lo Temperature Relay — Lower temp. limit (S42) energizes K72. On units with condenser heat, K72 locks out comp. 1 below set point and locks out heat 2 above set point. | Main Control Box | ——— |

TABLE 1 (cont'd)

| COMPONENT | DESCRIPTION AND FUNCTION | LOCATION | SETTING |
|----------------|---------------------------------------------------------------------------------------------------------------------------------------------------------------------------------------------------------|------------------------|-----------------------------------|
| K73 | Upper Temperature Relay - S43 energizes K73. K73 locks out hi speed on L6 compressors. In addition K73 locks out all gas, electric, hot water and steam heat. | Main Control Box | _____ |
| K75 & K76 | Power Saver Relay & Power Saver Delay Relay — Used with power saver delay (DL10) to deactivate power saver for 3 minutes after compressor 1 is energized. | Main Control Box | 3 min. |
| K77 | Set Point Relay — After compressor 2 starts, K77 shifts the cold deck setting from 55°F to 50°F for no. 2 limit controller (A6). | Compressor Control Box | _____ |
| K80 | Night Blower Relay (RVZ1 Only) - K80 energizes night blower control (R1) during night setback conditions, K80 also energizes R1 whenever the smoke detector alarm is activated. (Smoke detection only.) | Disconnect Box | _____ |
| K81 | Interlock Relay | Main Control Box | _____ |
| K82 | Four Stage Cool Relay — Controls high speed of two speed compressor | Main Control Box | _____ |
| L1 | Comp. 1 Hot Gas By-pass Solenoid (L6 only) — On two speed compressors, L1 only permits hot gas by-pass operation during low speed. | Comp. Compartment | _____ |
| PC1-1 PC2-1 | Alarm Contacts Burner 1 & Burner 2 (used with readout panel) — The primary control energizes these relays to light a bulb at readout panel when the burners are locked out. | Heating Compartment | _____ |
| R1 | Night Blower Control (RVZ1 Only) - Switches the blower motor into a night time speed during night setback. This allows smoke detection during night setback. (Smoke detector only.) | Below Disconnect Box | adj. |
| R2 | Impedance Drop Resistor (RVZ1 Only) | Inverter | _____ |
| R3 | Minimum Positioner | Damper Compartment | Adj. |
| R11-R18 | Zone Damper Potentiometers (DMS4 Only) - Mechanical Interface | Zone Head | Adj. |
| RT4 | Discharge Sensor — Used with room sensor. Senses discharge air temperature to reposition zone damper in anticipation of the effect on room temperature. | Zone Head | _____ |
| RT7 & RT8 | Hi & Lo Pressure Transducer — pneumatic (DMS4 Only) — Converts air pressure changes into electrical resistance changes. | Below Disconnect Box | See Instruc. |
| RT9 & RT11 | Normal Thermistors (condenser heat) — Without a condenser heat demand these thermistors are energized to maintain the normal refrigerant circuit. | _____ | _____ |
| RT10 & RT12 | Condenser Heat Thermistors — K9 activates these thermistors which then open HR5 & HR6 to begin condenser heat operation. | _____ | _____ |
| RT13 | Cold Deck Power Saver Thermistor — Senses cold deck temperature for no. 1 limit controller (A5). | _____ | _____ |
| RT14 | Cold Deck DX Cool Thermistor — Senses cold deck temperature for no. 2 limit controller (A6). | _____ | _____ |
| RT15 | Hot Deck Thermistor (RVZ1 Only) — Senses hot deck temperature for hot deck limit (A7). | _____ | _____ |
| RT16 & 17 | Thermistor — remote | _____ | _____ |
| S1 | Compressor 1 Condenser Heat High Pressure Switch — Starts condenser fan 1 when the head pressure exceeds setting to maintain normal operating pressure during condenser heat cycles. | Compressor Compartment | on 285 psi off 145 psi |
| S2 | Crankcase Heater Thermostat (option with condenser heat & discriminator) — Energizes HR4 to provide additional heat to compressor 1 at temperature below setting. | Compressor Control Box | Fixed 35°F close, 60°F open |
| S3 | Compressor Overload — Protects compressor circuits from overheating. | Comp. Compart. | _____ |
| S4 | Blower Motor Overloads — Protects blower motor circuit from overheating. | Disconnect Box | _____ |
| S5 | Return Air Motor Overloads (7-1/2 hp only) — Protects motor circuit from overheating. | Disconnect Box | _____ |

GENERAL

TABLE 1 (cont'd)

| COMPONENT | DESCRIPTION AND FUNCTION | LOCATION | SETTING |
|-----------|--------------------------------------------------------------------------------------------------------------------------------------------------------------------------------------------------|------------------------|------------------------------|
| S6 | Fan Control (gas only) — During nite setback, S6 allows indoor blower to run to dissipate heat from heat exchanger after a burner on cycle. | Heating Compartment | 120°F on, 90° off |
| S7 | Remote Test Station (smoke detection) — Simulates smoke conditions to check performance of smoke detectors. | Heating Compartment | ———— |
| S8 | Primary Limit Control — Shuts off burner(s) when hot deck temperatures exceed switch setting. | Heating Compartment | 150°F or 170°F |
| S9 | Secondary Limit Control — Shuts off burner when hot deck temperatures exceed switch setting. | Heating Compartment | 150°F |
| S10 | Combustion Air Proving Switch — Makes sure combustion blower (B5) is running before burners can operate. | Heating Compartment | .5 wc |
| S11 | Hi Pressure Gas Switch (R4795D primary control) — Opens circuit to burner when gas pressure exceeds setting. (F.I.A. & F.M.) | Heating Compartment | see instructions |
| S12 | Lo Pressure Gas Switch (R4795D primary control) — Opens circuit to burner when gas pressure drops below set point. (F.I.A. & F.M.) | Heating Compartment | see instructions |
| S13 | Door Interlock Switch (electric) — Assures that element access panel is in place before electric heat can come on. | Heating Compartment | ———— |
| S14 | Safety Limit (electric) — Cuts out respective element at temperatures above setting. | Elements | 300°F |
| S15 | Hi Limit (electric) — Shuts off electric heat when hot deck temperatures exceed switch setting. | Heating Compartment | 180°F |
| S16 | Morning Warm-Up Thermostat — Opens at return air temperatures below setting to de-energize DX cool warm-up relay (K55) to hold outdoor dampers at closed position during morning warm-up period. | Damper Compartment | 70°F |
| S17 | Sandstorm Switch (optional) — This is a manual switch which closes the outdoor dampers. | Remote | manual |
| S18 | Enthalpy Control — Senses heat content of outside air and closes outdoor dampers to minimum position when heat content arises above set point. | Damper Compartment | “A” adj. |
| S20 | Media Runout Switch (roll filter) — Energizes filter remote light relay (K58) when media runs out. | Filter Compartment | ———— |
| S21 | Filter Pressure Switch (pressure, roll filter) — Introduces media into airstream whenever pressure differential across filter curtain is reached indicating dirty filter. | Filter Compartment | see instructions |
| S22 | Jog Switch (roll filter) — A manual switch which advances filter media. | Filter Compartment | manual |
| S23 | Metering Switch (timer, roll filter) — Cam energizes S23 after 1 inch of media has passed. S23 stops drive motor until next time interval. | Filter Compartment | ———— |
| S24 | Return Air Firestat — Terminates entire unit operation when return air temperature exceeds set point. | Damper Compt. | 136°F |
| S25 | Supply Air Firestat — Terminates entire unit operation when supply air temperature exceeds set point. | Blower Compt. | 136°F |
| S27 | Nite Thermostat — During nite setback S27 energizes unit heating when temperature drops below set point. | Remote | adj. |
| S28 | Manual Timer (readout panel) — Overrides nite setback controls to provide regular heating functions during night building occupancy. | Remote | 0-8 hours (manual) |
| S29 | System Switch (readout panel) — Shuts down entire unit at readout panel. | Remote | manual |
| S30 | Filter Switch — Lights a bulb at readout panel to indicate a dirty filter. | Blower Compt. | ———— |
| S31 | Blower Proving Switch — Energizes sail switch relay (K25) when air flow is detected at indoor blower. | Blower Compt. | ———— |
| S32 | Compressor Hi Pressure Switch — Shuts off compressor when refrigerant pressure exceeds set point. | Internal to Compressor | 410 psi |
| S33 | Compressor Lo Ambient Thermostat — Shuts off compressor when temperature at thermostat drops below set point. | Internal to Compressor | 25°F |
| S34 | Compressor Lo Pressure Switch — Shuts off compressor when refrigerant pressure drops below set point. | Internal to Compressor | 20 psi off, 50 psi on |
| S35 | Internal Compressor Thermostat (L2 compressors except 15 tons) — Shuts off compressor when internal temperature rises above set point. | Internal to Compressor | ———— |
| S36 | Condensing Unit Switch (readout panel) — A manual switch which stops all cooling. | Remote | manual |
| S38 | Compressor Monitor — Locks out compressors whenever the outdoor air temperature falls below set point. | Damper Compartment | 40°F to 90°F or 55°F to 85°F |
| S39 | System Switch (optional) — A manual switch which shuts down entire unit. | Remote | ———— |
| S40 | Freezestat (hot water & steam) — S40 energizes freezestat relay (K53) at temperatures below set point to prevent coil freezing. | Heating Compartment | 34°F close, 60°F open |

TABLE 1 (cont'd)

| COMPONENT | DESCRIPTION AND FUNCTION | LOCATION | SETTING |
|-----------|----------------------------------------------------------------------------------------------------------------------------|------------------------|------------------------|
| S41 | Evaporator Low Limit — Locks out compressors when cold deck temperature drops below set point. | Cold Deck | 42°F opens, 57°F close |
| S42 | Low Temperature Limit — Energizes LO temperature relay (K72) when temperatures drop below set point. | Damper compartment | 10°F to 40°F adj. |
| S43 | Upper Temperature Limit — S43 opens contacts at temperatures above set point to de-energize upper temperature relay (K73). | Damper Compartment | 75°F close |
| S44 | Discharge Low Pressure Switch - Locks out compressor whenever discharge pressure drops below set point. | Compressor Compartment | 20 psi off, 50 psi on |
| S45 | Interlock Switch - Prevents unit from operating while blower access panels are removed. | Blower Compartment | _____ |
| S46 | Interlock Switch - Prevents unit from operating while blower access panels are removed. | Blower Compartment | _____ |
| SP | Spark Plug (gas) — Ignites pilot. | Heating Compartment | .035 gap |
| T1 | Transformer (380-575V) — Drops line voltage to 220V for compressor crank-case heaters and compressor control circuit. | Comp. Control Box | _____ |
| T2 | Control Power Transformer — Drops line voltage to 120V for 60 Hz units and 215V for 50 Hz for control circuit voltages. | Main Control Box | _____ |
| T3 | Smoke Detector Transformer (50 Hz only) — Drops 215V to 120V for smoke detection options. | Compressor Control Box | _____ |
| T4 | Ignition Transformer (gas) — Increases voltage to spark plug for ignition | Heating Compartment | _____ |
| T5 | Valve Motor Transformer (hot water, steam & chilled water) — Provides 24V power to water valve (B7). | Main Control Box | _____ |
| T6 | Damper Actuator Transformer — Provides 24V power to zone actuators (B6). | Zone Head | _____ |
| T7 | Power Saver Actuator Transformer (less smoke detectors) — Provides 24V power to power saver actuator (B8). | Blower Compartment | _____ |
| T8 | Outdoor Air Damper Actuator, Transformer (with smoke detection) — Provides 24V power to outdoor actuator (B8). | Blower Compartment | _____ |
| T9 | Return Air Damper Actuator Transformer (with smoke detection) — Provides 24V power to return air actuator (B9). | _____ | _____ |
| T10 | Control Transformer — Provides 24V power to the control circuit. | Main Cont. Box | _____ |
| T11 | Compressor Control Transformer — Provides 24V power to the isolated compressor control circuit. | _____ | _____ |
| T12 | Transformer Integrating Analyzer | Below Disc Box | _____ |
| T13 | Inverter Transformer (RVZ1 Only) - Provides 460V to inverter. | _____ | _____ |
| TB-A | Terminal Block "A" | Comp. Cont. Box | _____ |
| TB-B | Terminal Block "B" | Main Cont. Box | _____ |
| TB-C | Terminal Block "C" | Main Cont. Box | _____ |
| TB-D | Terminal Block "D" | Heating Compartment | _____ |
| TB-E | Terminal Block "E" | Heating Compartment | _____ |
| TB-F | Terminal Block "F" — readout | Below Disc. Box | _____ |
| TB-G | Terminal Block "G" (RVZ1 Only) | Disconnect Box | _____ |
| TB-N | Terminal Block "N" — minus reference strip | Zone Head | _____ |
| TB-Z | Terminal Block "Z" — room sensor | Below Disconnect Box | _____ |

GENERAL

DMS4 ALLOWABLE REPLACEMENT FUSE TABLE (AMPS)

| Wiring Diagram Key | Voltage | | 208V & 230V Units (Use 250V Fuses) | | | | | 460V & 575V* Units (Use 600V Fuses) | | | | | | |
|--------------------|-----------------------------|--------------|------------------------------------|---------|---------|---------|---------|-------------------------------------|------------|--------|--------|--------|--------|--------|
| | DMS4 Model | | 185 205 | 275 | 300 | 360 | 415 | 600 | 185 205 | 275 | 300 | 360 | 415 | 600 |
| F1 | Compressor 1 | | 50A | 60A | 100A | 100A | 60A | 100A | 25A | 30A | 50A | 50A | 30A | 50A |
| F2 | Compressor 2 | | 50A | 60A | 60A | 100A | 60A | 100A | 25A | 30A | 30A | 50A | 30A | 50A |
| F3 | Compressor 3 | | ---- | ---- | ---- | ---- | 60A | 100A | ---- | ---- | ---- | ---- | 30A | 50A |
| F4 | Compressor Control | | 3-2/10A | 3-2/10A | 3-2/10A | 3-2/10A | 3-2/10A | 3-2/10A | 1-1/8A | 1-1/8A | 1-1/8A | 1-1/8A | 1-1/8A | 1-1/8A |
| F5 | 2 KVA Transformer | | 20A | 20A | 20A | 20A | 20A | 20A | 10A | 10A | 10A | 10A | 10A | 10A |
| F6 | Indoor Blo. Mtr. | 3 & 5 hp | 20A | 20A | 20A | 20A | 20A | 20A | 10A | 10A | 10A | 10A | 10A | 10A |
| | | 7½ & 10 hp | 40A | 40A | 40A | 40A | 40A | 40A | 20A | 20A | 20A | 20A | 20A | 20A |
| F7 | R.A. Blo. Mtr. | 15 hp | ---- | ---- | ---- | ---- | 60A | 60A | ---- | ---- | ---- | ---- | 30A | 30A |
| | | 1½ thru 5 hp | 20A | 20A | 20A | 20A | 20A | 20A | 10A | 10A | 10A | 10A | 10A | 10A |
| F8-F17 | Electric Heat | | 60A | 60A | 60A | 60A | 60A | 60A | 30A | 30A | 30A | 30A | 30A | 30A |
| F19 | 2 KVA Transformer Secondary | | 15A | 15A | 15A | 15A | 15A | 15A | 15A | 15A | 15A | 15A | 15A | 15A |

USE CLASS K, CLASS RK, OR CLASS R TIME-DELAY FUSES.
 *CAUTION: FOR CANADA USE ONLY TIME-DELAY TYPE FUSES MARKED "D" OR HRC FORM 1 FUSES.

RVZ1 ALLOWABLE REPLACEMENT FUSE TABLE (AMPS)

| Wiring Diagram Key | Voltage | | 208V & 230V Units (Use 250V Fuses) | | | | | 460V & 575V* Units (Use 600V Fuses) | | | | | | |
|--------------------|-----------------------------|--|------------------------------------|---------|---------|---------|---------|-------------------------------------|------------|--------|--------|--------|--------|--------|
| | RVZ1 Model | | 185 205 | 275 | 300 | 360 | 415 | 600 | 185 205 | 275 | 300 | 360 | 415 | 600 |
| F1 | Compressor 1 | | 50A | 60A | 100A | 100A | 60A | 100A | 25A | 30A | 50A | 50A | 30A | 50A |
| F2 | Compressor 2 | | 50A | 60A | 60A | 100A | 60A | 100A | 25A | 30A | 30A | 50A | 30A | 50A |
| F3 | Compressor 3 | | ---- | ---- | ---- | ---- | 60A | 100A | ---- | ---- | ---- | ---- | 30A | 50A |
| F4 | Compressor Control | | 3-2/10A | 3-2/10A | 3-2/10A | 3-2/10A | 3-2/10A | 3-2/10A | 1-1/8A | 1-1/8A | 1-1/8A | 1-1/8A | 1-1/8A | 1-1/8A |
| F5 | 2 KVA Transformer | | 20A | 20A | 20A | 20A | 20A | 20A | 10A | 10A | 10A | 10A | 10A | 10A |
| F8-F17 | Electric Heat | | 60A | 60A | 60A | 60A | 60A | 60A | 30A | 30A | 30A | 30A | 30A | 30A |
| F19 | 2 KVA Transformer Secondary | | 15A | 15A | 15A | 15A | 15A | 15A | 15A | 15A | 15A | 15A | 15A | 15A |

USE CLASS K, CLASS RK, OR CLASS R TIME-DELAY FUSES.
 *CAUTION: FOR CANADA USE ONLY TIME-DELAY TYPE FUSES MARKED "D" OR HRC FORM 1 FUSES.

RVZ1 FUSE REPLACEMENT TABLE FOR INVERTER (F18)

| BLOWER MOTOR H.P. | | VOLTAGE | | | |
|-------------------|--------|---------|-------|-------|-------|
| INDOOR | RETURN | 208V | 240V | 460V | 575V* |
| 3 | ---- | LPN15 | LPN15 | LPS15 | LPS15 |
| 3 | 1.5 | LPN20 | LPN20 | LPS15 | LPS15 |
| 5 | ---- | LPN25 | LPN25 | LPS15 | LPS15 |
| 5 | 1.5 | LPN35 | LPN30 | LPS15 | LPS15 |
| 5 | 3 | LPN40 | LPN35 | LPS15 | LPS15 |
| 7.5 | ---- | LPN40 | LPN35 | LPS20 | LPS15 |
| 7.5 | 1.5 | LPN45 | LPN40 | LPS20 | LPS15 |
| 7.5 | 3 | LPN50 | LPN45 | LPS25 | LPS20 |
| 7.5 | 5 | LPN60 | LPN50 | LPS25 | LPS20 |
| 10 | ---- | LPN50 | LPN45 | LPS25 | LPS15 |
| 10 | 1.5 | LPN60 | LPN50 | LPS25 | LPS20 |
| 10 | 3 | LPN60 | LPN50 | LPS30 | LPS20 |
| 10 | 5 | LPN70 | LPN60 | LPS30 | LPS25 |
| 10 | 7.5 | LPN70 | LPN70 | LPS35 | LPS25 |
| 15 | ---- | LPN80 | LPN70 | LPS35 | LPS30 |
| 15 | 1.5 | LPN80 | LPN70 | LPS40 | LPS30 |
| 15 | 3 | LPN90 | LPN80 | LPS40 | LPS30 |
| 15 | 5 | LPN90 | LPN80 | LPS45 | LPS35 |
| 15 | 7.5 | LPN100 | LPN90 | LPS45 | LPS35 |

*CAUTION: For Canada use only time delay type fuses marked "D" or HRC Form 1 fuses.

GENERAL

START-UP AND PERFORMANCE CHECK LIST

Job Name _____ Job Number _____ Date _____
 Job Location _____ City _____ State _____
 Installer _____ City _____ State _____
 Unit Model No. _____ Serial No. _____ Serviceman _____

TEMPERATURE AT TIME OF INSPECTION

Outdoor air D.B. _____ Return Air _____
 Mixed Air _____ Hot Deck _____ Cold Deck _____

ELECTRICAL

Unit Nameplate Voltage _____
 Minimum Circuit Ampacity Disconnect 1 _____ 2 _____ 3 _____
 Maximum Fuse Size Disconnect 1 _____ 2 _____ 3 _____
 Wiring connections checked for tightness
 Supply Voltage - Unit Off 1 & 2 _____ 1 & 3 _____ 2 & 3 _____
 Electronic circuit checked for shorts
 *Transformer Secondary Voltage T10 _____

SUPPLY BLOWER/FILTER

Motor HP _____ Make _____
 Shipping Blocks Removed Filters in place
 Lub & Bearings: Motor Blowers Pulleys Tight
 Belt Tension & Alignment Proper Blower Rotation
 Motor Amps 1 _____ 2 _____ 3 _____
 Smoke Detector Operates
 *Transformer Secondary Voltage T2 _____ T3 _____
 Blower RPM _____ CFM _____
 Roll Filters Only: Pressure Control Set Clocktimer Adjusted

RETURN BLOWER

Motor Hp _____ Make _____
 Shipping Blocks Removed
 Lub & Bearings: Motor Fan Pulleys Tight
 Belt Tension & Alignment Proper Fan Rotation
 Motor Amps 1 _____ 2 _____ 3 _____

OUTSIDE-RETURN-EXHAUST DAMPERS

Enthalpy Control Setting _____
 Morning Warmup Thermostat Setting _____
 Damper Linkage Adjusted & Tight
 Minimum Air Adjusted (Blade opening) _____ Outside Air _____ %
 *Transformer Secondary Voltage T7 _____ T8 _____ T9 _____
 Shipping screws removed from exhaust dampers
 Exhaust dampers open & close freely

ZONE DAMPERS

*Transformer Secondary Voltage T6 _____
 Balancing dampers adjusted
 Damper blades free & not binding
 Zones ducted & wired to correct room sensor

CHILLED WATER

Water Connections Tight Water Pump Operating
 Water valve adjusted Air Bl'd from system
 *Transformer Secondary Voltage T5 _____

SYSTEM TIME CLOCK

Normal _____ Setback _____ Skip day(s) _____

DX COOLING

Crankcase heater energized 24 hours before installing compressor fuses
 Refrigerant Lines Secure Service Valves Backseated
 Proper Condenser Fan Rotation Fan 1 2 3 4
 Hot Gas Bypass Valve Operating
 *Transformer Secondary Voltage T1 _____
 Voltage with compressors operating 1&2 _____ 1&3 _____ 2&3 _____
 Amps:
 Supply 1 _____ 2 _____ 3 _____
 Condenser Fan Motor No. 1 1 _____ 2 _____ 3 _____
 Condenser Fan Motor No. 2 1 _____ 2 _____ 3 _____
 Condenser Fan Motor No. 3 1 _____ 2 _____ 3 _____
 Condenser Fan Motor No. 4 1 _____ 2 _____ 3 _____
 Compressor No. 1 1 _____ 2 _____ 3 _____
 Compressor No. 2 1 _____ 2 _____ 3 _____
 Compressor No. 3 1 _____ 2 _____ 3 _____
 Condenser Air Temperature In _____ Out _____
 Compressor Discharge Pressure 1 _____ 2 _____ 3 _____
 Compressor Suction Pressure 1 _____ 2 _____ 3 _____
 Refrigerant Charge O K 1 2 3

GAS HEAT

Burner Model No. _____ Serial No. _____
 *Transformer Secondary Voltage T4 _____ T4 _____
 Fuel Type _____ Pipe Size _____
 Line Pressure _____ Pilot Reg _____ Main Reg _____
 Micro Amps Pilot _____ Low Fire _____ High Fire _____
 Fan Control Setting _____
 Safety Controls Checked Combustion Blower Free & Clean
 Motor Lubrication Motor Amps _____

ELECTRIC HEAT

Model No. _____ Serial No. _____
 Voltage 1 & 2 _____ 1 & 3 _____ 2 & 3 _____
 Amps 1 _____ 2 _____ 3 _____
 Sequenced Properly

HOT WATER/STEAM

*Transformer Secondary Voltage T5 _____
 Shipping blocks removed from pump
 Lines Tight Pump Operating
 Valve Adjusted Air Bled from system

REMOTE READOUT PANEL

Switches operative: System Condensing Unit
 Manual Over-ride Timer
 Lights function properly: System Comb. Lockout
 Cond. Unit Inoperative Dirty Filter

*Refer to wiring diagrams legend for location of transformers

PREVENTIVE MAINTENANCE GUIDE

The general climatic conditions and specific application will affect service frequency.

- 1 - For climates with a heavy heat demand, an additional heating check should be made about midway through the heating season. For climates with a heavy cooling demand, an additional cooling check should be made about midway through the cooling season.
- 2 - Equipment operating under industrial or heavy duty conditions

(shopping centers, factories, etc.) will require four or more inspections per year.

- 3 - Parts should be replaced if they are found defective or show sufficient wear to indicate imminent failure.
- 4 - Filter service will vary according to the type of filter used. The frequency of filter service will vary with each unit, but must be often enough to protect the equipment and the conditioned space.

GENERAL

| SECTION | SERVICE CHECKS | PRE-HEATING SEASON | PRE-COOLING SEASON |
|-------------------------------|-----------------------------------------------------------|--------------------|--------------------|
| Electrical | Tight wire connections | X | X |
| | Check for proper fusing | X | X |
| | Contacts of compressor and motor starters | X | X |
| | Supply voltage - unit off/unit on | X | X |
| | Supply voltage - compressors on | --- | X |
| Indoor Blower & Return Blower | Shaft or bearing wear / Shaft alignment | X | X |
| | Bearing locking collars | X | X |
| | Belt tension and wear | X | X |
| | Filters | X | X |
| | Motor amps | X | X |
| | Smoke detector test | X | X |
| | Lubricate | X | --- |
| Outdoor & Return Air Dampers | Clean enthalpy control | X | X |
| | Linkage adjusted and tight | X | X |
| | Minimum air setting | X | X |
| | Exhaust damper operation | X | X |
| System Operation | A9 Load analyzer module operates properly | X | X |
| | Perform heating function test with load simulator | X | --- |
| | A4 Room sensor operation | X | X |
| | Performance cooling function test with load simulator | --- | X |
| | B12 Zone actuators operate properly | X | X |
| Gas Heat | Voltage at actuator transformers | X | X |
| | Replace burner spark plug | X | --- |
| | Clean combustion air wheels | X | --- |
| | Main line pressure / Regulator pressure | X | --- |
| | Micro-amp reading | X | --- |
| | Safety controls operate | X | --- |
| Electric Heat | Burner motor amps | X | --- |
| | Check for broken elements | X | --- |
| | Tighten all wire connections | X | --- |
| | Safety controls operate | X | --- |
| Hot Water or steam | Heater amps | X | --- |
| | Pumps operate | X | --- |
| | Valve motor operates | X | --- |
| | Leaks in system | X | --- |
| Refrigerant Cooling | Water temperature - Steam pressure | X | --- |
| | Discharge pressure, suction pressure & refrigerant charge | --- | X |
| | Hot gas bypass | --- | X |
| | Super heat setting | --- | X |
| | Pressure switches operate | --- | X |
| | Condenser fans operate | --- | X |
| | Condenser heat operates | --- | X |
| | Compressor timed interlock | --- | X |
| | Clean evaporator coil if required | --- | X |
| | Clean condensate pans and drains | --- | X |
| | Compressor amps | --- | X |
| | Condenser motor amps | --- | X |
| | Crankcase heaters | --- | X |
| Optional Controls | Valve motor operates | --- | X |
| | Leaks in system | X | X |
| | Time clock settings | X | X |
| | Nite setback operation | X | X |
| Optional Controls | Read-out panel function | X | X |

SYSTEM CONTROL

I - COMMAND SIGNAL

The basic operation of the control system is dependent upon a voltage command signal generated by each room sensor and corresponding discharge air sensor. An authority ratio of 20 to 1 exists between the discharge air sensor and the room sensor. This means a 20° temperature change across the discharge air sensor has the same magnitude as a 1° change across the room sensor. The load analyzer module provides the 24 VDC power supply to each room sensor.

These signals range from 2 VDC to 22 VDC. A 4° change across the discharge air sensor or a 0.2° change across the room sensor causes a one volt change.

Figure 29 identifies the room sensor, discharge sensor, subbase and room sensor accessories.

A - Zone Actuators

Each zone actuator receives the command signal from its respective room sensor and then modulates the dampers to satisfy the demand.

The modulating voltage range is from 10.5 VDC to 13.5 VDC. If the voltage is 10.5 volts or lower, the zone actuator positions the damper to full heating. At 12 VDC the command signal is at midpoint and both hot and cold dampers on RVZ1 are in minimum position. When voltage rises to 13.5 volts or higher, the zone actuator positions the damper to full cooling.

B - Load Analyzer Module

Command signals from room sensors feed into the load analyzer module. The module monitors the signals and selects the low and high to initiate heating and cooling modes. The zone with the lowest voltage command signal controls the heating, while the zone with the highest voltage command signal controls the cooling. Any zone may transmit the high or low signal. The load analyzer module has internal logic relays which are programmed to close a specific voltages. The "H" contacts control gas and electric heat while the "C" contacts control DX cooling.

The "HI" cooling signal controls DX cooling, the chilled water valve and power saver damper modulation through the A5 and A6 limit

controls. The "LO" heating signal controls gas heat and the hot water and steam valve modulation through the A7 limit control. Figure 30 identifies all switches and terminals on the load analyzer module.

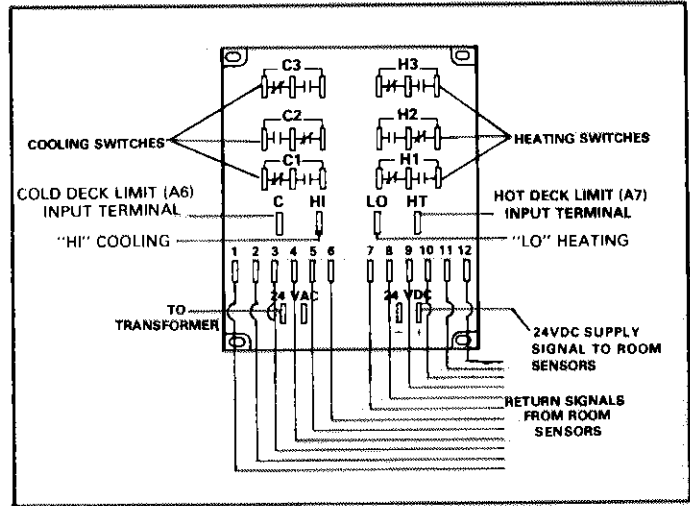
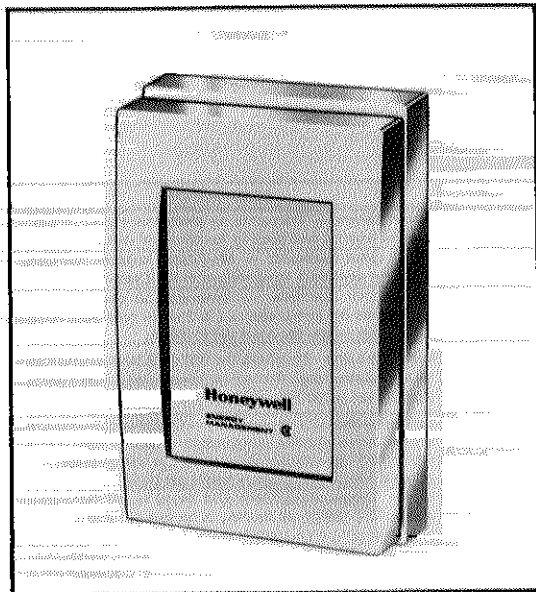

FIGURE 30

C - System Monitoring Controls

After a particular zone transmits its signal and the load analyzer determines a heating and/or cooling demand, an additional set of controls override unit operation. If these controls detect an erroneous operating condition, a combination of switches and electronic relays are programmed to return unit into the desired operation. Table 2 lists these overriding controls and Figure 31 illustrates a typical flow chart for the control system. Refer to individual heating and cooling sections for additional information on monitoring controls.

NOTE - The overriding limit controls (A5, A6 and A7) generate limit



ROOM TRANSMITTER

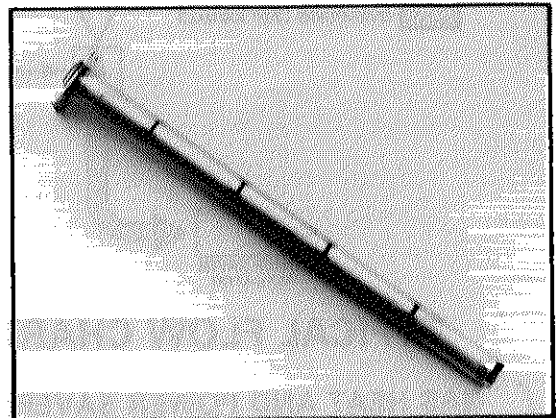

DISCHARGE AIR SENSOR

FIGURE 29

signals based on deck temperatures. They do not initiate the demands, but must approve the A9 command signals before the unit goes into normal operation.

II - LOAD SIMULATOR

A load simulator (66C04001) is used to check system operation. The load simulator produces a signal ranging from 2 volts thru 22 volts to simulate a zone demand in the electronic circuits. Refer to the individual heating and cooling sections for the complete heating or cooling checkout.

NOTE - The load simulator may cause a shift of + 1 volt from settings on function charts. Any variation in starting points should be consistent.

Use the following steps to connect load simulator.

- 1 - Turn off power to unit.
- 2 - Disconnect the (+) wire which runs from terminal strip TB-Z to 24 VDC terminal at A9 module.

NOTE - On units with condenser heat, the discriminator function will close the outside dampers to minimum position.

- 3 - Connect load simulator as shown in Figure 32. Null simulator by aligning thumbwheel mark with null indicator.

TABLE 2

| SYSTEM MONITORING CONTROLS | | |
|----------------------------|----------------------------------|------------------------|
| KEY | DESCRIPTION | LOCATION |
| A5 | No. 1 Limit Controller (PS) | main control box |
| A6 | No. 2 Limit Controller (DX Cool) | main control box |
| A7 | Hot Deck Limit | main control box |
| K72 | Lo Temperature Relay | main control box |
| K73 | Upper Temperature Relay | main control box |
| K74 | Stage 1 Heat Relay | main control box |
| K77 | Set Point Relay | compressor control box |
| RT13 | Cold Deck Power Saver Thermistor | cold deck |
| RT14 | Cold Deck DX Cool Thermistor | cold deck |
| RT15 | Hot Deck Thermistor | hot deck |
| S42 | Lo Temperature Limit | dampner compartment |
| S43 | Upper Temperature Limit | dampner compartment |

- 4 - Turn on power to unit. Check heating or cooling operation according to the appropriate section within this manual.

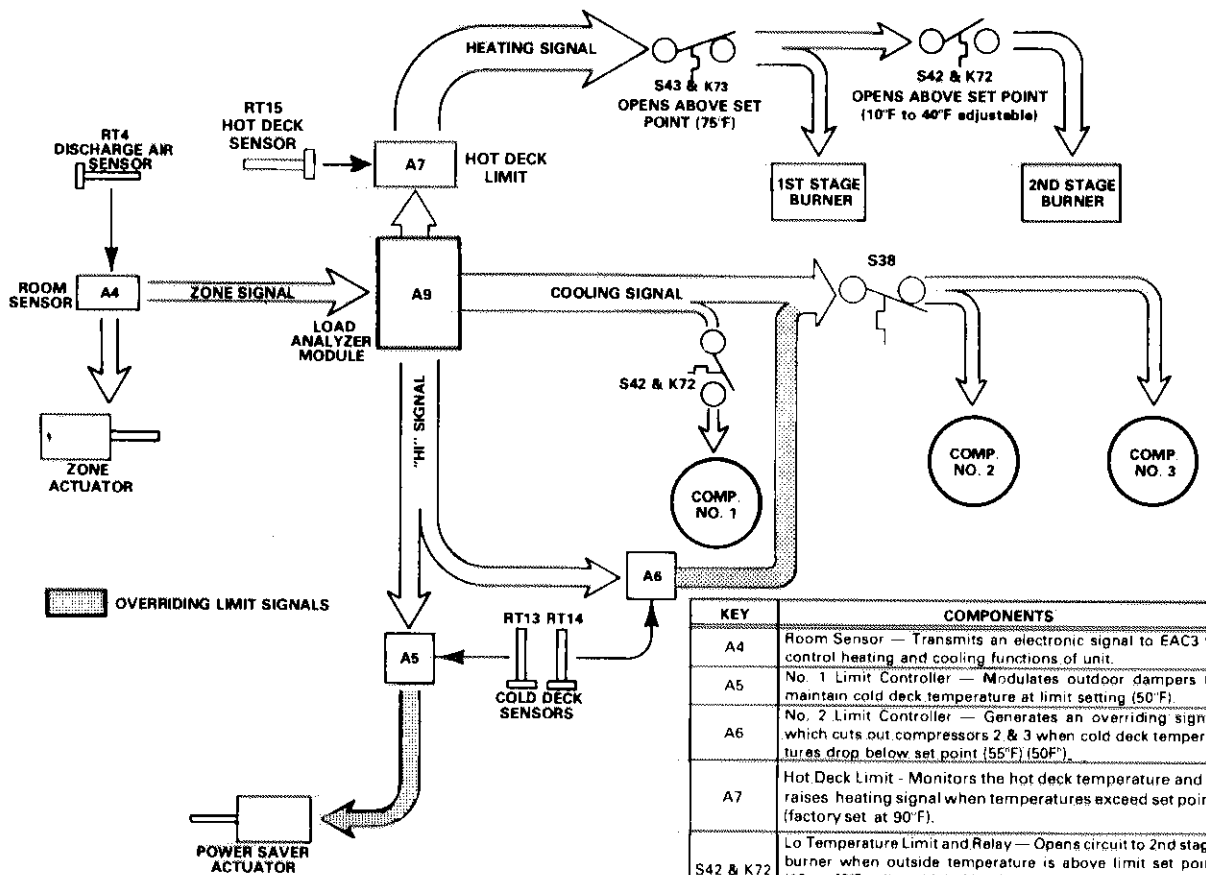

TYPICAL FLOW CHART

(GAS HEAT AND POWER SAVER LESS CONDENSER HEAT AND DISCRIMINATOR)

| KEY | COMPONENTS |
|-----------|---------------------------------------------------------------------------------------------------------------------------------------------------------------------------------------------------------------------------|
| A4 | Room Sensor — Transmits an electronic signal to EAC3 to control heating and cooling functions of unit. |
| A5 | No. 1 Limit Controller — Modulates outdoor dampers to maintain cold deck temperature at limit setting (50°F). |
| A6 | No. 2 Limit Controller — Generates an overriding signal which cuts out compressors 2 & 3 when cold deck temperatures drop below set point (55°F) (50°F). |
| A7 | Hot Deck Limit - Monitors the hot deck temperature and raises heating signal when temperatures exceed set point (factory set at 90°F). |
| S42 & K72 | Lo Temperature Limit and Relay — Opens circuit to 2nd stage burner when outside temperature is above limit set point (10 to 40°F adjustable). Also locks out compressor 1 when outside temperature drops below set point. |
| S43 & K73 | Upper Temperature Limit and Relay — At temperatures above 75°F (24°C), all heating is locked out and "Hi" speed is locked out on 1,6 compressors. |
| RT4 | Discharge Air Sensor — Senses discharge air temperature to reposition zone damper in anticipation of the effect on room temperature. |
| RT13 | Cold Deck Power Saver Thermistor — Senses cold deck temperature for A5. |
| RT14 | Cold Deck DX Cool Thermistor — Sense cold deck temperature for A6. |
| S38 | Compressor Monitor - Locks out compressors when outdoor temperature falls below setpoint. |

FIGURE 31

SYSTEM CONTROL

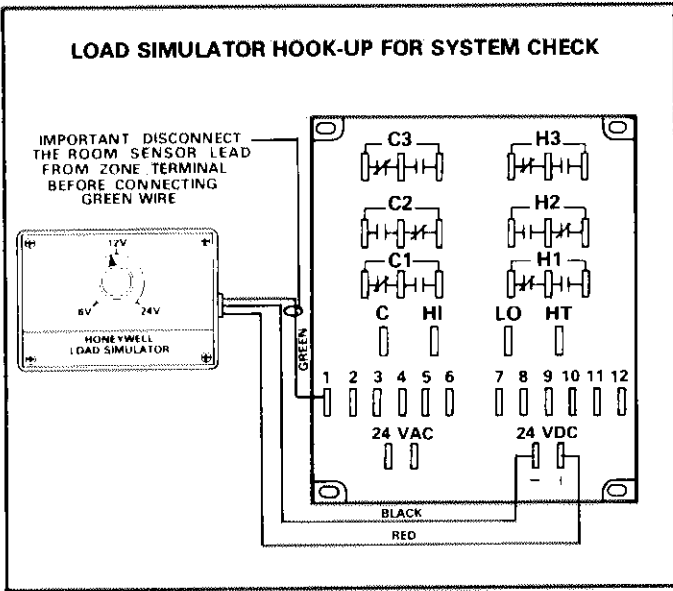
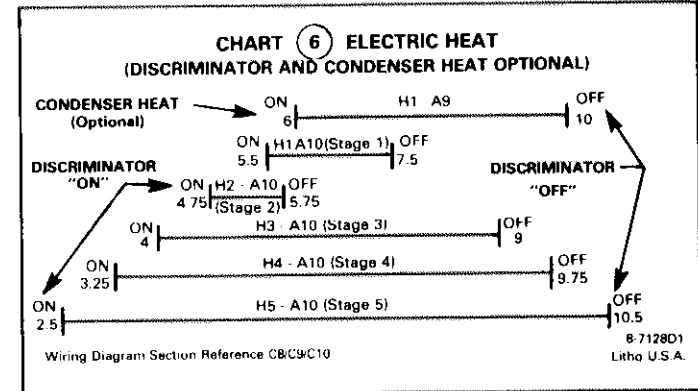
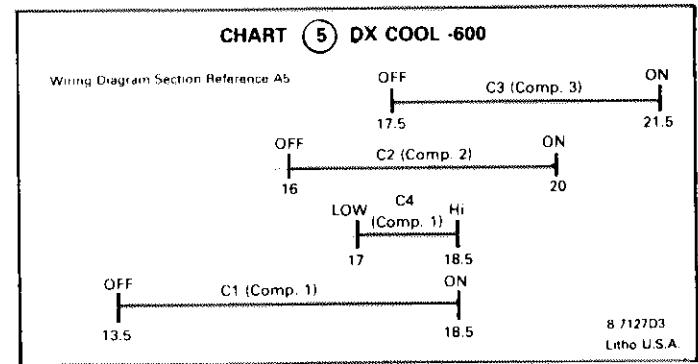
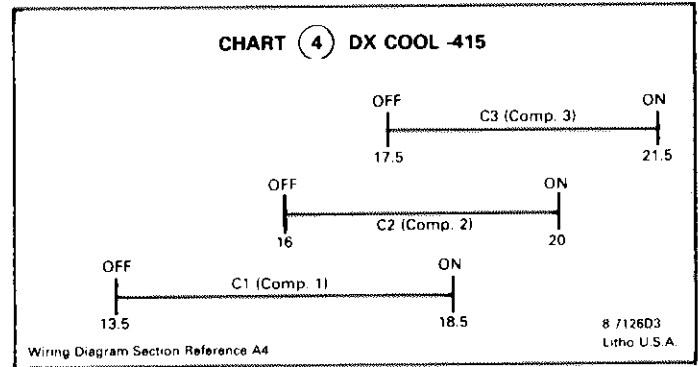
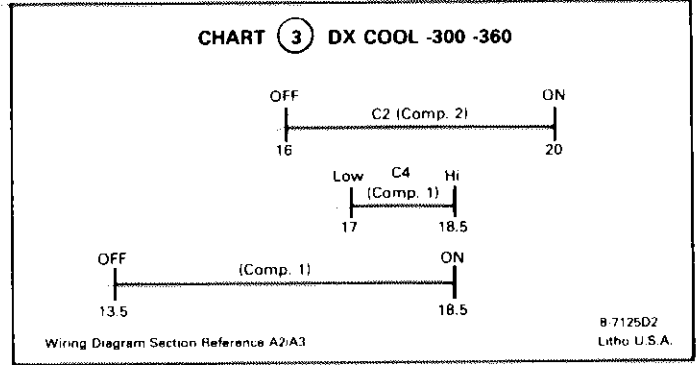
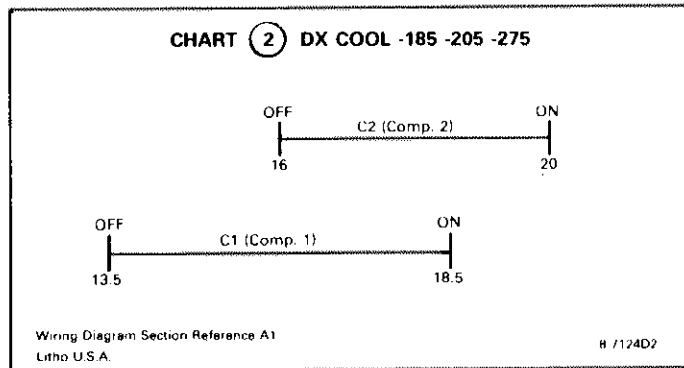
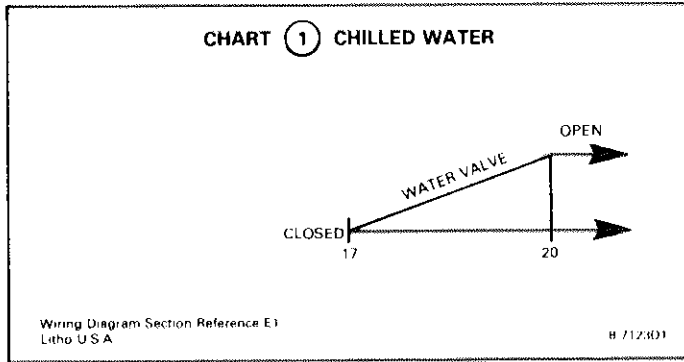

FIGURE 32

III - FUNCTION CHARTS

The correlation between the command signal voltage and the unit sequence of operation is illustrated in chart form. A basic function chart is provided on page 36 on which individual function charts are overlaid to give a complete unit operating sequence. These individual function charts (totaling 10) are contained on a separate sheet in the manual. Refer to decision tree on page 37 to select the charts that apply to your unit. A corresponding function chart is also supplied with each unit.

All function charts are listed below. Refer to each heating and cooling section for a detailed explanation of the corresponding function chart.



SYSTEM CONTROL

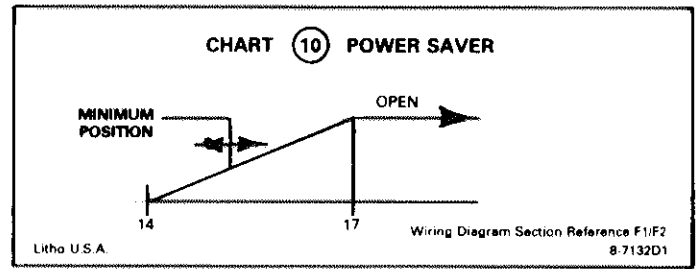
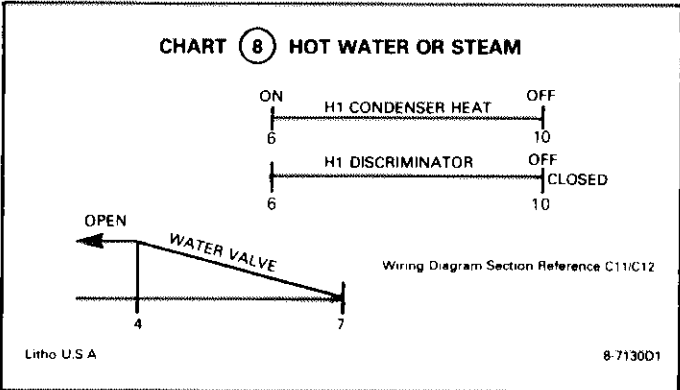
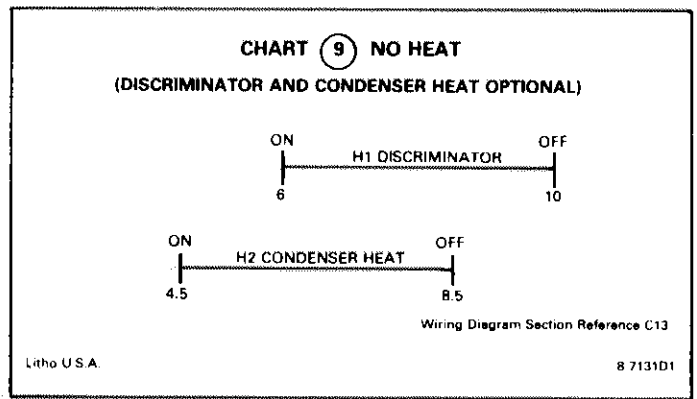
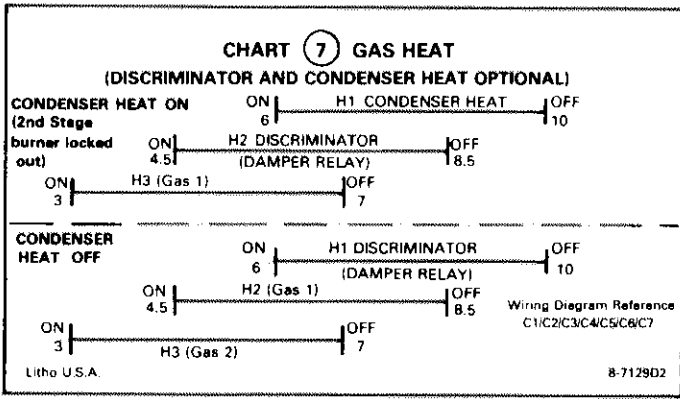
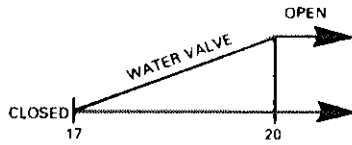

CHART 1 CHILLED WATER



Wiring Diagram Section Reference E1
Litho U.S.A.

8 7123D1

CHART 2 DX COOL -185 -205 -275

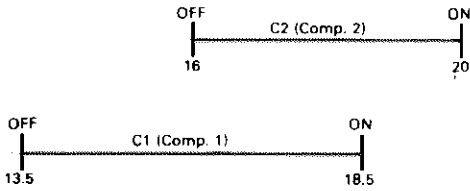

Wiring Diagram Section Reference A1
Litho U.S.A.

8-7124D2

CHART 3 DX COOL -300 -360

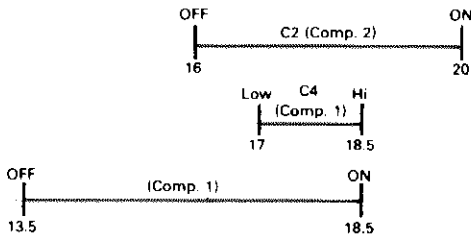

Wiring Diagram Section Reference A2/A3

8-7125D2
Litho U.S.A.

CHART 4 DX COOL -415

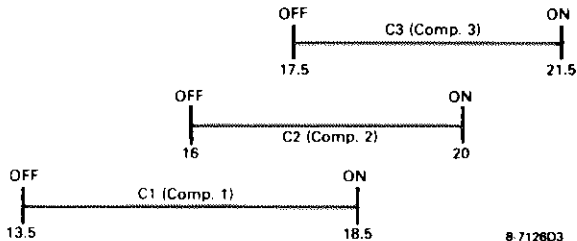

Wiring Diagram Section Reference A4

8-7128D3
Litho U.S.A.

CHART 5 DX COOL -600

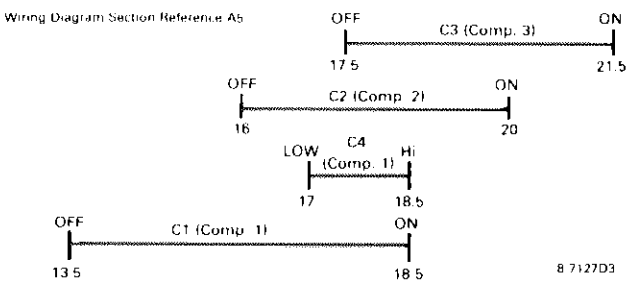

Wiring Diagram Section Reference A5

8-7127D3
Litho U.S.A.

**CHART 6 ELECTRIC HEAT
(DISCRIMINATOR AND CONDENSER HEAT OPTIONAL)**

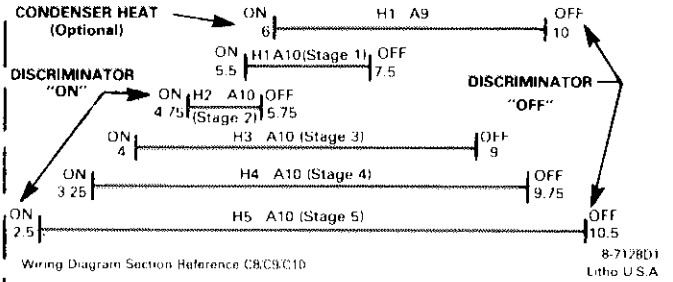

Wiring Diagram Section Reference C8/C9/C10

8-7128D1
Litho U.S.A.

**CHART 7 GAS HEAT
(DISCRIMINATOR AND CONDENSER HEAT OPTIONAL)**

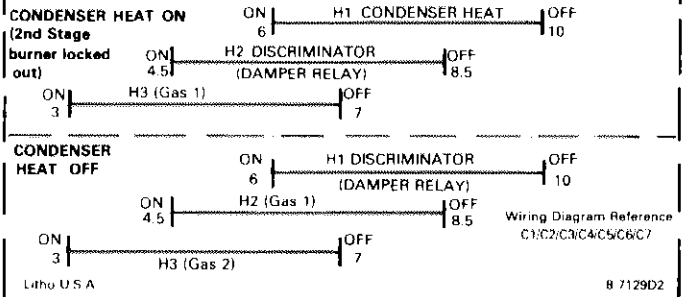

Wiring Diagram Reference C1/C2/C3/C4/C5/C6/C7

Litho U.S.A.

8-7129D2

CHART 8 HOT WATER OR STEAM

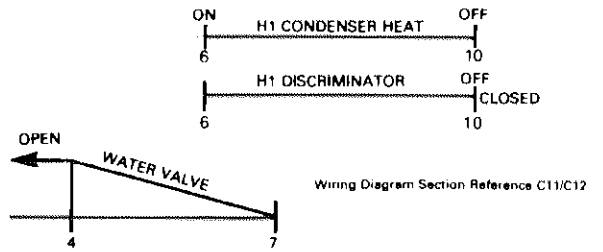

Wiring Diagram Section Reference C11/C12

Litho U.S.A.

8-7130D1

**CHART 9 NO HEAT
(DISCRIMINATOR AND CONDENSER HEAT OPTIONAL)**

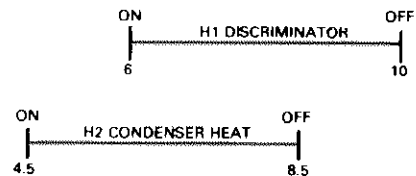

Wiring Diagram Section Reference C13

Litho U.S.A.

8-7131D1

CHART 10 POWER SAVER

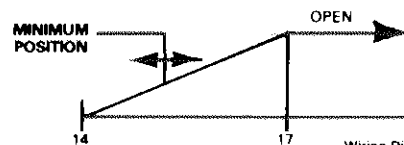

Wiring Diagram Section Reference F1/F2
8-7132D1

Litho U.S.A.

BASIC FUNCTION CHART

HEATING DAMPER
OPEN



COOLING DAMPER
OPEN



CHARTS 1, 2, 3, 4, OR 5

CHARTS 6, 7, 8 OR 9

CHART 10

Litho U.S.A.

8-7122D2

FUNCTION DECISION TREE

COOL

HEAT
(DISCRIMINATOR AND CONDENSER HEAT INCLUDED)

POWER
SAVER

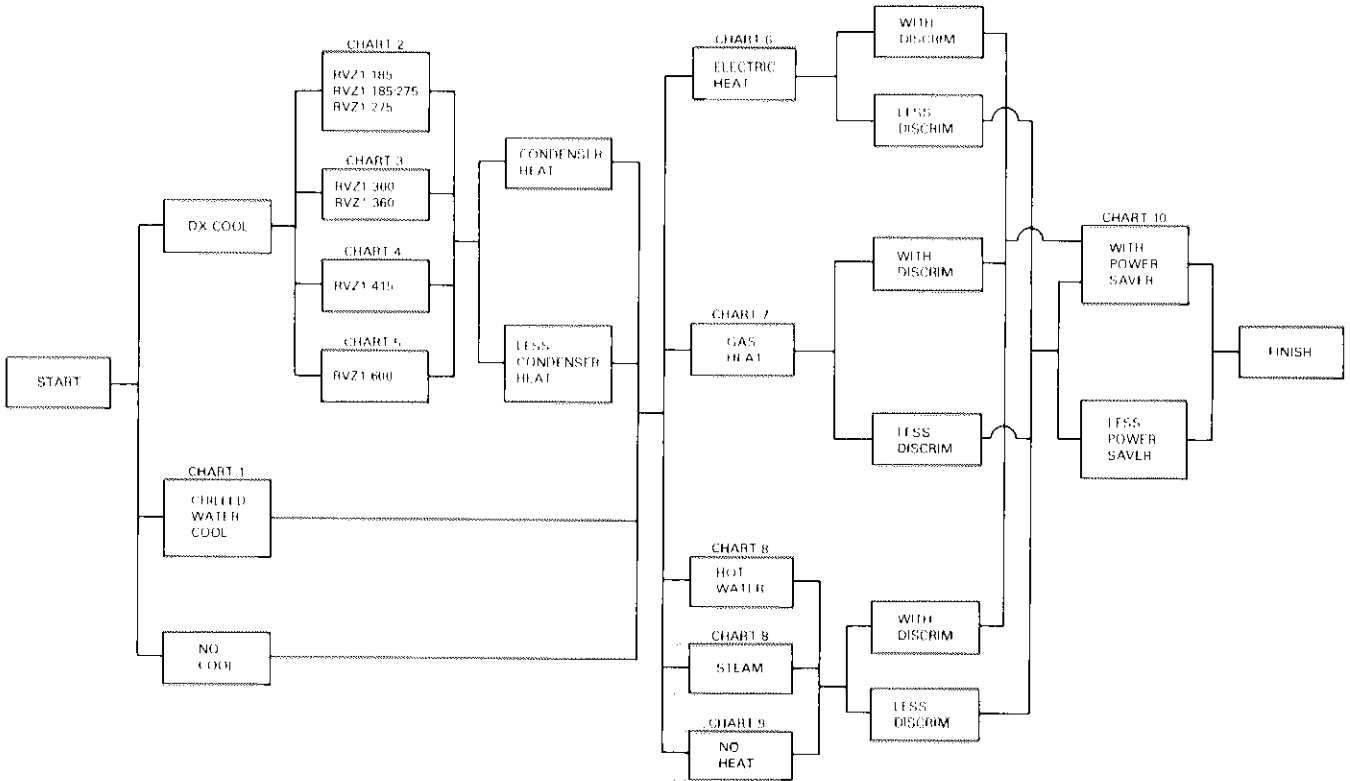

ROOM SENSOR

DISCHARGE AIR SENSOR TEMPERATURE DEVIATION FROM SET POINT

-40°F 32°F 24°F 16°F 8°F 0°F 0°F 8°F 16°F 24°F 32°F +40°F

ROOM SENSOR TEMPERATURE DEVIATION FROM SET POINT

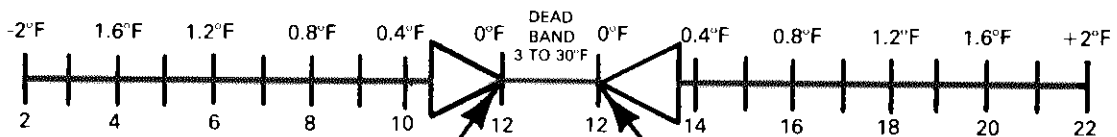

COOL SET POINT HEAT SET POINT

COMMAND SIGNAL DC VOLTAGE

FIGURE 33

IV - ROOM SENSOR CHECKS

A - Voltage Signal

The command signal voltage is the algebraic sum of the room sensor and discharge air sensor (RT4). This sum reflects the temperature deviations from set point. A 4° change across the discharge air sensor or a 0.2° change across the room sensor each cause a one volt change. Figure 33 illustrates the correlation between temperature changes and voltage signal for both standard room sensor and "no load band" room sensor.

B - Performance Check

A DC voltmeter must be used for the following check.

CAUTION - The thermistor will change its resistance in response to changes in temperatures. When making set point adjustments, keep hands and other heat sources away from thermistor.

- 1 - Remove cover from room sensor. Connect voltmeter to terminals 3 (—) and 4 (+). See Figure 34.
- 2 - Slowly increase heating (red lever) set point 5 degrees above room temperature. The voltage should decrease to approximately 2 VDC before set point is 5 degrees above room temperature.
- 3 - Slowly decrease cooling (blue lever) set point 5 degrees below room temperature. The voltage should increase to approximately 22 VDC before set point is 5 degrees below temperature.

4 - Refer to "Electronic Circuit Troubleshooting" section on page 39 if command voltage does not respond to set point adjustments.

5 - Table 3 lists the voltage ranges that reflect conditions at room sensor. Refer to Figure 34 for meter connections.

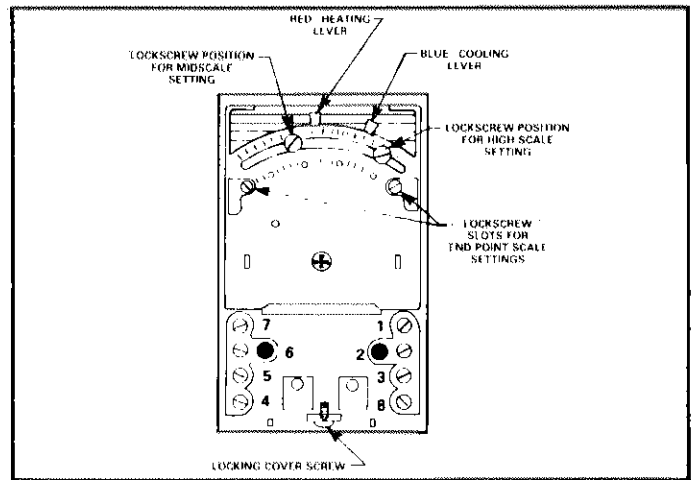

FIGURE 34

TROUBLE SHOOTING CHART

| PROBLEM | POSSIBLE CAUSES | ELIMINATION PROCEDURE |
|----------------------------------------------------------------------------------------------------------------------------------------------------------------------------------------------------------------------------------------------------------------|-------------------------------------------------------------------------------------------------------|------------------------------------------------------------------------------------------------------------------------------------------------------------------------------------------------------------------------------------------------------------------------|
| No. DC Power at terminals marked 24 VDC | No AC Power. | Check T10 transformer. |
| | Room Sensor wires 2 and 3 shorted or reversed on one or more zones. | Correct short or reverse leads. |
| DC Power reads constant low voltage (Approx. 2 to 6 Volts) at terminals marked 24 VDC. | Room Sensor wires 2 and 4 shorted or reversed on one or more zones. | Disconnect Room Sensor wire No. 3 from "Z" terminal strip. If meter reads 24 Volts DC, then Room Sensor wires 3 and 4 are shorted. If meter reads a constant low voltage (2 to 6 Volts), then Room Sensor wires 2 and 4 are shorted. |
| | Room Sensor wires 3 and 4 shorted or reversed on one or more zones. | Disconnect the No. 1 Actuator wires from terminal strips "Z" and "F" until DC power is restored. |
| | Zone Actuator or Power Saver Actuator terminals 1 and 6 are shorted or reversed on one or more zones. | Replace Room Sensor. |
| A9 Output Voltages: Constant zero (0) Volts: Minus (—) DC terminal to HI. Minus (—) DC terminal to LO. Constant 2 to 6 Volts Minus (—). DC terminal to LO (heating). Constant 22 Volts Minus (—) DC terminal to HI (cooling). | Power Saver Actuator or wiring shorted. | Disconnect command wire from terminal marked HI on A9 Load Analyzer Module. If meter reads a command signal, then the Power Saver Actuator or wiring is shorted. |
| | Motorized Valve or wiring shorted. | Disconnect command wire from terminal marked LO on A9 Control Module. If meter reads a command signal, then the motorized valve or wiring is shorted. |
| | Room Sensor wire 2 open on one or more zones. | Connect voltmeter between minus (—) 24 Volt DC terminal to each of the terminals marked ZONES. This will locate the zone(s) reading a constant 2 to 6 Volts. Once the zone(s) has been located, check the field wiring between the terminal strip "Z" and Room Sensor. |
| | Room Sensor wire 3 opens on one or more zones. | Connect voltmeter between minus (—) 24 Volt DC terminal to each of the terminals marked ZONES. This will locate the zone(s) reading a constant 22 volts. Once the zone(s) has been located, check the field wiring between the terminal strip "Z" and Room Sensor. |
| Heating equipment does not operate when command voltage is (+) 2 Volts DC (full heating). Minus (—) DC terminal to LO. | Heating relays H1, H2 or H3 damaged. | Consecutively jumper H1, H2 and H3 heating relays. If all heating functions operate, the appropriate relay is damaged. Replace the A9 Load Analyzer Module. |
| Cooling equipment does not operate when command voltage is (+) 22 Volts DC (full cooling). Minus (—) DC terminal to HI. | Cooling relays C1, C2 or C3 damaged. | Consecutively jumper C1, C2, C3 and C4 cooling relays. If all cooling functions operate, the appropriate relay is damaged. Replace the A9 Load Analyzer Module. |
| Individual zone temperature running approximately four (4) degrees below set point. | Thermostat or Transmitter wires 1 and 3 shorted Duct Temperature Sensor shorted. | Correct short. |
| Individual zone temperature running approximately four (4) degrees above set point. | Room Sensor wire 1 open. | Connect lead. |
| | Room Sensor wires 1 and 2 shorted. | Correct short. |
| | Discharge Air Sensor open. | Connect lead. |

SYSTEM CONTROL

TABLE 3

| Room Sensor | Correct Voltage |
|---------------------------------------------------------------------------------------------|------------------------------------------------------------------------------------|
| DC Power Supply Terminals 2 (+) and 3 (-) | 24 VDC |
| TR1 Discharge Sensor (Adjust set point to room temperature) Terminals 1 (+) and 3 (-) | 6 VDC to 18 VDC (Depending on duct temperature) |
| Command Voltage Terminals 3(-) and 4 (+) | 2 VDC to 22 VDC (Varies with difference between set point and room temperature) |

V - ELECTRONIC CIRCUIT TROUBLESHOOTING

The Troubleshooting Chart on page 38 will assist the serviceman in locating possible wiring problems. These checks are additions to the heating or cooling checks given in each section. The recommended troubleshooting procedure is one of eliminating symptoms by disconnecting a possible short on a single zone basis until the symptom is eliminated. These checks are made at the A9 load analyzer module.

NOTE - Make certain all room sensor frames are snug against sub-base.

VI - REMOTE CONTROL OPTIONS

A - Smoke Detectors

Photo cell smoke detectors detect smoke within the system and terminate unit heating and cooling upon the presence of smoke. Blowers and dampers are controlled by 1 of 4 options as described in Figure 19 on page 13. Two detectors are used; one next to the return air dampers and another in the blower compartment downstream from air filters. Each detector has a built-in key operated test feature. In addition, two remote test stations may be used (one per detector). Refer to Figure 36 for smoke detector description and test procedure.

The smoke detectors are equipped with terminals for remote alarm and trouble circuit hook-ups.

- 1 - Trouble relay contacts (terminals 8 & 9) are normally open (closed during unit operation). A typical trouble circuit would incorporate a system light that would be "ON" during normal unit operation and would go "OFF" with the presence of smoke.
- 2 - Alarm contacts (terminals 6 & 7) are normally closed (open during unit operation). An alarm, telephone or buzzer would be energized with the presence of smoke.

Maintenance

Clean the smoke detector sensing chamber at least once a year and more often when abnormal accumulations are noted on the outer filter. See Figure 36 for cleaning instructions.

CAUTION - Turn off power before servicing or the alarm may be activated (if used). Cleaning should be performed in subdued light for minimum reset time.

- 1 - Remove cover from detector.
- 2 - Disconnect wiring harness and light from sensing chamber.
- 3 - Remove chamber mounting screws and draw assembly straight out from detector.
- 4 - Remove chamber outer filter and rinse in a solution of warm water and mild detergent. Allow to air dry.
- 5 - Remove nuts and washers from front of chamber plate and draw cage straight out from plate using caution to avoid any damage to the assembly. Remove chamber plate gasket.
- 6 - Clean cage inner filter by vacuum or air pressure. This filter is cemented to the cage and must not be removed. If filter is loose contact cement may be used to resecure it.
- 7 - Clean the optical block and surrounding surfaces with air pressure, vacuum, or with a soft cloth if necessary. Clean all dust and lint from holes and lens in optical block as these could cause a false alarm.
- 8 - Install gasket on cage and secure cage to chamber plate with the washers and nuts.
- 9 - Install outer filter on cage and install chamber assembly to detector base with the mounting screws.

- 10 - Connect wiring harness and light to sensing chamber.
- NOTE - If the photocell was exposed to light during cleaning, the alarm (if used) will go on unless the power at unit was turned off.*
- 11 - Install detector cover and turn detector key switch to RESET position. Connect unit power.
- NOTE - A reset period of up to one half hour may be required depending on the amount of light the photocell was exposed to during servicing.*
- 12 - After resetting the detector, turn detector key switch to the NORMAL position.
 - 13 - Allow detector to remain powered for one hour after resetting, then test detector using standard test procedure.
 - 14 - Return system to normal operation.

NOTE - If unit is used for temporary heat during construction, smoke detector sensing chambers should be removed as large amounts of fine construction dust may cause a false alarm. A sensing chamber from one detector should not be placed in another detector, since they were each calibrated as a complete unit before leaving the factory.

B - Night Setback Controls

Night setback and override controls are designed for use in conjunction with a clocktimer. When system clocktimer shuts unit down for night operation, the control of unit is automatically switched from the day thermostat to the night thermostat which will maintain a lower room temperature. The optional clocktimer may be ordered factory installed in the compressor compartment of the unit or ordered separately and field installed remote from unit. Night setback kit with manual 12 hour timer (in readout panel) will return system to normal daytime conditions by setting clock for desired length of time. When time expires and timer is at original position, the system will return to nighttime control. Night setback kit with manual switch works the same way the manual timer kit works, except the manual switch must be turned off to return system to nighttime control. See Figure 35.

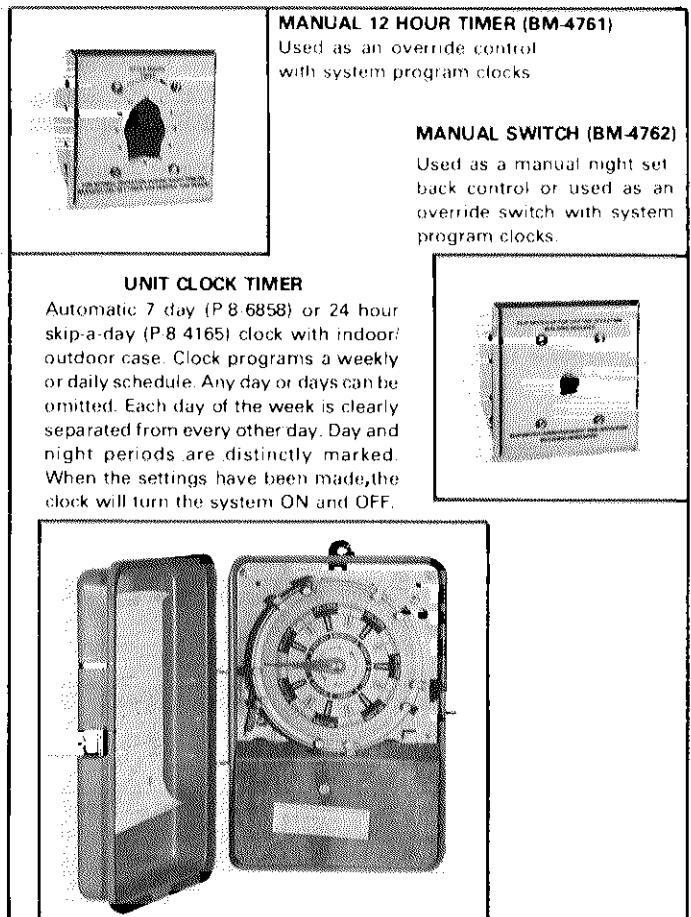
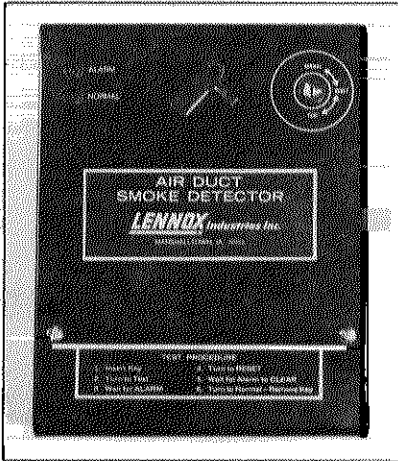
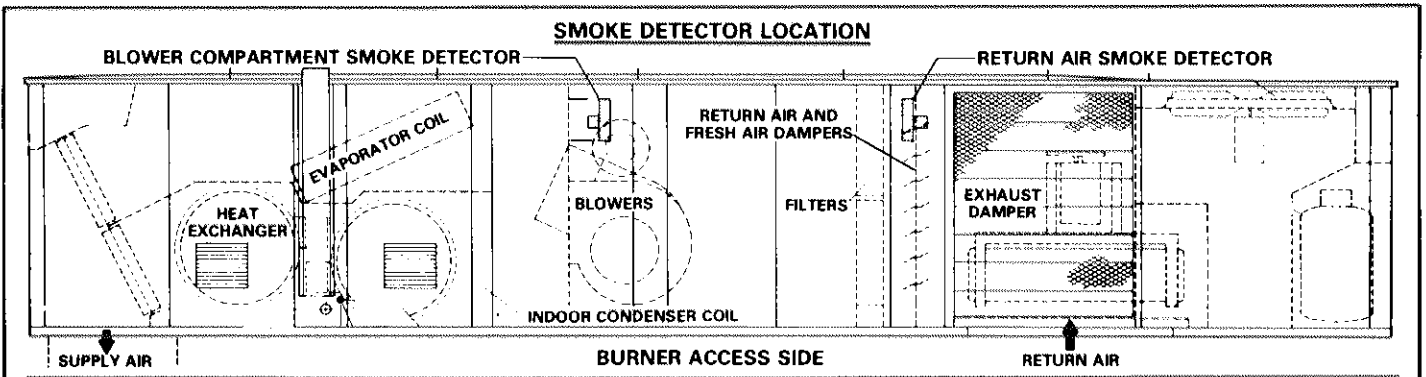

FIGURE 35

SYSTEM CONTROL



**SMOKE DETECTOR
(2 IN UNIT)**

TEST PROCEDURE

- 1 - Insert key and turn to TEST.
- 2 - Unit heating/cooling functions will terminate and blower/damper operation will respond.
- 3 - Turn to RESET. Wait for unit blower to start.
- 4 - Turn to NORMAL (green light on). Remove key.

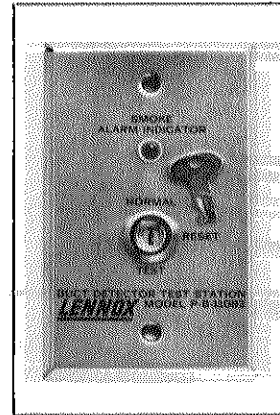

**REMOTE TEST STATION
(2 REQUIRED)**

TEST PROCEDURE

- 1 - Insert key and turn to TEST.
- 2 - Wait for indicator lamp (red) to light. Check for units response.
- 3 - Turn to RESET. Wait for indicator lamp to go off and that unit blower starts.
- 4 - Turn key to NORMAL. Remove key.

NOTE - All key switches must be left in the "NORMAL" position.

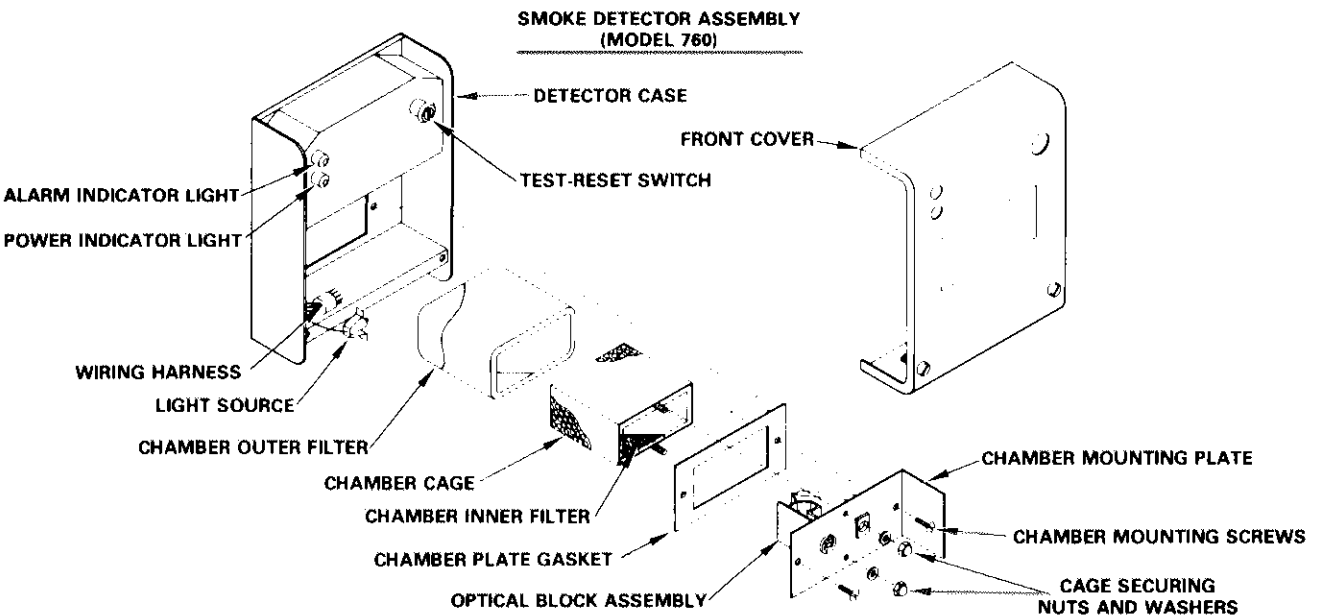

FIGURE 36

SYSTEM CONTROL

C - Sandstorm Switch (S17)

The remote sandstorm switch (BM-7262) closes outside air dampers when switch is in "down" position. When switch is in "up" position it allows normal damper operation. Refer to Figure 37.

D - Lennox RP2 Remote Readout Panel

Remote readout panel is designed to show at a glance operation of equipment. A green light is provided for system operation and three red lights for combustion lockout, condensing unit malfunction and dirty filter. In addition, the readout panel contains a system switch for shutting down equipment, an after hours timer to be used for

after hours occupancy and a switch for shutting off DX cooling. The three red lights on panel are equipped with push button switches for checking the light bulbs. In addition, the combustion lockout energizes phone or service relay as light is energized. Refer to Figure 38 for readout panel identification.

SYSTEM CONTROL

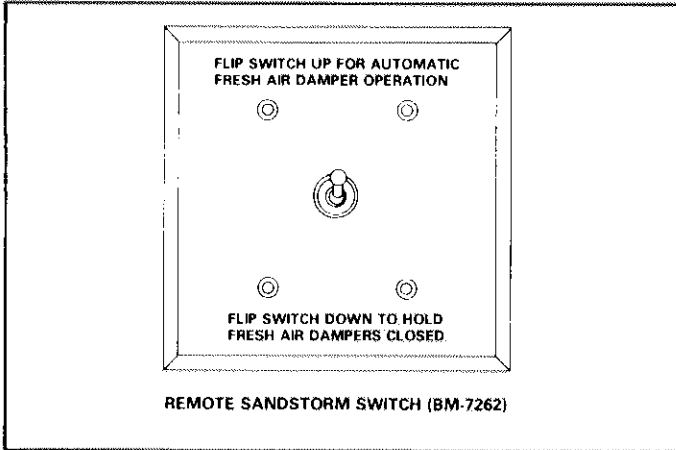

FIGURE 37

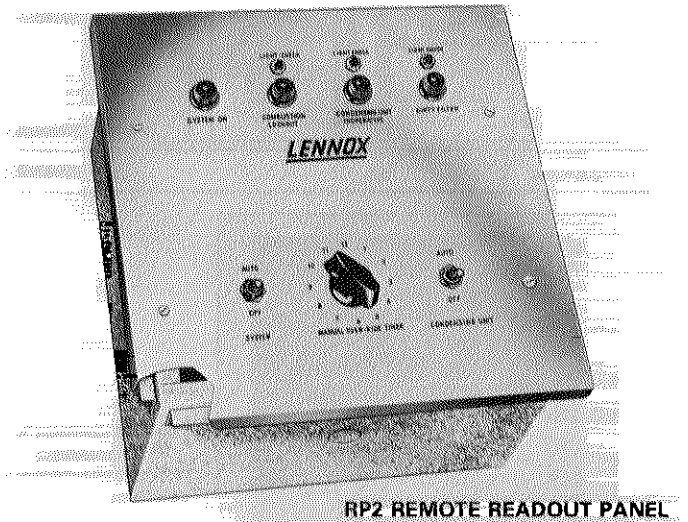

FIGURE 38

GAS HEAT

I - GAS HEAT SECTION

A - Gas Heating Compartment Identification

Refer to Figure 39 for locations of gas components.

B - Manifold Piping

Refer to the piping manifold schematics in Figure 40 for location of the manual shut-off valve(s) and regulators for the natural and propane gas options.

II - GAS HEAT CONTROLS

A - GX3 Burner

Table 4 lists the sizes available with the number of burners and corresponding Btuh values. Figure 41 identifies the GX3 power burner.

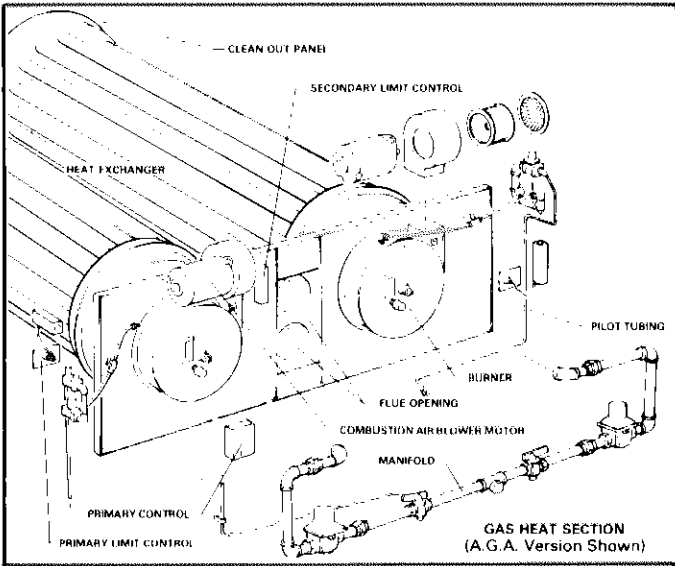

FIGURE 39

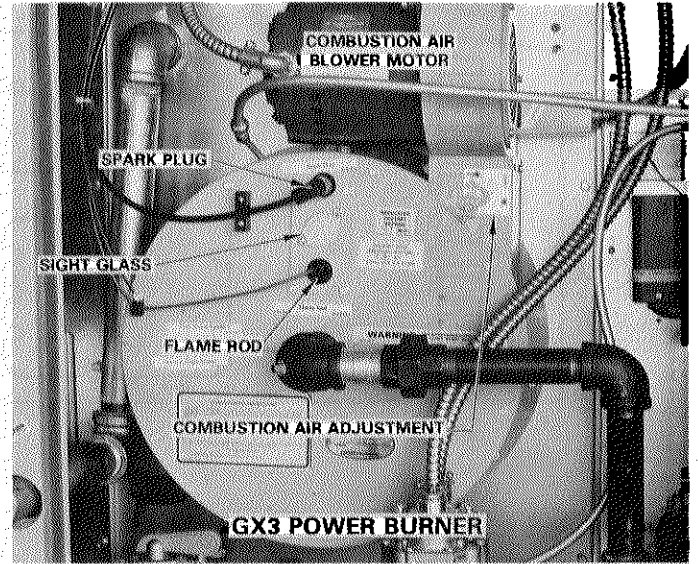

FIGURE 41

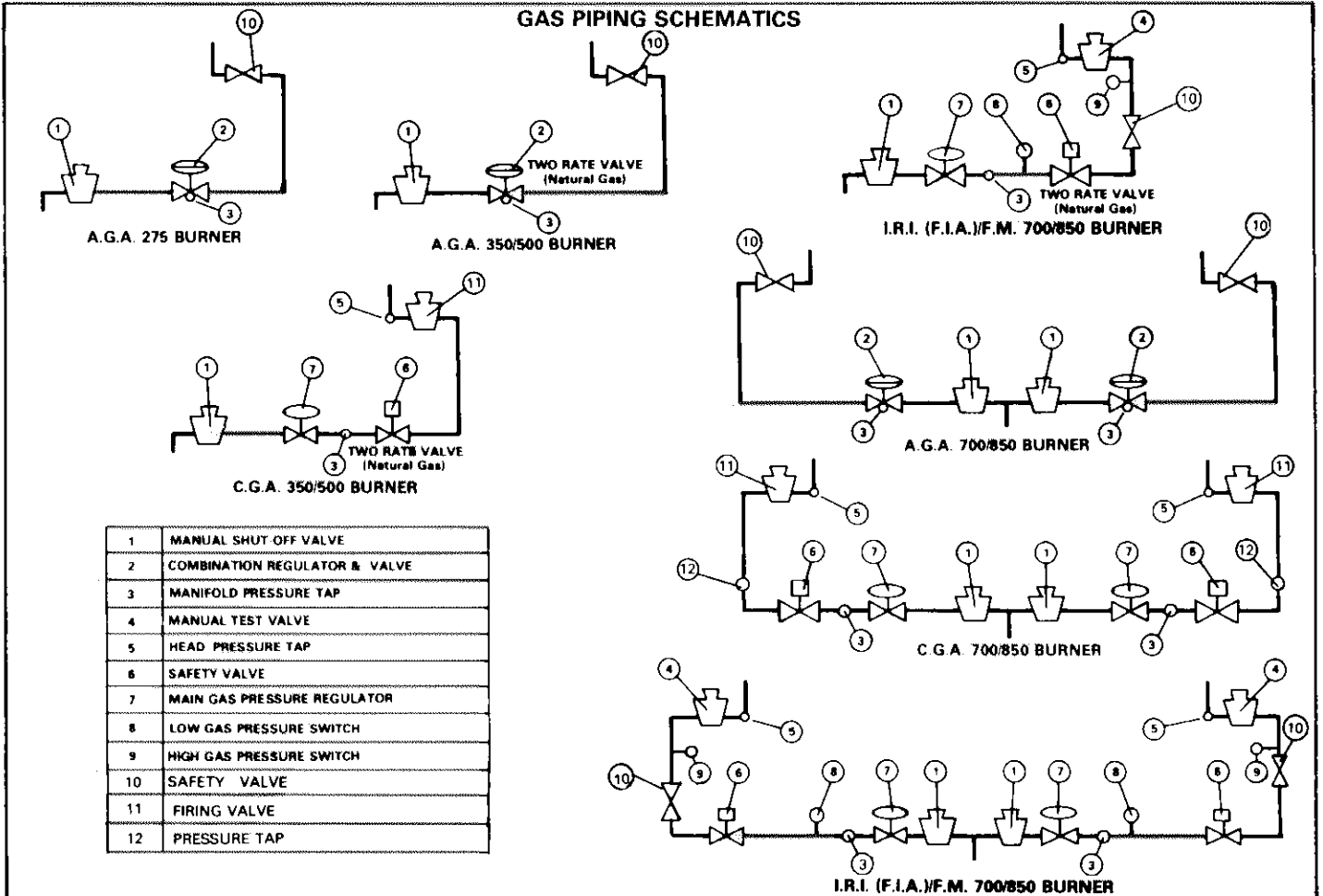
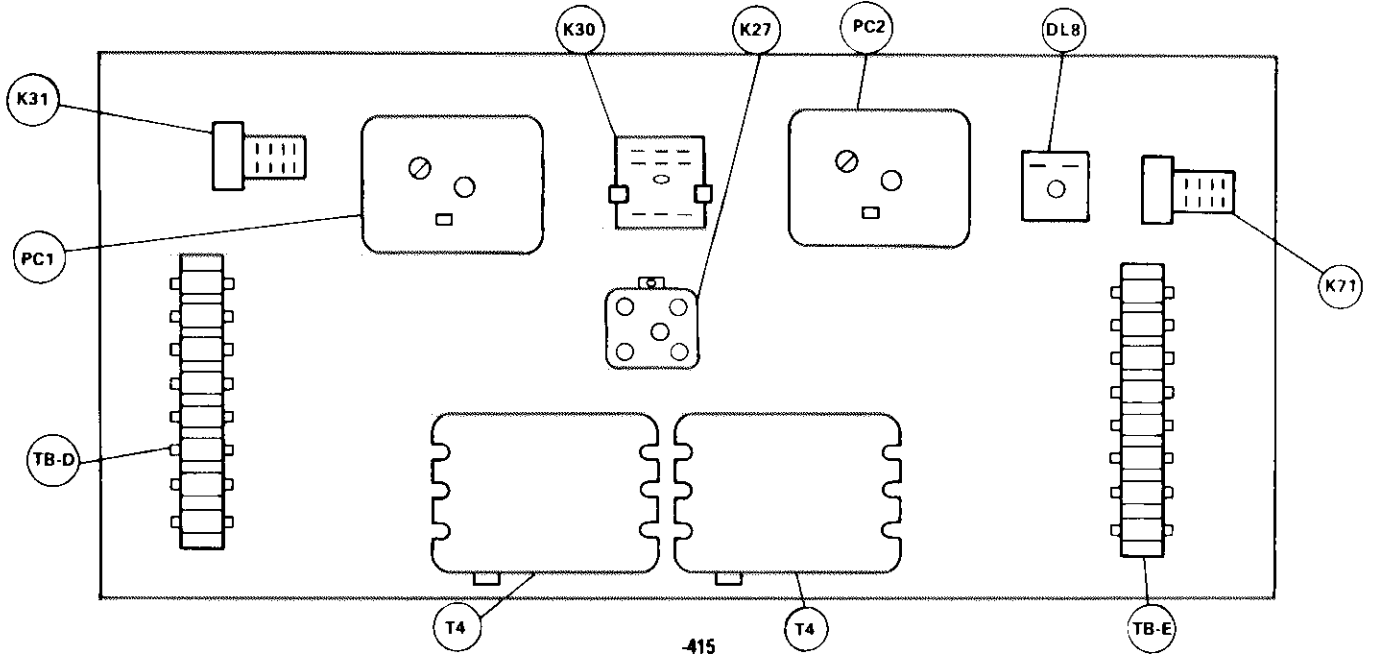

FIGURE 40

HEATING CONTROL BOX

185, 205, 275, 300, 360



-415
-600

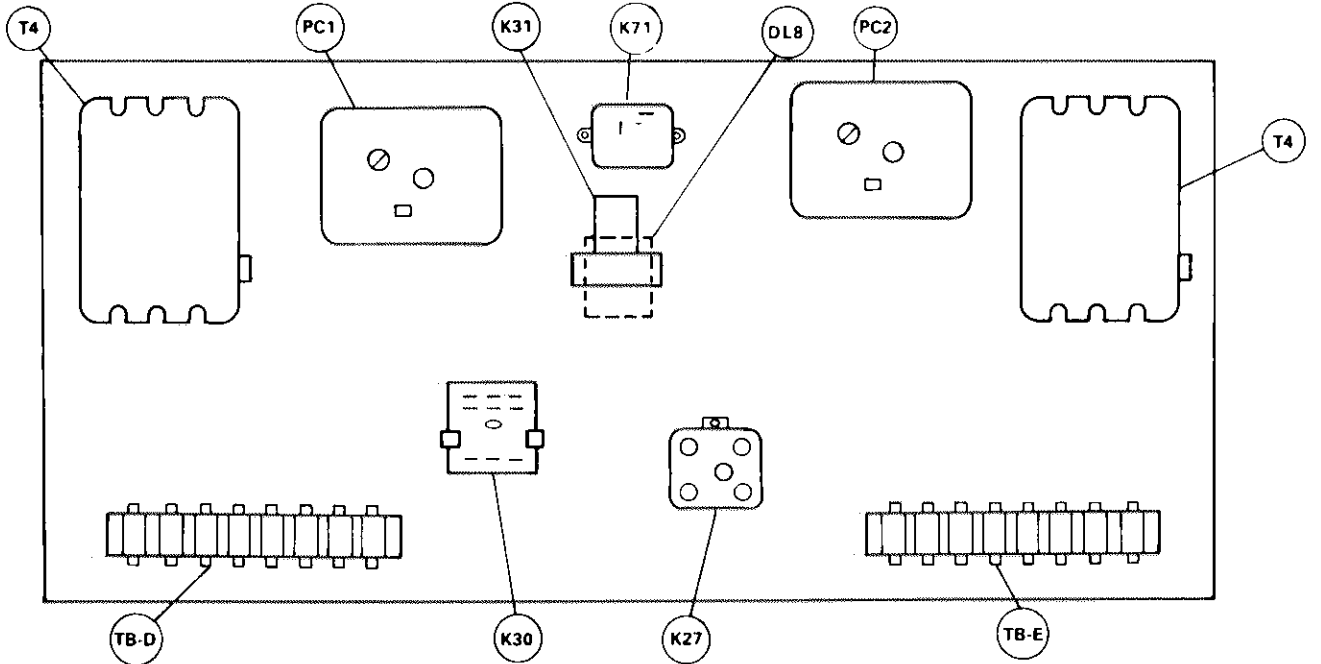

| KEY | DESCRIPTION |
|------|---------------------------------------|
| DL8 | solid state delay relay (R4795D only) |
| K27 | combustion air relay |
| K30 | transfer relay |
| K31 | pre-purge relay (RA890F only) |
| K71 | burner relay (R4795 only) |
| PC | primary control |
| T4 | ignition transformer |
| TB-D | terminal block "D" |
| TB-E | terminal block "E" |

HEATING CONTROL BOX

TABLE 4

| Heating Capacity | Gas Type | Number of Burners | Staging | |
|------------------|-------------------|-------------------|-----------|-----------|
| | | | 1st Stage | 2nd Stage |
| 275,000 | Natural | 1 | 275,000 | --- |
| 350,000 | Propane | 1 | 350,000 | --- |
| 350,000 | Natural | 1 | 250,000 | 100,000 |
| 500,000 | Natural & Propane | 1 | 320,000 | 180,000 |
| 700,000 | Natural & Propane | 2 | 350,000 | 350,000 |
| 850,000 | Natural & Propane | 2 | 350,000 | 500,000 |

B - Primary Controls

Three types of primary controls are available; RA890, R4795D, and LFA 1.63 (50 Hz) only. A high gas pressure switch, a low gas pressure switch, and a time delay circuit in first stage of heat are included with the R4795D option for I.R.I. and F.M. systems. Each burner has its respective primary control. Figure 42 locates the primary control for a 185/205/300/360. On 415/600 units, the reset buttons are located on the vestibule panel.

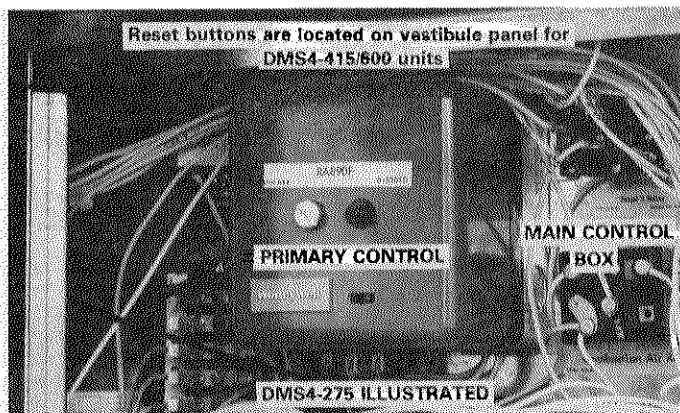

FIGURE 42

C - Units With Condenser Heat

A transfer relay (K30) and stage H1 are used with condenser heat. This relay is programmed to close at a specific voltage to initiate a condenser heat demand. See Function Chart. If H1 is closed, compressor 1 operation energizes K30 which then shifts the unit into condenser heat and first stage gas heat. With compressor 1 off, unit returns to first and second stage of gas heat. Figure 43 illustrates the staging with condenser heat both "on" and "off". For additional information on condenser heat, refer to page 65.

III - SEQUENCE OF OPERATION (Function Chart Voltage)

The following chart illustrates gas heat operation. If the unit is less condenser heat, refer to only the bottom two functions as noted in chart. The ambient limits and safety controls must close for unit to function.

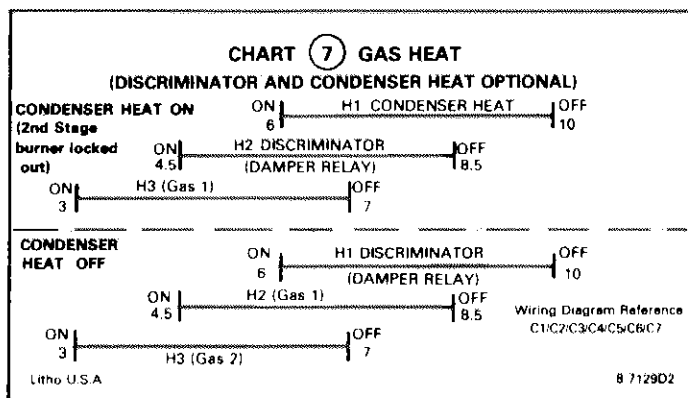

Condenser Heat On

- 1 - Compressor 1 operation energizes K30 which locks out second stage of gas heat and permits condenser heat. At 6 volts "H1" closes to activate condenser heat. No. 1 outdoor fan also stops. "H1" opens at 10 volts to shut off condenser heat.
- 2 - At 4.5 volts "H2" switch closes to energize discriminator (damper relay) and drive outdoor dampers to minimum position. "H2" opens at 8.5 volts.
- 3 - At 3 volts "H3" switch closes to actuate the first stage of gas heat. "H3" opens at 7 volts to shut off burner.

Condenser Heat Off

- 1 - At 6 volts "H1" closes to energize discriminator (damper relay) and drive outdoor dampers to minimum position. "H1" is used only with condenser heat. "H1" opens at 10 volts.
- 2 - At 4.5 volts "H2" switch closes to actuate the first stage of gas burner. "H2" opens at 8.5 volts.
- 3 - At 3 volts "H3" switch closes to activate the second stage of gas burner. "H3" opens at 7 volts.

IV - SAFETY MONITORING CONTROLS

Although the heating command signal calls for heat, the following controls affect unit operation.

1 - Description of S8 thru S12.

These switches terminate burner operation when temperatures or pressures exceed their set points. Refer to "Component" section on page 20 for a detailed description.

2 - Hot Deck Limit (A7)

The hot deck limit (A7) and corresponding thermistor (RT15) monitor the hot deck temperature to change the heating command signal at temperatures above set point. For example if the "Lo" signal from load analyzer is 2 VDC and asks for full heat, but the hot deck temperature is already at set point, A7 will raise the command signal to lower the heating demand.

The limit is factory set at 90°F; however, the setting can be field changed to either 110°F or 130°F if desired. Refer to Figure 44 to change setting.

A7 and RT15 do not initiate the heating demand. Figure 26 on page 20 identifies A7.

3 - Time Delays

On gas units with R4795D primary control, DL8 delays entire burner operation for 5 seconds to prevent lockout due to thermostat short cycling. DL9 delays start of second stage gas for 5 minutes. Refer to figure 26 on page 20.

V - INITIAL GAS START-UP

A - Leak Checking

Check all piping connections for gas leaks. Use a soap solution or other preferred means. Do not use matches, candles, flame or other sources of ignition to check for gas leaks. Refer to the following procedure to check gas valves:

- 1 - Turn off power to unit so that valve closes and gas pressure is upstream.
- 2 - Close manual shut-off valve.
- 3 - Place a "B" valve (field provided) on downstream side of valve.
- 4 - Connect a hose from "B" valve to a bottle of water.
- 5 - Close manual test valve (C.G.A. units only).
- 6 - Open manual shut-off valve.
- 7 - Open the "B" valve and watch for water bubbles. A maximum of 7 bubbles per minute is allowed, based on 1/4" (6 mm) tubing. If more, replace gas valve.

GAS HEAT OPERATION WITH CONDENSER HEAT ON

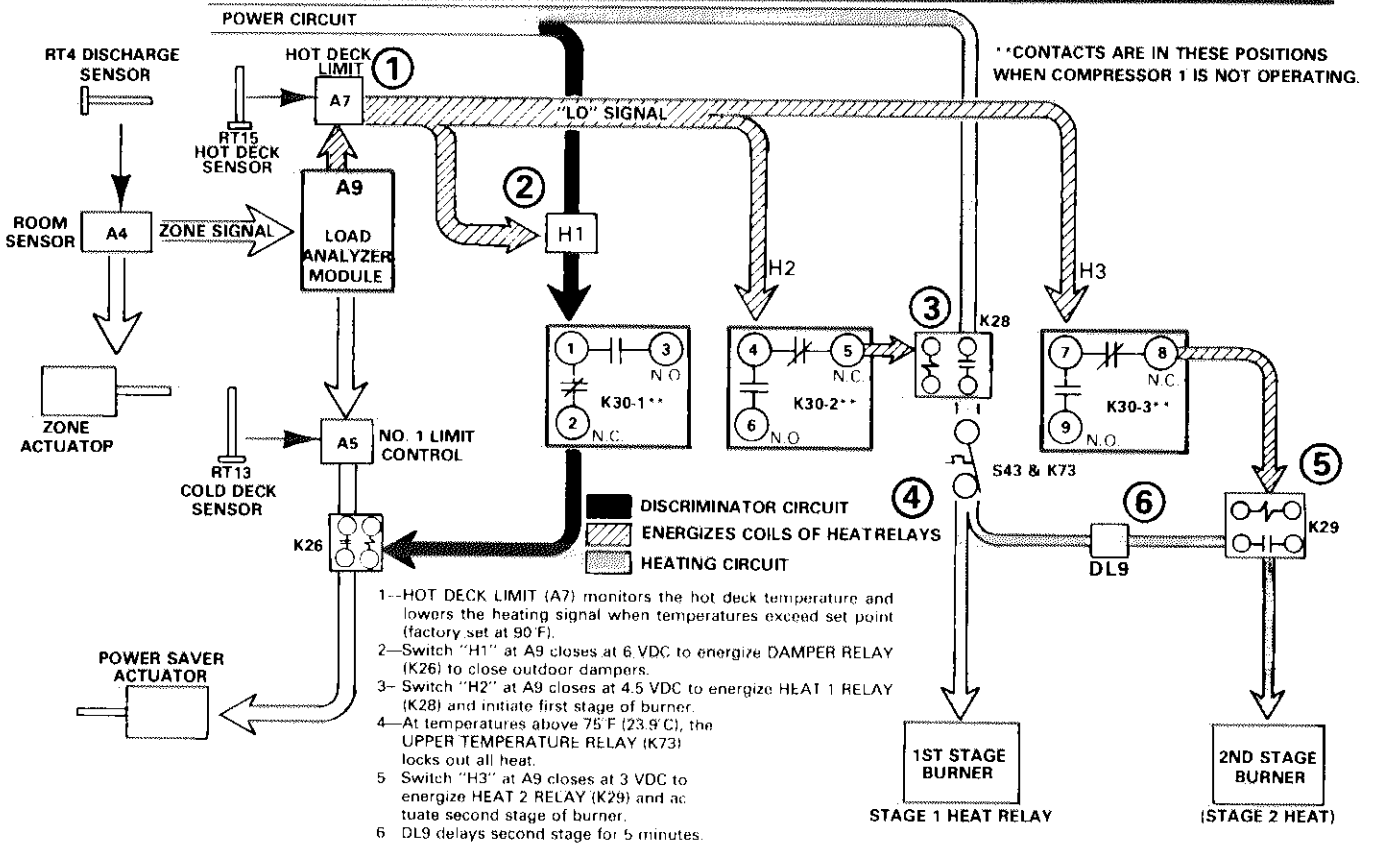
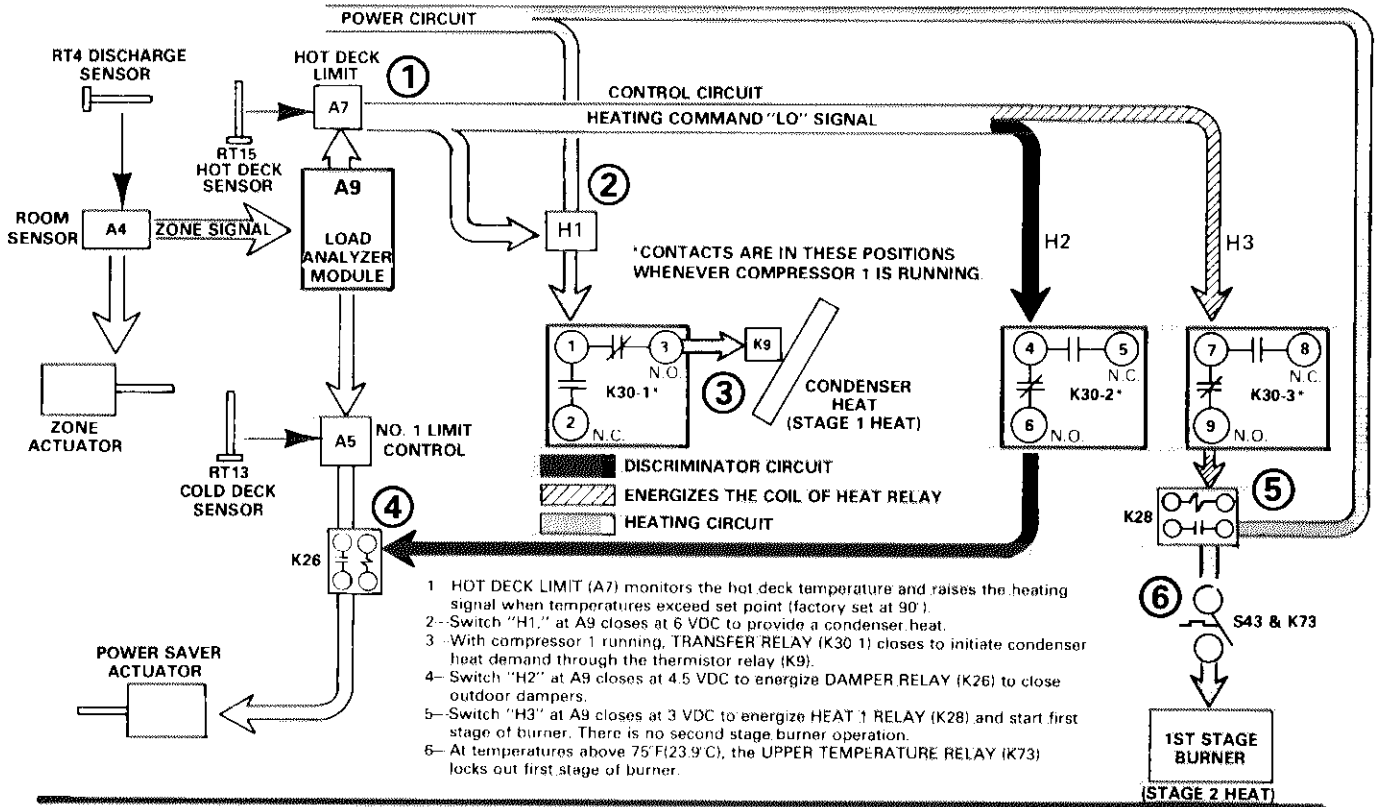

GAS HEAT OPERATION WITH CONDENSER HEAT OFF

FIGURE 43

**TABLE 5
GAS PRESSURE VALUES**

| BURNER | | LINE PRESSURE | | | | +PILOT REGULATOR | | MAIN REGULATOR | | | |
|----------|----------|---------------|---------|---------|---------|------------------|---------|----------------|---------|---------|---------|
| Btuh | Kcal/hr. | Natural | | Propane | | "w.c. | mm w.c. | Natural | | Propane | |
| | | "w.c. | mm w.c. | "w.c. | mm w.c. | | | "w.c. | mm w.c. | "w.c. | mm w.c. |
| 275,000 | 69 300 | 6 | 152 | ---- | ---- | 4 | 101 | 3.5 | 88.9 | ---- | ---- |
| 350,000 | 88 200 | 6 | 152 | 11 | 279 | 4 | 101 | 3.5 | 88.9 | 9 | 228 |
| 500,000 | 126 000 | 6 | 152 | 11 | 279 | 4 | 101 | 3.5 | 88.9 | 9 | 228 |
| *700,000 | 176 400 | 6 | 152 | 11 | 279 | 4 | 101 | 3.5 | 88.9 | 9 | 228 |
| †850,000 | 214 200 | 6 | 152 | 11 | 279 | 4 | 101 | 3.5 | 88.9 | 9 | 228 |

*(2) 350,000 Burners
†(1) 350,000 Burner and (1) 500,000 Burner.
+ Natural Gas Only.

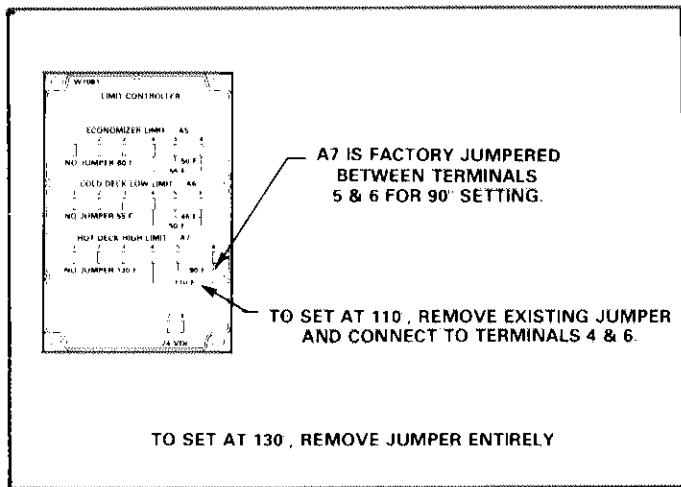

FIGURE 44

8 - Repeat leak check for each valve. If necessary add jumpers at terminal strip above burner to open gas valves upstream of valve being checked.

9 - Remove all jumpers and "B" valves and restore unit to operating condition.

B - Start-Up

- 1 - Close main disconnect switch on unit. Indoor blower and return air blower (if used) should start.
- 2 - Open gas supply line valve(s) to unit. Open burner manual main shut-off valve. Open manual pilot shut-off valve.
- 3 - Perform the heating check-out as instructed in this section. The primary control may lockout several times until the air is purged from gas line.

VI - GAS PRESSURE

- 1 - *Line Pressure* - Take the reading on line side of burner shut-off valve. Refer to Table 5 for pressure. Reading should be taken with all units operating at maximum firing rate. If high gas pressure, over 11" w.c. (279 mm w.c.) is supplied to building, a pounds to inches (kilograms to millimeters) regulator must be used to lower the pressure to the required limits.
- 2 - *Pilot Regulator (natural gas only)* - Refer to Table 5 for setting. Adjust setting with unit firing at maximum rate.
- 3 - *Main Regulator* - Refer to Figure 40 for location to take reading and Table 5 for setting. Take reading and make adjustments with unit operating at maximum firing range.

VII - PRESSURE SWITCH SETTINGS (F.I.A./F.M. UNITS ONLY)

F.I.A./F.M. approved units are equipped with a high pressure and a low pressure switch. Refer to Figure 40 of this instruction for the location of switches and to Table 6 for their set point.

TABLE 6

| GAS | PRESSURE SWITCH SETTINGS | | | |
|---------|--------------------------|---------|----------|---------|
| | High | | Low | |
| | in. w.c. | mm w.c. | in. w.c. | mm w.c. |
| Natural | 7 | 177 | 3 | 76 |
| Propane | 12 | 304 | 8 | 203 |

VIII - MICRO-AMP READINGS

Check with micro-ammeter through jack provided on primary control (1 each burner). Refer to Table 7 for proper micro-amp reading.

**TABLE 7
MICRO AMP READINGS**

| Burner | | Pilot | Low Fire | | High Fire | |
|----------|---------|-------|----------|-------|-----------|-------|
| Btu | Kcal/hr | | Nat. | Prop. | Nat. | Prop. |
| 275,000 | 69 300 | 2-3 | ---- | ---- | 3-5 | ---- |
| 350,000 | 88 200 | 2-3 | 2-4 | ---- | 3-5 | 3-5 |
| 500,000 | 126 000 | 2-3 | 3-5 | 3-5 | 3-5 | 3-5 |
| *700,000 | 176 400 | 2-3 | 3-5 | 3-5 | 3-5 | 3-5 |
| †850,000 | 214 200 | 2-3 | 3-5 | 3-5 | 3-5 | 3-5 |

*(2) 350,000 Burners.
†(1) 350,000 Burner and (1) 500,000 Burner.

NOTE - For pilot readings, close burner manifold shut-off valve to hold burner in pilot position.

IX - MINIMUM BLOWER HORSEPOWER REQUIREMENTS

Table 8 lists the minimum horsepower requirements per size burner as required by A.G.A.

**TABLE 8
A.G.A. MINIMUM H.P. ON BLOWERS**

| Gas Input (Btuh) | Minimum Supply Air Blower Motor Required | *Minimum Return Air Blower Motor Required |
|------------------|------------------------------------------|-------------------------------------------|
| 350,000 | 5 hp | 1-1/2 hp |
| 500,000 | 5 hp | 1-1/2 hp |
| 700,000 | 7-1/2 hp | 3 hp |
| 850,000 | 10 hp | 3 hp |

*Return air blower is optional and not required in all applications.

X - HEATING CHECK-OUT USING LOAD SIMULATOR

Connect the load simulator as shown in Figure 45 on page 47. The following procedure will check the heating logic relays at the load analyzer module.

- 1 - If the unit is equipped with condenser heat and discriminator, install a jumper between the 24 VDC (+) terminal and any zone terminal to provide a cooling demand.
- 2 - Connect DC voltmeter negative lead to terminal #7 of hot deck limit (A7) and positive lead to terminal #1 of hot deck limit (A7).
- 3 - Connect test lights to the heating logic relays and No. 8 terminal of TB-C terminal strip. For ease in installing test lights, we recommend making a harness as shown.
- 4 - Refer to function chart. Slowly rotate load simulator while observing voltmeter. As the load simulator lowers the heating command input voltage, the heating logic relays will respond according to the function chart sequence of operation. Observe test lights to verify switching action and then check mechanical operation of unit.
- 5 - Slowly reverse rotation of load simulator until output voltage reaches 12. The heating logic relays will open according to the chart.
- 6 - Remove jumpers (if used). Disconnect load simulator, test lights and DC voltmeter from the load analyzer module. Reconnect the negative and positive wires to the correct 24 VDC terminals.

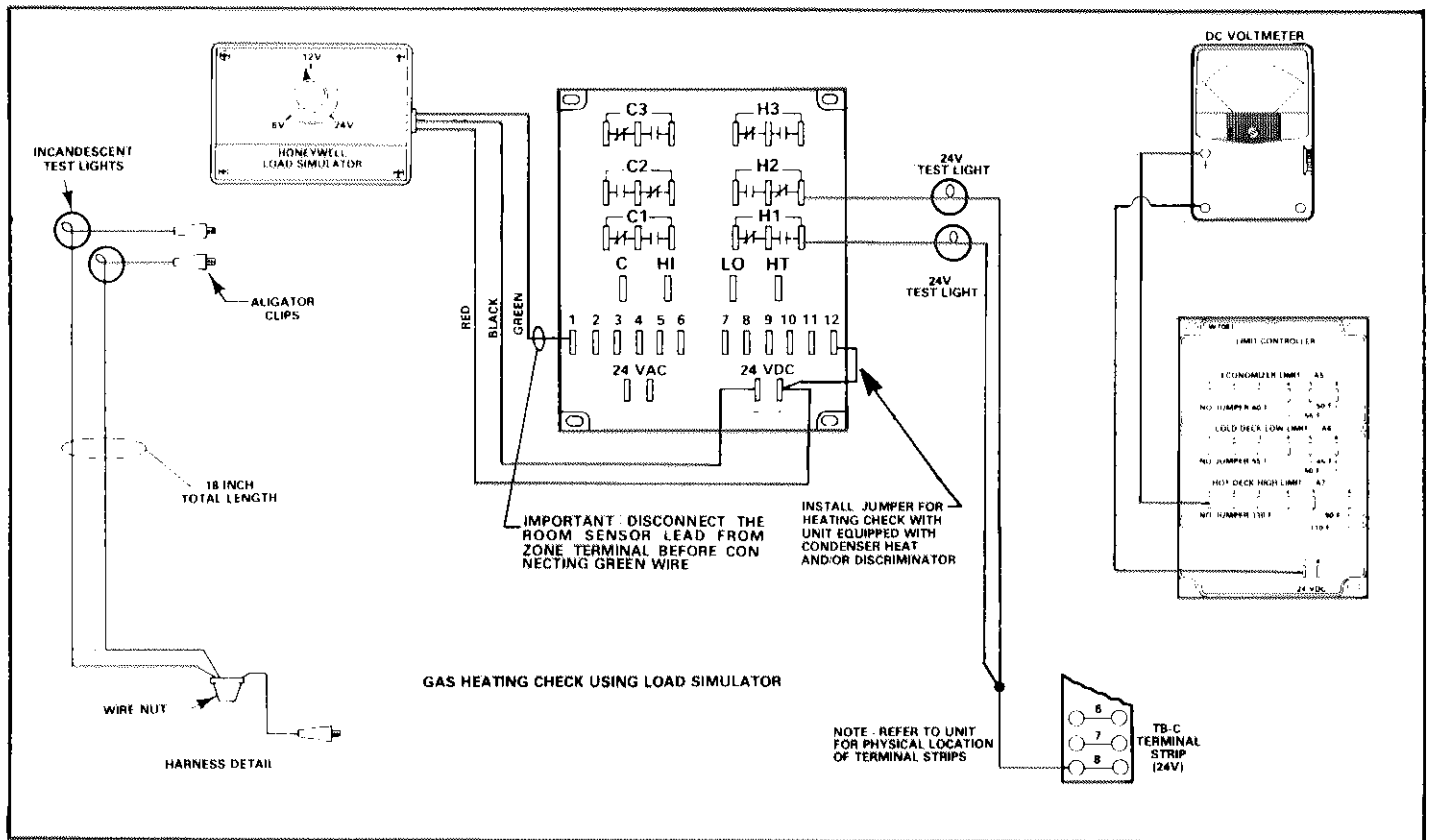
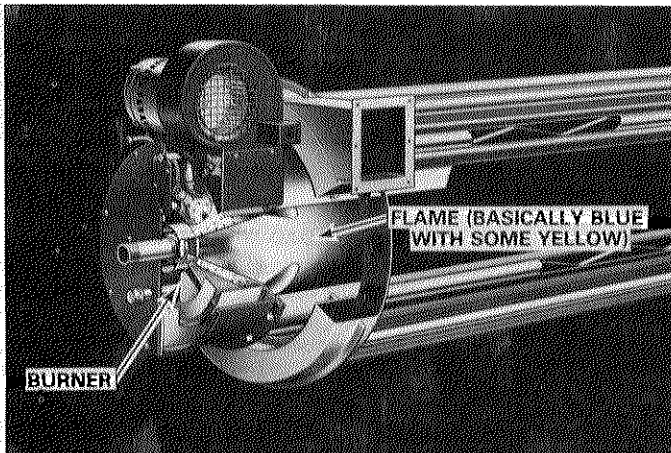

FIGURE 45

XI - BURNER FLAME

Check burner flame. Flame should be basically blue with some yellow. Refer to illustration.



XII - CLEANING

To clean heat exchange, refer to the following procedure.

- 1 - Turn off both electrical and gas power supplies to furnace. (Refer to Figure 39 for parts identification for disassembly and reassembly procedures.)
 - 2 - Remove burner access panel from back of unit.
 - 3 - Remove rear breaching gasket.
 - 4 - Remove flue baffles.
 - 5 - Using a long slender brush, clean flue passages.
 - 6 - Vacuum loose soot particles from each flue passage.
- NOTE - If rear breaching is removed, gasket must be replaced.*

XIII - POWER CONSUMPTION

NOTE - Normal power consumption of the ignition device is 1.7 wattshour in the standby mode.

XIV - EFFICIENCY RATING

The efficiency rating of the furnace is a product thermal efficiency rating determined under continuous operating conditions independent of any installed system.

REPAIR PARTS LISTING FOR GAS HEATING SECTION

The following parts are available through certified Lennox dealers. When ordering parts include the complete unit model number listed on the A.G.A. rating plate. Example — DMS4-275-350.

| KEY NO. | PART NAME | KEY NO. | PART NAME |
|---------|-------------------------------------|---------|--------------------|
| 1 | Heat Exchanger | 31 | Limit Control |
| | Flue Baffle | 32 | Fan Control |
| | Rear Breech Gasket | 41 | Gas Valve |
| | Rear Breeching | 42 | Manual Gas Valve |
| 6 | Vestibule Panel #1 | 43 | Gas Valve |
| 7 | Vestibule Panel #2 | | Operator |
| | Comb. Chamber Gasket | | Body Valve |
| | Flue Extension Gasket | 44 | Gas Valve |
| | Extension #1 & #2 (Aluminized) Flue | 45 | Gas Valve |
| | Extension #1 & #2 (Vit.) Flue | 46 | Gas Valve |
| | Vent Cap Pkg. | 47 | Manual Gas Valve |
| | Outer Flue Liner | 48 | Manual Gas Valve |
| | Inspection Plug | 49 | Manual Gas Valve |
| 9 | Nipple Orifice | 50 | Manual Gas Valve |
| 10 | Nipple Orifice | 51 | Pressure Regulator |
| 12 | Limit Control Bracket | 53 | Pressure Regulator |
| 13 | Limit Control Bracket | | Pressure Switch |
| 15 | Blower Assy. Comb. Air | 54 | Pressure Regulator |
| 16 | Burner | | |
| 30 | Limit Control | | |

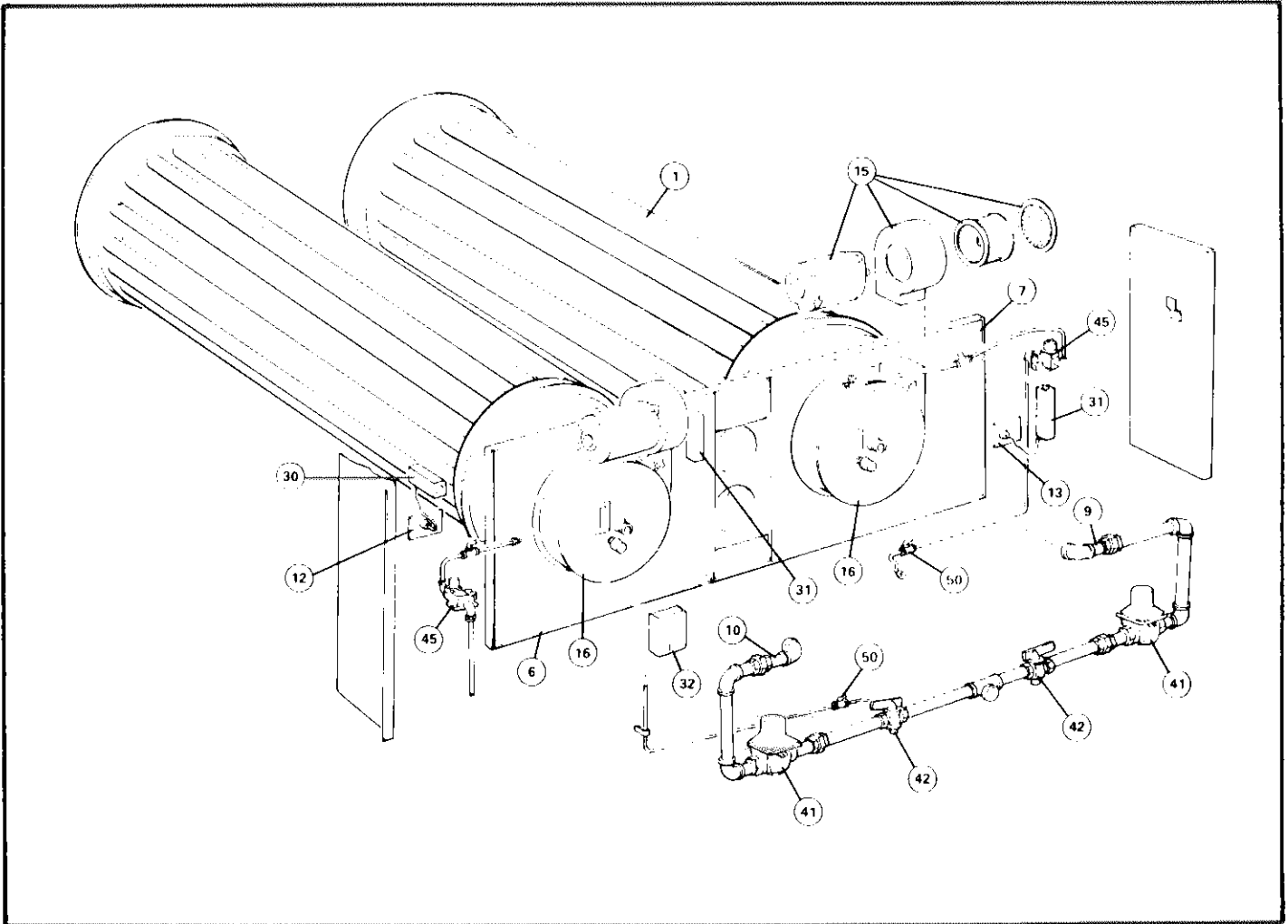

HEATING

ELECTRIC HEAT

I - ELECTRIC HEAT SECTION

Figure 46 identifies the electric heat section for -185, -205, -275, -300, -360 units and Figure 47 identifies the -415, -600.

II - HEATING CAPACITY

Table 10 lists the number of elements available and gives the corresponding Btuh value based on the voltage.

In addition to the A9 load analyzer module, an A10 electric heat sequencer is used to step the elements. The A10 responds to the same heating command signal as the A10; so consequently, the heating logic relays function the same. Table 9 lists the number of elements controlled by each switch of the A10.

NOTE - A 7.5 KW load (1/2 of element #1) is connected to sequencer switches H1 and H2.

TABLE 9

| TOTAL NUMBER OF ELEMENTS | ELEMENTS PER SEQUENCER SWITCH | | | | |
|--------------------------|-------------------------------|-----|----|----|-----|
| | H1 | H2 | H3 | H4 | H5 |
| 3 | 1/2 | 1/2 | 1 | 1 | --- |
| 4 | 1/2 | 1/2 | 1 | 2 | --- |
| 5 | 1/2 | 1/2 | 1 | 2 | 1 |
| 6 | 1/2 | 1/2 | 1 | 2 | 2 |
| 7 | 1/2 | 1/2 | 1 | 2 | 3 |
| 8 | 1/2 | 1/2 | 1 | 2 | 4 |
| 9 | 1/2 | 1/2 | 1 | 2 | 5 |
| 10 | 1/2 | 1/2 | 1 | 3 | 5 |

-185, -205, -275-300 AND -360 SERIES ELECTRICAL CONTROL BOX

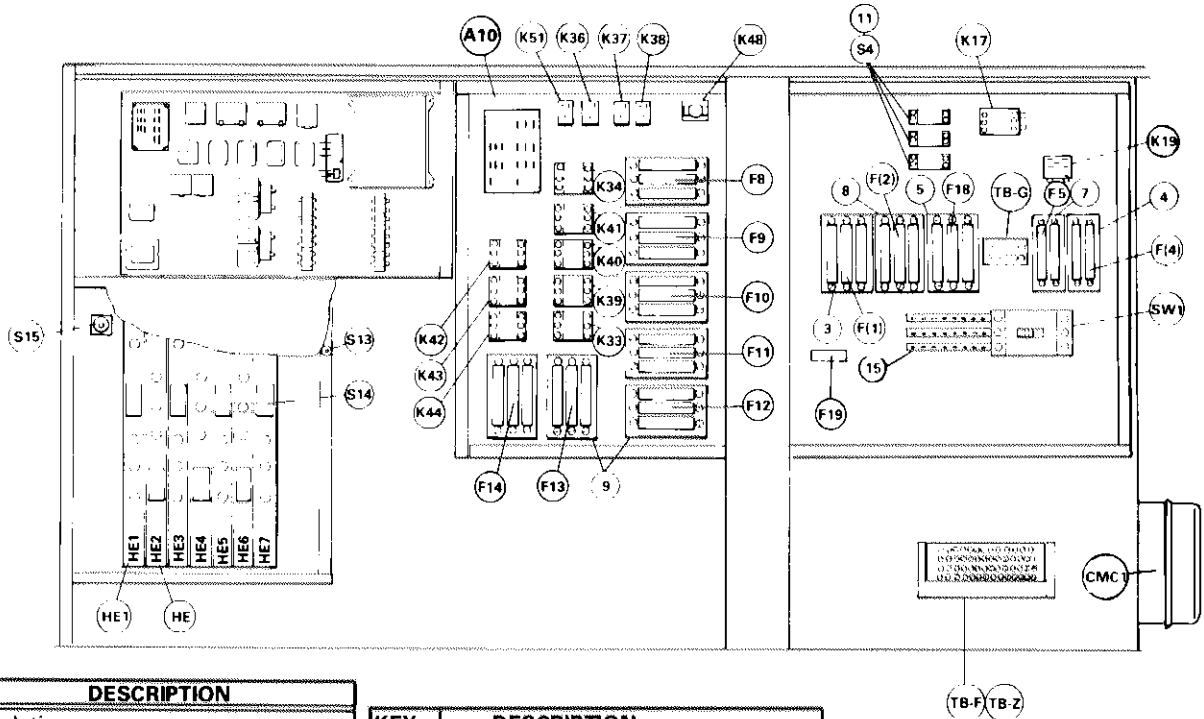

| KEY | DESCRIPTION |
|--------|--------------------------------------------------|
| CMC1 | clock timer |
| DL7 | relay - blower dly (smoke detection) (DMS4 Only) |
| A10 | module-elec. ht. load sequen. (DMS4) |
| F (1) | fuse - compressor 1 |
| F (2) | fuse - compressor 2 |
| F (4) | fuse - compressor control |
| F (5) | fuse - transformer |
| F (8) | fuse - element #1 |
| F (9) | fuse - element #2 |
| F (10) | fuse - element #3 |
| F (11) | fuse - element #4 |
| F (12) | fuse - element #5 |
| F (13) | fuse - element #6 |
| F (14) | fuse - element #7 |
| F18 | fuse - inverter (RVZ1 Only) |
| F19 | fuse - 2 KVA transformer secondary (RVZ1 Only) |

| KEY | DESCRIPTION |
|-----|-------------------------------------|
| HE | element - elec. heat |
| HE1 | element - elec. heat (stage 1 only) |
| K17 | contactor - R.A. blower |
| K19 | relay - shutdown (smoke detector) |
| K33 | contactor - element 1 (stage 1) |
| K34 | contactor - element 1 (stage 2) |
| K36 | relay - discrim. H1 |
| K37 | relay - discrim. H2 |
| K38 | relay - discrim. H5 |
| K39 | contactor - element 2 |
| K40 | contactor - element 3 |
| K41 | contactor - element 4 |
| K42 | contactor - element 5 |
| K43 | contactor - element 6 |
| K44 | contactor - element 7 |
| K48 | relay - element 7 delay |
| K51 | relay - discrim. latch |

| KEY | DESCRIPTION |
|------|--------------------------------------|
| S4 | relay - overload main blower |
| S13 | switch - door interlock |
| S14 | limit safety |
| S15 | limit - hi |
| SW1 | switch - disconnect |
| TB-F | block - terminal (F) (readout) |
| TB-G | block-terminal (G) (RVZ1 Only) |
| TB-Z | block - terminal (Z) room sensor |
| 3 | fuse block - compressor |
| 4 | fuse block - compressor control |
| 5 | fuse block - inverter (RVZ1 Only) |
| 7 | fuse block - transformer (RVZ1 Only) |
| 8 | fuse block - compressor |
| 9 | fuse block - electric heat |
| 11 | heater - overload main blower |
| 15 | buss bar |

FIGURE 46

RVZ1-415 AND -600 SERIES ELECTRICAL CONTROL BOX

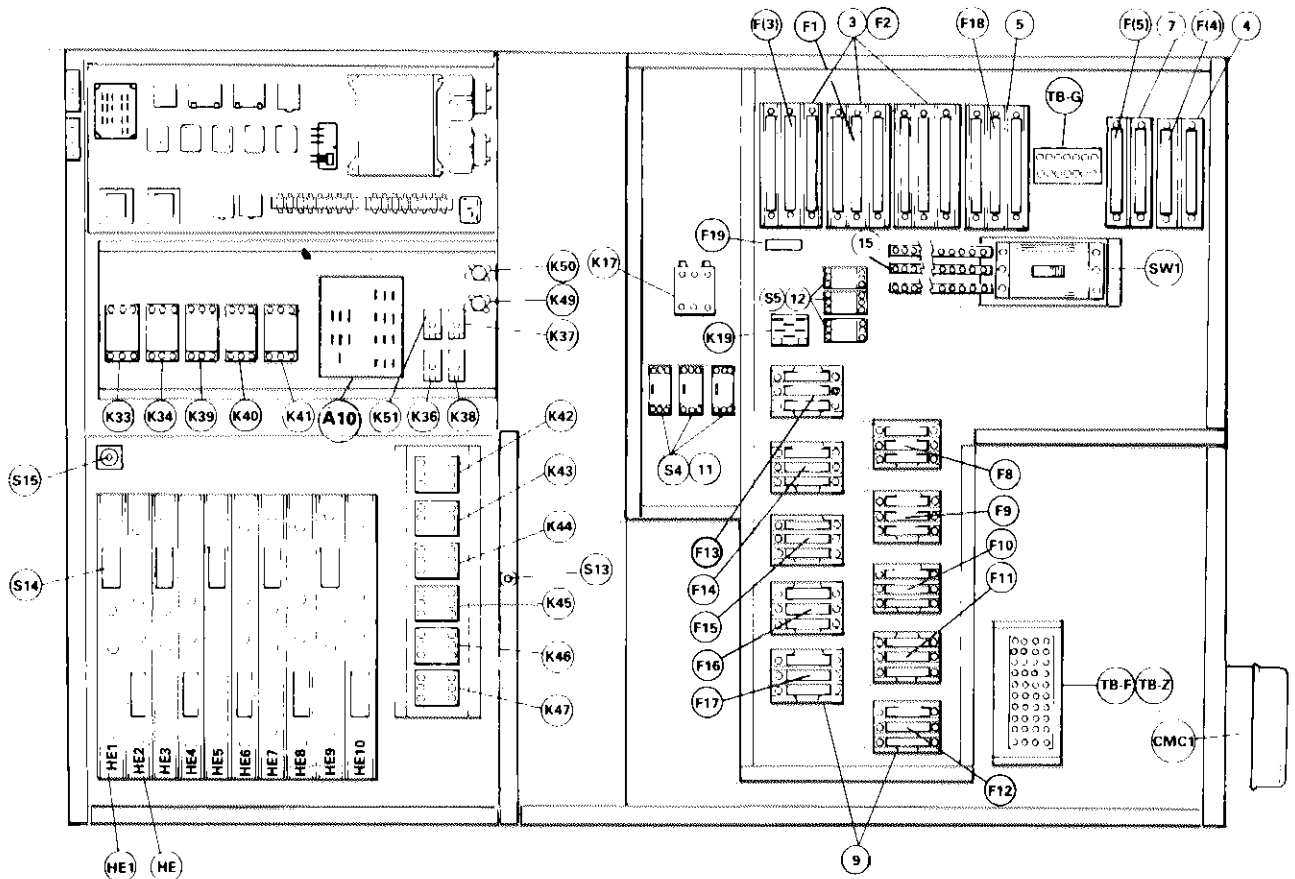

HEATING

| KEY | DESCRIPTION |
|--------|--------------------------------------------------|
| CMC1 | clock timer |
| DL7 | relay - blower dly (smoke detection) (DMS4 Only) |
| A10 | module - elec. ht. load sequencer |
| F (1) | fuse - compressor 1 |
| F (2) | fuse - compressor 2 |
| F (3) | fuse - compressor 3 |
| F (4) | fuse - compressor control |
| F (5) | fuse - transformer |
| F (8) | fuse - element #1 |
| F (9) | fuse - element #2 |
| F (10) | fuse - element #3 |
| F (11) | fuse - element #4 |
| F (12) | fuse - element #5 |
| F (13) | fuse - element #6 |
| F (14) | fuse - element #7 |
| F (15) | fuse - element #8 |
| F (16) | fuse - element #9 |
| F (17) | fuse - element #10 |
| F18 | fuse - inverter (RVZ1 Only) |
| F19 | fuse - 2 KVA transformer secondary (RVZ1 Only) |

| KEY | DESCRIPTION |
|-----|-------------------------------------|
| HE | element - electric heat |
| HE1 | element - elec. heat (stage 1 only) |
| K17 | contactor - R.A. blower |
| K19 | relay - shutdown (smoke detector) |
| K33 | contactor - element 1 (stage 1) |
| K34 | contactor - element 1 (stage 2) |
| K36 | relay - discrim. H1 |
| K37 | relay - discrim. H2 |
| K38 | relay - discrim. H5 |
| K39 | contactor - element 2 |
| K40 | contactor - element 3 |
| K41 | contactor - element 4 |
| K42 | contactor - element 5 |
| K43 | contactor - element 6 |
| K44 | contactor - element 7 |
| K45 | contactor - element 8 |
| K46 | contactor - element 9 |
| K47 | contactor - element 10 |
| K49 | relay - element 10 delay |
| K50 | relay - element 7-8-9 delay |
| K51 | relay - discrim. latch |

| KEY | DESCRIPTION |
|------|--------------------------------------|
| R1 | night blower control RVZ1 Only |
| S4 | relay - overload main blower |
| S5 | relay - overload R.A. blower |
| S13 | switch - door interlock |
| S14 | limit - safety |
| S15 | limit - hi |
| SW1 | switch - disconnect |
| TB-F | block - terminal (F) (readout) |
| TB-G | block-terminal (G) (RVZ1 only) |
| TB-Z | block - terminal (Z) room sensor |
| 3 | fuse block - compressor |
| 4 | fuse block - compressor control |
| 5 | fuse block - inverter (RVZ1 only) |
| 7 | fuse block - transformer (RVZ1 only) |
| 9 | fuse block - electric heat |
| 11 | heater - overload main blower |
| 12 | heater - overload R.A. blower |
| 15 | buss bar |

FIGURE 47

TABLE 10

| ELECTRIC HEAT RATINGS | | | | | |
|-----------------------|-----------------|---------|-----------------|-----------------|-----------------|
| Elements | Volts Input | 208V | 220/240V | 440/480V | 550/600V |
| *3 | KW Input | 33.8 | 37.7/45.0 | 37.7/45.0 | 37.7/45.0 |
| | Btuh Output | 115,300 | 128,000/153,500 | 128,000/153,500 | 128,000/153,500 |
| | Kcal/hr. Output | 29,055 | 32,256/38,682 | 32,256/38,682 | 32,256/38,682 |
| 4 | KW Input | 45.0 | 50.5/60.0 | 50.5/60.0 | 50.5/60.0 |
| | Btuh Output | 153,500 | 169,800/204,600 | 169,800/204,600 | 169,800/204,600 |
| | Kcal/hr. Output | 38,682 | 42,790/51,559 | 42,790/51,559 | 42,790/51,559 |
| 5 | KW Input | 56.3 | 63.0/75.0 | 63.0/75.0 | 63.0/75.0 |
| | Btuh Output | 191,800 | 212,300/255,800 | 212,300/255,800 | 212,300/255,800 |
| | Kcal/hr. Output | 48,334 | 53,499/64,462 | 53,499/64,462 | 53,499/64,462 |
| 6 | KW Input | 67.5 | 75.6/90.0 | 75.6/90.0 | 75.6/90.0 |
| | Btuh Output | 230,200 | 254,700/306,900 | 254,700/306,900 | 254,700/306,900 |
| | Kcal/hr. Output | 58,010 | 64,184/77,339 | 64,184/77,339 | 64,184/77,339 |
| 7 | KW Input | 78.8 | 88.4/105.0 | 88.4/105.0 | 88.4/105.0 |
| | Btuh Output | 268,500 | 297,000/358,000 | 297,000/358,000 | 297,000/358,000 |
| | Kcal/hr. Output | 67,662 | 74,844/90,216 | 74,844/90,216 | 74,844/90,216 |
| †8 | KW Input | 90.0 | 101.0/120.0 | 101.0/120.0 | 101.0/120.0 |
| | Btuh Output | 306,900 | 339,600/409,200 | 339,600/409,200 | 339,600/409,200 |
| | Kcal/hr. Output | 77,338 | 85,579/103,118 | 85,579/103,118 | 85,579/103,118 |
| †9 | KW Input | 101.3 | 113.6/135.0 | 113.6/135.0 | 113.6/135.0 |
| | Btuh Output | 345,300 | 382,100/460,400 | 382,100/460,400 | 382,100/460,400 |
| | Kcal/hr. Output | 87,016 | 96,289/116,021 | 96,289/116,021 | 96,289/116,021 |
| †10 | KW Input | 112.5 | --- | 126.1/150.0 | 126.1/150.0 |
| | Btuh Output | 383,600 | --- | 424,500/511,500 | 424,500/511,500 |
| | Kcal/hr. Output | 96,667 | --- | 106,974/128,898 | 106,974/128,898 |

* -185/275/300/360 units only.

† -415/600 units only.

III - FUNCTION CHART

The following chart illustrates electric heat operation. The "H1" switch at the A9 brings on condenser heat (if used) while the "H" switches on A10 control element stepping.

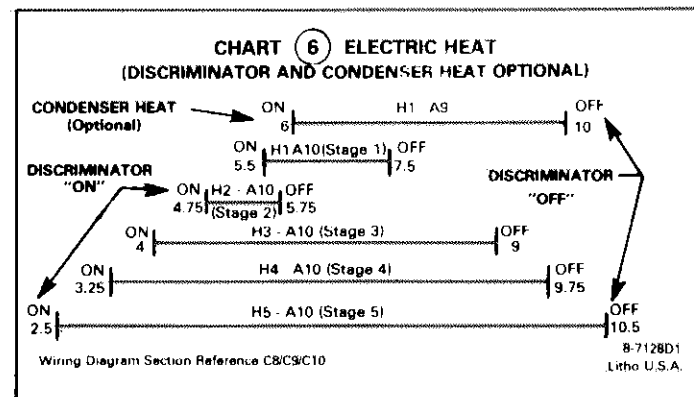

- 1 - If the unit has condenser heat, the "H1" switch on the A9 load analyzer module closes at 6 volts to actuate condenser heat (providing that compressor #1 is operating). The switch opens at 10 volts to shut off condenser heat.
- 2 - At 5.5 volts the "H1" switch on A10 sequencer closes to bring on the first step of electric heat. The switch opens at 7.5 volts to de-energize the first step.
- 3 - The remaining four switches at the A10 sequencer actuate and de-energize their heating elements at the voltages indicated on the function chart.
- 4 - The discriminator (if used) is activated by the closing of "H2" switch at 4.75 volts or "H5" switch at 2.5 volts to drive outdoor air dampers to minimum position. The discriminator remains activated until the "H1" switch at load analyzer module opens at 10 volts or until the "H5" switch at A10 opens at 10.5 volts. For detailed information of electric heat with discriminator, refer to "Sequence of Operation" within this section.

IV - SEQUENCE OF OPERATION

In addition to the A9 and A10 modules a number of relays and limit controls affect electric heat operation. Figure 48 illustrates a control chart for a ten element unit.

A - Condenser Heat (if used)

On the initial heating demand, condenser heat is utilized first before strip heat. After "H1" closes, K9 switches the thermistors into condenser heat. Compressor 1 must run, however, before the heat can be reclaimed.

B - Discriminator (if used)

After "H2" closes, the discriminator option closes the outdoor dampers to terminate power saver. Cooling requirements are satisfied with mechanical cooling and compressor 1 is energized. The following sequence details the discriminator functions with electric heat:

- 1 - As "H2" on A10 closes, discriminator H2 relay (K37) energizes both damper relay (K26) and discriminator latch relay (K51). The outdoor dampers close.
- 2 - The K51 latching circuit then transfers K26 control on to discriminator H1 relay (K36). The outdoor dampers remain closed until "H1" contacts on A9 open.
- 3 - As "H5" on A10 closes, discriminator H5 relay (K38) takes control of K26 and keeps outdoor dampers closed until "H5" opens.

C - Limit Controls and Door Interlock

The door interlock switch (S13) assures that element access panel is in place before electric heat can energize. The hi limit control (S15) stops all electric heat when temperatures exceed the fixed setting. Each element is equipped with a safety limit (S14) which must be manually reset. Figure 49 demonstrates how to reset this back-up limit.

D - Electric Heat Lockout

The electric heat lockout relay (K35) de-energizes all the elements except no. 1 whenever compressor no. 1 is running. This relay thus balances the load between electric elements and compressors to prevent overloading the main switch.

E - Sequence Relay

The sequence relay (K70) is energized by the blower proving switch (S31). It terminates electric heat whenever the supply blower is off. It provides a sequenced start of electric heat.

TYPICAL ELECTRIC HEAT OPERATION (ILLUSTRATING A TEN ELEMENT UNIT WITH) CONDENSER HEAT AND DISCRIMINATOR

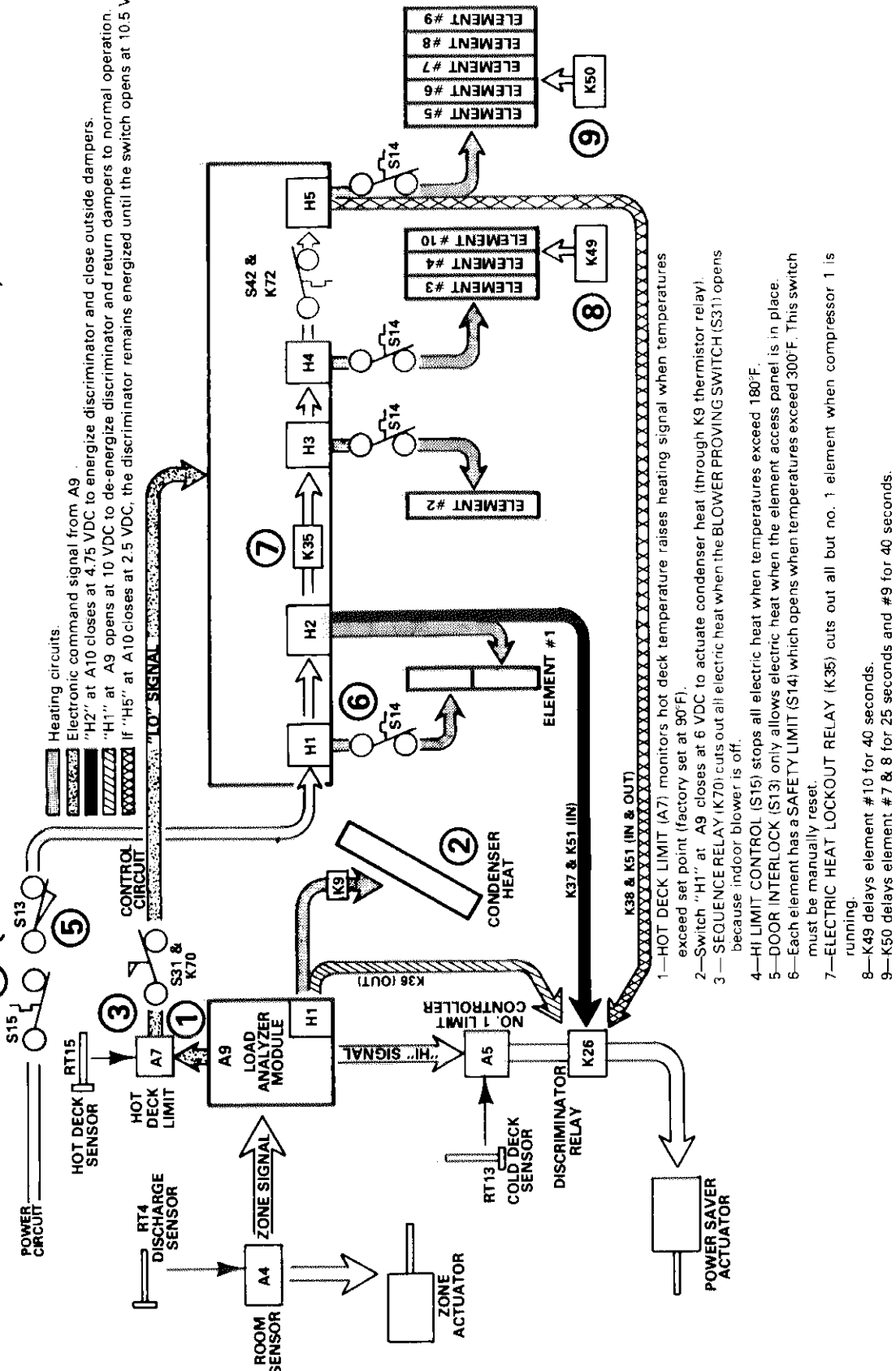

- 1—HOT DECK LIMIT (A7) monitors hot deck temperature raises heating signal when temperatures exceed set point (factory set at 90°F).
- 2—Switch "H1" at A9 closes at 6 VDC to actuate condenser heat (through K9 thermistor relay).
- 3—SEQUENCE RELAY (K70) cuts out all electric heat when the BLOWER PROVING SWITCH (S13) opens because indoor blower is off.
- 4—HI LIMIT CONTROL (S15) stops all electric heat when temperatures exceed 180°F.
- 5—DOOR INTERLOCK (S13) only allows electric heat when the element access panel is in place.
- 6—Each element has a SAFETY LIMIT (S14) which opens when temperatures exceed 300°F. This switch must be manually reset.
- 7—ELECTRIC HEAT LOCKOUT RELAY (K35) cuts out all but no. 1 element when compressor 1 is running.
- 8—K49 delays element #10 for 40 seconds.
- 9—K50 delays element #7 & 8 for 25 seconds and #9 for 40 seconds.

FIGURE 48
Page 52

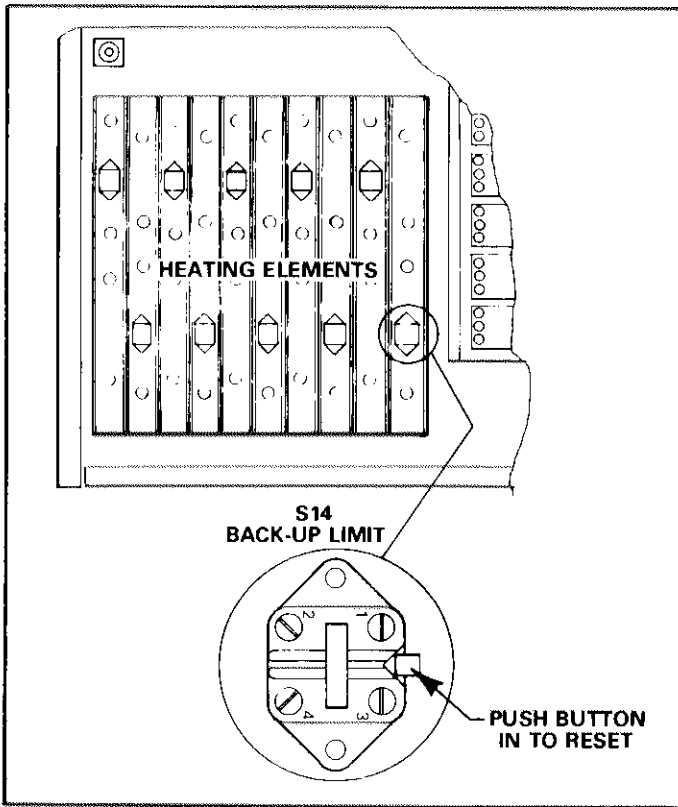

FIGURE 49

C - Hot Deck Limit

The hot deck limit (A7) and corresponding thermistor (RT15) monitor the hot deck temperature to change the heating command signal at temperatures above set point. For example if the "Lo" signal from load analyzer is 2 VDC and asks for full heat, but the hot deck temperature is already at the limit set point, A7 will control the command signal to maintain the hot deck temperature at the set point.

The limit is factory set at 90°F; however, the setting can be field changed to either 110°F or 130°F if desired. Refer to Figure 50 to change setting.

A7 and RT15 do not initiate the heating demand. Figure 26 on page 20 identifies A7.

V - INITIAL ELECTRIC HEAT START-UP

- 1 - Close main disconnect switch on unit. Indoor blower and return air blower (if used) should start.
- 2 - Perform the heating check-out as instructed in this section.
- 3 - Provide a full heating demand to energize all the elements. Using a clamp-on ammeter, check amperage draw of each wiring lead

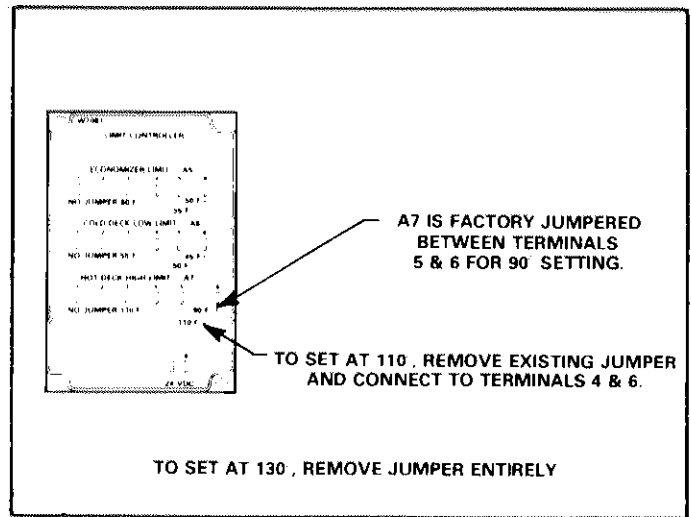

FIGURE 50

from the heater contactors to the heater elements. All leads should measure approximately the same amperage draw. If so, all heater elements are operating satisfactory. If a wiring lead does not register a reading, it indicates that the element is not operating and should be checked.

VI - HEATING CHECK-OUT USING LOAD SIMULATOR

Connect the load simulator as shown in Figure 51 on page 54. The following procedure will check the heating logic relays at the load analyzer and sequence modules.

- 1 - If the unit is equipped with condenser heat and/or discriminator, install a jumper between the 24 VDC (+) terminal and any zone terminal to provide a cooling demand.
- 2 - Connect DC voltmeter negative lead to terminal #7 of hot deck limit (A7) and positive lead to terminal #1 of hot deck limit (A7).
- 3 - Connect test lights to the heating logic relays and No. 6 terminal of TB-D terminal strip. For ease in installing test lights, we recommend making a harness as shown.
- 4 - Refer to function chart. Slowly rotate load simulator while observing voltmeter. As the load simulator lowers the heating command input voltage, the heating logic relays will respond according to the function chart sequence of operation. Observe test lights to verify switching action and then check mechanical operation of unit.
- 5 - Slowly reverse rotation of load simulator until output voltage reaches 12. The heating logic relays will open according to the chart.
- 6 - Remove jumper (if used). Disconnect load simulator, test lights and DC voltmeter from the load analyzer module. Reconnect the negative and positive wires to the correct 24 VDC terminals.

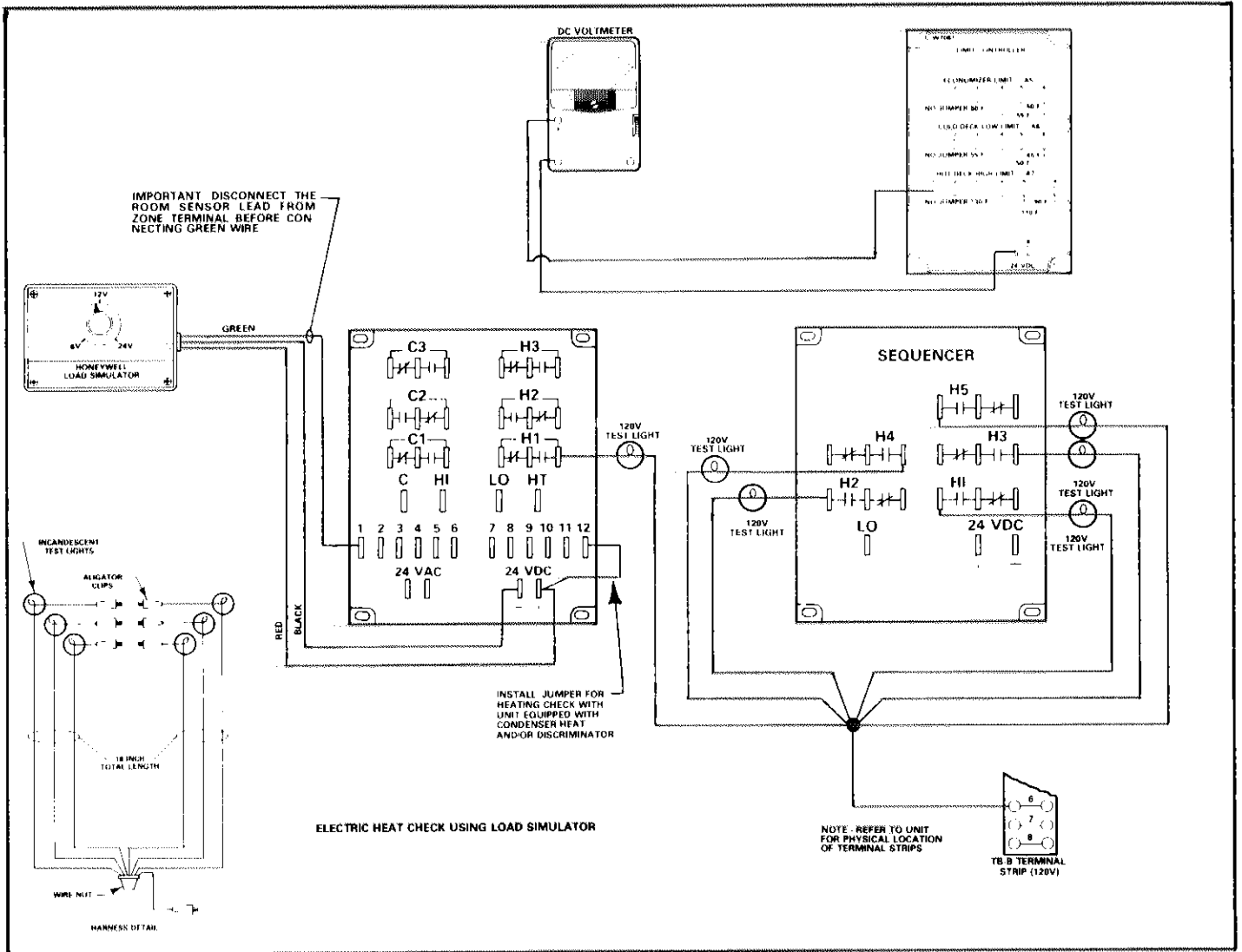

FIGURE 51

HOT WATER AND STEAM HEAT

I - HOT WATER AND STEAM HEAT SECTIONS

Figures 52 and 53 illustrate the hot water and steam sections. The motorized valve is secured to a support bracket for shipping. Remove the two bolts as shown.

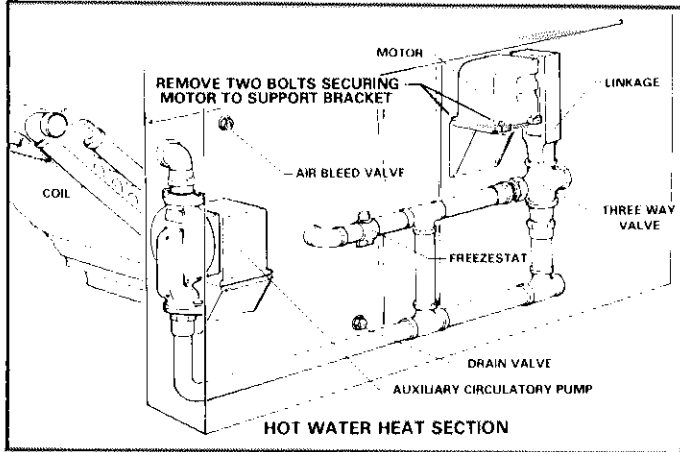

FIGURE 52

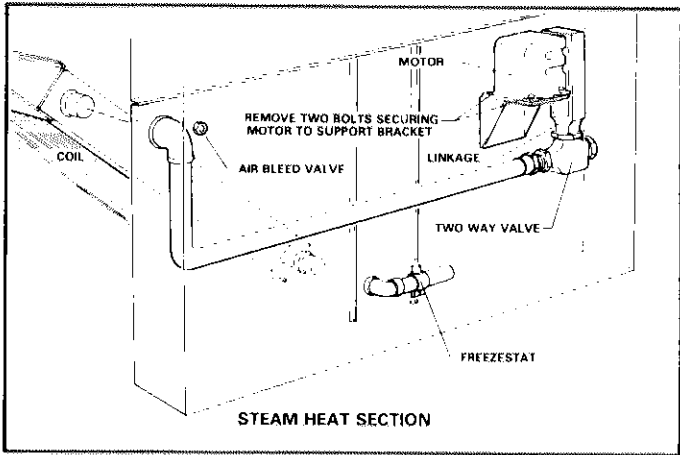
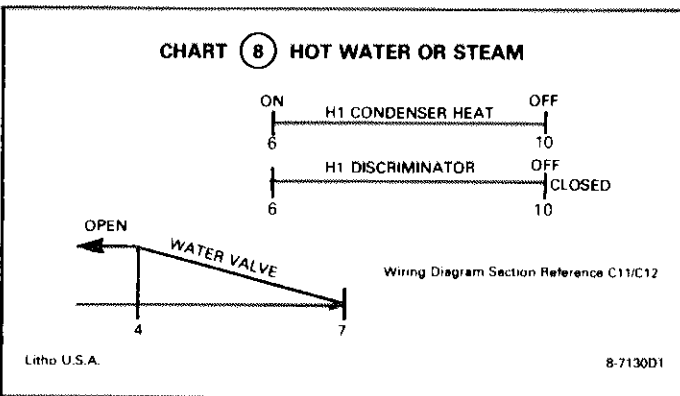

FIGURE 53

II - FUNCTION CHART

The following chart illustrates hot water and steam operation.



- 1 - Switch "H1" on. A9 controls condenser heat and load discriminator operation. The command signal from the "LO" terminal controls valve modulation.
- 2 - At 6 volts "H1" closes to energize condenser heat and load dis-

criminator which drives outdoor air dampers to minimum position. The switch opens at 10 volts.

- 3 - At 7 volts or higher there is no flow through coil.
- 4 - The valve modulates open upon a voltage decrease and is fully open at 4 volts.

III - SEQUENCE OF OPERATION

In addition to the A9 module other controls affect unit operation.

A - Freezestat

The freezestat thermostat (S40) energizes the freezestat relay (K53) at coil manifold temperatures below set point and opens the valve and runs optional pump motor to prevent freezing.

C - Hot Deck Limit

The hot deck limit (A7) and corresponding thermistor (RT15) monitor the hot deck temperature to change the heating command signal at temperatures above set point. For example if the "Lo" signal from load analyzer is 2 VDC and asks for full heat, but the hot deck temperature is already at the limit set point, A7 will control the command signal to maintain the hot deck temperature at the set point.

The limit is factory set at 90°F; however, the setting can be field changed to either 110°F or 130°F if desired. Refer to Figure 54 to change setting.

A7 and RT15 do not initiate the heating demand. Figure 26 on page 20 identifies A7.

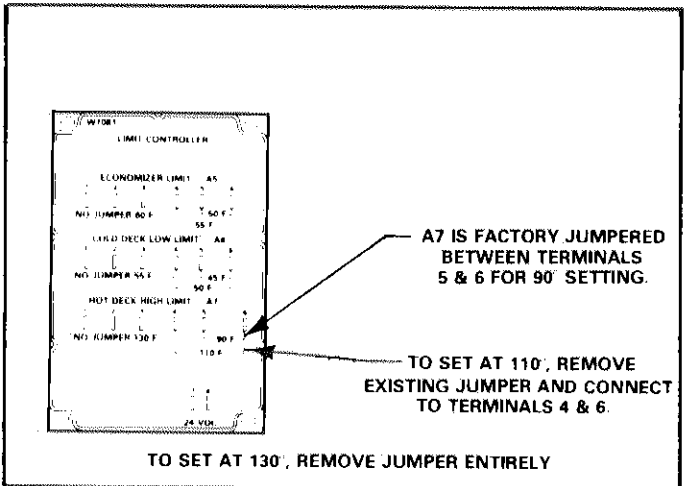

FIGURE 54

IV - CHECKING VALVE

A - Hot Water Coil

- 1 - Close main disconnect switch on unit.
- 2 - Remove wire from terminal #1 on A7 to valve motor. Put jumper across C and F terminals on motor. Motor should rotate clockwise lifting valve stem. Refer to Figure 55.
 - a - At end of stroke, notch in motor shaft should be down, but at an angle 10° to right of vertical.
 - b - The motor should be free to run its complete stroke.
 - c - With the valve in this position, the by-pass line is open and flow to the coil is closed.
- 3 - Remove the jumper installed in step 2. Motor shaft should rotate counterclockwise, lowering valve stem. Refer to Figure 56.
 - a - At end of stroke, notch in motor shaft should be up, but at an angle 10° to right of vertical.
 - b - With the valve in this position, the by-pass line is closed and water will flow through the coil.
- 4 - Remove jumper from terminals C and F on motor. Reconnect wire to terminal #1 on A7.

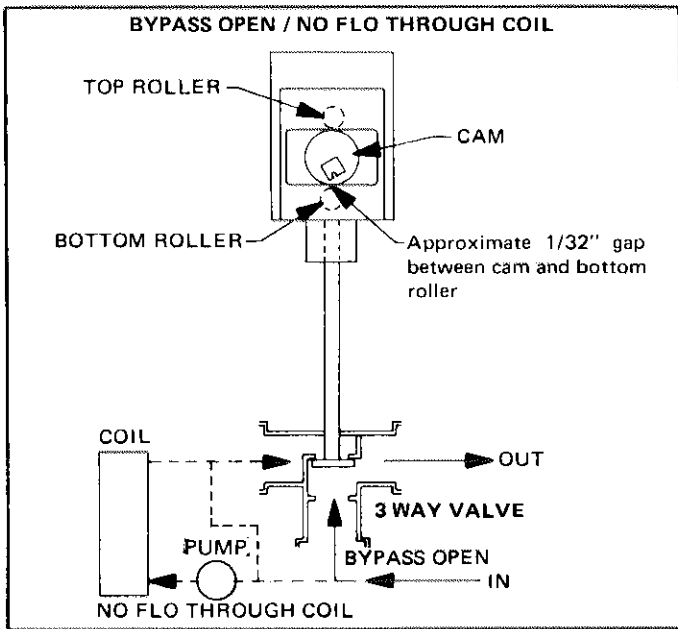

FIGURE 55

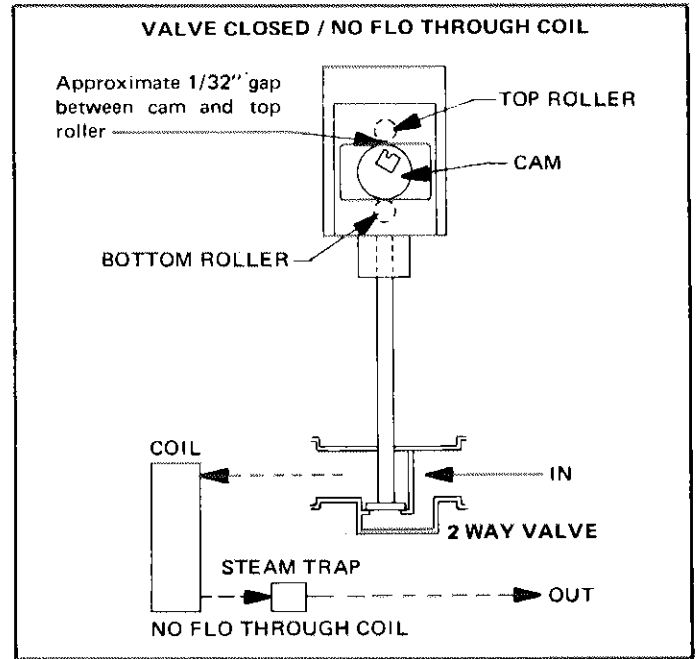

FIGURE 57

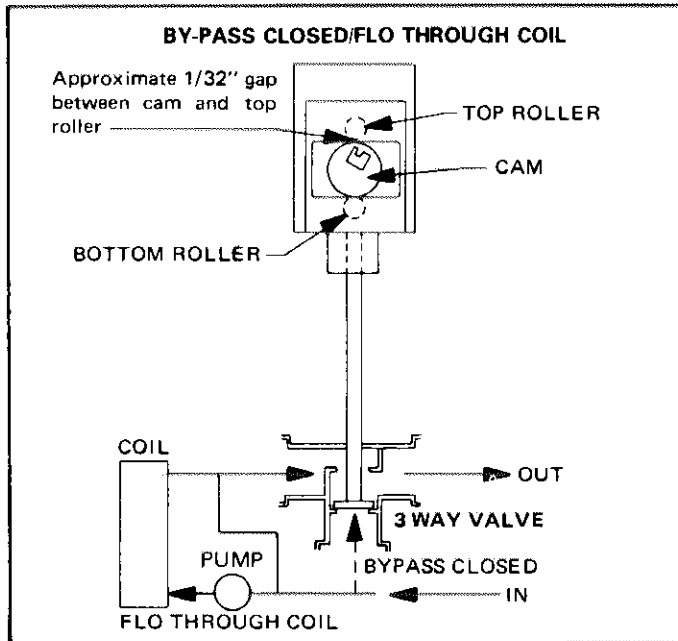

FIGURE 56

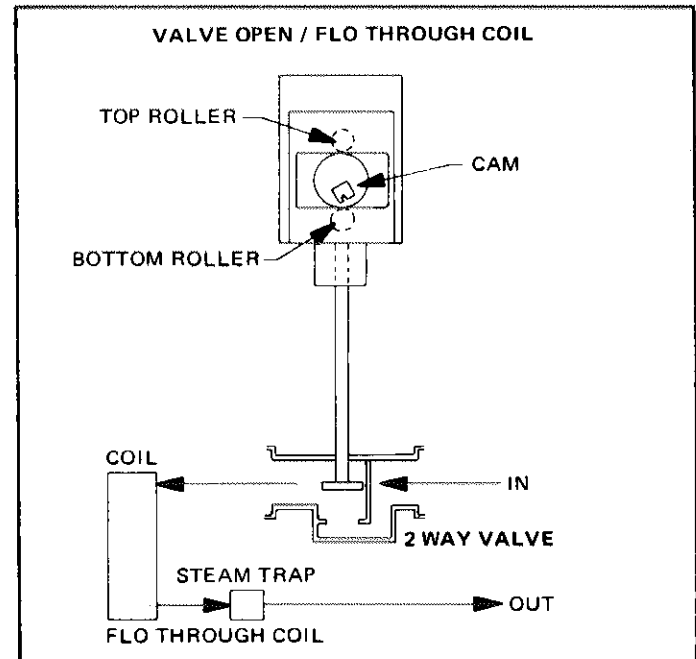

FIGURE 58

B - Steam Coil

- 1 - Close main disconnect switch on unit.
- 2 - Remove wire from terminal #1 on A7 to motor valve. Put jumper across C and F terminals on motor. Motor shaft should rotate counter clockwise, lowering valve stem. Refer to Figure 57.
 - a - At end of stroke, notch in motor shaft should be up, but at an angle 10° to right of vertical.
 - b - With the valve in this position, the valve is closed and flow to the coil is closed.
- 3 - Remove the jumper installed in step 2. Motor should rotate clockwise lifting valve stem. Refer to Figure 58.
 - a - At end of stroke, notch in motor shaft should be down, but at an angle 10° to right of vertical.
 - b - The motor should be free to run its complete stroke.
 - c - With the valve in this position, the valve is open and steam will flow to the coil.
- 4 - Remove jumper from terminals C and F on motor. Reconnect wire to terminal #1 on A7.

V - HEATING CHECK-OUT USING LOAD SIMULATOR

Connect the load simulator as shown in Figure 59 on page 57. The

following procedure will check the heating logic relays and the "LO" signal at the load analyzer module.

- 1 - If the unit is equipped with condenser heat and/or discriminator, install a jumper between the 24 VDC (+) terminal and any zone terminal to provide a cooling demand.
- 2 - Connect DC voltmeter negative lead to terminal #7 of hot deck limit (A7) and positive lead to terminal #1 of hot deck limit (A7).
- 3 - Connect test lights to the heating logic relays and No. 6 terminal of TB-B terminal strip.
- 4 - Refer to basic function chart. Slowly rotate load simulator while observing voltmeter. As the load simulator lowers the heating command input voltage, the heating logic relays will respond according to the function charts sequence of operation.
- 5 - Slowly reverse rotation of load simulator until output voltage reaches 12. "H1" and "H2" will open according to the chart.
- 6 - Remove jumper (if used). Disconnect load simulator, test lights and DC voltmeter from the load analyzer module. Reconnect the negative and positive wires to the correct 24 VDC terminals.

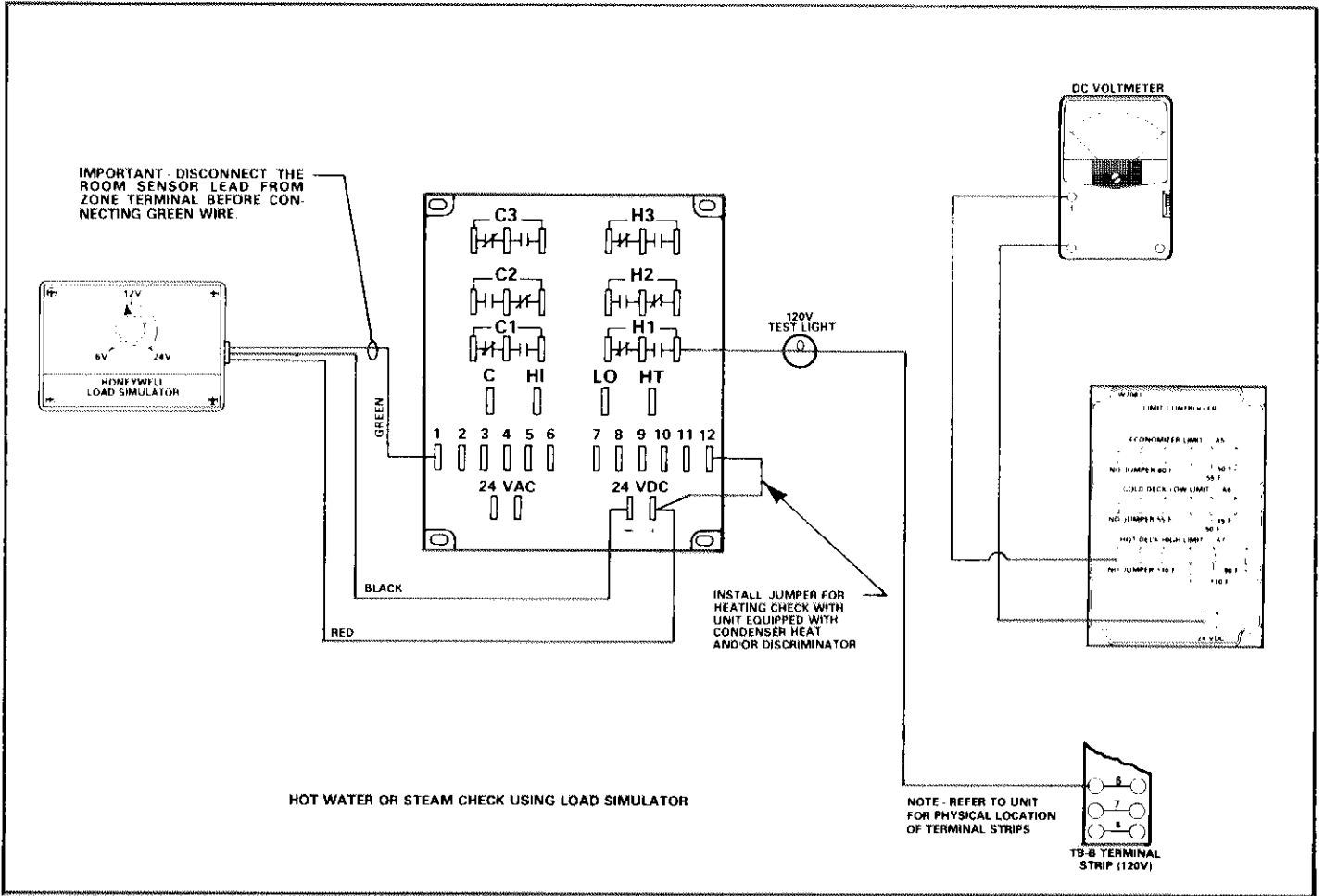

FIGURE 59

POWER SAVER AND DISCRIMINATOR

I - POWER SAVER SECTION

Figure 60 illustrates power saver operation and identifies dampers. A 275 series unit with smoke detection is shown.

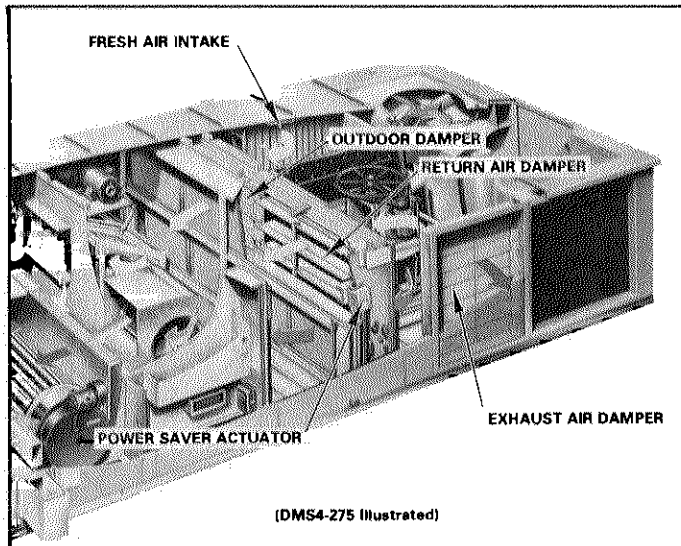

FIGURE 60

II - POWER SAVER OPERATION

A - Power Saver

Units with power saver use outside air for free cooling. During power saver operation, the outdoor air dampers open and the return air dampers close. The return air is exhausted outside. On nite setback the outdoor dampers remain in the fully closed position.

The power saver may be ordered less controls with the dampers linked for manual operation.

B - Power Saver Actuators

1 - Units Less Smoke Detector

One actuator controls outdoor and return air damper operation. These dampers open and close in reverse relationship to each other. Outside air dampers are closed at 14 VDC and open at 17 VDC.

2 - Units With Smoke Detectors

Two actuators control outdoor and return air damper modulation. The actuators work in reverse relationship to each other during normal power saver operation.

The outdoor damper actuator is direct acting. Return air dampers are open at 14 VDC and closed at 17 VDC.

With the presence of smoke, the blowers and dampers are controlled by 1 of 4 options as described in Figure 19 on page 13. For additional information on the smoke detectors, refer to page 39.

C - Discriminator

The discriminator option is used with power saver and condenser heat. It drives the outdoor dampers to minimum position when the number 1 compressor requires less energy to use than what is otherwise needed to heat the hot deck. An "H" switch at the load analyzer module activates the damper relay (K26) to initiate discriminator operation. This will occur on a demand of 15 KW for electric heat, first stage heat demand for gas heat and 30% of the heat demand for hot water and steam heat. Without outside air, cooling needs must be satisfied with DX cooling so the unit can take advantage of condenser heat. Refer to Figure 26 on page 20 to identify K26.

D - Overriding Limit

The no. 1 limit controller (A5) and cold deck power saver thermistor (RT13) modulate the outdoor air dampers to maintain a 50°F (10°C) cold deck temperature. For example if the "HI" signal from load analyzer module is 17 VDC and asks for open outdoor dampers but

the cold deck temperature is already 50°F, A5 will drop the signal to 14 VDC to maintain minimum position.

A5 and RT13 do not initiate the cooling demand. Figures 25 and 26 on page 20 identify the controls.

III - Function Chart

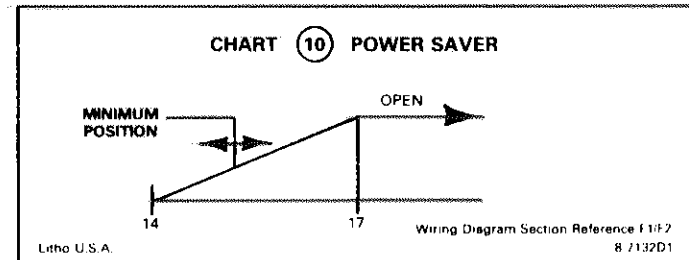

- 1 - The command signal from the "HI" terminal controls actuator(s) operation and subsequent damper modulation. The reading is taken at A5 to reflect cold deck effects on the signal.
- 2 - At 14 VDC the outdoor dampers are closed. Minimum position is approximately 15 VDC.
- 3 - The outdoor dampers modulate open with a voltage increase and are fully open at 17 VDC.

IV - POWER SAVER CONTROLS

Once the command signal initiates a cooling demand, several controls affect power saver operation.

1 - Enthalpy Control

The enthalpy control (S18) senses both temperature and humidity or heat content of the outside air. When the heat content rises above the control set point, the outside dampers close to minimum position. Refer to Figure 28 on page 22 for location.

2 - Morning Warm-up Control (S16)

The morning warm-up control holds outside dampers at closed position until the return air temperature has risen above 70°F (21,1°C). Refer to Figure 28 on page 22 for location.

3 - Power Saver Delay

The power saver includes a delay circuit (K75, K76 & DL10) which holds the outdoor dampers closed for a period of 3 minutes after compressor 1 starts. This assures a load on compressor 1 and permits the cooling circuit to stabilize before the outdoor dampers are permitted to open. Refer to Figure 26 on page 20 for locations.

V - ADJUSTMENTS

A - Linkage Adjustment Without Smoke Detector

- 1 - Remove the lead from terminal TR at outdoor actuator to drive outdoor dampers closed and return air dampers open. Adjust each individual damper blade separately. Refer to Figure 61 for -185, 205, 300 & 360 units or Figure 62 for -415 & 600 units.
- 2 - Reconnect the lead to terminal. Connect leads from 24 VDC terminals at A9 load analyzer to outdoor actuator as dictated in Figure 63. Outdoor dampers will open and return dampers will close. Adjust each individual damper blade separately.

B - Linkage Adjustment With Smoke Detector

- 1 - Disconnect the lead from terminal TR at outdoor actuator to drive outdoor dampers closed. Adjust each individual damper blade separately.
- 2 - Disconnect the lead from terminal at return air actuator to drive return air dampers closed. Adjust each individual damper blade separately.
- 3 - Reconnect leads at both actuators.

COOLING

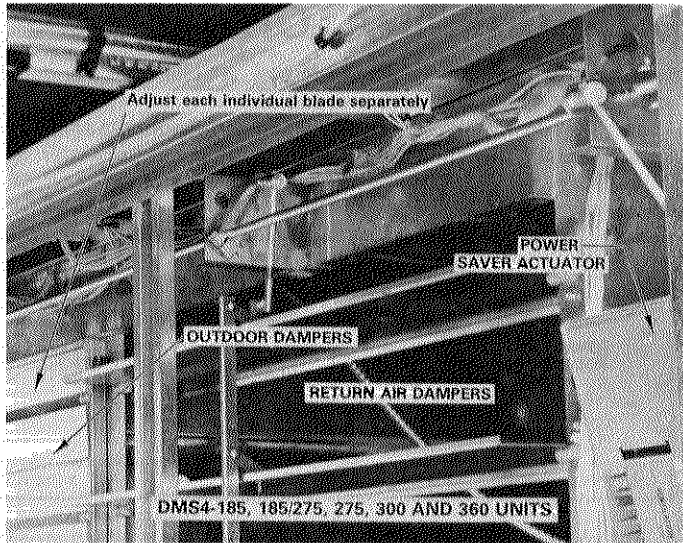

FIGURE 61

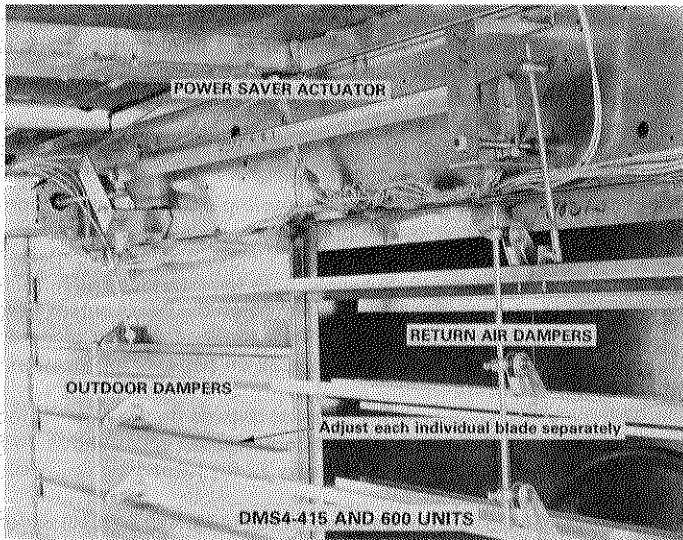

FIGURE 62

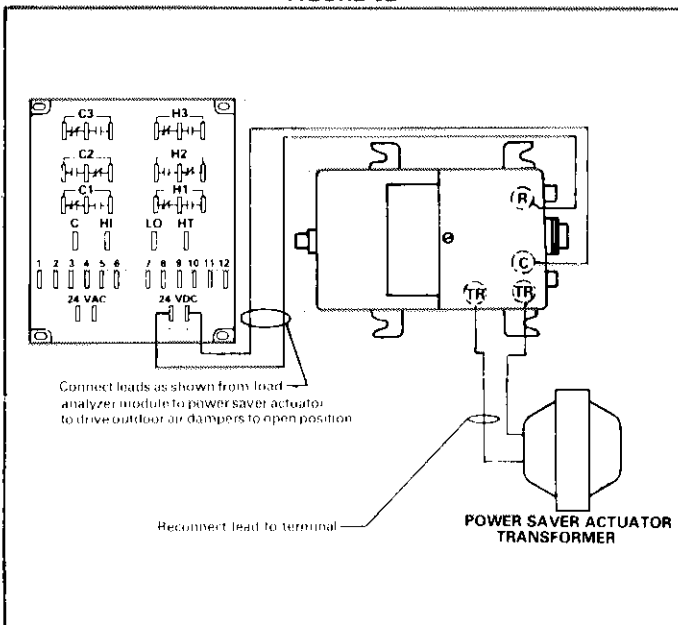
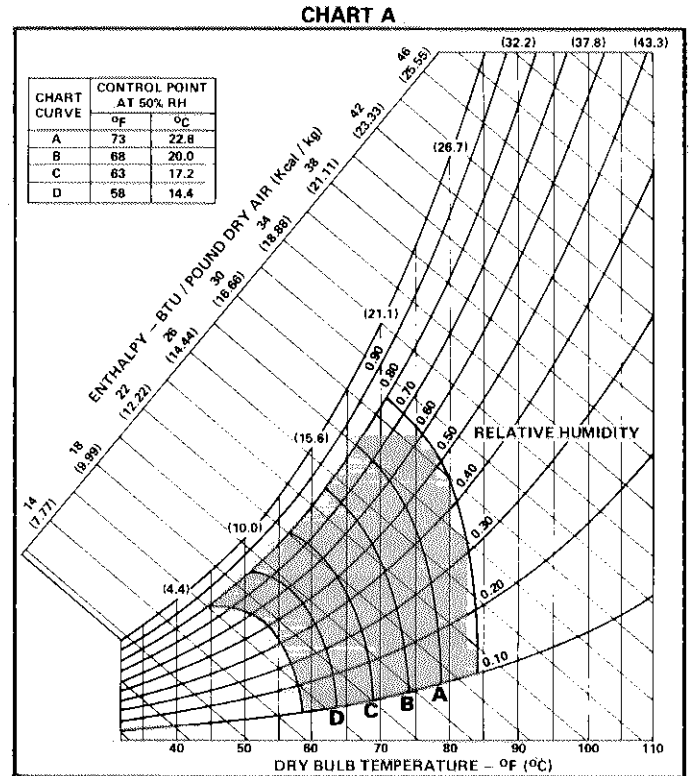

FIGURE 63

C - Enthalpy Control

The recommended set point is "A". If power saver is allowing air which is too warm or too humid to enter system, control may be changed to a lower set point. Refer to Chart A.



D - Minimum Positioner

Adjust minimum positioner with outside dampers at minimum position. Turn setting on enthalpy control to "D". Pull lead of terminal C and adjust minimum positioner control starting from damper closed position until desired minimum position is obtained. Reconnect lead. Rotate screw clockwise to open dampers or counter clockwise to closed dampers. Refer to Figure 64 for actuator. See Chart B for percentage of fresh air versus dimensional opening of blade at system static pressure.

IMPORTANT - After adjustment is completed, return enthalpy control to its normal setting.

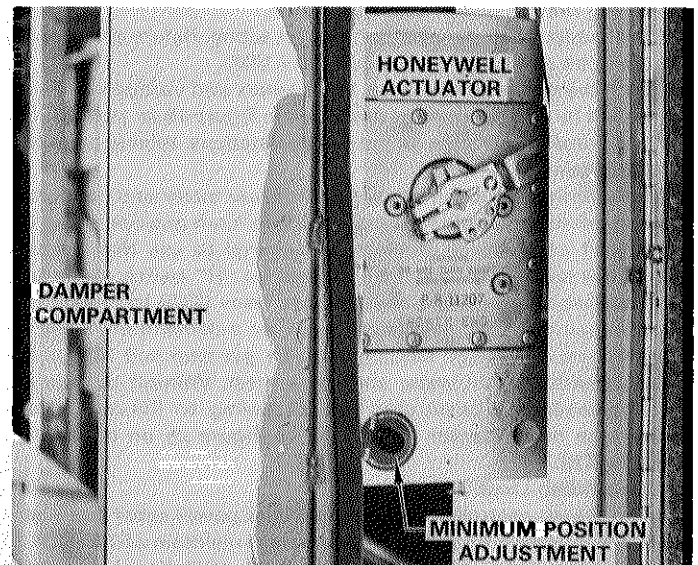
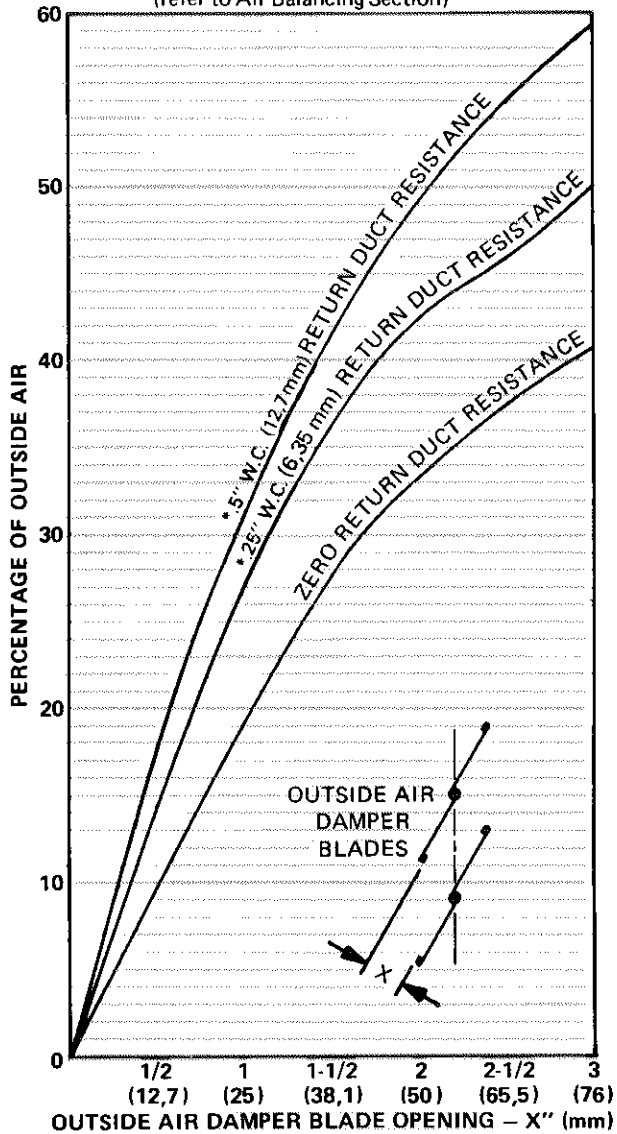

FIGURE 64

CHART B

*Excess of return duct resistance over return air blower capacity (refer to Air Balancing Section)



VI - POWER SAVER CHECK-OUT USING LOAD SIMULATOR

Connect the load simulator as shown in Figure 65. Do not impose a simultaneous heating demand as the following checks are made.

- 1 - Connect DC voltmeter negative lead to 24 VDC (-) terminal and positive lead to terminal #1 on A5 limit controller to obtain cooling command signal.
- 2 - Refer to function chart. As the simulator raises the cooling command input voltage, the power saver actuator(s) will modulate according to the function chart.
- 3 - Slowly reverse the rotation of load simulator until output voltage recedes to 12 VDC. The power saver actuator(s) will close according to the chart.
- 4 - Disconnect load simulator and DC voltmeter. Reconnect the (+) wire which runs from terminal strip TB-Z to 24 VDC terminal at A9 module.

IMPORTANT - Cold deck thermistor (RT13) must be sensing 50°F or above for this check to function. If RT13 is sensing temperatures below 50°F, the limit controller (A5) will hold outdoor dampers at minimum position.

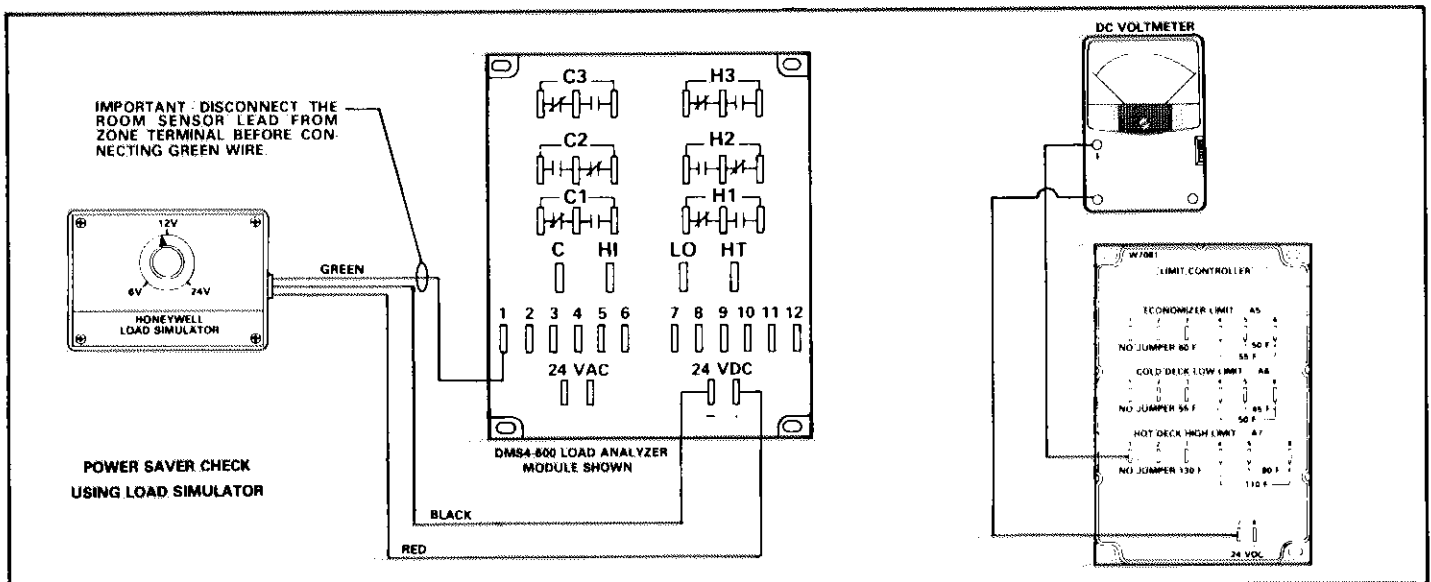

FIGURE 65

REFRIGERANT COOLING

I - REFRIGERANT COOLING SECTION

A - Compressor Compartment Identification

Refer to Figure 66 (185, 205, 300 & 360 units), Figure 67 (415 units)

and Figure 68 (600 units) for compressor compartment identification.

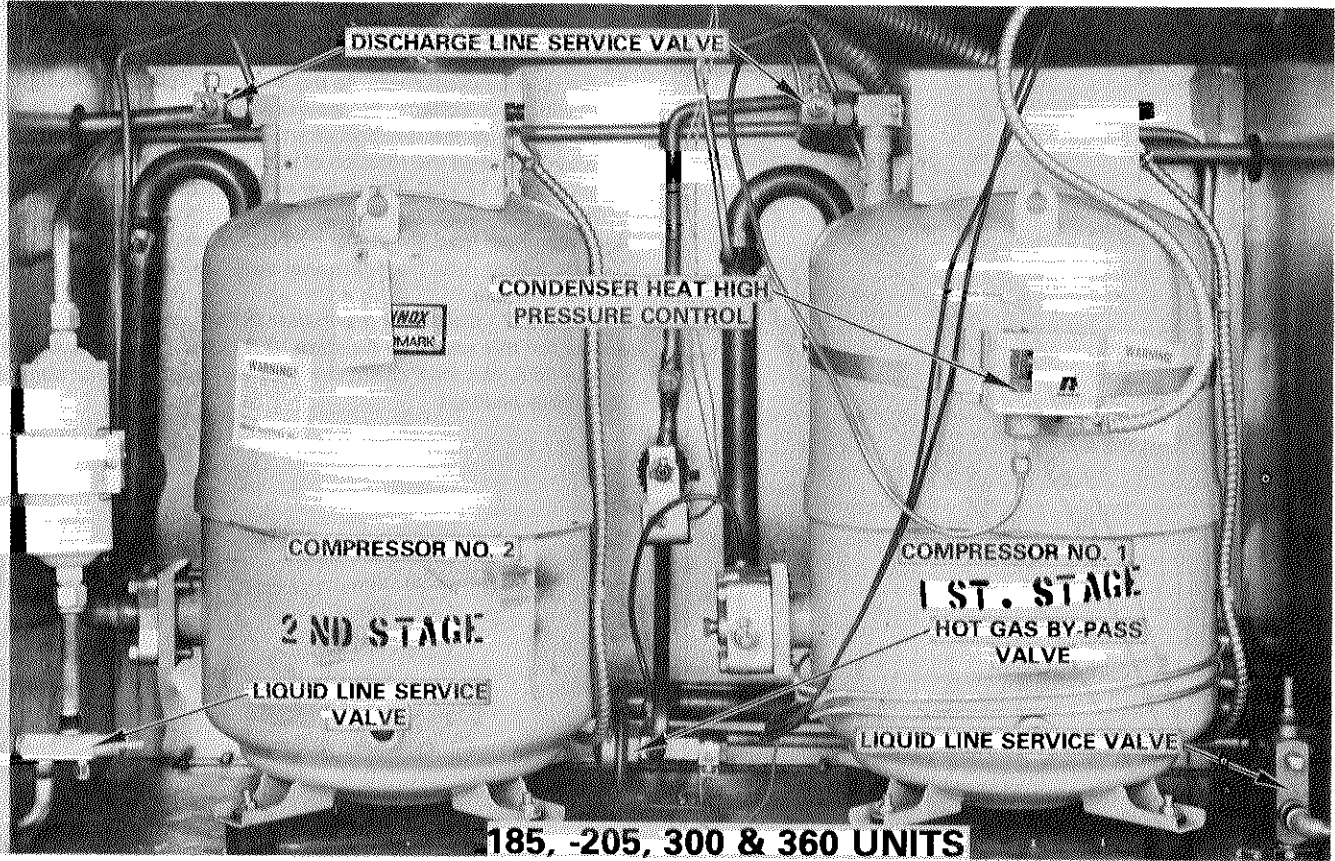

FIGURE 66

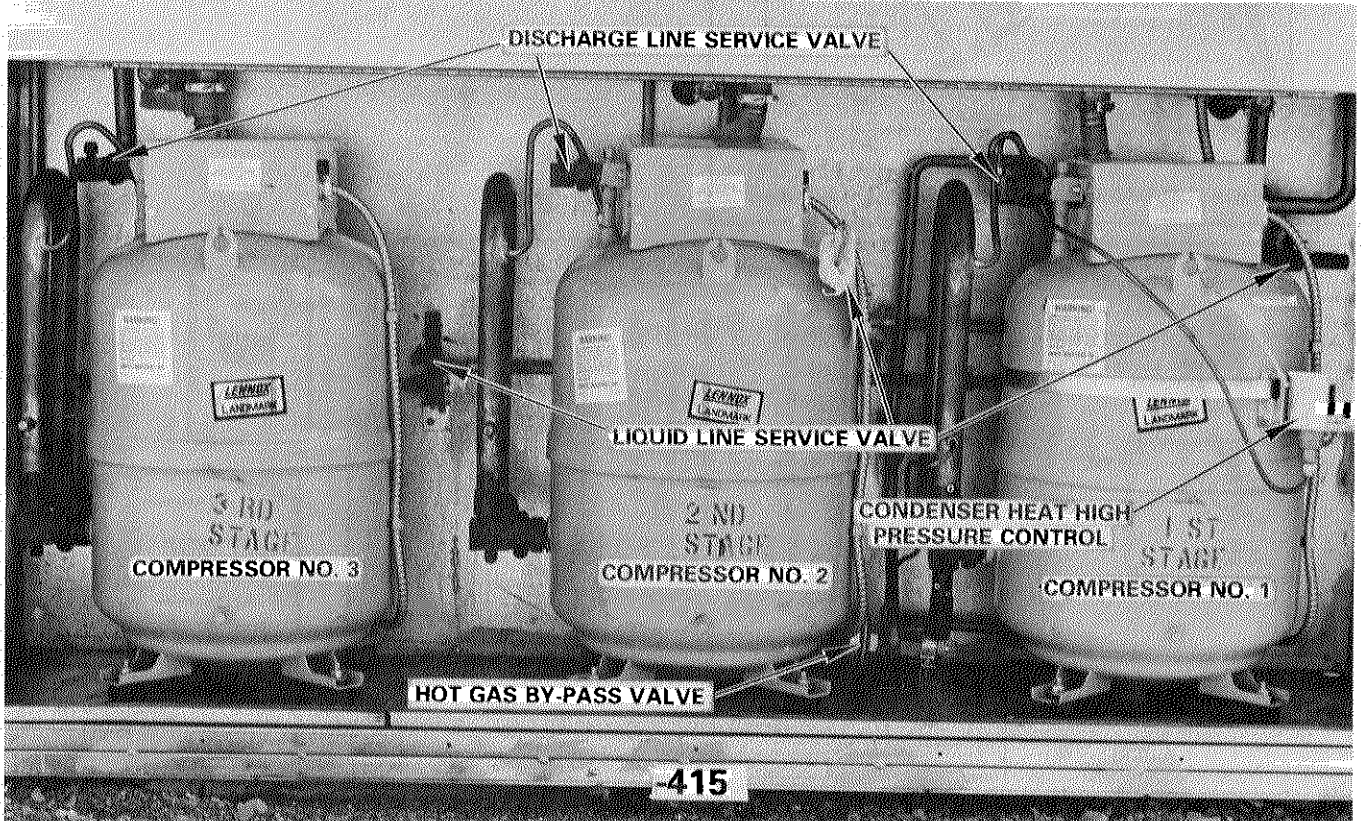

FIGURE 67

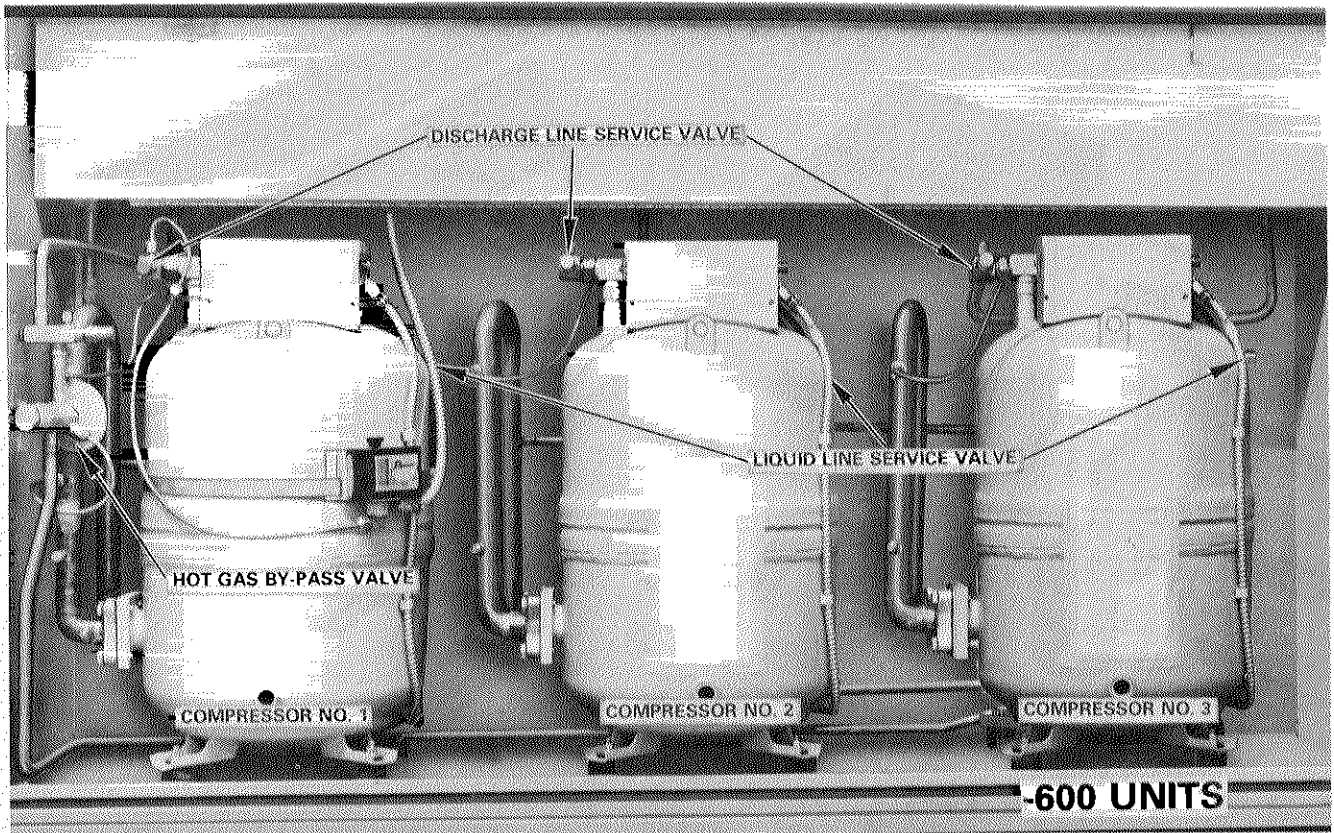
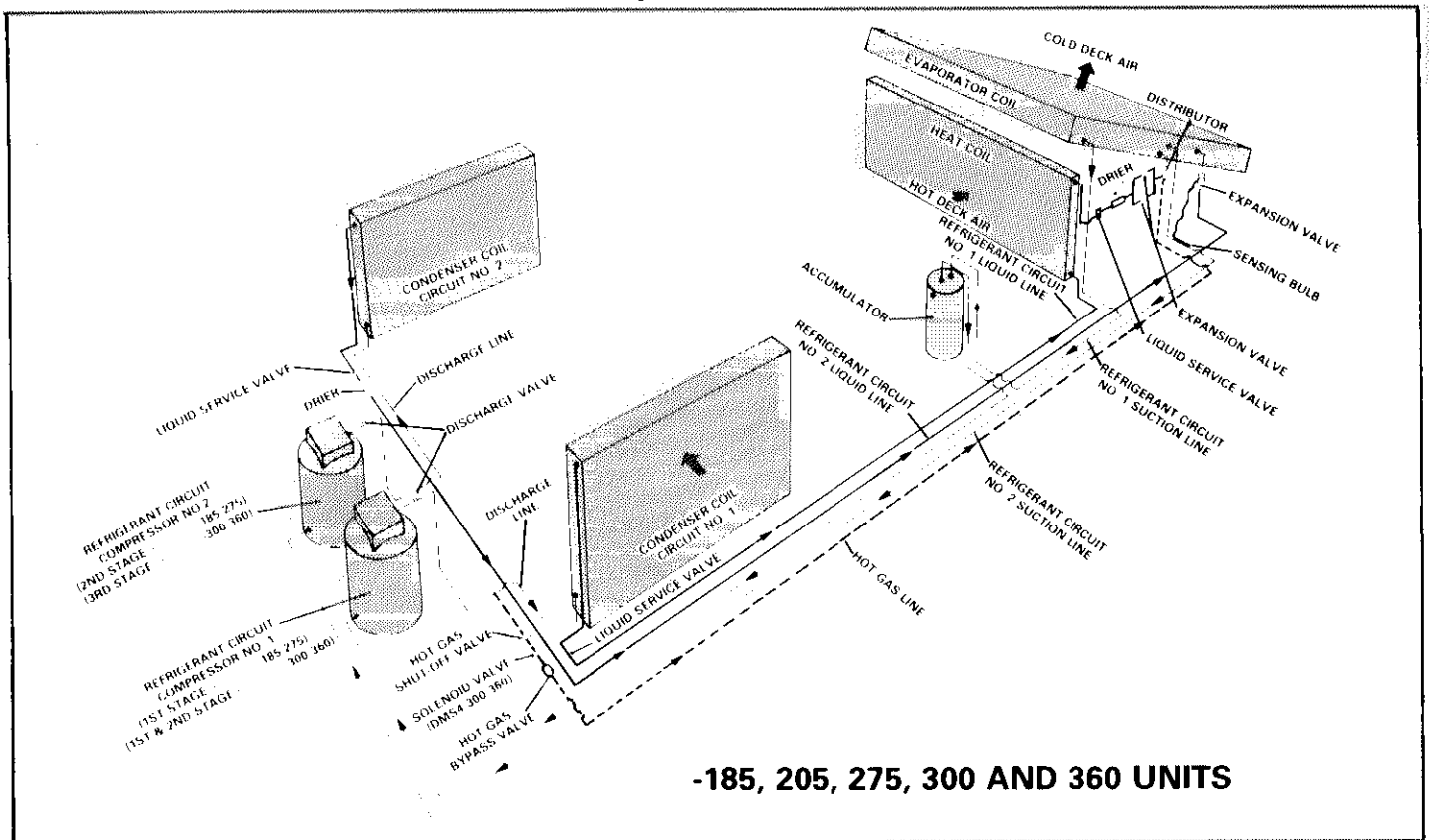

FIGURE 68

B - Refrigerant Circuiting

There is an individual refrigerant circuit for each compressor in the unit. These circuits are numbered for identification. Refer to Figure

69 (185, 205, 275, 300 & 360 units). Figure 70 (415 units) or Figure 71 (600 units) for refrigerant circuit schematics.



-185, 205, 275, 300 AND 360 UNITS

FIGURE 69

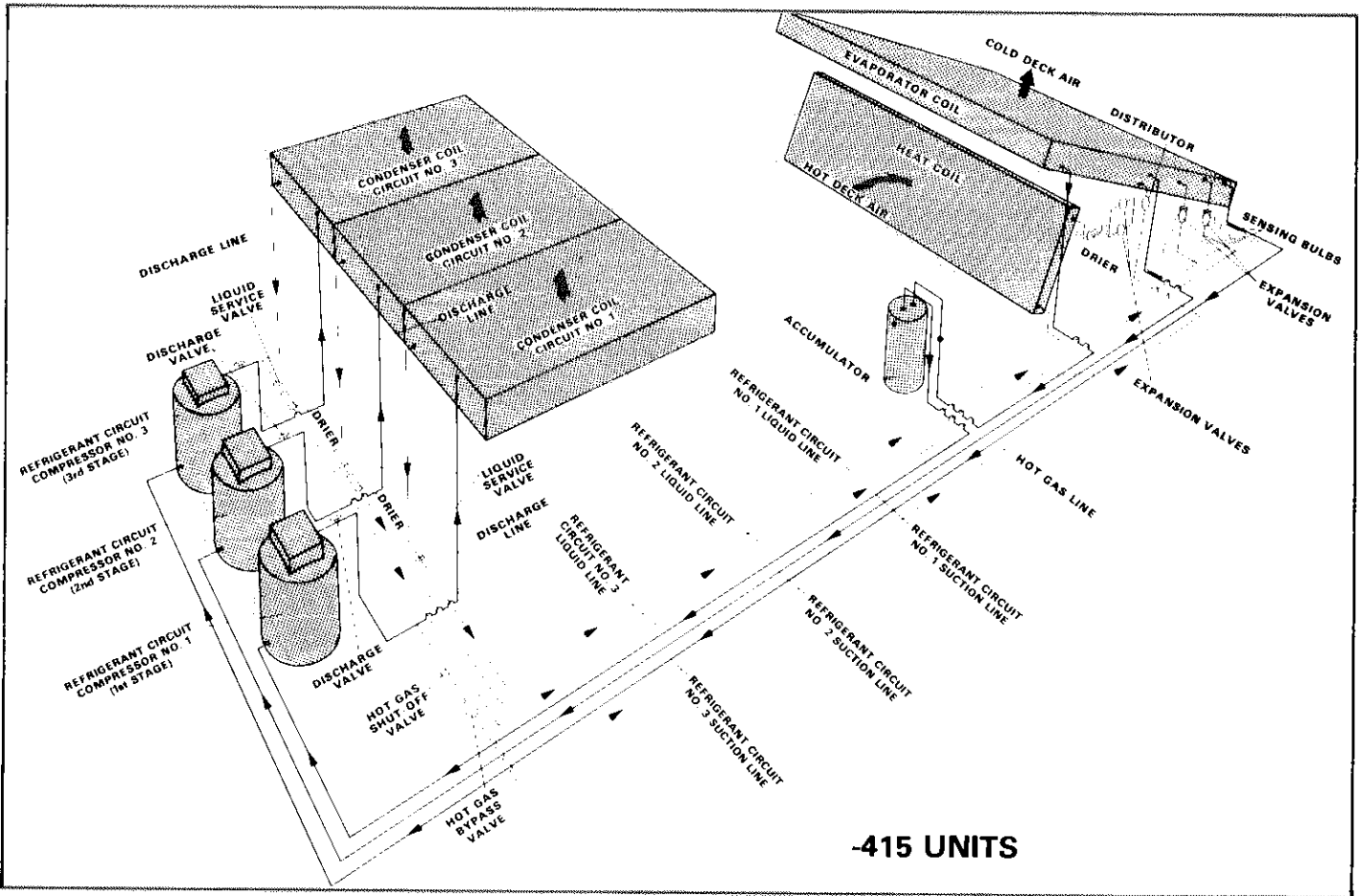

FIGURE 70

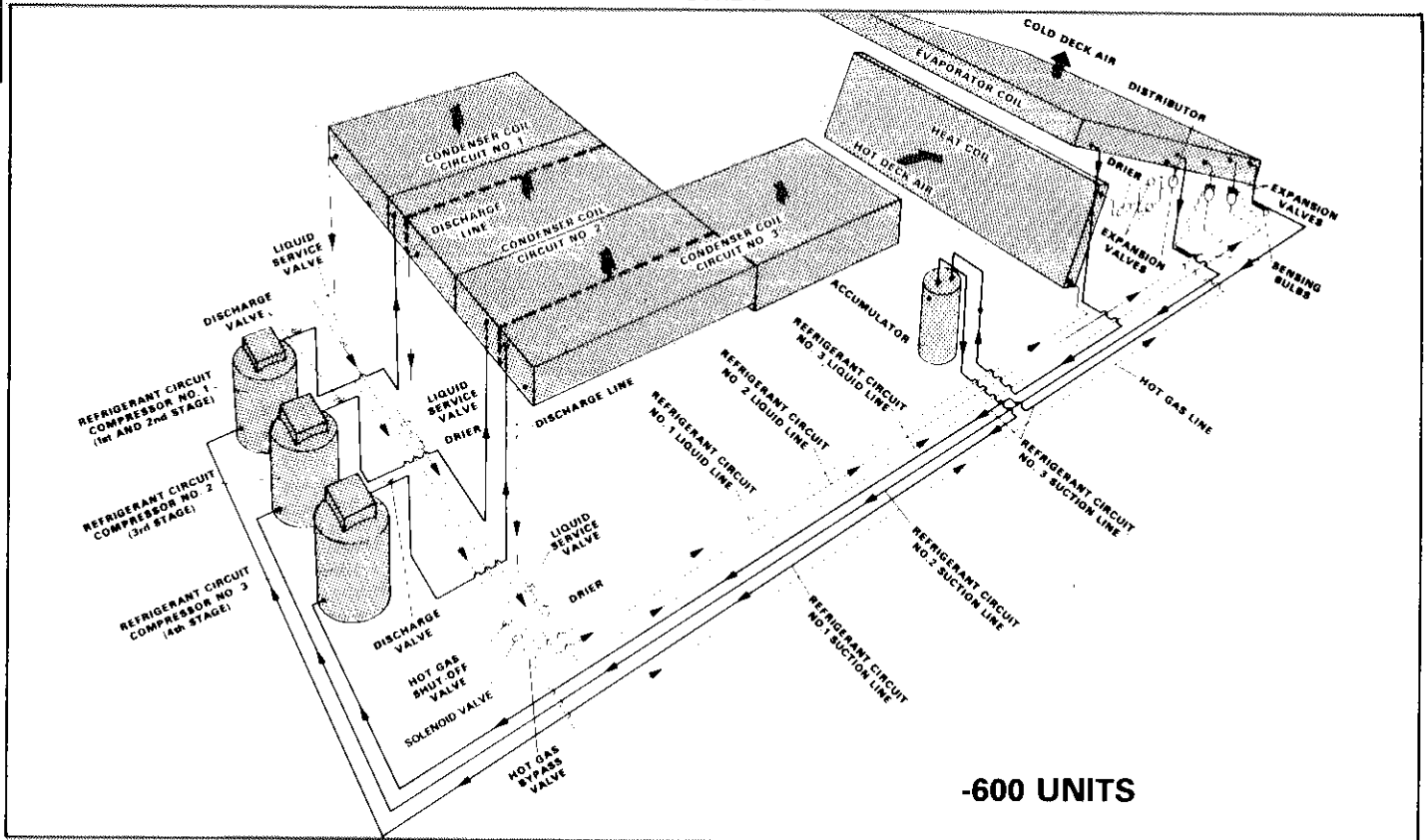

FIGURE 71

II - REFRIGERANT CONTROLS

A - Compressor Protection

Each compressor is protected by a high pressure switch (S32), a low pressure switch (S34) and a low ambient cut-out thermostat (S33). In addition 8 and 11 ton compressors use an internal cut-out thermostat (S35) and overload motor protection while the 15 ton compressors use inwinding thermistors with a protection module (A1-3). If the inwinding sensors lockout, allow one hour for protection to reset. Figures 72 and 73 show the location of these controls and Table 1 lists the various set points.

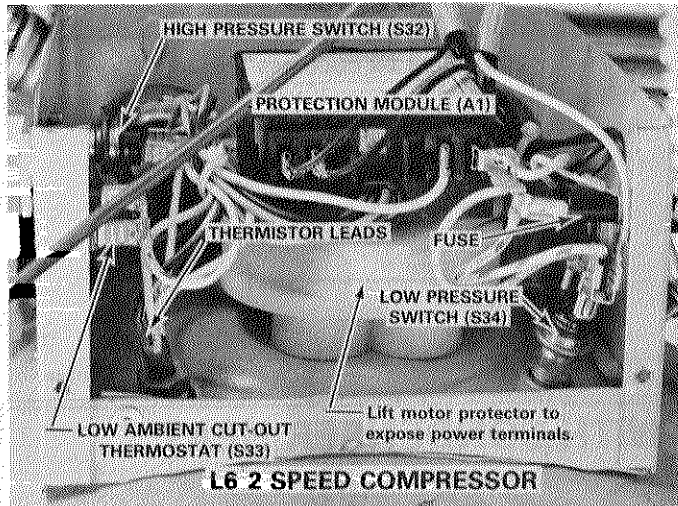

FIGURE 72

B - Hot Gas By-Pass

The no. 1 refrigerant circuit includes hot gas by-pass to prevent evaporator coil freeze-up during periods of reduced capacity. The hot gas by-pass valve opens when no. 1 circuit suction pressure drops to 58 psig (4.1 Kg/cm²). The L6 two speed compressor is equipped with an additional solenoid valve which permits hot gas by-pass operation only during low speed.

The hot gas system is also equipped with a manual main shutoff valve that must be closed to check refrigerant charge. Figures 69, 70 and 71 identify the hot gas components.

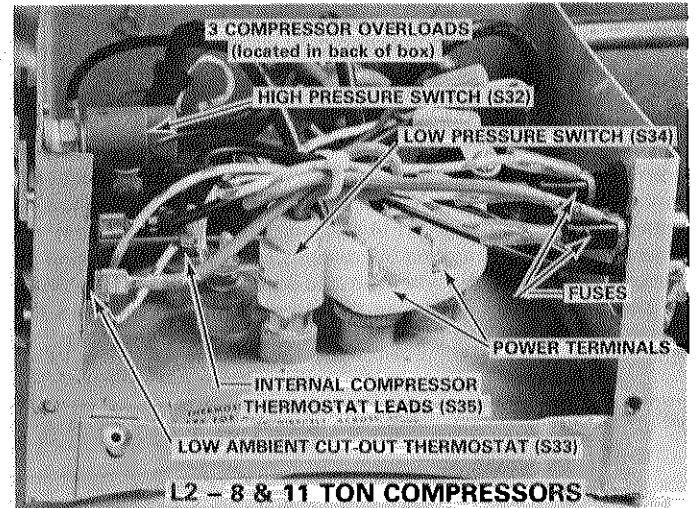

FIGURE 73

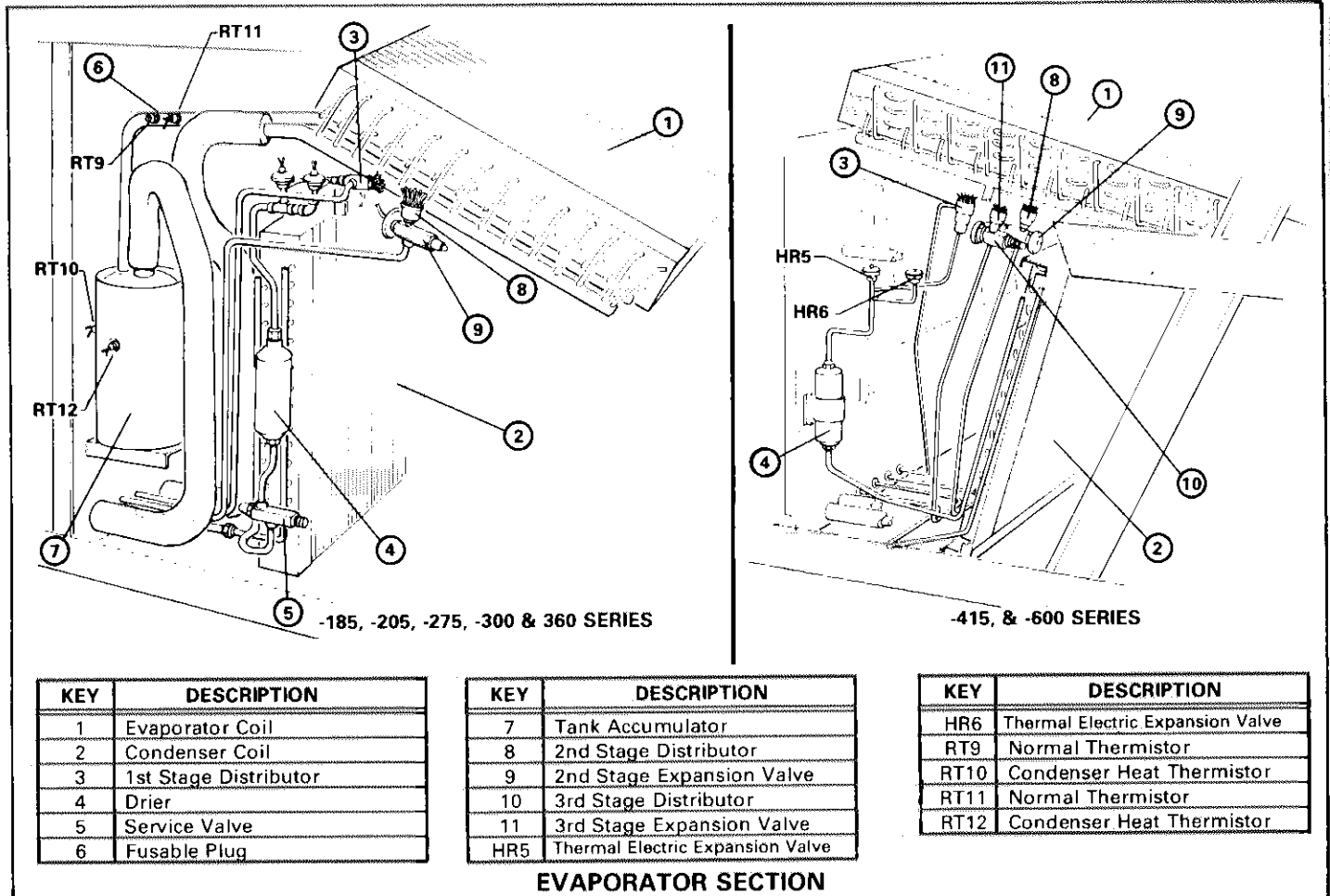

FIGURE 74

C - Condenser Heat

- 1 - A heat demand initiates the condenser heat cycle if no. 1 compressor is operating. A condenser heat demand energizes the thermistor relay (K9) to switch from the normal thermistors located on evaporator coil suction line to the suction accumulator thermistors.
- 2 - This thermistor transfer opens the expansion valve and allows refrigerant to flow into the accumulator. At this point a coil located in the hot deck now becomes the condenser and the heat which was previously expelled to the outside is added to the hot deck. Figure 74 identifies the thermistor and expansion valves.
- 3 - Figures 69, 70 and 71 illustrate the piping for condenser heat.
- 4 - A pressure switch (S1) automatically starts the condenser fan if the head pressure exceeds switch setting.

D - Overriding Limit Controls

The no. 2 limit control (A6) and RT14 cold deck sensor generate an overriding signal based upon the A9 "HI" signal and the cold deck temperature. A cold deck temperature fall causes a corresponding voltage decrease through RT14 and A6. This limit signal does not initiate the cooling command but does decrease the cooling signal to turn off the compressors when the cold deck temperature falls below set point. Figure 75 illustrates the interrelationship between the overriding controls and the rest of the cooling control system.

III - COOLING SEQUENCE (Function Chart Voltage)

The following sections exemplify the cooling command signal for each size unit. Keep in mind that although the cooling signal may indicate a cooling demand, the ambient limits and safety controls must be closed to begin compressor operation. The cold deck limit (A6) and corresponding thermistor (RT14) monitor the cold temperature to change the cooling command signal at temperatures below set point. Example: If the "HI" signal from the load analyzer is 22 VDC and asks for cool, but the cold deck temperature is already at the limit set point, A6 will control the command signal to maintain the temperature at the factory set point of 55°.

A - Chart 2 DX Cool-185-205-275

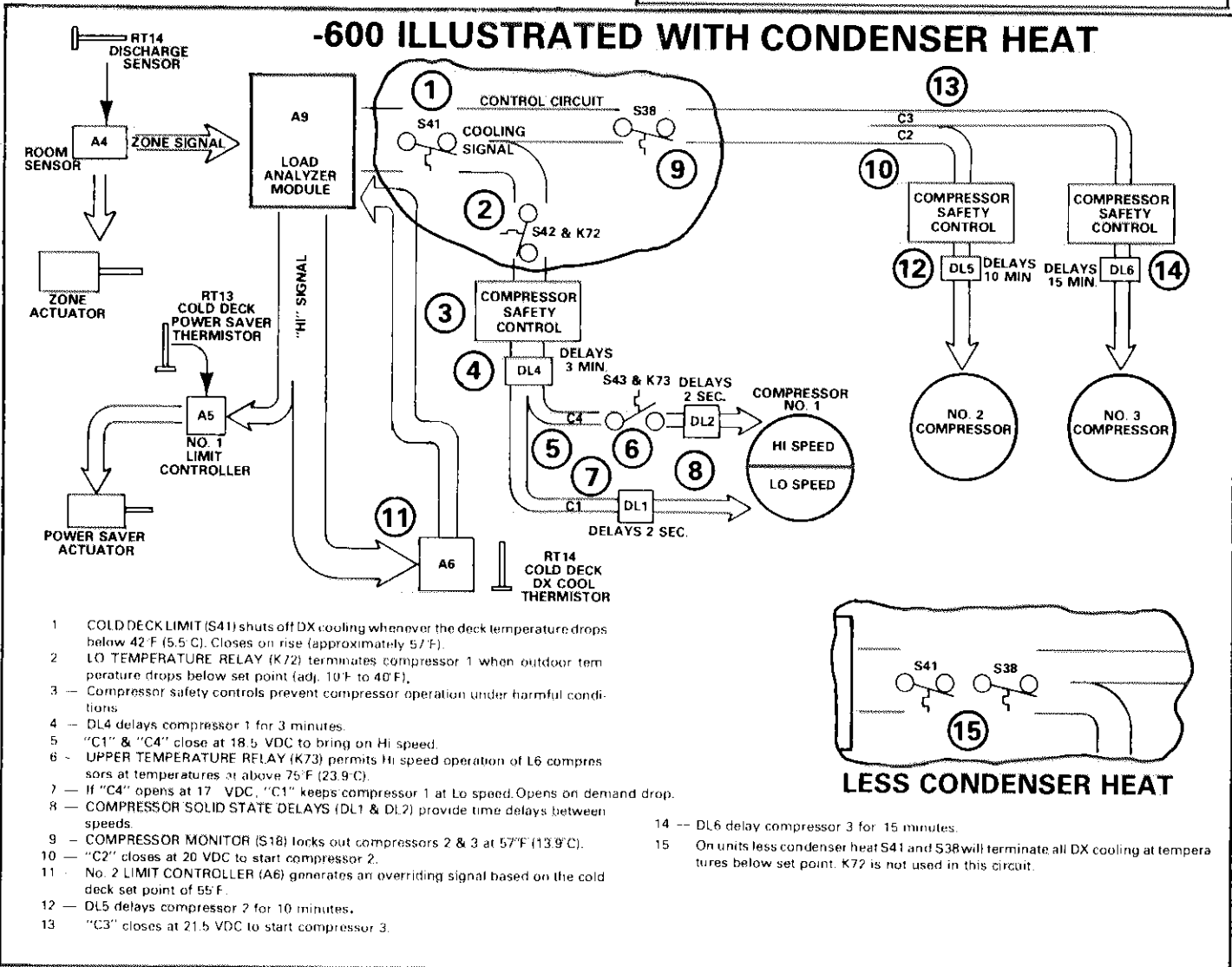
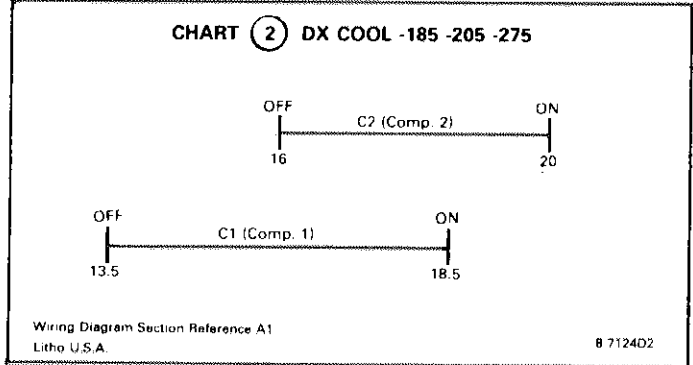
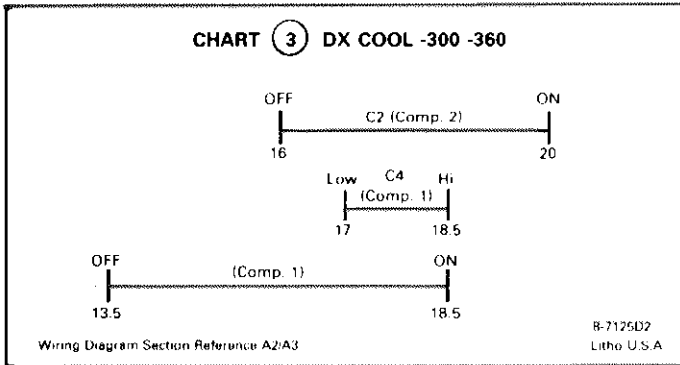

FIGURE 75

Cooling Signal

- 1 - At 18.5volts switch "C1" closes. Compressor #1 starts after a 3 minute time delay. The switch opens at 13.5volts toshut off compressor.
- 2 - At 20 5 volts switch "C2" closes. Compressor #2 starts 7 minutes after compressor 1 starts. The switch opens at 16 volts to shut off compressor. Compressor #2 has a 10 minute delay.

B - Chart 3 DX Cool -300-360



Cooling Signal

- 1 - Two switches control the operation of the two speed compressor. At 20 volts switches "C1" and "C4" are both closed to bring on high speed. "C4" remains closed until a voltage drop to 17 opens switch and transfers compressor #1 to low speed.
- 2 - Compressor #1 remains at low speed until either the voltage falls to 13.5 and "C4" opens to stop compressor or until voltage rises to 18.5 and "C4" closes to bring on high speed.
- 3 - At 20 volts switch "C2" closes and compressor #2 operates. The switch opens and shuts off compressor at 16 volts.

C - Chart 4 DX Cool -415

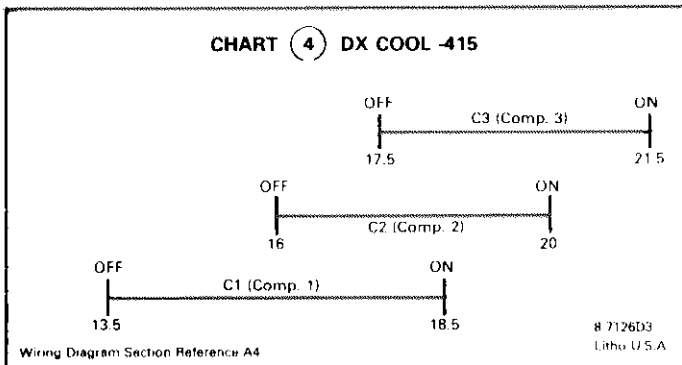

Cooling Signal

- 1 - At 18.5 volts switch "C1" closes and compressor #1 runs. The switch opens at 13.5 volts to shut off compressor.
- 2 - At 20 volts switch "C2" closes and compressor #2 runs. The switch opens at 16 volts to shut off compressor.
- 3 - At 21.5 volts switch "C3" closes and compressor #3 runs. The switch opens at 17.5 volts to shut off compressor.

D - Chart 5 DX Cool -600

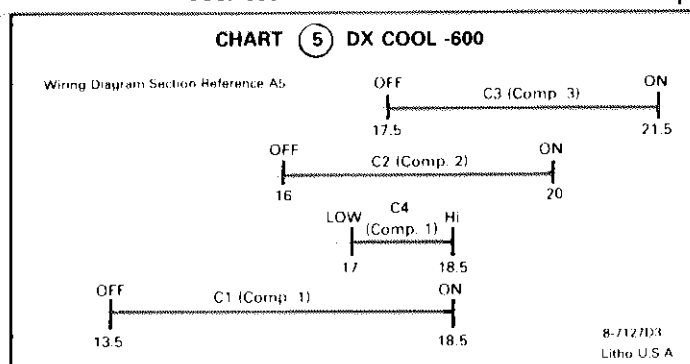

Cooling Signal

- 1 - Two switches control the operation of the two speed compressor. At 18.5 volts both switches "C1" and "C4" close to bring on high speed. "C4" remains closed until a voltage drop to 17 opens switch and transfers compressor #1 to low speed.
- 2 - Compressor #1 remains at low speed until either the voltage falls to 13.5 and "C1" opens to stop compressor or until the voltage rises to 19 and "C4" closes to bring on high speed.
- 3 - At 20 volts "C2" closes and compressor #2 runs. The switch opens at 16 volts to shut off compressor.
- 4 - At 21.5 volts switch "C3" closes and compressor #3 runs. The switch opens at 17.5 to shut off compressor.

IV - AMBIENT CONTROLS

Once the command signal initiates a cooling demand and the overriding limit signal approves, a series of ambient controls affect unit operation.

1 - Compressor Monitor

On units with condenser heat, the compressor monitor (S38) locks out no. 2 and no. 3 compressors at 57°F (13.9°C). On units less condenser heat, the compressor monitor locks out all the compressors. See Figure 76 for location.

2 - Evaporator Low Limit

The evaporator low limit (S41) terminates all DX cooling

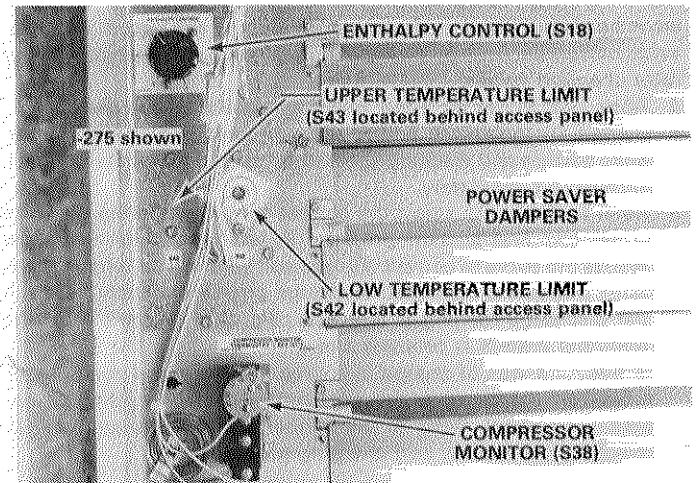

FIGURE 76

whenever the cold deck temperature falls to 42°F (5.5°C). S41 opens at 42°F ± 5°F and closes 15°F above opening point.

3 - Low Temperature Limit

On units with condenser heat, the low temperature limit (S42) and low temperature relay (K72) lockout compressor #1 when the outdoor temperature drops below the set point (adjustable 10° to 40°F). Refer to Figures 26 & 28 on pages 20 & 22 for locations.

4 - Upper Temperature Limit

On two speed compressors, the upper temperature limit (S43) and upper temperature relay (K73) do not permit high speed operation at temperatures below 75°F (23.9°C). Refer to Figures 26 & 28 on pages 20 & 22 for locations.

5 - Time Delays

DL4 delays compressor #1 for 3 minutes, DL5 delays compressor #2 for 10 minutes and DL6 delays compressor #3 for 15 minutes. Refer to Figure 27 on page 21 .

6 - Set Point Relay

Normally the cold deck set point for the limit controller (A6) is 55°F (12.8°C). Once compressor #2 starts, the set point relay (K77) shifts the setting to 50°F (10°C). This provides a longer run time for compressor #2. Refer to Figure 27 on page 21.

V - INITIAL START-UP

- 1 - Crankcase heaters **must** be energized 24 hours before starting compressor. After 24 hours install compressor fuses provided in cloth bag on compressor.
- 2 - Close main disconnect switch on unit. Indoor and return air blowers should start. If the unit has smoke detector, the blowers have a 3 minute delayed start.
- 3 - Perform the cooling check-out as instructed in this section.

VI - REFRIGERANT CHECK

- 1 - Refer to Figures 66, 67 and 68 for service valve identification. Attach gauge manifold.
- 2 - Set each room sensor to its lowest setting to provide a full cooling demand. This opens all the zone dampers to the cold deck insuring that 100% supply air goes through the evaporator coil. L6 compressors (two speed) must run at "HI" speed to check refrigerant charge. Jumper as necessary to provide manual control of compressor.
- 3 - Before checking or charging no. 1 compressor circuit, disconnect H1 and/or H2 leads at load analyzer to prevent condenser heat from being energized.

NOTE - The no. 1 compressor circuit has a hot gas by-pass valve that must be closed (front seated) before charging the circuit. This prevents refrigerant from by-passing through hot gas circuit thus giving false charging values.

- 4 - Allow unit to run for a few minutes to stabilize system.
- 5 - Using a thermometer, find condenser entering air temperature. Read suction and discharge pressures on gauge manifold. Check each circuit separately.
- 6 - Refer to Table 11 to select the correct normal operating pressure curve and find suction pressure in left-hand column. Follow across the curve to correct outdoor coil entering air temperature. Mark this point, then read discharge pressure directly below. If the discharge reading is within 3 psig (0.21 Kg/cm²) of gauge manifold system is properly charged.
- 7 - If there is a loss of charge in a circuit, remove the compressor fuses from that circuit to prevent compressor from cycling on low pressure control. Refer to the Lennox Service Manual for leak checking, evacuating and charging procedures.

8 - Table 12 lists the refrigerant charge per compressor. All condenser and condenser heat coils have 3/8" tubes while the evaporator coils have 1/2" tubes.

9 - After charging is completed, disconnect gauge manifold.

TABLE 12

| Unit | Refrigerant Charge Per Compressor | | | | | | | | | | | |
|------|-----------------------------------|------|----------|------|----------|------|------------------------|------|----------|------|----------|------|
| | With Condenser Heat | | | | | | Without Condenser Heat | | | | | |
| | Comp. #1 | | Comp. #2 | | Comp. #3 | | Comp. #1 | | Comp. #2 | | Comp. #3 | |
| | lbs. | kg | lbs. | kg | lbs. | kg | lbs. | kg | lbs. | kg | lbs. | kg |
| 185 | 32 | 14.4 | 15 | 6.7 | --- | --- | 15 | 6.7 | 15 | 6.7 | --- | --- |
| 205 | 32 | 14.4 | 19 | --- | --- | --- | 19 | --- | 19 | --- | --- | --- |
| 275 | 32 | 14.4 | 22 | 9.9 | --- | --- | 22 | 9.9 | 22 | 9.9 | --- | --- |
| 300 | 37 | 16.8 | 23 | 10.4 | --- | --- | 23 | 10.4 | 23 | 10.4 | --- | --- |
| 360 | 37 | 16.8 | 23 | 10.4 | --- | --- | 23 | 10.4 | 23 | 10.4 | --- | --- |
| 415 | 33 | 14.9 | 22 | 9.9 | 22 | 9.9 | 23 | 10.4 | 22 | 9.9 | 22 | 9.9 |
| 600 | 36 | 16.3 | 24 | 10.8 | 23 | 10.4 | 24 | 10.8 | 24 | --- | 23 | 10.4 |

VII - COMPRESSOR OIL CHARGE

Table 13 lists the correct charge per compressor and Table 14 lists the oil type. Refer to Lennox Cooling Service Handbook for correct procedure to check and add compressor oil.

TABLE 13

| Unit | OIL CHARGE | | | | | |
|------|--------------|------|--------------|------|--------------|------|
| | Compressor 1 | | Compressor 2 | | Compressor 3 | |
| | oz. | kg | oz. | kg | oz. | kg |
| 185 | 132 | 3.73 | 132 | 3.73 | --- | --- |
| 275 | 172 | 4.86 | 132 | 3.73 | --- | --- |
| 300 | 172 | 4.86 | 132 | 3.73 | --- | --- |
| 360 | 172 | 4.86 | 132 | 3.73 | --- | --- |
| 415 | 172 | 4.86 | 132 | 3.73 | 132 | 3.73 |
| 600 | 172 | 4.86 | 132 | 3.73 | 132 | 3.73 |

*L6 Compressor used on 300, 360 and 600 units only.

TABLE 11

| MODEL | SIZE UNIT | PRESSURE CURVE NUMBER | | | | | |
|-------|-----------|-----------------------|-------------|-------------|------------------------|-------------|-------------|
| | | With Condenser Heat | | | Without Condenser Heat | | |
| | | Comp. #1 | Comp. #2 | Comp. #3 | Comp. #1 | Comp. #2 | Comp. #3 |
| DMS4 | 185 | PC-7428-L9 | PC-7429-L9 | --- | PC-7429-L9 | PC-7429-L9 | --- |
| | 205 | | | | | | |
| | 275 | PC-7430-L9 | PC-7431-L9 | --- | PC-7431-L9 | PC-7431-L9 | --- |
| | 300 | PC-7432-L9 | PC-7433-L9 | --- | PC-7434-L9 | PC-7433-L9 | --- |
| | 360 | PC-7432-L9 | PC-7434-L9 | --- | PC-7434-L9 | PC-7434-L9 | --- |
| | 415 | PC-7430-L9 | PC-7431-L9 | PC-7431-L9 | PC-7431-L9 | PC-7431-L9 | PC-7431-L9 |
| | 600 | PC-7432-L9 | PC-7434-L9 | PC-7435-L9 | PC-7434-L9 | PC-7434-L9 | PC-7435-L9 |
| RVZ1 | 185 | | | | | | |
| | 205 | PC-7732-L11 | PC-7733-L11 | --- | PC-7733-L11 | PC-7733-L11 | --- |
| | 275 | PC-7734-L11 | PC-7735-L11 | --- | PC-7735-L11 | PC-7735-L11 | --- |
| | 300 | PC-7736-L11 | PC-7737-L11 | --- | PC-7738-L11 | PC-7737-L11 | --- |
| | 360 | PC-7736-L11 | PC-7738-L11 | --- | PC-7738-L11 | PC-7738-L11 | --- |
| | 415 | PC-7734-L11 | PC-7735-L11 | PC-7735-L11 | PC-7735-L11 | PC-7735-L11 | PC-7735-L11 |
| | 600 | PC-7736-L11 | PC-7738-L11 | PC-7738-L11 | PC-7738-L11 | PC-7738-L11 | PC-7738-L11 |

TABLE 14

| COMPRESSOR MODEL NUMBER | OIL TYPE |
|-------------------------|-------------|
| L2-09724 L2-12724 | Suniso 4 G |
| L2A09724 L2A12724 | |
| L2B09724 L2B12724 | |
| L2C09724 L2C12724 | |
| L2-18024 L6-18024 | |
| L2D09724 L2D12724 | Zephron 150 |
| L2A18024 L6A18024 | |

VIII - COOLING CHECK-OUT USING LOAD SIMULATOR

Connect the load simulator as shown in Figure 77 .

A - Cooling Command Signal

The following procedure will check the cooling logic relays at the

load analyzer module. Do not impose a simultaneous heating demand as the following checks are made:

- 1 - Connect DC voltmeter negative lead to 24 VDC (—) terminal and positive lead to terminal to obtain cooling command signal. Connect test lights to the cooling logic relays and No. 8 terminal of TB-C terminal strip. For ease in installing test lights, we recommend making a harness as shown .
- 2 - Refer to function chart. Slowly rotate load simulator while observing voltmeter. As the simulator raises the cooling command input voltage, the cooling logic relays will respond according to the function chart's sequence of operation. Observe test lights to verify switching action and check mechanical operation of unit.
- 3 - Slowly reverse the rotation of load simulator until output voltage recedes to 12 VDC. The cooling logic relays will open according to the chart.

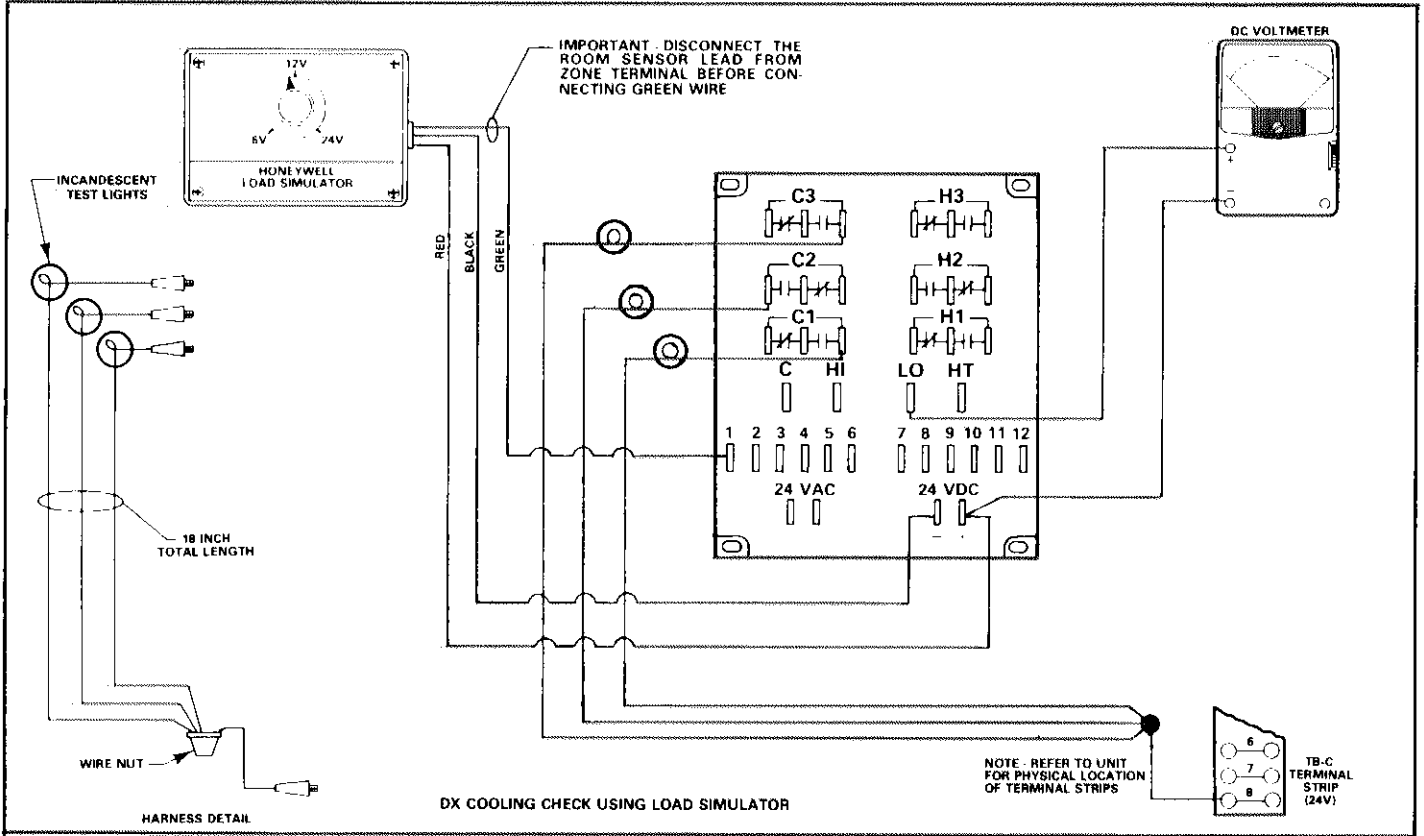

FIGURE 77

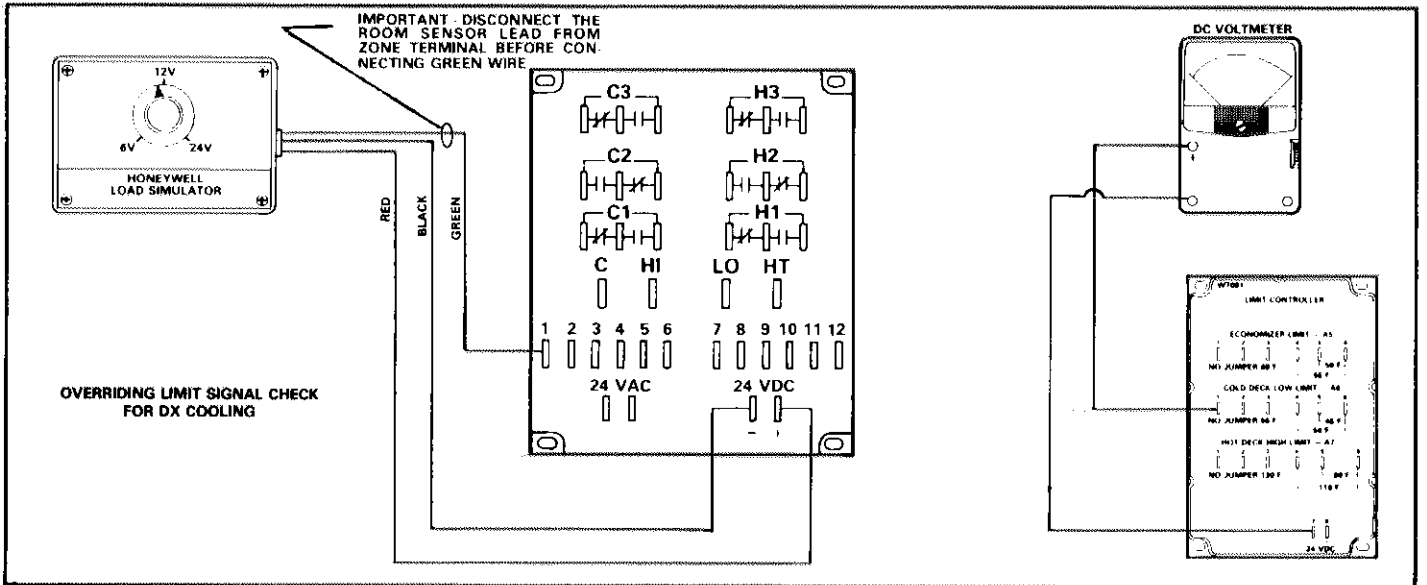

FIGURE 78

COOLING

- 4 - Disconnect load simulator, test lights and DC voltmeter from the load analyzer module.
- 5 - Reconnect the negative and positive voltage wires to the correct 24 VDC terminals.

B - Overriding Limit Signal

- 1 - Connect DC voltmeter negative lead to terminal #7 of limit controller (A6) and positive lead to terminal #1 of limit controller (A6). See Figure 78.
- 2 - Rotate Load Simulator to maximum voltage at the "HI" terminal. Compressor one should start after 3 minute delay. Voltage as measured at terminal #4 on A6 should start to drop when air across the evaporator coil is being cooled.
- 3 - If the voltage drops to 16 volts or less within the next 7 minutes

after compressor one starts, compressor #2 will not start.

- 4 - If the voltage does not drop to 16 volts or less within 7 minutes, compressor #2 will start. The voltage should then show a more rapid decrease, dropping compressor #2 at 16 volts. Compressor #2 cannot come back on until its delay time of 10 minutes expires and the voltage demand has risen to 20 volts or more.
- 5 - Compressor #3 has a dropout point of 17.5 volts, a delay time of 15 minutes and a pickup point of 21.5 volts.

IMPORTANT - Cold deck thermistor (RT14) must be sensing 55°F or above for compressor 2 & 3 to operate during this check. At temperatures below 55°F, the limit controller (A6) will lock out all compressors.

**NORMAL OPERATING PRESSURE CURVE FOR 185 & 185/275
WITH CONDENSER HEAT . . . Comp. 1-185 & 185/275**

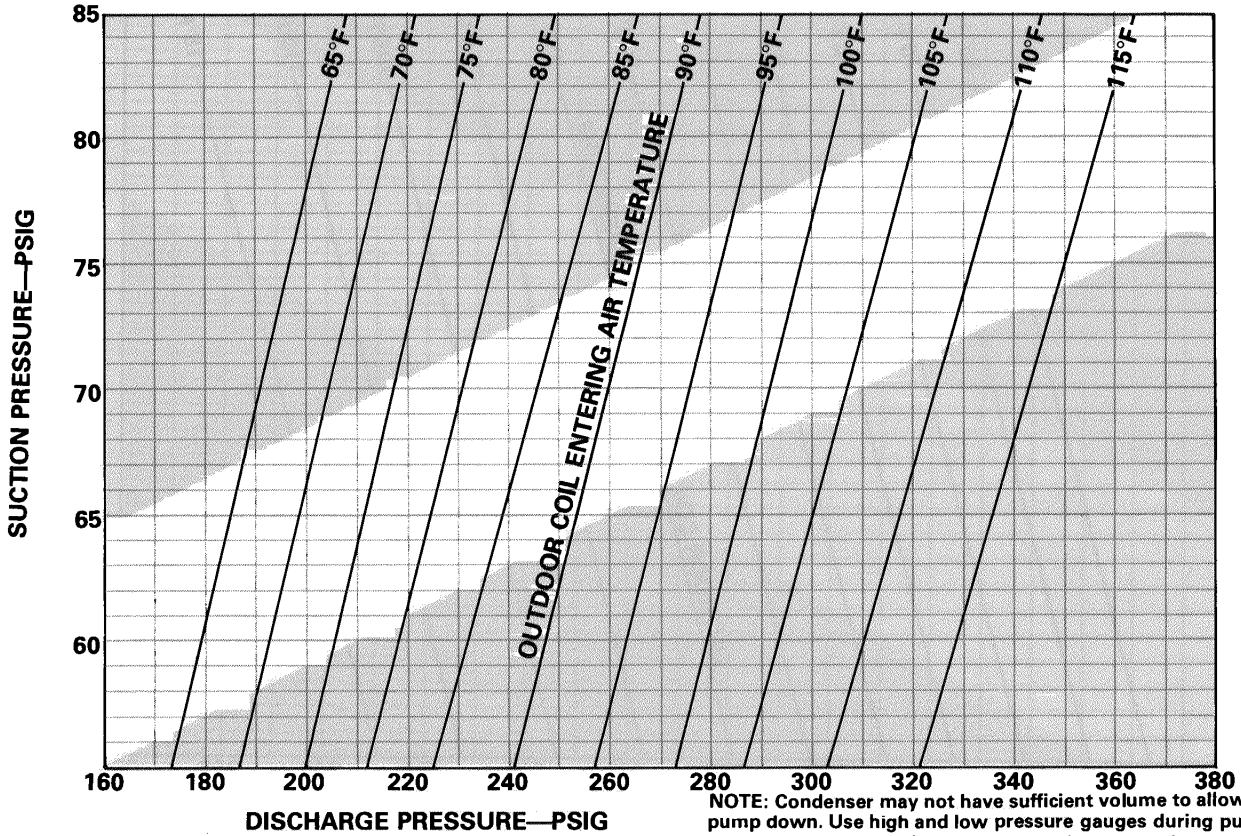

**NORMAL OPERATING PRESSURE CURVE FOR 185 & 185/275
WITH CONDENSER HEAT . . . Comp. 2-185 & 185/275
WITHOUT CONDENSER HEAT . . . Comp. 1 & 2-185 & 185/275**

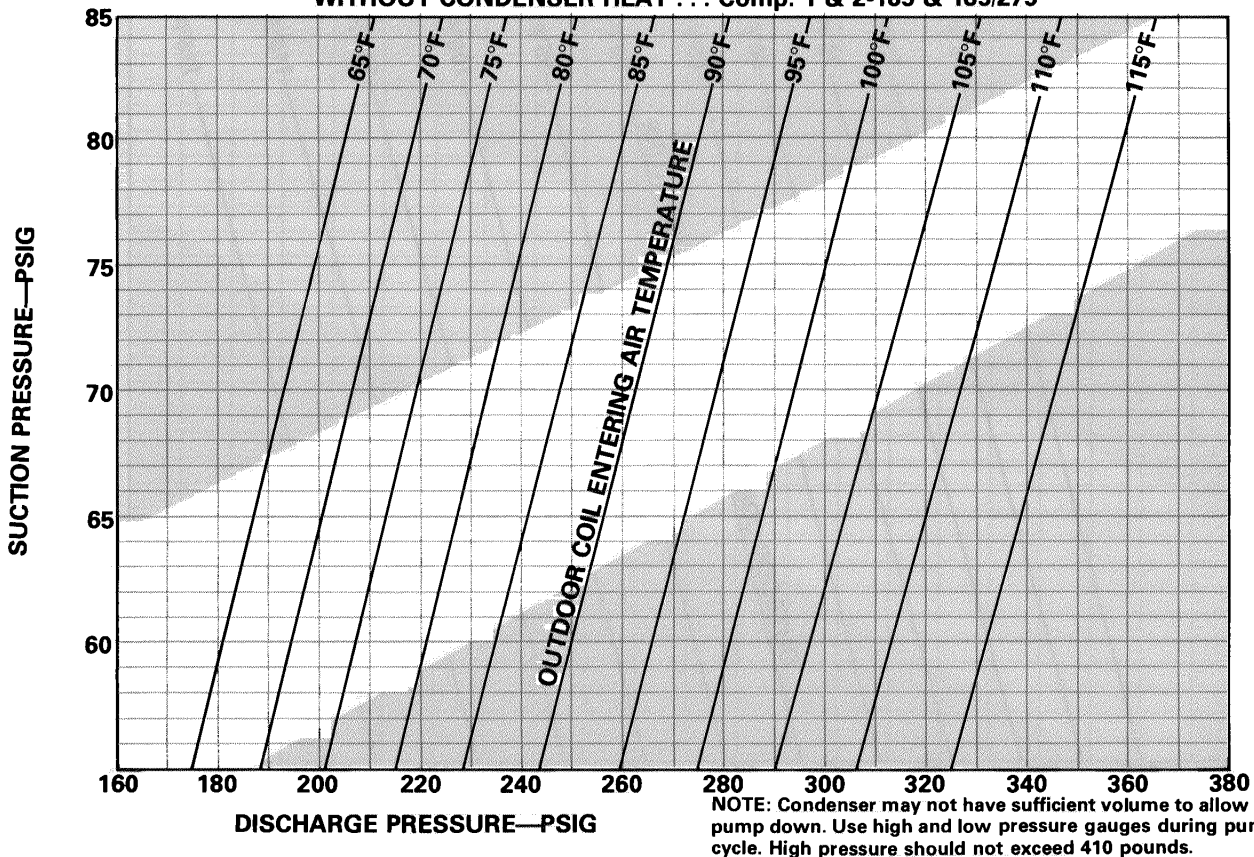

COOLING

**NORMAL OPERATING PRESSURE CURVE FOR 275 & 415
WITH CONDENSER HEAT . . . Comp. 1**

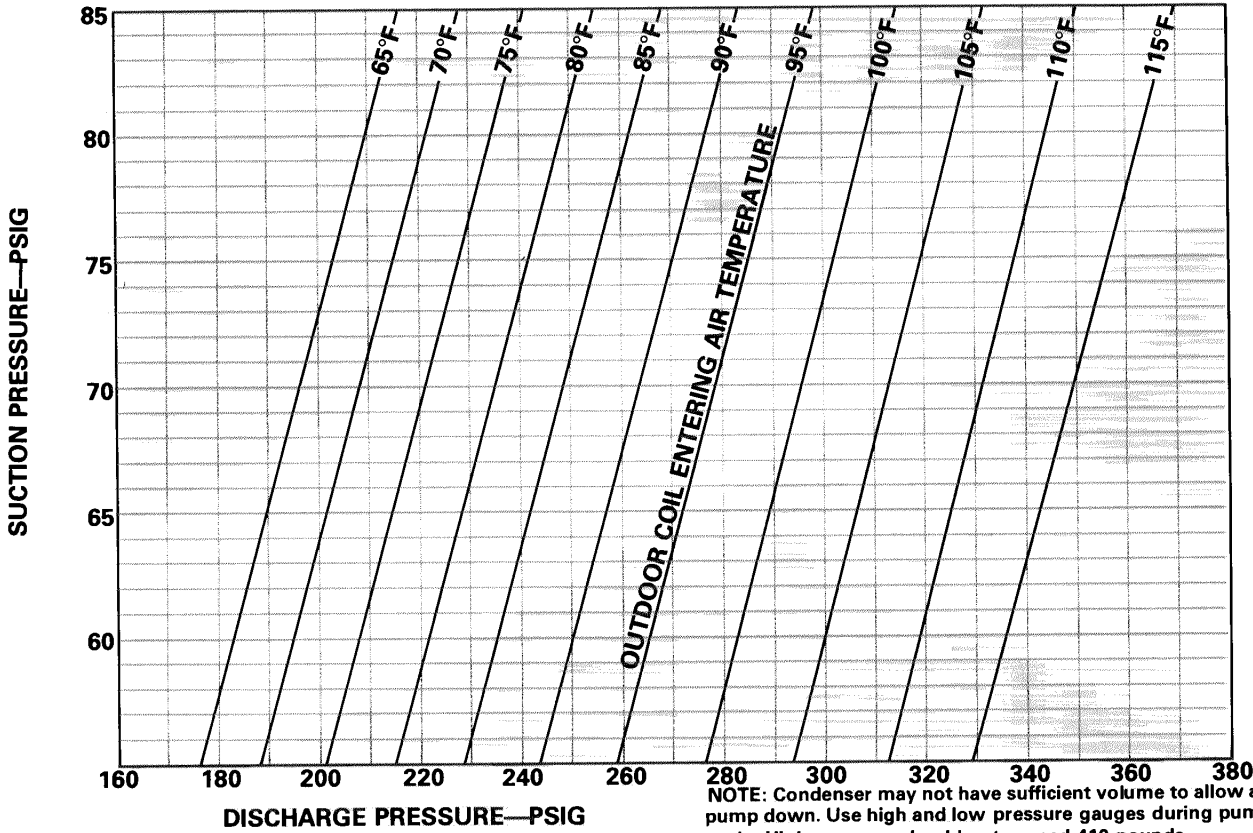

**NORMAL OPERATING PRESSURE CURVE FOR 275 & 415
WITH CONDENSER HEAT . . . Comp. 2-275 & 415 . . . Comp. 3-415
WITHOUT CONDENSER HEAT . . . COMP. 1-275 & 415 . . . COMP. 2-275 & 415 . . . COMP. 3-415**

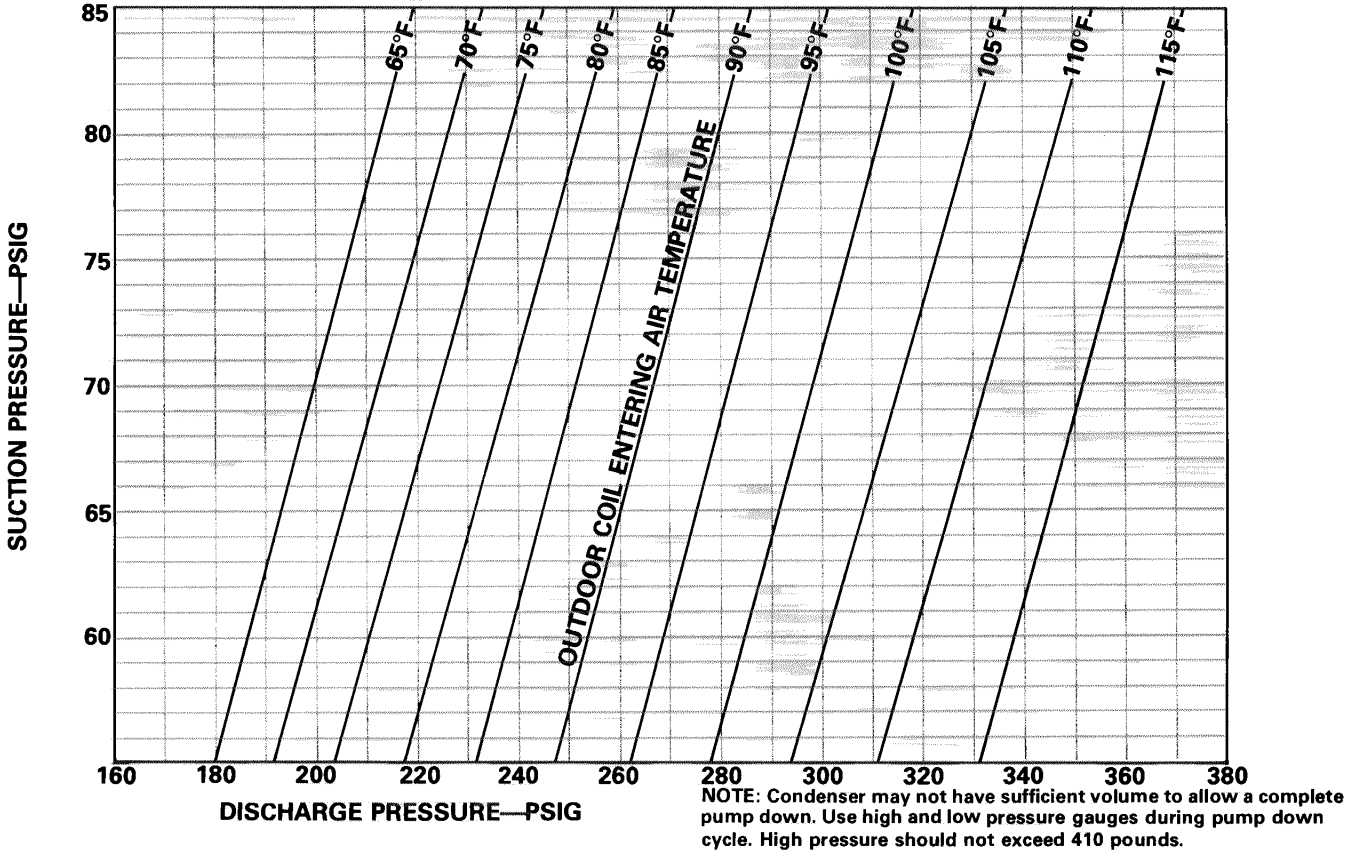

**NORMAL OPERATING PRESSURE CURVE FOR 300, 360 & 600
WITH CONDENSER HEAT . . . Comp. 1-300, 360 & 600**

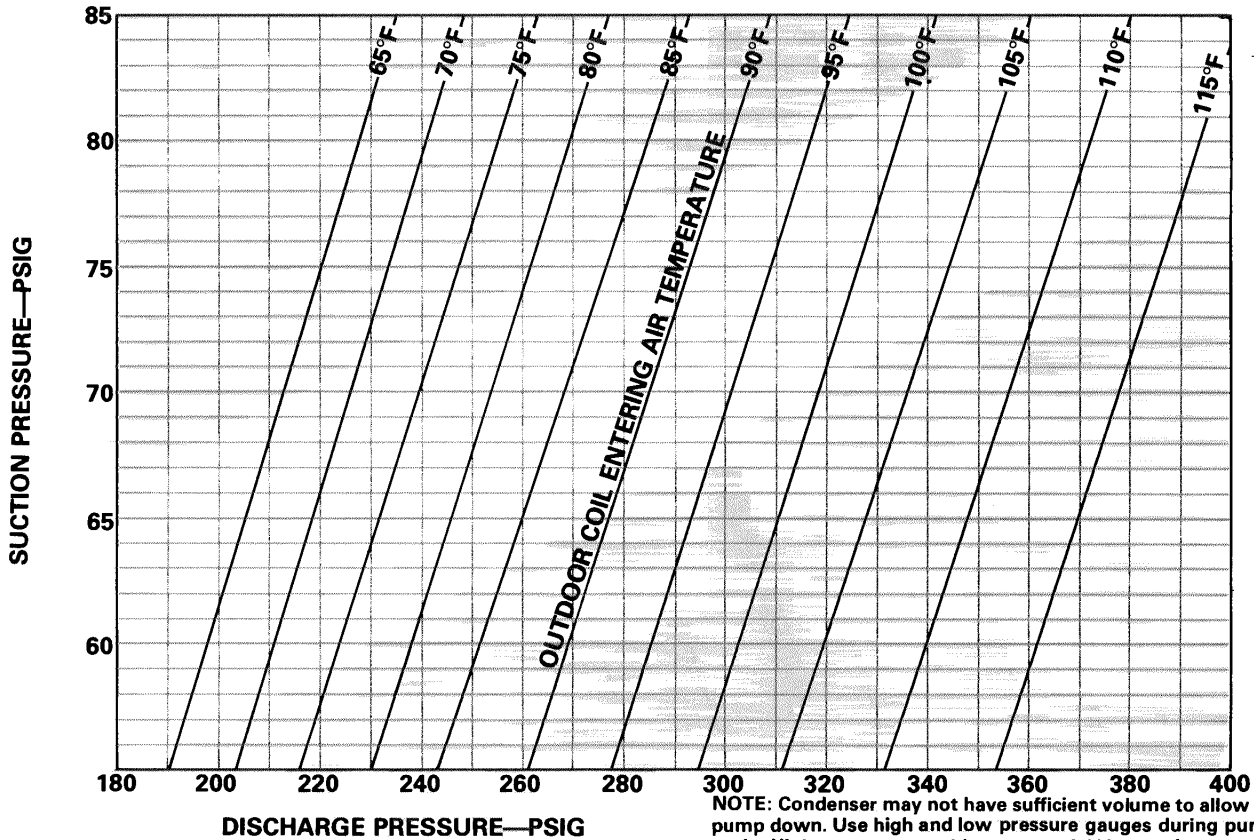

**NORMAL OPERATING PRESSURE CURVE FOR 300
WITH OR WITHOUT CONDENSER HEAT . . . Comp. 2-300**

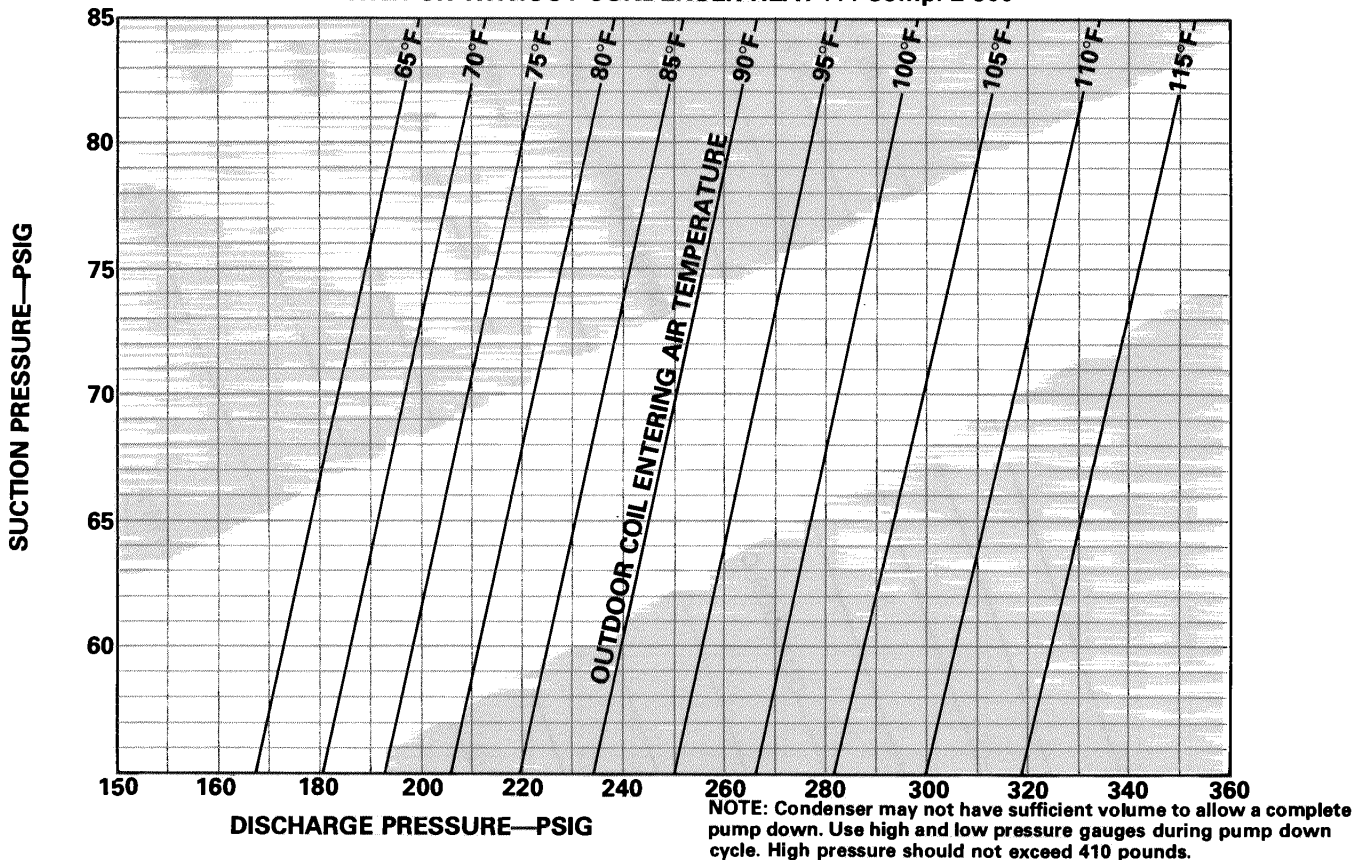

**NORMAL OPERATING PRESSURE CURVE FOR 300, 360 & 600
WITH CONDENSER HEAT . . . Comp. 2-360 & 600
WITHOUT CONDENSER HEAT . . . Comp. 1-300, 360 & 600 . . . Comp. 2-360 & 600**

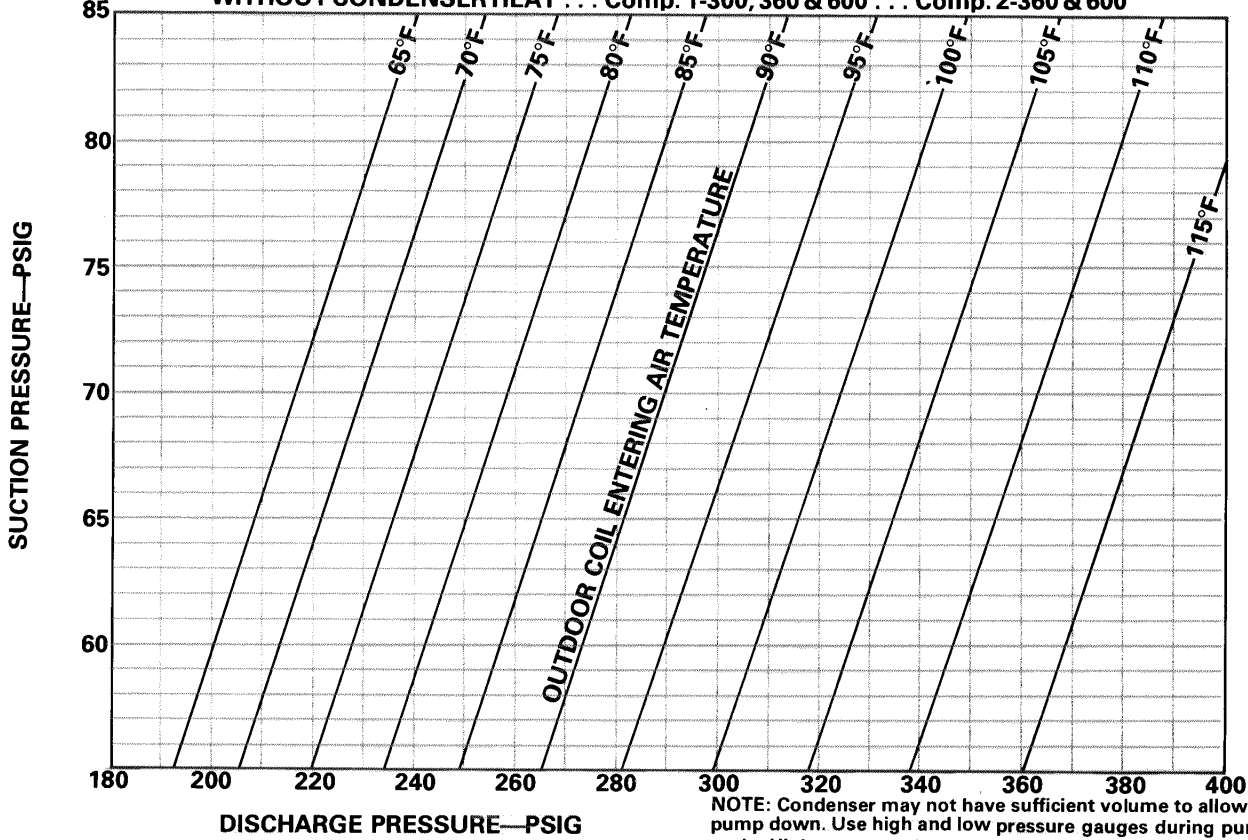

**NORMAL OPERATING PRESSURE CURVE FOR 600
WITH OR WITHOUT CONDENSER HEAT . . . Comp. 3**

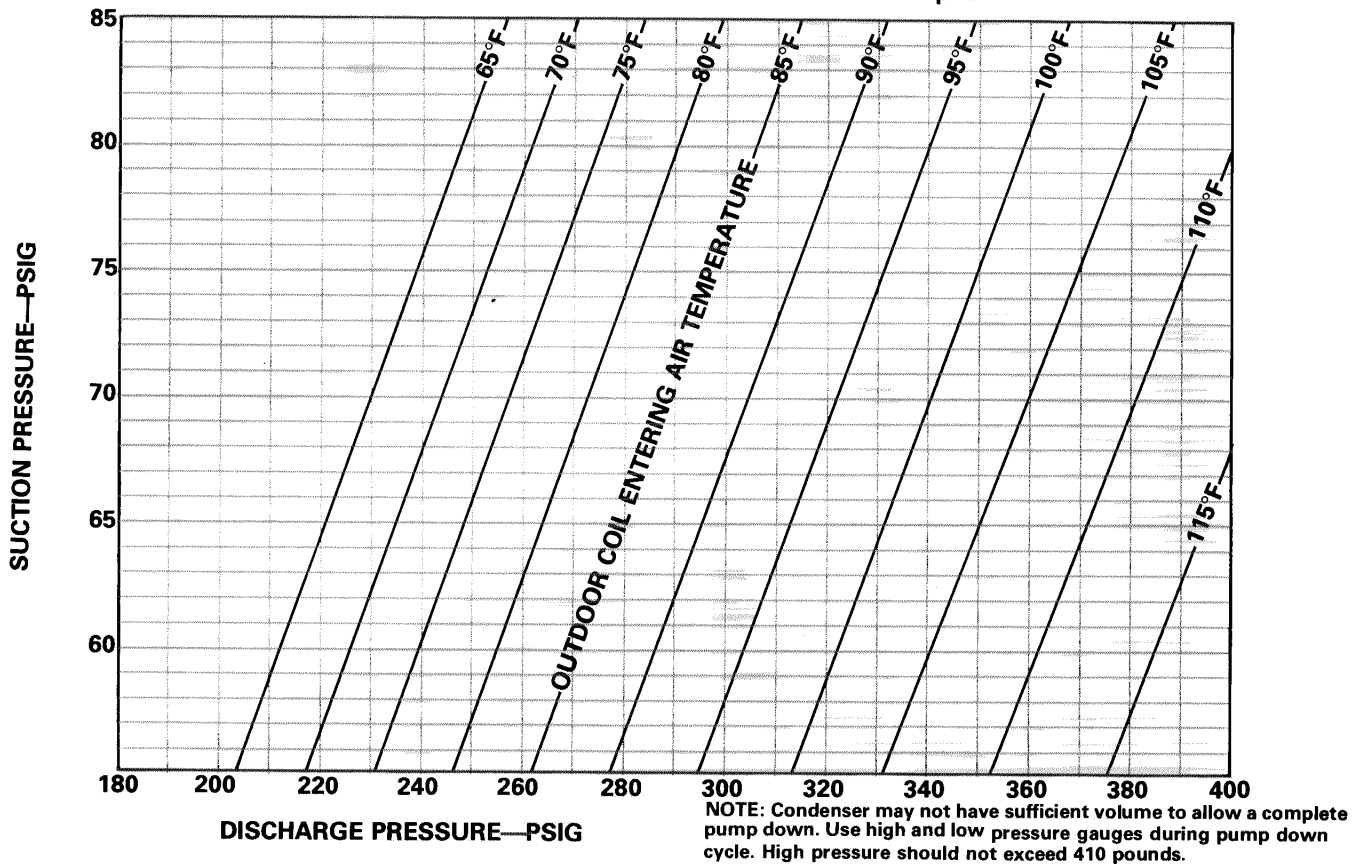

COOLING

CHILLED WATER

I - CHILLED WATER SECTION

Figure 79 identifies chilled water section. The motorized valve is secured to a support bracket for shipping. Remove the two bolts as shown.

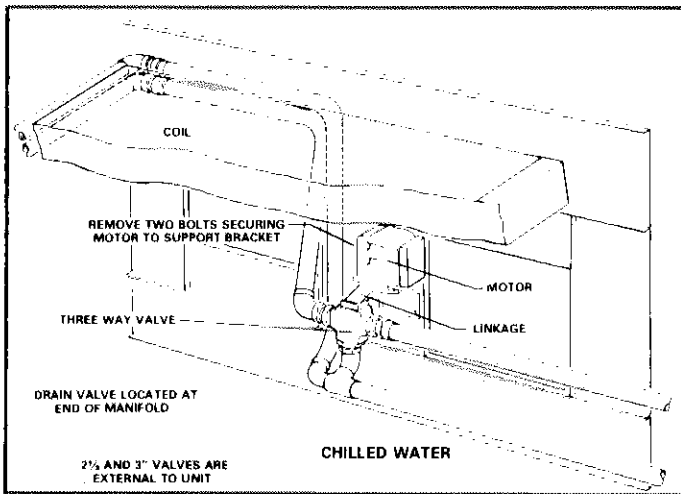
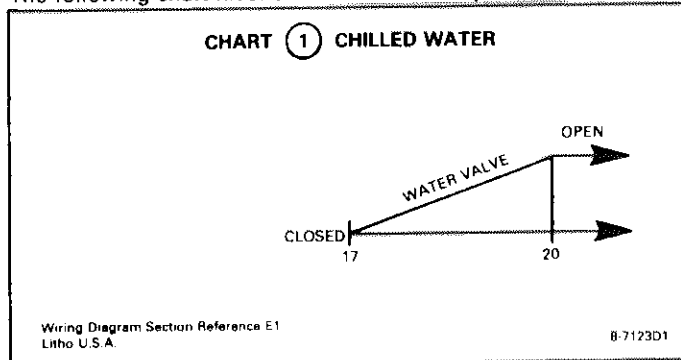

FIGURE 79

II - FUNCTION CHART

The following chart illustrates chilled water operation.



- 1 - The switches at load analyzer module are not used. The command signal from "HI" terminal controls valve modulation.
- 2 - At 17 volts or lower there is no water flow through coil.
- 3 - The valve modulates open upon a voltage increase and is fully open at 20.

The cold deck limit (A6) and corresponding thermistor (RT14) monitor the cold deck temperature to change the cooling command signal at temperatures below set point. Example: If the "HI" signal from the load analyzer is 22 VDC and asks for cool, but the cold deck temperature is already at the limit setpoint, A6 will control the command signal to maintain the temperature at the factory setpoint of 55°.

III - CHECKING VALVE

- 1 - Close main disconnect switch on unit.
- 2 - Remove wire from terminal 2 of chilled water relay (K69). Connect jumper across C and F terminals on motor. Motor should rotate clockwise lifting valve stem. Refer to Figure 80.
 - a - At end of stroke, notch in motor shaft should be down but at an angle 10° to right of vertical.
 - b - The motor should be free to run its complete stroke.
 - c - With the valve in this position, the by-pass line is open and flow to the coil is closed.
- 3 - Remove jumper across C and F terminals. Motor shaft should rotate counterclockwise, lowering valve stem. Refer to Figure 81.
 - a - At end of stroke, notch in motor shaft should be up, but at an angle 10° to right of vertical.
 - b - With the valve in this position, the by-pass line is closed and water will flow through the coil.
- 4 - Reconnect wire to terminal 2 of chilled water relay (K69).

IV - INITIAL CHILLED WATER START-UP

- 1 - Close main disconnect switch on unit. Indoor blower and return air blower should start.
- 2 - Refer to section "System Check Using Load Simulator" to check valve modulation in response to a cooling demand.

V - COOLING CHECK-OUT USING LOAD SIMULATOR

Connect the load simulator as shown in Figure 82 on page 75. The following procedure will check the "HI" signal at the load analyzer module.

- 1 - Connect DC voltmeter negative lead to 24 VDC (—) terminal and positive lead to "HI" terminal to obtain heating command signal.
- 2 - Refer to function chart. Slowly rotate load simulator while observing voltmeter. As the load simulator raises the command input voltage, the chilled water valve will modulate in response to the demand.
- 3 - Disconnect load simulator and DC voltmeter from the load analyzer module. Reconnect the negative and positive wires to the correct 24 VDC terminals.

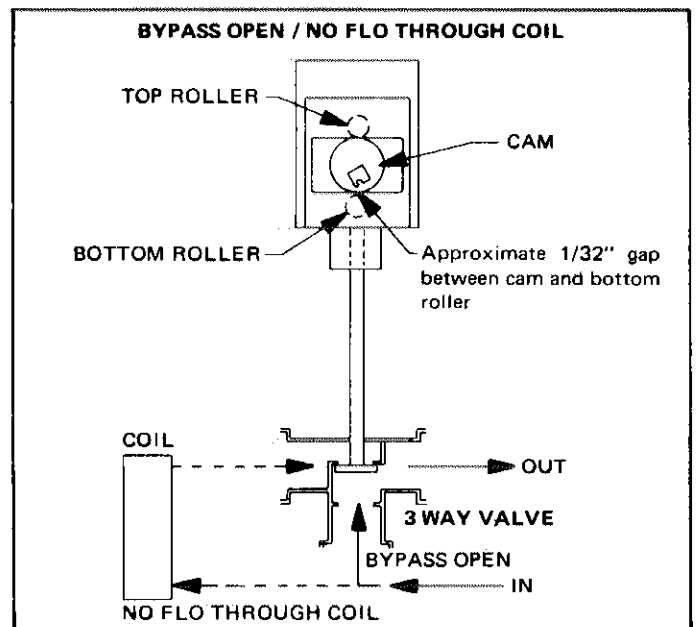

FIGURE 80

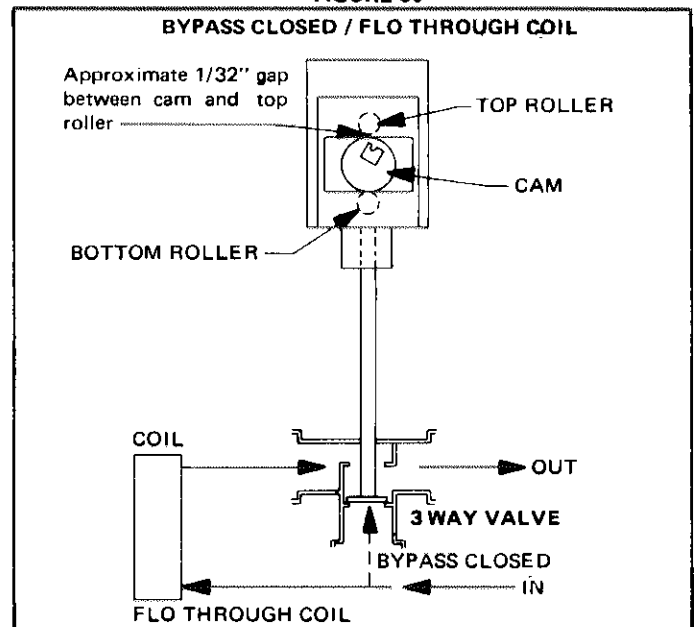

FIGURE 81

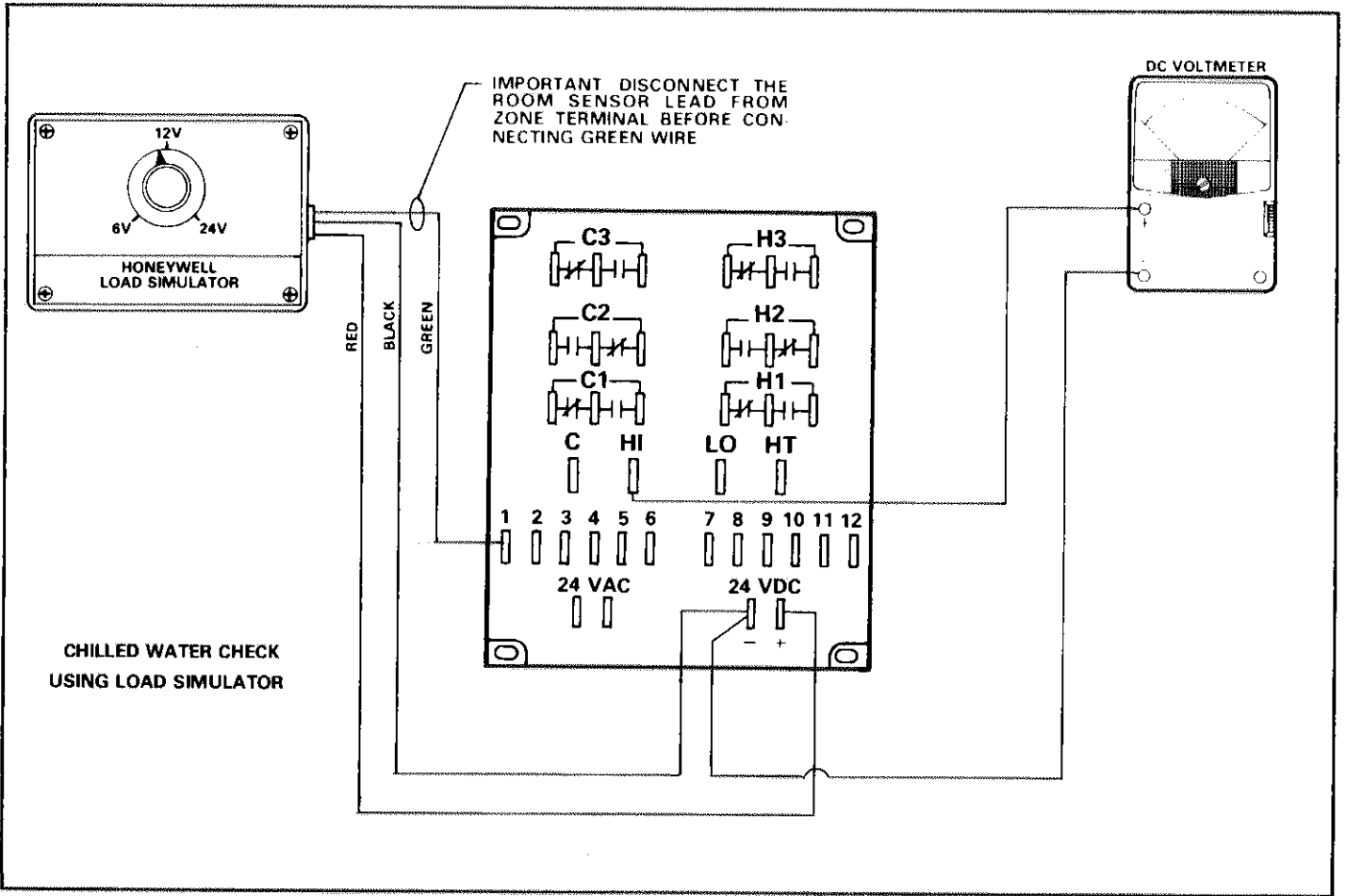

FIGURE 82

BLOWERS

I - INDOOR BLOWER AND RETURN BLOWER IDENTIFICATION
 Figure 83 identifies the indoor blower motor section for the units.

The return air blower is optional. Figure 84 designates the return air blower components for the units.

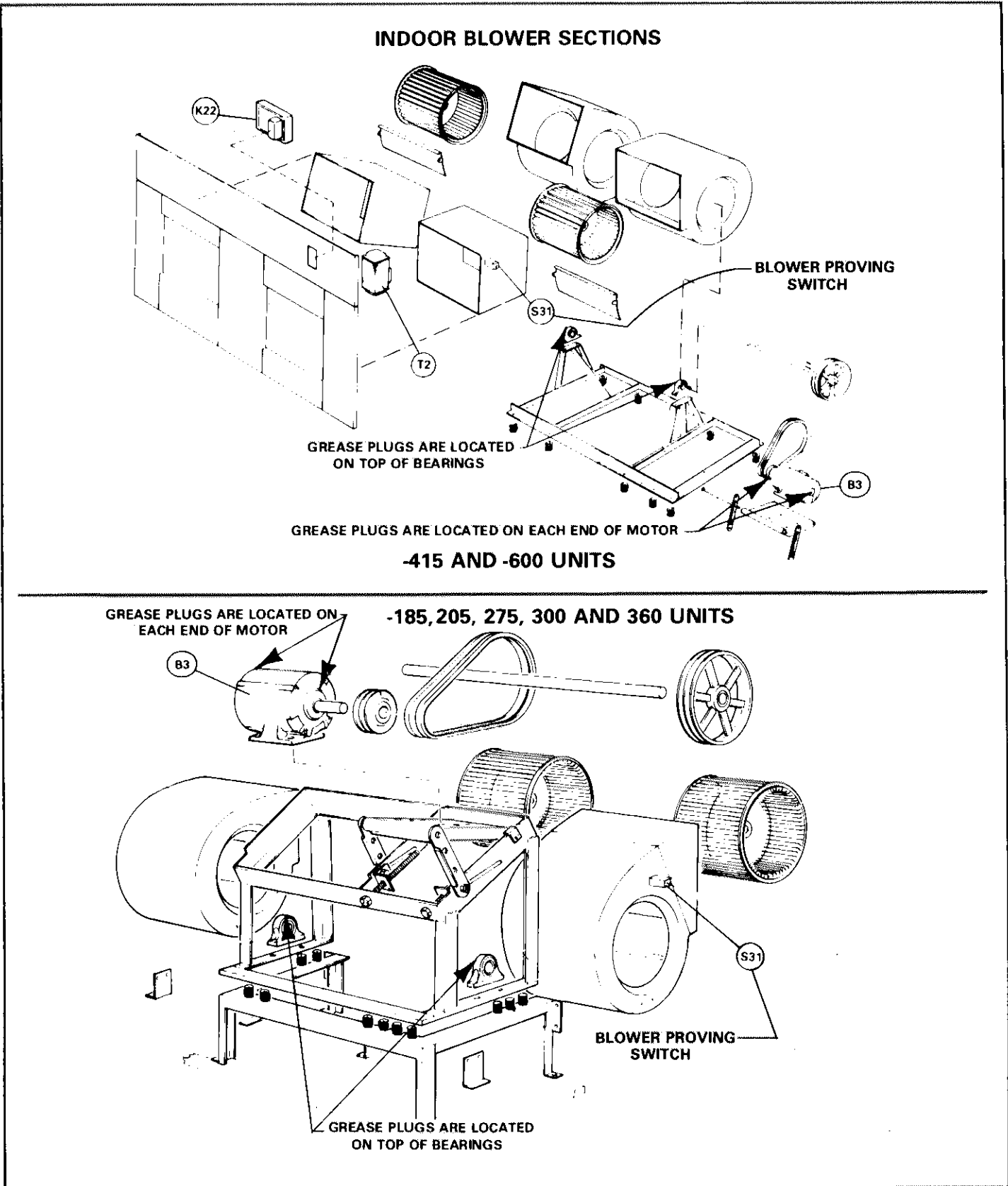

FIGURE 83

BLOWERS

RETURN AIR BLOWER SECTIONS

GREASE PLUGS ARE LOCATED ON TOP OF BEARINGS

GREASE PLUGS ARE LOCATED ON EACH END OF MOTOR

-415 AND-600 UNITS

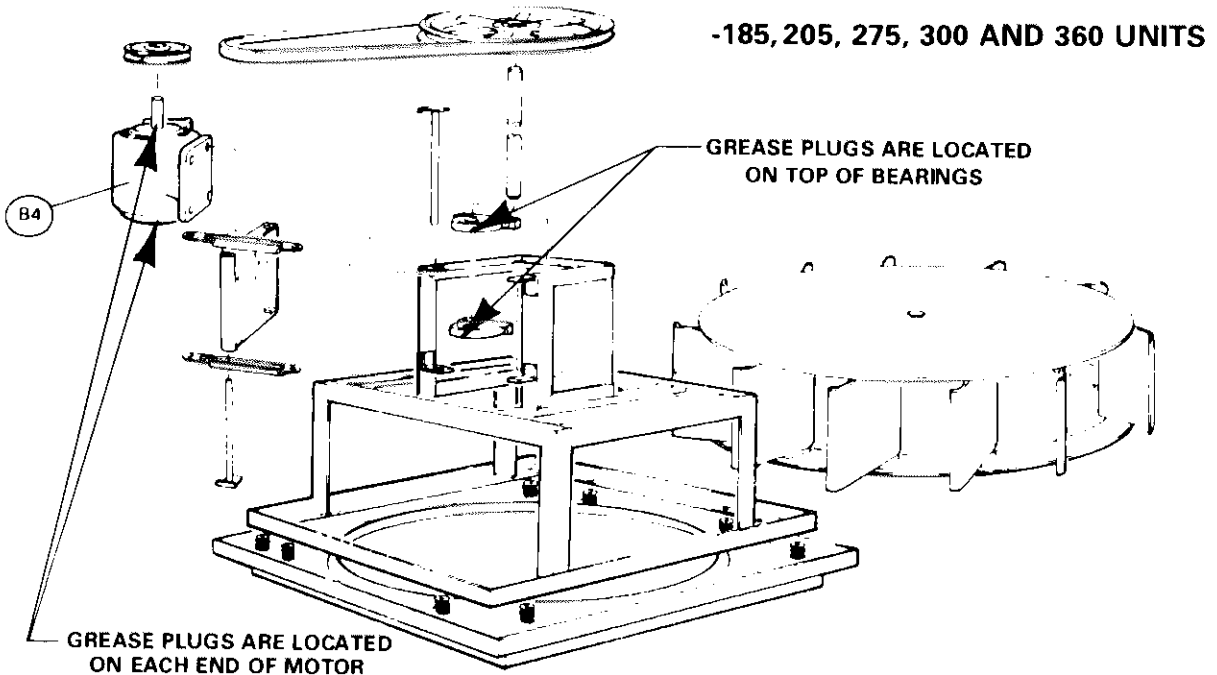

FIGURE 84

DMS4 BLOWER SECTION

I - BLOWER CONTROLS

The contactors, fusing and overloads for motors are identified within the disconnect box.

A - Blower Proving Switch

The blower proving switch senses any indoor blower motor failure and shuts down all systems within unit. See Figure 83.

B - Firestats

Firestats (manual reset) are mounted in the return and supply air streams as shown in Figures 85 and 86. They will shut off unit with temperatures in excess of 136°F (57.8°C).

II - BLOWER DRIVE SECTION

Refer to Table 15 and Table 16 for maximum usable horsepower and drive selection for both the supply air blower and return air blower.

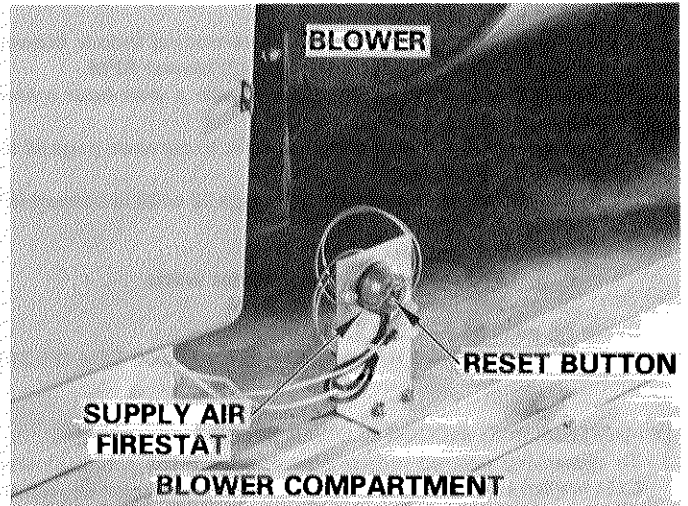

FIGURE 85

III - CHECKING INDOOR BLOWER CFM (m³/hr)

Either an amp or watt method can be used to determine indoor blower CFM (m³/hr).

A - Amp Method

Four factors are needed to determine indoor blower CFM (m³/hr); (1) measured blower RPM, (2) measured voltage, (3) blower motor amps, (4) motor manufacturer nameplate voltage and HP.

- Using blower amperage and voltage measured at unit, refer to correct Amps to Horsepower Curve on page 89, 90 and 91 to convert to HP.
- Using this HP figure, refer to curve on page 92 or 93 to convert HP and RPM to CFM (m³/hr).

Example - Readings with a 15 HP, 230 volt rated General Electric Motor.

26 Amps
230 measured voltage
800 measured blower RPM

- Curve on page 89 — 26 amps and 230 volts = 9 HP.
- Curve on page 93 — 9 HP and 800 RPM = 14,900 CFM (25 318 m³/hr).

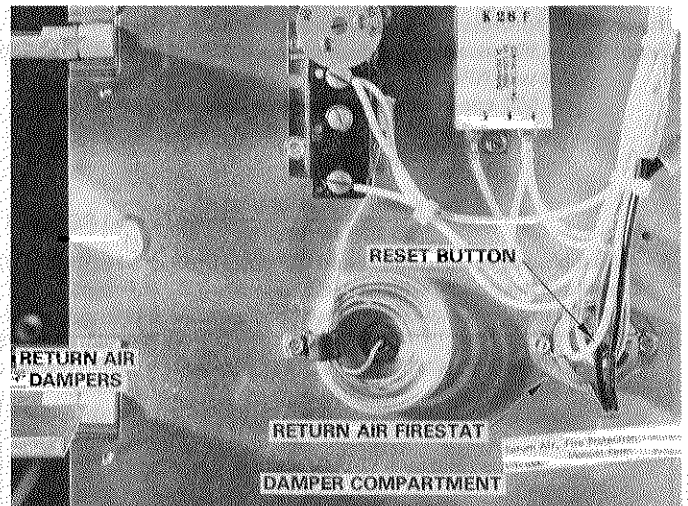

FIGURE 86

TABLE 15

| SUPPLY AIR BLOWER | | | | | | | |
|-------------------|---------------------|-----------------------------------------|-----------------------------|-----------------------------|-----------------------------|-----------------------------|-----------------------------|
| Nominal Motor Hp | **Maximum Usable Hp | Rpm Range Of All Available Drive Setups | | | | | |
| | | 185, 275, 300 and 360 Units | | 415 and 600 Units | | | |
| | | @1725 Rpm Motor Speed/60 Hz | @1440 Rpm Motor Speed/50 Hz | @1725 Rpm Motor Speed/60 Hz | @3450 Rpm Motor Speed/60 Hz | @1440 Rpm Motor Speed/50 Hz | @2880 Rpm Motor Speed/50 Hz |
| 3 | 3.45 | 595/925 | 595/760 760/900 | --- | --- | --- | --- |
| 5 | 5.75 | 595/925 | 595/760 760/900 | 515/735 | --- | 512/650 595/735 | --- |
| 7-1/2 | 8.63 | 825/915 | 840/995 890/1070 | 680/900 | --- | 680/817 748/915 | --- |
| 10 | 11.50 | *960-1030- 1095-1160 | *990-1060- 1130-1200 | *725-780- 835-890 | --- | *720-775- 830-885 | --- |
| 15 | 17.25 | --- | --- | --- | *870-910- 950-1010 | --- | *825-970 |

*Fixed sheaves.

**On 50 Hertz units, nominal motor H.P. is the maximum usable H.P.

TABLE 16

| RETURN AIR BLOWER | | | | | |
|-------------------|--------------------|-----------------------------------------|-----------------------------|-----------------------------|-----------------------------|
| Nominal Motor Hp | *Maximum Usable Hp | Rpm Range of All Available Drive Setups | | | |
| | | 185, 275, 300 and 360 Units | | 415 and 600 Units | |
| | | @1725 Rpm Motor Speed/60 Hz | @1440 Rpm Motor Speed/50 Hz | @1725 Rpm Motor Speed/60 Hz | @1440 Rpm Motor Speed/50 Hz |
| 1-1/2 | 1.72 | 351/447 | --- | 330/430 | 330/466 |
| 3 | 3.45 | 460/561 | --- | 445/545 | 466/604 |
| 5 | 5.75 | 466/561 | --- | 550/665 | 568/700 |
| 7-1/2 | 8.62 | --- | --- | 680/815 | 660/817 |

*On 50 Hertz units, nominal motor H.P. is the maximum usable H.P.

B - Watt Method (Preferred Method)

Two measured factors are needed in determining indoor blower CFM (m³/hr); (1) blower motor watts and (2) blower RPM.

NOTE - Motor watts must be determined with a watt-hour meter (watt meter).

- 1 - Using blower wattage read at motor, refer to curve on page 94 to convert watts to HP.
- 2 - Using this HP rating, refer to curve on page 92 or 93 to convert HP and RPM to CFM (m³/hr).

Example - Readings at unit

7,900 measured blower motor watts
800 measured blower RPM

- 3 - Curve on page 94 — 7,900 watts = 9 HP.
- 4 - Curve on page 93 — 9 HP and 800 RPM = 14,900 CFM (25 318 m³/hr).

IV - DETERMINING INDOOR BLOWER SPEED

1 - To determine desired indoor blower speed, the actual blower CFM (m³/hr) and blower RPM must be found as shown in section "IV" - Checking Indoor Blower CFM (m³/hr).

These factors plus the specified indoor blower CFM (m³/hr) can be made into a formula to calculate correct blower speed.

Example - 14,900 measured indoor blower CFM (25 318 m³/hr) at 800 blower RPM.

14,000 specified indoor blower CFM (23 788 m³/hr).

$$\frac{14,000 \text{ CFM} \times 800 \text{ RPM}}{14,900 \text{ CFM}} = 750 \text{ RPM}$$

$$\frac{23 \text{ 788 m}^3/\text{hr} \times 800 \text{ REV}/\text{MIN}}{25 \text{ 318 m}^3/\text{hr}} = 750 \text{ REV}/\text{MIN}$$

- 2 - Adjust blower drive to the speed (RPM) as instructed in Figure 87 or replace the pulley, whichever is necessary. 10 H.P. and 15 H.P. motors use fixed sheaves which must be replaced to change speed.

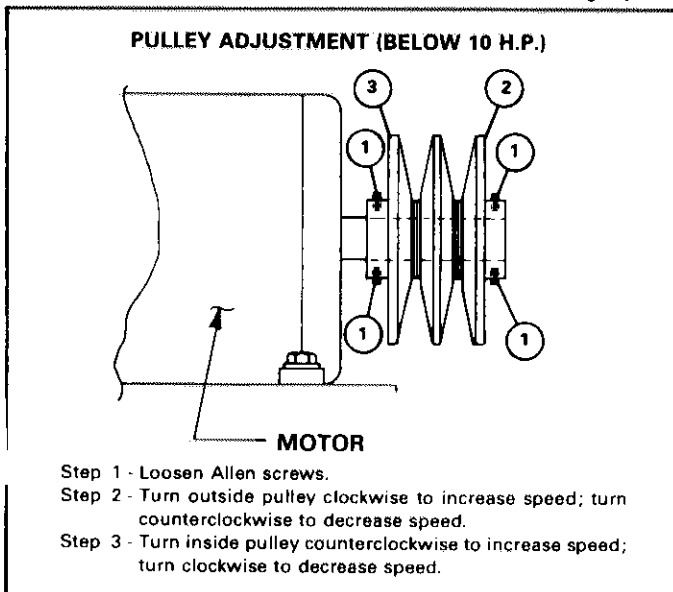

FIGURE 87

V - CHECKING INDOOR AND RETURN AIR BLOWER MOTOR AMPERAGE

It is mandatory that the blower motor amperages be checked on every DMS4 unit to be sure the motors are not overloaded.

- 1 - Open exterior panel exposing the electrical box.
- 2 - Turn handle to open electrical box. This disconnects power to the unit.

WARNING - Box contains high voltage - use extreme caution.

- 3 - 415 and 600 Units Only - Remove indoor and return air blower motor contactor access panel. Refer to Figure 88.
- 4 - Attach amp meter and then turn "On" disconnect.

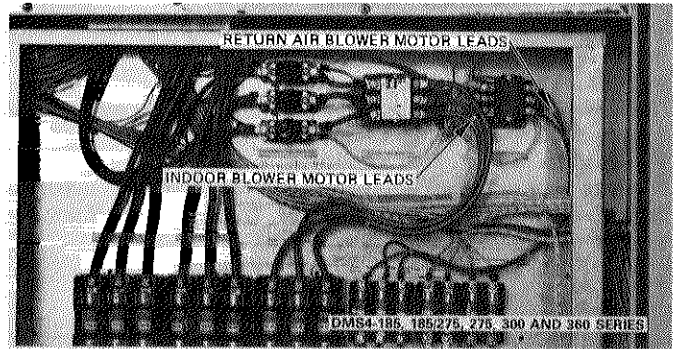

FIGURE 88



FIGURE 89

- 5 - Check amperage draw on each of the (3) wiring leads to the motor. See Figure 88 (185, 275, 300, 360 units) or Figure 89 (415, 600 units).
- 6 - Refer to Table 17 for motor full load amps.
- 7 - If amperage reading is greater than shown on Table 17, motor is overloaded. Overloaded motors must be replaced with a larger motor that will operate in the specified amperage range.

TABLE 17

| BLOWER MOTOR FULL LOAD AMPS (NEC) | | | | |
|-----------------------------------|----------|----------|----------|----------|
| *Blower Motor | 208 Volt | 230 Volt | 460 Volt | 575 Volt |
| Indoor | Amps | Amps | Amps | Amps |
| 3 Hp | 10.6 | 9.6 | 4.8 | 3.9 |
| 5 Hp | 16.7 | 15.2 | 7.6 | 6.1 |
| 7-1/2 Hp | 24.2 | 22.0 | 11.0 | 9.0 |
| 10 Hp | 30.8 | 28.0 | 14.0 | 11.0 |
| 15 Hp | 46.2 | 42.0 | 21.0 | 17.0 |
| Return | | | | |
| 1-1/2 Hp | 5.7 | 5.2 | 2.6 | 2.1 |
| 3 Hp | 10.6 | 9.6 | 4.8 | 3.9 |
| 5 Hp | 16.7 | 15.2 | 7.6 | 6.1 |

*See manufacturers nameplate for maximum full load amps.

VI - EXTERNAL STATIC PRESSURE MEASUREMENTS

If desired, external static pressure can be taken as follows:

- 1 - Assemble a static pressure probe according to Figure 90.
- 2 - Take external static pressures at locations specified in Figure 91.

VII - AIR BALANCING

A - Supply And Return Air Blowers

The unit must be adjusted so both supply and return blowers have the same air handling capacities. This is very important in buildings that are exceptionally tight. See Figure 92 for three applications where blowers should be in balance.

On multiple unit installations, operation of other equipment can greatly effect the balancing procedure. During checkout of each unit, shut off other units.

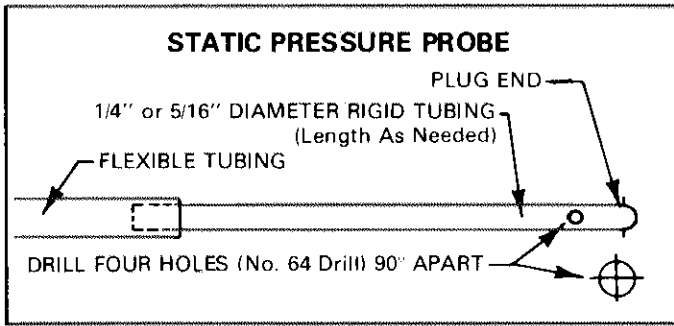

FIGURE 90

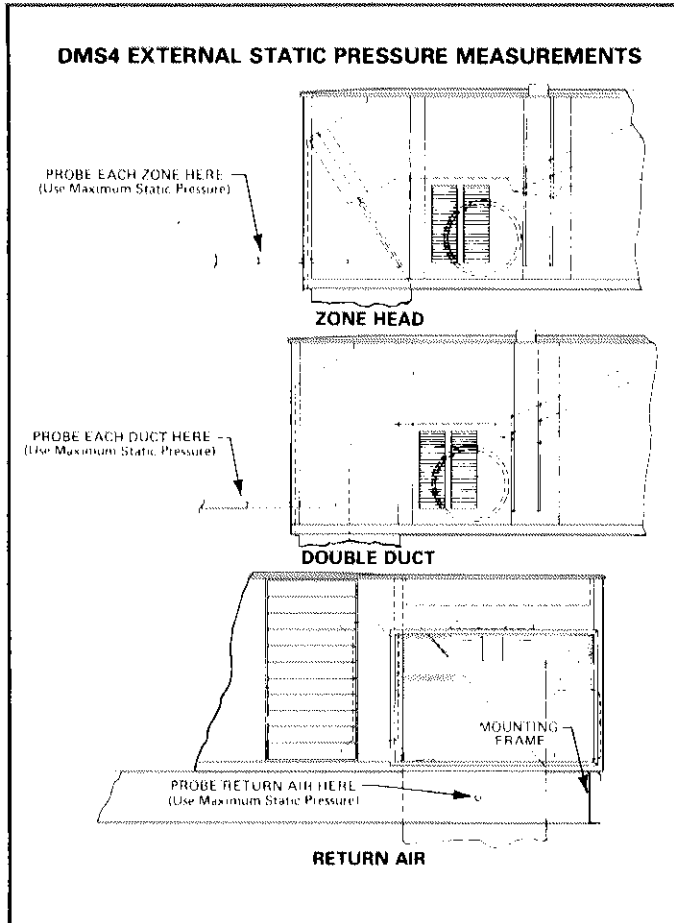

FIGURE 91

NOTE - When balancing unit, adjust zone dampers so that 50% of the air goes through hot deck and 50% goes through cold deck.

- 1 - Adjust main blowers, using watt meter or ammeter method to get desired operating cfm. This should be set with fresh air/return air dampers in the 50/50 position.
- 2 - Adjust fresh air/return air dampers to the 100% return air position and measure static pressure at position "A" on unit. See Figure 106. This static pressure must be 0" w.c. to + 0.10" w.c. (0 mm w.c. to 2.54 mm w.c.).
- 3 - If static pressure is negative at point "A", increase return air blower rpm until proper static pressure is obtained.

NOTE - Increasing or decreasing static pressure at point "A" will change overall pressure of indoor blowers and cfm accordingly. Therefore, some adjustment of indoor blowers rpm may be necessary.

4 - Adjusting Damper Volume

Because the supply run lengths and air requirements do vary, balancing dampers are provided at each zone head outlet to permit manual air adjustment. Refer to Figure 107. The installer must furnish

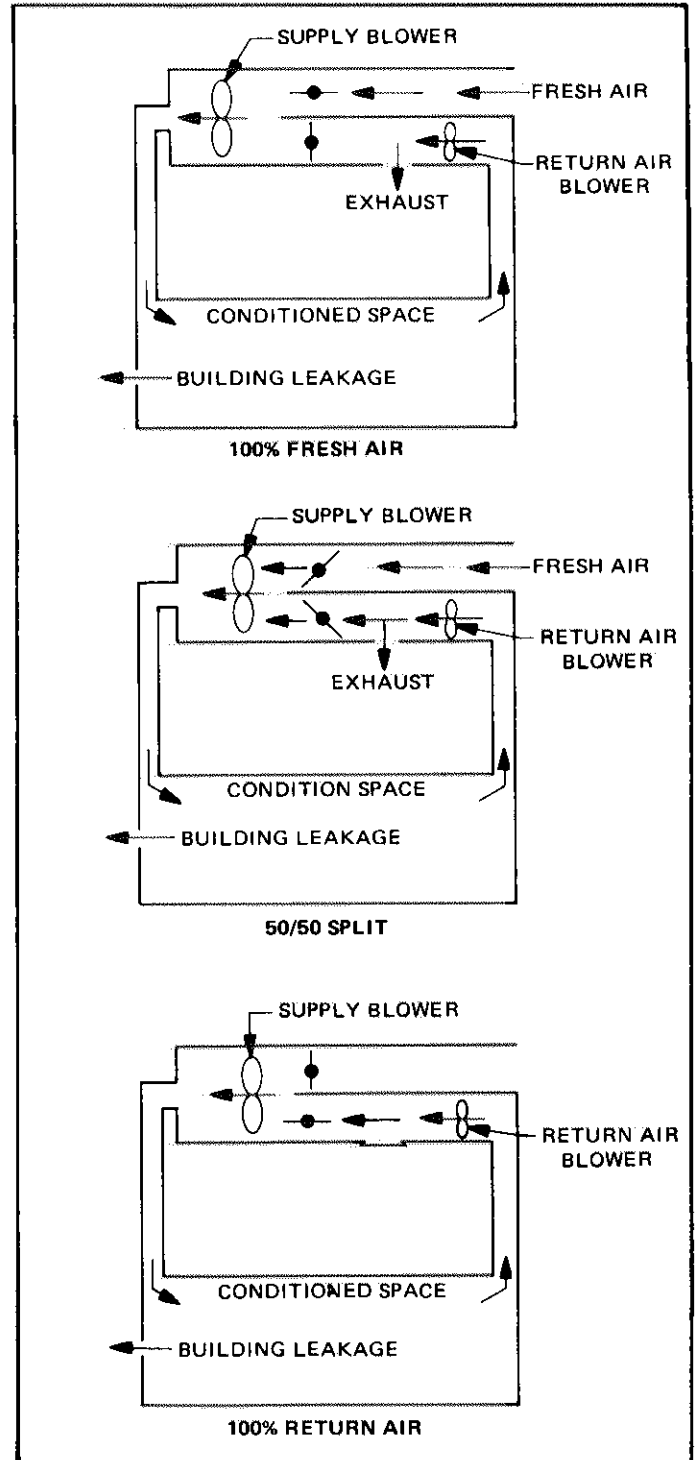

FIGURE 92

and install the balancing dampers for double duct applications. Dampers should be installed between the mixing box and diffuser outlet.

RVZ1 BLOWER SECTION

1 - BLOWER CONTROLS

The contactors, fusing and overloads for motors are identified within the disconnect box.

A - Blower Proving Switch

The blower proving switch senses an indoor blower motor failure and shuts down all systems within unit. See Figure 83.

BLOWERS

B - Firestats

Firestats (manual reset) are mounted in the return and supply air streams as shown in Figures 93 and 94. They will shut off unit with temperatures in excess of 136° F (57.8° C).

C - Night Blower Control (R1)

This control is only used on units equipped with night setback and smoke detectors. It runs the blower motor during night setback conditions so that the smoke detector system remains operable. The control is factory set to run at 50% of maximum blower speed. The control is adjustable to a minimum of 30% of maximum blower speed. Figures 46 and 47 on pages 47 and 48 identify the night blower control. If there is a heating demand during night setback, the blower motor speed is controlled by the A12 integrating analyzer. If the smoke detector alarm is activated R1 will switch the blower motor into night speed.

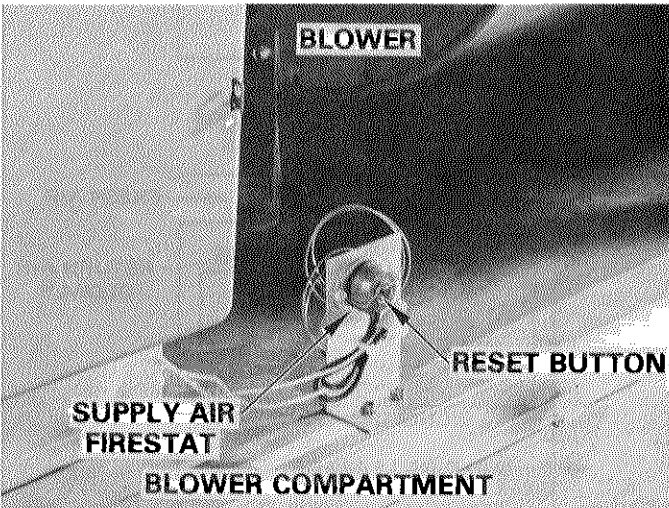

FIGURE 93

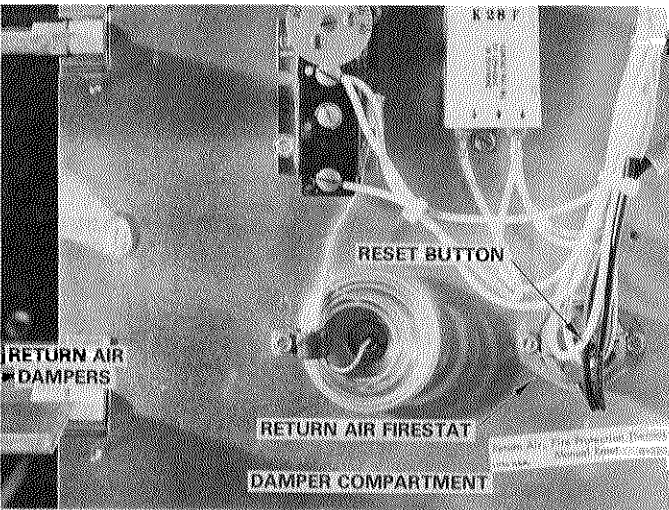

FIGURE 94

II - A12 INTEGRATING ANALYZER

A - Operation

The A12 integrating analyzer receives the zone signals from the room sensors. These signals range from 2 VDC to 22 VDC with 12 VDC as the balance point reflecting no demand. The A12 measures the difference between each zone signal and 12 VDC. It then takes an average of these differences to determine the new blower command signal. Chart C shows the correlation between the "average difference" and the blower command signal. This new signal is then transmitted to the inverter where it varies the blower motor RPM according to Chart D.

For example if there is an 11 zone unit with random zone command signals of 3, 6, 7, 8, 8, 12, 15, 17, 17, 19 and 20; the average signal

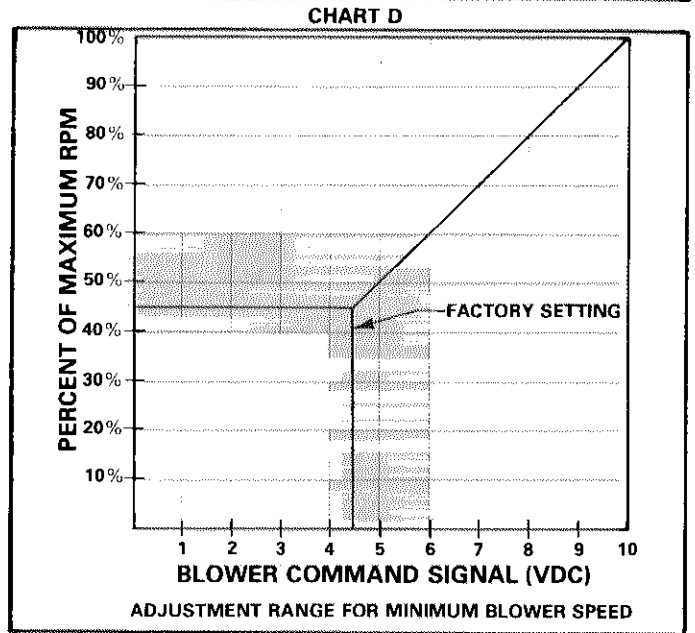
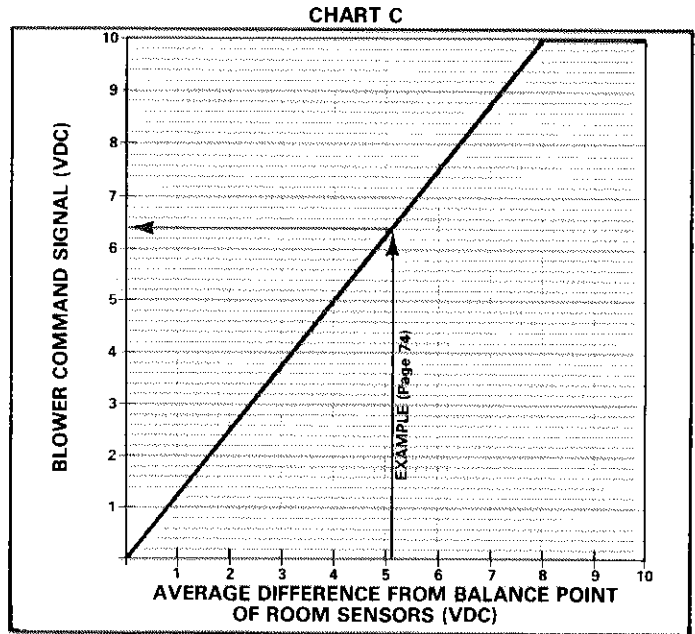

deviation is 5.1 and the blower command signal is 6.4 VDC. See Figure 95. The blower motor RPM will be approximately 64% of maximum speed.

The integrating analyzer has a minimum speed adjustment which puts a floor on the blower command signal and consequent motor speed. This adjustment is factory set at 4.5 VDC (blower command signal) or 45% of full air. The A12 can be field adjusted to transmit a minimum blower command signal ranging from 4 VDC to 6 VDC. This represents a minimum blower speed between 40% and 60% of the maximum RPM's.

B - Authority

Because the CFM requirements are greater on zones where two or more zone dampers are linked together, large zones must be given more authority over the control of blower speed. The A12 is factory jumpered so that each zone is given the correct proportion of authority in relation to its size.

The A12 has 12 terminals to receive the zone signals. On units with more than 12 zones, adder boxes are used to combine 2 or more signal together. This module is used for only the A9 Load Analyzer. Figure 96 illustrates a typical example of the authority given the A12.

EXAMPLE INVERTER COMMAND SIGNAL CALCULATION

| Zone Signals VDC | Signal Deviation From 12 VDC |
|---------------------------------------------------|---------------------------------|
| 3 | 9 |
| 6 | 6 |
| 7 | 5 |
| 8 | 4 |
| 8 | 4 |
| 12 | 0 |
| 15 | 3 |
| 17 | 5 |
| 17 | 5 |
| 19 | 7 |
| 20 | 8 |
| Total No. = 11 Signals | Total Deviation = 56 |
| $56 \div 11 =$ Average Signal Deviation = 5.1 VDC | |

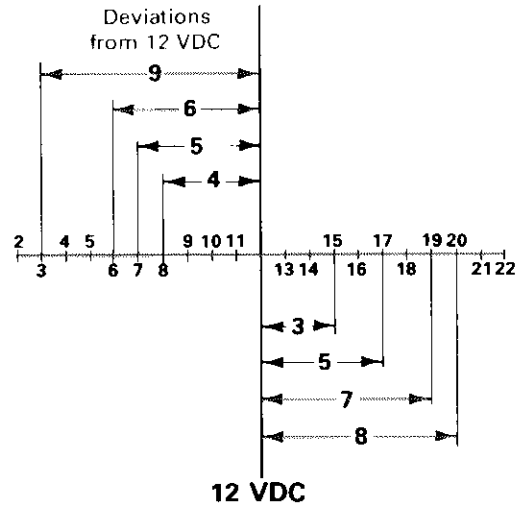

Average Signal Deviation = 6.4 Blower Command Signal
(ex. 5.1 VDC) Per Chart C

FIGURE 95

ILLUSTRATION OF INTEGRATING ANALYZER AUTHORITY FOR A TYPICAL 11 ZONE DAMPER HEAD

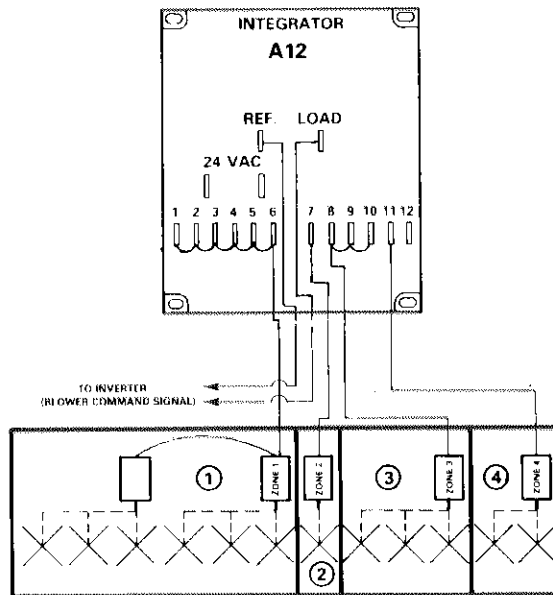

- 1 — Six zone openings mechanically and electrically slaved together. This zone has an authority of 6 at the A12.
- 2 — One zone opening with an authority of 1 at the A12
- 3 — Three zone openings mechanically slaved together. This zone has an authority of 3 at the A12.
- 4 — These two openings constitute one zone. This zone has an authority of 1 at the A12.

FIGURE 96

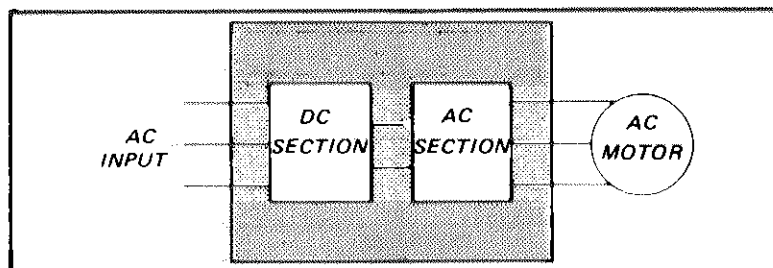

FIGURE 97

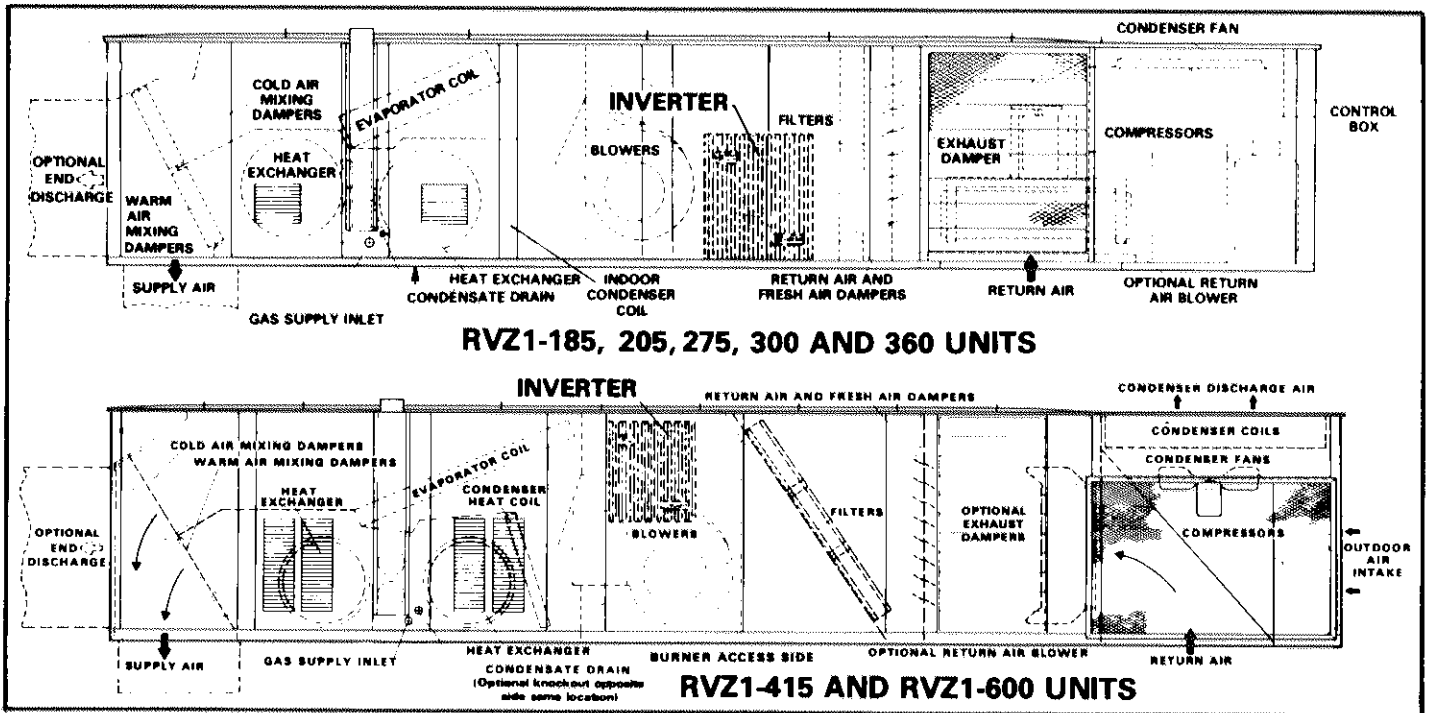

FIGURE 98

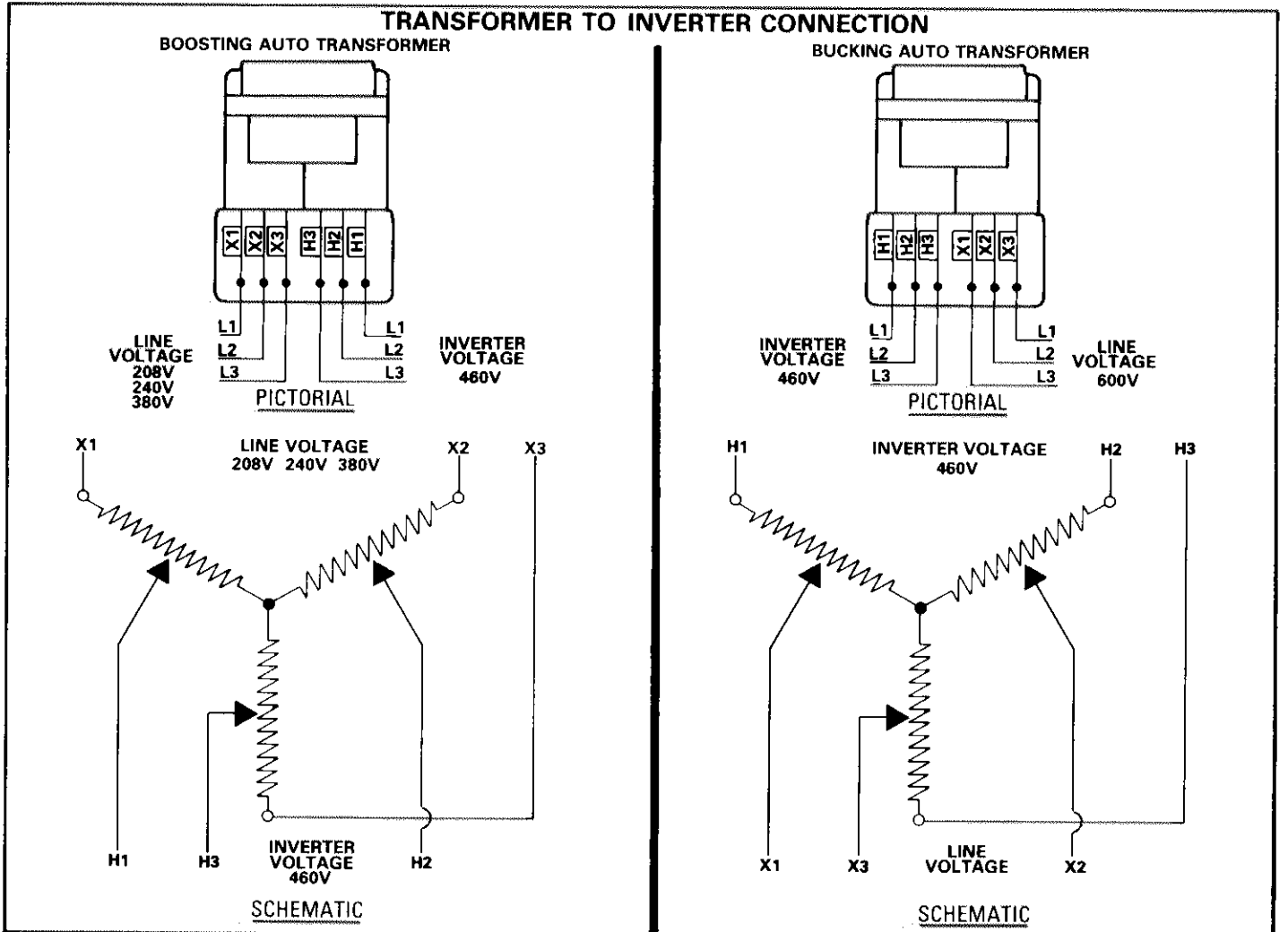

FIGURE 99

BLOWERS

III - INVERTER

A - Operation

The inverter accepts 460V line voltage and converts it to a variable voltage DC. The output of the DC stage is supplied to a 3 phase inverter which delivers adjustable frequency AC to the indoor blower motor and return blower motor (if used). See Figure 97. The speed of the motor is determined by the formula:

$$\text{Speed} = \frac{120 \times \text{frequency}}{\text{no. of poles}}$$

The blower command signal generated by the A12 integrating analyzer, determines the output frequency of the inverter. As the frequency varies, the motor(s) run faster or slower. Figure 98 shows location of inverter.

The inverter is protected by an internal overload to prevent overheating. If the inverter goes out on overload, it will automatically restart after a short time delay.

There is also an adjustment at the inverter which reduces the maximum frequency range from 60 hertz down to 48 hertz. The minimum setting is equivalent to an 8 volt blower command signal or 80% of maximum air. This adjustment is made if the motor(s) amperage exceeds its nameplate rating or if there is a need to adjust the blower speed less than 70 RPM. Refer to sections "VI - Determining

Indoor Blower Speed" and "VIII - Checking Indoor & Return Air Blower Motor Amperage".

B - Transformer

The incoming voltage to the inverter is 460V. Three phase auto transformers are utilized in applications where the power to unit is over 460V. Figure 99 illustrates the hookup for both buck and boost transformers.

C - Fusing

The size of the fusing which protects the inverter and blower motor(s) is dependent on the specific horsepower of the indoor blower motor and return blower motor. Refer to fuse replacement table on page 29.

V - BLOWER DRIVE SELECTION

Refer to Table 15 and Table 16 for maximum usable horsepower and drive selection for both the supply air blower and return air blower.

IMPORTANT

To check indoor blower CFM (m³/hr), indoor and return air blower motor amperage, external static pressure measurements, and air balancing, the zone dampers must be positioned so that 50% of the air goes through the hot deck and 50% goes through the cold deck. The blower motor must also be running at full demand. Turn one half of the room sensors to full heating and other other half to full cooling to meet these conditions.

TABLE 15

| SUPPLY AIR BLOWER | | | | | | | |
|-------------------|---------------------|-----------------------------------------|-----------------------------|-----------------------------|-----------------------------|-----------------------------|-----------------------------|
| Nominal Motor Hp | **Maximum Usable Hp | Rpm Range Of All Available Drive Setups | | | | | |
| | | 185, 275, 300 and 360 Units | | 415 and 600 Units | | | |
| | | @1725 Rpm Motor Speed/60 Hz | @1440 Rpm Motor Speed/50 Hz | @1725 Rpm Motor Speed/60 Hz | @3450 Rpm Motor Speed/60 Hz | @1440 Rpm Motor Speed/50 Hz | @2880 Rpm Motor Speed/50 Hz |
| 3 | 3.45 | 595/925 | 595/760 760/900 | --- | --- | --- | --- |
| 5 | 5.75 | 595/925 | 595/760 760/900 | 515/735 | --- | 512/650 595/735 | --- |
| 7-1/2 | 8.63 | 825/915 | 840/995 890/1070 | 680/900 | --- | 680/817 748/915 | --- |
| 10 | 11.50 | *960-1030- 1095-1160 | *990-1060- 1130-1200 | *725-780- 835-890 | --- | *720-775- 830-885 | --- |
| 15 | 17.25 | --- | --- | --- | *870-910- 950-1010 | --- | *825-970 |

*Fixed sheaves.

**On 50 Hertz units, nominal motor H.P. is the maximum usable H.P.

TABLE 16

| RETURN AIR BLOWER | | | | | |
|-------------------|--------------------|-----------------------------------------|-----------------------------|-----------------------------|-----------------------------|
| Nominal Motor Hp | *Maximum Usable Hp | Rpm Range of All Available Drive Setups | | | |
| | | 185, 275, 300 and 360 Units | | 415 and 600 Units | |
| | | @1725 Rpm Motor Speed/60 Hz | @1440 Rpm Motor Speed/50 Hz | @1725 Rpm Motor Speed/60 Hz | @1440 Rpm Motor Speed/50 Hz |
| 1-1/2 | 1.72 | 351/447 | 314/430 | 330/430 | 330/466 |
| 3 | 3.45 | 460/561 | 430/546 | 445/545 | 466/604 |
| 5 | 5.75 | 466/561 | --- | 550/665 | 568/700 |
| 7-1/2 | 8.62 | --- | --- | 680/815 | 660/817 |

*On 50 Hertz units, nominal motor H.P. is the maximum usable H.P.

IV - CHECKING INDOOR BLOWER CFM (m³/hr)

Either an amp or watt method can be used to determine indoor blower CFM (m³/hr).

A - Amp Method

Three factors are needed to determine indoor blower CFM (m³/hr); (1) measured blower RPM, (2) blower motor amps and (3) motor manufacturer HP.

1 - Using blower motor amperage, refer to correct Amps to Horsepower Curve on page 89, 90 or 91 to convert to HP.

2 - Using this HP figure, refer to curve on page 92 or 93 to convert HP and RPM to CFM (m³/hr.)

Example - Readings with a 15 HP, 460 volt rated General Electric Motor. 19 Amps 1,000 measured blower RPM

3 - Curve on page 91 — 19 Amps = 14 HP

4 - Curve on page 93 — 14 HP and 1,000 RPM = 15,300 CFM (25 998) m³/hr.

B - Watt Method (Preferred Method)

Two measured factors are needed in determining indoor blower CFM (m³/hr); (1) blower motor watts and (2) blower RPM.

NOTE - Motor watts must be determined with a watt-hour meter (watt meter).

1 - Using blower wattage read at motor, refer to curve on page 94 to convert watts to HP.

2 - Using this HP rating, refer to curve on page 92 or 93 to convert HP and RPM to CFM (m³/hr).

Example - Readings at unit

12,200 measured blower motor watts
1,000 measured blower RPM

3 - Curve on page 94 — 12,200 watts = 14 HP.

4 - Curve on page 93 — 14 HP and 1,000 RPM = 15,300 CFM (25 998 m³/hr).

VI - DETERMINING INDOOR BLOWER SPEED

1 - To determine desired indoor blower speed, the actual blower CFM (m³/hr) and blower RPM must be found as shown in section "IV" - Checking Indoor Blower CFM (m³/hr).

These factors plus the specified indoor blower CFM (m³/hr) can be made into a formula to calculate correct blower speed.

Example - 14,900 measured indoor blower CFM (25 318 m³/hr) at 800 blower RPM.

$$\frac{14,000 \text{ specified indoor blower CFM (23 788 m}^3\text{/hr).}}{14,900 \text{ CFM}} = 750 \text{ RPM}$$

$$\frac{23\ 788 \text{ m}^3\text{/hr} \times 800 \text{ REV/MIN}}{25\ 318 \text{ m}^3\text{/hr}} = 750 \text{ REV/MIN}$$

2 - On adjustments greater than 70 RPM's, either adjust sheave as shown in Figure100(below 10 HP) or change sheaves (10 HP and above). On adjustments less than 70 RPM's, use the inverter adjustment to lower the RPM's.

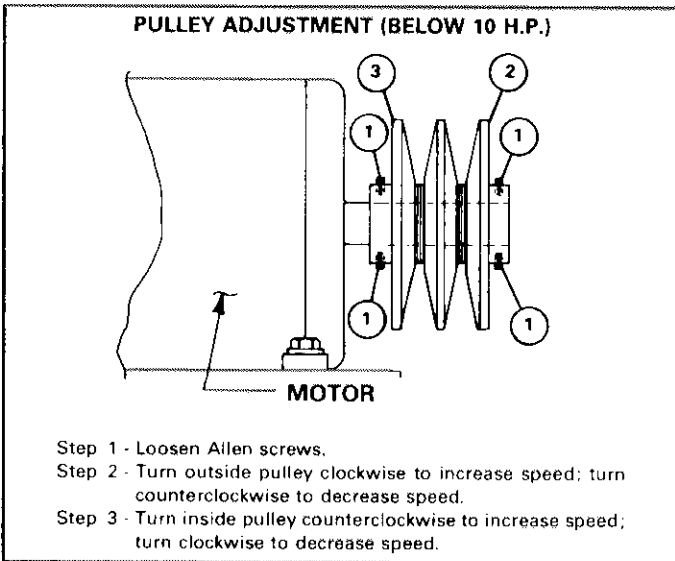

FIGURE 100

VII - CHECKING INDOOR AND RETURN AIR BLOWER MOTOR AMPERAGE

It is mandatory that the blower motor amperages be checked on every RVZ1 unit to be sure that the motor(s) are not overloaded. Should the motor(s) be overloaded, the inverter has an adjustment to lower the blower command signal which in turn lowers the

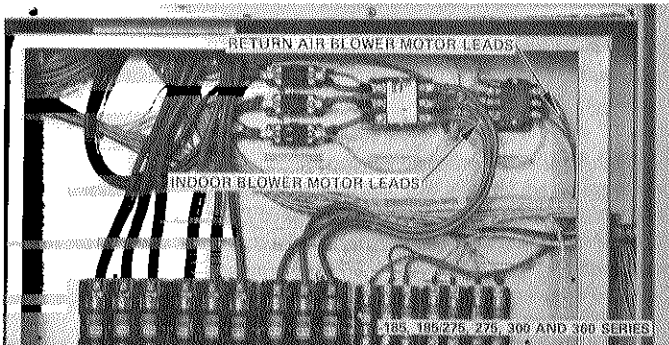

FIGURE 101

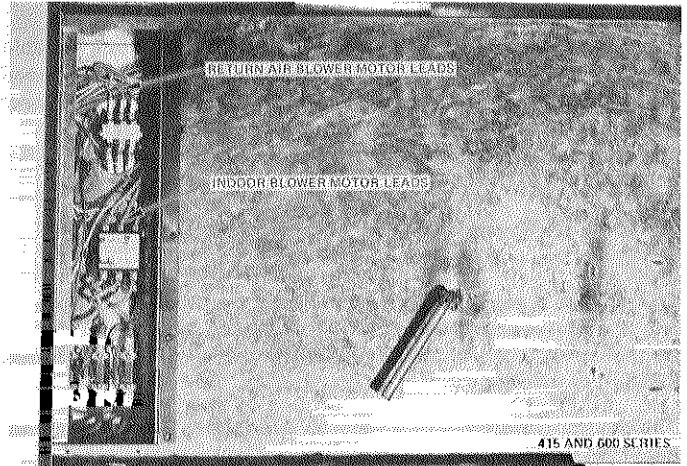

FIGURE 102

maximum RPM and consequent amperage. 8 volts is the minimum setting of inverter.

- 1 - Open exterior panel exposing the electrical box.
- 2 - Turn handle to open electrical box. This disconnects power to the unit.

WARNING - Box contains high voltage – use extreme caution.

- 3 - 415 and 600 Units Only - Remove indoor and return air blower motor contactor access panel. Refer to Figure101.
- 4 - Attach amp meter and then turn "On" disconnect.
- 5 - Check amperage draw on each of the (3) wiring leads to the motor. See Figure 95 (185, 275, 300, 360 units) or Figure101 (415,600 units).
- 6 - Refer to Table 17 for motor full load amps.
- 7 - If amperage reading is greater than shown on Table 17, the motor is overloaded. The inverter has a maximum speed adjustment which puts a ceiling to motor output. Turn the adjustment to lower amperage reading. Recheck amperage draw until the reading is acceptable.

IMPORTANT - The inverter is sized according to the horsepower of indoor and return air blower motors. Do not install larger motors without installing the correct size inverter.

TABLE 17

| HP | BLOWER MOTOR FULL LOAD AMPS (NEC) | | | | | | | |
|------|-----------------------------------|-----|------|----|---------------|----|-----|-----|
| | *SUPPLY MOTOR | | | | *RETURN MOTOR | | | |
| | 3 | 5 | 7½ | 10 | 15 | 1½ | 3 | 5 |
| AMPS | 5.5 | 8.7 | 12.6 | 16 | 24 | 3 | 5.5 | 8.7 |

*See manufacturers nameplate for maximum full load amps.

VIII - EXTERNAL STATIC PRESSURE MEASUREMENTS

If desired, external static pressure can be taken as follows:

- 1 - Assemble a static pressure probe according to Figure103.
- 2 - Take external static pressures at locations specified in Figure104.

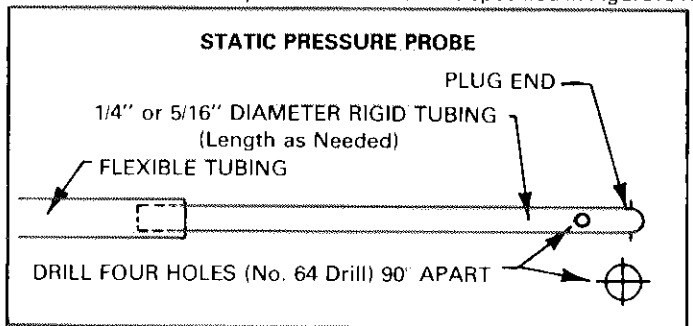

FIGURE 103

IX - AIR BALANCING

A - Supply And Return Air Blowers

The unit must be adjusted so both supply and return blowers have

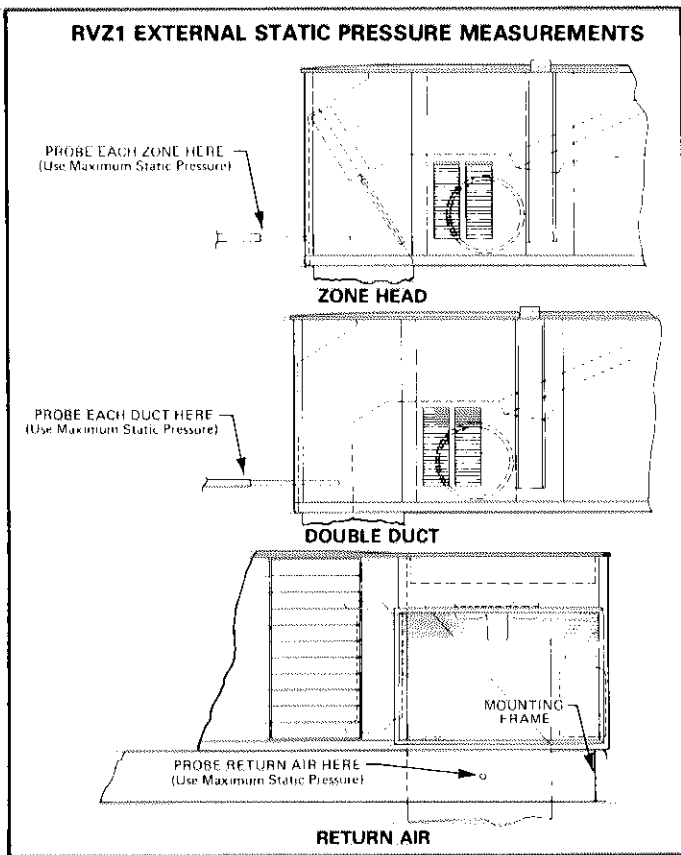

FIGURE 104

the same air handling capacities. This is very important in buildings that are exceptionally tight. See Figure 105 for three applications where blowers should be in balance.

On multiple unit installations, operation of other equipment can greatly effect the balancing procedure. During checkout of each unit, shut off other units.

- 1 - Adjust main blowers, using watt meter or ammeter method to get desired operating cfm. This should be set with fresh air/return air dampers in the 50/50 position.
- 2 - Adjust fresh air/return air dampers to the 100% return air position and measure static pressure at position "A" on unit. See Figure 106. This static pressure must be 0" w.c. to + 0.10" w.c. (0 mm w.c. to 2.54 mm w.c.).
- 3 - If static pressure is negative at point "A", increase return air blower rpm until proper static pressure is obtained.

B - Adjusting Damper Volume

Because the supply run lengths and air requirements do vary, balancing dampers are provided at each zone head outlet to permit manual air adjustment. Refer to Figure 107. The installer must furnish and install the balancing dampers for double duct applications. Dampers should be installed between the mixing box and diffuser outlet.

RVZ1 AND DMS4

I - DMS4 AND RVZ1 BELT ADJUSTMENT

Maximum life and wear can be obtained from belts only if proper pulley alignment and belt tension are maintained.

Initially, tension new belt(s) at the maximum deflection force recommended: then re-tension belt(s) after a run in period of 24-48 hours. This allows belt(s) to stretch and seat in the grooves.

A - Pointers For Installing Belts

- 1 - Use a matched set of belts.
- 2 - Clean oil and grease from the grooves, also remove any rust or burrs from the sheave grooves.
- 3 - Shorten the center distance of the drive until the belts can be put on the sheaves without forcing.

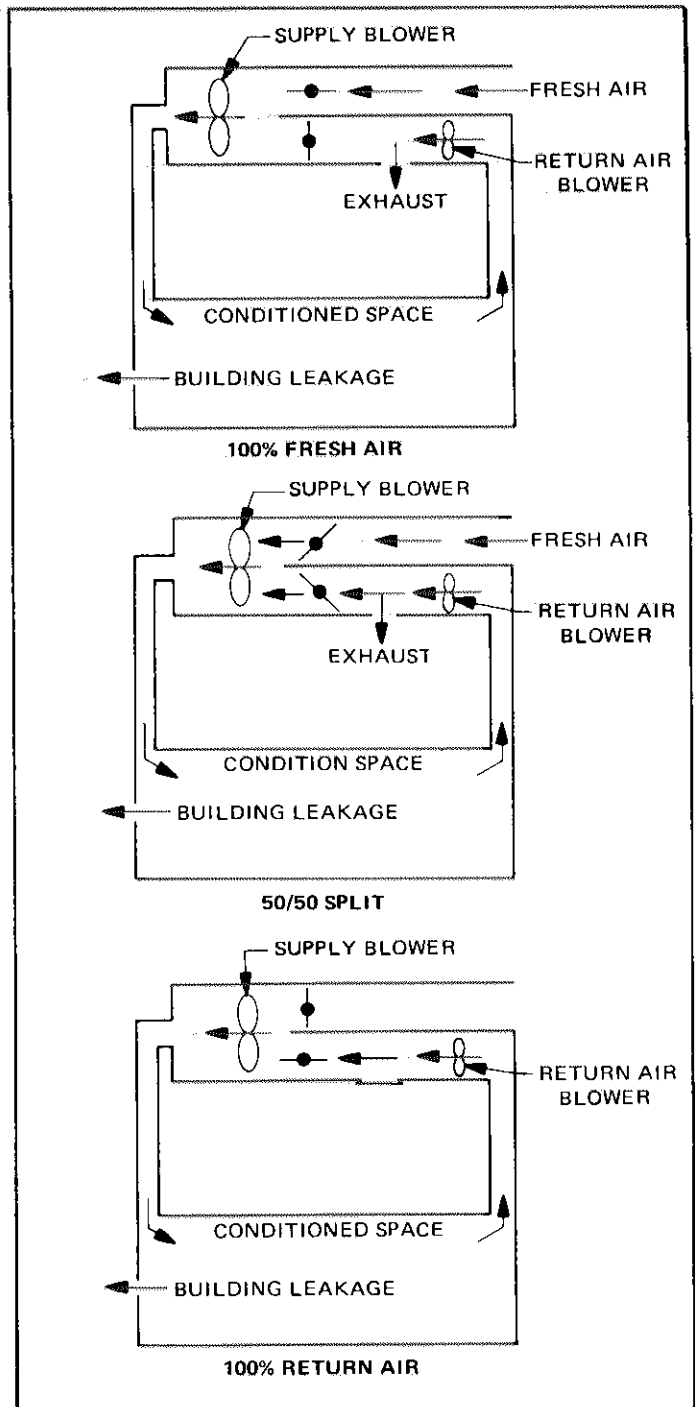

FIGURE 105

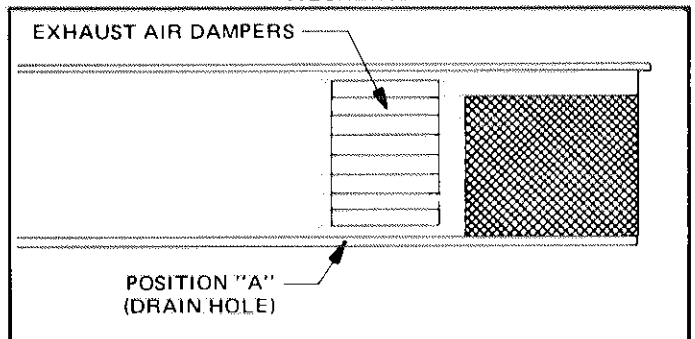

FIGURE 106

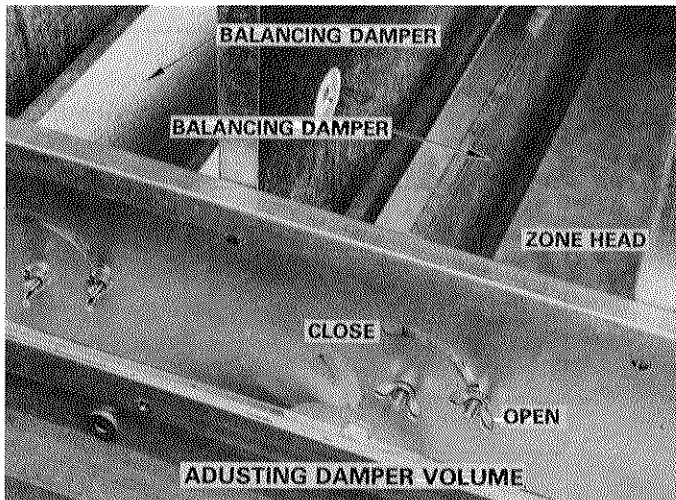

FIGURE 107

4 - Make sure that the sheaves are correctly aligned, the shafts are parallel, there is clearance for the drive to run and the bearings have oil.

5 - On two groove adjustable pulley, be sure both are set at same pitch diameter.

B - Tensioning Belts

Ideal tension is the lowest tension at which the belt(s) will not slip under peak load conditions. Over-tensioning shortens belt and bearing life. The following is a recommended procedure for tensioning belts.

1 - Measure the span length, X. Refer to Figure 108.

2 - At center of span length (X) apply a force perpendicular to span large enough to deflect belt 1/64" for every inch of span length (deflection 1.5 mm per 100 mm of span length).

Example - Deflection force of a 40" span would be 40/64 or 5/8".

Example - Deflection force of a 1000 mm span would be 15 mm.

3 - Compare the applied force with the value given in Table 18. If the

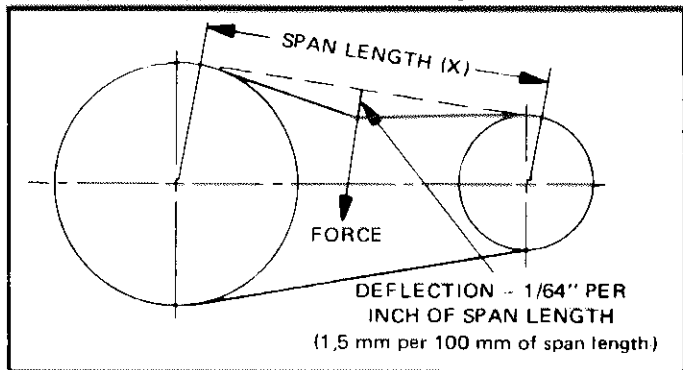

FIGURE 108

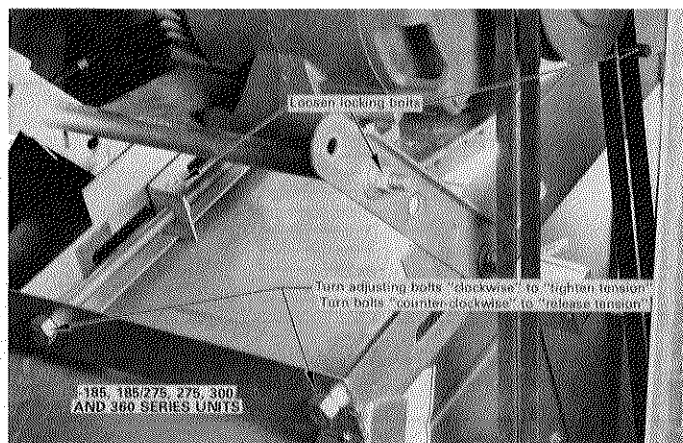

FIGURE 109

force is between the minimum and maximum range shown, the drive tension should be satisfactory. A force below minimum value indicates an undertensioned belt. A force that exceeds maximum value indicates an overtensioned belt. Adjust the belt tension for the indoor blower as shown in Figures 109 and 110. Adjust the belt tension for the return blower as shown in Figures 111 and 112.

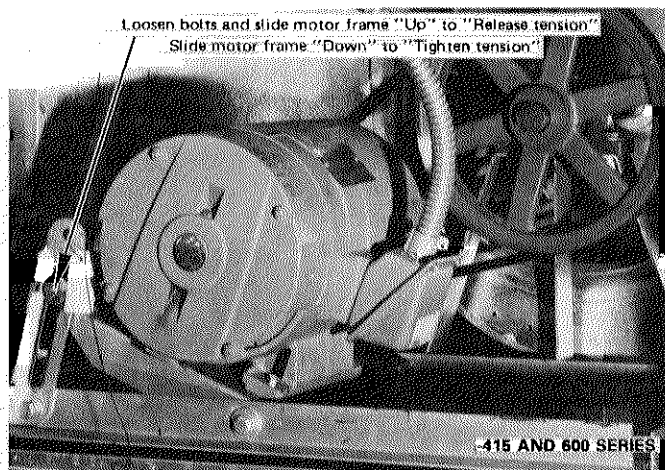

FIGURE 110

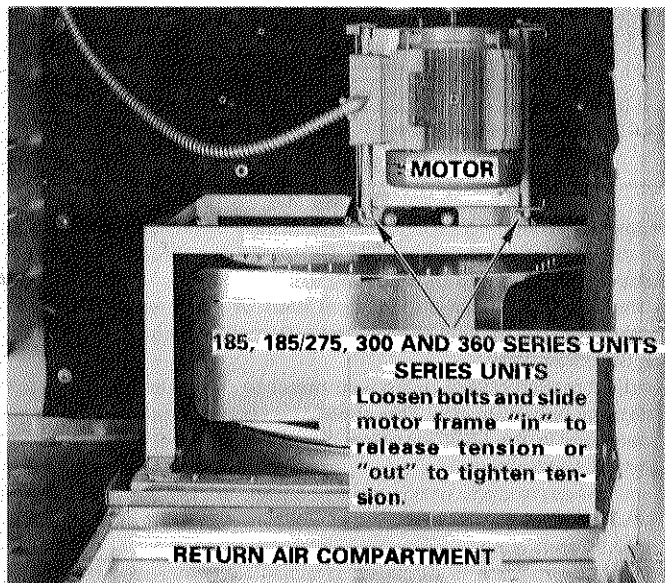

FIGURE 111

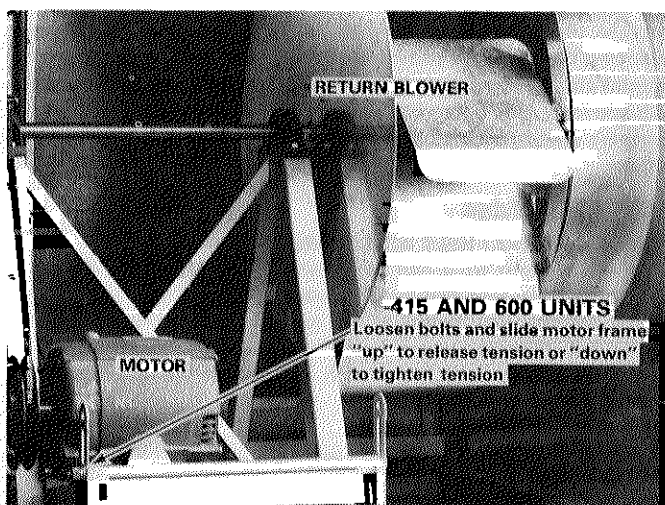

FIGURE 112

TABLE 18

| Belt Cross Section (Marked on Belt) | Motor Pulley Pitch Diameter | | Deflection Force | | | |
|----------------------------------------|-----------------------------|---------------|------------------|------|---------|------|
| | in. | mm | Minimum | | Maximum | |
| | | | lbs. | Kg | lbs. | Kg |
| A | 3.0 — 3.6 | 76,2 — 91,4 | 2-5/8 | 1,19 | 3-1/4 | 1,47 |
| | 3.8 — 4.8 | 96,5 — 121,9 | 3 | 1,36 | 4 | 1,81 |
| | 5.0 — 7.0 | 127,0 — 177,8 | 3-1/4 | 1,47 | 5 | 2,27 |
| B | 3.4 — 4.2 | 86,3 — 106,6 | 3 | 1,36 | 5 | 2,27 |
| | 4.4 — 5.6 | 111,7 — 142,2 | 4 | 1,81 | 5-7/8 | 2,66 |
| | 5.8 — 8.6 | 147,7 — 218,4 | 5-1/4 | 2,38 | 7-7/8 | 3,57 |

II - DMS4 AND RVZ1 LUBRICATION

A - Motor Bearings

NOTE - Always relubricate motors according to manufacturer's lubrication instructions on each motor. If no instructions are provided, use the following as a guide:

- 1 - *Indoor and Return Air Blower Motor Bearings* - Bearings are pre-lubricated. For extended bearing life, relubricate at least once every two years with a lithium base grease, such as Westinghouse 5370RW, Chevron BRB2 (Standard Oil) or Andok 260 (Exxon Oil). To relubricate, replace top plugs with standard grease fittings. Remove lower outlet plugs and add grease with handgun until new grease appears at bottom outlets. Run motor for a short time before replacing bottom plugs. Refer to Figures 83 and 84.
- 2 - *Condenser Fan Motors* - Pre-lubricated and sealed. No further lubrication required.

B - Blower Bearings

Indoor and Return Air Blower Bearings - Bearings are pre-lubricated. For extended bearing life, relubricate at least once every two years with a lithium base grease, such as Alvania 3 (Shell Oil), Chevron BRB2 (Standard Oil) or Regal AFB2 (Texas Oil). Use hand grease gun for relubrication. Add only enough grease to purge through the bearings so that a bead of grease appears at the seal lip contacts. Refer to Figures 83 and 84.

III - DMS4 AND RVZ1 BLOWER BEARING REPLACEMENT

A - Alignment of Blower Bearings

Before installing blower bearings, the self-alignment feature of the bearing must be loose and free. Use the following procedure.

- 1 - Hold bearing stationary, such as in a vice.
- 2 - Insert a short length of blower shafting or wooden mallet handle into bearing to serve as a lever. **Do not use a tool that will score or gouge the inside surface of the bearing.**
- 3 - Move lever side to side and up and down until bearing rotates free and easy in the housing. A small amount of light weight oil between the outer race and the bearing housing may aid in loosening the self-alignment feature.

IMPORTANT - If the self-alignment feature of the bearing can not be freed, do not use the bearing.

B - Assembly of Shaft, Bearings and Wheels

- 1 - Clean grease and dirt from blower shaft with solvent. **During assembly it is extremely important to keep shaft free of oil at the bearing locations since a bearing/shaft sealant will be used and oil will decrease the effectiveness of the sealant. However, a light coat of oil may be used on other areas of the shaft to aid in sliding shaft through blower wheels.**
- 2 - Assemble bearings, locking collars and blower wheels on the shaft.
- 3 - Proceed with securing bearing housings to frame. It is extremely important to properly align bearings to shaft. The bearing housing must be aligned so it will **rest perfectly flat** on the frame mounting arm. Tap lightly on the bearing housing with wooden mallet to obtain this alignment, then use slotted holes to center blower wheels in the housing orifice and secure bearing housings to frame.

IMPORTANT - There must be no misalignment between the bearing housing and frame since tightening down misaligned bearings will cause binding conditions and will result shortly in bearing and/or shaft failure.

- 4 - Now center the blower wheels side to side in housings and secure with woodruff keys and set screws.
- 5 - Check bearing and shaft alignment by sliding the shaft back and forth in the bearing. A properly aligned assembly should slide easily; not requiring over 40 lbs. (18 Kg) of force.

C - Bearing and Shaft Sealant

It is recommended that a sealant (loctite #601) be used between the bearing and shaft to take up clearance and aid in securing the inner race to the shaft. Loctite #601 is available from the Lennox Parts Center in 10 cc tubes, part number P-8-11211. An acceptable substitute is Stud, N Bearing Mount, Loctite #22, which is available at most automotive supply houses.

- 1 - Apply the sealant **springly** to the shaft on each side of the bearings. Slide the shaft back and forth until sealant is thoroughly worked into the shaft and bearing contact area.

NOTE - Loctite sealants remain liquid outside the joint. Remove excess. Sealant will partially cure in 10 minutes and fully cure in 1 hour.

D - Locking Collars

If "Schwezwloc" Sealmaster bearings are used, install locking collars immediately. Torque the set screws on collars by bending hex wrench. If bearings with eccentric locking collars are used, allow approximately 10 minutes for sealant to cure before locking collars in place. Lock as follows:

- 1 - Mate cam of collar with cam of bearing inner ring.
- 2 - Press collar lightly against inner ring, then turn collar **in direction of shaft rotation** until engaged. Refer to Figure 113.
- 3 - With draft pin in collar hole, strike in direction of shaft rotation to lock. See Figure 114.
- 4 - Tighten set screw in collar.

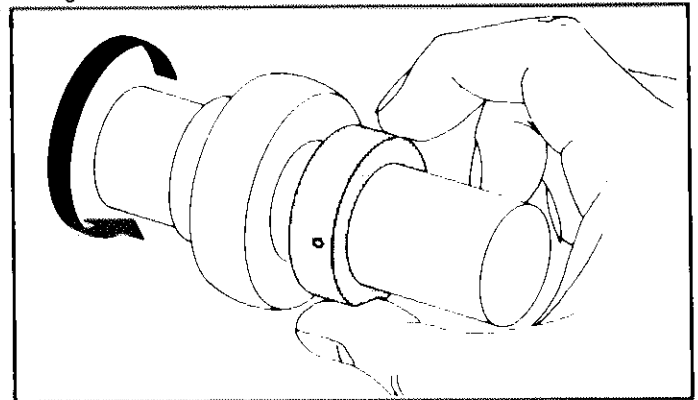

FIGURE 113

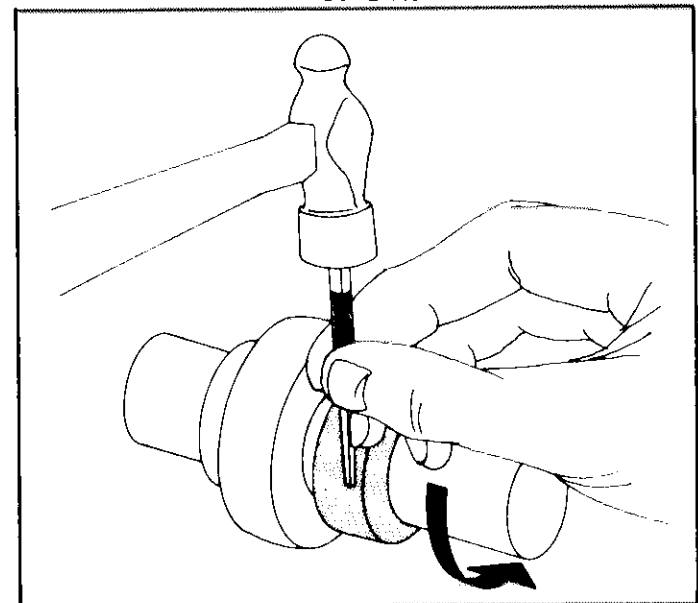
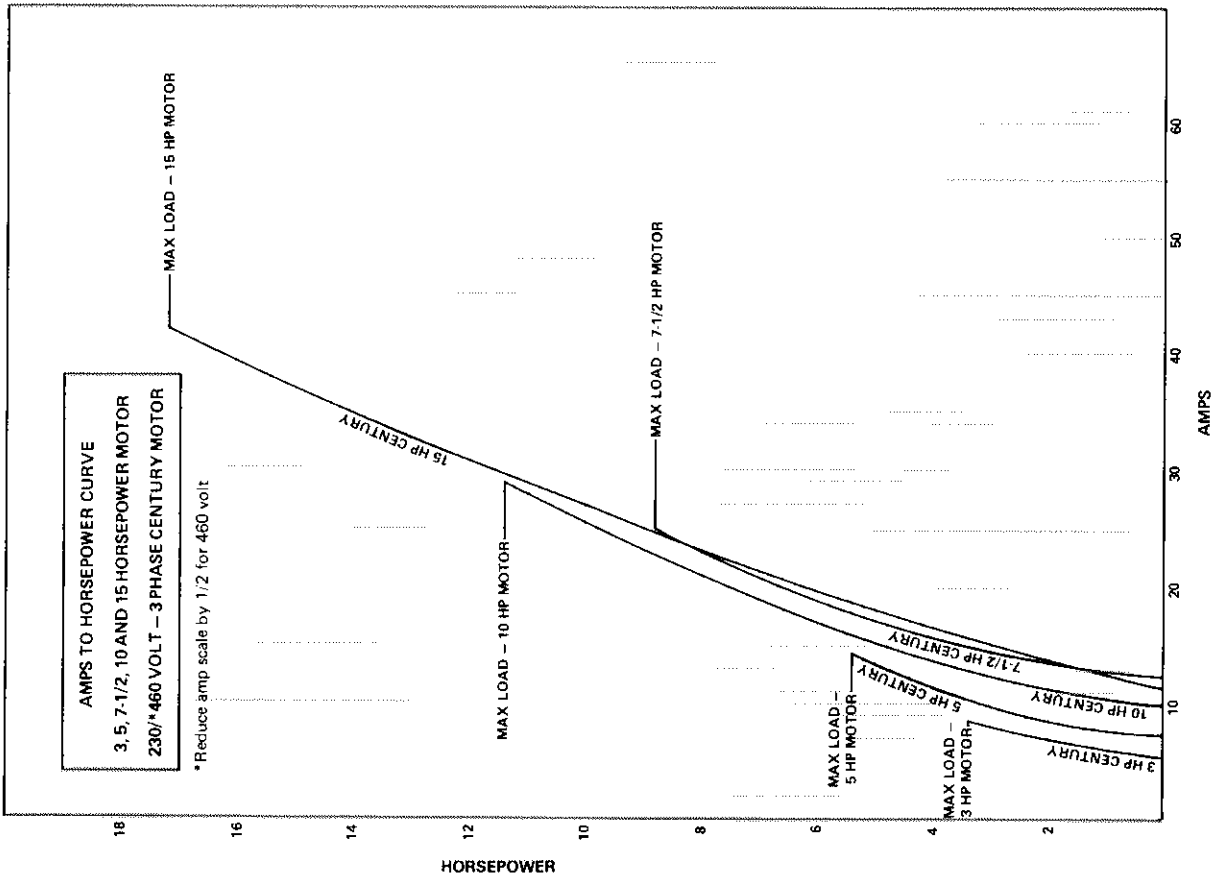
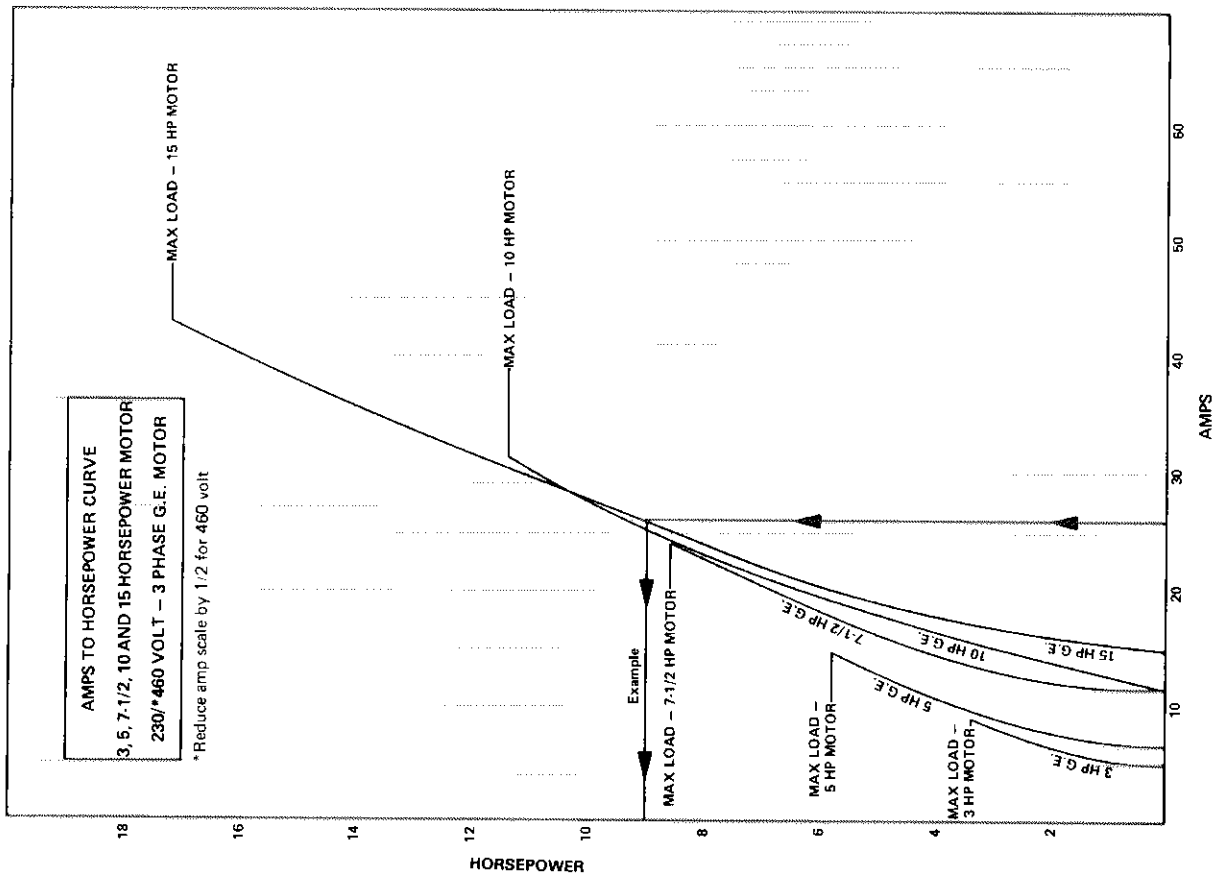
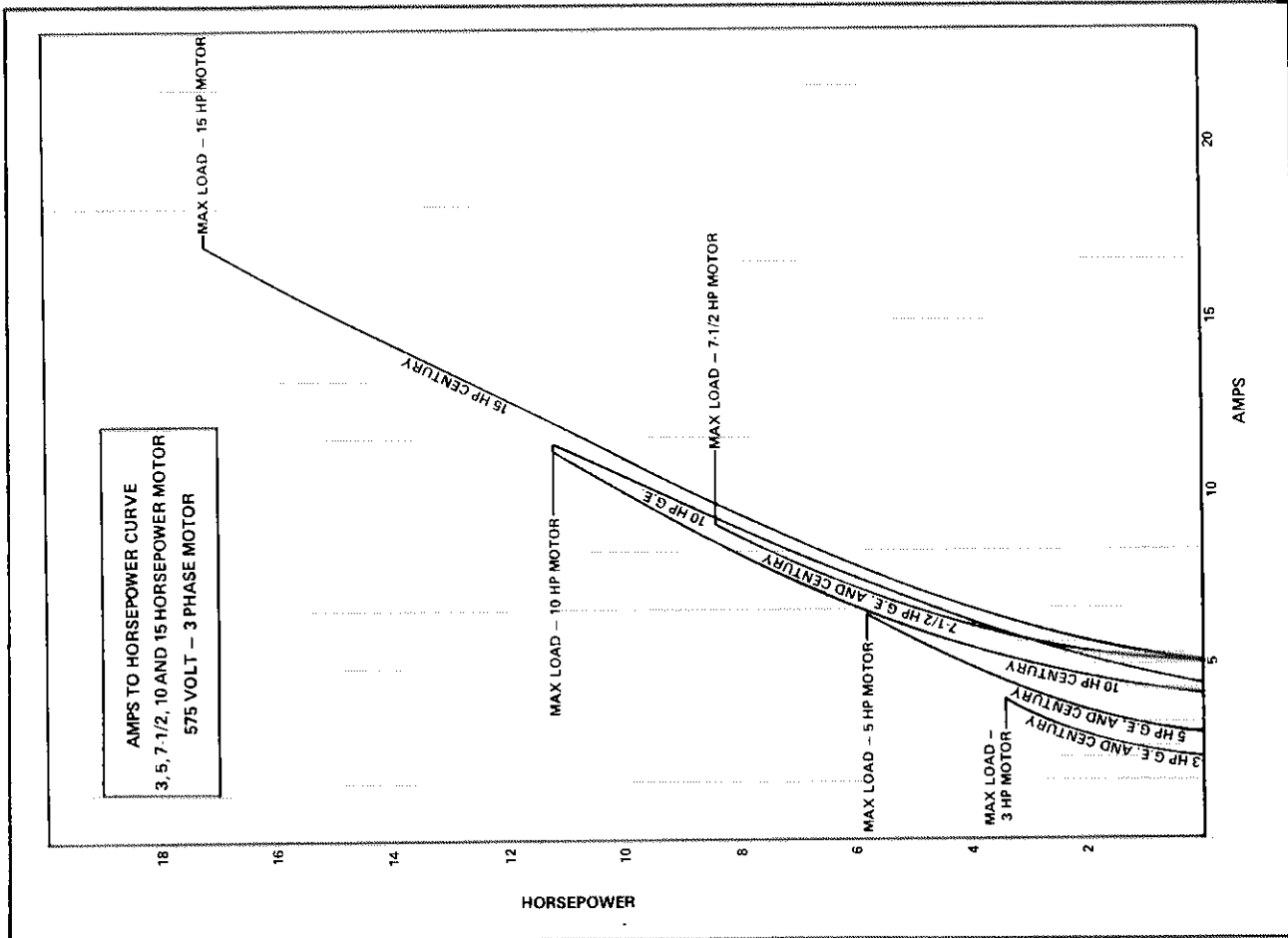
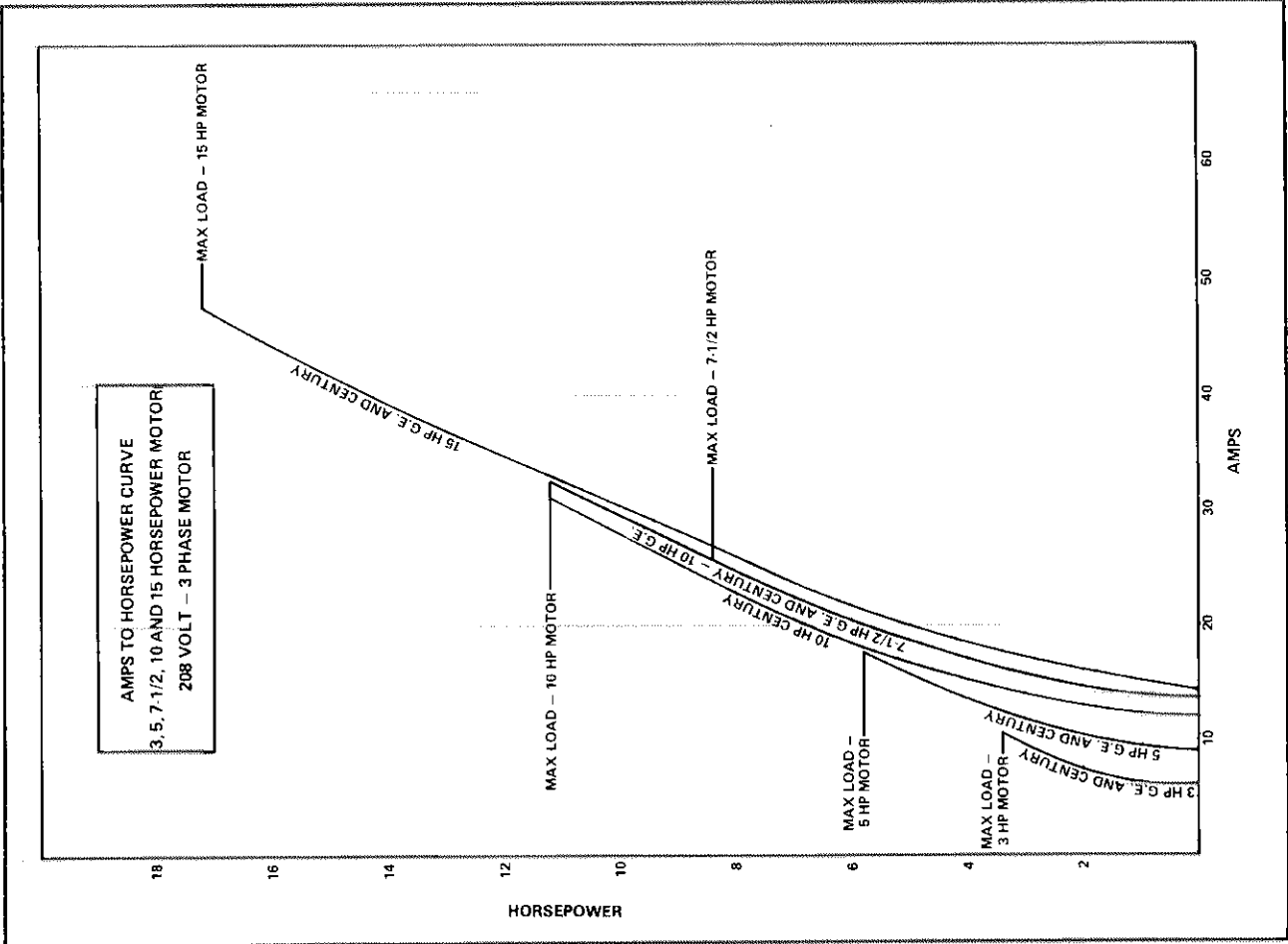
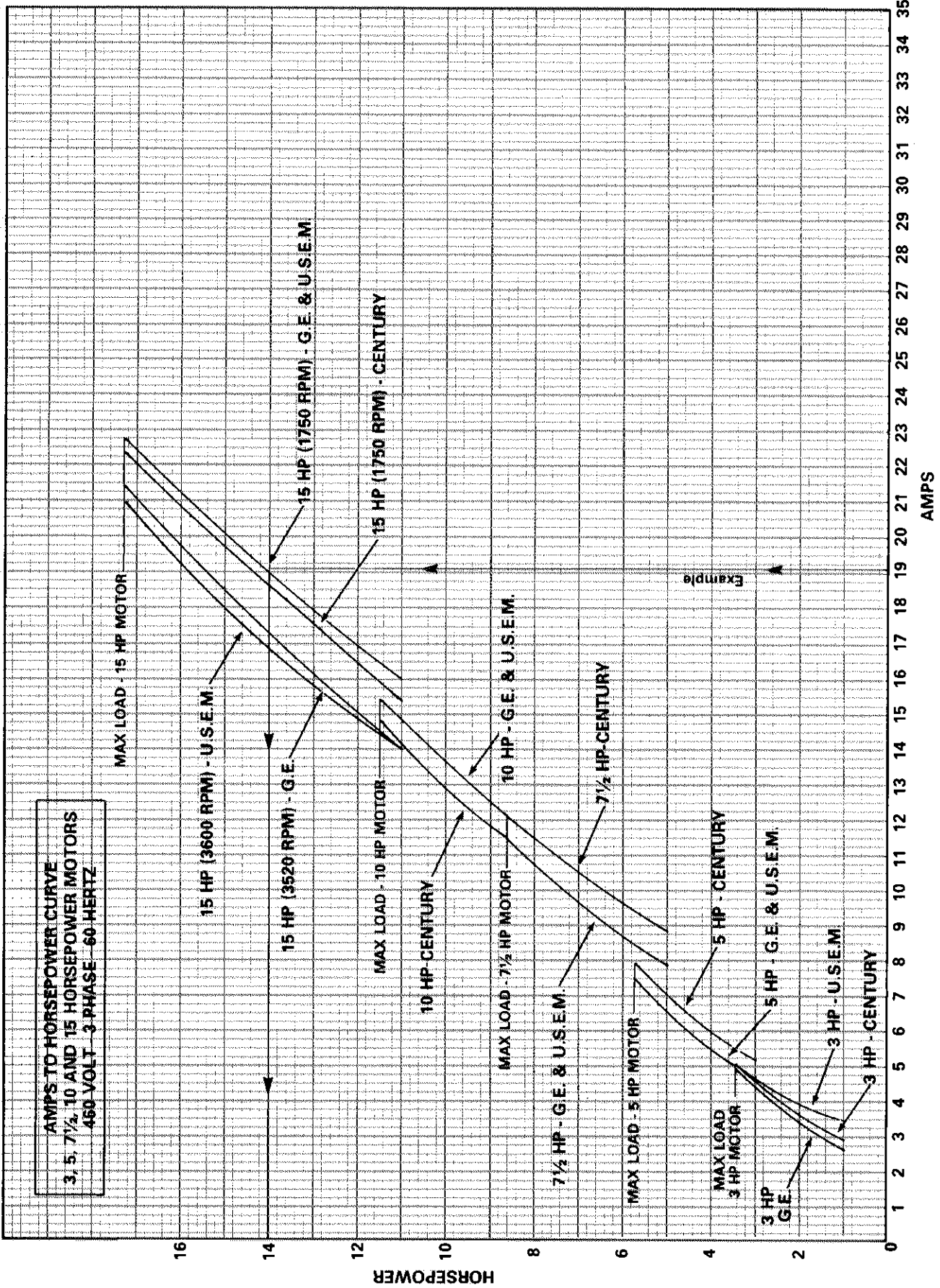

FIGURE 114







HORSEPOWER - RPM TO CFM CONVERSION CURVE
INDOOR BLOWER MOTOR
185, 275, 300 AND 360 SERIES UNITS

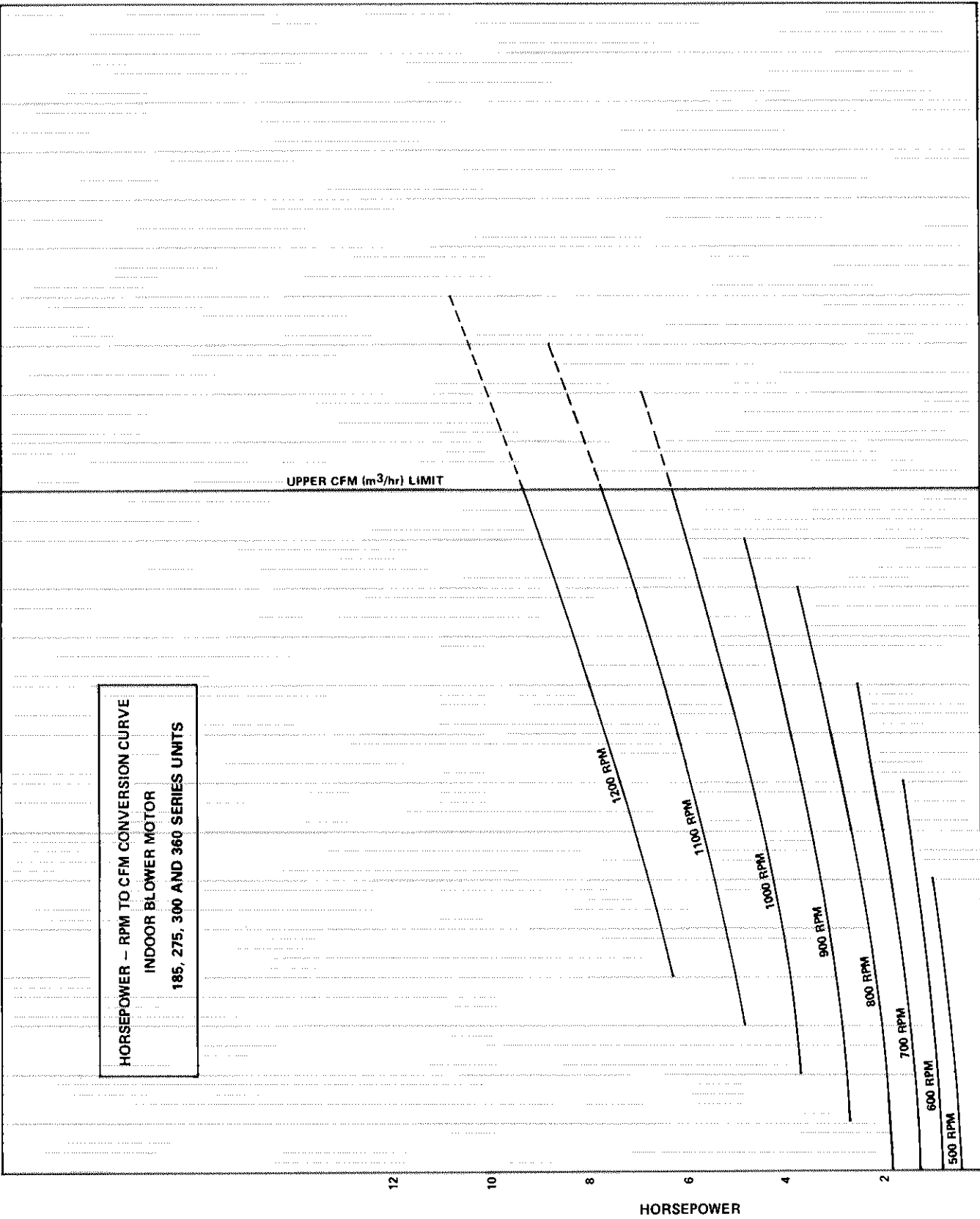

BLOWERS

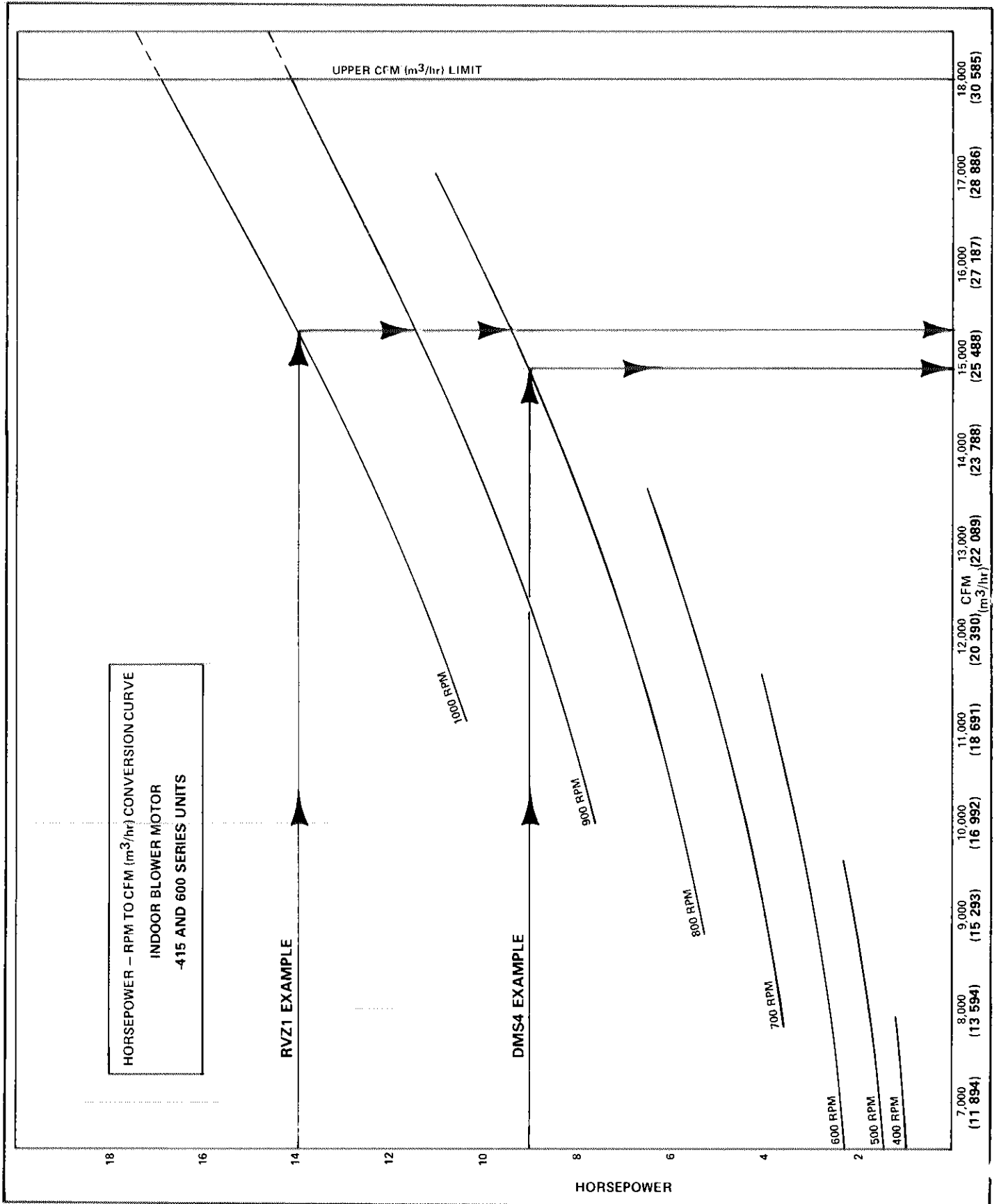

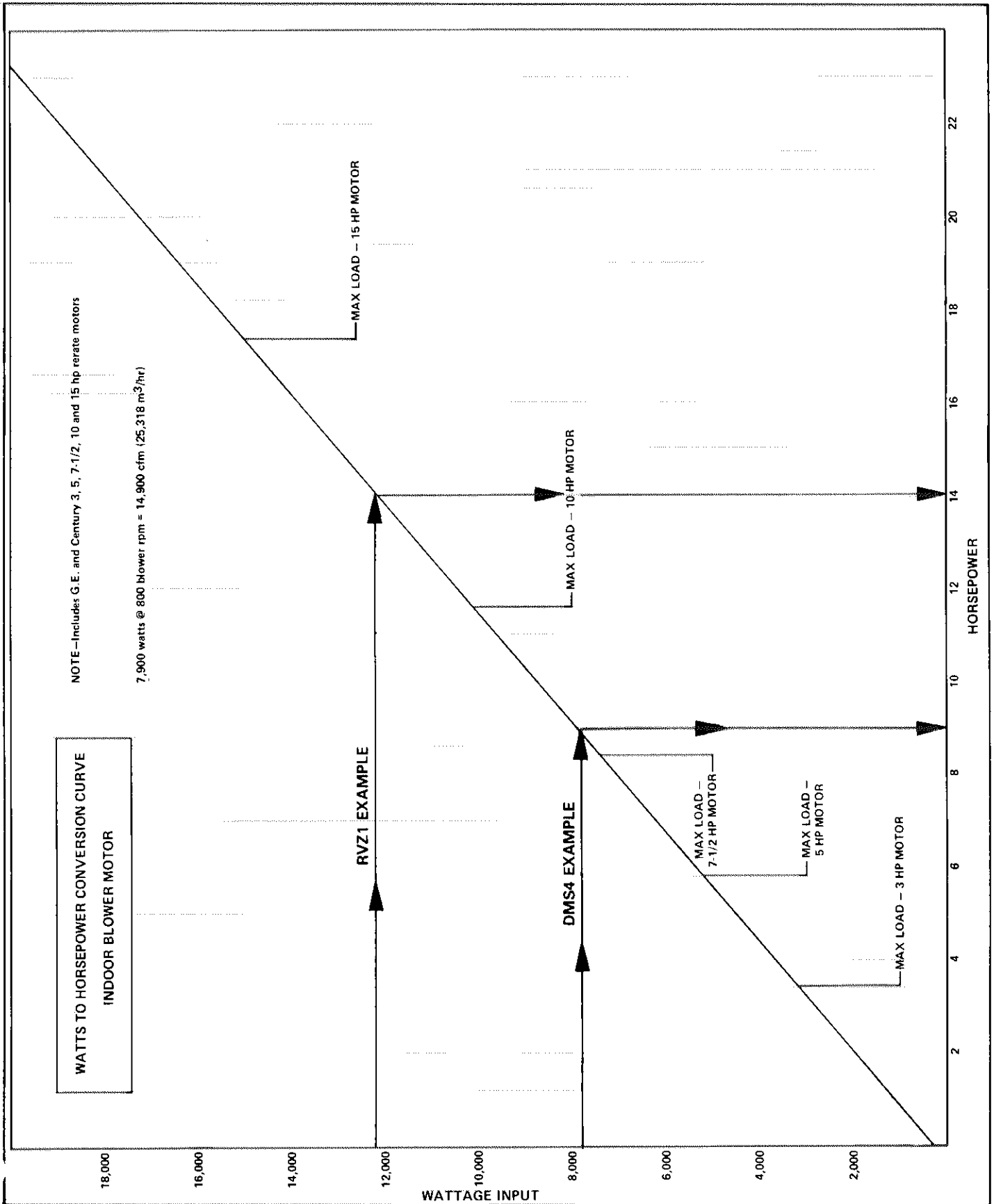

BLOWERS

ELECTRONIC ZONE CONTROL

1 - GENERAL

A - Dual Duct

ZD6 (DMS4) and ZD8 (RVZ1) mixing boxes are available for double duct applications. See Figure 115. The discharge sensor and zone damper actuator are located at mixing box. Refer to mixing box installation instructions.

B - Zone Dampers (Figure 116)

- 1 - *DMS4* - Hot and cold damper blades are mounted on a common shaft. Blades are always 90 degrees to each other. Vertical adjustment should allow blades to rotate freely without binding on ends or center divides.
- 2 - *RVZ1* - The RVZ1 zone dampers are designed so that the hot and cold damper blades operate independently. A magnetic/spring overdrive mechanism will allow one blade to remain closed or at minimum while the other is opening.

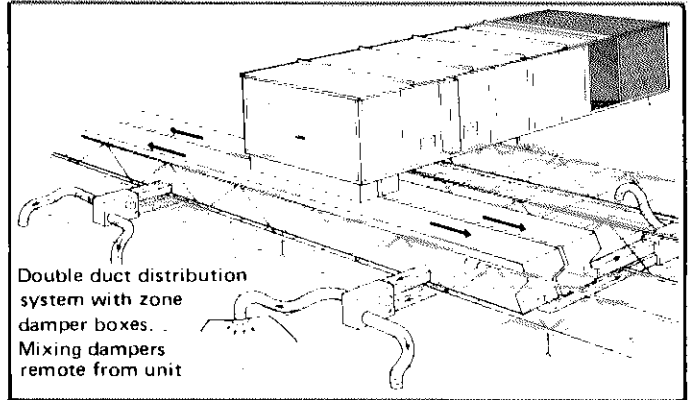
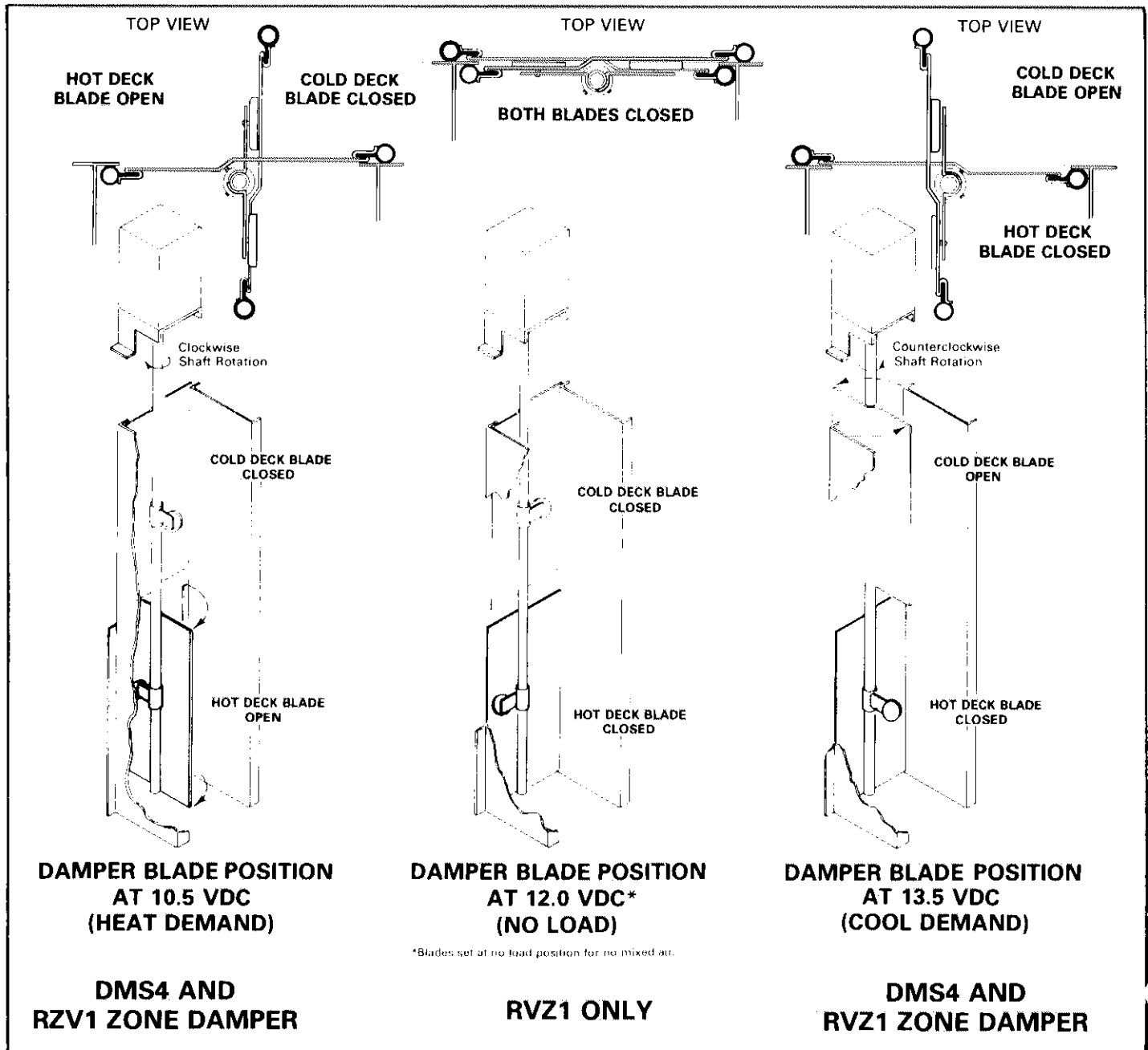

FIGURE 115



*Blades set at no load position for no mixed air.

FIGURE 116

II - ZONE DAMPER ACTUATOR

A - Actuator

At 10.5 VDC the zone damper is open to the hot deck and closed to the cold deck. At 13.5 VDC the zone damper is closed to the hot deck and open to the cold deck. On RVZ1 units only, both damper blades are closed or at minimum position at 12 VDC. Refer to Figure 116 for operation of the zone dampers.

B - Mechanically Slaving Dampers

One zone damper actuator can operate a series of damper blades by mechanically connecting zones to motor. Refer to Figure 117.

NOTE - Do not connect more than 3 blades per actuator for RVZ1 units or 4 blades per actuator for DMS4 units.

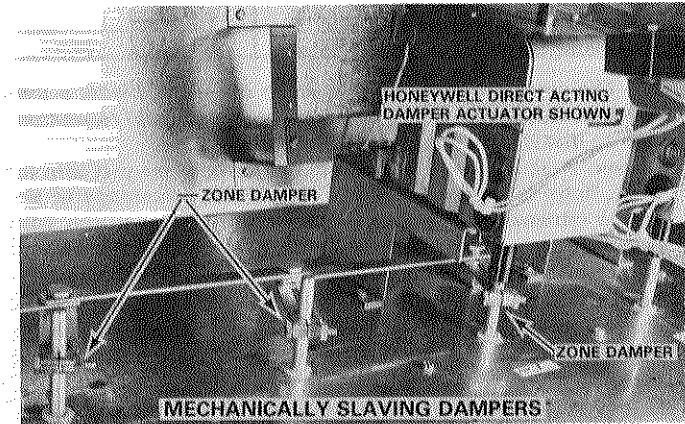

FIGURE 117

C - Electrically Slaving Actuators

- 1 - Connect terminal R of secondary motor to terminal R of primary motor.
- 2 - Connect terminal C of secondary motor to terminal C of primary motor. Refer to Figure 118.

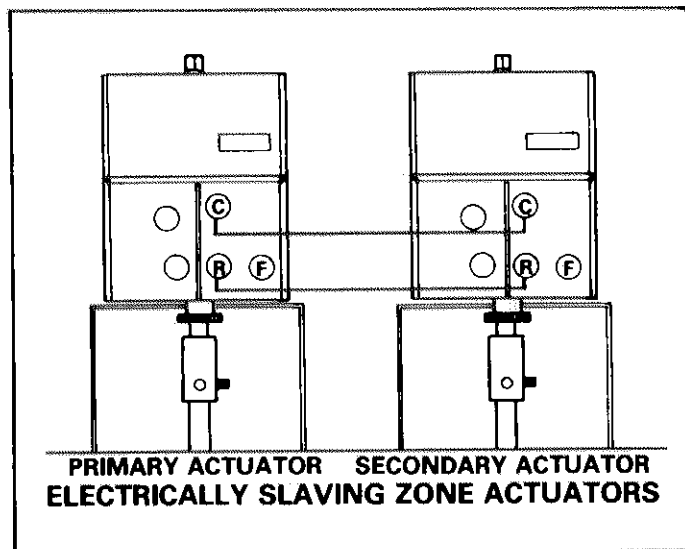

FIGURE 118

D - Performance Check

The following test requires a Load Simulator and DC voltmeter to check operation of each zone actuator.

- 1 - Connect Load Simulator to zone actuator as follows:
 - a - Turn off power to unit.
 - b - Set Load Simulator by aligning thumbwheel mark with null indicator. See Figure 119.
 - c - Remove wire from terminals C and R. DO NOT SHORT WIRE.
 - d - Connect Load Simulator and DC voltmeter leads as shown in Figure 119.

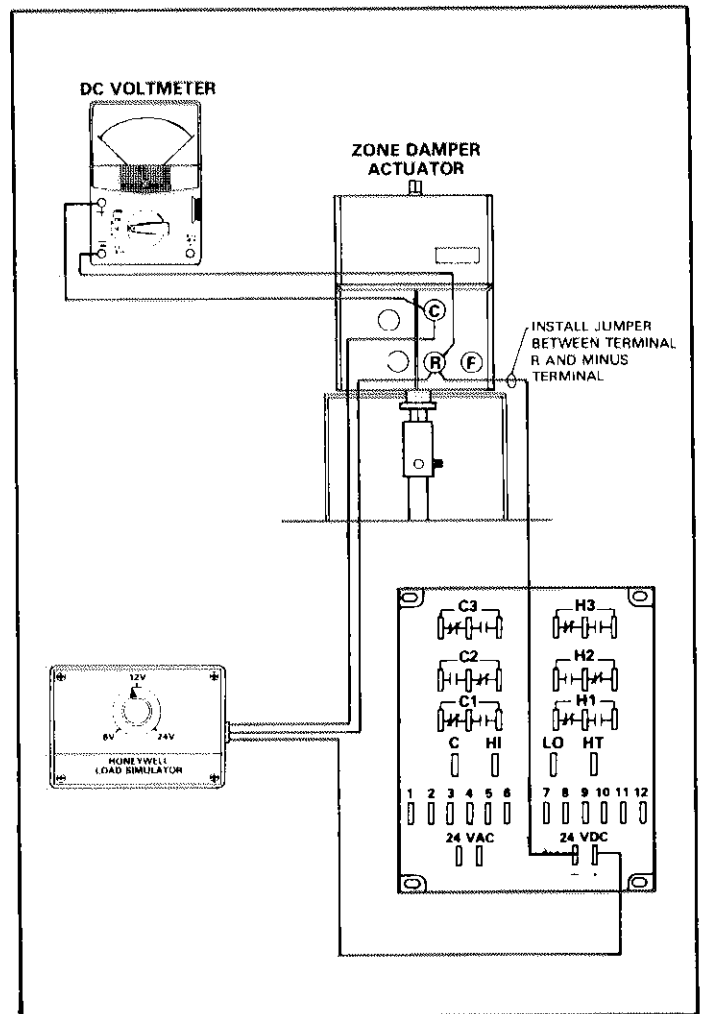

FIGURE 119

- 2 - Turn on power to unit.
- 3 - Allow a short warm-up period before proceeding with test. Full extension time of shaft normally takes 2 minutes after warm-up.
- 4 - Slowly rotate Load Simulator while observing DC voltmeter. Actuators will respond to command signal variations as described in basic function chart. Damper shaft is retracted at 10 volts and extended at 14 volts.

NOTE - Most portable voltmeters are accurate to +1 volt. Any variation in starting points should be consistent on voltmeter.

- 5 - Refer to "Electronic Circuit Troubleshooting" section on page 39 if the zone actuator does not respond correctly.
- 6 - Remove Load Simulator and DC voltmeter and reconnect leads to terminals at zone actuator.

III - MINIMUM CONSTANT AIR FLOW ADJUSTMENT (RVZ1 ONLY)

The RVZ1 is factory assembled so the zone head dampers remain closed with no demand from the room sensor. The zone damper can be field adjusted to allow a desired amount of constant air flow to individual zones.

The relative angular position between the hot and cold deck damper blades is adjustable from 0° (no air) to 90° (100% air). Each blade can be set at a maximum 45° from closed position, thus making a 90° total angle between blades. Table 19 lists the percentage of air available per dimensional opening of blade. Both the hot and cold deck blades must be set for the same opening to provide the desired percentage of minimum air.

The damper actuator travels 160° with an 80° swing either side of mid-position. Mid-position reflects a 12 VDC command signal which

ZONE CONTROL

TABLE 19

| Blade Angle 0° | Percent of Total Air By-passed with each blade Set at $\angle\theta$ or Dim. "A" | RVZ1-185/275/300/360 | | | | RVZ1-415/600 | | | |
|-------------------|----------------------------------------------------------------------------------|----------------------|------|---------|------|--------------|------|---------|------|
| | | 11 Zone | | 15 Zone | | 11 Zone | | 17 Zone | |
| | | in. | mm | in. | mm | in. | mm | in. | mm |
| 5 | 15% | 1/4 | 6.4 | 3/16 | 4.8 | 5/16 | 7.9 | 3/16 | 4.8 |
| 10 | 30% | 9/16 | 14.3 | 3/8 | 9.5 | 9/16 | 14.3 | 3/8 | 9.5 |
| 15 | 45% | 13/16 | 20.6 | 1/2 | 12.7 | 7/8 | 22.2 | 9/16 | 14.3 |
| 20 | 60% | 1-1/16 | 27.0 | 3/4 | 19.0 | 1-1/8 | 28.6 | 3/4 | 19.0 |
| 25 | 75% | 1-5/16 | 33.3 | 15/16 | 23.8 | 1-3/8 | 34.9 | 7/8 | 22.2 |
| 30 | 90% | 1-1/2 | 38.1 | 1-1/8 | 28.6 | 1-5/8 | 41.3 | 1-1/16 | 27.0 |
| 35 | 100% | 1-3/4 | 44.5 | 1-1/4 | 31.8 | 1-7/8 | 47.6 | 1-3/16 | 30.2 |
| 40 | 100% | 2 | 50.8 | 1-3/8 | 34.9 | 2-1/8 | 53.9 | 1-3/8 | 34.9 |
| 45 | 100% | 2-1/4 | 57.2 | 1-1/2 | 38.1 | 2-3/8 | 60.3 | 1-1/2 | 38.1 |

signifies a balance point at the particular zone. The total travel of the damper blade consists of the minimum air setting plus 80°. For example if the hot deck damper is set at 45° minimum air, the blade will travel 115° from closed position on a heating demand.

NOTE - Due to the air flow properties of single blade dampers, a 70° angle between blades is as efficient as a 90° angle and permits full continuous air.

Refer to the following procedure to adjust for minimum air.

- 1 - Attach load simulator to actuator as instructed in "D-Performance Check". Set simulator at 12 VDC so the actuator is approximately in mid position. Both hot and cold deck damper blades will be in the closed position.
- 2 - Remove cover from damper actuator. The wiper blade of actuator should be in the position shown in Figure 120. If the wiper blade is not centered, turn simulator until it is.

NOTE - The crankarm must be parallel to the wiper blade. If the crankarm is not parallel, loosen coupling at actuator and reposition linkage so that it is. See Figure 120.

- 3 - Loosen 2 set screws holding hot deck damper magnet arm to shaft. Refer to Figure 121. See Table 19 for percentage of air versus dimensional opening of blade. Turn magnet arm and blade clockwise until desired opening is obtained and then tighten set screws.
- 4 - Loosen 2 set screws holding cold deck damper magnet arm to shaft. Turn magnet arm and blade counterclockwise until the opening matches the hot deck blade. See Figure 121. Tighten set screws.
- 5 - Remove Load Simulator and DC voltmeter and reconnect leads to terminals at zone actuator.

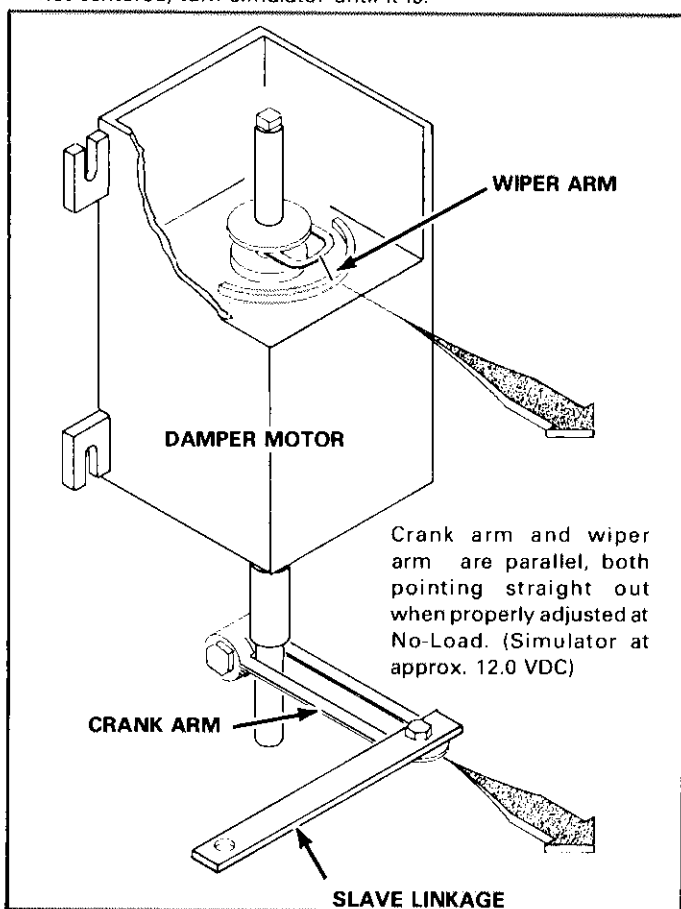

FIGURE 120

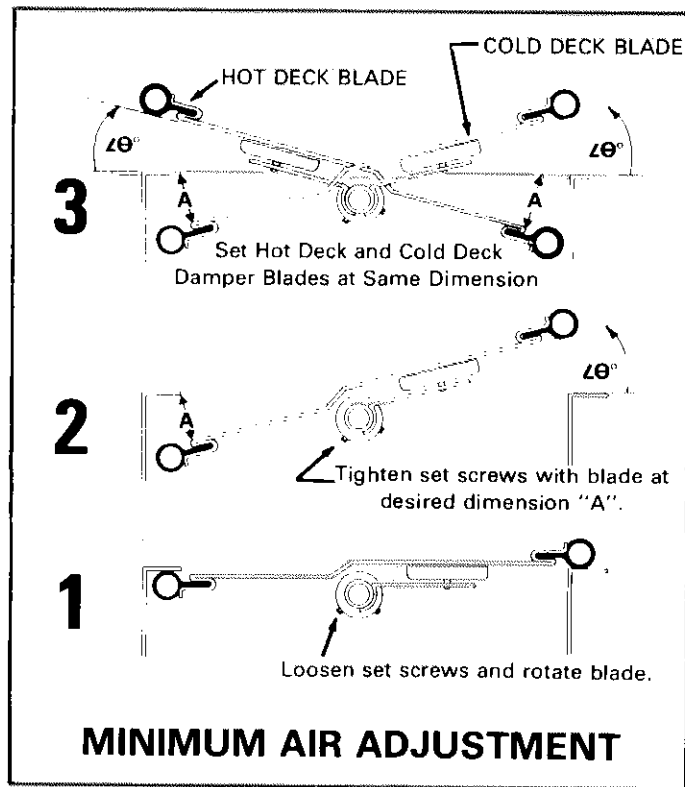

FIGURE 121

IV - PROBLEM ZONES

If a problem zone transmits a constant heating or cooling demand, remove that particular zone lead from A9 load analyzer module, until the problem is corrected.

FILTERS

Three types of filters are available; polyurethane, bag type filters and automatic roll filters.

I - POLYURETHANE FILTERS

- 1 - Remove access panel from the damper/filter cabinet to expose banks of filters. Grasp the bracket on chain at bottom of each bank. Simply pull chain and bring out filters. Refer to Figure 122.
- 2 - To clean the filter, vacuum or wash with mild soap and water. For increased efficiency, coat the filter with water soluble oil, No. P-8-5069, available from your Lennox dealer.

CAUTION - Some detergents have an adverse effect on the filter media, causing it to lose its flexibility or become soft. It is recommended that dish washing liquid be used. When cleaning the filter do not leave it soaking in cleaner; leave filter in cleaner only as long as it takes to clean it. Do not use any enzyme detergents or pre-soakers. After filter is clean, rinse it thoroughly before replacing in unit.

- 3 - Replace filters in unit noting arrangement and air flow direction. Refer to Figure 123(185, 275, 300, 360) or Figure 124(415, 600). Slide filters in on track, pulling chain and bracket in place.

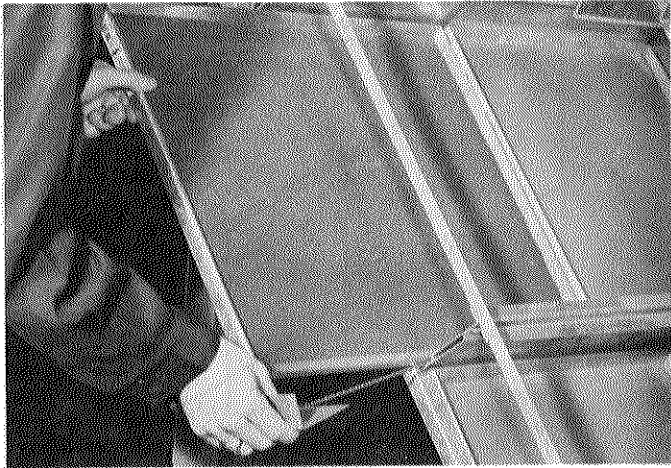

FIGURE 122

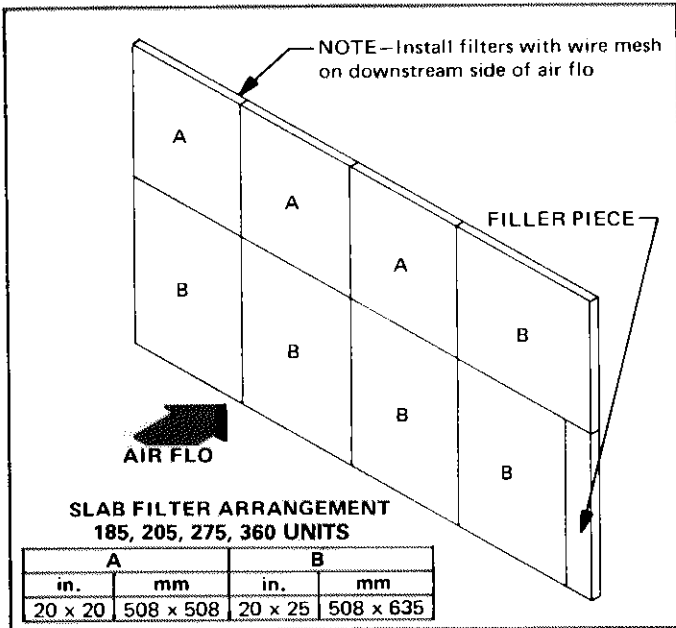

FIGURE 123

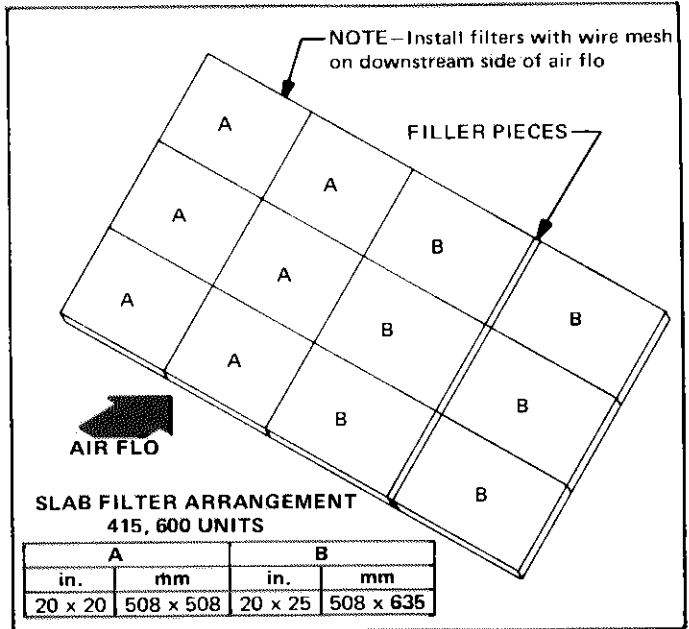

FIGURE 124

II - BAG ASSEMBLY FILTERS

- 1 - High efficiency bag assembly filters (non-cleanable) and polyurethane pre-filters (cleanable) are used.

IMPORTANT - The pre-filters must be cleaned regularly to extend the life of the bag filters. Be sure to reinstall pre-filter seal strips after each cleaning. Use the same procedure as for "I - Polyurethane Filters". Refer to pre-filter arrangement, Figure 125 (185, 205, 275, 300, 360) or Figure 126 (415, 600).

- 2 - To change bag assembly filters, pull old filters from unit as shown in Figure 127. Remove wire support rack from filter frame and reinstall on replacement filters:

- a - Thread rear connecting wire out of loops at the top rear of bag assemblies.

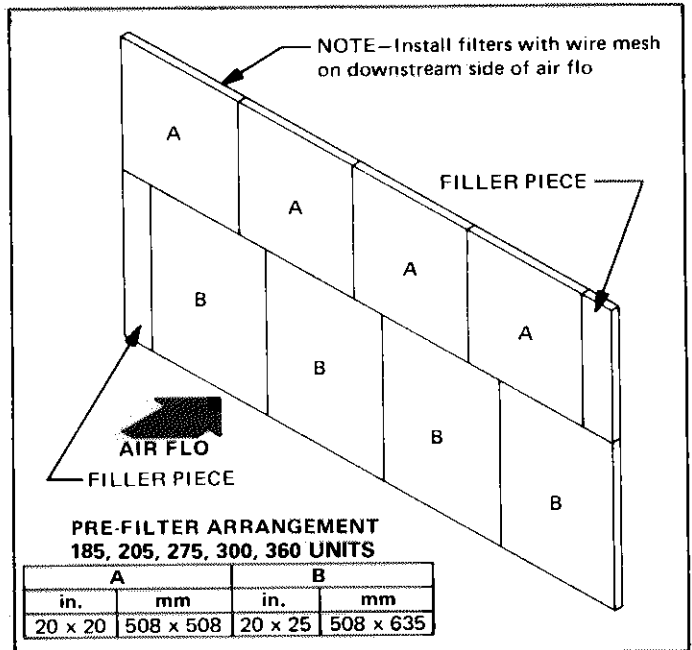

FIGURE 125

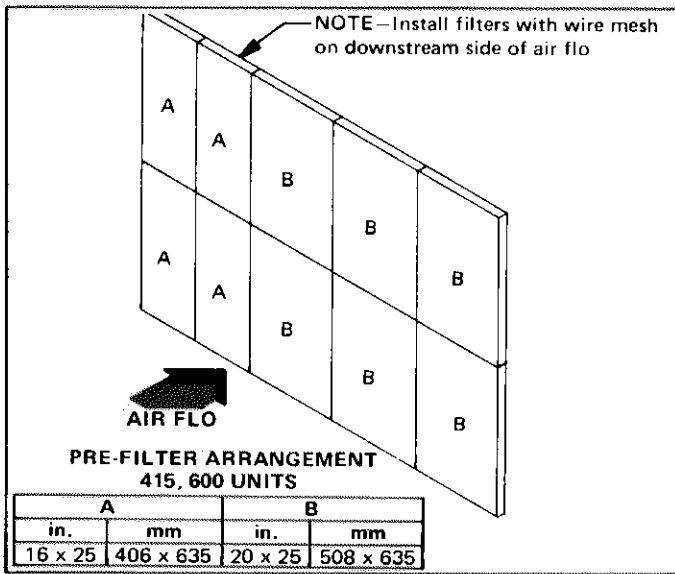

FIGURE 126

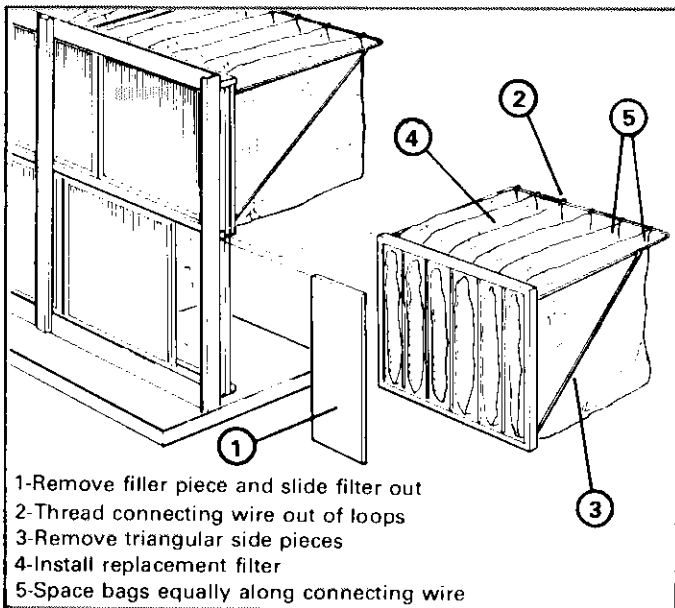

FIGURE 127

- b - Remove triangular side pieces by bowing out vertical wire until free of frame.
- c - Reverse procedures (a) and (b) to install on replacement filter frames.
- d - Slide the bags along the rear connecting wire until there is an equal amount of space between each bag assembly.
- e - Replace filter bag assemblies in unit. See Figure 128 (185, 275, 300, 360) or Figure 129 (415, 600) for arrangement.

III - AUTOMATIC ROLL FILTERS

Roll filters have a timer control with a pressure back-up control for advancement of filters. Two inch thick glass media is standard with 1/2" (13mm) synthetic media as optional.

A - Timer Control Adjustment

The adjustable timer control system assures that a fixed amount of media per 24 hours of unit operation will be introduced into air stream. (De-energized during nite-setback).

- 1 - The timer dial is calibrated in inches of media introduced in any 24 hour period of unit operation. Each timer is pre-set at the factory for "Normal" dust load operation.
- 2 - Pressure drop across the filter curtain, which may be determined

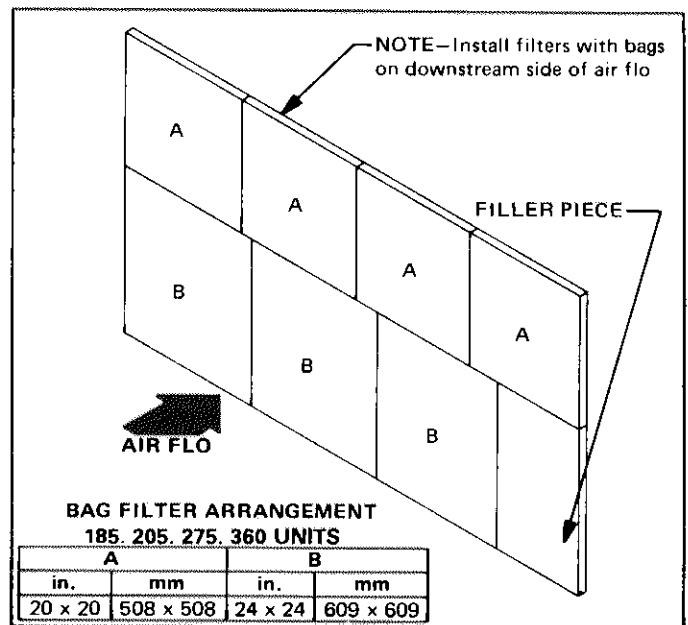

FIGURE 128

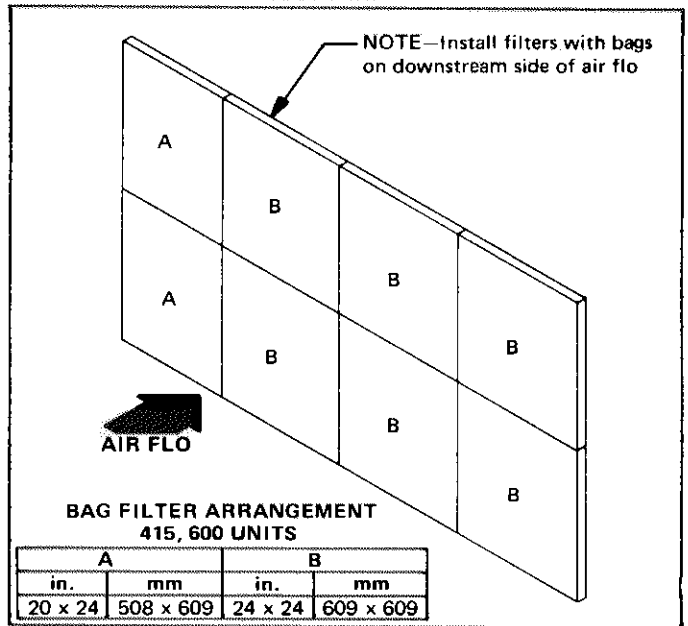

FIGURE 129

by use of a draft gauge, should be 0.45" - 0.5" w.c. (11,4 mm - 12,7 mm w.c.).

- 3 - Should dust load to which filters are actually subjected be more or less than "normal," simply reset timer to desired amount of media to be introduced per 24 hours of operation to keep pressure drop across filter curtain between 0.45" - 0.5" w.c. (11,4 mm - 12,7 mm w.c.).

| AIR FILTER TIME FACTORY SETTING | | | | | | |
|---------------------------------|---------------|------|---------------------------------------------|------|----------------------------------------|---------------------------------------------------------------|
| Unit | Filter Length | | Media indexed per 24 hrs. of unit operation | | Timer cycle interval (hours - minutes) | Approximate media "life" at recommended timer setting (hours) |
| | in. | mm | in. | mm | | |
| 185,275 | 72 | 1828 | 2-1/2 | 63,5 | 9 - 36 | 6816 |
| 300,360 | | | | | | |
| 415,600 | 90 | 2286 | 3-1/4 | 82,5 | | |

- 4 - Metering cam assures that 1" (25,4 mm) of clean media is introduced. Timer resets and starts on a new cycle.
- 5 - Timer motor operates until timer interval is completed, at which time 1" (25,4 mm) of clean media is introduced. Timer resets and starts on a new cycle.
- 6 - Media movement rotates splined roller on which metering cam is mounted. Cam follower of media metering switch is actuated by rotation of cam which stops drive motor until another time interval has elapsed.

B - Pressure Back-up Control Operation and Adjustment

The back-up pressure control introduces media into airstream whenever selected pressure differential across filter curtain is reached.

- 1 - Pressure differential is determined by air velocity through media and filter loading.
- 2 - Each pressure differential switch is preset at factory to operate at a system velocity of 500 fpm (2,54 m/s).
- 3 - To change velocity setting:
 - a - Select proper control scale from the chart.

| PRESSURE CONTROL ADJUSTMENT | | | |
|-----------------------------|------|----------|---------|
| fpm | m/s | in. w.c. | mm w.c. |
| 600 | 3,04 | 0.68 | 17.2 |
| 550 | 2,79 | 0.59 | 14.9 |
| 500 | 2,54 | 0.50 | 12.7 |
| 450 | 2,28 | 0.41 | 10.4 |
| 400 | 2,03 | 0,34 | 8.6 |
| 350 | 1,77 | 0.27 | 6.8 |
| 300 | 1,52 | 0.21 | 5.3 |

- b - Calibration or actuation point of pressure switch is indicated by scale affixed to transparent range spring enclosed. Recalibration to another setting within range of control is accomplished by turning center adjusting screw. Refer to Figure 130.

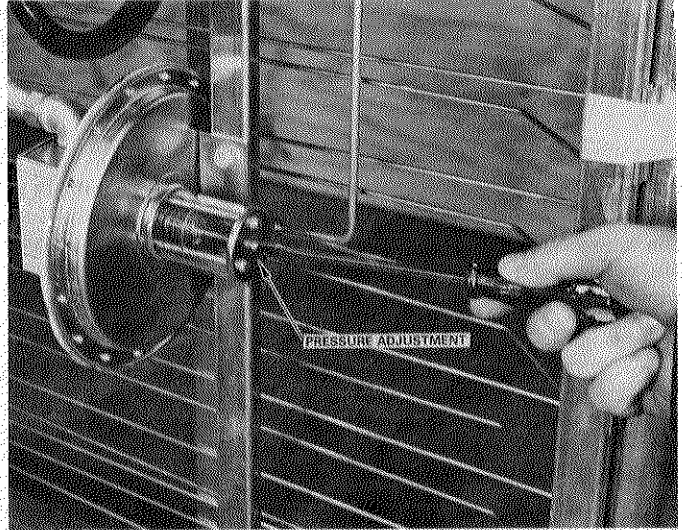
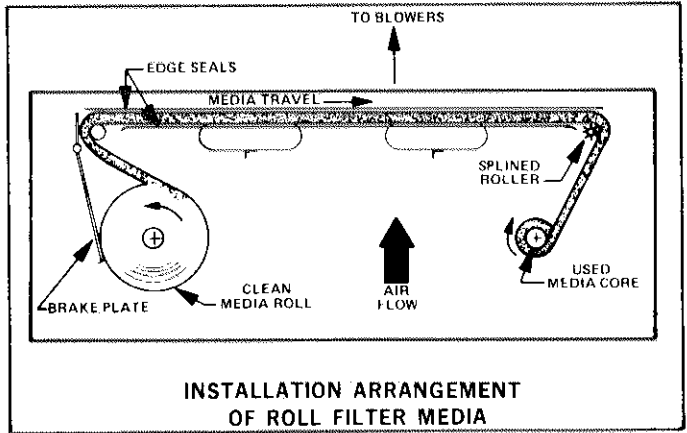

FIGURE 130



INSTALLATION ARRANGEMENT OF ROLL FILTER MEDIA

FIGURE 131

C - Changing Roll Filters

Refer to Figure 131 for installation arrangement.

1. Open doors on both ends of filter.
- 2 - Install small trunnion (from top of empty core) on top of core in clean media roll and large trunnion (from bottom of empty core) into bottom of core in media roll.
- 3 - Insert fresh media roll (with trunnions in place) into filter opposite the drive end of filter. Large trunnions must be on bottom and MEDIA MUST FEED FROM CLEAN ROLL SO THAT EXTERIOR OF CLEAN ROLL BECOMES AIR ENTERING SIDE OF FILTER WHEN MEDIA IS UNROLLED.
- 4 - Rotate latch handle to closed position to lock roll in place.
- 5 - At used media end of filter inset large lower trunnion (from used media core) into bottom end of empty media core.
- 6 - Insert empty core and trunnions into trunnion supports in drive end of filter with gear trunnion engaging the pinion gear.

- 7 - Mesh gear trunnion and drive pinion, and rotate latch handle to closed position.
- 8 - Feed lead end of media roll between idler roller and filter housing.
- 9 - Pull media through filter between front and rear grids and between edge seals being careful that media enters both edge seals evenly.
- 10 - Feed end of media around splined roller and empty core.
- 11 - Metal core is provided with teeth to engage media. Make one full wrap on core to insure proper engagement.
- 12 - Recheck above steps to be sure all steps have been followed correctly. Filter is now ready to operate. Figure 131 illustrates roll filter operation.

SERVICE FLOW CHARTS

With equipment as sophisticated as this, it can often be difficult to locate the source of trouble from a given set of conditions.

The following service flow charts are designed to direct you to the likely source of trouble from certain observed or readily determined conditions.

When going through the following service flow charts, always start with "Supply And Return Air Blower Operation." Once the indoor and return air blowers are running, go to the flow charts for "Hot Deck" or "Cold Deck." The schematic wiring diagrams provided on the unit are to assist you in understanding the various circuits.

SERVICE FLOW CHART FOR INDOOR AND RETURN AIR BLOWERS

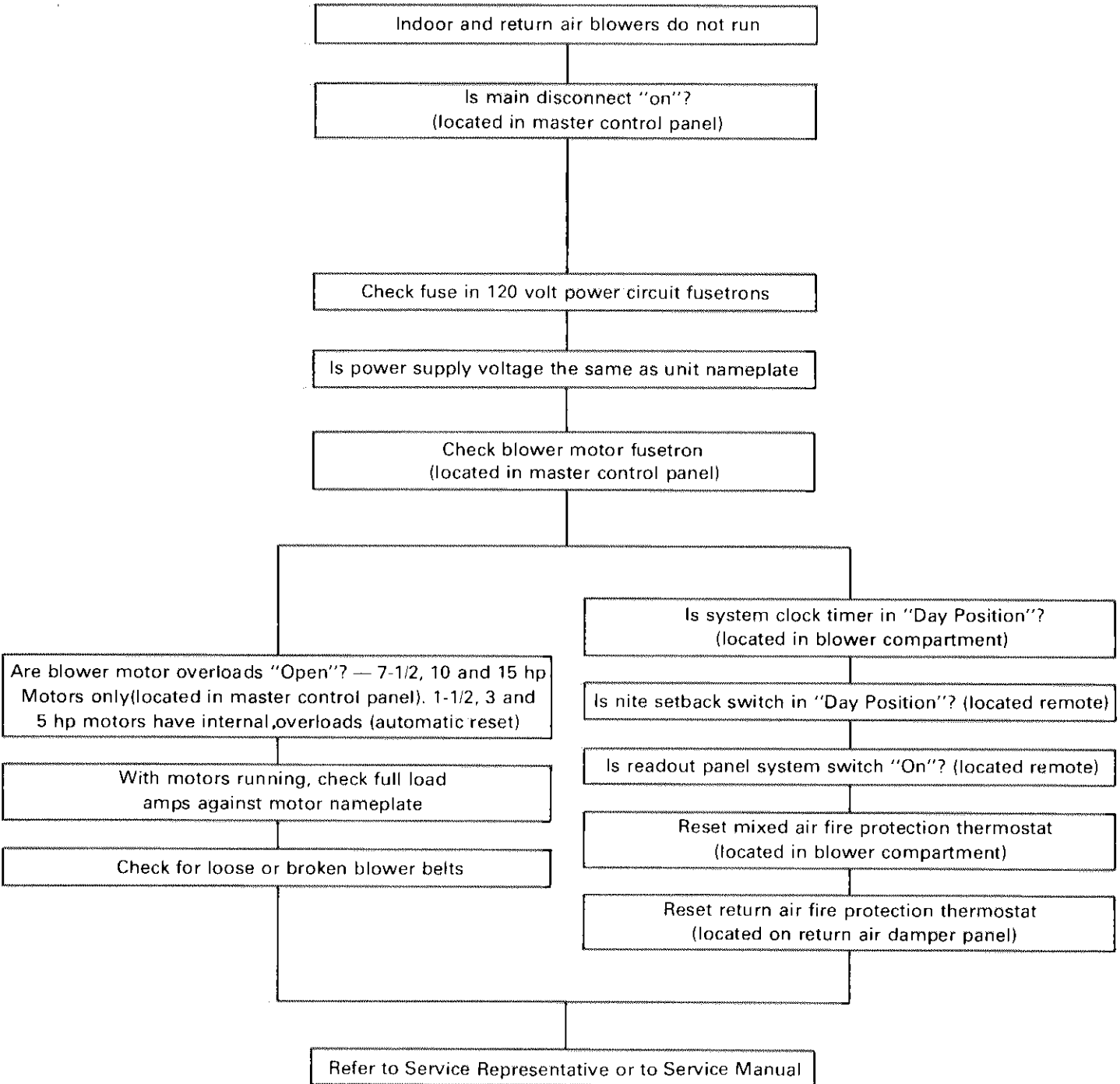

SERVICE FLOW CHART FOR HOT DECK OR HEATING SECTIONS

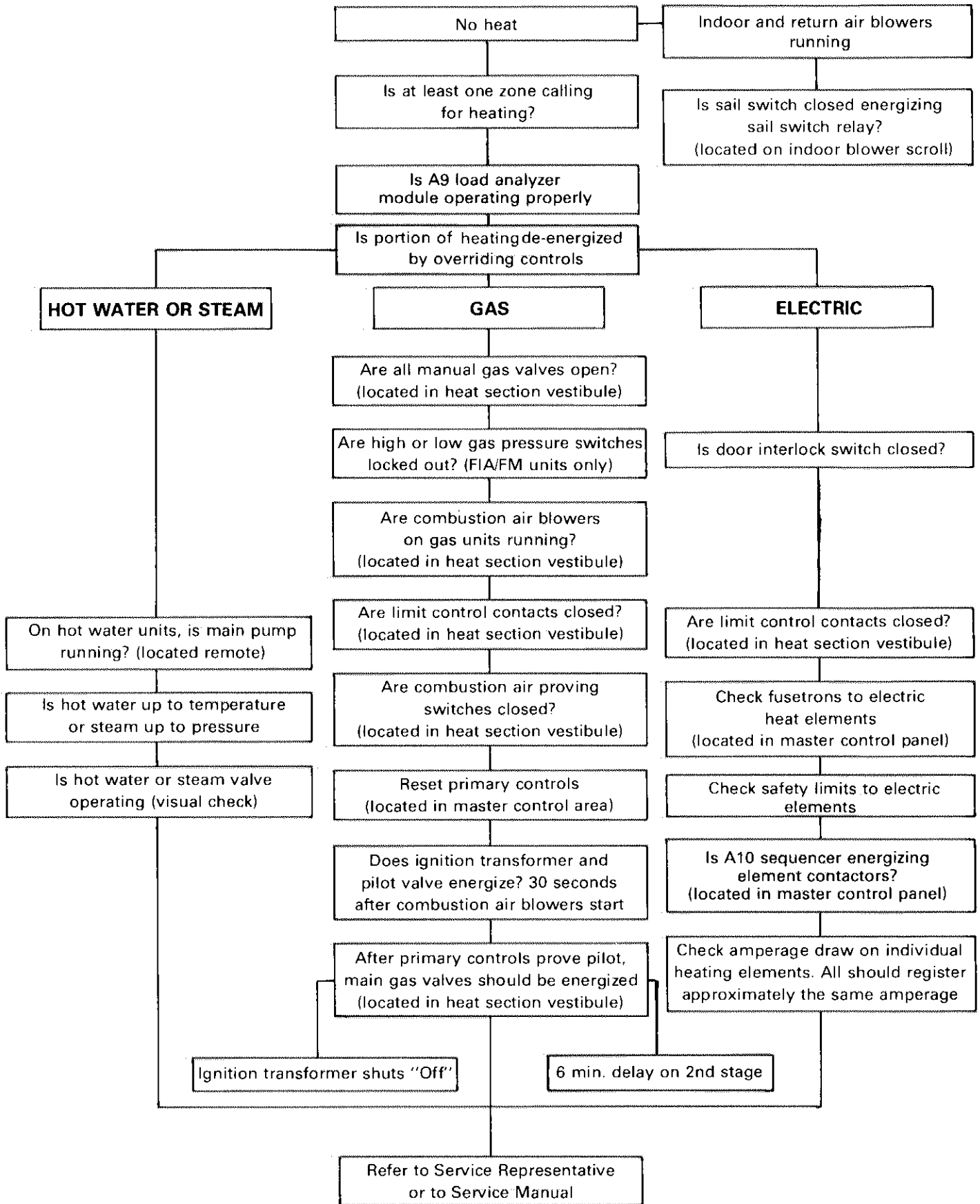

SERVICE FLOW CHART FOR COLD DECK OR COOLING SECTIONS

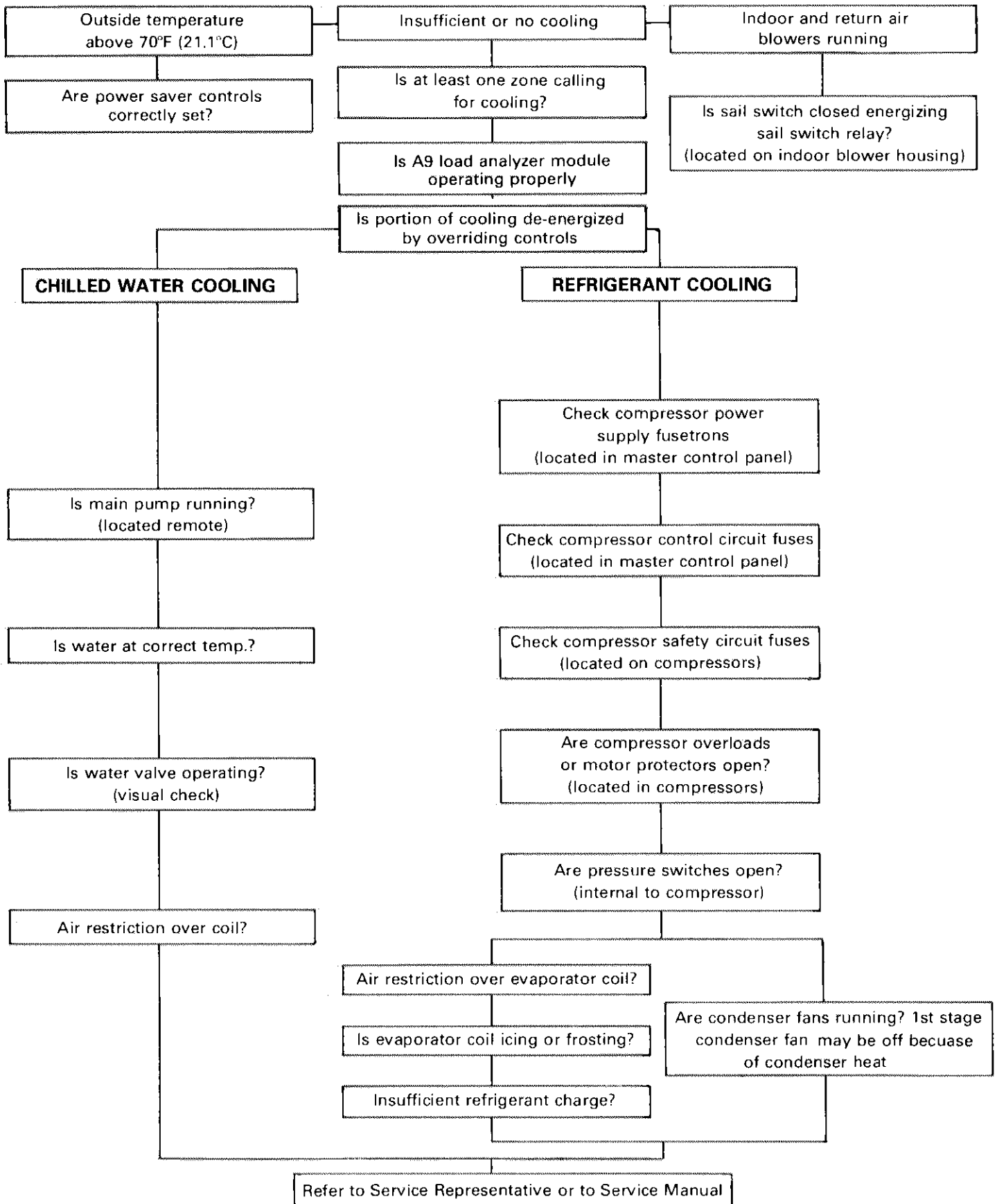

SERVICE FLOW CHARTS