



Installation, operating and maintenance **ECOLEAN - EAC/EAR**



- Providing indoor climate comfort



Revision 2

TABLE OF CONTENTS

PREFACE	PAGE 2
DATA PAGE FOR UNIT COMMISSIONING	PAGE 3
1.- GENERAL CHARACTERISTICS	PAGE
1.1.- TECHNICAL DATA	4-5
1.2.- ELECTRICAL DATA	6
1.3.- COMPONENT	7
1.4.- OPERATION LIMITS	8-9
1.5.- PRESSURE DROP IN THE WATER SYSTEM	10-11
1.6.- HYDRAULIC SYSTEM DATA	12
1.7.- SAFETY DEVICES	13-15
1.8.- PIPING DRAWINGS	16-19
1.9.- DIMENSIONS	20-22
1.10.- OPTIONS	23-25
2.- INSTALLATION	PAGE
2.1.- SITE AND SHIPPING GUIDANCE	26
2.2.- UNIT LIFTING	26
2.3.- ANTIVIBRATION MOUNTING	27
2.4.- INSTALLATION CLEARANCES	28
2.5.- DETAILING SPRING ANTI-VIBRATION POSITION	29
2.6.- WEIGHT APPROXIMATE DISTRIBUTION. (EAC/R 1003-1804 SM)	29
2.7.- UNIT INSTALLATION	30-31
2.8.- ELECTRICAL CONNECTIONS	32
3.- COMMISSIONING AND OPERATION	PAGE
3.1.- STEPS TO FOLLOW FOR COMMISSIONING THE UNITS	33
3.2.- CHECKING THE WATER FLOW RATE	34
3.3.- CORROSION RESISTANCE OF COPPER AND STAINLESS STEEL OF PLATES EXCHANGER	35
4.- MAINTENANCE	PAGE
4.1.- PREVENTIVE MAINTENANCE	36
4.2.- CORRECTIVE MAINTENANCE	37
4.3.- FAILURE DIAGNOSIS	37

Our company's products comply with European standards.



The manufacturing of EcoLean™ answers to ISO9001 control quality system.



Lennox have been providing environmental solutions since 1895, our range of EcoLean™ reversible chillers continues to meet the standards that have made LENNOX a household name. Flexible design solutions to meet YOUR needs and uncompromising attention to detail. Engineered to last, simple to maintain and Quality that comes as standard. Information on local contacts at www.lennox europe.com.

All the technical and technological information contained in this manual, including any drawing and technical descriptions provided by us, remain the property of Lennox and must not be utilised (except in the operation of this product), reproduced, issued to or made available to third parties without the prior written agreement of Lennox.

The specifications and technical characteristics in this booklet are given for information purposes. The manufacturer reserves the right to modify them without prior notice or obligation to modify in a similar manner, the equipments previously supplied.

PREFACE

Please read this operating manual prior to commissioning the EcoLean™ chiller. Familiarize yourself with the operation and control of the EcoLean™ chiller and closely follow the instructions.

We would like to stress the importance of training with respect to the correct handling of the chiller. Please consult Lennox on the options available in this field.

It is important that this manual be stored in a permanent location in the vicinity of the EcoLean™ chiller.

For the sake of clarity, important items in this manual are shown as follows:

Text	Important general instructions
	Danger of damage to the chiller

This manual contains important instructions regarding the commissioning of the EcoLean™ chiller. It also includes important instructions to prevent personal injury and damage to the machine during operation. Furthermore, in order to promote fault-free operation of the chiller, maintenance information has been included.

Please do not hesitate to contact one of our employees should you require further information on specific chiller subjects.

Order related documentation will be forwarded under separate cover. This documentation consists of:

- CE declaration
- Operating manual for control system
- Installation Operating manual
- Wiring diagram
- Unit detail are given on unit nameplate

FOR NETHERLAND: the STEK logbook, including the required certificates will be handed over by the installation technician or left with the machine following commissioning by Lennox. The data published in this manual is based on the most recent information available. It is supplied conditional to later modifications. We reserve the right to modify the construction and/or design of our EcoLean™ chillers, at any time, without prior notification or obligation to adapt previous supplies accordingly.

Any work on the Chiller should be carried out by trained and licensed competent technician.

The following risks are present on the unit:

- risk of electrical shock.
- risk of injury from rotating parts.
- risk of injury from sharp edges and heavy weight.
- risk of injury from high pressure gas.
- risk of injury from high and low temperatures components.

DATA PAGE FOR UNIT COMMISSIONING

UNIT: _____ SERIAL No.: _____

CONTROL PANEL IDENTIFICATION CODE _____

INSTALLATION ADDRESS: _____

INSTALLER: _____ INSTALLER TEL.: _____

INSTALLER ADDRESS: _____

DATE OF COMMISSIONING: _____

CHECKS:

SUPPLY VOLTAGE: _____ RATED VOLTAGE OF THE UNIT: _____

SI NO

- UNIT ON RUBBER ANTIVIBRATION MOUNTS
- GENERAL POWER SUPPLY CONNECTION
- CONTROL PANEL CONNECTION (OPTION)
- COMPRESSOR OIL LEVEL INDICATOR
- HYDRAULIC CONNECTION
- PURGED OF THE INSTALLATION

DATA INPUT:

COOLING CYCLE

Air Input Temperature, Coil: _____ °C

Water Output Temperature: _____ °C

Water Input Temperature: _____ °C

High Pressure: _____

Low Pressure: _____

HEATING CYCLE

Air Input Temperature, Coil: _____ °C

Water Output Temperature: _____ °C

Water Input Temperature: _____ °C

High Pressure: _____

Low Pressure: _____

ELECTRIC POWER CONSUMPTION (Amp.)

Compressor 1 _____/_____/_____

Fan 1 _____/_____/_____

Compressor 2 _____/_____/_____

Fan 2 _____/_____/_____

Compressor 3 _____/_____/_____

Fan 3 _____/_____/_____

Compressor 4 _____/_____/_____

Fan 4 _____/_____/_____

Compressor 1 _____/_____/_____

Fan 1 _____/_____/_____

Compressor 2 _____/_____/_____

Fan 2 _____/_____/_____

Compressor 3 _____/_____/_____

Fan 3 _____/_____/_____

Compressor 4 _____/_____/_____

Fan 4 _____/_____/_____

Options Installed: _____

Comments: _____

1.- GENERAL CHARACTERISTICS

1.1.- TECHNICAL DATA

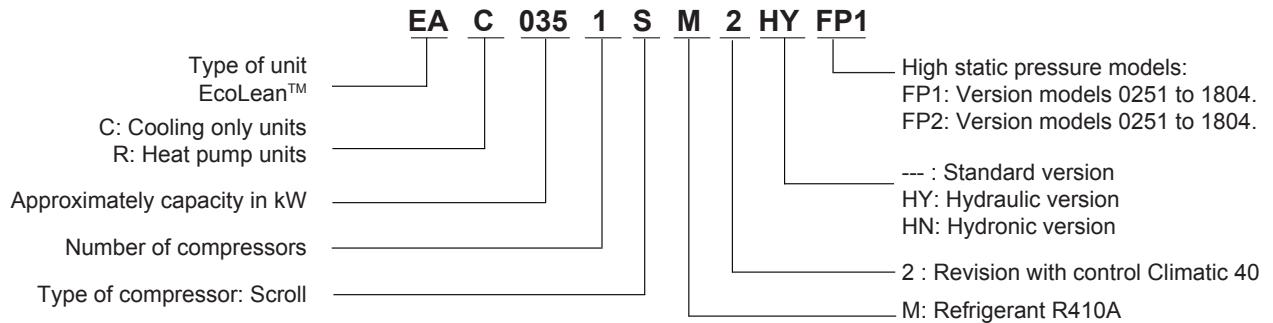

COOLING ONLY

EAC MODELS		0251SM	0291SM	0351SM	0431SM	0472SM	0552SM	0672SM	0812SM	1003SM	1103SM	1203SM	1303SM	1403SM	1604SM	1804SM	
Cooling capacity (*)	kW	22,1	25,9	32,0	37,6	44,1	50,7	63,4	75,4	88,2	102	112	126	139	149	174	
Compressor	Nr/type	1 / scroll				2 / scroll				3 / scroll				4 / scroll			
Hydraulic connections		1 1/2"G				2"G				2 1/2"G				DN80			
Min. water rate	m³/h	3,16	3,72	4,4	5,3	6,05	7,07	8,6	10,39	12,38	13,9	15,76	17,48	18,86	21,06	24,77	
Net weight	Standard	kg	237,5	245,8	262,7	292	469,6	481,9	518,4	561,9	640	809	938	990	1019	1328	1683
	FP1	kg	252,5	260,8	277,7	297,4	499,6	511,9	548,4	591,9	680	849	978	1030	1059	1368	1763
	FP2	kg	272,5	280,8	297,7	317,4	539,6	551,9	588,4	631,9	680	849	978	1030	1059	1368	1763
Refrigerant	kg	5,5	6,11	8	9	11	12,2	16,1	18,5	21,8	25,3	26,7	29,7	33,7	36,2	42,1	

HEAT PUMP

EAR MODELS		0251SM	0291SM	0351SM	0431SM	0472SM	0552SM	0672SM	0812SM	1003SM	1103SM	1203SM	1303SM	1403SM	1604SM	1804SM	
Cooling capacity (*)	kW	22,1	25,9	32,0	37,6	44,1	50,7	63,4	75,4	88,2	102	112	126	139	149	174	
Heating capacity (**)	Nr/type	23,6	27,6	33,6	37,8	47,8	54,7	68,0	75,7	95,0	108	118	130	143	159	180	
Compressor	Nr/type	1 / scroll				2 / scroll				3 / scroll				4 / scroll			
Hydraulic connections		1 1/2"G				2"G				2 1/2"G				DN80			
Min. water rate	m³/h	3,16	3,72	4,4	5,3	6,05	7,07	8,6	10,39	12,38	13,9	15,76	17,48	18,86	21,06	24,77	
Net weight	Standard	kg	243	251	271	300	480	492	534	578	663	831	964	1016	1045	1347	1703
	FP1	kg	257,5	265,8	285,7	305,4	509,6	521,9	564,4	607,9	703	871	1004	1056	1085	1387	1783
	FP2	kg	277,5	285,8	305,7	325,4	549,6	561,9	604,4	647,9	703	871	1004	1056	1085	1387	1783
Refrigerant	kg	5,8	6,5	8,7	10	11,4	12,7	16,8	19,3	22,7	26,3	27,9	31	35,1	37,7	43,9	

(*) Cooling capacity: Outside temperature: 35°C / Inlet/outlet water temperature: 12/7°C

(**) Heating capacity: Outside temperature: 7°C DB / 6°C WB / Inlet/water outlet temperature: 40/45°C

HYDRAULIC VERSION / HYDRONIC VERSION

MODELS	0251SM	0291SM	0351SM	0431SM	0472SM	0552SM	0672SM	0812SM	1003SM	1103SM	1203SM	1303SM	1403SM	1604SM	1804SM	
Pump type	Horizontal multistage centrifugal pump															
Expansion vessel Capacity (l)	12				18				35				50			
Set pressure Security valves (bar)	3															
Expansion vessel (bar)	4															
Buffer tank (***) Capacity (l)	75				100				240				350			

(***) Only in units with Hydronic module

1.- GENERAL CHARACTERISTICS

1.1.- TECHNICAL DATA

STANDARD FAN UNITS



MODELS		0251SM	0291SM	0351SM	0431SM	0472SM	0552SM	0672SM	0812SM	
Fan type		Axial - Direct coupling				900 rpm		1~230V		
Fan number		1				2				
Air flow rate		m³/h	9750	11500	11300	11000	9750+9750	11500+11500	11300+11300	11000+11000
Power input		kW	0,69	0,84	0,84	0,84	0,69+0,69	0,84+0,84	0,84+0,84	0,84+0,84

MODELS		1003SM	1103SM	1203SM	1303SM	1403SM	1604SM	1804SM		
Fan type		Axial - Direct coupling				3~400V				
Fan number		2						4		
Air flow rate		m³/h	High	18100+18100	22700+18100	22700+18100	22700+22700	22500+22700	23500+23500	28600+28600
			Low	15000+15000	18000+15000	18000+15000	18000+18000	17500+18000	18500+18500	22600+22600
Power input		kW	High	1,05+1,05	2+1,05	2+1,05	2+2	2+2	2+2	2,1+2,1
			Low	0,77+0,77	1,25+0,77	1,25+0,77	1,25+1,25	1,25+1,25	1,25+1,25	1,54+1,54
Fan speed		rpm	High	700+700	900+700	900+700	900+900	900+900	900+900	700+700+700+700
			Low	550+550	700+550	700+550	700+700	700+700	700+700	550+550+550+550

HIGH STATIC FAN PRESSURE UNITS

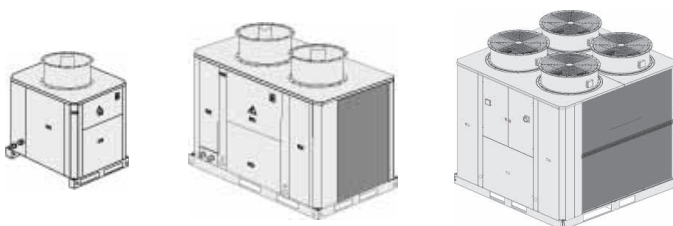

AIR AVAILABLE STATIC PRESSURE UP TO 125 Pa - FP1 VERSION

MODELS		0251SM	0291SM	0351SM	0431SM	0472SM	0552SM	0672SM	0812SM	1003SM to 1403SM	1604SM	1804SM		
Fan type		Axial - Direct coupling 1450 rpm 1~230V							Axial - Direct coupling 900 rpm (Low speed) 3~400V					
Fan number		1				2				4				
Available static pressure Pa	50	Air flow rate	m³/h	11500	11500	11000	10500	2300	23000	22000	21000	19000+19000	21000+21000	28000+28000
		Power input	kW	1,7	1,7	1,65	1,65	3,4	3,4	3,3	3,3	5	5	10
	75	Air flow rate	m³/h	9600	9600	9200	8800	19200	19200	18400	17600	18000+18000	19000+19000	24000+24000
		Power input	kW	1,65	1,65	1,6	1,6	3,3	3,3	3,2	3,2	5,1	5,1	10,2
	100	Air flow rate	m³/h	8500	8500	8100	7700	17000	17000	16200	15400	17000+17000	17000+17000	22000+22000
		Power input	kW	1,6	1,6	1,55	1,55	3,2	3,2	3,1	3,1	5,2	5,2	10,4
	125	Air flow rate	m³/h	7200	7200	6900	6600	14400	14400	13800	13200	15000+15000	16000+16000	20000+20000
		Power input	kW	1,55	1,55	1,5	1,5	3,1	3,1	3	3	5,3	5,3	10,6

AIR AVAILABLE STATIC PRESSURE UP TO 250 OR 350 Pa - FP2 VERSION

MODELS		0251SM	0291SM	0351SM	0431SM	0472SM	0552SM	0672SM	0812SM	1003SM to 1403SM	1604SM	1804SM		
Fan type		Axial "short case" - Direct coupling 1450 rpm 3~400V							Axial "short case" - Direct coupling 1450 rpm (High speed) 3~400V					
Fan number		1				2				2		4		
Available static pressure Pa	150	Air flow rate	m³/h	12400	12400	11900	11500	24800	24800	23800	23000	22000+22000	24000+24000	34000+34000
		Power input	kW	2,45	2,45	2,4	2,35	4,9	4,9	4,8	4,7	9,2	9,2	18,4
	200	Air flow rate	m³/h	10800	10800	10400	10000	21600	21600	20800	20000	20000+20000	22000+22000	28000+28000
		Power input	kW	2,3	2,3	2,3	2,25	4,6	4,6	4,6	4,5	9,3	9,3	18,6
	250	Air flow rate	m³/h	9200	9200	8800	8500	18400	18400	17600	17000	18000+18000	19000+19000	24000+24000
		Power input	kW	2,3	2,3	2,3	2,3	4,6	4,6	4,6	4,6	9,4	9,4	18,8
	300	Air flow rate	m³/h	7800	7800	7500	7250	15600	15600	15000	14500	N/A		
		Power input	kW	2,4	2,4	2,4	2,45	4,8	4,8	4,8	4,9			
	350	Air flow rate	m³/h	6800	6800	6500	6250	13600	13600	13000	12500	N/A		
		Power input	kW	2,45	2,45	2,45	2,5	4,9	4,9	4,9	5			

N/A: Not available

1.- GENERAL CHARACTERISTICS

1.2.- ELECTRICAL DATA

STANDARD FAN UNITS



MODELS		0251SM	0291SM	0351SM	0431SM	0472SM	0552SzM	0672SM	0812SM
Maximum power (kW)		10,79	12,64	16,39	17,74	21,58	25,28	32,78	35,48
Maximum Current (A)	3N~400V	24,00	25,40	29,00	34,40	48,00	50,80	58,00	68,80
LRC (A)	3N~400V	114	121,4	161,4	201,4	138	146,8	190,4	235,8
Starting current (A) (*)	3N~400V	97,4	103,7	137,7	171,7	121,4	129,1	166,7	206,1

MODELS		1003SM	1103SM	1203SM	1303SM	1403SM	1604SM	1804SM
Maximum power (kW)	High	42,6	51,1	56,7	62,3	54,8	71,6	83,0
	Low	42,0	50,0	55,6	60,8	53,3	70,1	81,9
Maximum Current (A)	3N~400V High	79,8	88,6	97,6	107,7	118,5	132,0	151,6
	Low	78,0	86,0	95,0	104,3	115,1	128,6	148,0
LRC (A)	3N~400V High	246,8	255,6	282,6	331,2	342,0	299,0	336,6
	Low	245,0	253,0	280,0	327,8	338,6	295,6	333,0
Starting current (A) (*)	3N~400V High	217,1	225,9	248,8	290,4	301,2	269,3	302,9
	Low	215,3	223,3	246,3	287,0	297,8	265,9	299,3

Maximum power calculated for compressor operation at +12,5/65°C.

(*) Starting current 2 cycles later from compressor starts (4 mseg).

HIGH STATIC FAN PRESSURE UNITS

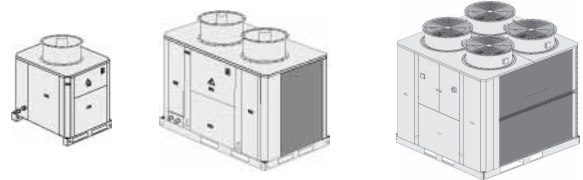

FP1 VERSIONS

MODELS		0251SM	0291SM	0351SM	0431SM	0472SM	0552SM	0672SM	0812SM
Maximum power (kW)	3N~400V	11,8	13,5	17,2	18,6	23,6	27,0	34,4	37,1
Maximum Current (A)	3N~400V	29,0	30,0	33,6	39,0	58,0	60,0	67,2	78,0
LRC (A)	3N~400V	119,0	126,0	166,0	206,0	148,0	156,0	199,6	245,0
Starting current (A) (*)	3N~400V	102,4	108,3	142,3	176,3	131,3	138,3	175,9	215,3

MODELS		1003SM	1103SM	1203SM	1303SM	1403SM	1604SM	1804SM
Maximum power (kW)	3N~400V	45,5	53,0	58,6	63,3	55,8	72,6	88,8
Maximum Current (A)	3N~400V	84,6	91,8	100,8	109,3	120,1	133,6	161,2
LRC (A)	3N~400V	251,6	258,8	285,8	332,8	343,6	300,6	346,2
Starting current (A) (*)	3N~400V	221,9	229,1	252,1	292,0	302,8	270,9	312,4

FP2 VERSIONS

MODELS		0251SM	0291SM	0351SM	0431SM	0472SM	0552SM	0672SM	0812SM
Maximum power (kW)	3N~400V	12,4	14,1	17,9	19,2	24,8	28,2	35,7	38,3
Maximum Current (A)	3N~400V	25,4	26,4	30,0	35,5	50,8	52,8	60,0	71,0
LRC (A)	3N~400V	115,4	122,4	162,4	202,5	140,8	148,8	192,4	238,0
Starting current (A) (*)	3N~400V	98,8	104,7	138,7	172,8	124,2	131,1	168,7	208,3

MODELS		1003SM	1103SM	1203SM	1303SM	1403SM	1604SM	1804SM
Maximum power (kW)	3N~400V	49,8	57,3	62,9	67,6	60,1	76,9	97,4
Maximum Current (A)	3N~400V	91,2	98,4	107,4	115,9	126,7	140,2	174,4
LRC (A)	3N~400V	258,2	265,4	292,4	339,4	350,2	307,2	359,4
Starting current (A) (*)	3N~400V	228,5	235,7	258,6	298,6	309,4	277,5	325,7

Maximum power calculated for compressor operation at +12,5/65°C.

(*) Starting current 2 cycles later from compressor starts (4 mseg).

HYDRAULIC / HYDRONIC VERSION (STANDAR / FP1 / FP2 UNITS)

MODELS EAC / EAR HY - HN		0251SM	0291SM	0351SM	0431SM	0472SM	0552 SM	0672SM	0812SM
Absorbed power (kW)		0,72	0,72	1,10	1,10	1,17	1,17	1,55	1,55
Maximum current (A)	3~400V	1,40	1,40	1,70	1,70	1,70	1,70	2,80	2,80

MODELS EAC / EAR HY - HN		1003SM	1103SM	1203SM	1303SM	1403SM	1604SM	1804SM
Absorbed power (kW)		2,45	2,45	2,45	2,45	2,93	2,93	3,70
Maximum current (A)	3~400V	4,95	4,95	4,95	4,95	4,8	4,80	6,80

1.- GENERAL CHARACTERISTICS

1.3.- COMPONENTS

The EcoLean™ system comprises a water cooler or air/water pump combined with a series of hydraulic accessories obtaining the Hydraulic or Hydronic version.

COMPONENTS:

HYDRONIC VERSION:

1,2,3,4,5,6,7,8,9,10,11.

HYDRAULIC VERSION:

1,4,5,6,7,8,9,10,11.

- 1.- Detachable water filter
- 2.- Water tank
- 3.- Water tank heater (in option)
- 4.- Safety valve
- 5.- Manometer
- 6.- Expansion vessel

- 7.- Water pump
- 8.- Air purge valve
- 9.- Plate exchanger
- 10.- Flow switch
- 11.- Drain valve
- 12.- Water isolation valves (in option)

HYDRONIC VERSION

Models 0251SM to 0812SM

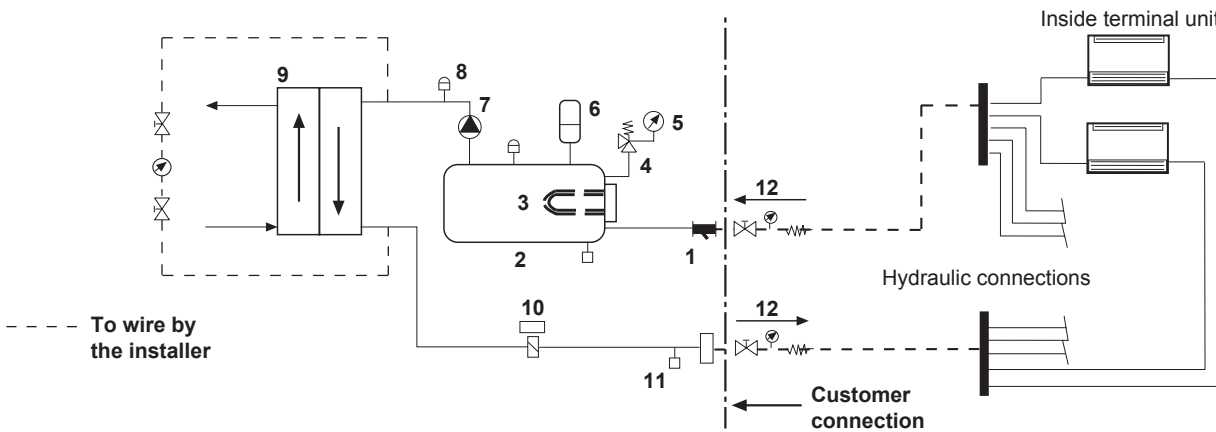

Models 1003SM to 1804SM

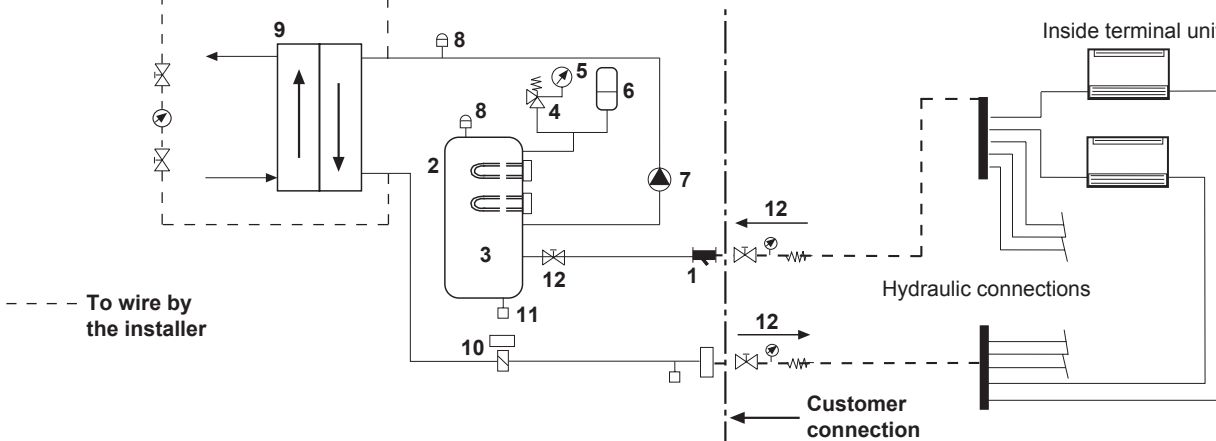

HYDRAULIC VERSION

Models 0251SM to 1804SM

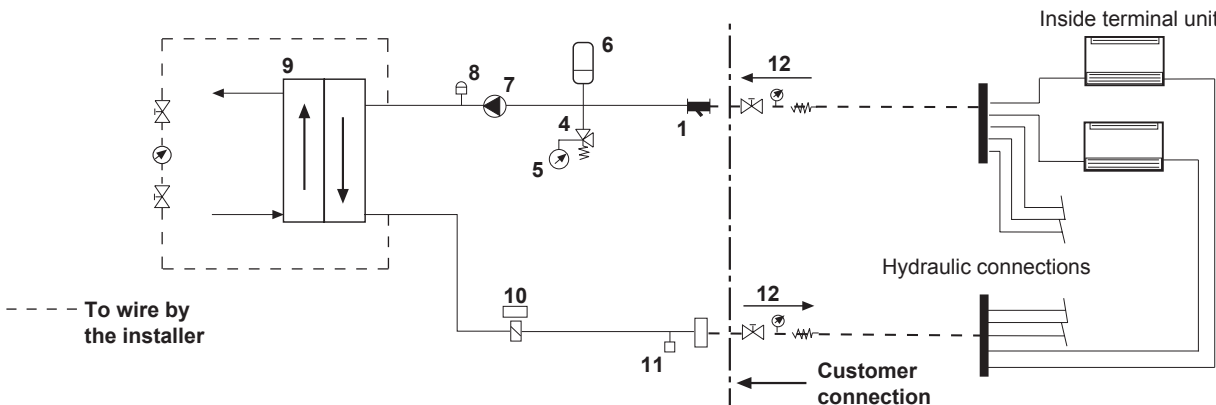

1.- GENERAL CHARACTERISTICS

1.4.- OPERATION LIMITS

STANDARD FAN UNITS WITHOUT AIR DUCTS

COOLING MODE	MODELS EAC / EAR	0251SM to 0431SM		0472SM to 0812SM		1003SM to 1804SM	
		MINIMUM	MAXIMUM	MINIMUM	MAXIMUM	MINIMUM	MAXIMUM
	Outlet chilled water temperature	+5°C	+14°C	+5°C	+14°C	+5°C	+14°C
	Inlet chilled water temperature	+10°C	+22°C	+9°C	+22°C	+8°C	+22°C
	Air inlet temperature	0°C (1)	+48°C	0°C(1)	+48°C	0°C(1)	+48°C

NOTE: With outdoor temperatures below +5°C, add glycol

(1) With the option cooling low ambient kit (-15°C), it is possible the unit operation down to -15°C in EAC units.

HEATING MODE	MODELS EAR	0251SM to 1804SM	
		MINIMUM	MAXIMUM
	Hot water outlet temperature (operation)	+20°C	+50°C
	Hot water inlet temperature (start)	+10°C	+43°C
	Difference hot water inlet / outlet	+3°C	+8°C
	Air inlet temperature	-10°C (2)	+23°C

OUTSIDE THESE VALUES, PLEASE CONSULT US

(2) With the option heating low ambient kit (-15°C), it is possible the unit operation down to -15°C

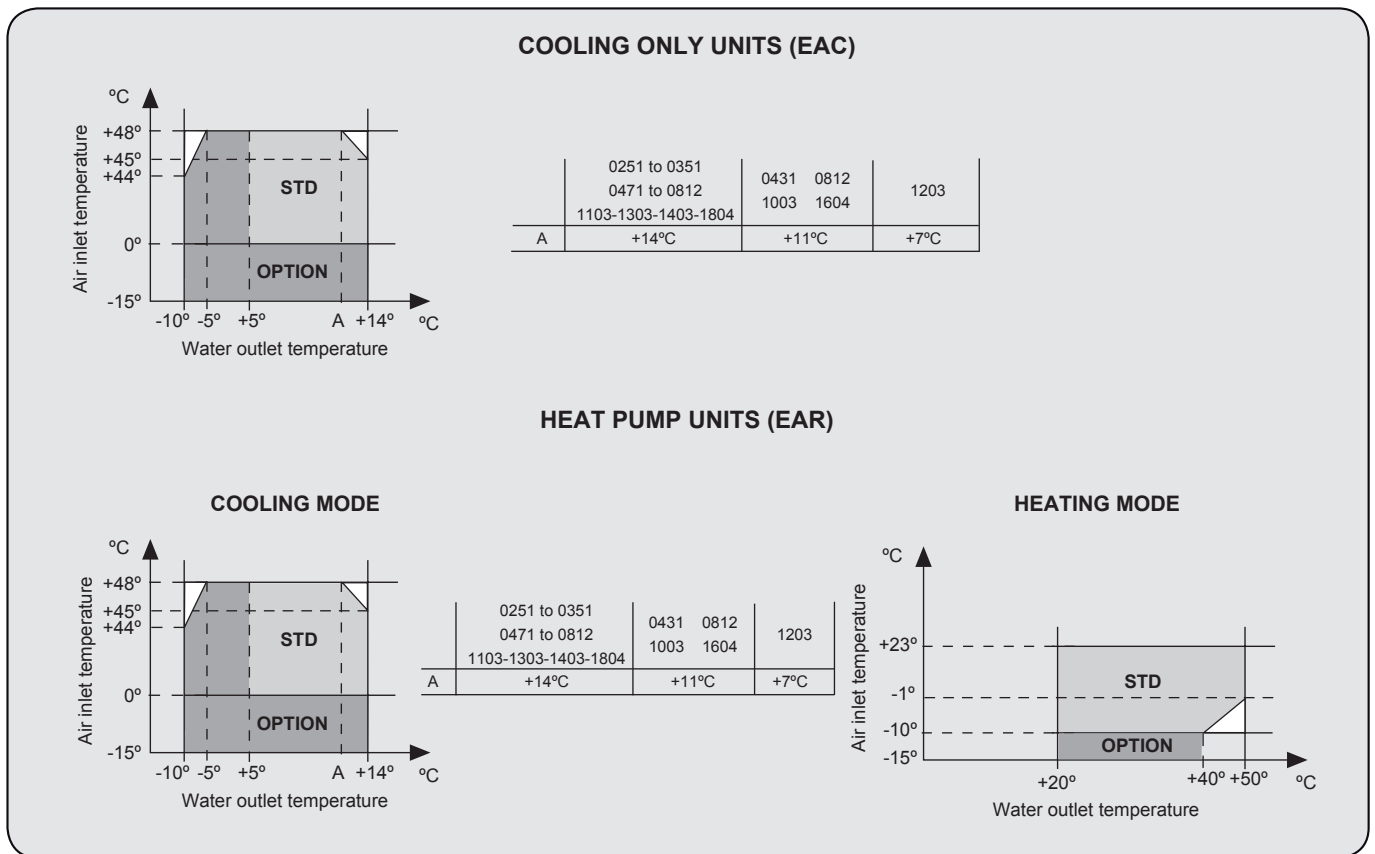

NOTE: With outdoor temperatures below +5°C, add glycol.

1.- GENERAL CHARACTERISTICS

1.4.- OPERATION LIMITS

FAN UNITS WITH AIR DUCTS

COOLING MODE

AIR AVAILABLE STATIC PRESSURE UP TO	VERSION	MODELS	Available static pressure Pa	Maximum ambient temperature °C	Minimum ambient temperature °C
	50Pa	STANDARD	0251SM to 1804SM	30	44
50				40	---
125Pa	FP1	0251SM to 1003SM	50	48	0°C (1)
			75	45	
			100	41	
			125	37	
		1103SM to 1804SM	50	46	0°C (1)
			75	43	
			100	39	
			125	37	
250 or 350Pa	FP2	0251SM to 0812SM	150	49	0°C
			200	46	
			250	43	
			300	40	
			350	37	
		1003SM to 1804SM	150	49	0°C (1)
			200	46	
			250	43	
			300	N/A	
			350	N/A	

HEATING MODE

AIR AVAILABLE STATIC PRESSURE UP TO	VERSION	MODELS	Available static pressure Pa	Minimum ambient temperature °C (2)
	50Pa	STANDARD	0251SM to 1804SM	30
50				-6
125Pa	FP1	0251SM to 1003SM	50	-10
			75	-8
			100	-6
			125	-5
250 or 350Pa	FP2	0251SM to 0812SM	150	-10
			200	-10
			250	-8
			300	-6
			350	-5
		1003SM to 1804SM	150	-10
			200	-10
			250	-8
			300	N/A
			350	N/A

N/A: Not available

(1) With the option cooling low ambient kit (-15°C), it is possible the unit operation down to -15°C

(2) With the option heating low ambient kit (-15°C), it is possible the unit operation down to -15°C.

UNITS WITH LOW WATER TEMPERATURE KIT (OPTION)

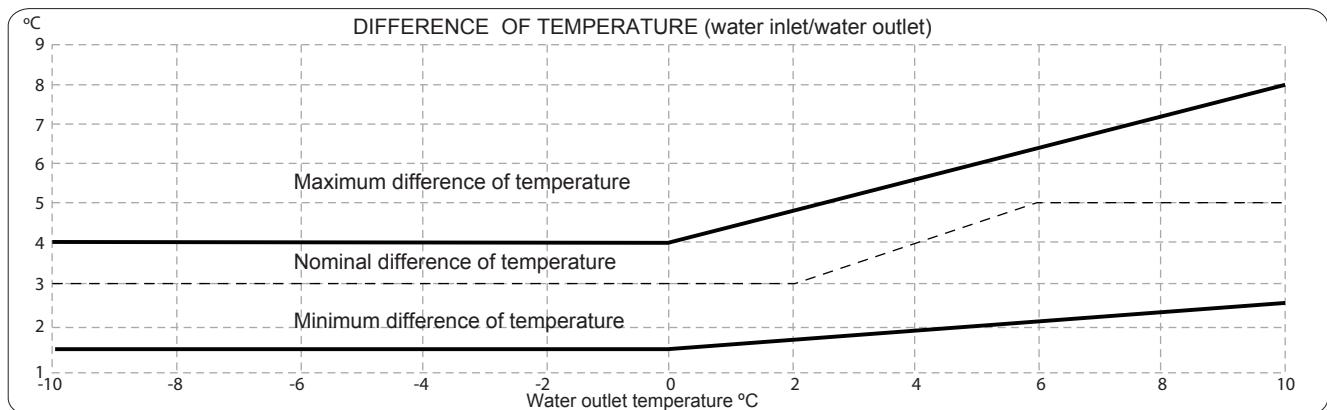

1.- GENERAL CHARACTERISTICS

1.5.- PRESSURE DROP IN THE WATER SYSTEM



INSTALLATION ADVISE

The units **MUST** be fitted with a water filter at the inlet to the unit (trapping any particles with a diameter greater than 1 mm.)

MODELS EAC / EAR 0251SM TO 0812SM

PRESSURE DROP WITHOUT FILTER

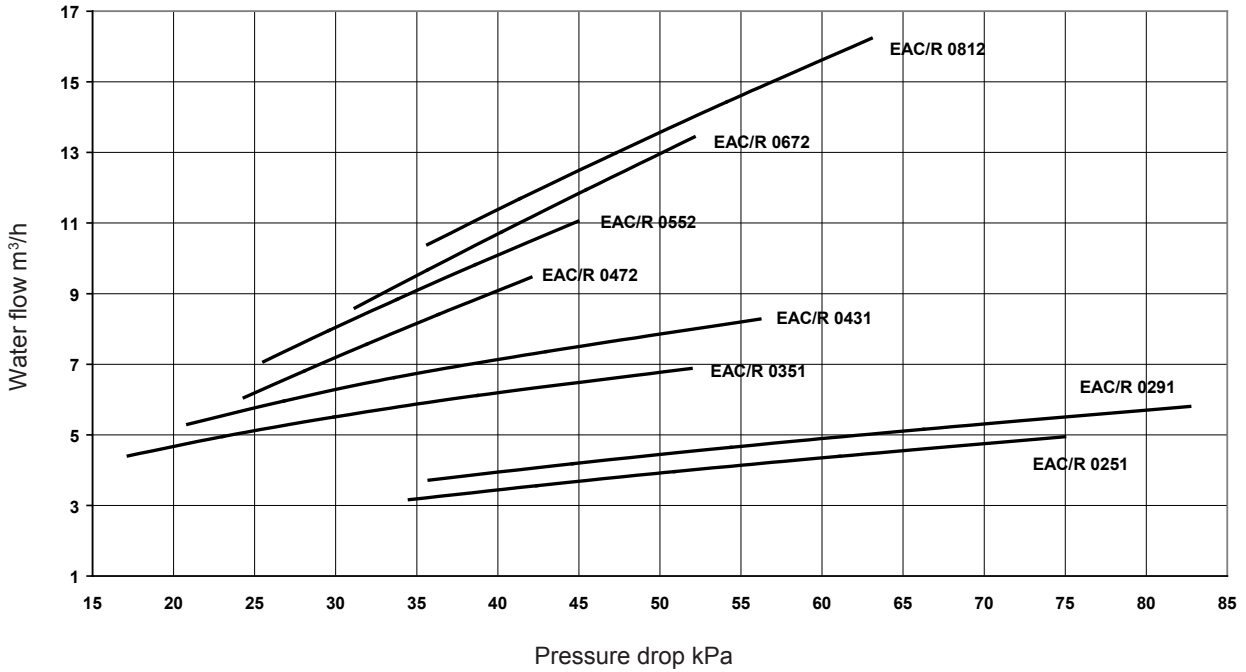

PRESSURE DROP + WATER FILTER (*)

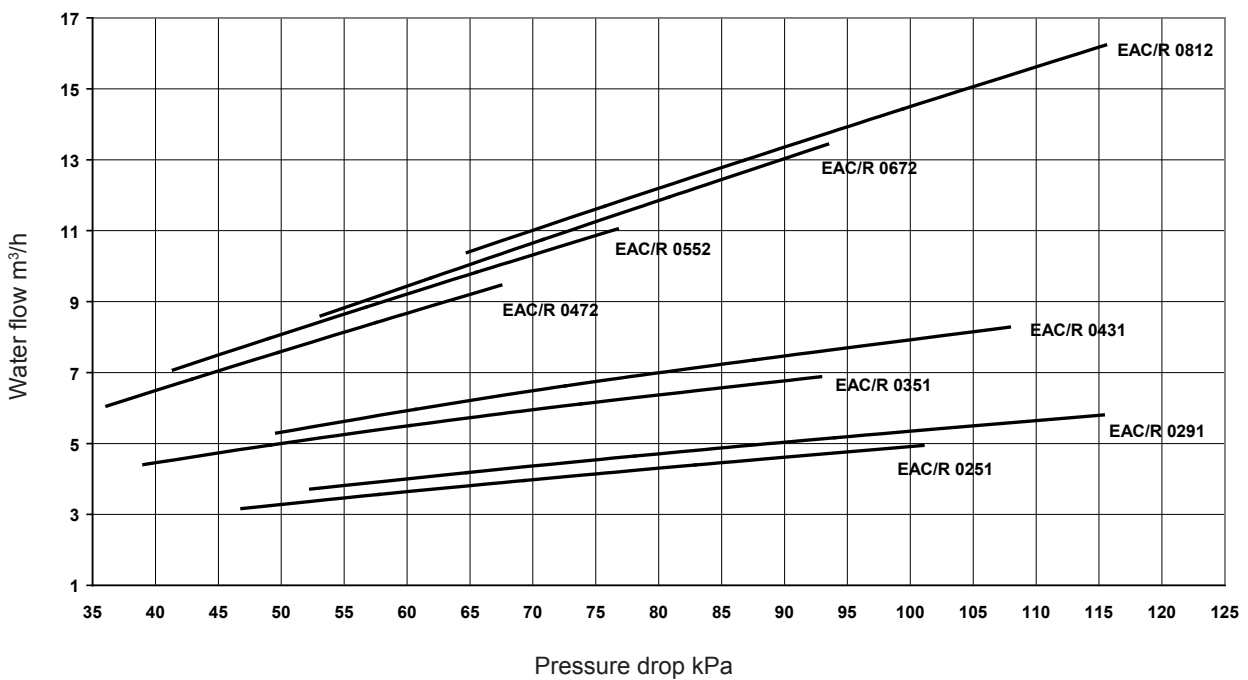

(*) Option in standard version, included in Hydronic and Hydraulic version.

1.- GENERAL CHARACTERISTICS

1.5.- PRESSURE DROP IN THE WATER SYSTEM



INSTALLATION ADVISE

The units **MUST** be fitted with a water filter at the inlet to the unit (trapping any particles with a diameter greater than 1 mm.)

MODELS EAC / EAR 1003SM TO 1804SM

PRESSURE DROP WITHOUT FILTER

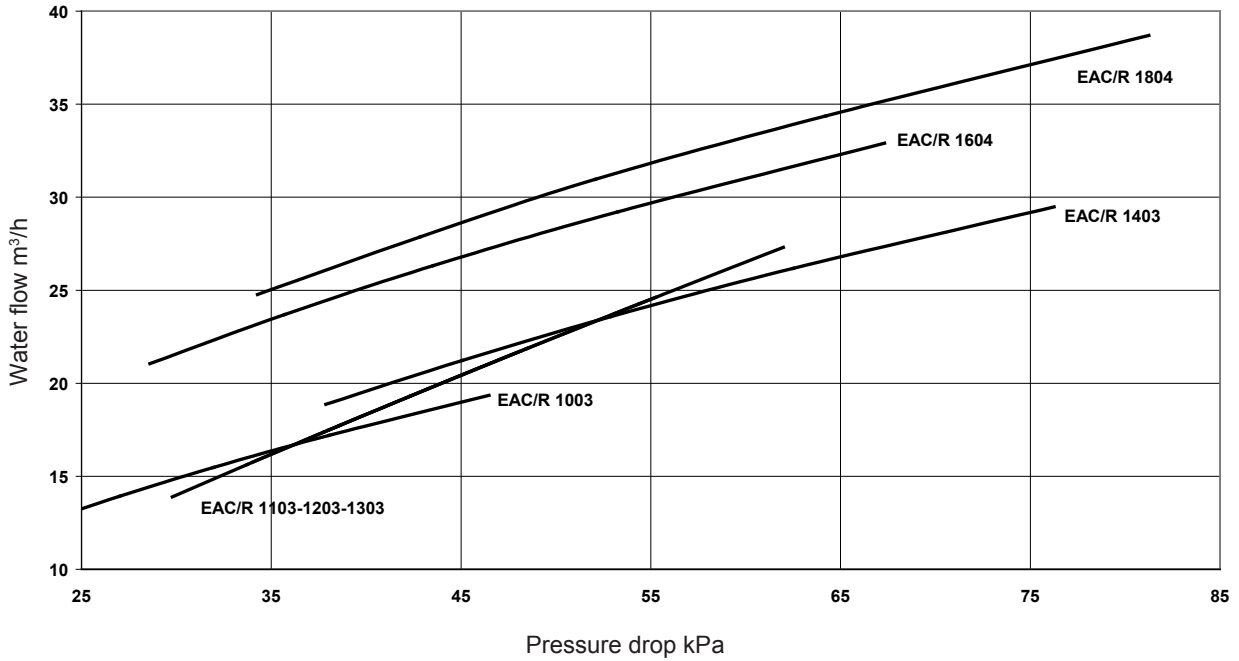

PRESSURE DROP + WATER FILTER (*)

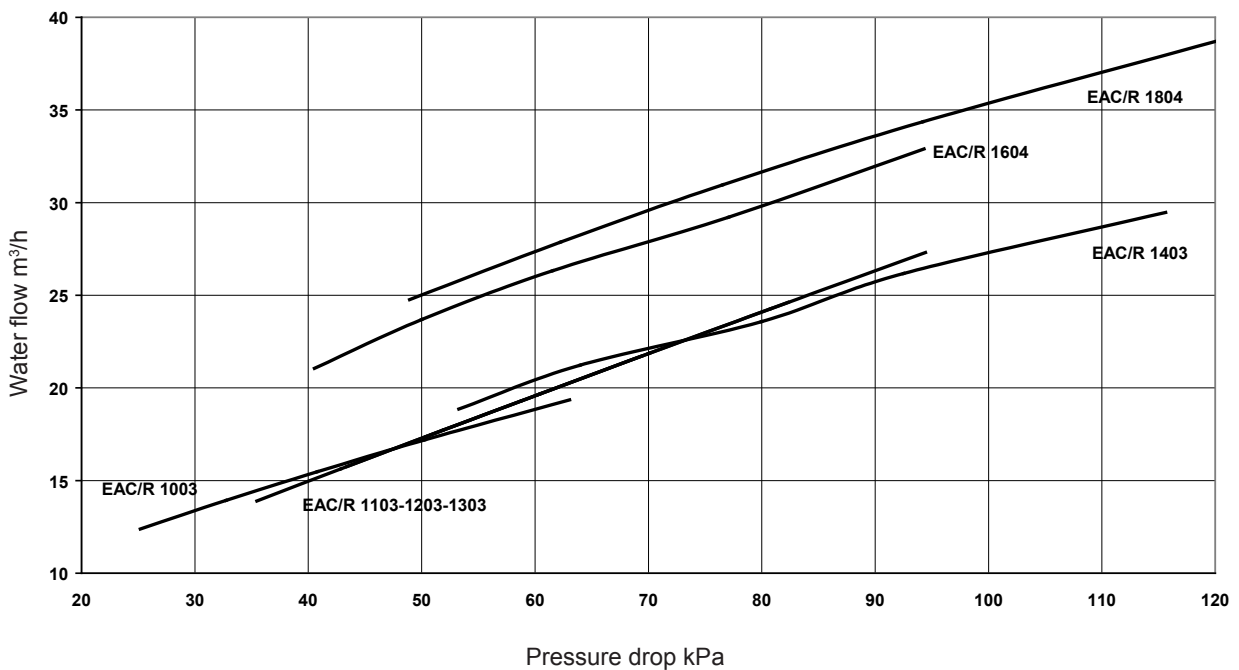

(*) Option in standard version, included in Hydronic and Hydraulic version.

1.- GENERAL CHARACTERISTICS

1.5.- HYDRAULIC SYSTEM DATA

WATER FLOW AND AVAILABLE STATIC PRESSURE (Factory supplied; standard water pump and filter).

MODELS		EAC / EAR 0251SM					EAC / EAR 0291SM					EAC / EAR 0351SM				
Water flow	l/s	0,88	0,99	1,06	1,22	1,37	1,03	1,16	1,24	1,43	1,61	1,22	1,38	1,53	1,70	1,91
	m ³ /h	3,16	3,56	3,80	4,40	4,95	3,72	4,18	4,45	5,16	5,81	4,40	4,95	5,50	6,12	6,88
Available static pressure	kPa	175	152	131	110	87	153	129	106	83	55	214	182	150	115	72

MODELS		EAC / EAR 0431SM				EAC / EAR 0472SM				EAC / EAR 0552SM					
Water flow	l/s	1,47	1,66	1,80	2,04	1,68	1,89	2,11	2,34	1,96	2,21	2,42	2,73	3,07	
	m ³ /h	5,30	5,96	6,47	7,36	6,05	6,81	7,59	8,41	7,07	7,96	8,72	9,82	11,05	
Available static pressure	kPa	161	132	96	47	156	141	128	115	101	140	128	115	99	78

MODELS		EAC / EAR 0672SM					EAC / EAR 0812SM				EAC / EAR 1003SM				
Water flow	l/s	2,39	2,69	3,03	3,32	3,73	2,89	3,25	3,60	4,01	3,44	3,87	4,21	4,78	5,38
	m ³ /h	8,60	9,68	10,90	11,94	13,44	10,39	11,69	12,98	14,43	12,38	13,93	15,17	17,20	19,35
Available static pressure	kPa	223	194	165	134	97	180	147	107	54	214	202	189	173	151

MODELS		EAC / EAR 1103SM					EAC / EAR 1203SM					EAC / EAR 1303SM				
Water flow	l/s	3,86	4,34	4,89	5,36	6,03	4,38	4,92	5,34	6,08	6,84	4,85	5,46	6,01	6,74	7,58
	m ³ /h	13,90	15,63	17,61	19,30	21,72	15,76	17,72	19,23	21,88	24,62	17,48	19,66	21,62	24,27	27,31
Available static pressure	kPa	200	186	172	155	132	185	169	151	130	102	171	152	131	106	71

MODELS		EAC / EAR 1403SM					EAC / EAR 1604SM					EAC / EAR 1804SM				
Water flow	l/s	5,24	5,90	6,63	7,27	8,19	5,85	6,58	7,13	8,12	9,14	6,88	7,74	8,31	9,55	10,75
	m ³ /h	18,86	21,22	23,87	26,17	29,48	21,06	23,69	25,66	29,22	32,90	24,77	27,86	29,93	34,37	38,70
Available static pressure	kPa	165	142	115	90	51	158	138	115	85	53	197	176	137	106	60

Nominal conditions

NOTE: The flow data indicated in table are between a minimum and a maximum water flow.
With the twin pumps kit, the available static pressure will decrease 5% from the data shown above.

Unit conversion: Pressure 1KPa = 1/9,8 m.c.a. = 0,01 bar
1 bar = 10 m.c.a. = 100 kPa

MINIMUM WATER FLOW

The installation must never operate with less than the minimum water flow (see table above), this will cause:

- i. - Freezing the water heat exchanger.
- ii. - Contamination of the heat exchanger.

MAXIMUM WATER FLOW

See maximum water flow, (see table above). Always assure the minimum ΔT to the exchanger of 3°C.

MAXIMUM WATER VOLUME IN THE INSTALLATION

The units with Hydronic or Hydraulic module include a expansion vessel.
The table below details the maximum water volume in the system.

MODELS	0251SM to 0431SM	0472SM to 0812SM	1003SM to 1403SM	1604SM 1804SM
SOLUTION	Water volume in liters			
WATER	550	850	1600	2250
WATER + 10% GYT	400	650	1225	1725
WATER + 20% GYT	350	475	1075	1500
WATER + 30% GYT	300	450	925	1300
WATER + 35% GYT	225	325	700	1000

If the water volume in the system is greater than that detailed in the table it will be necessary to add additional expansion vessel(s). The system design must allow for water expansion and contraction.

1.- GENERAL CHARACTERISTICS

1.7.- SAFETY DEVICES

0251SM TO 0812SM UNITS

COOLING ONLY

COOLING EAC	1 F			2 F			3 F			4 F			5 F			6 F = 2F + 3F			7 F = 2F + 4F			8 F = 2F + 5F					
	UNIT STD/FP1			UNIT FP2			KIT LOW WATER T ^a 0°C (STD/FP1)			KIT LOW WATER T ^a -5°C (STD/FP1)			KIT LOW WATER T ^a -10°C (STD/FP1)			KIT LOW WATER T ^a 0°C (FP2)			KIT LOW WATER T ^a -5°C (FP2)			KIT LOW WATER T ^a -10°C (FP2)					
	cycle	set	reset	cycle	set	reset	cycle	set	reset	cycle	set	reset	cycle	set	reset	cycle	set	reset	cycle	set	reset	cycle	set	reset			
LP1	cooling	4,5	6	cooling	4,5	6	cooling	4,5	6	cooling	3,5	4,5	cooling	2,5	3,5	cooling	4,5	6	cooling	3,5	4,5	cooling	2,5	3,5			
HP1	cooling	43	34	cooling	43	34	cooling	43	34	cooling	43	34	cooling	43	34	cooling	43	34	cooling	43	34	cooling	43	34			
PT1	N/A			N/A			N/A			N/A			N/A			N/A			N/A			N/A					
HPR	N/A			cooling	22	28	N/A			N/A			N/A			cooling	22	28	N/A			cooling	22	28	cooling	22	28
B2	(*)			(*)			(*)			(*)			(*)			(*)			(*)			(*)					
B3	(*)			(*)			(*)			(*)			(*)			(*)			(*)			(*)					

COOLING EAC	9 F			10 F			11 F			12 F		
	COOLING LOW AMBIENT KIT -15°C (STD/FP1/FP2)			KIT LOW WATER T ^a 0°C COOLING -15°C (STD/FP1/FP2)			KIT LOW WATER T ^a -5°C COOLING -15°C (STD/FP1/FP2)			KIT LOW WATER T ^a -10°C COOLING -15°C (STD/FP1/FP2)		
	cycle	set	reset	cycle	set	reset	cycle	set	reset	cycle	set	reset
LP1	cooling	3,5	4,5	cooling	3,5	4,5	cooling	3,5	4,5	cooling	2,5	3,5
HP1	cooling	43	34	cooling	43	34	cooling	43	34	cooling	43	34
PT1	(*)			(*)			(*)			(*)		
HPR	N/A			N/A			N/A			N/A		
B2	(*)			(*)			(*)			(*)		
B3	N/A			N/A			N/A			N/A		

HEAT PUMP

HEATING EAR	1 B			2 B			3 B			4 B			5 B			6 B = 2B + 5B			7 B = 3B + 5B			8 B = 4B + 5B		
	UNIT STD/FP1/FP2			KIT LOW WATER T ^a 0°C (STD/FP1/FP2)			KIT LOW WATER T ^a -5°C (STD/FP1/FP2)			KIT LOW WATER T ^a -10°C (STD/FP1/FP2)			HEATING LOW AMBIENT KIT -15°C (STD/FP1/FP2)			KIT LOW WATER T ^a 0°C HEATING -15°C (STD/FP1/FP2)			KIT LOW WATER T ^a -5°C HEATING -15°C (STD/FP1/FP2)			KIT LOW WATER T ^a -10°C HEATING -15°C (STD/FP1/FP2)		
	cycle	set	reset	cycle	set	reset	cycle	set	reset	cycle	set	reset	cycle	set	reset	cycle	set	reset	cycle	set	reset	cycle	set	reset
LP1	cooling	4,5	6	cooling	4,5	6	cooling	3,5	4,5	cooling	2,5	3,5	cooling	4,5	6	cooling	4,5	6	cooling	3,5	4,5	cooling	2,5	3,5
PT1	heating	1,7	2,7	heating	1,7	2,7	heating	1,7	2,7	heating	1,7	2,7	heating	1,7	2,7	heating	1,7	2,7	heating	1,7	2,7	heating	1,7	2,7
HP1	c/h	43	34	c/h	43	34	c/h	43	34	c/h	43	34	c/h	43	34	c/h	43	34	c/h	43	34	c/h	43	34
PT1	(*)			(*)			(*)			(*)			(*)			(*)			(*)			(*)		
DT	N/A			N/A			N/A			N/A			heating	118°C differential 7	heating	118°C differential 7	heating	118°C differential 7	heating	118°C differential 7	heating	118°C differential 7		
B2	(*)			(*)			(*)			(*)			(*)			(*)			(*)			(*)		

LP / HP / PT / HPR values in Bar. B values in °C.

(*) CLIMATIC 40 REGULATION

1.-FAN SPEED REGULATION (B36 PT1)

EAC_(1 and 2) EAR_(Cooling) STD/FP1

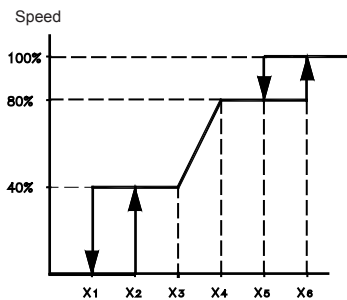

MOD.	Unit	X1	X2	X3	X4	X5	X6
EAC (1)	°C	18	18,1	28	35	39,1	40
EAC (2)	Bar	18	19	20	24	25	26
EAR (Cooling)	Bar	18	19	20	24	25	26

(1) Without PT1

(2) With PT1

EAC₍₂₎ EAR_(Cooling) FP2

Fan start-up 28 Bar
Cut-off 22 Bar

2.-DEFROST CYCLE (PT1)

Start 5,7 Bar
End 35 Bar

3.-ALARMS

ANTIFREEZE ALARM (B2)

	CUT	RESET
STD Unit	+3°C	+8°C
Low water T ^a option 0°C	-3°C	-4°C
Low water T ^a option -10°C	-8°C	-7°C
Low water T ^a option -15°C	-13°C	-12°C

1.- GENERAL CHARACTERISTICS

1.7.- SAFETY DEVICES

1003SM TO 1804SM UNITS

COOLING ONLY

COOLING EAC	1 F			2 F			3 F			4 F			5 F			6 F		
	UNIT STD/FP1/FP2			KIT LOW WATER T ^a 0°C (STD/FP1/FP2)			KIT LOW WATER T ^a -5°C (STD/FP1/FP2)			KIT LOW WATER T ^a -10°C (STD/FP1/FP2)			COOLING LOW AMBIENT KIT -15°C (STD)			COOLING LOW AMBIENT KIT -15°C (FP1/FP2)		
	cycle	set	reset	cycle	set	reset	cycle	set	reset	cycle	set	reset	cycle	set	reset	cycle	set	reset
LP1	cooling	4,5	6	cooling	4,5	6	cooling	3,5	4,5	cooling	2,5	3,5	cooling	3,5	4,5	cooling	3,5	4,5
LP2	cooling	4,5	6	cooling	4,5	6	cooling	3,5	4,5	cooling	2,5	3,5	cooling	3,5	4,5	cooling	3,5	4,5
HP1	cooling	43	34	cooling	43	34	cooling	43	34	cooling	43	34	cooling	43	34	cooling	43	34
HP2	cooling	43	34	cooling	43	34	cooling	43	34	cooling	43	34	cooling	43	34	cooling	43	34
HPR11	cooling	22	28	cooling	22	28	cooling	22	28	cooling	22	28	FSC (6A)			FSC1 (12A/20A)		
HPR12	cooling	37	30	cooling	37	30	cooling	37	30	cooling	37	30						
HPR21	cooling	22	28	cooling	22	28	cooling	22	28	cooling	22	28	FSC2 (6A)			FSC2 (12A/20A)		
HPR22	cooling	37	30	cooling	37	30	cooling	37	30	cooling	37	30						
PT1/PT2	N/A			N/A			N/A			N/A			(*)			(*)		
B2	(*)			(*)			(*)			(*)			(*)			(*)		

COOLING EAC	7 F = 2F + 5F			8 F = 3F + 5F			9 F = 4F + 5F		
	KIT LOW WATER T ^a 0°C COOLING -15°C (STD)			KIT LOW WATER T ^a -5°C COOLING -15°C (STD)			KIT LOW WATER T ^a -10°C COOLING -15°C (STD)		
	cycle	set	reset	cycle	set	reset	cycle	set	reset
LP1	cooling	3,5	4,5	cooling	3,5	4,5	cooling	2,5	3,5
LP2	cooling	3,5	4,5	cooling	3,5	4,5	cooling	2,5	3,5
HP1	cooling	43	34	cooling	43	34	cooling	43	34
HP2	cooling	43	34	cooling	43	34	cooling	43	34
HPR11	FSC1 (6A)			FSC1 (6A)			FSC1 (6A)		
HPR12									
HPR21	FSC2 (6A)			FSC2 (6A)			FSC2 (6A)		
HPR22									
PT1/PT2	(*)			(*)			(*)		
B2	(*)			(*)			(*)		

COOLING EAC	10F = 2F + 6F			11 F = 3F + 6F			12 F = 4F + 6F		
	KIT LOW WATER T ^a 0°C COOLING -15°C (FP1/FP2)			KIT LOW WATER T ^a -5°C COOLING -15°C (FP1/FP2)			KIT LOW WATER T ^a -10°C COOLING -15°C (FP1/FP2)		
	cycle	set	reset	cycle	set	reset	cycle	set	reset
LP1	cooling	3,5	4,5	cooling	3,5	4,5	cooling	2,5	3,5
LP2	cooling	3,5	4,5	cooling	3,5	4,5	cooling	3,5	4,5
HP1	cooling	43	34	cooling	43	34	cooling	43	34
HP2	cooling	43	34	cooling	43	34	cooling	43	34
HPR11	FSC1 (12A/20A)			FSC1 (12A/20A)			FSC1 (12A/20A)		
HPR12									
HPR21	FSC2 (12A/20A)			FSC2 (12A/20A)			FSC2 (12A/20A)		
HPR22									
PT1/PT2	(*)			(*)			(*)		
B2	(*)			(*)			(*)		

(*) CLIMATIC 40 REGULATION

1.-FAN SPEED REGULATION (PT1 y PT2)

EAR STD/FP1/FP2
 -Fan start-up 28 Bar
 -Cut off 22 Bar

2.-DEFROST CYCLE (PT1 y PT2)

-Start 5,7 Bar
 -End 35 Bar

3.-ALARMS

ANTIFREEZE ALARM (B2)

	CUT	RESET
STD Unit	+3°C	+8°C
Low water T ^a option 0°C	-3°C	-2°C
Low water T ^a option -10°C	-8°C	-7°C
Low water T ^a option -15°C	-13°C	-12°C

(*) FAN SPEED REGULATION WITH PROPORTIONAL CONDENSING PRESSURE CONTROL (FSC/FSC1/FSC2) (PT1/PT2)

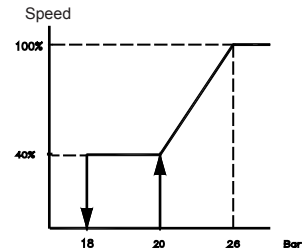

LP / HP / PT / HPR values in Bar. B values in °C.

1.- GENERAL CHARACTERISTICS

1.7.- SAFETY DEVICES

1003SM TO 1804SM UNITS

HEAT PUMP

HEATING EAR	1 B			2 B			3 B			4 B			5 B			6 B = 2B + 5B			7 B = 3B + 5B			8 B = 4B + 5B				
	UNIT STD/FP1/FP2			KIT LOW WATER T ^a 0°C (STD/FP1/FP2)			KIT LOW WATER T ^a -5°C (STD/FP1/FP2)			KIT LOW WATER T ^a -10°C (STD/FP1/FP2)			HEATING LOW AMBIENT KIT -15°C (STD/FP1/FP2)			KIT LOW WATER T ^a 0°C HEATING -15°C (STD/FP1/FP2)			KIT LOW WATER T ^a -5°C HEATING -15°C (STD/FP1/FP2)			KIT LOW WATER T ^a -10°C HEATING -15°C (STD/FP1/FP2)				
	cycle	set	reset	cycle	set	reset	cycle	set	reset	cycle	set	reset	cycle	set	reset	cycle	set	reset	cycle	set	reset	cycle	set	reset	cycle	set
LP1	cooling	4,5	6	cooling	4,5	6	cooling	3,5	4,5	cooling	2,5	3,5	cooling	4,5	6	cooling	4,5	6	cooling	3,5	4,5	cooling	2,5	3,5		
PT1	heating	1,7	2,7	heating	1,7	2,7	heating	1,7	2,7	heating	1,7	2,7	heating	1,7	2,7	heating	1,7	2,7	heating	1,7	2,7	heating	1,7	2,7		
LP2	cooling	4,5	6	cooling	4,5	6	cooling	3,5	4,5	cooling	2,5	3,5	cooling	4,5	6	cooling	4,5	6	cooling	3,5	4,5	cooling	2,5	3,5		
PT2	heating	1,7	2,7	heating	1,7	2,7	heating	1,7	2,7	heating	1,7	2,7	heating	1,7	2,7	heating	1,7	2,7	heating	1,7	2,7	heating	1,7	2,7		
HP1	c/h	43	34	c/h	43	34	c/h	43	34	c/h	43	34	c/h	43	34	c/h	43	34	c/h	43	34	c/h	43	34		
HP2	c/h	43	34	c/h	43	34	c/h	43	34	c/h	43	34	c/h	43	34	c/h	43	34	c/h	43	34	c/h	43	34		
HPR12	cooling	37	30	cooling	37	30	cooling	37	30	cooling	37	30	cooling	37	30	cooling	37	30	cooling	37	30	cooling	37	30		
PT1/PT2	(*)			(*)			(*)			(*)			(*)			(*)			(*)			(*)				
HPR22	cooling	37	30	cooling	37	30	cooling	37	30	cooling	37	30	cooling	37	30	cooling	37	30	cooling	37	30	cooling	37	30		
OT1	heating	6°C differential 2,3		heating	6°C differential 2,3		heating	6°C differential 2,3		heating	6°C differential 2,3		heating	6°C differential 2,3		heating	6°C differential 2,3		heating	6°C differential 2,3		heating	6°C differential 2,3			
DT	N/A			N/A			N/A			N/A			heating	118°C differential 7		heating	118°C differential 7		heating	118°C differential 7		heating	118°C differential 7			
B2	(*)			(*)			(*)			(*)			(*)			(*)			(*)			(*)				

LP / HP / PT / HPR values in Bar. B values in °C.

(*) CLIMATIC 40 REGULATION

1.-FAN SPEED REGULATION (PT1 y PT2)

EAR STD/FP1/FP2

- Fan start-up 28 Bar
- Cut off 22 Bar

2.-DEFROST CYCLE (PT1 y PT2)

- Start 5,7 Bar
- End 35 Bar

3.-ALARMS

ANTIFREEZE ALARM (B2)

	CUT	RESET
STD Unit	+3°C	+8°C
Low water T ^a option 0°C	-3°C	-2°C
Low water T ^a option -10°C	-8°C	-7°C
Low water T ^a option -15°C	-13°C	-12°C

(*) FAN SPEED REGULATION WITH PROPORTIONAL CONDENSING PRESSURE CONTROL (FSC/FSC1/FSC2) (PT1/PT2)

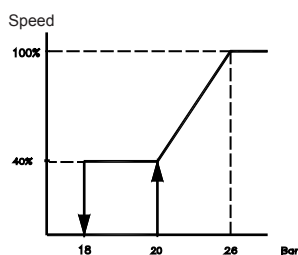







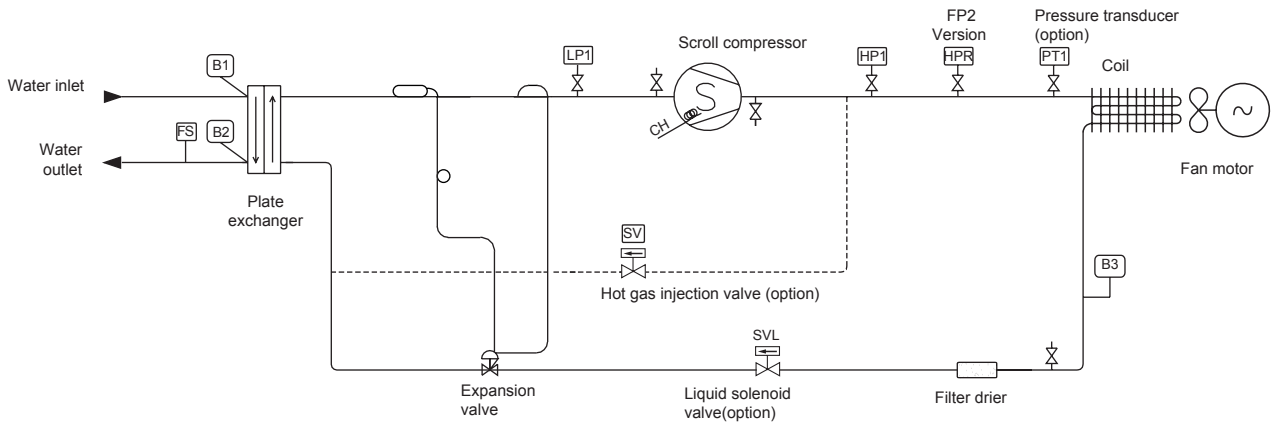



1.- GENERAL CHARACTERISTICS

1.8.- PIPING DRAWINGS

COOLING ONLY UNITS EAC 0251SM TO 0431SM



-  Pressure gauge
-  Flow switch (option in standard version)
-  Water inlet probe (water inlet regulation)
-  Water outlet probe (anti-freeze protection)
-  Piping probe (fan speed regulation)
-  Low pressure switch
-  High pressure switch
-  Fan speed pressure switch FP2 (versión FP2)
-  Crank case heater
-  Pressure transducer (low ambient temperature -15°C (option))
-  Liquid solenoid valve (low ambient temperature -15°C (option))

COOLING ONLY UNITS EAC 0472SM TO 0812SM

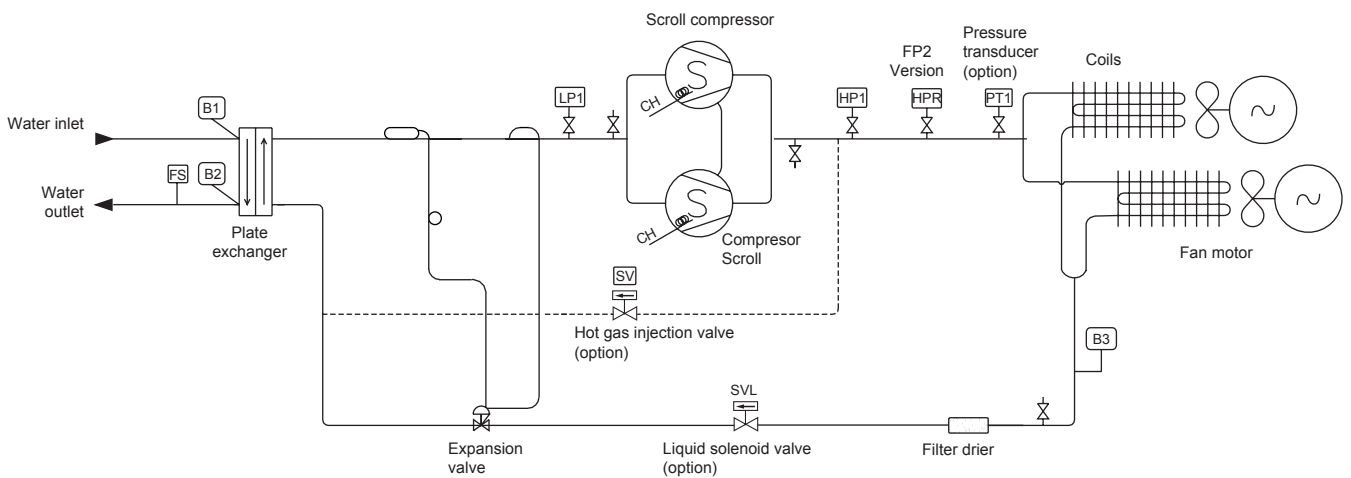

1.- GENERAL CHARACTERISTICS

1.8.- PIPING DRAWINGS

COOLING ONLY UNITS EAC 1003SM TO 1403SM

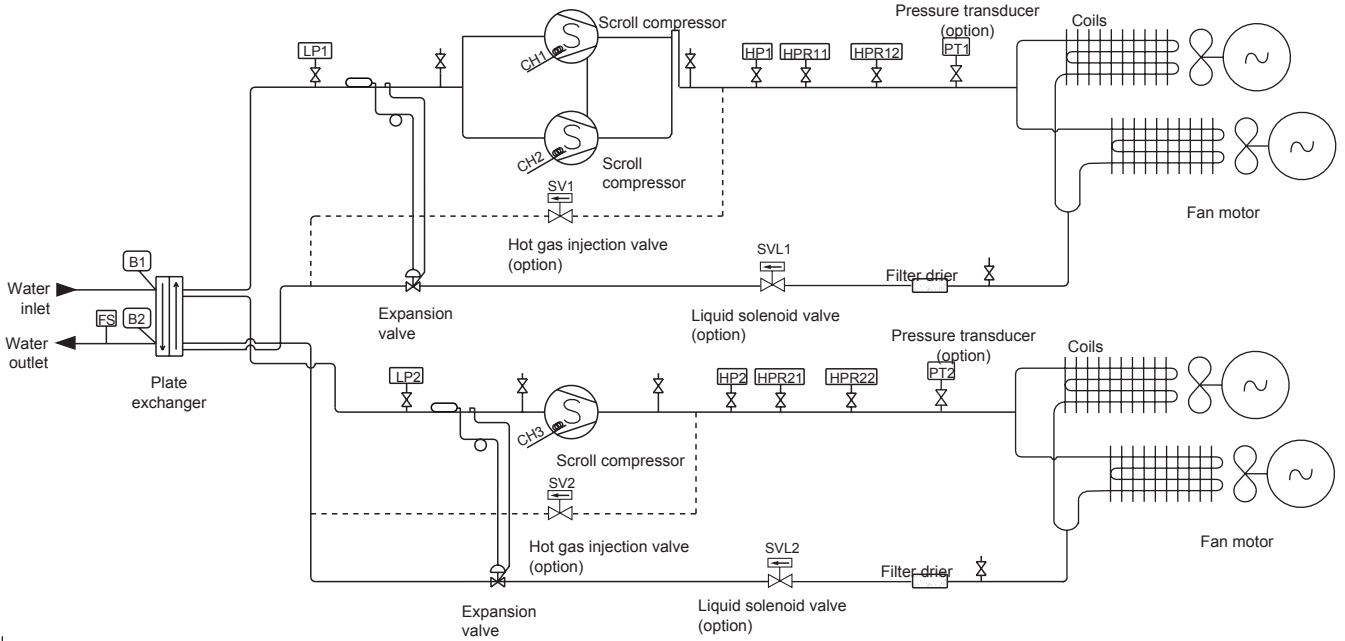

- Pressure gauge
- Flow switch (option in standard version)
- Water inlet probe (water inlet regulation)
- Water outlet probe (anti-freeze protection)
- Low pressure switch circuit 1
- Low pressure switch circuit 2
- High pressure switch circuit 1
- High pressure switch circuit 2
- Condensing pressure control ON/OFF fan motor

- Condensing pressure control. Low/high speed
- Condensing pressure control ON/OFF fan motor
- Condensing pressure control. Low/high speed
- Crank case heater
- Crank case heater
- Crank case heater
- Crank case heater
- Pressure transducer (low ambient temperature -15°C (option)) circuit 1.
- Pressure transducer (low ambient temperature -15°C (option)) circuit 2.
- Liquid solenoid valve (low ambient temperature -15°C (option)) circuit 1.
- Liquid solenoid valve (low ambient temperature -15°C (option)) circuit 2.

COOLING ONLY UNITS EAC 1604SM - 1804SM

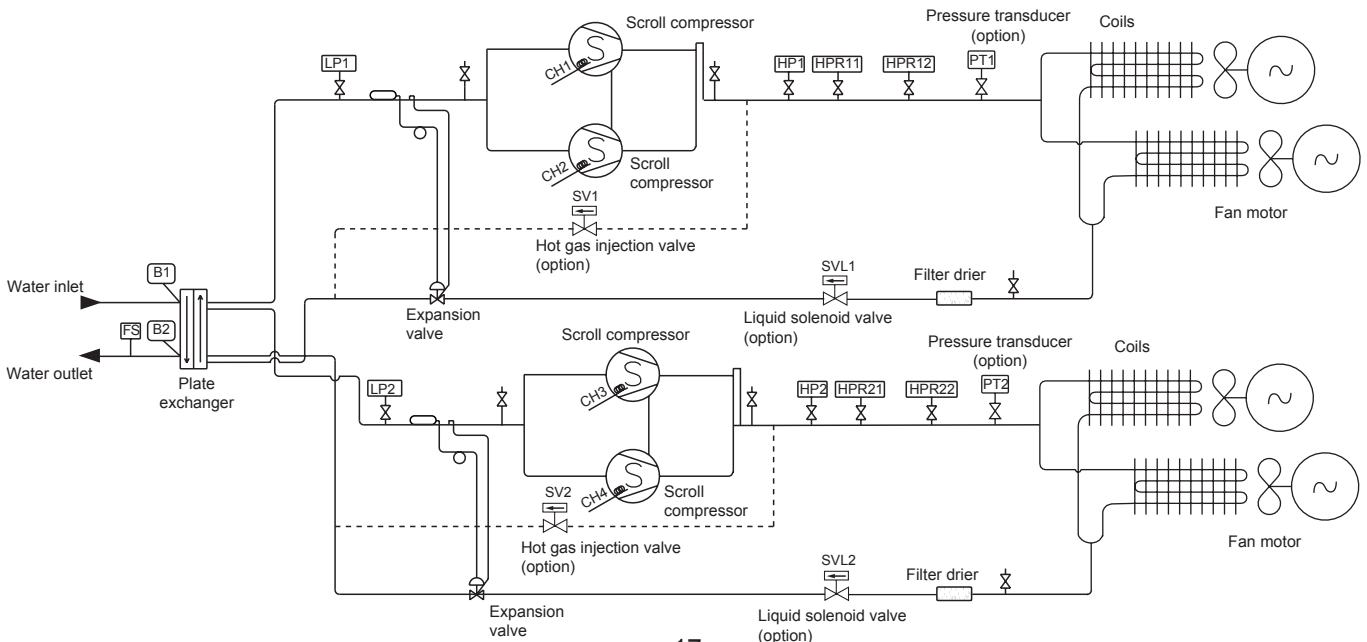

1.- GENERAL CHARACTERISTICS

1.8.- PIPING DRAWINGS

HEAT PUMP UNITS EAR 0251SM TO 0431SM

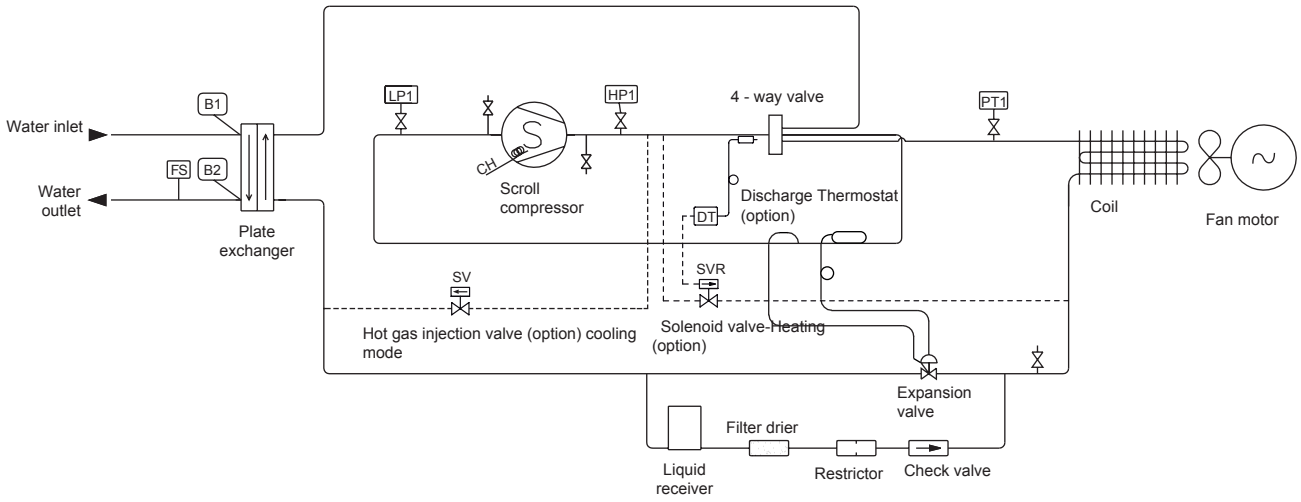

- Pressure gauge
- Flow switch (option in standard version)
- Water inlet probe (water inlet regulation)
- Water outlet probe (anti-freeze protection)
- Low pressure switch cooling cycle
- High pressure switch
- Crank case heater
- Pressure transducer:
 - Cooling: Condensing pressure control
 - Heat pump: Defrost start
 - Defrost end
 - Low pressure switch heating cycle
- Discharge Thermostat (Heating low ambient kit -15°C option)
- Solenoid valve (Heating low ambient kit -15°C option)

HEAT PUMP UNITS EAR 0472SM TO 0812SM

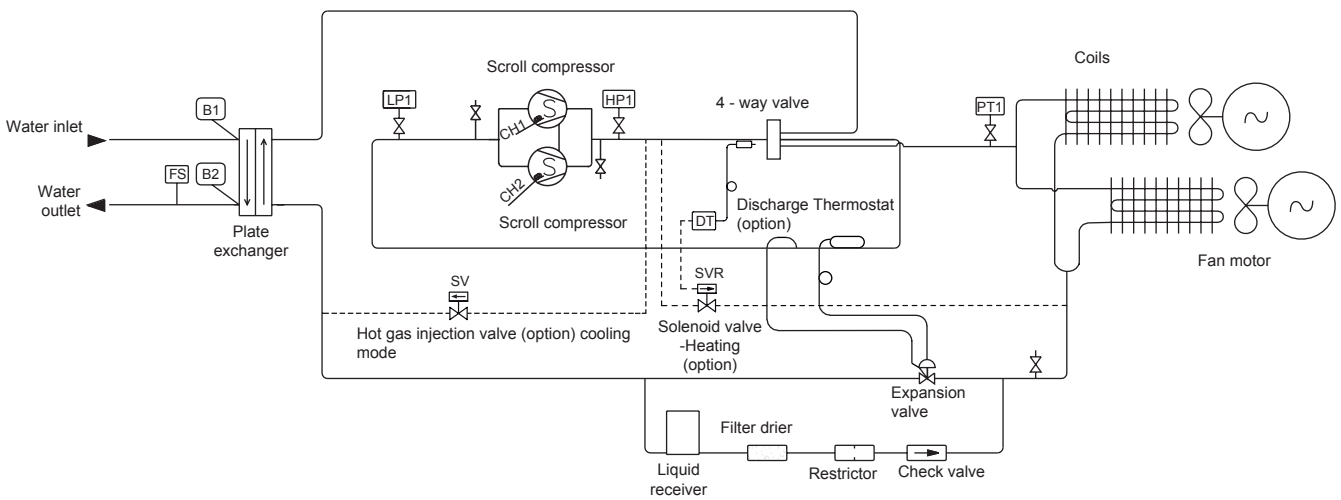

1.- GENERAL CHARACTERISTICS

1.8.- PIPING DRAWINGS

HEAT PUMP UNITS EAR 1003SM TO 1403SM

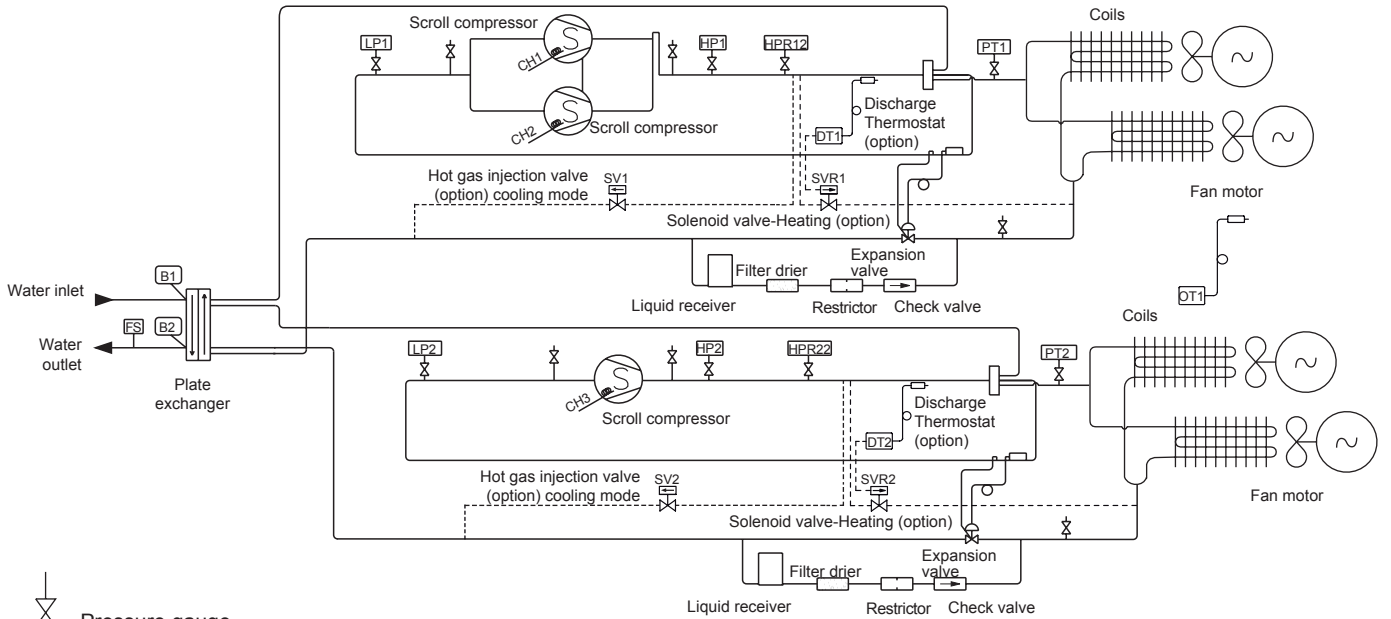

Pressure gauge

Flow switch (option in standard version)

Water inlet probe (water inlet regulation)

Water outlet probe (anti-freeze protection)

Crank case heater

Crank case heater

Crank case heater

Crank case heater

High pressure switch circuit 1

High pressure switch circuit 2

Condensing pressure control. Low/high speed Circuit 1

Condensing pressure control. Low/high speed Circuit 2

Low pressure switch cooling cycle circuit 1

Low pressure switch cooling cycle circuit 2

Pressure transducer circuit 1:

-Cooling: Condensing pressure control

-Heat pump: Defrost start

Defrost end Low pressure switch heating cycle circuit 1

Pressure transducer circuit 2:

-Cooling: Condensing pressure control

-Heat pump: Defrost start

Defrost end Low pressure switch heating cycle circuit 2

Discharge Thermostat (Heating low ambient kit -15°C option)

Discharge Thermostat (Heating low ambient kit -15°C option)

Solenoid valve circuit 1 (Heating low ambient kit -15°C option)

Solenoid valve circuit 12 (Heating low ambient kit -15°C option)

Fan speed thermostat (Heating)

HEAT PUMP UNITS EAR 1604SM TO 1804SM

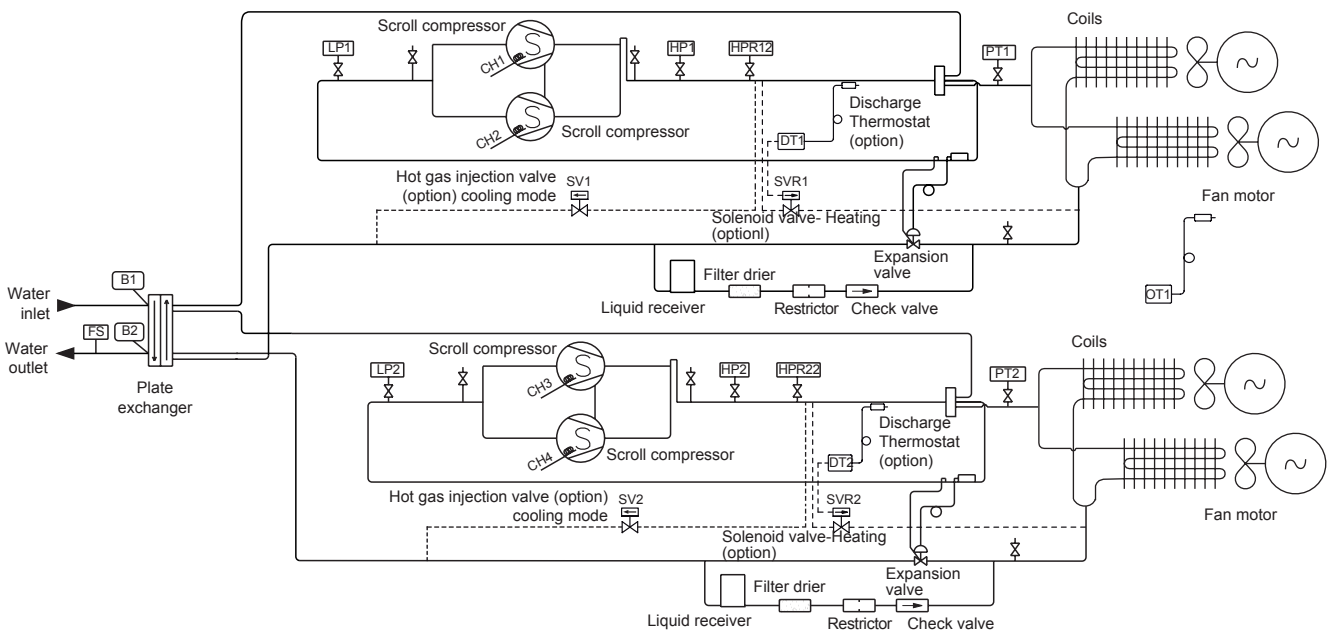

1.- GENERAL CHARACTERISTICS

1.9.- DIMENSIONS

EAC/EAR 0251SM-0291SM-0351SM-0431SM

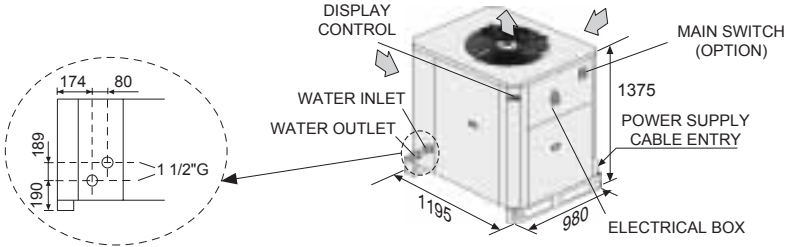

EAC/EAR 0251SM-0291SM-0351SM-0431SM FP1/FP2

	A	ØB
FP1 Version	240	630
FP2 Version	425	710

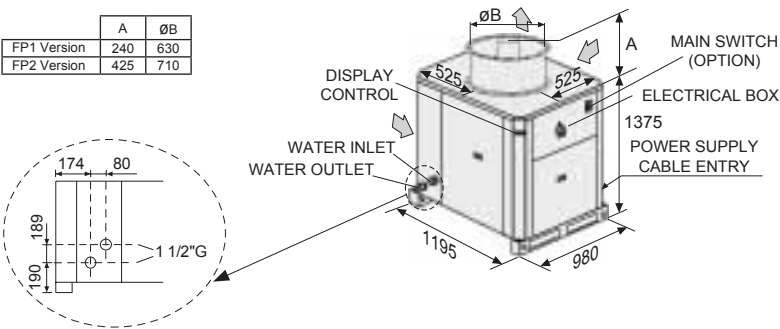

EAC/EAR 0472SM-0552SM-0672SM-0812SM

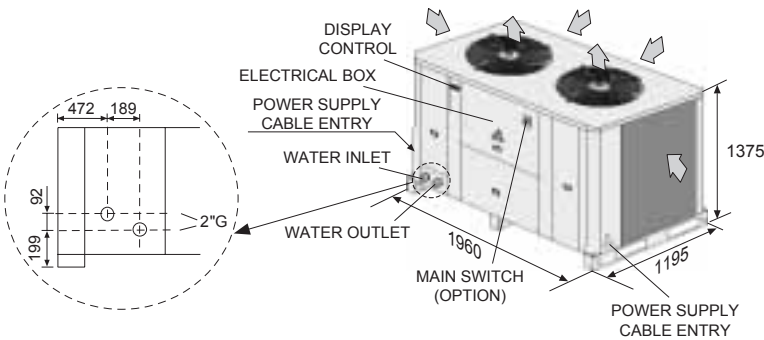

EAC/EAR 0472SM-0552SM-0672SM-0812SM FP1/FP2

	A	ØB
FP1 Version	240	630
FP2 Version	425	710

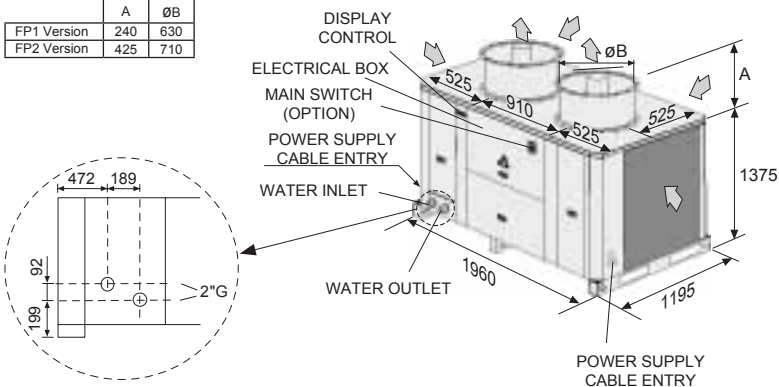

COMPONENT POSITION STANDARD VERSION UNIT

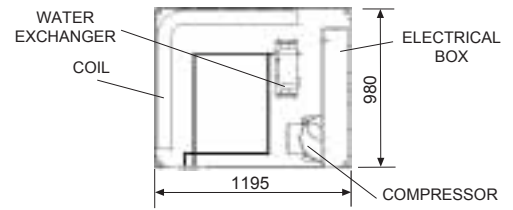

COMPONENT POSITION HYDRAULIC VERSION UNIT

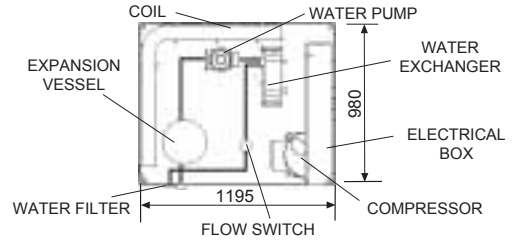

COMPONENT POSITION HYDRONIC VERSION UNIT

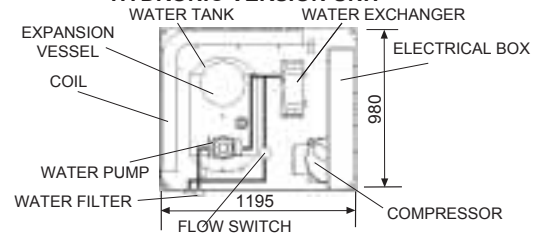

COMPONENT POSITION STANDARD VERSION UNIT

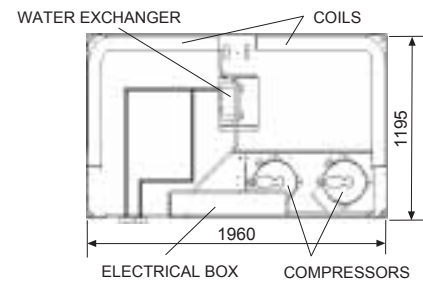

COMPONENT POSITION HYDRAULIC VERSION UNIT

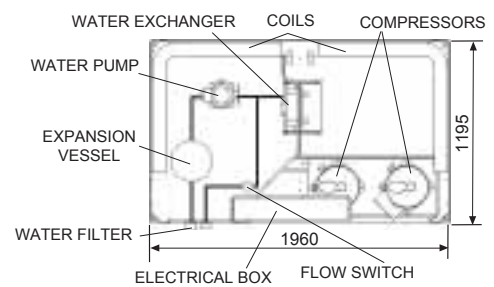

COMPONENT POSITION HYDRONIC VERSION UNIT

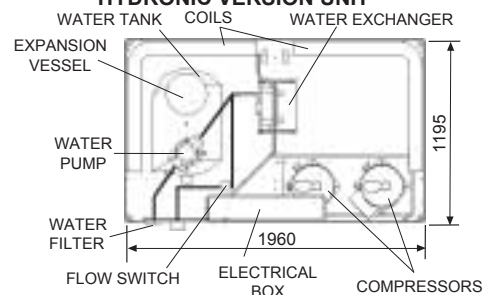

1.- GENERAL CHARACTERISTICS

1.9.- DIMENSIONS

EAC/EAR 1003SM-1103SM-1203SM-1303SM-1403SM

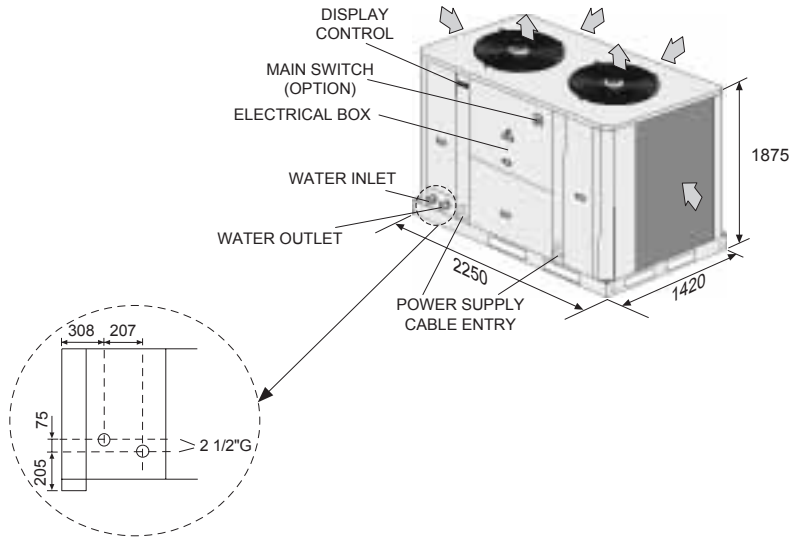

COMPONENT POSITION STANDARD VERSION UNIT

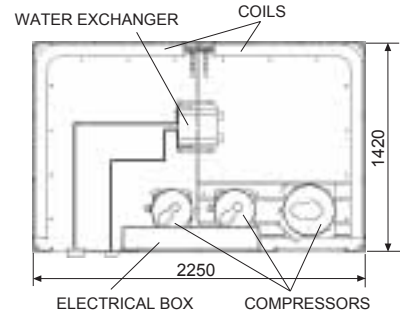

EAC/EAR 1003SM-1103SM-1203SM-1303SM-1403SM FP1/FP2

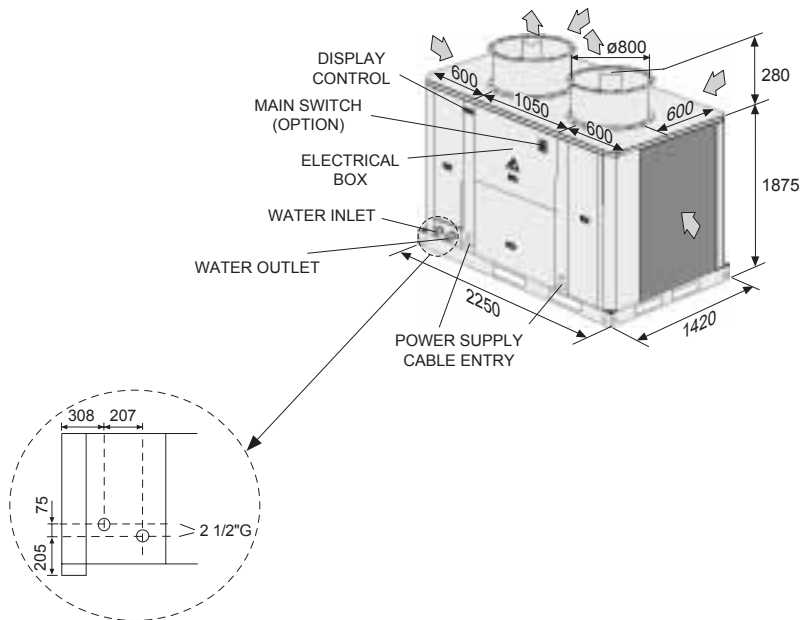

COMPONENT POSITION HYDRAULIC VERSION UNIT

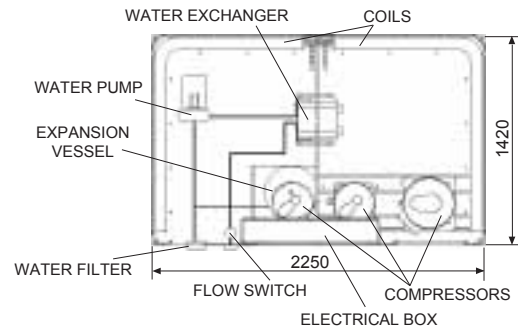

COMPONENT POSITION HYDRONIC VERSION UNIT

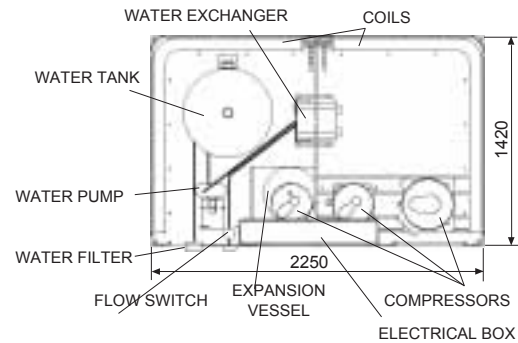

1.- GENERAL CHARACTERISTICS

1.9.- DIMENSIONS

EAC/EAR 1604SM

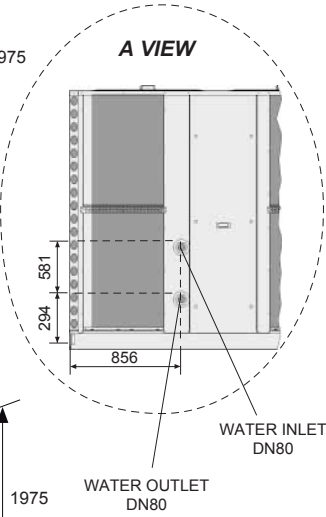
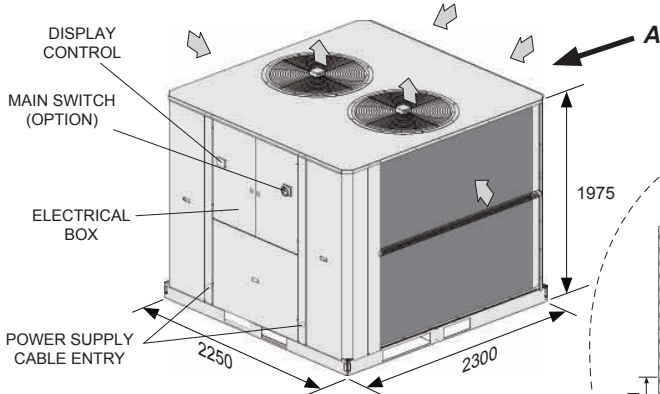

COMPONENT POSITION STANDARD VERSION UNIT

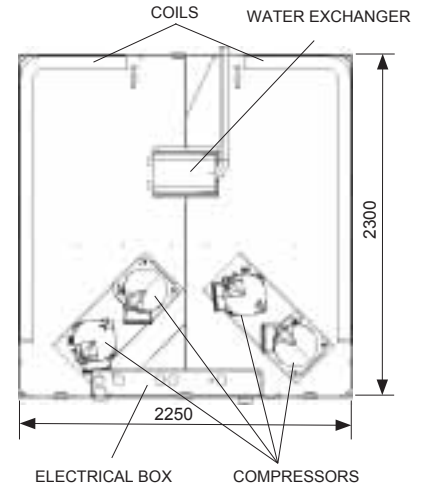

EAC/EAR 1804SM

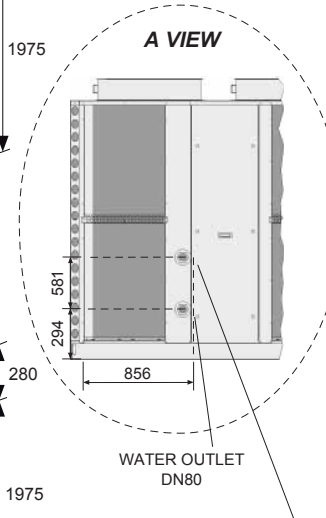
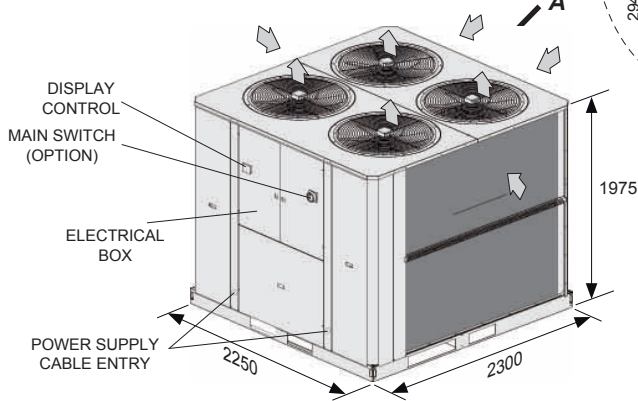

COMPONENT POSITION HYDRAULIC VERSION UNIT

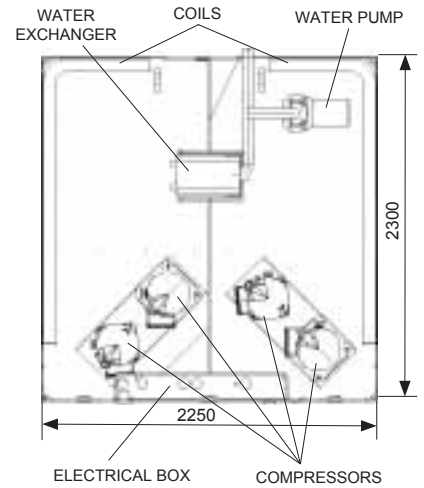

EAC/EAR 1604SM FP1/FP2

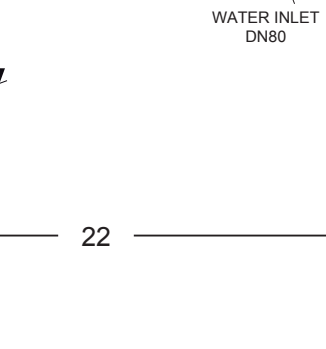
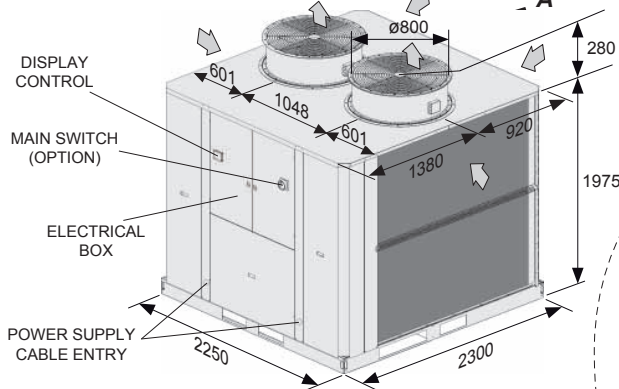

COMPONENT POSITION HYDRONIC VERSION UNIT

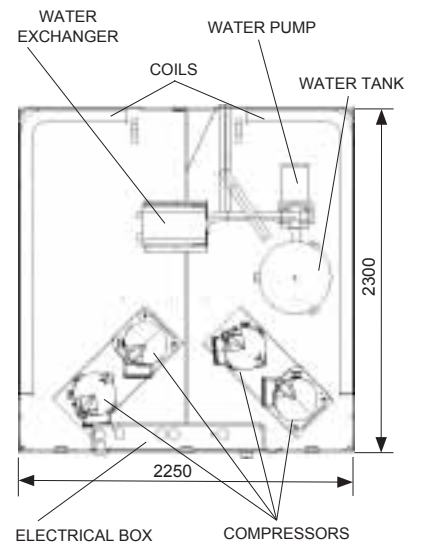

EAC/EAR 1804SM FP1/FP2

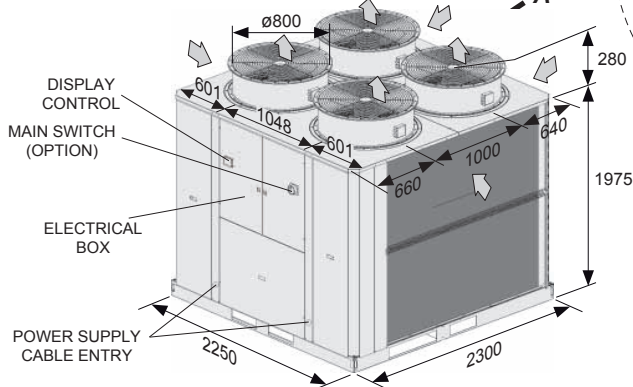

1.- GENERAL CHARACTERISTICS

1.10.- AVAILABLE OPTIONS

	<i>Standard version unit</i>	<i>Hydraulic version unit</i>	<i>Hydronic (1) version unit</i>
COIL TREATMENT			
Epoxy coated al fins coils treated	X	X	X
ELECTRICAL			
Main ON/OFF switch (400V/III)	X	X	X
Soft starter	X	X	X
Three phase protection	X	X	X
Evaporator antifreeze protection	X	X	X
Tank antifreeze heater (400V/III)	Not available	Not available	X
Water tank electrical heater (400V/III) (3)	Not available	Not available	X
REFRIGERANT CIRCUIT			
HP & LP refrigerant gauges	X	X	X
Kit low water temperature	X	X	X
Kit low ambient (-15°C) cooling, models EAC (4)	X	X	X
Kit low ambient (-15°C) heating, models EAR	X	X	X
Thermostatic hot gas injection	X	X	X
HYDRAULIC			
Flow switch	X	Included	Included
Water filter (supplied loose)	X	Included	Included
In/Out isolating valves (supplied loose)	X	X	X
Twin pump (5)	Not available	X	X
CONTROL			
ModBus	X	X	X
Dynamic set point	X	X	X
Remote display (supplied loose)	X	X	X
OTHER OPTIONS			
Coils protection guards	X	X	X
Compressor noise insulation jacket	X	X	X
Anti-vibration (supplied loose)	X	X	X
Inlet-plenum (supplied loose)	X	X	X
Square discharge duct ECOLEAN R410A (2)	X	X	X
Drip tray (6)	X	X	X

X Option element.

(3) Only for heat pumps units.

With twin pumps, water filter has to be mounted outside the unit. (1003 to 1403 models).

(1) Water tank included.

(4) Not available for units EAC 0251 FP2 to 0812 FP2.

(2) Only versions FP1/FP2.

(5) For models 0251 to 1804.

(6) Only for heat pumps units with FP1/FP2.



NOTE: All the options will be supplied and mounted in the unit, except the water filter, water isolation valves, rubber antivibration mounts, remote controller and air intake plenum supplied to mount in the moment of installation.

1.10.1.- COIL TREATMENT

EPOXY COATED ALUMINIUM FIN COILS TREATED

Special protection of the aluminium condenser coil fins, to give improved protection from aggressive external environmental conditions.

1.10.2.- ELECTRICAL OPTIONS

MAIN ON/OFF SWITCH

Located at the electrical box of the unit.

SOFT STARTER

It is an electronic element, which reduces the peak compressor starting current up to 40%.

THREE PHASE PROTECTION

Located at electrical box of the unit. It assures that unit will not begin operation on detection of overvoltage, undervoltage, phase reversal fault or phase failure.

EVAPORATOR ANTI FREEZE PROTECTION

The evaporator anti freeze heater prevents the water exchange from low temperatures.

1.- GENERAL CHARACTERISTICS

1.10.- AVAILABLE OPTIONS

TANK ANTI-FREEZE HEATER AND WATER TANK ELECTRICAL HEATER (available only for Hydronic version)

An immersion heater can be supplied complete with safety thermostat and pressure switch fitted in the buffer tank, or an anti-freeze and supplementary heater (heat pump units only).

Tank Anti-freeze heater: It starts when water temperature in the buffer tank is lower than + 5°C (Not for units with low water temperature kit).

Water tank electrical heater: Heat pump units only. The heater works as anti-freeze heater as explained before and as supplementary heater, when inlet warm water reaches a temperature below a value selected (example: 30 °C) through an independent thermostat included.

THE POWER INPUT IS:

(*) Heat pump units only

MODELS	0251SM to 0431SM	0472SM to 0812SM	1003SM to 1403SM	1604SM / 1804SM	
Voltage	V	3~400V			
Tank anti-freeze heater	KW	2,25	2,25	6,0	9
Water tank electrical heater*	KW	9	12	24,0	36,0

1.10.3.- REFRIGERANT CIRCUIT OPTION

HP & LP REFRIGERANT GAUGES

Visualize the high and low pressures of the refrigerant circuit.

LOW WATER TEMPERATURE

Necessary for water outlet temperatures below +5°C.

There are three different kits, which depend for selecting on the water outlet temperature desired, as the following table shows:

Denomination	Application duty on the water outlet temperature
KIT LOW WATER TEMPERATURE 0°C	For water temperatures below 5°C to 0°C
KIT LOW WATER TEMPERATURE -5°C	For water temperatures below 0°C to -5°C
KIT LOW WATER TEMPERATURE -10°C	For water temperatures below -5°C to -10°C

LOW AMBIENT KIT (-15°C). COOLING

The cooling only unit can operate down to an ambient temperature of -15°C (standard unit just can operate down to 0°C).

LOW AMBIENT KIT (-15°C) HEATING

The reverse unit can operate in heating mode down to an ambient temperature of -15°C (standard unit just can operate down to -10°C).

THERMOSTATIC HOT GAS INJECTION

Supplies hot gas which is injected into the evaporator gas to increase the suction pressure if the chilled water temperature falls to low. It can be used to allow the unit to operate at reduced capacity, if the water temperature falls below the set point (5°C). It is controlled via the microprocessor controller ON at (5°C) and OFF (6°C) for example. This option is NOT available for units selected with low water temperature option.

1.10.4.- HYDRAULIC OPTIONS

FLOW SWITCH (included on Hydraulic and Hydronic versions).

The flow switch stops the unit if water flow is lower than the minimum.

WATER FILTER (included on Hydraulic and Hydronic versions).

The water filter must be fitted in the water inlet of the unit, it protects the unit against particles (greater than 1 mm) getting inside the water circuit, and prevents the water interchanger gets dirty.

IN/OUT ISOLATING VALVES

To fit at inlet and water outlet of the unit. Isolating the unit from water circuit, so service and maintenance of the unit will be easier.

For units EAC 1003 to 1804 SMHN this option includes another valve in order to isolate the buffer tank.

TWIN PUMPS KIT (only available on Hydraulic and Hydronic versions)

It is formed by two-water pump mounted on parallel and with same characteristics as the single one. Only one pump is working the other remains on stand by.

When the water pump, which is operating cuts out, and the pump turns off, automatically starting the water pump on stand by.

It is possible to select which one of the pumps we want to be working through an external switch supplied with the kit.

With the twin pumps, the available static pressure will decrease 5% from the available static pressure with one water pump only.

1.10.5.- CONTROL OPTIONS

MODBUS

It is possible to connect several units with a communication system (MOD BUS Protocol).

DYNAMIC SET POINT

It changes cooling and heating set point according ambient temperature (an extra sensor must be installed).

REMOTE DISPLAY

It controls and shows the unit's operating, it may be installed until 50 m from the unit.

1.- GENERAL CHARACTERISTICS

1.10.- AVAILABLE OPTIONS

1.10.6.- OTHER OPTIONS

COIL PROTECTION GUARDS

The condenser coil protection grill prevents light damage to the coil when shipping and when installed. It cannot protect against very heavy impacts.

COMPRESSOR NOISE INSULATION JACKET

Each compressor is fitted with a compressor acoustic jacket this provides attenuation of the compressor noise that radiates from the unit when in operation.

ANTI-VIBRATION

To install under the unit, to avoid transmission of vibrations, to the floor where unit is installed, while unit is operating. Two different type: rubber or prings anti-vibrations (according to models).

INLET PLENUM (models from 0251 to 1403 only)

It is a accessory for adapting the condenser air intake to accept a duct.

SQUARE DISCHARGE DUCT

It is formed by 1 or 2 square frames, for adapting discharge air from the unit to a square duct.

0251 to 0431 MODELS

Square discharge duct
848x848

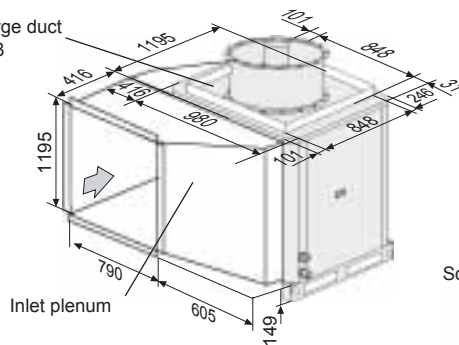

0472 to 0812 MODELS

Square discharge duct
848x848

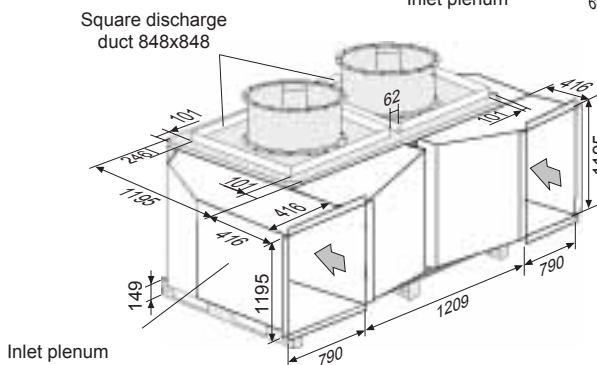

1003 to 1403 MODELS

Square discharge duct
992x992

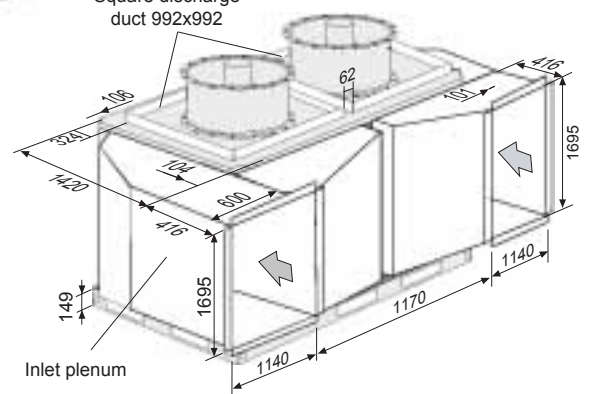

1604 MODEL

Square discharge duct
992x992

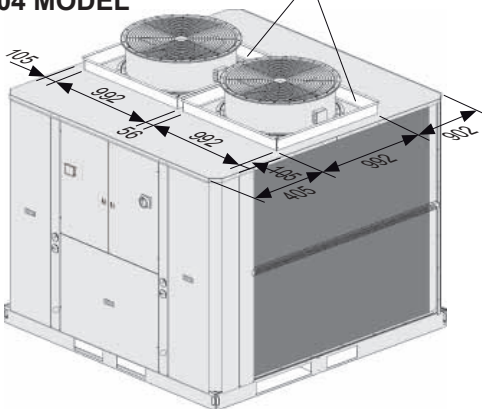

1804 MODEL

Square discharge duct
992x1992,5

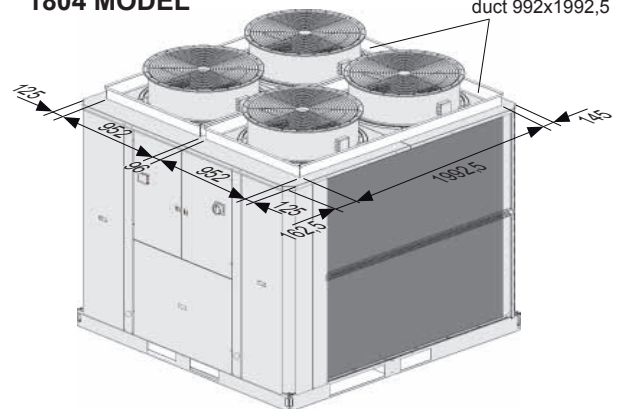

AUXILIAR DRIP TRAY (Only available for heat pump units with FP1/FP2 option)

Heat pump units during defrost cycle produce a lot of quantity of water. You can use an auxiliary drip tray under the unit in order to get all the defrost water and take it where you decided.

2.- INSTALLATION

2.1.- SITE AND SHIPPING GUIDANCE



Todas las operaciones de **INSTALACIÓN, SERVICIO Y MANTENIMIENTO** deben ser realizadas por **PERSONAL CUALIFICADO**.

The unit must be transported in a **HORIZONTAL POSITION** on its metal bedplate profiles . Any other position may cause serious damage to the machine.

When the unit is received, it should be checked to assure that there are no bumps or other damage, following the instructions on the packaging. If there is damage, the unit may be rejected by notifying the **LENNOX Distribution Department** and reporting why the machine is unacceptable on the transport agent's delivery notice. Any later complaint or claim made to the **LENNOX Distribution Department**, for this type of anomaly, cannot be considered under the **Guarantee**.

Sufficient space must be allowed to facilitate placement of the unit. The unit may be mounted outdoors. There should be adequate drainage around the unit.

In heat pump units during defrost cycle, the units produce a great amount of water melting the ice off coils. If you wish to drain the water, adequate drainage should be installed behind the unit to collect and carry out the water where desired.



When positioning the unit, be sure that the **Rating Plate** will always be visible since this data will be necessary to assure proper maintenance.

It is advisable to unpack the unit at the place where the unit is going to be installed, to avoid damages during manage.

2.2.- UNIT LIFTING

How to hoist the unit

If unloading and placement requires the use of a crane, then secure the suspension cables as shown in the figure. The unit can only be lifted and moved by its base.

WITH HOOK

WITH BALANCE BEAM

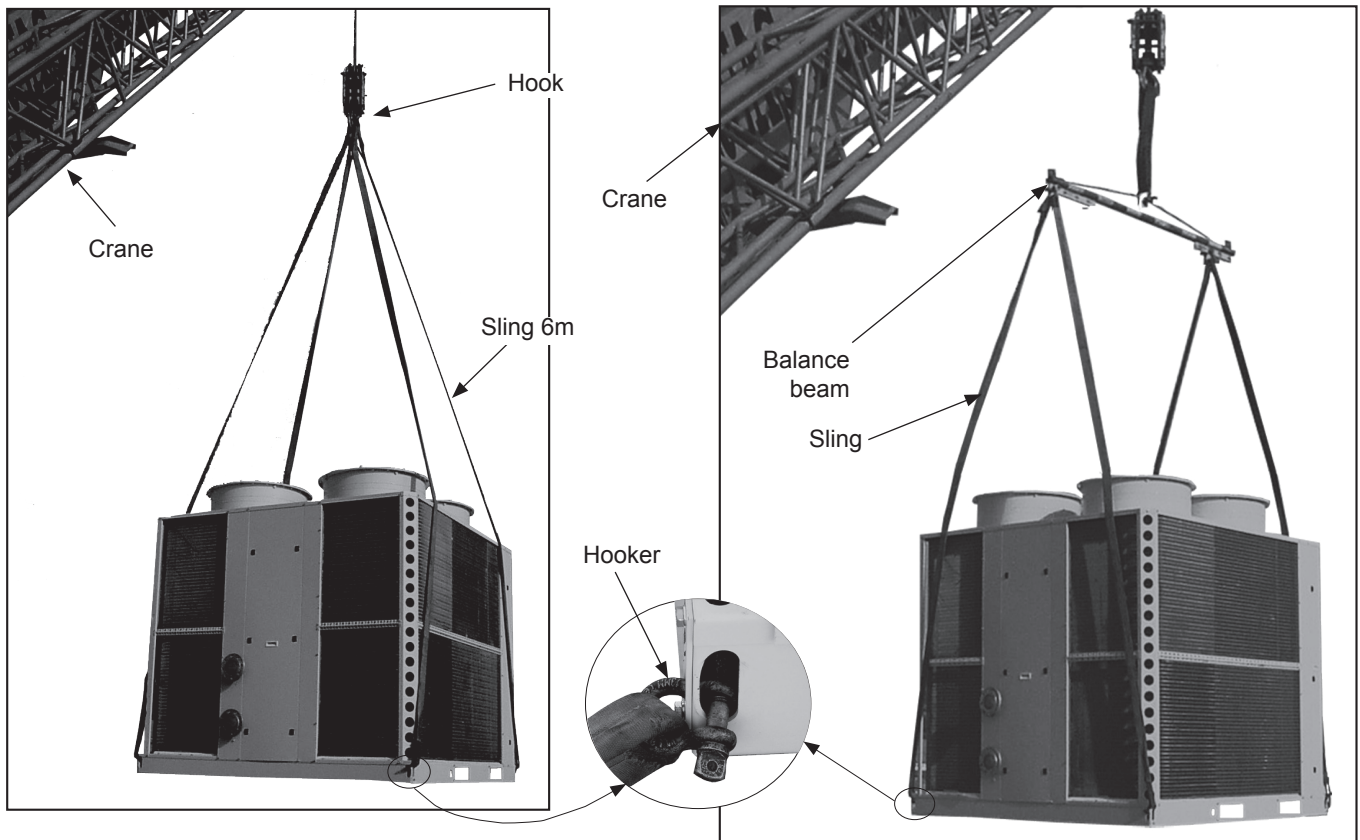

NOTE: Use slingers of 6 m with the hook in order to prevent pressure on the top of the unit because it can be damaged. Whenever it is possible, use balance beam.

2.- INSTALLATION

2.3.- ANTIVIBRATION MOUNTING

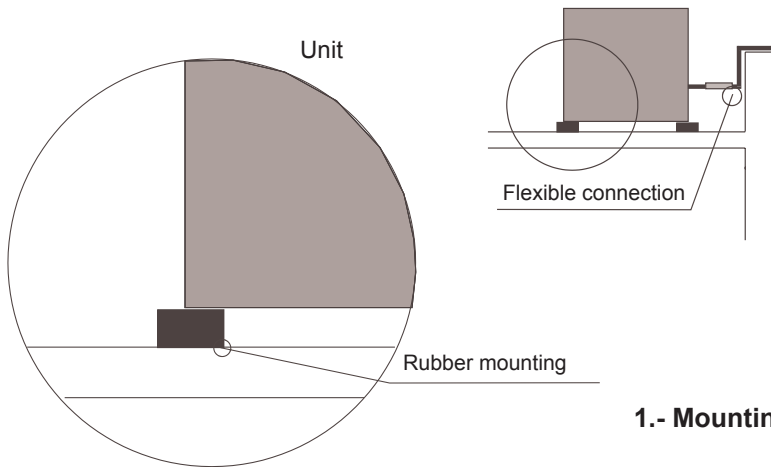

1.- Mounting on a low sensibility zone

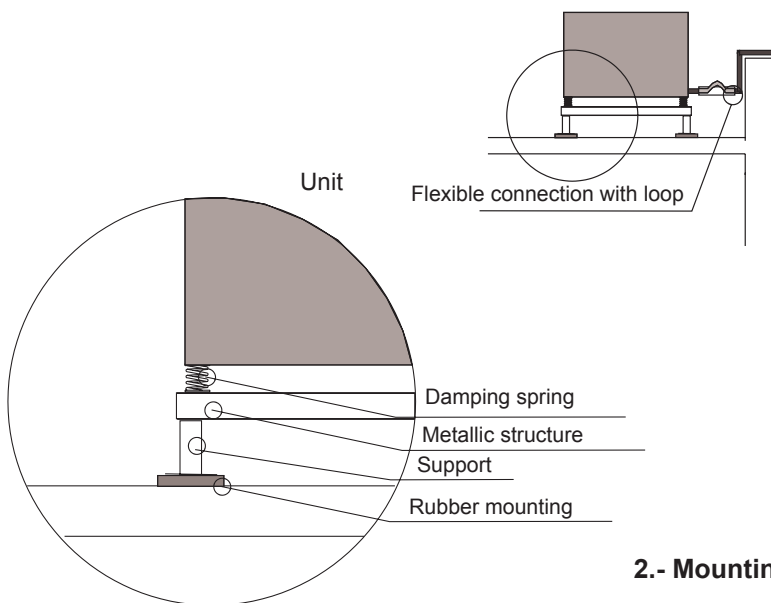

2.- Mounting on a medium sensibility zone

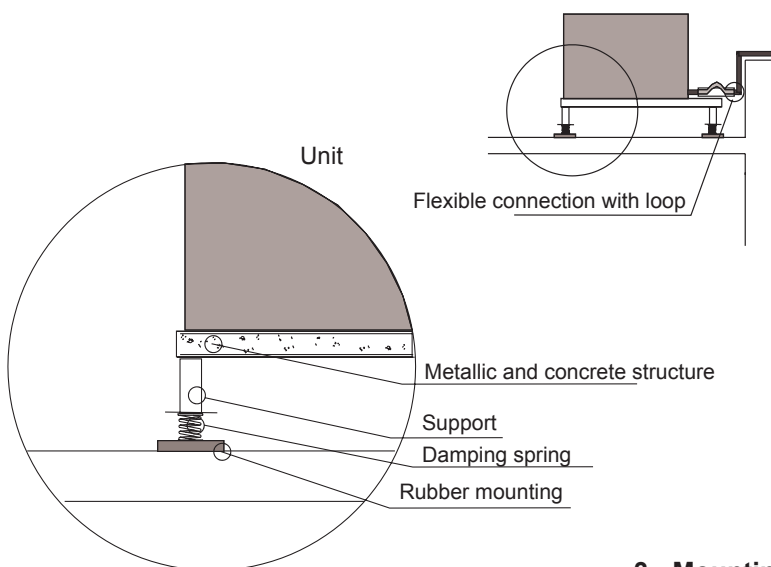

**3.- Mounting on a high sensibility zone
(Check floor load)**

2.- INSTALLATION

2.4.- INSTALLATION CLEARANCES

(*) Clearance around the unit, for all unit versions.
Failure to install the units as shown will impact performance and reliability.

INSTALLATION CLEARANCES

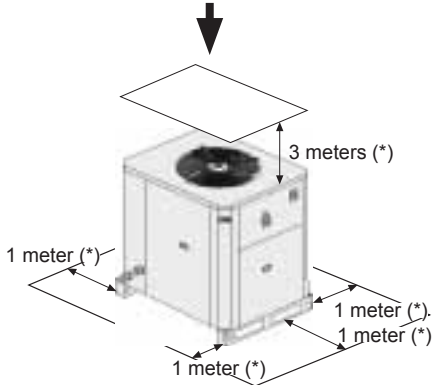

EAC/EAR
0251SM-0291SM-0351SM-0431SM

DETAILING AVM POSITIONS

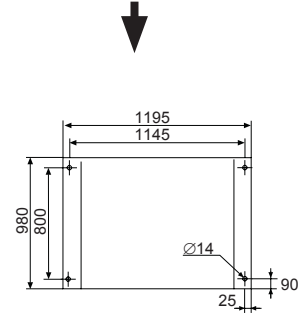

EAC/EAR
0472SM-0552SM-0672SM-0812SM

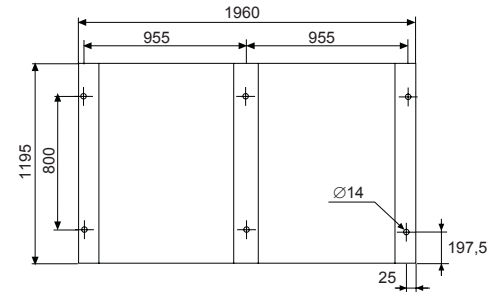
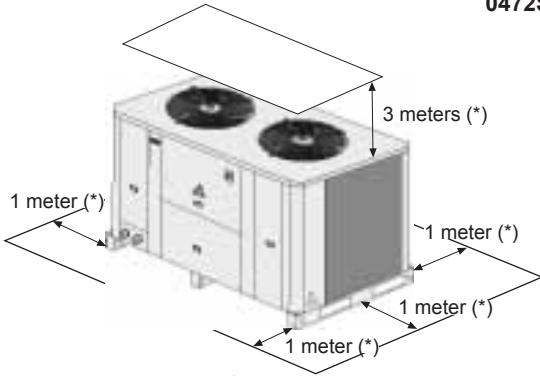

EAC/EAR
1003SM-1103SM-1203SM-1303SM-1403SM

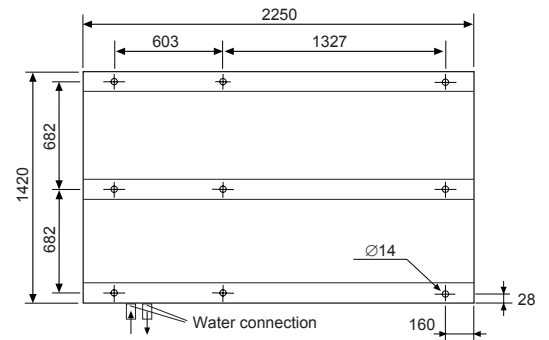
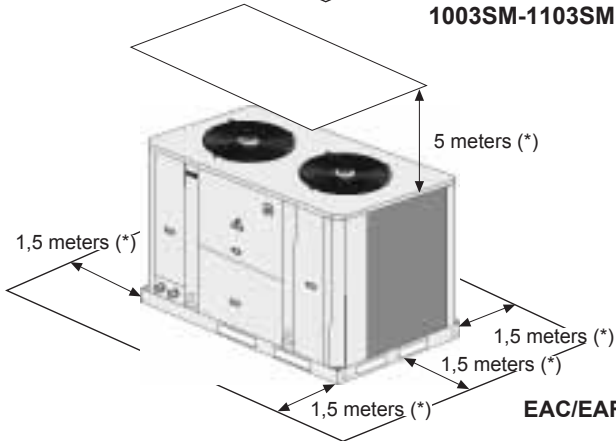

EAC/EAR 1604SM-1804SM

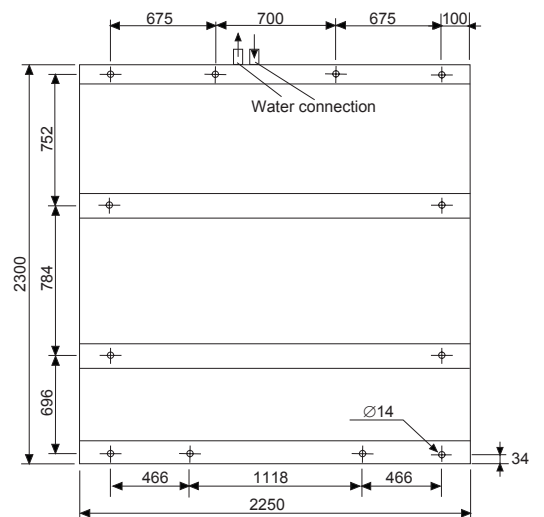
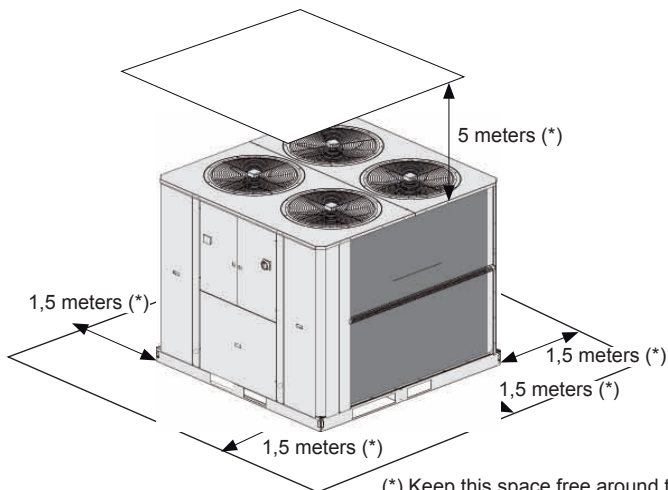

(*) Keep this space free around the unit for installation, for all unit versions.

2.- INSTALLATION

2.5.- DETAILING SPRING ANTI-VIBRATION POSITION (EAC/R 1003-1804 SM)

EAC/R 1003 TO 1403 SM.

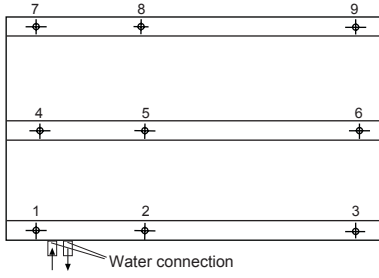

POSITION Nr.	ANTI-VIBRATION TYPE
1	350
2	350
3	350
4	350
5	350
6	350
7	250
8	250
9	250

EAC/R 1604 TO 1804 SM.

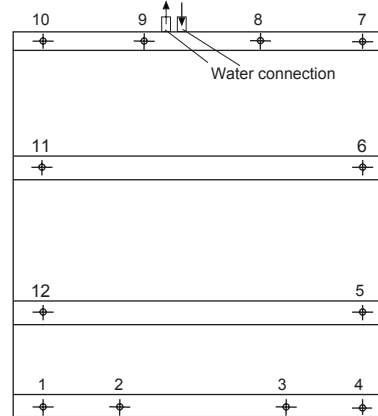

POSITION Nr.	ANTI-VIBRATION TYPE
1	350
2	500
3	500
4	500
5	500
6	500
7	500
8	350
9	350
10	350
11	350
12	350

2.6.- WEIGHT APPROXIMATE DISTRIBUTION (Kg) (EAC/R 1003-1804 SM)

EAC/R 1003 SM.

Nr. POSITION	(*) HYDRONIC UNIT (WEIGHT Kg)				HYDRAULIC UNIT (WEIGHT Kg)				STANDARD UNIT (WEIGHT Kg)			
	EAC STD	EAR STD	EAC FP1/FP2	EAR FP1/FP2	EAC STD	EAR STD	EAC FP1/FP2	EAR FP1/FP2	EAC STD	EAR STD	EAC FP1/FP2	EAR FP1/FP2
1	117	120	122	125	90	93	95	98	88	91	93	96
2	117	120	122	125	90	93	95	98	88	91	93	96
3	117	120	122	125	90	93	95	98	88	91	93	96
4	114	117	119	121	77	80	82	85	73	76	78	80
5	114	117	119	121	77	80	82	85	73	76	78	80
6	114	116	118	121	77	80	82	85	73	76	78	80
7	90	92	93	96	55	57	58	61	52	54	56	58
8	90	92	93	96	55	57	58	61	52	54	56	58
9	90	92	93	95	55	57	58	60	52	54	56	58
TOTAL(Kg)	961	984	1001	1024	666	689	706	729	640	663	680	703

EAC/R 1403 SM.

Nr. POSITION	(*) HYDRONIC UNIT (WEIGHT Kg)				HYDRAULIC UNIT (WEIGHT Kg)				STANDARD UNIT (WEIGHT Kg)			
	EAC STD	EAR STD	EAC FP1/FP2	EAR FP1/FP2	EAC STD	EAR STD	EAC FP1/FP2	EAR FP1/FP2	EAC STD	EAR STD	EAC FP1/FP2	EAR FP1/FP2
1	163	167	168	172	136	140	141	145	135	138	140	143
2	163	167	168	171	136	140	141	144	135	138	140	143
3	163	167	168	171	136	140	141	144	135	138	140	143
4	159	162	164	167	123	126	127	131	117	120	122	125
5	159	162	164	167	123	126	127	131	117	120	122	125
6	159	162	164	167	123	126	127	130	117	120	122	125
7	125	128	129	131	90	93	94	96	88	90	91	94
8	125	128	129	131	90	93	94	96	88	90	91	94
9	125	128	129	131	90	93	94	96	88	90	91	94
TOTAL(Kg)	1343	1369	1383	1409	1048	1074	1088	1114	1019	1045	1059	1085

EAC/R 1103 SM.

Nr. POSITION	(*) HYDRONIC UNIT (WEIGHT Kg)				HYDRAULIC UNIT (WEIGHT Kg)				STANDARD UNIT (WEIGHT Kg)			
	EAC STD	EAR STD	EAC FP1/FP2	EAR FP1/FP2	EAC STD	EAR STD	EAC FP1/FP2	EAR FP1/FP2	EAC STD	EAR STD	EAC FP1/FP2	EAR FP1/FP2
1	138	140	142	145	111	113	115	118	109	112	114	117
2	137	140	142	145	110	113	115	118	109	112	114	116
3	137	140	142	145	110	113	115	118	109	112	114	116
4	134	136	139	141	97	100	102	105	93	96	98	100
5	134	136	139	141	97	100	102	105	93	96	98	100
6	134	136	138	141	97	100	102	105	93	96	98	100
7	105	107	109	111	70	72	74	76	68	70	72	74
8	105	107	109	111	70	72	74	76	68	70	72	74
9	105	107	109	111	70	72	74	76	68	70	71	73
TOTAL(Kg)	1130	1152	1170	1192	835	857	875	897	809	831	849	871

EAC/R 1604 SM.

Nr. POSITION	(*) HYDRONIC UNIT (WEIGHT Kg)				HYDRAULIC UNIT (WEIGHT Kg)				STANDARD UNIT (WEIGHT Kg)			
	EAC STD	EAR STD	EAC FP1/FP2	EAR FP1/FP2	EAC STD	EAR STD	EAC FP1/FP2	EAR FP1/FP2	EAC STD	EAR STD	EAC FP1/FP2	EAR FP1/FP2
1	96	97	98	99	76	77	78	79	75	76	77	78
2	213	215	218	220	193	195	198	200	192	195	197	199
3	178	180	182	184	148	150	152	154	147	149	151	153
4	163	165	167	169	120	122	124	125	118	120	122	123
5	179	181	183	185	109	111	113	115	107	109	111	113
6	196	198	201	203	126	128	131	133	122	124	127	129
7	213	215	218	220	170	172	175	177	166	168	171	173
8	99	100	101	102	55	57	58	59	51	53	54	55
9	108	109	111	112	88	89	91	92	84	85	87	88
10	117	118	120	121	97	98	100	101	95	97	98	99
11	110	111	112	114	90	91	92	94	88	89	91	92
12	103	104	105	106	83	84	85	86	82	83	84	85
TOTAL(Kg)	1775	1794	1815	1834	1355	1374	1395	1414	1328	1347	1368	1387

EAC/R 1203 SM.

Nr. POSITION	(*) HYDRONIC UNIT (WEIGHT Kg)				HYDRAULIC UNIT (WEIGHT Kg)				STANDARD UNIT (WEIGHT Kg)			
	EAC STD	EAR STD	EAC FP1/FP2	EAR FP1/FP2	EAC STD	EAR STD	EAC FP1/FP2	EAR FP1/FP2	EAC STD	EAR STD	EAC FP1/FP2	EAR FP1/FP2
1	153	156	158	161	126	129	131	134	125	128	130	133
2	153	156	158	161	126	129	131	134	125	128	129	133
3	153	156	158	161	126	129	131	134	125	128	129	133
4	149	152	154	157	113	116	118	121	108	111	113	116
5	149	152	154	157	113	116	118	121	108	111	113	116
6	149	152	154	157	113	116	117	120	108	111	113	116
7	117	120	121	124	82	85	86	89	80	82	84	86
8	117	120	121	124	82	85	86	89	80	82	84	86
9	117	120	121	123	82	85	86	88	80	82	83	86
TOTAL(Kg)	1259	1285	1299	1325	964	990	1004	1030	938	964	978	1004

EAC/R 1804 SM.

Nr. POSITION	(*) HYDRONIC UNIT (WEIGHT Kg)				HYDRAULIC UNIT (WEIGHT Kg)				STANDARD UNIT (WEIGHT Kg)			
	EAC STD	EAR STD	EAC FP1/FP2	EAR FP1/FP2	EAC STD	EAR STD	EAC FP1/FP2	EAR FP1/FP2	EAC STD	EAR STD	EAC FP1/FP2	EAR FP1/FP2
1	116	117	121	122	96	97	101	102	95	96	100	101
2	258	260	267	270	238	240	247	250	237	239	246	249
3	215	217	223	225	185	187	193	195	184	186	192	194
4	198	199	205	207	154	156	162	163	150	152	158	159
5	216	218	224	226	146	148	154	156	142	144	150	152
6	238	240	246	249	168	170	176	179	160	162	168	171
7	258	260	267	270	214	217	224	226	206	209	216	218
8	120	121	124	125	76	77	81	82	68	69	73	74
9	131	132	136	137	111	112	116	117	108	109	113	114
10	142	143	147	148	122	123	127	128	119	120	124	125
11	133	134	138	139	113	114	118	119	110	111	115	116
12	124	125	129	130	104	105	109	110	103	104	108	109
TOTAL(Kg)	2148	1765	1814	1830	1728	1748	1808	1828	1683	1703	1763	1783

EAC/R 1303 SM.

Nr. POSITION	(*) HYDRONIC UNIT (WEIGHT Kg)				HYDRAULIC UNIT (WEIGHT Kg)				STANDARD UNIT (WEIGHT Kg)			
	EAC STD	EAR STD	EAC FP1/FP2	EAR FP1/FP2	EAC STD	EAR STD	EAC FP1/FP2	EAR FP1/FP2	EAC STD	EAR STD	EAC FP1/FP2	EAR FP1/FP2
1	160	163	164	168	133	136	137	141	131	134	136	139
2	160	163	164	168	133	136	137	141	131	134	136	139
3	160	163	164	168	133	136	137	141	131	134	136	139
4	155	158	160	163	119	122	124	127	114	118	119	122
5	155	158	160	163	119	122	124	127	114	118	119	122
6	155	158	160	163	119	122	124	127	114	117	119	122
7	122	125	126	128	87	90	91	93	85	87	88	91
8	122	125	126	128	87	90	91	93	85	87	88	91
9	122	125	126	128	87	90	91	93	85	87	88	91
TOTAL(Kg)	1311	1337	1351	1377	1016	1042	1056	1082	990	1016	1030	1056

(*) Hydronic unit weight has been calculated with water inside the buffer tank.

2.- INSTALLATION

2.7.- UNIT INSTALLATION

- 1.- The EcoLean™ units could be installed outside or inside.
- 2.- See the minimum clearance diagrams for access - air supply to the batteries in the heating section of the unit (see page 28).
- 3.- Assemble the unit on a resistant base, preferably concrete. To prevent vibrations, the concrete base should not come into contact with the building's foundations.
- 4.- It is advisable to assemble the unit on shock absorbers (antivibration mountings).
- 5.- During heating mode (heating pump coolers) ice forms in the coils. The defrost process is activated during heating mode in heat pump units, when the outside temperature is low and the outdoor coil could become frozen.
To melt the ice, the defrost function will switch the unit to cooling operation for a short period. When the evaporation temperature starts to drop, a defrost period sets in to provide sufficient heat transfer. During defrosting, the ice melts from the batteries. As a result, the ice contains water which must be removed.

WARNING



If the unit is exposed for long periods to installation conditions below 0°C the water from defrost can freeze in the base of the unit. This prevents drainage. Ice build up can occur preventing correct operation. For these conditions contact customer service team.

- 6.- The heat exchanger water flow during cooling must be the same as during heating.
- 7.- Fit a water filter in the unit inlet.



It is obligatory to install a mesh filter in units not equipped with Hydronic or Hydraulic module. The step of the mesh should not be superior to 1 mm.

- 8.- Use water treating if necessary.
- 9.- The water inlet to the circuit has to be filled from lowest point, with purges opened, to prevent air being trapped.
- 10.- Location inside:

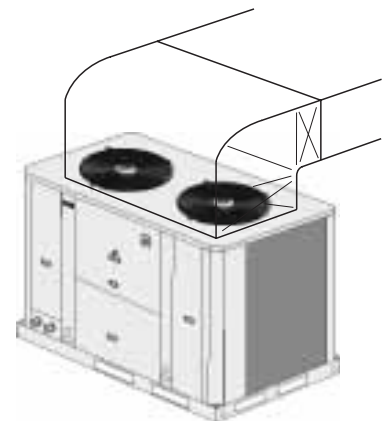
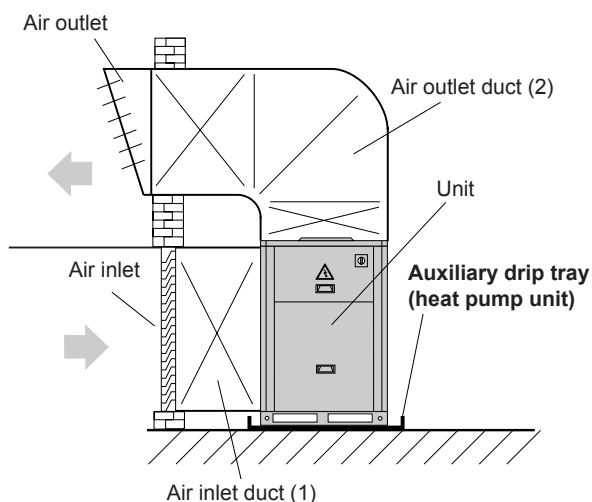

In heat pump units with double circuits and cooling only units 1003SM to 1804SM, if only one duct is going to be installed, a regulated pressure damper should be installed for each fan, to avoid air by-pass through the fan if it has stopped.

For location inside, keep in mind following advice:

- In heat pump units during defrost cycle, the units produce a great amount of water melting the ice off coils. If you wish to drain the water, adequate drainage should be installed below the unit to collect and carry out the water where desired.

- Air duct installation:

If air duct has been installed, the operating limits get reduced (see operation limits section in this manual).

- (1) The air intake plenum (option) available for models from 0251 to 1403 makes easier the installation of the air intake duct (see page 24).
- (2) The discharge plenum (option) lets the installation of a square discharge duct for the high static pressure units FP1 and FP2 (see page 24).

2.- INSTALLATION

2.7.- UNIT INSTALLATION

- 11.- For cooling or heat pump units the hydraulic system must contain the following components pump, buffer tank, expansion device, safety valve, water filter, flow switch.
- 12.- To obtain the total water system pressure drop add the unit pressure drop + water pipework + fittings and terminal unit pressure drops the water pump can be selected to provide the correct water flow across the heat exchanger.
- 13.- A water balancing valve is advised to ensure correct water flow.



IMPORTANT

If the outside temperature in the area where the EcoLean™ unit is to be installed is likely to drop below 5°C, it is very important to take the following precautions to avoid that water in the circuit freezing, that may produce damage to the components.

- If unit has to work under low outside temperatures:

* Do not disconnect power supply in order that water pump starts when detects water temperatures below +5 °C (only Hydraulic and Hydronic models).

* If the outside temperature where the system is to be installed or the water outlet temperature is likely to drop below 5°C, it is very important to use glycol anti-freeze.

The amount of anti-freeze required will vary depending on the minimum ambient temperature or the water outlet temperature.

When the percentage of glycol increases the standard pump flow decreases, the pressure drop increases and the cooling and thermal capacities drop. As a result the minimum flow must be multiplied by the coefficient shown in the table:

MINIMUM AMBIENT TEMPERATURE OR WATER OUTLET TEMPERATURE	ETHYLENE GLYCOL %	PRESSURE DROP	WATER FLOW	POWER INPUT	CAPACITIES	
					COOL	HEAT
FROM +5°C TO 0°C	10%	1,05	1,02	0,997	0,995	0,994
FROM 0°C TO -5°C	20%	1,10	1,05	0,996	0,985	0,993
FROM -5°C TO -10°C	30%	1,15	1,08	0,995	0,975	0,99
FROM -10°C TO -15°C	35%	1,18	1,10	0,994	0,965	0,987

Example: 10 % glycol in EAC 0251SMHN
 Minimum flow: 3,16 m³/h x 1,02
 Pressure drop: 175 x 1,05
 System capacity x 0,995
 Power input x 0,997

Also is advisable to use the option “evaporator anti freeze protection”

Failure to follow this advice, may result in damage to the installation.

Optionally, an immersion heater can be supplied complete with safety thermostat and pressure switch fitted in the buffer tank of the cooling only chiller. A similar option is available for heat pump versions with the added advantage of a supplementary heating source (Hydronic version units).

2.- INSTALLATION

2.8.-ELECTRICAL CONNECTIONS

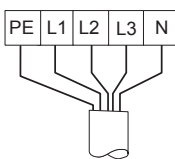

- BEFORE MAKING ANY ELECTRICAL CONNECTIONS, BE SURE THAT ALL CIRCUIT BREAKERS ARE OPEN AND SUPPLY IS OFF.
- IN ORDER TO CARRY OUT THE ELECTRICAL CONNECTIONS, FOLLOW THE ELECTRICAL DIAGRAM SUPPLIED WITH THE UNIT.

POWER SUPPLY	UNIT MODEL	NUMBER OF WIRES X SECTION	
		WITHOUT AEH	WITH AEH
THREE-PHASE UNITS 400V  3N ~ 400V-50Hz + PE	0251SM	5 x 6 mm ²	5 x 10 mm ²
	0291SM	5 x 6 mm ²	5 x 10 mm ²
	0351SM	5 x 10 mm ²	5 x 10 mm ²
	0431SM	5 x 10 mm ²	5 x 16 mm ²
	0472SM	5 x 16 mm ²	3 x 25+2x16 mm ²
	0552SM	5 x 16 mm ²	3 x 25+2x16 mm ²
	0672SM	3 x 25+2x16 mm ²	3 x 25+2x16 mm ²
	0812SM	3 x 25+2x16 mm ²	3 x 35+2x16 mm ²
	1003SM	3 x 25+2x16 mm ²	3 x 50+2x25 mm ²
	1103SM	3 x 35+2x16 mm ²	3 x 50+2x25 mm ²
	1203SM	3 x 35+2x16 mm ²	3 x 50+2x35 mm ²
	1303SM	3 x 50+2x25 mm ²	3 x 50+2x35 mm ²
	1403SM	3 x 50+2x35 mm ²	3 x 50+2x35 mm ²
	1604SM	3 x 50+2x35 mm ²	3 x 95+2x50 mm ²
1804SM	3 x 50+2x35 mm ²	3 x 95+2x50 mm ²	

- AEH: Auxiliary Electric Heater
- The cable sections have been calculated based on a distance of 50m and variation of -10V.
Do not start the unit if the drop is greater than this.
- The wiring and circuit breakers to be mounted in the installation must comply with the Regulations in force.
- Ground wires must be properly connected and have a greater length than the phase wires.

EAC/EAR 0251SM TO 1804SM

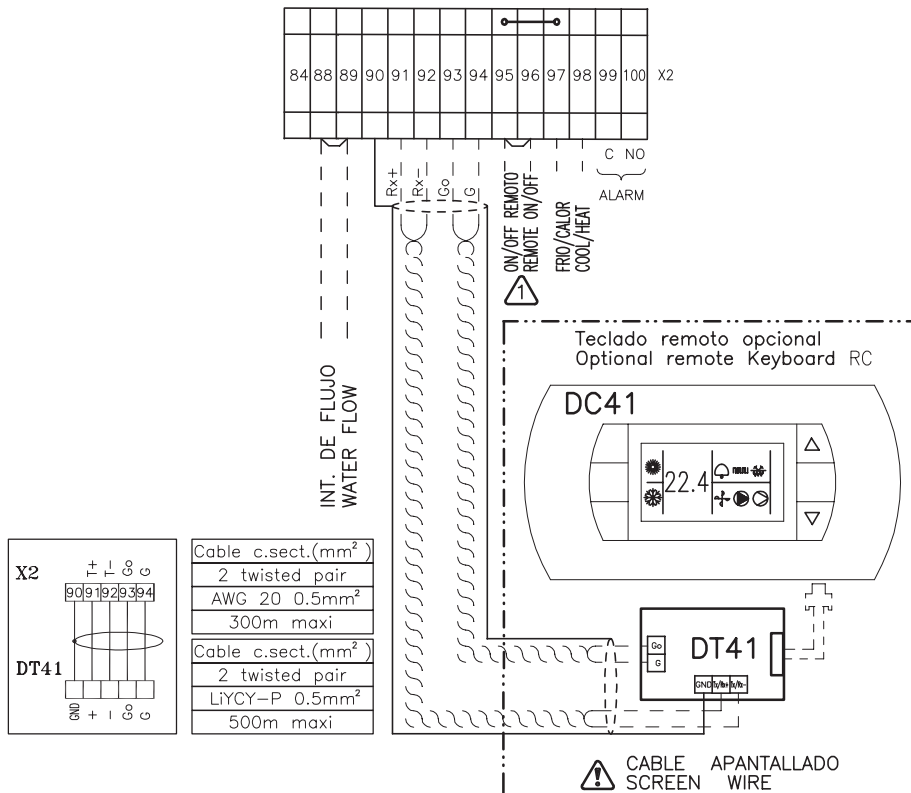

VOLTAGE OPERATION LIMITS

MODELS	VOLTAGE	LIMITS
0251SM A 1804SM	3N~400V-50Hz	3N~342-462V-50Hz

3.- COMMISSIONING AND OPERATION

3.1.- STEPS TO FOLLOW FOR COMMISSIONING THE UNITS

Before commissioning the unit check the following:

- 1.- Check that the voltage is the same as the rated voltage on the specification plate.
- 2.- Check that the supply to the control system is connected in accordance with the electrical diagram (if incorporates)
- 3.- Check that the main switch is ON (if incorporates).
- 4.- Make sure that the water connections are correct and have not been altered, as this can result in incorrect operation the flow divider will not operate if the connections are mixed
- 5.- Check that the fan can rotate freely.
- 6.- Check the water pump's direction of rotation.
- 7.- Check for air in the water system. Purge if necessary.
- 8.- The compressor must not be started until the crankcase heater has been running for at least 8 hours.

- The compressor has a single phase electric heating element to assure a separation between the Refrigerant and the oil in the housing. This heater is activated when the compressor is off and stops working when the compressor is on. About eight hours before start up or after a long shutdown period, voltage should be supplied to the unit so that this heater will be activated.
- Check that the compressor starts after two minutes.
- Select cool or heat as the operating mode at the control unit.
- When the compressor starts the fans rotate at maximum speed for a short time. They then rotate in accordance with the condensation temperature/pressure.



REMEMBER THAT THE COMPRESSOR IS A SCROLL TYPE COMPRESSOR:

Before starting the unit, the compressor should be checked that rotates in the correct direction, through a three phase protection. Scroll type compressors only compress in one direction of the rotation. Single phase models are always started up in the proper direction; however, the three phase models, turn in either direction depending on the order of the power supply phases. Therefore, it is essential that the phase connection for scroll-type three-phase compressors be carried out correctly (the correct direction of rotation can be checked when the pressure on the suction side decreases and the pressure on the discharge side increases when the compressor is activated). If the connection is wrong, the rotation will be reversed causing a high noise level and a reduction in the amount of current consumed. If this occurs, the compressor's internal protection system will operate in shutting down the unit. The solution is to disconnect, switch the wires between two of the phases and connect the three again).

ASTP Protection is included with the unit compressors (except EAC/R 1804 SM models)

ASTP Protection:

This device protects the compressor against high discharge temperatures.

When the temperature reaches critical values, ASTP protection causes "Scrolls" are separated. Compressor may stop pumping with motor running.

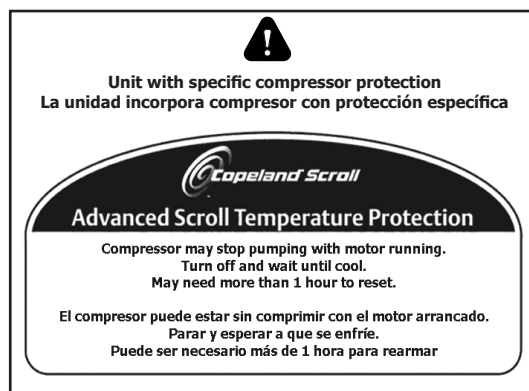

- Occasionally, when compressor stops and starts, there is a metallic noise because of spirals of the compressor. This is normal.
- Check compressor oil level, sight glass included (on the sides of the compressor, the level should be between 1/4 and 3/4 in the sight glass, while during operation the level should be between 3/4 and full).
- Connect high and low pressure gauges and check that operating pressure values are normal.
- Measure electrical consumption for the unit and check that it is near what is indicated on the specification plate.
- Check the electrical consumption of the compressor and the fans with what is specified in the physical data sheets.
- In the case of a Heat Pump unit, make a cycle change on the Control Panel checking that the 4-way valve makes the change correctly. Check the pressure values in the new cycle.
- Remember the low pressure switch is reset automatically and the high pressure switch is reset manually.
- Remember that low pressure switch is automatic reset, if it has 3 operations in one hour, it will be a manual reset, through the control of the unit.

3.- COMMISSIONING AND OPERATION

3.2.- CHECKING THE WATER FLOW RATE

It is very important that the unit operates at the correct water flow rate. It is dangerous to leave the unit operating at a low flow rate as this could result in serious damage to components as well as the water exchanger. If the unit operates at too high a flow rate, this will also hinder optimum performance. The best way of determining the operating flow rate is to measure the temperature difference between the inlet and water outlet.

Checking the water flow rate (it is vital to measure the thermal peak) (Standard unit)

For nominal and minimum water flow the difference between the inlet and water outlet temperature should be 5°C (cooling and heating pump units in cooling cycle only) for an inlet temperature of 12°C, an outlet temperature of 7°C and an outside temperature of 35°C. If these conditions change, the unit capacity will also change and as a result for nominal flow the difference between the inlet and water outlet temperature will vary slightly from 5°C as can be seen in the following table, based on nominal flow rate.

Water output °C	ΔT (Water inlet temperature - Water outlet temperature)						
	Outside temperature °C						
	15	20	25	30	35	40	45
7	6,1	5,8	5,5	5,3	5,0	4,7	4,4
9	6,5	6,2	5,9	5,6	5,3	5,0	4,7
11	7,0	6,7	6,4	6,0	5,7	5,4	5,0

If the unit must be started in the heating cycle and if you wish to operate at nominal cooling rate, the following shows the approximate differences between the inlet and water outlet temperatures for the various conditions.

Water output °C	ΔT (Water inlet temperature - Water outlet temperature)				
	Outside Temperature °C BH				
	-6	0	6	12	18
35	4,5	5,5	6,5	7,5	8,5
50	4	5	6	7	8

Note:

The unit control system displays the inlet and water outlet temperature to be displayed. See the Control Description section.

Check that the correct water pump has been selected, taking into account the loss of pressure in the hydraulic system. It is dangerous to let the unit run at a low rate and any faults which may result will not be covered under warranty.

Do not start up the air conditioning units or the fan coils until the water temperature reaches the set temperature or use an automatic control device which cancels the air conditioning unit operation if the installation is not properly set.

When everything is operating normally, take a reading of all the data and **fill out the Commissioning Sheet**.

3.- COMMISSIONING AND OPERATION

3.3.- CORROSION RESISTANCE OF COPPER AND STAINLESS STEEL OF PLATES EXCHANGER (WATER EXCHANGER)

GUIDE TO MEASURE A ANALYSIS OF THE WATER IN THE CIRCUIT.

The resistance guide below is an attempt of give a picture of the corrosion resistance of the stainless steel of the type AISI 316 and pure copper in the water, to a number of important chemical factors. The actual corrosion is however a very complex process influenced by many factors in combination. This table is therefore a considerable simplification and should not be overvalued.

Explanations:

- + Good resistance under normal conditions
- 0 Corrosion problems can occur especially when the factors are valued as 0
- Use is not recommended

WATER CONTAINING	CONCENTRATION mg/l ó ppm	AISI 316	COPPER
Alcalinity (HCNO ₃)	<70	+	0
	70-300	+	+
	>300	+	0
Sulfate (SO ₄ ²⁻)	<70	+	+
	70-300	+	-
	>300	0	-
HCO ₃ / SO ₄ ²⁻	>1.0	+	+
	<1.0	+	-
Electrical conductivity	<10µS/cm	+	0
	10-500µS/cm	+	+
	>500µS/cm	+	0
pH	<6.0	0	0
	6.0-7.5	0/+	0
	7.5-9.0	+	+
	>9.0	+	0
Amonium (NH ₃)	<2	+	+
	2-20	+	0
	>20	+	-
Chloroides (Cl ⁻)	<50	+	+
	>50	0	0
Free chlorine (Cl ₂)	<1	+	+
	1-5	+	0
	>5	0/+	-
Hydrogen sulfide (H ₂ S)	<0.05	+	+
	>0.05	+	-
Free(aggressive) Carbon Dioxide (CO ₂)	<5	+	+
	5-20	+	0
	>20	+	-
Total hardness (°dH)	4.0-8.5	+	+
Nitrate (NO ₃)	<100	+	+
	>100	+	0
Iron (Fe)	<0.2	+	+
	>0.2	+	0
Aluminium (Al)	<0.2	+	+
	>0.2	+	0
Manganese (Mn)	<0.1	+	+
	>0.1	+	0

4.- MAINTENANCE

4.1.- PREVENTIVE MAINTENANCE



PREVENTIVE MAINTENANCE PREVENTS COSTLY REPAIRS.

We recommend regular and thorough servicing of the LENNOX unit. It is therefore advisable to ask your dealer about maintenance contracts. Check maintenance of the following points (depending on the operating conditions maintenance every 6 months may be necessary).

Local legislation always takes precedence.

-- GENERAL STATE OF THE CASING:

Casing, paint, deterioration due to bumps, rust spots, leveling and supporting, state of the antivibration mounts, if installed, screwed panels, etc.

- ELECTRICAL CONNECTIONS:

State of cables, tightness of screws, grounding, current draw of the compressor and fans and checking that the unit is receiving the correct voltage.

- COOLING CIRCUIT:

Check that pressure values are correct and that there are no leaks. Check that there is no damage to the pipe insulation, that the state of the batteries is correct and that there are no chips or clogs retained by the air flow, etc.

- COMPRESSOR:

Inspect the oil level, if sight glass is present.

Inspect the state of the compressor mountings.

- FANS:

Check that fans turn freely and in the correct direction without excessive noises.

- CONTROL:

Check Set Points and normal operation.

- WATER:

If the installation contains anti-freeze, regularly check the state of the anti-freeze as well as the cleanliness of the water.

- WATER FILTER:

Clean the water inlet filter if necessary.

- WATER PUMP:

When the installation is going to work with percentages of glycol up to 20% and water temperatures below -5°C , even do we use a specific closing for the water pump, it is advisable to clean the water pump's closing every year and a half, in order to avoid leaks by crystallization.

- PLATE EXCHANGER:

Prove the general isolation state and tightness of the water connections.

- CHECK FOR REFRIGERANT LEAKAGE AND WATER LEAKAGE.

4.2.- CORRECTIVE MAINTENANCE



IMPORTANT MAKE SURE THAT THE UNIT IS COMPLETELY DISCONNECTED FROM THE POWER SUPPLY WHEN CARRYING OUT ANY TYPE OF WORK ON THE MACHINE

If some component in the cooling circuit must be replaced, follow these recommendations:

- Always use original replacement parts.
- Regulation prohibits the release on the refrigerant into the atmosphere.
- If cuts must be made in the pipe work, use pipe cutters. Do not use saws or any other tools that produce filings.
- All brazing must be carried out in a nitrogen atmosphere to prevent corrosion from forming.
- Use silver alloy brazing rod.
- Take special care that the flame from the torch is aimed in the opposite direction from the component to be welded and is covered with a wet rag in order to avoid overheating.

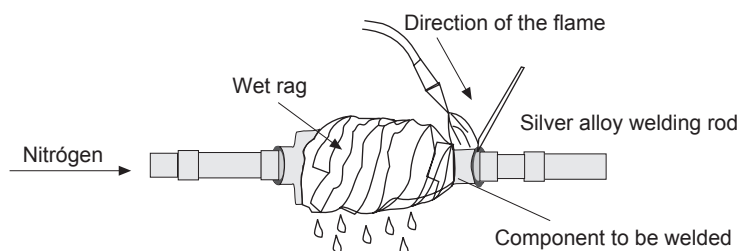

4.- MAINTENANCE

4.2.- CORRECTIVE MAINTENANCE

- Take very special care if 4-way check valves are to be replaced since these have internal components that are very heat-sensitive such as plastic, teflon, etc.
- If a compressor must be replaced, disconnect it electrically and un-braze the suction and discharge lines. Remove the securing screws and replace the old compressor with the new one. Check that the new compressor has the correct oil charge, screw it to the base and connect the lines and electrical connections.
- Carry out the vacuum above and below through the Schrader valves of the outdoor unit until -750 mm Hg is reached. Once this level of vacuum has been reached, keep the pump in operation for at least one hour. **DO NOT USE THE COMPRESSOR AS A VACUUM PUMP.** If the compressor runs in vacuum it will fail.
- Charge the unit with refrigerant according to the data on the Rating Plate for the unit and check that there are no leaks.



PRECAUTIONS TO BE TAKEN IN THE USE OF R-410A REFRIGERANT

If R-410A Refrigerant is used in the unit, the following precautions characteristic of this gas should be taken:

- The Vacuum Pump must have a Check Valve or Solenoid Valve.
- Pressure Gauges and Hoses for the exclusive use with R-410A Refrigerant should be used.
- The charge should be carried out in the Liquid Phase.
- Always use scales to weight-in charge
- Use the Leak Detector exclusive for R-410AC Refrigerant.
- Do not use mineral oil, only synthetic oil to ream, expand or make connections.
- Keep pipes capped before using them and be very thorough about any possible moisture and dirt (dust, filings, burrs, etc.).
- Brazing should always be carried out in a nitrogen atmosphere.
- Reamers should always be well sharpened.
- The refrigerant bottle must contain at least 2 % of the total amount .

4.3.- FAILURE DIAGNOSIS

PROBLEM	CAUSE	ACTION
The unit does not start after the last start.	<ul style="list-style-type: none"> * Disconnected supply. * Main switch set to STOP. * No water flow. * Fuses are broken. * Low electrical supply. * One of the safety devices has been activated. * Compressor fault. * Low water temperature. 	<ul style="list-style-type: none"> * Check electrical supply. * Connect main switch. * Start water pump (and check air in system). * Check voltage. * Check antifreeze thermostat. * Check high/low pressure switch. * Change compressor. * Create demand for cooling.
The fan does not work (although the compressor is operating).	<ul style="list-style-type: none"> * Internal safety device open. * Bad connection. * Poor condensation control. 	<ul style="list-style-type: none"> * Let the motor cool. * Connect properly. * Check operation.
The compressor stops when the high pressure switch is cut off.	<ul style="list-style-type: none"> * Condenser coil blocked. * Unit operating outside of limiting. * Abnormal operation of the fans. 	<ul style="list-style-type: none"> * Maintain condenser coil. * Check the ventilators.
The compressor stops when the low pressure switch is cut off.	<ul style="list-style-type: none"> * Insufficient charge. * The water exchanger is blocked (water side). * No water flow. 	<ul style="list-style-type: none"> * Check the charge. * Maintain the exchanger. * Check that there is sufficient water flow.
The oil level in the compressor is very low.	<ul style="list-style-type: none"> * The crank case heater is not working. 	<ul style="list-style-type: none"> * Replace the crank case heater and check oil level.
High noise level of compressor and high and low pressures are abnormal.	<ul style="list-style-type: none"> * Phase connection for compressor power supply incorrectly. 	<ul style="list-style-type: none"> * Switch the wires between two of the phases of compressor power supply.

NOTES



www.lennox europe.com

BELGIUM, LUXEMBOURG
www.lennoxbelgium.com

CZECH REPUBLIC
www.lennox.cz

FRANCE
www.lennoxfrance.com

GERMANY
www.lennoxdeutschland.com

GREAT BRITAIN
www.lennoxuk.com

NETHERLANDS
www.lennoxnederland.com

POLAND
www.lennoxpolska.com

PORTUGAL
www.lennoxportugal.com

RUSSIA
www.lennoxrussia.com

SLOVAKIA
www.lennoxdistribution.com

SPAIN
www.lennoxspain.com

UKRAINE
www.lennoxrussia.com

OTHER COUNTRIES
www.lennoxdistribution.com

Due to Lennox's ongoing commitment to quality, the Specifications, Ratings and Dimensions are subject to change without notice and without incurring liability.

Improper installation, adjustment, alteration, service or maintenance can cause property damage or personal injury.

Installation and service must be performed by a qualified installer and servicing agency.



MIL85E-0907 09-2007