

SERVICE UNIT INFORMATION CHA8

Litho U.S.A.

CHA8 SERIES UNITS

I - INTRODUCTION

CHA8 packaged air conditioning units are designed primarily for rooftop installation with the RMF3 roof mounting frame, but they can be installed for slab mounting with end discharge. Figure 1 shows a cutaway. Auxiliary electric heat is available (ECH8). Other options are listed under "Accessories."

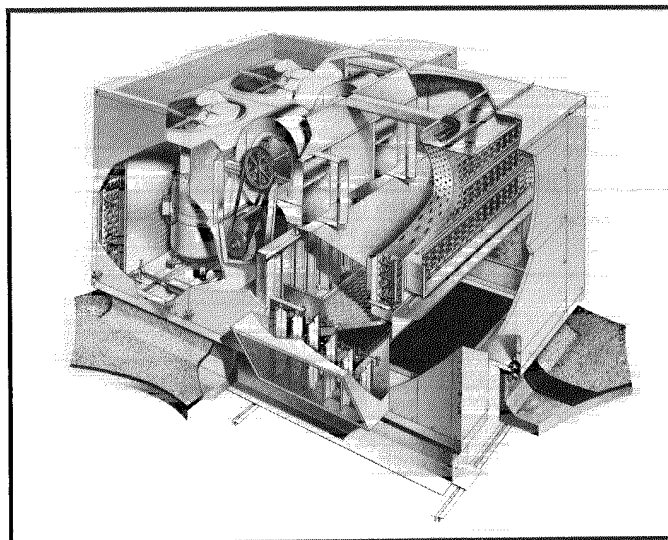

FIGURE 1

II - UNIT INFORMATION

A - Accessories

Accessory Description	Accessory Order No. & Net Weight (lbs.)			
	CHA8-953	CHA8-1353	CHA8-1853	CHA8-2753
POWER SAVER and No. & size of filters (in.)	RD3-95 (275 lbs.) (2) 20 x 25 x 1	RD3-135 (360 lbs.) (4) 16 x 25 x 1	RD3-185 (510 lbs.) (3) 20 x 36 x 1	RD3-275 (606 lbs.) (4) 20 x 36 x 1
Minimum fresh air damper and No. & size of filters (in.)	OAD3-95 (38 lbs.) (1) 16 x 20 x 1	OAD3-135 (60 lbs.) (1) 20 x 20 x 1	OAD3-185 (101 lbs.) (1) 25 x 27 x 1	OAD3-275 (107 lbs.) (1) 26 x 31 x 1
Automatic Kit for OAD3 Damper	BM-5563 (9 lbs.)	BM-5563 (9 lbs.)	BM-5563 (9 lbs.)	BM-5563 (9 lbs.)
RP2-1 Remote Readout Panel	BM2-5358 (5 lbs.)	BM2-5358 (5 lbs.)	BM2-5358 (5 lbs.)	BM2-5358 (5 lbs.)
RP2-00-1 Rough-in Box	BM1-5358 (3 lbs.)	BM1-5358 (3 lbs.)	BM1-5358 (3 lbs.)	BM1-5358 (3 lbs.)
Remote Readout Panel Kit	BM-5893 (5 lbs.)	BM-5893 (5 lbs.)	BM-5893 (5 lbs.)	BM-5893 (5 lbs.)
Low Ambient Control Kit	LB-80249BB (8 lbs.)	LB-80249BB (8 lbs.)	LB-80249BA (8 lbs.)	LB-80249BA (8 lbs.)
Hot Gas Bypass Kit	BM-4310 (10 lbs.)	BM-4311 (10 lbs.)	----	----
Roof Mounting Frame	RMF3-95 (100 lbs.)	RMF3-135 (140 lbs.)	RMF3-185/275 (200 lbs.)	RMF3-185/275 (200 lbs.)
Combination Ceiling Supply and Return Kit	BM-3564 (20 lbs.)	BM-3565 (29 lbs.)	BM-3566 (40 lbs.)	BM-3567 (43 lbs.)
Combination Ceiling Supply And Return Step Down Diffuser	RTD-95 (60 lbs.)	RTD-135 (118 lbs.)	RTD-185/275 (172 lbs.)	RTD-185/275 (172 lbs.)
Combination Ceiling Supply And Return Flush Diffuser	FD-95 (50 lbs.) *FD-95-D (50 lbs.)	FD-135 (60 lbs.) *FD-135-D (60 lbs.)	FD-185 (64 lbs.) *FD-185-D (64 lbs.)	FD-275 (69 lbs.) *FD-275-D (69 lbs.)
End Supply & Return Air Discharge Kit	----	----	LB-44878CA (20 lbs.)	LB-44877CA (25 lbs.)
Blower powered mixing damper boxes	ZDB1-400 (52 lbs.), ZDB1-800 (74 lbs.), ZDB1-1200 (103 lbs.), & ZDB1-1600 (114 lbs.)			

*Flush diffuser with adjustable baffle blades.

B - Electrical Data

Model No.		CHA8-953				CHA8-1353				CHA8-1853				CHA8-2753			
Line voltage (60 Hz — 3 ph)		208/230		460		208/230		460		208/240		440/480		208/240		440/480	
Compressor(s)	RLA (total)	31.8		14.6		46.7		22.8		64.6		29.2		85.6		41.2	
	LRA (total)	185.0		93.0		240.0		128.0		370.0		186.0		480.0		256.0	
	Power factor	.85		.85		.85		.85		.85		.85		.85		.85	
Condenser	FLA (total)	6.0		*3.0		8.0		*4.0		8.6		4.3		8.6		4.3	
Fan motors (2)	LRA (total)	19.0		19.0		19.0		19.0		43.2		21.6		43.2		21.6	
Evaporator Blower Motor	Horsepower	2	3	2	3	3	5	3	5	3	5	3	5	5	7-1/2	5	7-1/2
	FLA	6.2	10.0	3.1	5.0	10.0	14.6	5.0	7.3	9.4	14.6	4.7	7.3	14.6	21.0	7.3	10.5
	LRA	44.0	64.0	22.0	32.0	64.0	92.0	32.0	46.0	64.0	92.0	32.0	46.0	92.0	140.0	46.0	70.0
Recommended Maximum Fuse Size (amps)		80	80	35	40	110	125	60	60	110	125	50	50	150	150	70	80
†Minimum Circuit Ampacity		53.3	56.4	24.7	26.1	77.0	83.1	37.3	40.1	91.1	97.3	41.2	44	120.9	128.4	57.5	60.9

*Motors are rated at 230v, FLA shown is for step down transformer.

†Refer to National Electrical Code manual to determine wire, fuse and disconnect size requirements.

NOTE — Extremes of operating range are plus and minus 10% of line voltage.

C - Specifications

Model No.		CHA8-953	CHA8-1353	CHA8-1853	CHA8-2753
*Cooling Capacity @ARI Standard Conditions	Total capacity (Btuh)	196,000	1130,000	200,000	273,000
	Total unit watts	12,700	17,100	25,000	35,500
	Dehumidifying capacity	26%	28%	29%	26%
Refrigerant charge (R-22)		16 lbs.	17 lbs.	40 lbs.	48 lbs.
Blower wheel nom. diam. x wid. (in.)		(2) — 12 x 6	(2) — 15 x 9	(2) — 15 x 11	(2) — 15 x 15
Blower Motor Hp See Drive Selection Table	Minimum	2	3	3	5
	Maximum	3	5	5	7-1/2
Condenser Coil	Net face area (sq. ft.)	10.2	13.8	(2) 10.75 ea.	(2) 12.15 ea.
	Tube diam. (in.) & No. of rows	3/8 — 4	3/8 — 4	1/2 — 4	1/2 — 6
	Fins per inch	18	18	13	13
Condenser Fan	Diam. (in.) & No. of blades	(2) 22 — 5	(2) 22 — 5	(2) 25-1/2 — 6	(2) 25-1/2 — 6
	Air volume (cfm)	6000	7550	13,500	13,250
	Motor hp	(2) 1/2	(2) 3/4	(2) 1	(2) 1
	Watts input (total)	1100	1640	2820	2500
Evaporator Coil	Net face area (sq. ft.)	7.4	9.4	(2) 7.67 ea.	(2) 8.75 ea.
	Tube diam. (in.) & No. of rows	3/8 — 4	3/8 — 4	1/2 — 4	1/2 — 4
	Fins per inch	13	13	13	13
No. & size of filters (in.)		(1) 20 x 25 x 1 (2) 16 x 25 x 1	(6) 16 x 20 x 1	(4) 20 x 20 x 1 (4) 16 x 20 x 1	(8) 20 x 20 x 1
Condensate drain size MPT (in.)		3/4	1	1-1/4	1-1/4
Net weight of basic unit (lbs.)		1425	1860	2785	3280

*Rated in accordance with ARI Standard 210, 450 CFM (maximum) evaporator air volume per ton of cooling, 95F outdoor air temperature and 80 db/67 wb entering evaporator air.

†ARI Standard 210 ratings.

D - Dimensions

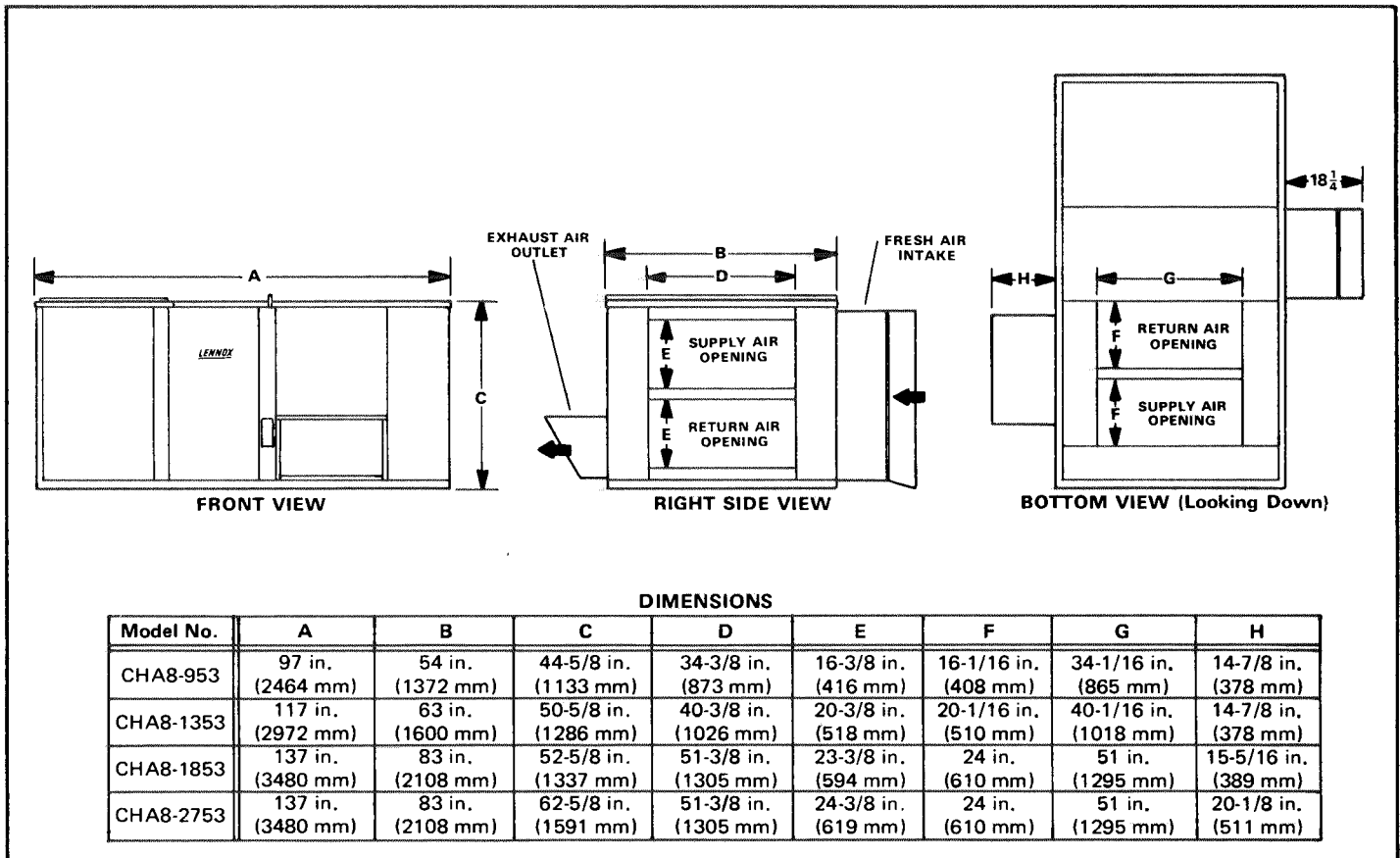

E - Blower Data

Air Volume (Cfm)	STATIC PRESSURE EXTERNAL TO UNIT (Inches Water Gauge)											
	0	.10	.20	.30	.40	.50	.60	.70	.80	.90	1.0	
	RPM BHP	RPM BHP	RPM BHP	RPM BHP	RPM BHP	RPM BHP	RPM BHP	RPM BHP	RPM BHP	RPM BHP	RPM BHP	RPM BHP
CHA8-953 BLOWER PERFORMANCE CHART												
2600	700 .70	750 .80	795 .90	840 1.00	880 1.07	920 1.15	960 1.25	995 1.35	1030 1.45	1065 1.55	1100 1.70	
2800	750 .90	800 1.00	845 1.10	885 1.20	925 1.30	960 1.40	1000 1.50	1035 1.60	1070 1.70	1100 1.80	1130 1.90	
3000	810 1.10	850 1.20	890 1.30	930 1.40	970 1.50	1005 1.60	1040 1.75	1075 1.85	1110 1.95	1140 2.05	1170 2.15	
3200	860 1.30	900 1.40	940 1.55	980 1.65	1015 1.75	1050 1.90	1080 2.00	1115 2.15	1145 2.25	1175 2.35	1210 2.50	
3400	915 1.55	950 1.70	990 1.80	1025 1.95	1060 2.05	1090 2.15	1125 2.30	1150 2.40	1185 2.50	1215 2.65	1245 2.80	
3600	970 1.85	1005 2.00	1045 2.15	1075 2.25	1105 2.40	1135 2.50	1165 2.65	1195 2.80	1225 2.90	1255 3.00	1285 3.15	
3800	1020 2.20	1050 2.35	1085 2.45	1120 2.60	1150 2.75	1180 2.90	1210 3.05	1240 3.15	1270 3.30	1300 3.45	----	----
CHA8-1353 BLOWER PERFORMANCE CHART												
3800	555 1.00	600 1.15	640 1.30	680 1.45	725 1.60	765 1.85	800 2.05	835 2.25	----	----	----	----
4000	585 1.20	625 1.35	665 1.50	705 1.65	745 1.85	780 2.00	815 2.20	850 2.45	890 2.65	----	----	----
4200	615 1.40	650 1.50	690 1.65	730 1.85	770 2.05	800 2.25	835 2.50	870 2.70	905 2.90	935 3.15	----	----
4400	645 1.60	680 1.75	720 1.90	755 2.10	790 2.30	825 2.55	855 2.70	890 2.90	925 3.20	955 3.45	985 3.65	
4600	675 1.80	710 2.00	745 2.15	780 2.35	815 2.60	845 2.80	880 3.00	910 3.20	945 3.50	975 3.70	1005 3.95	
4800	700 2.05	740 2.25	770 2.40	805 2.65	835 2.80	865 3.00	900 3.25	930 3.50	965 3.75	995 4.00	1020 4.25	
5000	735 2.35	765 2.55	800 2.75	830 2.95	860 3.10	890 3.30	920 3.55	950 3.75	985 4.10	1015 4.30	1040 4.55	
5200	765 2.65	795 2.85	825 3.05	855 3.25	885 3.45	915 3.60	945 3.85	975 4.15	1005 4.35	1035 4.60	1060 4.90	
5400	795 2.95	820 3.15	850 3.35	880 3.55	910 3.75	940 4.00	965 4.25	995 4.45	1025 4.75	1050 5.00	1080 5.30	
5600	825 3.30	850 3.45	880 3.70	905 3.90	930 4.10	960 4.30	990 4.50	1015 4.75	1045 5.05	1070 5.35	1095 5.60	
CHA8-1853 BLOWER PERFORMANCE CHART												
5000	490 .95	530 1.15	570 1.30	605 1.40	635 1.55	670 1.70	700 1.85	730 2.00	760 2.15	785 2.30	815 2.50	
5500	540 1.30	575 1.45	615 1.65	645 1.80	675 1.95	705 2.10	735 2.25	765 2.40	790 2.60	820 2.80	840 2.95	
6000	590 1.70	620 1.85	650 2.00	685 2.20	715 2.40	740 2.60	775 2.80	800 3.00	825 3.15	850 3.30	875 3.50	
6500	640 2.15	670 2.35	700 2.55	725 2.70	750 2.85	780 3.05	810 3.30	835 3.50	860 3.65	885 3.85	910 4.10	
7000	685 2.65	715 2.90	740 3.10	770 3.30	800 3.50	825 3.70	850 3.90	875 4.15	900 4.35	920 4.55	940 4.75	
7500	735 3.25	765 3.45	790 3.70	815 3.95	840 4.15	865 4.35	890 4.60	910 4.80	930 5.00	955 5.25	980 5.55	
CHA8-2753 BLOWER PERFORMANCE CHART												
6500	530 1.40	570 1.60	605 1.80	640 1.95	675 2.15	705 2.35	730 2.55	760 2.75	785 2.95	810 3.10	835 3.30	
7000	570 1.80	605 1.95	640 2.15	675 2.35	705 2.55	735 2.75	760 2.95	790 3.15	815 3.35	840 3.55	865 3.85	
7500	615 2.20	645 2.40	675 2.60	705 2.80	735 3.00	765 3.20	795 3.45	820 3.65	845 3.90	870 4.10	895 4.35	
8000	650 2.65	680 2.85	715 3.10	745 3.30	770 3.50	800 3.75	825 3.95	850 4.20	875 4.45	900 4.70	920 4.90	
8500	690 3.15	720 3.40	750 3.65	780 3.85	805 4.10	830 4.30	855 4.55	880 4.80	905 5.10	930 5.35	950 5.55	
9000	730 3.80	760 4.05	790 4.30	815 4.50	840 4.75	865 5.05	890 5.25	915 5.50	940 5.80	960 6.05	980 6.25	
9500	775 4.55	800 4.75	825 5.00	850 5.20	875 5.45	900 5.75	925 6.05	950 6.30	970 6.55	990 6.80	1015 7.15	
10,000	815 5.25	840 5.50	860 5.70	885 6.00	915 6.30	935 6.55	960 6.85	980 7.15	1000 7.40	1020 7.65	1040 7.95	

F - Pressure Curves

NORMAL OPERATING PRESSURE CURVE FOR CHA8-953 SERIES

DISCHARGE PRESSURE - Kg/cm²

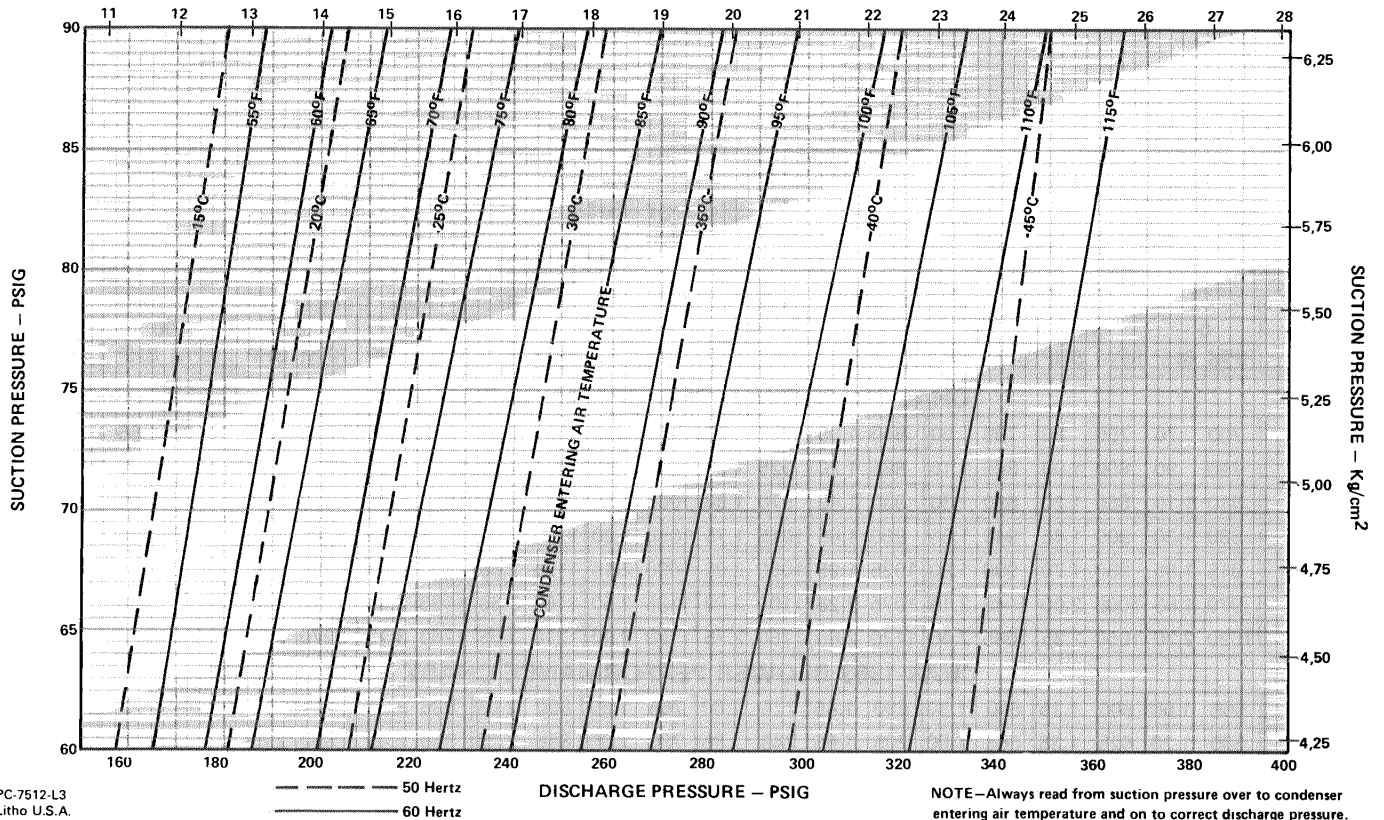

PC-7512-L3
Litho U.S.A.

NORMAL OPERATING PRESSURE CURVE FOR CHA8-1353 SERIES UNITS

DISCHARGE PRESSURE - Kg/cm²

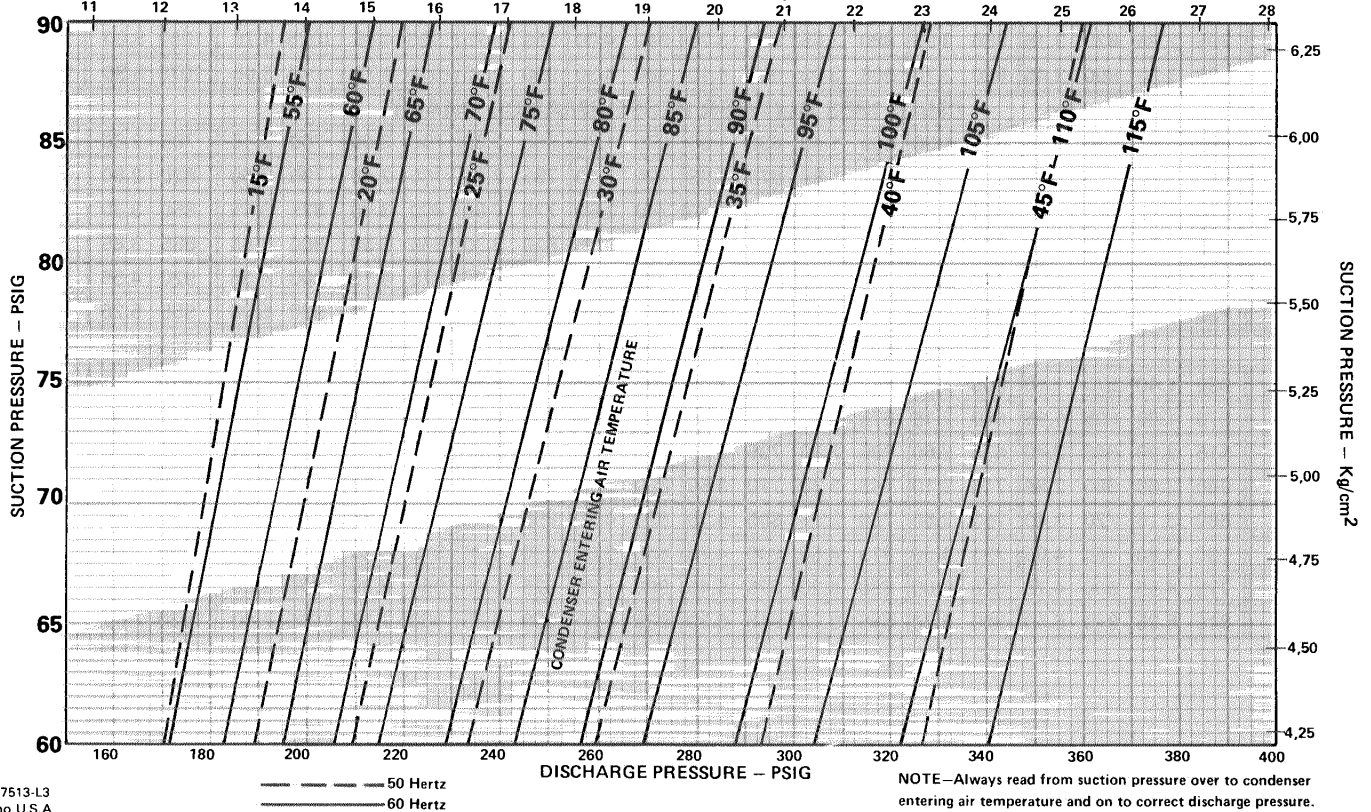

PC-7513-L3
Litho U.S.A.

NORMAL OPERATING PRESSURE CURVE FOR CHA8-2753 SERIES UNITS

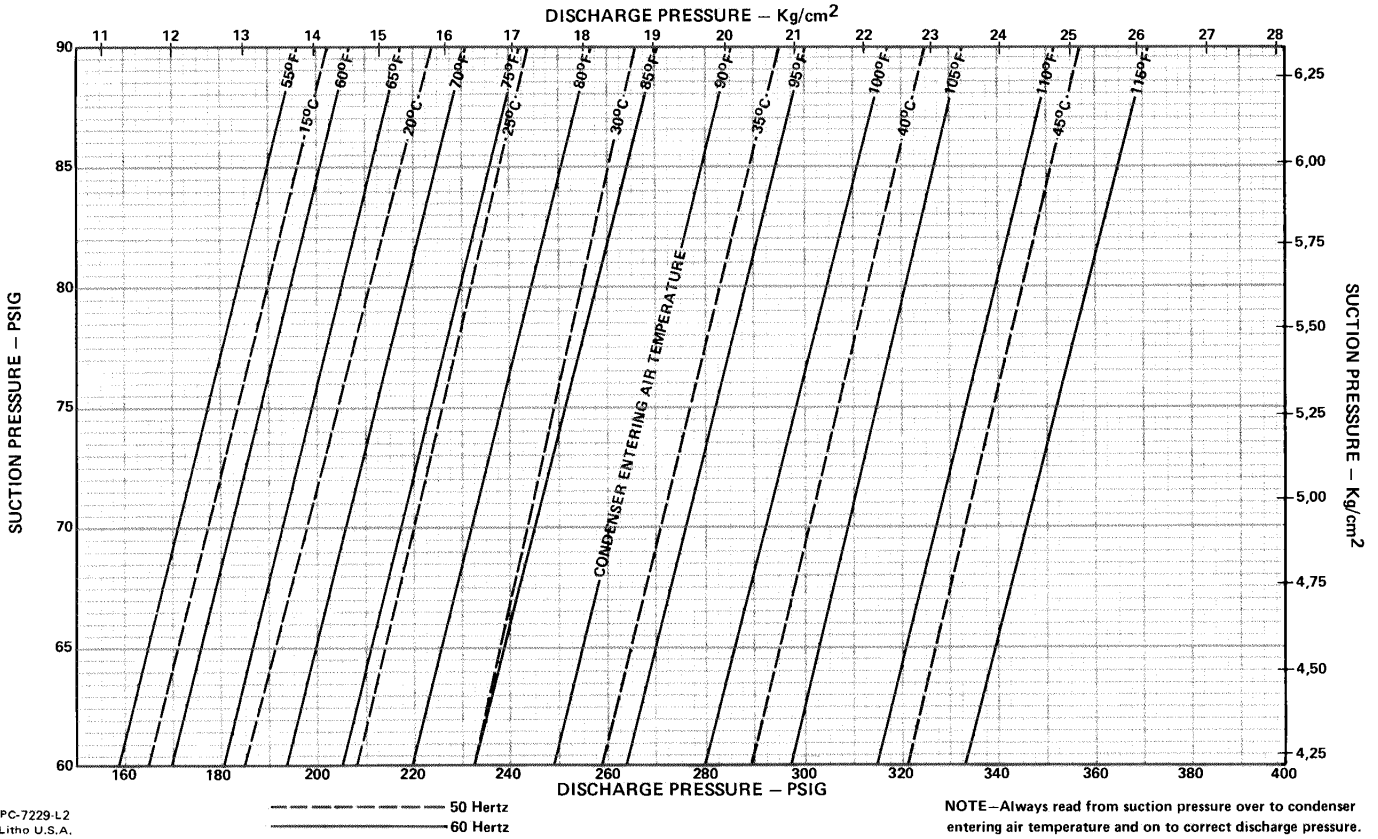

NORMAL OPERATING PRESSURE CURVE FOR CHA8-1853 SERIES UNITS

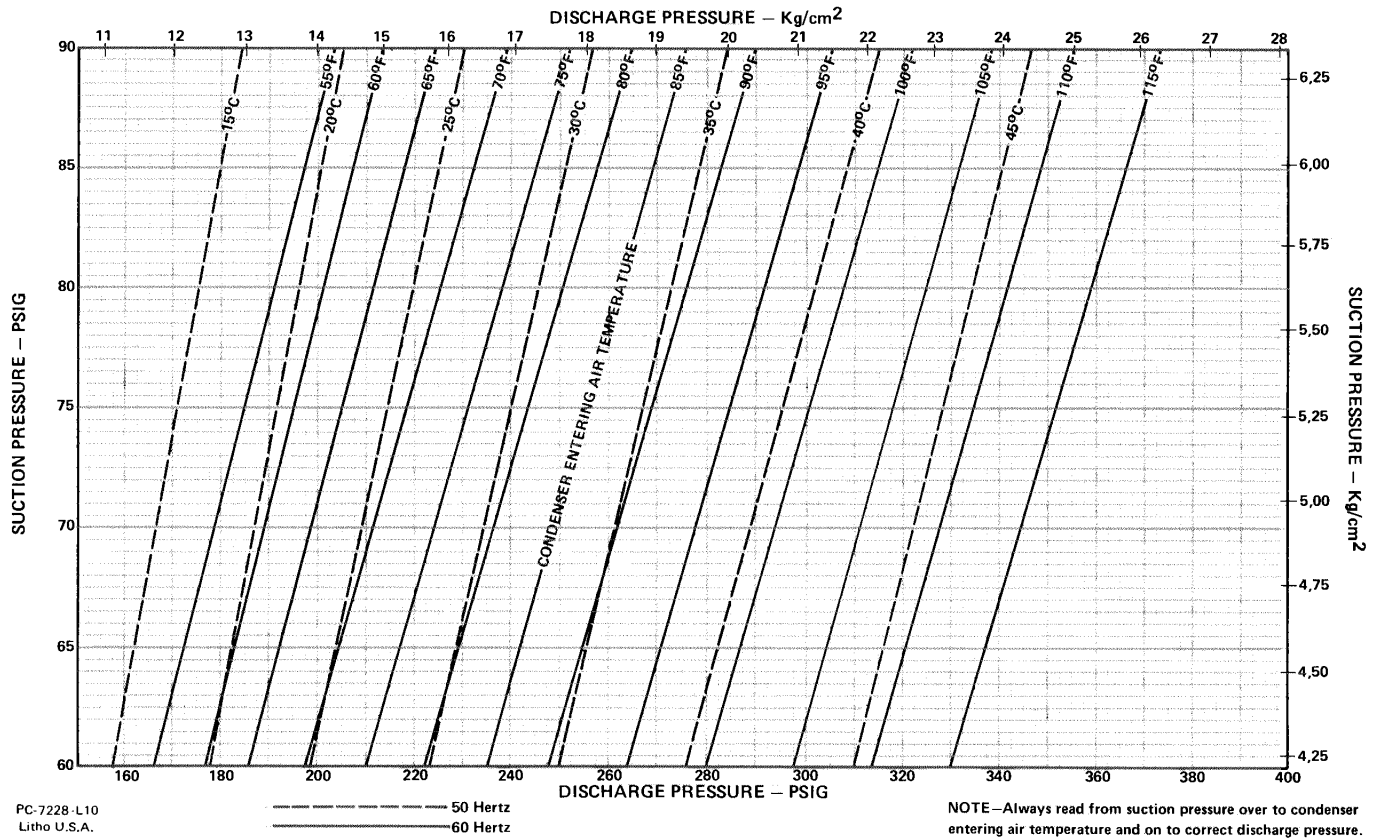

G - Voltage Field Wiring

Without ECH8

Connect line voltage power supply to CHA8 leads in high voltage junction box from a properly sized disconnect.

With ECH8

On units employing an ECH8-275, two disconnects are used

(one for the electric heater and one for the CHA8). Run supply wiring to the largest of the two disconnects.

On all other CHA8/ECH8 applications, run the supply wiring to the terminal block in the ECH8. Then route the 3 power leads from the CHA8 high voltage junction box to the ECH8 fuse block and connect. The fuses must be field provided. Refer to unit rating plate for maximum fuse size. Figure 2 shows the field hookup.

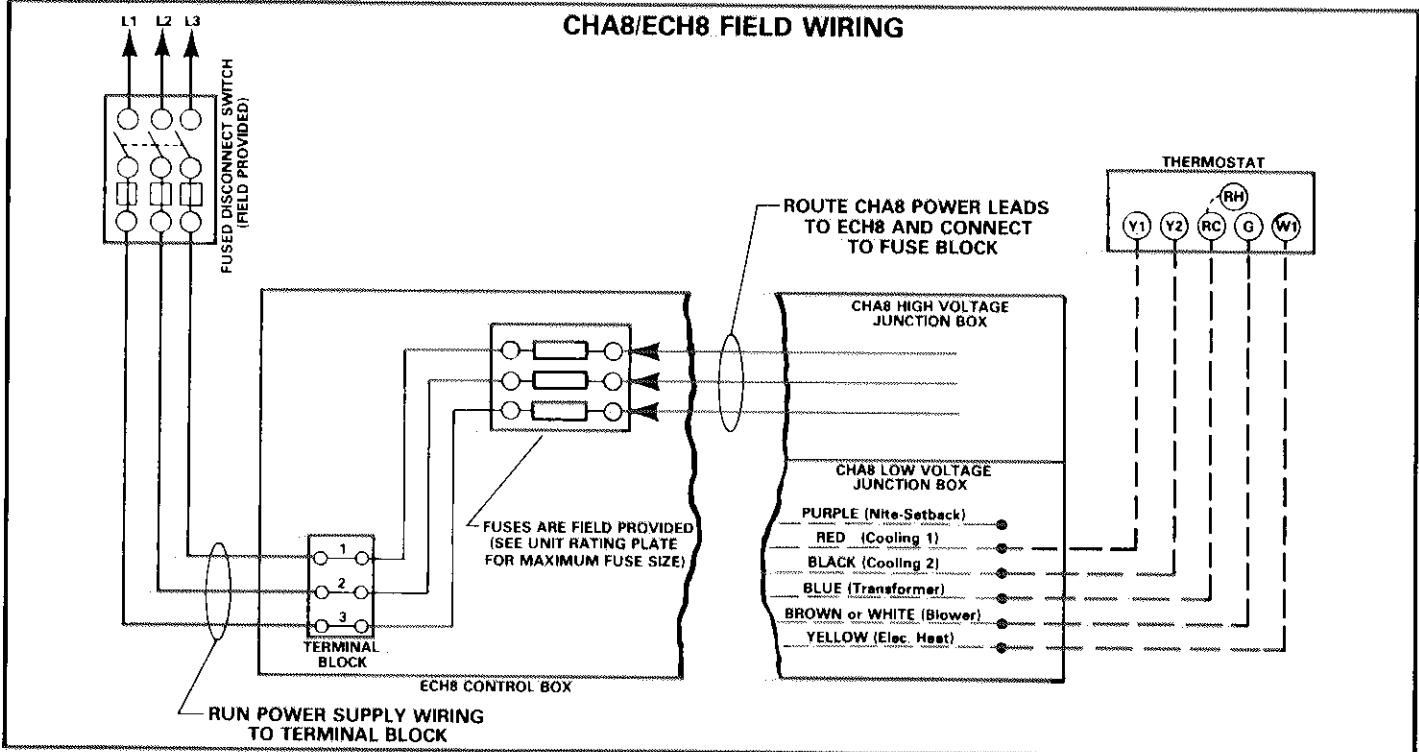

FIGURE 2

III - REFRIGERANT SYSTEM

CHA8-953 & 1353 units have a single L2 compressor in a single refrigeration system. CHA8-1853 & 2753 units have twin L2 compressors in separate refrigeration systems. Each system uses an expansion valve to meter the refrigerant. The element is field replaceable.

The suction and discharge service valves are located at compressor. See Figure 3. A liquid line service valve is inside cabinet. The gauge ports on service valves can be shut off by backseating the valves. Open valve one turn off backseat to record pressure at gauge manifold. The head pressure given on operating curves is based on discharge pressure. Always replace access panels and seal around gauge hoses when monitoring refrigerant pressures.

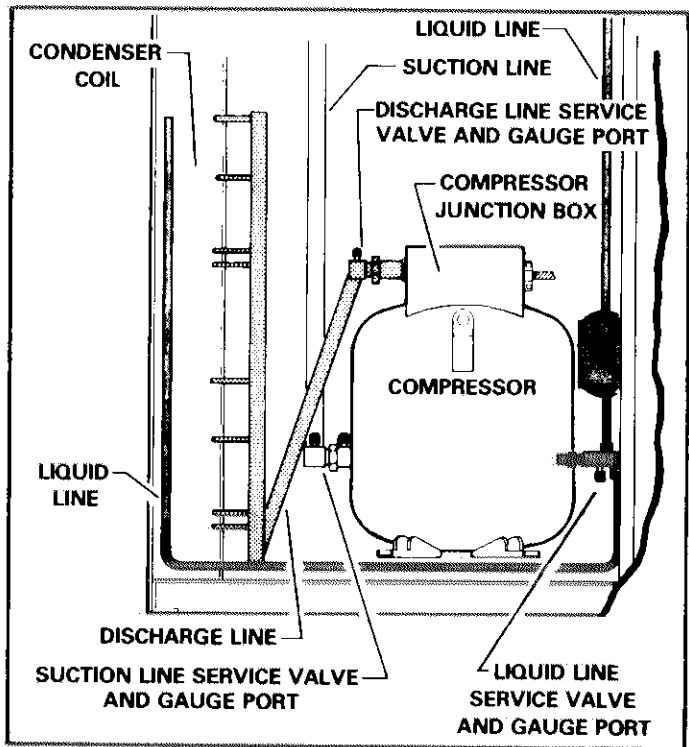

FIGURE 3

IV - COMPONENTS

A - Control Box

Figure 4 identifies the CHA8-953 & 1353 control box while Figure 5 identifies the CHA8-1853 & 2753. Table 1 lists the electrical components and then gives a brief description.

B - L2 Compressor

The compressor is protected by a series of controls located in the compressor make-up box which monitor the system.

TABLE 1

COMPONENT	DESCRIPTION
No. 1 Compressor Contactor	Energizes compressor number 1. Also on CHA8-953/1353 "Y" starts condenser fan motors.
No. 2 Compressor Contactor	Energizes compressor number 2.
Outdoor Fan Contactor	On all "J" and "G" voltages and CHA8-1853/2753-"L" voltage units, this contactor powers the condenser fans. On CHA8-953/1353 units the fan motors are 220V single phase. CHA8-1853/2753 units use three phase motors.
No. 1 Cool Relay	Initiates first stage cooling. Is activated by "Y1" leg of thermostat.
No. 2 Cool Relay	Initiates second stage cooling. Is activated by "Y2" leg of thermostat.
Power Saver Relay	Used on all but CHA8-1853/2753-L voltage units. Energizes power saver circuit. Is activated by "G" leg of thermostat.
Power Transformer	On "J" and "G" voltage units this transformer provides 220V control circuit.
Low Voltage Transformer	Provides 24V thermostat voltage
Timed Off Control	Prevents compressor short cycling and allows time for system pressure to equalize. Initially delays compressor operation for 20 seconds. It must run through a 5 minute cycle before it resets. If compressor runs less than 5 minutes, control will run through remaining time plus 20 seconds on next demand.

They shut down the compressor during abnormal operating conditions.

1 - Compressor Overloads (3)

These protectors are current sensitive and protect the compressor motor from single phasing (loose wiring) and locked rotor conditions.

2 - High Pressure Switch

Opens control circuit at 410 psig head pressure. Automatically resets.

3 - Ambient Thermostat

This thermostat opens control circuit at 22°F ambient and automatically resets at 32°F.

4 - Low Pressure Switch

Opens control circuit at 20 psig suction pressure and automatically resets at 50 psig.

5 - Fuses (2)

The 3 amp fuses protect the inwinding thermostat from damage.

6 - Internal Thermostat

This consists of 2 inwinding devices which protect the motor windings from overheating. It may take up to an hour for reset once tripped.

C - Condenser Coil

Air draws through the coil and is discharged through the top of unit. For fan service access, remove the bolts securing fan assembly Figure 6 illustrates the condenser fan and motor assemblies.

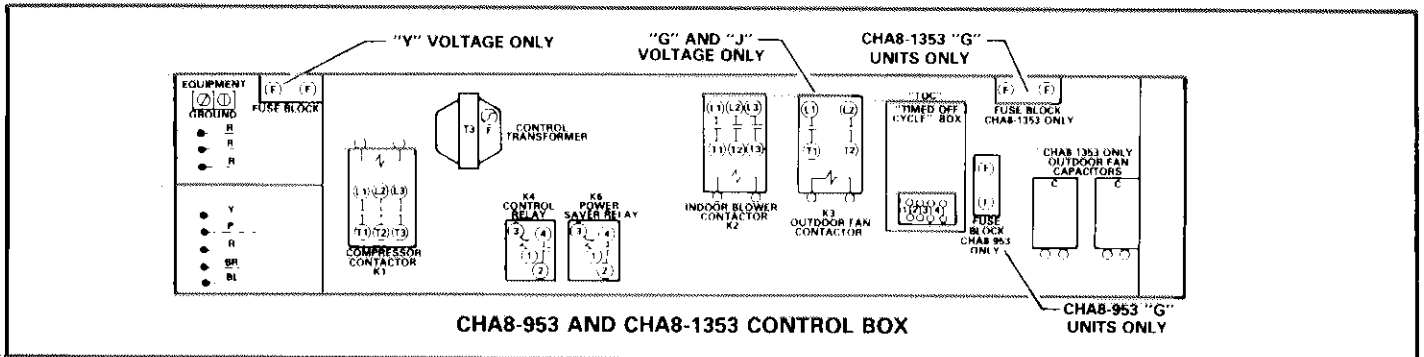

FIGURE 4

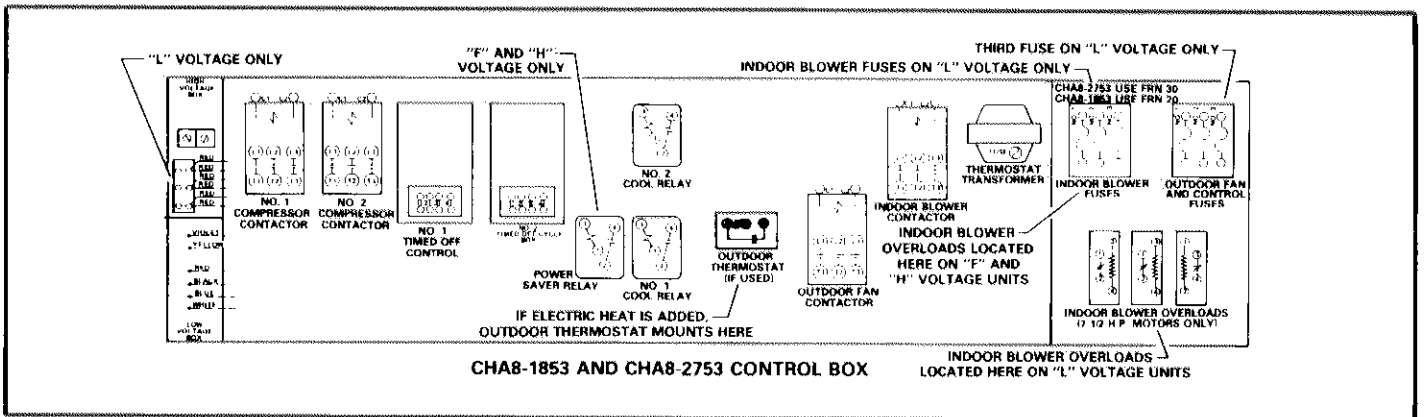

FIGURE 5

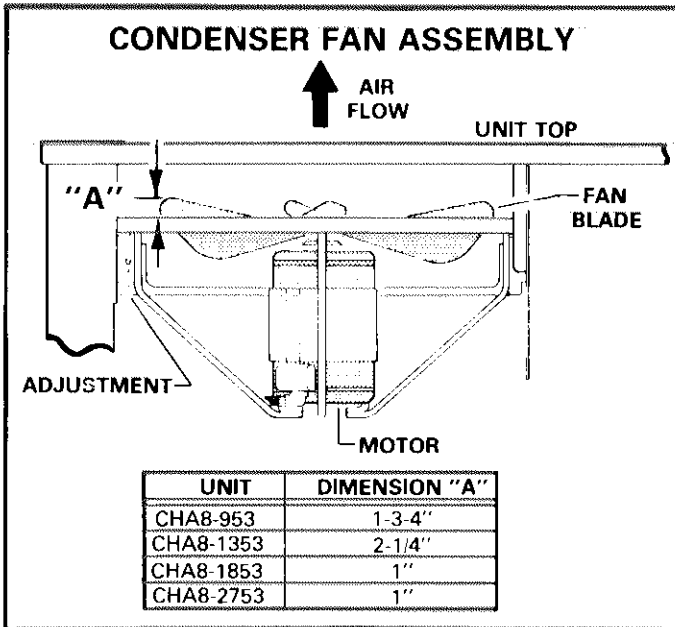

FIGURE 6

D - Blower Compartment

Table 2 lists the drive selection available for CHA8 series units. 7-1/2 H.P. motors are equipped with overloads. Figure 7 identifies the blower compartment.

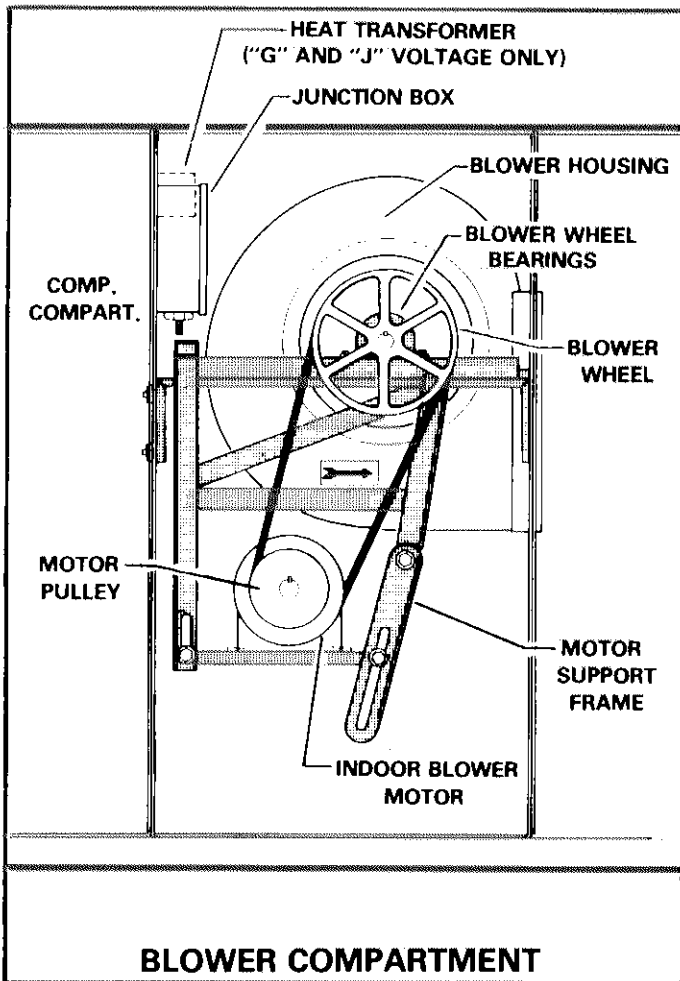

FIGURE 7

TABLE 2

Model No.	Nominal Motor Hp	Maximum Usable Hp	*Rpm Range Of All Available Drive Setups @ 1720 Rpm Motor Speed
CHA8-953	2	2.30	860-1200
	3	3.45	990-1200
CHA8-1353	3	3.45	765-955
	5	5.75	893-1087
CHA8-1853	3	3.45	720-875
	5	5.75	815-970
CHA8-2753	5	5.75	740-890
	7-1/2	8.63	830-980

E - Power Saver (Optional)

RD3 Power Savers are optional to CHA8 units. Refer to section 16.2 for additional information.

V - BLOWER SPEED ADJUSTMENT

A - Changing Blower Speed

The drive kit options are listed in Table 2. To change speed, refer to Figure 8. Loosen nut on motor base frame, slide motor up and remove belt. Loosen motor pulley with Allen wrench and adjust pulley according to detail in Figure 8. Be sure Allen screw is lined up with flat side of sheave before retightening.

B - Checking Evaporator Coil Air Pressure Drop

1 - Air test holes are provided (one each side of coil) for checking pressure drop across evaporator coil. This check should be made with an inclined monometer or draft gauge. See Figure 9.

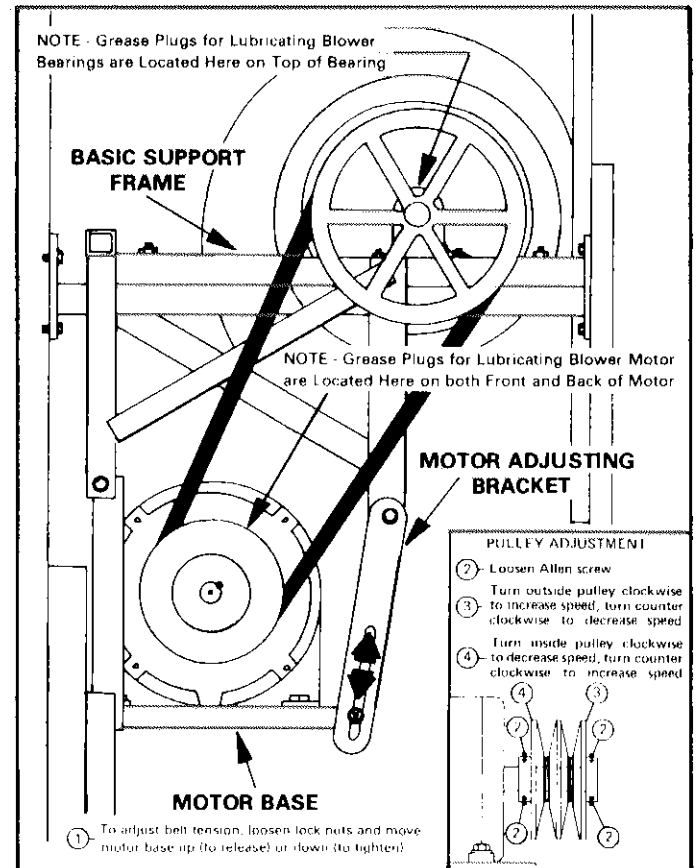

TABLE 3

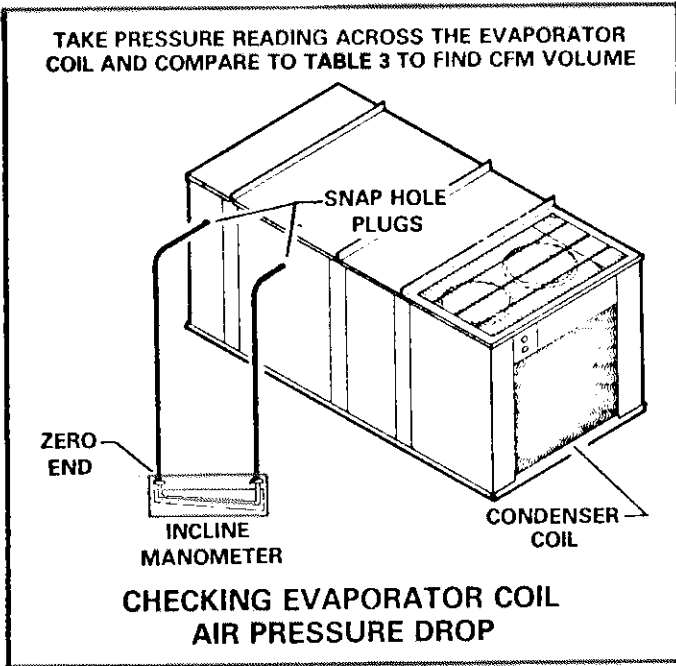

FIGURE 9

- 2 - Remove snaphole plugs and insert an awl or screwdriver to open insulation behind holes.
- 3 - Insert hoses from draft gauge into air test holes so about 1/4" extends inside cabinet. Zero end of draft gauge scale connects to entering side of coil. Seal around holes with permagum or sealing compound.
- 4 - To start evaporator blower motor, move thermostat heat selector to lowest setting. Move cooling selector to highest setting. Place system switch in "cool" or "auto" position and fan switch in "cont." position. Turn on power supply. Evaporator blowers only will operate.
- 5 - See Table 3 for air volumes and equivalent draft gauge readings. Observe draft gauge readings with evaporator blowers running. If reading is below air volume required, increase blower speed. If reading is above air volume required, decrease blower speed.
- 6 - After draft gauge reading is obtained, remove draft gauge lines and replace snaphole plugs. Turn off blower motor.

VI - MAINTENANCE

A - Lubrication

NOTE - Always relubricate motors according to manufacturers lubrication instructions on each motor. If no instructions are provided, use the following as guide:

- 1 - *Evaporator Blower Bearings* - Bearings are prelubricated. For extended bearing life, relubricate at least once every two years with a lithium base grease, such as Alvania 3 (Shell Oil), Chevron BRB2 (Standard Oil) or Regal AFB2 (Texas Oil). Use a hand grease gun for relubrication. Add only enough grease to purge through the bearings so that

UNIT	DRAFT GAUGE READING (DRY EVAPORATOR)			
	AIR VOLUME		READING	
	CFM	m ³ /hr	In. Water	mm Water
CHA8-953	2625	4460	.04 — .06	1.02 — 1.52
	3000	5100	.06 — .08	1.52 — 2.03
	3375	5735	.08 — .10	2.03 — 2.54
	3750	6370	.10 — .12	2.54 — 3.05
CHA8-1353	3850	6540	.25 — .27	6.35 — 6.86
	4400	7475	.20 — .31	5.08 — 7.87
	4950	8410	.33 — .35	8.38 — 8.89
	5500	9345	.37 — .39	9.40 — 9.91
CHA8-1853	5250	8920	.17 — .18	4.32 — 4.57
	6000	10 195	.19 — .20	4.83 — 5.08
	6750	11 470	.22 — .24	5.59 — 6.10
	7500	12 745	.26 — .28	6.60 — 7.11
CHA8-2753	7700	13 085	.24 — .26	6.10 — 6.60
	8800	14 950	.28 — .29	7.11 — 7.37
	9900	16 820	.31 — .33	7.87 — 8.38

NOTE—These readings are not total resistance readings, but pressure drop readings across the coil.

a bead of grease appears at the seal lip contacts. Refer to Figure 9.

- 2 - *Evaporator Blower Motor Bearings* - Bearings are prelubricated. For extended bearing life, relubricate at least once every two years with a lithium base grease, such as Westinghouse 53701RW, Chevron BRB2 (Standard Oil) or Andok 260 (Exxon Oil). To relubricate, replace top plugs with standard grease fittings. Remove lower outlet plugs and add grease with a hand gun until new grease appears at bottom outlets. Run motor for a short time before replacing bottom plugs. Refer to Figure 9.

- 3 - *Condenser Fan Motors* - Permanently sealed and lubricated.

B - Filters

Polyurethane filters are cleanable. Use following procedure:

- 1 - Remove filters from unit.
- 2 - To clean vacuum or wash with mild detergent in warm water. For increased efficiency, coat with water soluble oil (No. P-8-5069) available from your Lennox Dealer.

CAUTION - Some detergents have an adverse effect on filter media, causing it to lose its flexibility or become soft. It is recommended that dishwashing liquid be used. When cleaning filter, do not leave soaking in cleaner. Leave filter in cleaner only as long as it takes to clean it. Do not use enzyme detergents or pre-soakers. After filter is clean, rinse thoroughly before replacing unit.

- 3 - Replace filter with wire mesh on downstream side of air flow.

VI - SCHEMATIC WIRING DIAGRAM OPERATING SEQUENCE

Figures 10 and 11 illustrate typical CHA8 cooling and heating sequences of operation.

TYPICAL CHA8 COOLING SEQUENCE OF OPERATION (CHA8-2753-3F SHOWN)

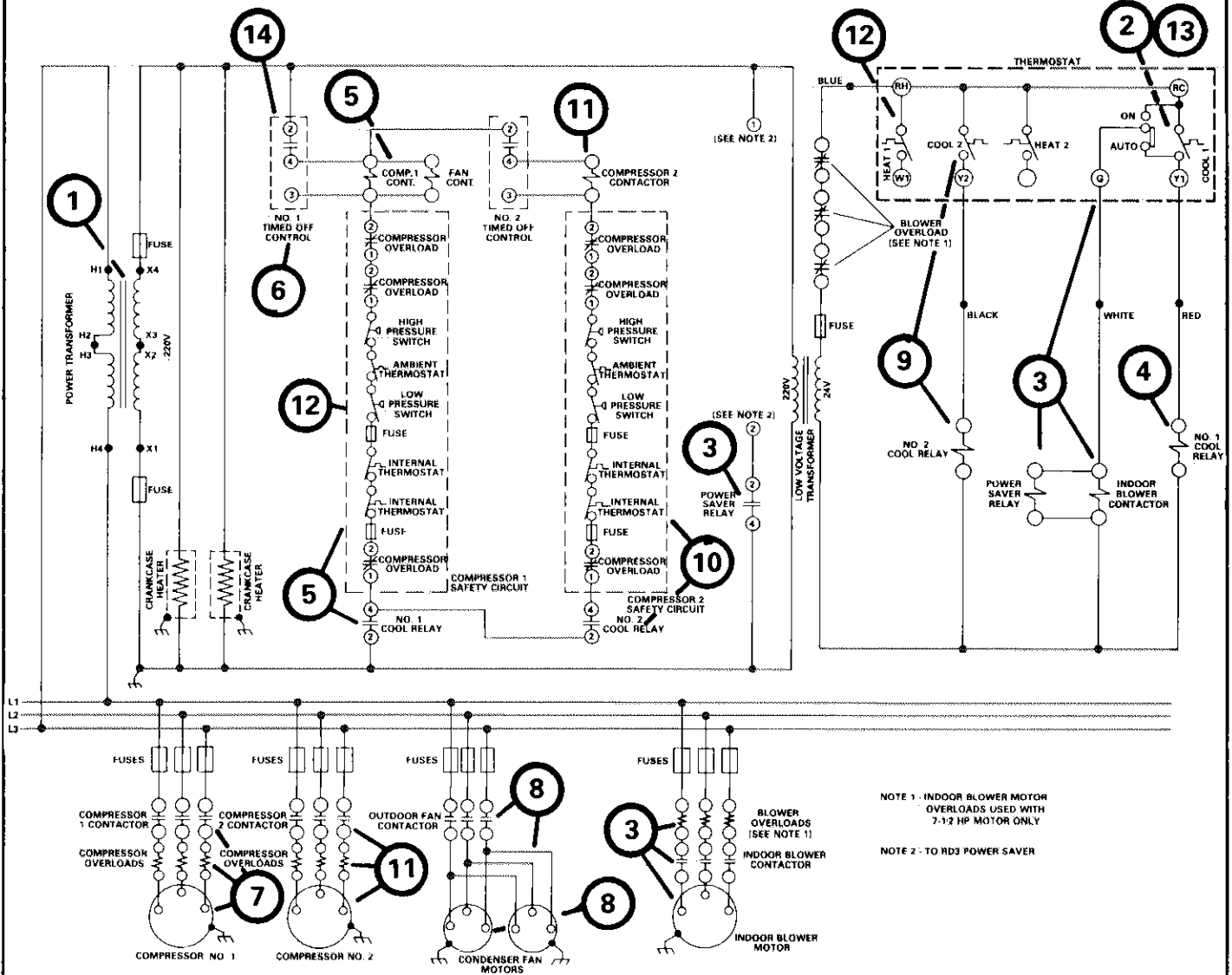

1 - On CHA8-953/1353 "G" & "J" and CHA8-1853/2753 "F" & "H" voltage units, the power transformer is energized continuously. It provides 220 volts for compressor safety circuit and on 953/1353 units it also provides 220 volts for condenser fan motors.

2 - On the initial cooling demand, the first stage cooling bulb makes at thermostat.
 3 - If the thermostat fan switch is set on "Auto", the Indoor Blower Contactor and Power Saver Relays are energized. The contactor energizes its N.O. contacts to power the indoor blower motor. The Power Saver Relay closes its N.O. contacts to initiate power saver operation.

NOTE - On CHA8-1853/2753-L units, the blower contactor activates power saver operation.

4 - As the first stage cooling bulb makes, it also energizes the No. 1 Cool Relay.
 5 - The No. 1 Cool Relay N.O. contacts close to complete a circuit to the No. 1 Timed Off Control through the L2 compressor protection:

- Compressor Overloads
- High Pressure Switch
- Ambient Thermostat
- Low Pressure Switch
- Fuses
- Internal Thermostat

6 - 20 seconds after the No. 1 Timed Off Control is powered it energizes the No. 1 compressor Contactor and Outdoor Fan Contactor (where used).

7 - The No. 1 Compressor Contactor closes its N.O. contacts to power No. 1 Compressor. On CHA8-953/1353 "Y" voltage units the condenser fan motors are also energized.

8 - On all units except the CHA8-953/1353 "Y" units, the Outdoor Fan Contactor closes its N.O. contacts to power the condenser fan motors.

CHA8-1853/2753 UNITS ONLY

9 - On a further cooling demand, the second stage cooling bulb makes to energize No. 2 Cool Relay.

10 - No. 2 Cool Relay closes its N.O. contacts to complete a circuit to the No. 2 Timed Off Control through the No. 1 Cool Relay contacts and the L2 compressor protection.

11 - 20 seconds after the No. 2 Timed Off Control is powered, it energizes the No. 2 Compressor Contactor. The contactor powers No. 2 compressor.

12 - If a safety control opens in No. 1 compressor, both compressors and condenser fan motors will de-energize.

13 - As the cooling demand is satisfied, the thermostat cycles off Compressor 2 and then Compressor 1.

14 - If the original cycle was less than 5 minutes, the timed off control will wait the remaining time plus 20 seconds on the next demand.

FIGURE 10

**TYPICAL CHA8/ECH8 HEATING SEQUENCE OF OPERATION
(CHA8-1853-3L SHOWN WITH ECH8-275-1923-2L)**

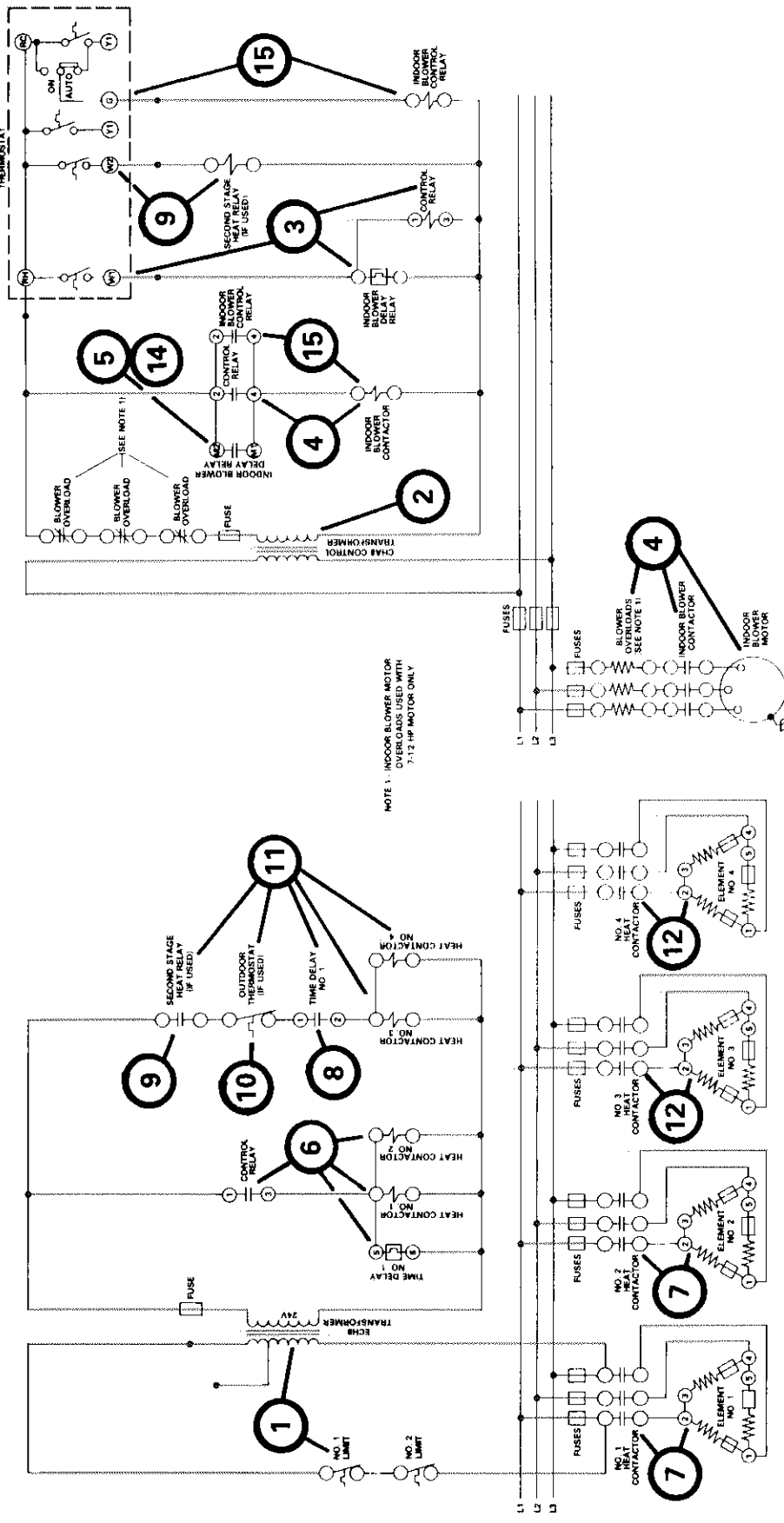

FIGURE 11

- 1 - The Electric Heat Transformer is powered through the limit controls.
- 2 - The thermostat circuit is powered by the CHA8 Control Transformer.
- 3 - On a heating demand the first stage heating bulb makes to energize the Control Relay and the Indoor Blower Delay Relay.
- 4 - The N.O. Control Relay No. 2 contacts close. This energizes the Indoor Blower Contactor and consequently the Indoor Blower Motor.
- Note - With the Indoor Blower Contactor energized, the power saver (if used) will be held at minimum position. (on CHA8-1853/2753-L voltage units.)*
- 5 - The Indoor Blower Delay Relay closes its contacts.
- 6 - The N.O. Control Relay No. 1 contacts also close. This energizes the No. 1 Time Delay, No. 1 Heat Contactor and No. 2 Heat Contactor.
- 7 - No. 1 & No. 2 Heat Contactors close their contacts to power elements 1 & 2. Each element is protected by fuses.
- 8 - The No. 1 Time Delay closes its contacts in approximately 30 seconds. This prevents all the elements from being energized simultaneously on a sudden full heating demand.