

**installation  
operation  
and  
maintenance  
instructions**

# **CHA15 SERIES UNITS**

**COOLING UNITS**  
502,131M  
/86  
supersedes 502,009M

## TABLE OF CONTENTS

Unit Dimensions.....	Page 1
Check List .....	Page 1
Requirements, Application, Installation .....	Page 2
Wiring Diagrams .....	Page 4
Start-Up, Unit Processing .....	Page 5
Adjustments, Maintenance .....	Page 6

## UNIT DIMENSIONS

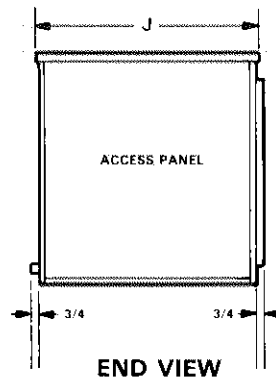
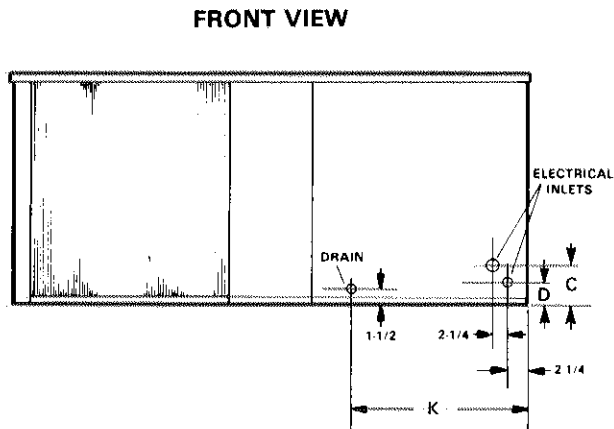
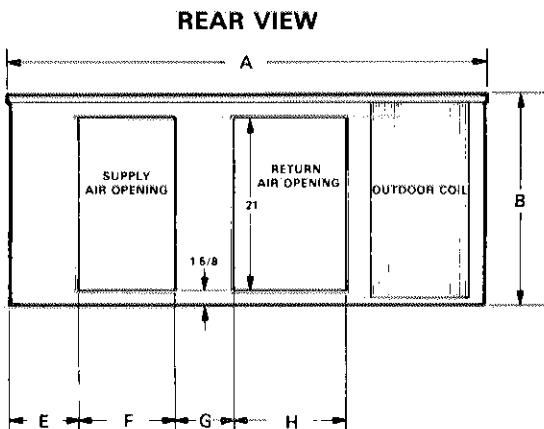

Model Number	A	B	C	D	E	F	G	H	J	K
CHA15-261/310	57-1/4 in. (1454 mm)	25-1/4 in. (641 mm)	2-5/16 in. (59 mm)	1-5/8 in. (41 mm)	8-1/8 in. (206 mm)	11-1/2 in. (292 mm)	6-15/16 in. (176 mm)	13-7/16 in. (341 mm)	24 in. (610 mm)	19-1/2 in. (495 mm)
CHA15-410/460	60-1/4 in. (1530 mm)	28-1/8 in. (714 mm)	2-9/16 in. (65 mm)	1-7/8 in. (48 mm)	8-3/4 in. (222 mm)	13-11/16 in. (348 mm)	4-13/16 in. (122 mm)	13-5/16 in. (338 mm)	30-3/4 in. (781 mm)	21-3/16 in. (538 mm)
CHA15-510/650	70 in. (1778 mm)	34-5/8 in. (880 mm)	3-1/4 in. (83 mm)	2-9/16 in. (65 mm)	7-3/4 in. (197 mm)	15-3/8 in. (391 mm)	5-3/16 in. (132 mm)	17-5/16 in. (440 mm)	37 in. (940 mm)	22-1/16 in. (560 mm)

## START-UP AND PERFORMANCE CHECK LIST

Job Name \_\_\_\_\_ Job No. \_\_\_\_\_ Date \_\_\_\_\_  
 Job Location \_\_\_\_\_ City \_\_\_\_\_ State \_\_\_\_\_  
 Installer \_\_\_\_\_ City \_\_\_\_\_ State \_\_\_\_\_  
 Unit Model No. \_\_\_\_\_ Serial No. \_\_\_\_\_ Serviceman \_\_\_\_\_

### ELECTRICAL

Unit Rating Plate Voltage \_\_\_\_\_  
 Minimum Circuit Ampacity \_\_\_\_\_  
 Maximum Fuse Size \_\_\_\_\_  
 Wire Connections Tight   
 Supply Voltage (Unit Off) 1&2 \_\_\_\_\_ 1&3 \_\_\_\_\_ 2&3 \_\_\_\_\_

### INDOOR BLOWER

Proper Blower Rotation  Filters Clean and Secure   
 Motor Amps: \_\_\_\_\_ Static Pressure (w.c.) \_\_\_\_\_

### COOLING SECTION

Refrigerant Lines Secure  Refrigerant Charge O.K.   
 Compressor Operating Voltage \_\_\_\_\_  
 Amps: Supply \_\_\_\_\_ Compressor \_\_\_\_\_  
 Condenser Fan Motor \_\_\_\_\_  
 Condenser Entering Air Temperature \_\_\_\_\_  
 Discharge Pressure \_\_\_\_\_ Suction Pressure \_\_\_\_\_  
 S.P. Drop over Evaporator (Dry) \_\_\_\_\_

### THERMOSTAT

Calibrated  Properly Set  Level

# REQUIREMENTS — APPLICATION — INSTALLATION

## I - SHIPPING AND PACKING LIST

Package 1 of 1 contains:

1 - Assembled unit

## II - SHIPPING DAMAGE

Check unit for shipping damage. Receiver should contact last carrier immediately if any damage is found.

## III - CODE REQUIREMENTS

Installation of Lennox air conditioners must conform with standards in National Fire Protection Association (NFPA) "Standard for Installation of Air Conditioning and Ventilating Systems NFPA No. 90A," "Standard for Installation of Residence Type Warm Air Heating and Air Conditioning Systems NFPA No. 90B," Canadian Electrical Code — Part 1 and applicable C.S.A. requirements, manufacturer's installation instructions and local municipal building codes. Unit is approved for clearance to combustible materials as listed on unit rating plate. Accessibility and service clearances must take precedence over fire protection clearances.

## IV - SERVICE CLEARANCES

Refer to figure 1. Service clearances for CHA15 series units are as follows:

Compressor compartment access — 36 inches (914 mm)

Blower compartment access — 36 inches (914 mm)

Outdoor coil end — 36 inches (914 mm)

Duct side — 12 inch (305 mm) minimum

Top clearance — 60 inches (1524 mm)

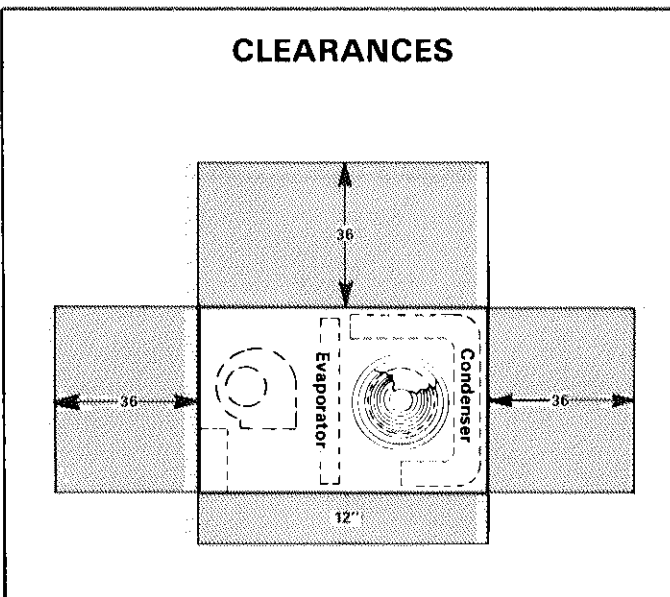

FIGURE 1

## V - SETTING THE UNIT

### A - Mounting on Lennox RMF15 Frame

Refer to instructions provided with roof mounting frame for installation specifics. Refer to additional optional equipment instruc-

tions if applicable. Complete necessary preparation before setting unit.

### B - Mounting on Field-Fabricated Supports

Many types of supports may be used for unit mounting. The following are important items to keep in mind when building supports:

- 1 - An enclosed support is not required since unit base is fully enclosed.
- 2 - Support must be square and level.
- 3 - Support must be high enough to prevent moisture from entering unit.
- 4 - Either wooden or metal supports are acceptable for mounting. After support has been installed, flashed and sealed, hoist unit to roof and lower onto supports.

### C - Slab Mounting

- 1 - Top of slab must be at least 4 inches (101 mm) above finished grade and located where water will not collect around unit. Slab must be level.
- 2 - Align unit opening in wall and set unit on slab.

## VI - DUCT CONNECTIONS

### A - Roof-Mounted Units

- 1 - Cut correct size openings (supply and return) in roof.
- 2 - Field fabricate curbing around opening.
- 3 - Insert correctly sized ducts through roof opening and secure to unit with sheet metal screws.
- 4 - Caulk around duct connections at unit.
- 5 - Flash and seal weathertight where ducts come through roof.

### B - Slab Mounted Units

- 1 - Make connections to supply and return air openings in unit with insulated duct. Secure with sheet metal screws.
- 2 - Caulk and seal weathertight around duct connections, both at the unit and where duct enters building.

## VII - CONDENSATE DRAIN PIPING

The following practices are recommended to ensure condensate removal. Before installation, check local codes concerning condensate removal. Refer to figure 2 for typical condensate piping.

- 1 - Drain piping should not be smaller than drain connection at coil.
- 2 - A trap in the drain line is recommended when drain is on the negative side of system blower. This will allow water to escape from the drain pan. It is also advisable to trap the line when drain is on the positive side of system blower. This will prevent conditioned air from escaping through the drain line.
- 3 - The trap must be deep enough to offset the difference in static pressure between drain pan and atmosphere. Generally 2 inches (51 mm) minimum is satisfactory for medium static applications.
- 4 - Horizontal runs must be pitched 1 inch (25 mm) per 10 feet (3048 mm) of drain line to offset line friction.
- 5 - An open vent in drain line will sometimes be required due to line length, friction and static pressure.
- 6 - Drains should be constructed in a manner to facilitate future cleaning.

7 - On applications where a drain line is not required, install a 90° elbow on drain connections to direct condensate downward.

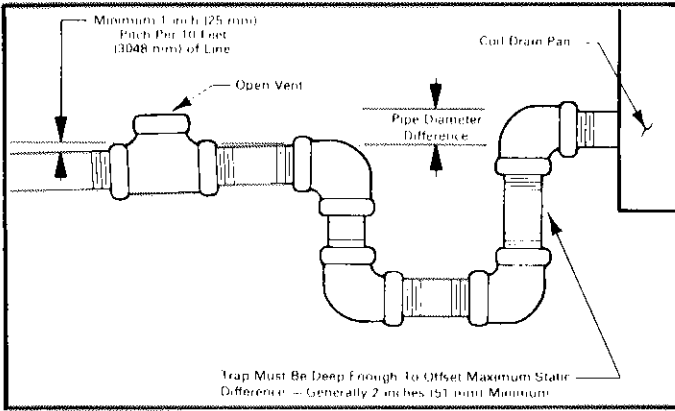

**FIGURE 2**

**VIII - ELECTRICAL CONNECTIONS**

Wiring must conform to National Electrical Code (NEC) and any local codes. Refer closely to unit wiring diagram or field wiring diagram in this instruction for wiring make-up.

Refer to unit rating plate for minimum circuit ampacity and maximum fuse size.

1 - Knockouts are provided in front of unit to facilitate conduit and control wiring entry. Refer to dimension drawing on page 1 for locations. Remove knockouts and insert proper conduit fitting for power wiring. Insert grommet provided in control wiring hole. Seal around control wiring to prevent air leakage.

If an ECB18 heater is being installed, an electrical conduit plate may be required. See Electrical Conduit Data table in ECB18 installation instructions to determine conduit plate requirements. To install conduit piping plate, remove the screws at the electrical inlet and secure the plate with the existing screws.

2 - Install thermostat (ordered separately) approximately 5 feet (1.5 m) from floor in a location where it will not be affected by sunlight, drafts or vibration.

3 - Complete wiring according to unit diagram or field wiring diagram in this instruction.

4 - Two high voltage terminal blocks are supplied with the unit: TB2 for field power connection to the unit and TB3 for field power connection to the optional ECB18 electric heat module. Two lugs are provided for connection to earth or supply ground.  
*NOTE - 460, 575 and 380/420V units do not include the TB3 field power terminal block. These units are equipped with a single ground lug.*

*NOTE - On 15, 20 and 25 Kw models, field power for electric heat section is connected directly to ECB18 circuit breakers. On 460, 575 and 380/420V models, field power for electric heat section is connected to ECB18 fuse block.*

**IX - INITIAL START-UP**

Before starting unit, remove any shipping blocks or banding. Refer to start-up and operation section for start-up procedures.

**X - UNIT AIR VOLUME**

Unit is equipped with direct drive, multi-speed indoor blower. See unit wiring diagram for factory setting.

UNIT	MINIMUM BLOWER SPEED			
	CHA15-260/310	CHA15-410/460	CHA15-510/650 (208/240V)	CHA15-510/650 (460/575V)
CHA15 WITH ELECTRIC HEAT	LOW	LOW	MED-LOW	LOW

# FIELD WIRING

NOTE - On units with electric heat, refer to electric heat installation instructions for field wiring.

## SINGLE-PHASE UNITS

CHA15-261/461

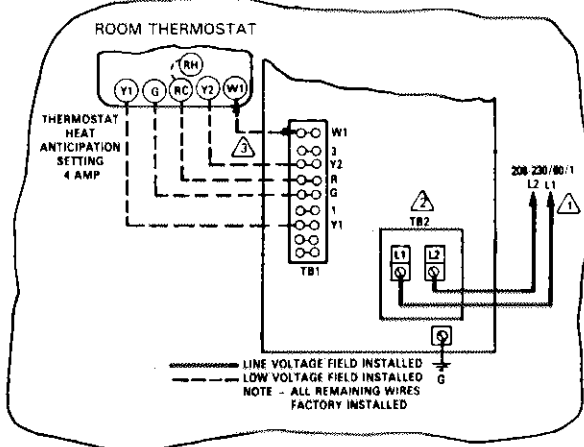

- 1 Refer to unit rating plate for minimum circuit ampacity and maximum fuse size.
- 2 Connections made to TB2 are for A-C & H.P. functions only on units with and without electric heat.
- 3 Used with electric heat only.

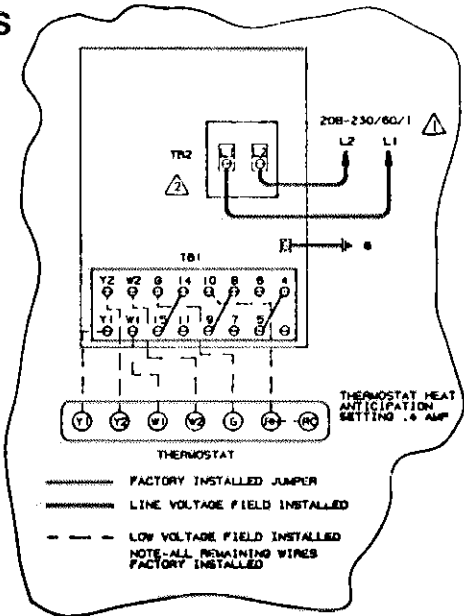

CHA15-511/651

## THREE-PHASE UNITS

CHA15-313/463

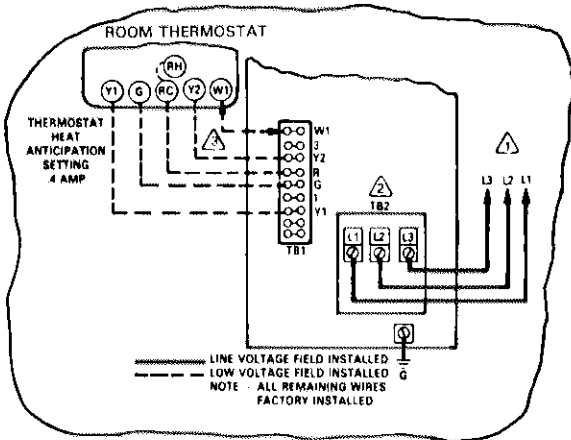

- 1 Refer to unit rating plate for minimum circuit ampacity and maximum fuse size.
- 2 Connections made to TB2 are for A-C & H.P. functions only on units with and without electric heat.
- 3 Used with electric heat only.

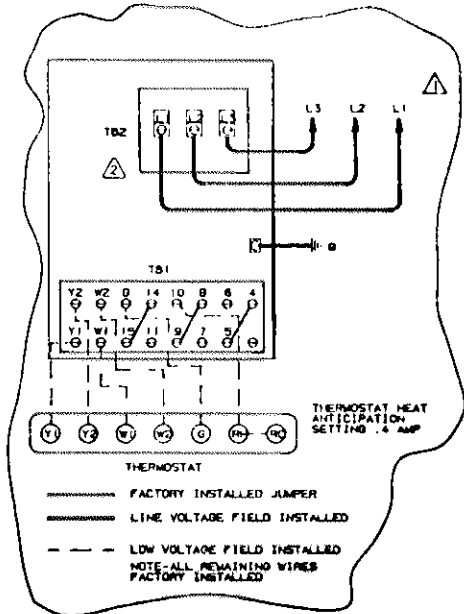

CHA15-513/653

# START-UP — CHARGING — MAINTENANCE

## I - UNIT START-UP AND OPERATION

### A - Heating (Optional ECB18 electric heat)

Place thermostat system switch in "Heat" position and fan switch in either "On" or "Auto" position. Close unit disconnect switch and set thermostat above room temperature. Electric heat and blower operation will cycle with room thermostat demand if fan switch is in "Auto" position.

### B - Cooling

- 1 - Place thermostat in "Cool" position and blower switch in "On" or "Auto" position. Set cooling adjustment level below room temperature. Close unit disconnect switch.
- 2 - Compressor and condenser fan will start and cycle on demand from thermostat. Blower will cycle according to position of blower switch on thermostat.

## II - UNIT PROCESSING

### A - Attaching Gauge Manifold

- 1 - Attach gauge manifold high pressure line to gauge port on compressor discharge line (261/310 units only). Refer to figure 3. *NOTE - High pressure line is attached to gauge port on thermometer well on CHA15-410/650 units.*
- 2 - Attach gauge manifold low pressure line to suction service port.

### B - Charging/Checking Charge

If system is completely void of refrigerant, the recommended and most accurate method of charging is to weigh refrigerant into unit according to amount shown on unit rating plate. Refer to Lennox Unit Information Service Manual. If weighing facilities are not available or if unit is low on charge, use the following procedure:

- 1 - Connect gauge manifold as shown in figure 3. Connect an upright R-22 drum to center port of gauge manifold.
- 2 - Open drum valve and charge a quantity of refrigerant gas into system through compressor suction port; close refrigerant drum

valve. Allow unit to run a few minutes to stabilize operating pressures.

- 3 - Follow instructions given on unit access panel for proper system charging.
- 4 - When system is operating properly, disconnect gauge manifold. Replace all gauge port caps and tighten. Set thermostat to desired setting.

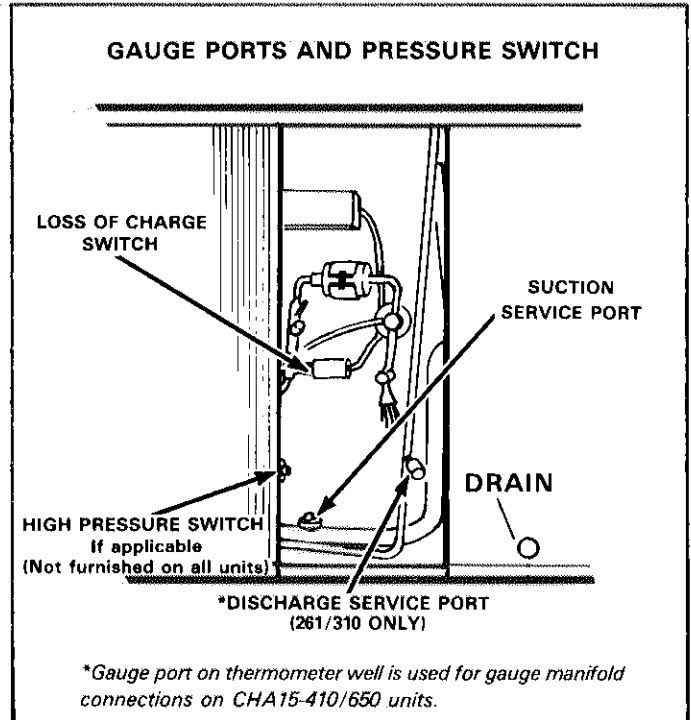

FIGURE 3



### III - MAINTENANCE

At the beginning of each cooling and heating season, system should be checked as follows:

#### A - Condenser and Evaporator Coil

- 1 - Check and clean coils if necessary.
- 2 - Check connecting lines and coils for evidence of leaks.  
*NOTE - If unit is not cooling properly, check refrigerant charge. Refer to section II, Unit Processing.*

#### B - Filter

Filter is installed external to the CHA15 unit. Filter is required and must be provided by installer. Filter should be checked periodically and replaced if necessary.

#### C - Lubrication

- 1 - Motors without Oiling Ports-Prelubricated and sealed. No further lubrication required.
- 2 - Motors with Oiling Ports-Prelubricated for an extended period of operation. For extended bearing life, relubricate with a few drops of SAE No. 10 non-detergent oil once every two years. It may be necessary to remove blower assembly for access to oiling ports.

#### D - Electrical

- 1 - Check all wiring for loose connections.
- 2 - Check for correct voltage at unit (unit operating).

- 3 - Check amp-draw on both outdoor fan motor and blower motor.  
Fan Motor Rating Plate \_\_\_\_\_ Actual \_\_\_\_\_  
Blower Motor Rating Plate \_\_\_\_\_ Actual \_\_\_\_\_

#### E - Loss of Charge Switch

Loss of charge switch is located in liquid line as shown in figure 3. Loss of charge switch opens at  $25 \pm 5$  psig and automatically resets at  $55 \pm 5$  psig.

#### F - Compressor Oil Charge

Refer to Lennox Unit Information Service Manual for correct procedure to check and add compressor oil.

#### G - Crankcase Heater

Compressor is provided with crankcase heater which must always be energized to prevent compressor damage due to refrigerant migration.

*IMPORTANT - Failure to heed this warning will void the warranty.*

#### H - High Pressure Switch

Some models may be equipped with a high pressure switch as shown in figure 3. High pressure switch opens at  $410 \pm 10$  psig and is manually reset.