



# Installation, operating and maintenance **FLEXY II**



- Providing indoor climate comfort



# INSTALLATION OPERATION MAINTENANCE MANUAL

Ref. FLEXYII\_IOM/0308-E

The present manual applies to the following ROOFTOP versions:

FCM 85 - FCM 100 - FCM 120 - FCM 150 - FCM 170 - FCM 200 - FCM 230

FHM 85 - FHM 100 - FHM 120 - FHM 150 - FHM 170 - FHM 200 - FHM 230

FDM 85 - FDM 100 - FDM 120 - FDM 150 - FDM 170 - FDM 200 - FDM 230

FGM 85 - FGM 100 - FGM 120 - FGM 150 - FGM 170 - FGM 200 - FGM 230

FXK 25 - FXK 30 - FXK 35 - FXK 40 - FXK 55 - FXK 70 - FXK 85 - FXK 100 - FXK 110 - FXK 150 - FXK 170

## NOTES FOR UNIT FITTED WITH GAS BURNER:

THE UNIT MUST BE INSTALLED IN ACCORDANCE WITH LOCAL SAFETY CODES AND REGULATIONS AND CAN ONLY BE USED IN WELL VENTILATED AREA.  
PLEASE READ CAREFULLY THE MANUFACTURER'S INSTRUCTIONS BEFORE STARTING THIS UNIT.

Switchgear must be installed on each unit in accordance with the Machine Directive and the standard NF EN 60204.

THIS MANUAL IS ONLY VALID FOR UNITS DISPLAYING THE FOLLOWING CODES: **GB IR GR DA NO FI IS**

In case these symbols are not displayed on the unit, please refer to the technical documentation which will eventually detail any modifications required to the installation of the unit in a particular country.

LENNOX have been providing environmental solutions since 1895, our range of Baltic™ rooftop continues to meet the standards that have made LENNOX a household name. Flexible design solutions to meet YOUR needs and uncompromising attention to detail. Engineered to last, simple to maintain and Quality that becomes a standard. Further Information on [www.lennox europe.com](http://www.lennox europe.com).

All the technical and technological information contained in this manual, including any drawing and technical descriptions provided by us, remain the property of Lennox and must not be used (except in operation of this product), reproduced, issued to or made available to third parts without the prior written agreement of Lennox.

The technical informations and specifications contained in this manual are for reference only. The manufacturer reserves the right to modify these without warning and without obligation to modify equipment already sold.

<b><u>COMMISSIONING SHEET</u></b> .....	6
<b><u>INSTALLATION</u></b>	
Transport - Handling.....	10
Dimensions and weights.....	12
Lifting the units.....	14
Preliminary checks.....	15
Minimum clearance around the unit.....	16
Installation on roof mounting frame .....	17
Curbing and flashing .....	18
Duct connections.....	19
Non-adjustable non-assembled roof curb installation .....	20
Non-adjustable non-assembled roof curb installation instructions.....	21
Adjustable roof curb .....	22
Non-adjustable Non-assembled roof curb .....	23
Multidirectional roof curb .....	24
Return roof curb .....	25
Return horizontal roof curb .....	26
Transition roof curb .....	27
Energy Recovery.....	28
Economiser and extraction .....	29
<b><u>COMMISSIONING</u></b>	
Before connecting the power .....	30
CLIMATIC.....	31
Powering the unit .....	31
Run test.....	32
<b><u>VENTILATION</u></b>	
Belt tension .....	33
Mounting and adjusting pulleys.....	34
Airflow balancing.....	35
Filters .....	43
Air sock control.....	44
UV Light.....	45
<b><u>HEATING OPTIONS</u></b>	
Hot water coils .....	46
Electric heater .....	48
Gas burners.....	49
Modulating gas burners .....	60

**ELECTRICAL DATA: WIRING DIAGRAMS**

Diagram reference legend .....69

Main current diagram TRI/400V/50Hz + T.....70

CLIMATIC 50 controller.....72

CLIMATIC 50 input.....73

CLIMATIC 50 output.....74

DAD smoke detector.....75

General customer connection (TCB .....76

General customer connection with Advanced Control Pack (ADC) .....77

Gas burner 60 kW and hot water coil.....78

Gas burner 120 kW .....79

Gas burner 180/240 kW.....80

Electric heater .....81

General customer connection diagram .....82

Electrical data control variables.....83

**REFRIGERATION CIRCUIT**

R410A .....84

Advanced scroll temperature protection (ASTP) .....85

Principle sketches .....86

**HOT WATER COIL**.....90

**MAINTENANCE DIAGNOSTIC**.....91

**MAINTENANCE PLAN**.....94

**WARRANTY**.....97

**CERTIFICATES**.....98

All FLEXY II Units are compliant with the PED directive 97-23/CE  
The following note must be followed carefully

**All work on the unit must be carried out by a qualified and authorised employee.**

Non-compliance with the following instructions may result in injury or serious accidents.

**Work on the unit:**

- The unit shall be isolated from the electrical supply by disconnection and locking using the main isolating switch.
- Workers shall wear the appropriate personal protective equipment (helmet, gloves, glasses, etc.).

**Work on the electrical system:**

- Work on electric components shall be performed with the power off by employees having valid electrical qualification and authorisation.

**Work on the refrigerating circuit(s):**

- Monitoring of the pressures, draining and filling of the system under pressure shall be carried out using connections provided for this purpose and suitable equipment.
- To prevent the risk of explosion due to spraying of coolant and oil, the **relevant circuit shall be drained and at zero pressure** before any disassembly or unbrazing of the refrigerating parts takes place.
- There is a residual risk of pressure build-up by degassing the oil or by heating the exchangers after the circuit has been drained. Zero pressure shall be maintained by venting the drain connection to the atmosphere on the low pressure side.
- The brazing shall be carried out by a qualified brazier. The brazing shall comply with standard NF EN1044 (minimum 30% silver).

**Replacing components:**

- In order to maintain CE marking compliance, replacement of components shall be carried out using spare parts, or using parts approved by Lennox.
- Only the coolant shown on the manufacturer's nameplate shall be used, to the exclusion of all other products (mix of coolants, hydrocarbons, etc.).

**CAUTION:**

**In the event of fire, refrigerating circuits can cause an explosion and spray coolant gas and oil.**

**TRANSPORT – HANDLING:**

- Never lift the unit without forklift protections
- Remove the forklift protection before installation
- An approach ramp must be installed if the unit's installation requirements tell that it's necessary to reach the main switch. This recommendation is valid for installations in general and in particular for return and curbs. It's also valid to reach other parts of the unit: filters, refrigerant circuit, etc...
- It's advised to fix curbs and roofcurbs to the unit
- Whatever the supply configuration is, respect a minimal duct's length of 2m before any elbow or any duct's section change.

**COMMISSIONING:**

- It must only be carried out by trained refrigeration engineers.
- Don't forget to open the insulation valve on the liquid line before starting the unit

**FILTERS:**

- Do the filters fire classification's choice according to local regulations.

**FANSTART:**

- Any adjustment has to be done power stopped.

**GAS:**

- Any work on gas module must be carried out by qualified personnel
- A unit with gas module must be installed in accordance with local safety codes and regulations and can only be used in planned installation conditions for outdoor.
- Before commissioning this type of unit, it's mandatory to ensure that the gas distribution system is compatible with the adjustment and settings of the unit.

UV LIGHT:

- **The UV lamp emits shortwave UV-C ultraviolet radiation which is harmful to skin and eyes**
- **It can cause serious skin burns and eye inflammation within ONE SECOND of exposure**
- Do not enter the machine while UV are switched on
- Make sure the UV light circuit breaker is OFF when opening the return air section door and the supply air section doors
- The following logo will appear to inform about the UV-C radiation risk



<b>Site details</b>	<b>Controller</b> .....
<b>Site</b> .....	<b>Model</b> .....
<b>Unit Ref</b> .....	<b>Serial No</b> .....
<b>Installer</b> .....	<b>Refrigerant</b> .....

**(1) ROOF INSTALLATION**

Sufficient Access OK Yes <input type="checkbox"/> No <input type="checkbox"/>	Condensate drain fitted Yes <input type="checkbox"/> No <input type="checkbox"/>	Roofcurb OK <input type="checkbox"/> Not OK <input type="checkbox"/>
--	---	---

**(2) CONNECTIONS CHECK**

Phase check Yes <input type="checkbox"/> No <input type="checkbox"/>	Voltage Phases between	1 / 2 .....	2 / 3 .....	1 / 3 .....
---	------------------------	----------------	----------------	----------------

**(3) CLIMATIC CONFIGURATION CHECK**

CLIMATIC 50 Configured according to the Options and Specifications: Yes <input type="checkbox"/> No <input type="checkbox"/>
---

**(4) SUPPLY BLOWER SECTION**

		N°1	N°2
Type :		.....	.....
Power displayed on plate:	KW	.....	.....
Voltage displayed on plate:	V	.....	.....
Current displayed on plate:	A	.....	.....
Fan Type :		Forward <input type="checkbox"/>	Forward <input type="checkbox"/>
		Backward <input type="checkbox"/>	Backward <input type="checkbox"/>
Displayed Belt Length :	mm	.....	.....
Tension Checked:		Yes <input type="checkbox"/> No <input type="checkbox"/>	Yes <input type="checkbox"/> No <input type="checkbox"/>
Alignment Checked :		Yes <input type="checkbox"/> No <input type="checkbox"/>	Yes <input type="checkbox"/> No <input type="checkbox"/>
Motor Pulley Diameter: D <sub>M</sub>	mm	.....	.....
Fan Pulley Diameter: D <sub>P</sub>	mm	.....	.....
Fan Speed = Motor rpm x D <sub>M</sub> / D <sub>P</sub>	rpm	.....	.....
Averaged Measured Amps :	A	.....	.....
Shaft Mechanical Power (Refer to airflow balancing)	W	.....	.....
Operating point checked :		Yes <input type="checkbox"/> No <input type="checkbox"/>	Yes <input type="checkbox"/> No <input type="checkbox"/>
Estimated Airflow	m <sup>3</sup> /h	.....	.....

**(5) AIRFLOW PRESS. SENSOR CHECK**

Measured pressure drop..... mbar	Set Points Adjusted: Yes <input type="checkbox"/> No <input type="checkbox"/> If Yes enter new values: <b>3410:</b> ..... <b>3411:</b> ..... <b>3412:</b> .....
----------------------------------	---

**(6) EXTERNAL SENSOR CHECKS**

Check electrical connections : Yes <input type="checkbox"/> No <input type="checkbox"/>	Check and record temp. in menu <b>2110</b> Yes <input type="checkbox"/> Non <input type="checkbox"/>	
	100% Fresh Air	100% return Air
Supply Temperature	.....°C	.....°C
Return Temperature	.....°C	.....°C
Outdoor Temperature	.....°C	.....°C

**(7) MIXING AIR DAMPERS CHECKS**

Dampers open & close freely OK Yes <input type="checkbox"/> No <input type="checkbox"/>	% Minimum FA: .....%	Power exhaust checked Yes <input type="checkbox"/> No <input type="checkbox"/>	Enthalpy sensor(s) checked Yes <input type="checkbox"/> No <input type="checkbox"/>
---	-------------------------	---	--

**(8) REFRIGERATION SECTION**

Outdoor Fan Motor Current:				Check Rotation		Compressor Voltage	
Motor 1 / Moteur 1	L1 .....A	L2 .....A	L3 .....A	Yes <input type="checkbox"/>	No <input type="checkbox"/>		
Motor 2 / Moteur 2	L1 .....A	L2 .....A	L3 .....A	Yes <input type="checkbox"/>	No <input type="checkbox"/>	Comp1: ..... V	
Motor 3 / Moteur 3	L1 .....A	L2 .....A	L3 .....A	Yes <input type="checkbox"/>	No <input type="checkbox"/>	Comp2: ..... V	
Motor 4 / Moteur 4	L1 .....A	L2 .....A	L3 .....A	Yes <input type="checkbox"/>	No <input type="checkbox"/>	Comp3: ..... V	
Motor 5 / Moteur 5	L1 .....A	L2 .....A	L3 .....A	Yes <input type="checkbox"/>	No <input type="checkbox"/>	Comp4: ..... V	
Motor 6 / Moteur 6	L1 .....A	L2 .....A	L3 .....A	Yes <input type="checkbox"/>	No <input type="checkbox"/>	Comp4: ..... V	
Compressor Amps COOLING				Pressures & Temperatures			
	Phase 1	Phase 2	Phase 3	Temperatures		Pressures	
				Suction	Discharge	LP/ BP	HP / HP
Comp 1	..... A	..... A	..... A	..... °C	..... °C	..... Bar	..... Bar
Comp 2	..... A	..... A	..... A	..... °C	..... °C	..... Bar	..... Bar
Comp 3	..... A	..... A	..... A	..... °C	..... °C	..... Bar	..... Bar
Comp 4	..... A	..... A	..... A	..... °C	..... °C	..... Bar	..... Bar
Check Reversing valves :				Valve1: Yes <input type="checkbox"/> No <input type="checkbox"/>	Valve3: Yes <input type="checkbox"/> No <input type="checkbox"/>	Valve2: Yes <input type="checkbox"/> No <input type="checkbox"/>	Valve4: Yes <input type="checkbox"/> No <input type="checkbox"/>
Compressor Amps HEATING				Pressures & Temperatures			
	Phase 1	Phase 2	Phase 3	Temperatures		Pressures	
				Suction	Discharge	LP/ BP	HP / HP
Comp 1	..... A	..... A	..... A	..... °C	..... °C	..... Bar	..... Bar
Comp 2	..... A	..... A	..... A	..... °C	..... °C	..... Bar	..... Bar
Comp 3	..... A	..... A	..... A	..... °C	..... °C	..... Bar	..... Bar
Comp 4	..... A	..... A	..... A	..... °C	..... °C	..... Bar	..... Bar
HP cut out .....Bar				LP cut out ..... Bar			
Refrigerant charge				C1 : .....kg	C2 : .....kg	C3 : .....kg	C4 : .....kg

**(8)ELECTRIC HEATER SECTION**

Type : .....	Serial No.:.....				
AMPS 1 <sup>st</sup> stage (Baltic)			AMPS 2 <sup>nd</sup> stage (Baltic)		
1 .....	2 .....	3 .....	1 .....	2 .....	3 .....

**(9) HOT WATER COIL SECTION**

Check Three Way Valve Movement : Yes <input type="checkbox"/> No <input type="checkbox"/>
---

**(10) GAS HEATING SECTION**

Gas Burner N°1				Gas Burner N°2			
Size :	Valve type :			Size :	Valve type :		
.....	.....			.....	.....		
Pipe size:	Gas type : <b>G</b> .....			Pipe size	Gas type : <b>G</b> .....		
Line pressure :	Drop test Yes <input type="checkbox"/> No <input type="checkbox"/>			line pressure :	Drop test Yes <input type="checkbox"/> No <input type="checkbox"/>		
Check manifold pressure: High fire ..... Low fire .....				Check manifold pressure: High fire ..... Low fire .....			
Pressure cut out airflow press switch : .....mbar /Pa				Pressure cut out airflow press switch : .....mbar /Pa			
Motor amps :	Flue temp.	CO2 %:	CO ppm:	Motor Amps:	Flue temp.	CO2 %:	CO ppm:
.....A	..... °C	.....%	.....%	.....A	..... °C	.....%	.....%

**(11) REMOTE CONTROL BMS CHECK**

Type :	Sensor type	KP07 KP/17 checked: Yes <input type="checkbox"/> No <input type="checkbox"/>	Interconnect wiring checked: Yes <input type="checkbox"/> No <input type="checkbox"/>
--------	-------------	---	--



It is recommended that you fill the two tables below before transferring the zone settings to the Climatic 50 controller.

Refer to control section page 55 / Se référer à la section régulation page 55

**Time Zones / Zones Horaires**

Hour	0	1	2	3	4	5	6	7	8	9	10	11	12	13	14	15	16	17	18	19	20	21	22	23
Example	UNO							7h15	ZA			11h00	ZB		14h00	ZC			19h00	UNO				
Monday																								
Tuesday																								
Wednesday																								
Thursday																								
Friday																								
Saturday																								
Sunday																								

**Variables to adjust for each time zone / Consignes à renseigner pour chaque zone horaire**

	Start z.A		Start z.B		Start z.C		Start UNO	
	hour (3211)	min (3212)	hour (3213)	min (3214)	hour (3215)	min (3216)	hour (3217)	min (3218)
Monday								
Tuesday								
Wednesday								
Thursday								
Friday								
Saturday								
Sunday								

Description	Unit	Menu	Min	Max	Zone A	Zone B	Zone C	UNOC
Sp Room	°C	3311	8	35				
Mini.Air	%	3312	0	100				
Sp Dyna	°C	3321	0	99.9				
Sp Cool	°C	3322	8	35				
Sp Heat	°C	3323	8	35				
Swap Heater	On/Off	3324	~	~				
Activation	On/Off	3331	~	~				
Swap Heater	On/Off	3332	~	~				
Sp.Dehu	%	3341	0	100				
Sp.Humi	%	3342	0	100				
Fan On/Off	On/Off	3351	~	~				
Fan Dead	On/Off	3352	~	~				
F.Air	On/Off	3353	~	~				
CO2	On/Off	3354	~	~				
Comp.Cool.	On/Off	3355	~	~				
Comp.Heat.	On/Off	3356	~	~				
AuxHeat	On/Off	3357	~	~				
Humidif.	On/Off	3358	~	~				
Low Noise	On/Off	3359	~	~	N/A	N/A	N/A	



**DELIVERY CHECKS**

On receipt of a new equipment please check the following points. It is the customer’s responsibility to ensure that the products are in good working order:

- The exterior has not been damaged in any way.
- The lifting and handling equipment are suitable for the equipment and comply with the specifications of the handling instructions enclosed here-in.
- Accessories ordered for on site installation have been delivered and are in good working order.
- The equipment supplied corresponds to the order and matches the delivery note.

If the product is damaged, exact details must be confirmed in writing by registered post to the shipping company within 48 hours of delivery (working days). A copy of the letter must be addressed to Lennox and the supplier or distributor for information purposes. Failure to comply will invalidate any claim against the shipping company.

**RATING PLATE**

The rating plate provides a complete reference for the model and ensures that the unit corresponds to the model ordered. It states the electrical power consumption of the unit on start-up, its rated power and its supply voltage. The supply voltage must not deviate beyond +10/-15 %. The start-up power is the maximum value likely to be achieved for the specified operational voltage. The customer must have a suitable electrical supply. It is therefore important to check whether the supply voltage stated on the unit's rating plate is compatible with that of the mains electrical supply. The rating plate also states the year of manufacture as well as the type of refrigerant used and the required charge for each compressor circuit.

<b>LENNOX</b>		<b>CE</b>		Usage Climatisation	
		0 0 6 2		Usine Dijon	
TYPE		<b>FHM 120 N</b>		Z.I. LONGVIC	
UNIT TYPE				21600 LONGVIC	
				FRANCE	
N° SERIE		<b>250957_1 1/1</b>			
SERIAL NUMBER					
ALIMENTATION		400 V 3		ANNEE	
ELEC. SUPPLY		~ 50 Hz		YEAR	
				2006	
I. MAXI		I. DEMARR.		C. COMMANDE	
MAX AMP.		START UP AMP.		CONTROL CIR.	
86.8 A		193.7 A		24 V	
REFRIGERANT		R410A		Kg / CIRC	
FLUIDE Groupe 2		10.6		10.6	
		C 1		C 2	
		C 3		C 4	
Date d'épreuve		23/03/2006		Pression max (PS) déclenchement pressostat HP	
				Maximum working pressure (PS)	
				42.0 bar	
Temp maxi stockage		50 °C		Temp mini stockage	
Maximum storage temp				Minimum storage temp	
				-35 °C	

Fig. 1

**STORAGE**

When units are delivered on site they are not always required immediately and are sometimes put into storage. In the event of medium to long-term storage, we recommend the following procedures:

- Ensure that there is no water in the hydraulic systems.
- Keep the heat exchanger covers in position (AQUILUX cover).
- Keep protective plastic film in position.
- Ensure the electrical panels are closed.
- Keep all items and options supplied in a dry and clean place for future assembly before using the equipment.

**MAINTENANCE KEY**

On delivery we recommend that you keep the key which is attached to an eyebolt in a safe and accessible place. This allows you to open the panels for maintenance and installation work.

The locks are ¼ turn + then tighter (figure 2).



Figure 2

**CONDENSATE DRAINS**

The condensate drains are not assembled when delivered and are stored

in the electrical panel with their clamping collars.

To assemble them, insert them on the condensate tray outlets and use a screwdriver to tighten the collars (Figure 3).



Fig. 3

## MANDATORY HANDLING DEVICES

*Handling slings to guide the unit towards the roof curb*



*Vacuum lifting beam to position the unit*



**COMPLIANT**



**NON-COMPLIANT**

**DIMENSIONS AND WEIGHTS**

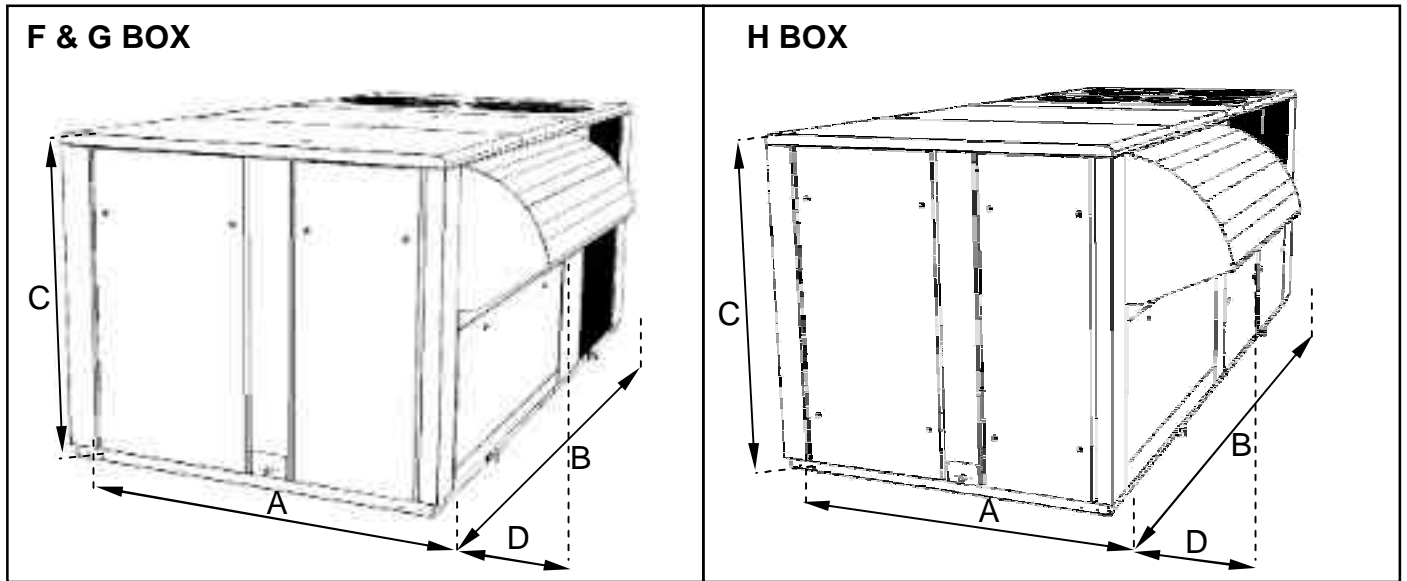

FLEXY2	FCM/FHM/FGM/FDM	85	100	120	150	170	200	230
<b>View (F, G, H box)</b>		F BOX	F BOX	F BOX	G BOX	G BOX	H BOX	H BOX
<b>A</b>	mm	2200	2200	2200	2200	2200	2200	2200
<b>B</b>	mm	3350	3350	3350	4380	4380	5533	5533
<b>C</b>	mm	1510	1510	1510	1834	1834	2134	2134
<b>D</b>	mm	360	360	360	450	450	615	615
<b>Weight of standard units FCM</b>								
Without economiser	kg	933.8	1008.8	1085.0	1367.0	1430.0	1650.0	1950.0
With economiser	kg	990.3	1065.3	1141.5	1442.0	1505.0	1751.7	2051.7
<b>Weight gas unit FGM</b>								
Standard heat Without economiser	kg	1040.8	1115.8	1192.0	1608.0	1671.0	1913.9	2213.9
Standard heat With economiser	kg	1097.3	1172.3	1248.5	1683.0	1746.0	2015.6	2315.6
High heat without economiser	kg	1110.8	1185.8	1262.0	1631.0	1694.0	1954.1	2254.1
High heat With economiser	kg	1167.3	1242.3	1318.5	1706.0	1769.0	2055.8	2355.8

**DIMENSIONS AND WEIGHTS**

	LENGTH	HEIGHT	WIDTH	HOOD		WEIGHT
	mm	mm	mm	Side	Fan	Standard
				mm	mm	kg
FXK025	4070	1635	1055	490	600	950
FXK030	4070	1635	1055	490	600	980
FXK035	4750	2255	1290	490	600	1400
FXK040	4750	2255	1290	490	600	1450
FXK055	4750	2255	1290	490	600	1600
FXK070	5050	2255	1725	890	600	1800
FXK085	5050	2255	1725	890	600	1900
FXK100	5050	2255	1725	890	600	2000
FXK110	5650	2255	2000	860	-	2620
FXK140	5650	2255	2000	860	-	2620
FXK170	5650	2255	2000	860	-	2650

### LIFTING THE UNIT

As shown on the picture below, a lifting frame is necessary.

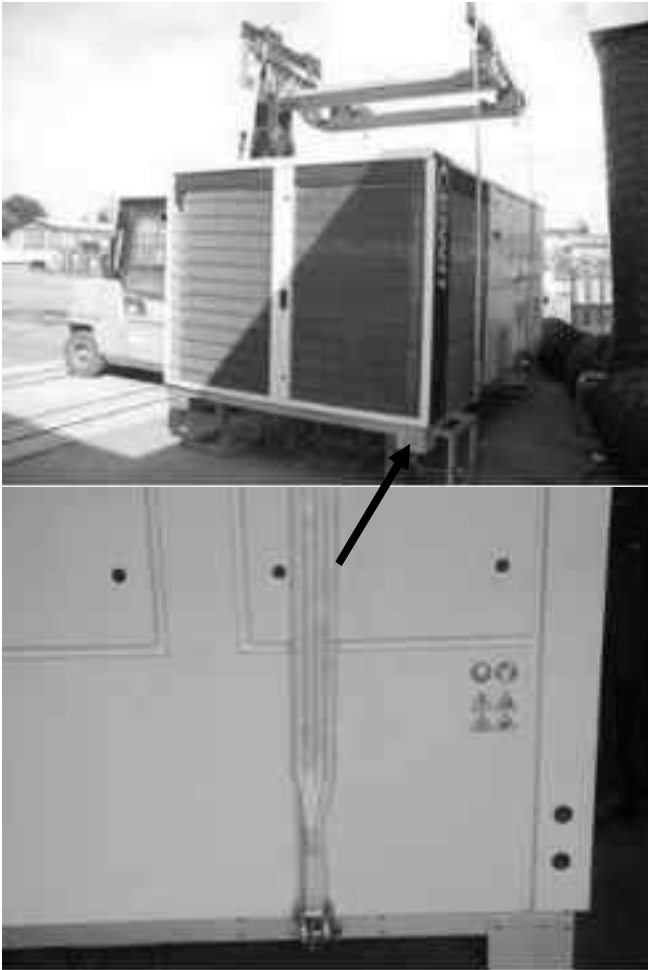

After lifting, withdraw angle's feet and lifting lugs.

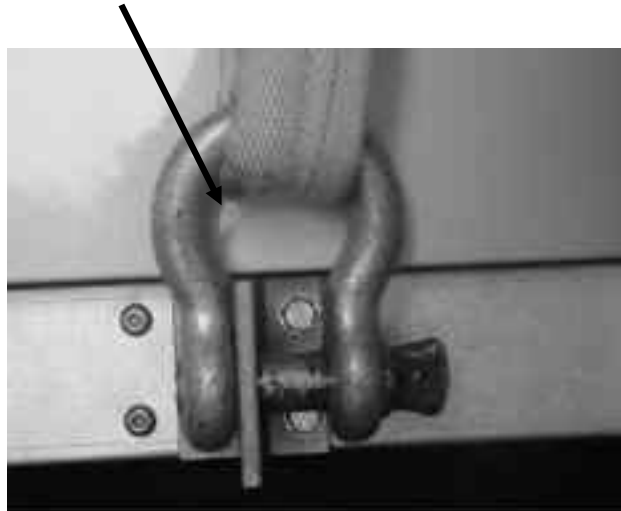

## **FORKLIFT PROTECTIONS**

### **NEVER LIFT THE UNIT WITHOUT FORKLIFT PROTECTIONS**



## **REMOVE THE FORKLIFT PROTECTIONS BEFORE INSTALLATION**

### **PRELIMINARY CHECKS**

Before installing the equipment, the following points **MUST** be checked:

- Have the forklift protections been removed?
- Is there sufficient space for the equipment?
- Is the surface on which the equipment is to be installed sufficiently solid to withstand its weight? A detailed study of the frame must be made beforehand.
- Do the supply and return ductwork openings excessively weaken the structure?
- Are there any obstructing items which could hinder the operation of the equipment?
- Does the electrical power available correspond to the equipment's electrical specifications?
- Is drainage provided for the condensate?
- Is there sufficient access for maintenance?
- Installation of the equipment could require different lifting methods which may vary with each installation (helicopter or crane). Have these been evaluated?
- Ensure that the unit is installed in accordance with the installation instructions and local applicable codes.
- Check to ensure that the refrigerant lines do not rub against the cabinet or against other refrigerant lines.

In general, make sure no obstacles (walls, trees or roof ledges) are obstructing the duct connections or hindering assembly and maintenance access.

## **INSTALLATION REQUIREMENTS**

The surface on which the equipment is to be installed must be clean and free of any obstacles which could hinder the flow of air to the condensers:

- Avoid uneven surfaces
- Avoid installing two units side by side or close to each other as this may restrict the airflow to the condensers.

Before installing a packaged Rooftop unit it is important to understand:

- The direction of prevailing winds
- The direction and position of air flows.
- The external dimensions of the unit and the dimensions of the supply and return air connections.
- The arrangement of the doors and the space required to open them to access the various components.

## **CONNECTIONS**

- Ensure that all the pipe-work crossing walls or roofs are secured, sealed and insulated.
- To avoid condensation problems, make sure that all pipes are insulated according to the temperatures of fluids and type of rooms.

**NOTE:** The AQUILUX protection sheets fitted to the finned surfaces must be removed prior to start up.



**MINIMUM CLEARANCE AROUND THE UNIT**

Figure 4 shows the required clearances and service access around the unit.

NOTE: Ensure the fresh air inlet does not face prevailing wind direction.

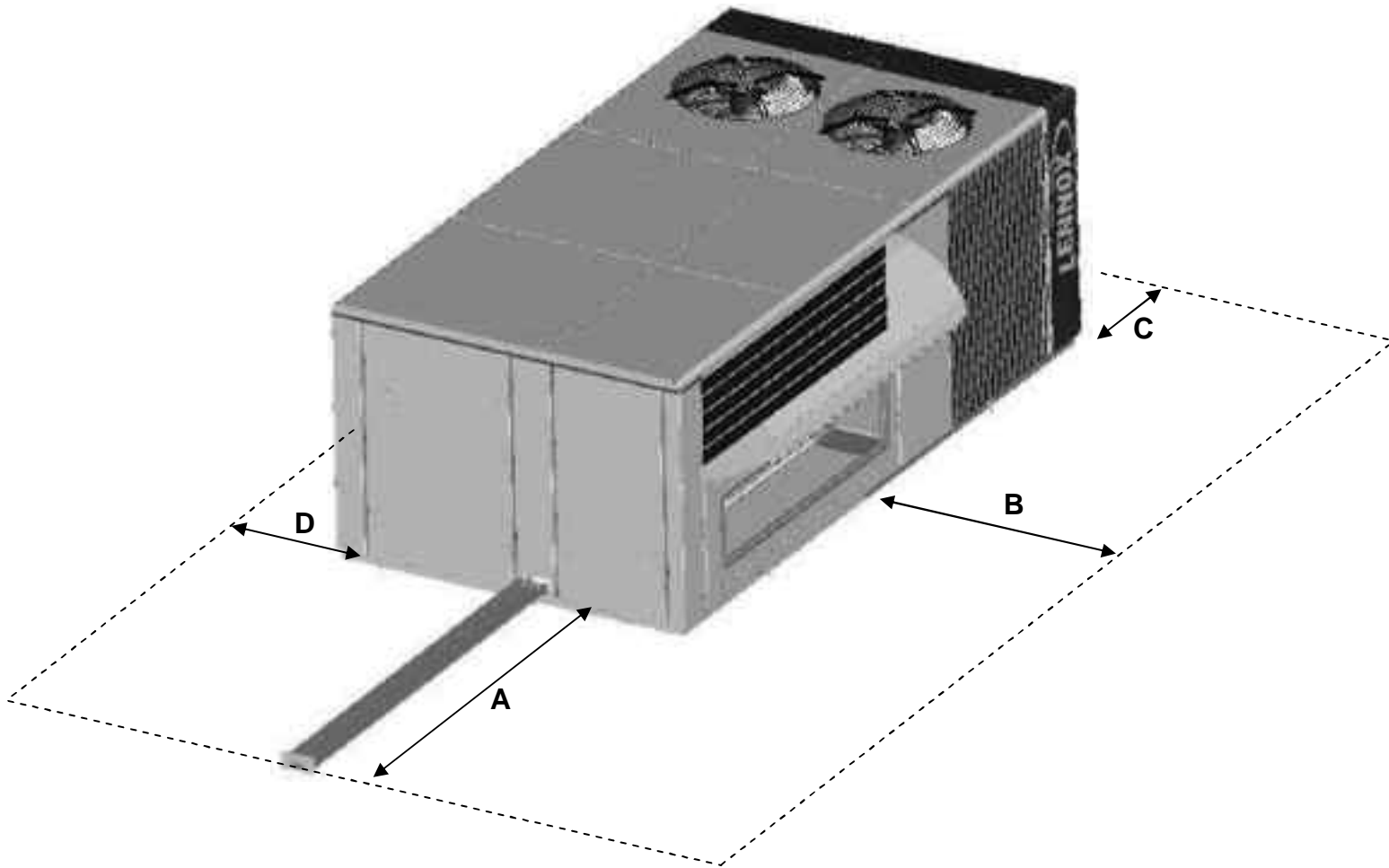

	A	B	C	D
<b>FCM/FHM/FGM/FDM</b>				
F BOX	2200 <sup>(1)</sup>	2000	2000	2000
G BOX	2700 <sup>(1)</sup>	2000	2000	2000
H BOX	2700 <sup>(1)</sup>	2000	2000	2000
<b>FX</b>				
25 & 30	*	1100	*	1700
35→55	*	1300	*	2300
70→100	*	1700	*	2300
110→170	*	2000	*	2300

(1) Add 1 meter if the units are equipped with gas burner

**CAUTION:**

- An approach ramp must be installed if the unit's installation requirements tell that it's necessary to reach the main switch. This recommendation is valid for installations in general and in particular for return and curbs. It's also valid to reach other parts of the unit: filters, refrigerant circuit, etc...
- It's advised to fix curbs and roofcurbs to the unit.

As levels are adjustable, observe the following recommendations when installing the equipment

Above all, ensure that all the adjustable returns are facing outward ("1" figure 4). They are usually turned inside-out for transport.

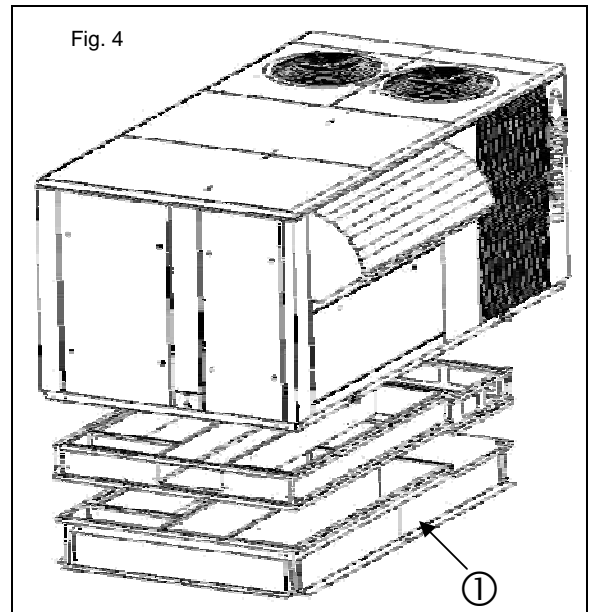



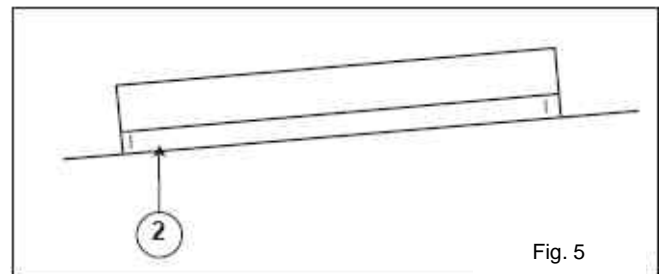

Place the roof mounting frame on the trimmer beam by first lining up the inlet and the outlet opening. ("2"- figure 5)

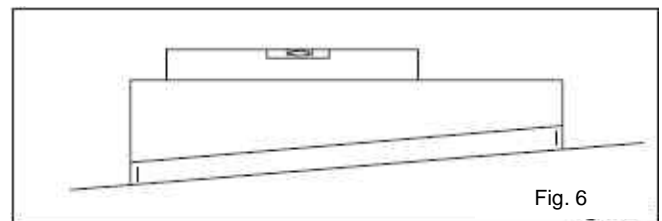

After levelling the frame, secure the adjustable returns on the trimmer.

It is important to centre the unit on the roof frame



When the frame is correctly positioned, it is essential to secure the assembly with a disconnected stitched welded seam (20 to 30mm every 200mm    ) along the outside or by using an alternative method

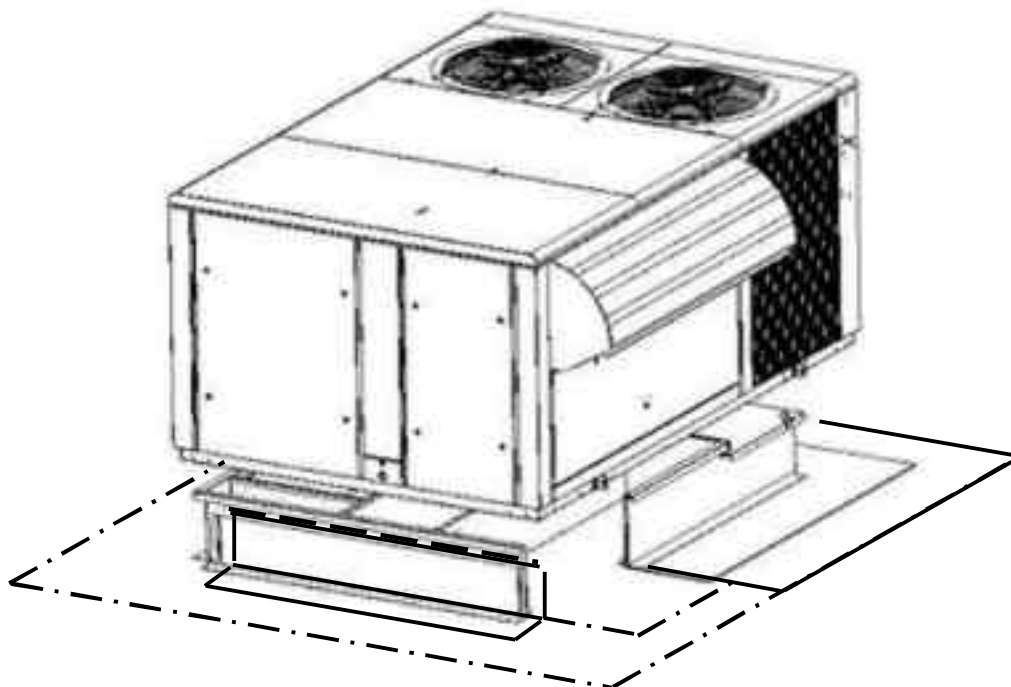

**CURBING AND FLASHING**

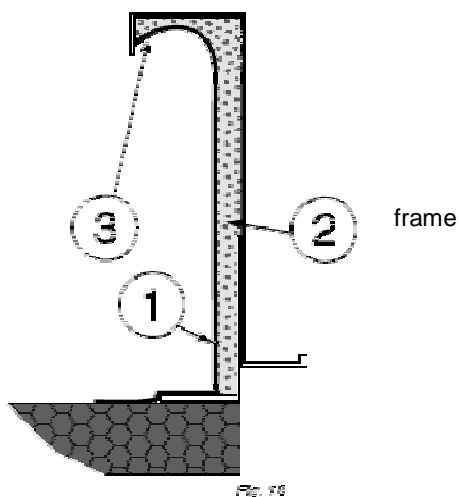

Fig. 7

Outside of frame must be insulated with rigid type insulation;  
We recommend a minimum of 20 mm thick insulation (2-figure 7).

Check that the insulation is continuous, counter flash and seal around the  
as shown in (1-figure 7).

**CAUTION:** To be effective, the upstream must end below the drop edge (3 - figure 7).

Where pipes and electrical conduits extend through the roof, flashing must be conformed to local codes of practice.

Before installing the equipment, make sure that seals are not damaged and check that the unit is secured to the mounting frame. Once in position, the bottom of the equipment must be horizontal.  
The installer must comply with local authority standards and specifications.

**RECOMMENDATIONS FOR DUCTS CONNECTIONS**

Some rules must be complied with for the connections between ducts and unit done on site.

Whatever the supply configuration is, respect a minimal duct's length (**D**) of 2m before any elbow or any duct's diameter change.

These recommendations are imperative in the case of 2 independent turbines (sizes from 150kW to 230kW and all units equipped with gas module)

**Horizontal supply**

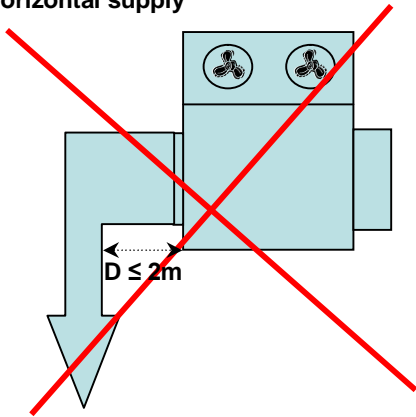

**GOOD CONNECTION**

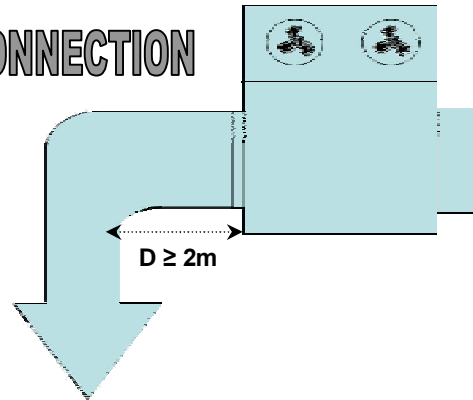

**Vertical supply**

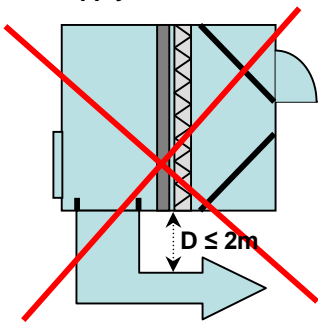

**GOOD CONNECTION**

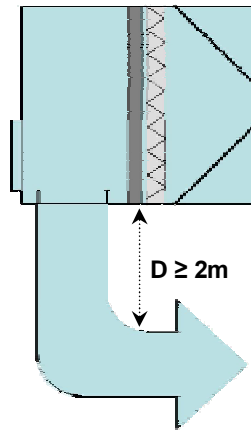

Here are obvious bad examples of ducts connections noted on site:



**NON ADJUSTABLE NON ASSEMBLED ROOFCURB INSTALLATION**

**FRAME PARTS IDENTIFICATION**

Figure 8 shows the different parts used in the assembly of this roof mounting frame.

**INSTALLATION**

The roof mounting frame provides support when the units are installed in down-flow configurations. The non adjustable, non assembled roof mounting frame can be installed directly on decks having adequate structural strength or on roof supports under deck.

NOTE: frame assembly must be installed flat, leveled within 5mm per linear meter in any direction

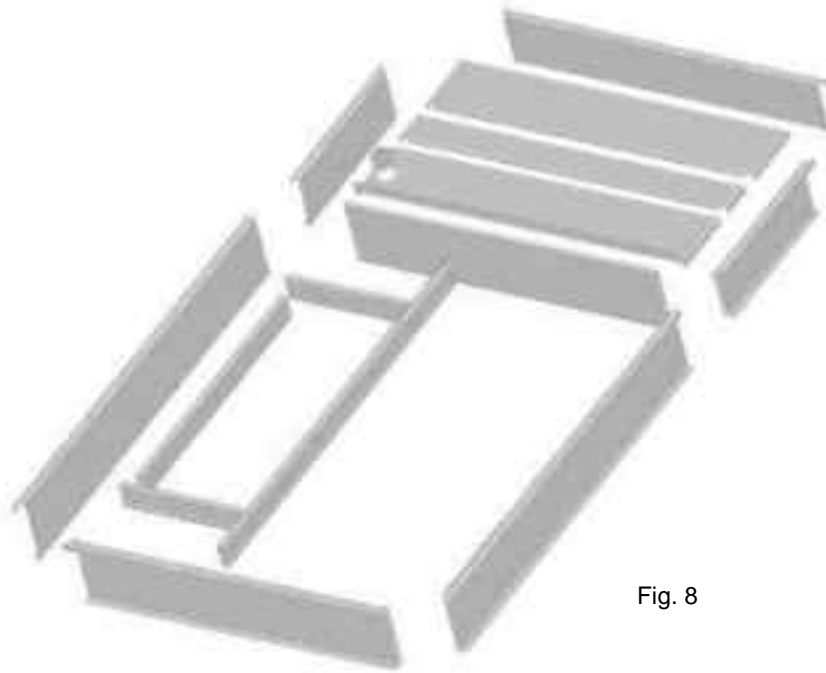
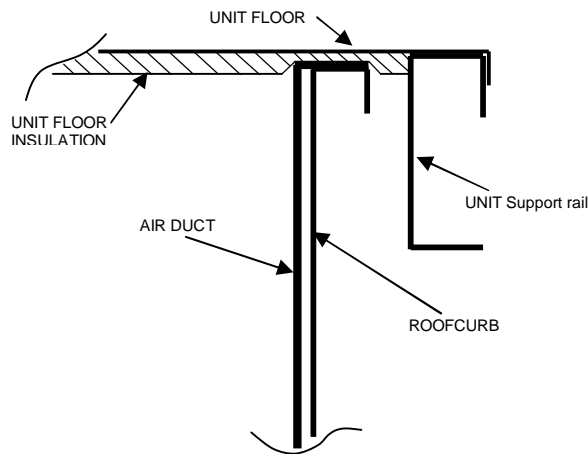

Fig. 8



This roof curb will arrive as a packaged on a pallet and need to be built together. The part will be connected by special corrosion free nails. It is not possible to connect with standard nail equipment because there is a lot of power needed. Therefore, you need a pneumatic or electric device.

**Foam Insulation Installing**

- Stick large foam pieces underneath the flat top

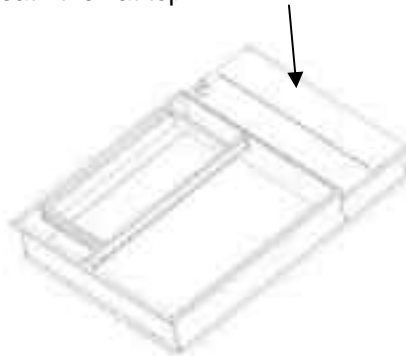

**Foam Gasket Installing**

- Stick gasket all around the curb flange's top

Let it free on 200 mm long to enable water drainage

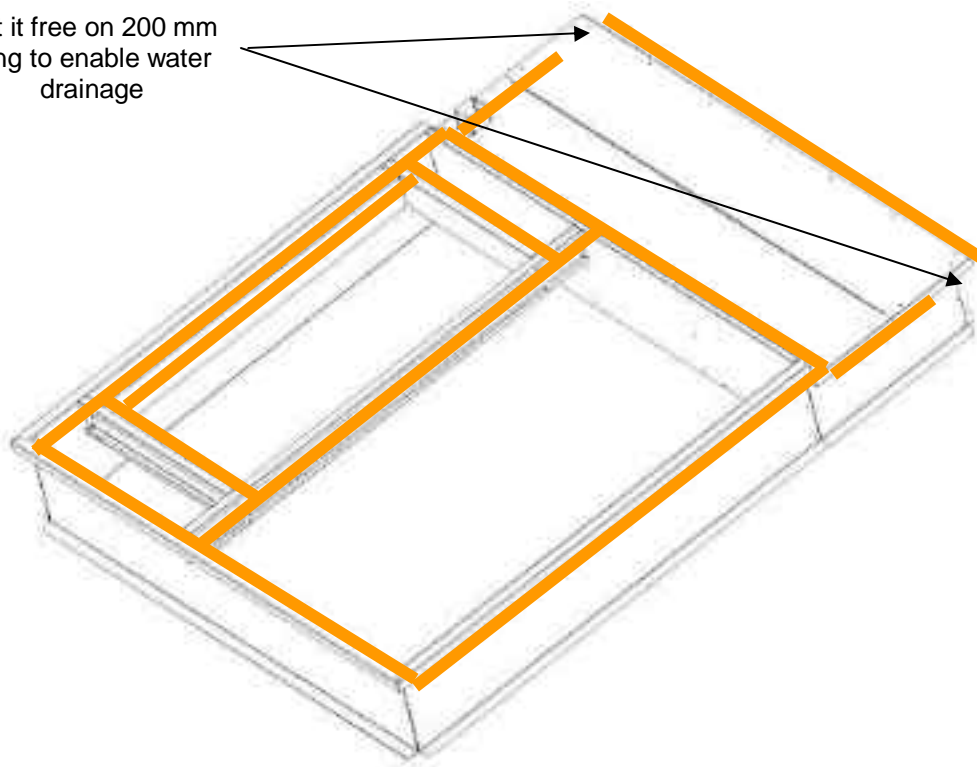

**Spare parts**

	<b>Fbox</b>	<b>Gbox</b>	<b>Hbox</b>
GASKET 5840071R Grey foam M1	17 m / 0.85 m <sup>2</sup>	19 m / 0.95 m <sup>2</sup>	21 m /1.1 m <sup>2</sup>
INSULATION 5840071R	760 x 1960 - 1.39 m <sup>2</sup>	920 x 1960 - 1.79m <sup>2</sup>	tbd
Rivets 5820542X 4.8 x 8 mm	100	130	160

# All units

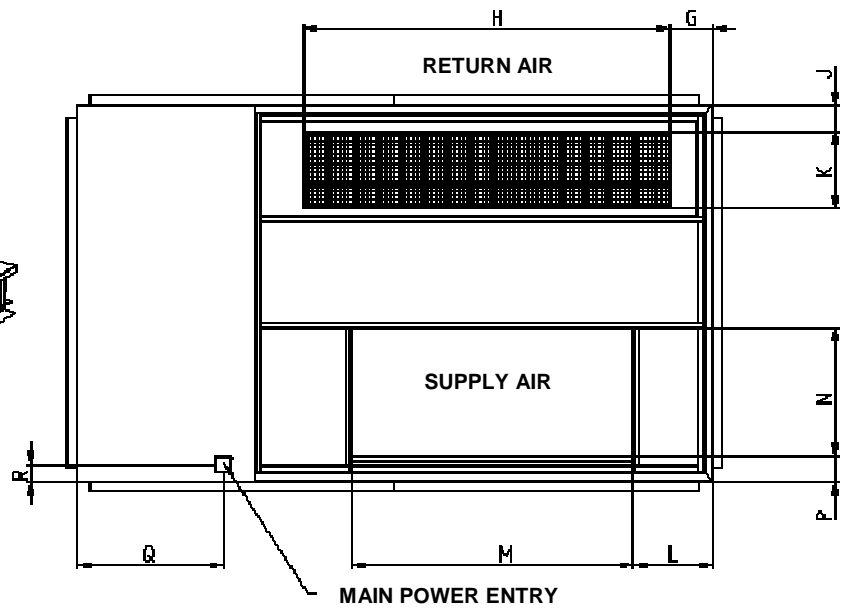
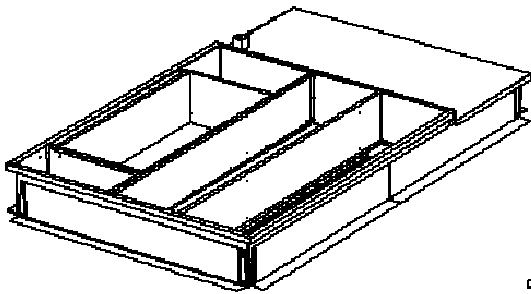
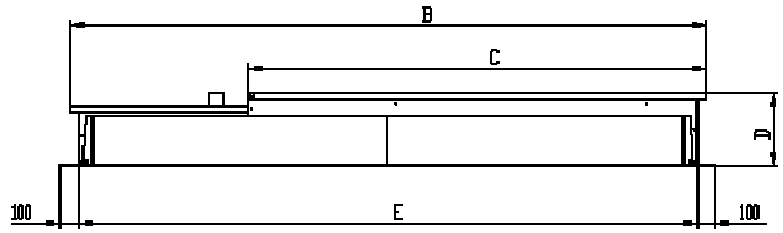
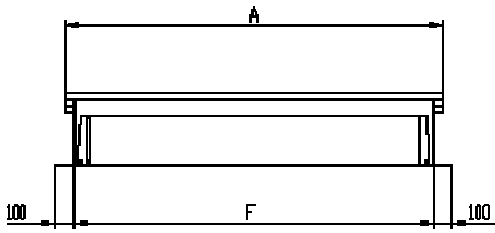

	SIZE	A	B	C	D	E	F	G	H	J	K	L	M	N	P	Q	R
F-BOX	85-100-120	2056	2770	2005	400	2672	1959	130	1747	145	420	336	1432	700	140	620	95
G-BOX	150-170	2056	3466	2493	400	3367	1959	234	1997	145	420	430	1540	700	140	800	95
H-BOX	200-230	2056	4100	2493	400	4003	1959	234	1997	145	420	430	1830	800	80	1133	95

# All units

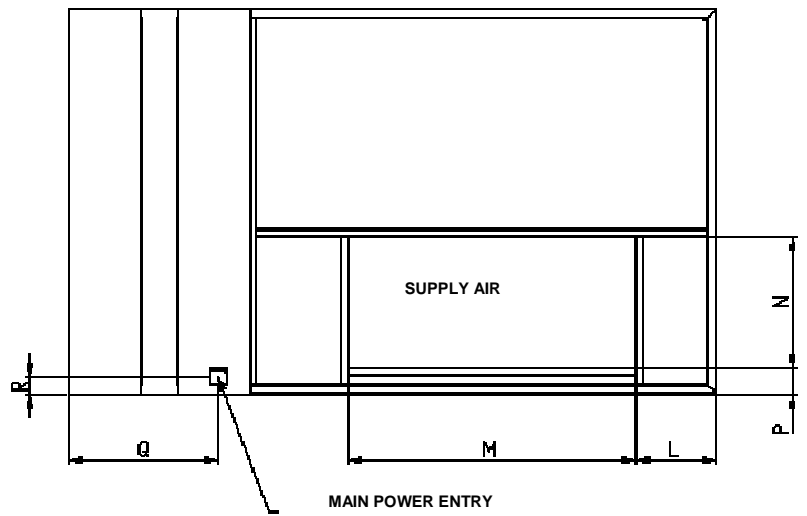
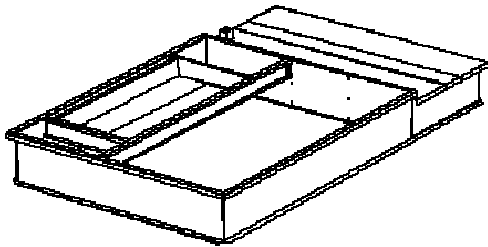
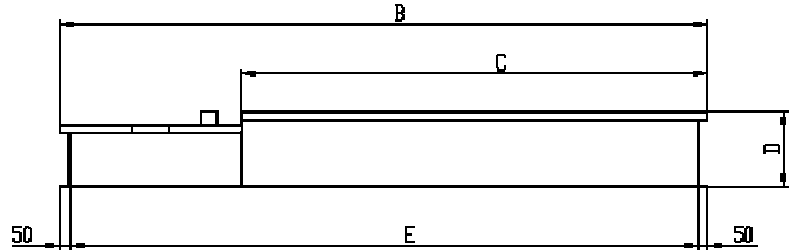
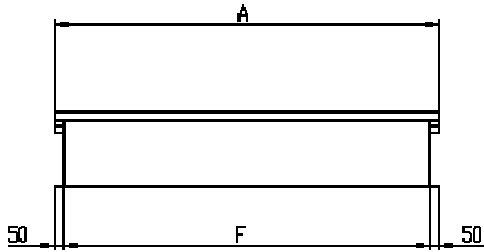

	SIZE	A	B	C	D	E	F	G	H	J	K	L	M	N	P	Q	R
F-BOX	85-100-120	2056	2770	2005	400	2672	1959	130	1747	145	420	336	1432	700	140	620	95
G-BOX	150-170	2056	3466	2493	400	3367	1959	234	1997	145	420	430	1540	700	140	800	95
H-BOX	200-230	2056	4100	2493	400	4003	1959	234	1997	145	420	430	1830	800	80	1133	95



All units

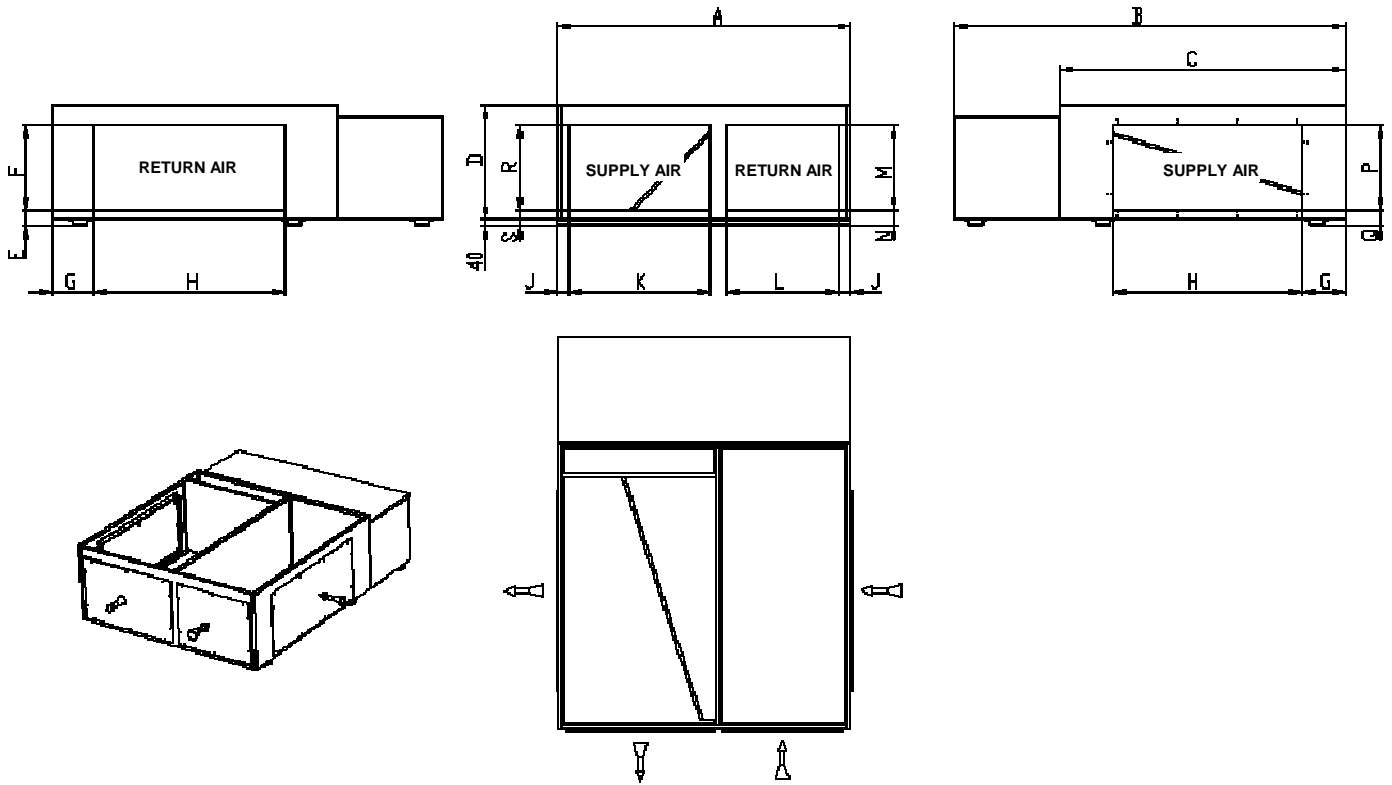

	SIZE	A	B	C	D	E	F	G	H	J	K	L	M	N	P	Q	R	S
F-BOX	85-100-120	2056	2745	2005	800	100	600	300	1335	88	980	780	600	100	600	100	600	100
G-BOX	150-170	2056	3441	2493	800	100	600	300	1540	88	980	780	900	100	600	100	900	100
H-BOX	200-230	2056	4063	2493	800	100	600	300	1830	88	980	780	1000	100	600	100	1000	100

All units

**CAUTION:** An approach ramp must be installed if the machine installation requirements tell that it's necessary to reach the main switch. This recommendation is valid for installations in general and in particular for return and curbs. It's also valid to reach other parts of the unit: filters, refrigerant circuit, etc...

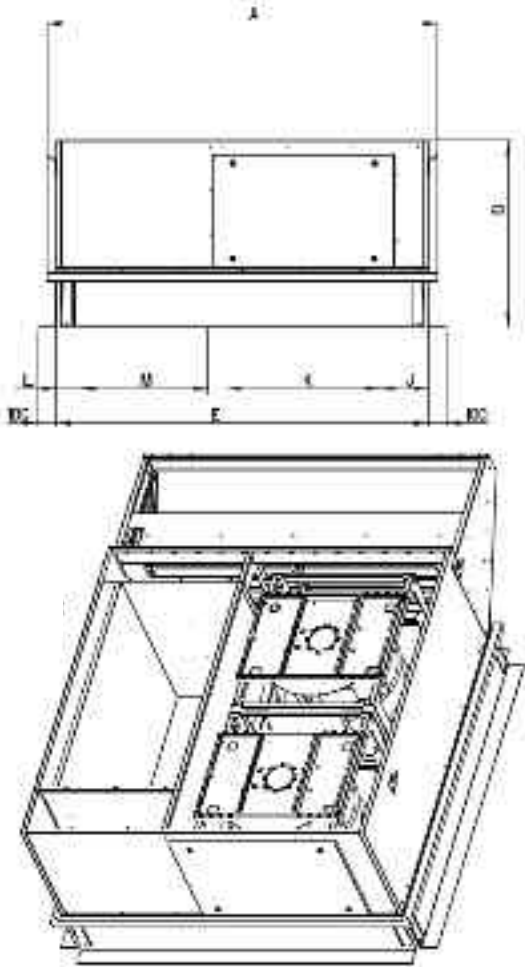
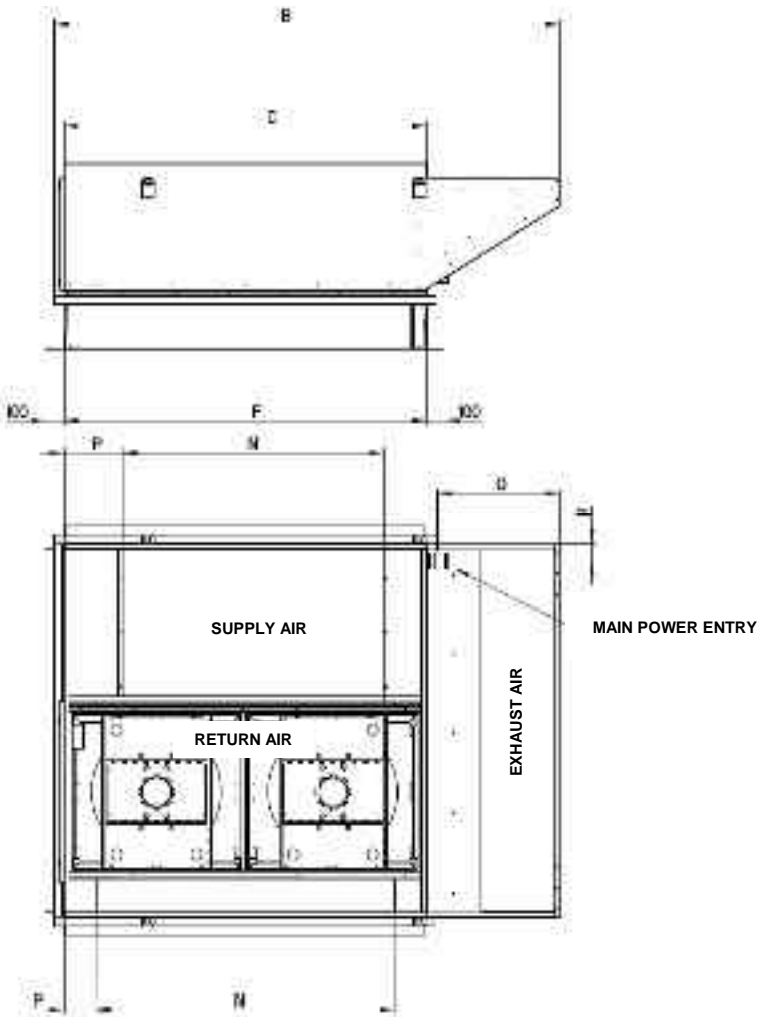

	SIZE	A	B	C	D	E	F	G	H	J	K	L	M	N	P	Q	R
F-BOX	85-100-120	2156	2740	2005	1030	2056	2005	1650	180	310	840	140	700	1440	326	593	95
G-BOX	150-170	2156	3437	2494	1030	2056	2494	1650	410	310	840	140	700	1540	434	770	95
H-BOX	200-230	2156	4073	2494	1030	2056	3294	2550	100	310	840	80	800	1830	434	1113	95

**CAUTION:** An approach ramp must be installed if the machine installation requirements tell that it's necessary to reach the main switch. This recommendation is valid for installations in general and in particular for return and curbs. It's also valid to reach other parts of the unit: filters, refrigerant circuit, etc...

All units

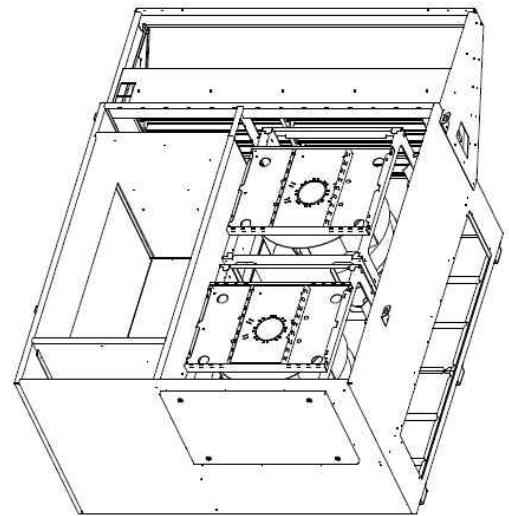
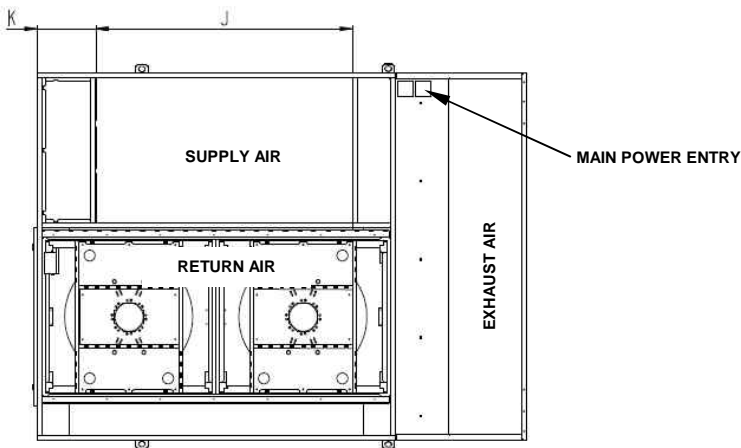
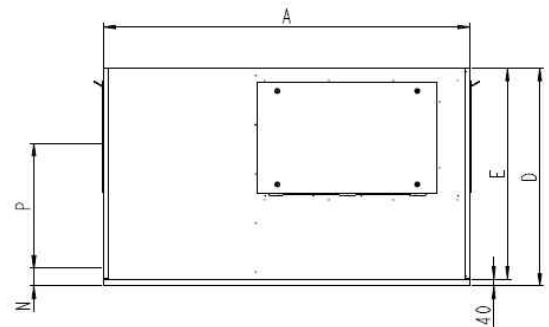
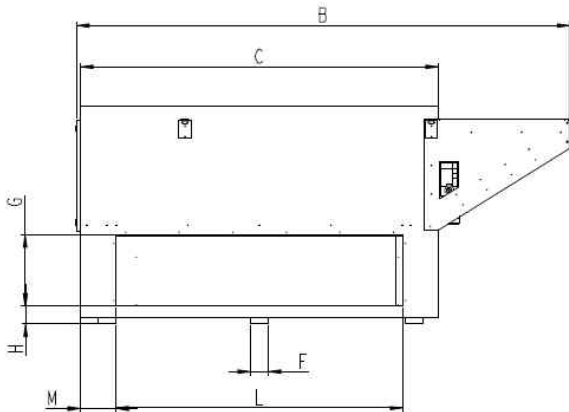

	SIZE	A	B	C	D	E	F	G	H	J	K	L	M	N	P
F-BOX	85-100-120	2056	2755	2005	1220	1180	100	400	100	1335	200	1605	200	100	700
G-BOX	150-170	2056	3465	2493	1220	1180	100	400	100	1540	200	2000	200	100	700
H-BOX	200-230	2056	4095	2493	1305	1205	200	400	150	1830	150	2293	100	260	700

# All units

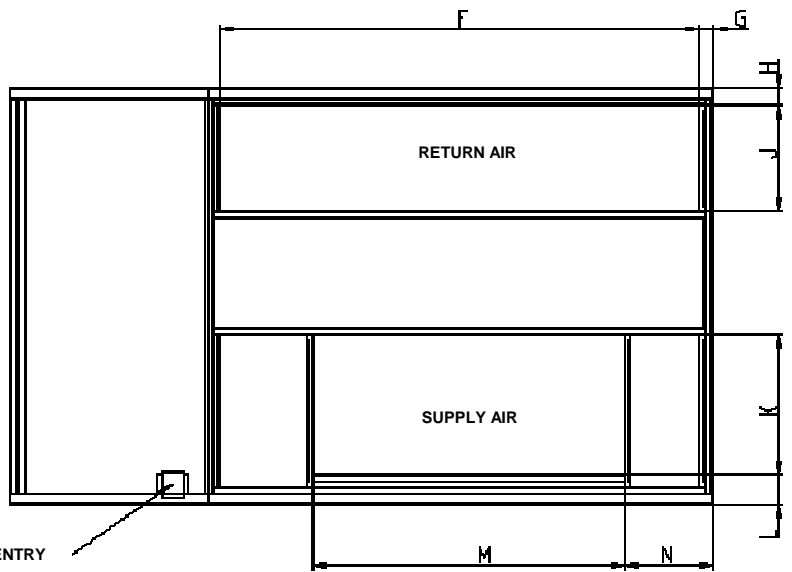
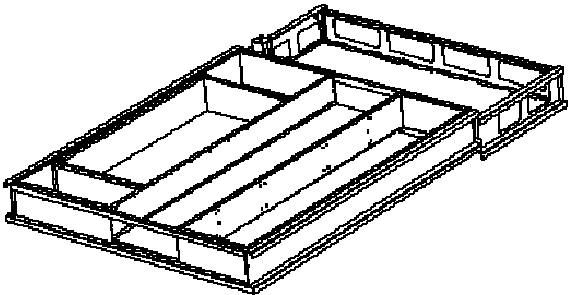
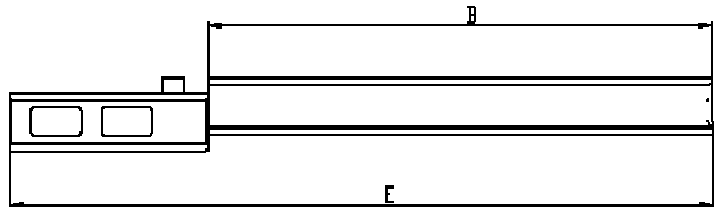
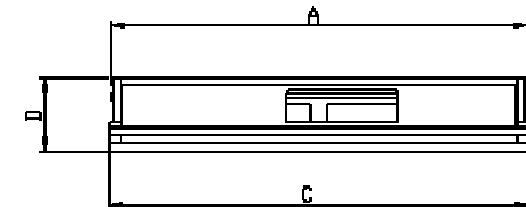

	SIZE	A	B	C	D	E	F	G	H	J	K	L	M	N
F-BOX	85-100-120	2056	2008	2072	366	2783	1880	70	85	530	700	145	1432	342
G-BOX	150-170	2056	2496	2072	366	3480	2377	70	85	530	700	145	1540	440
H-BOX	200-230	2056	2493	2072	366	4106	2377	70	85	530	800	85	1830	440

**All units**

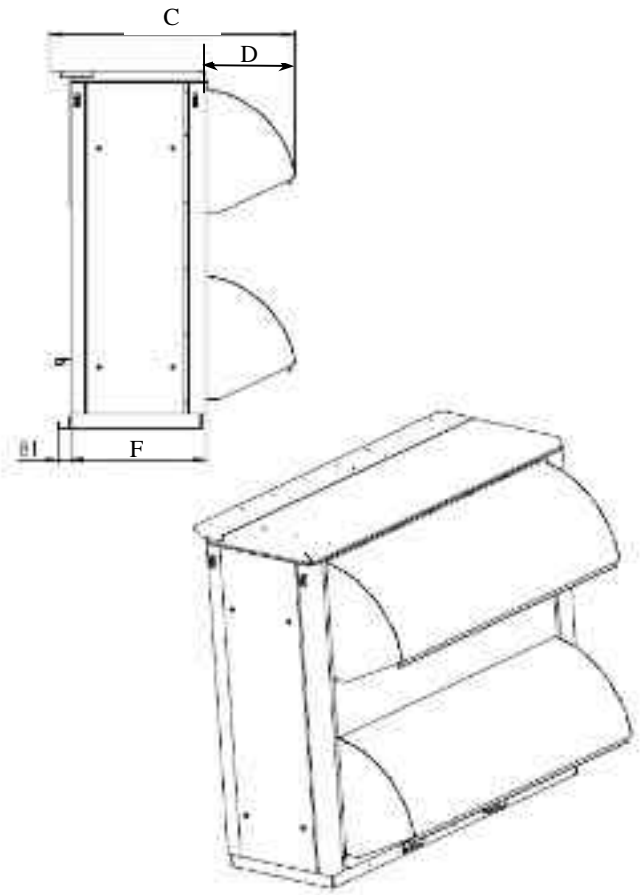
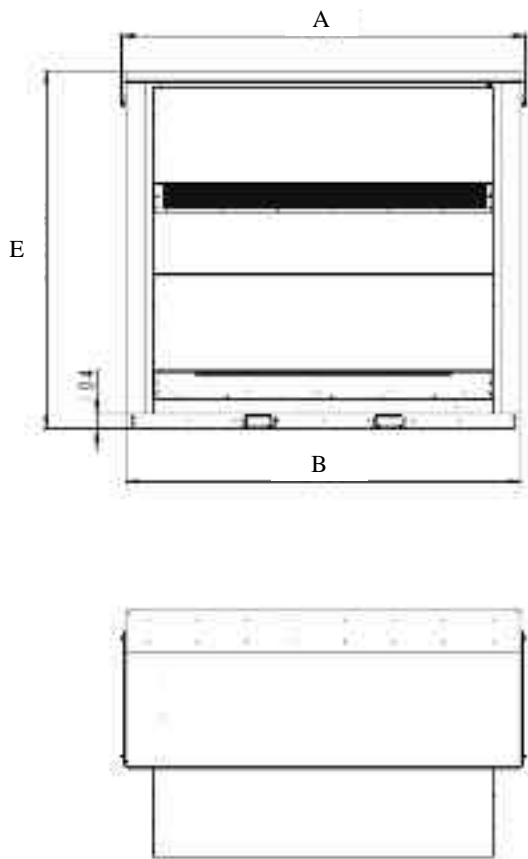

	SIZE	A	B	C	D	E	F
F-BOX	85-100-120	2279	2212	1447	360	1911	938
G-BOX	150-170	2539	2473	1544	457	2211	938
H-BOX	200-230	2789	2723	1703	616	2461	938

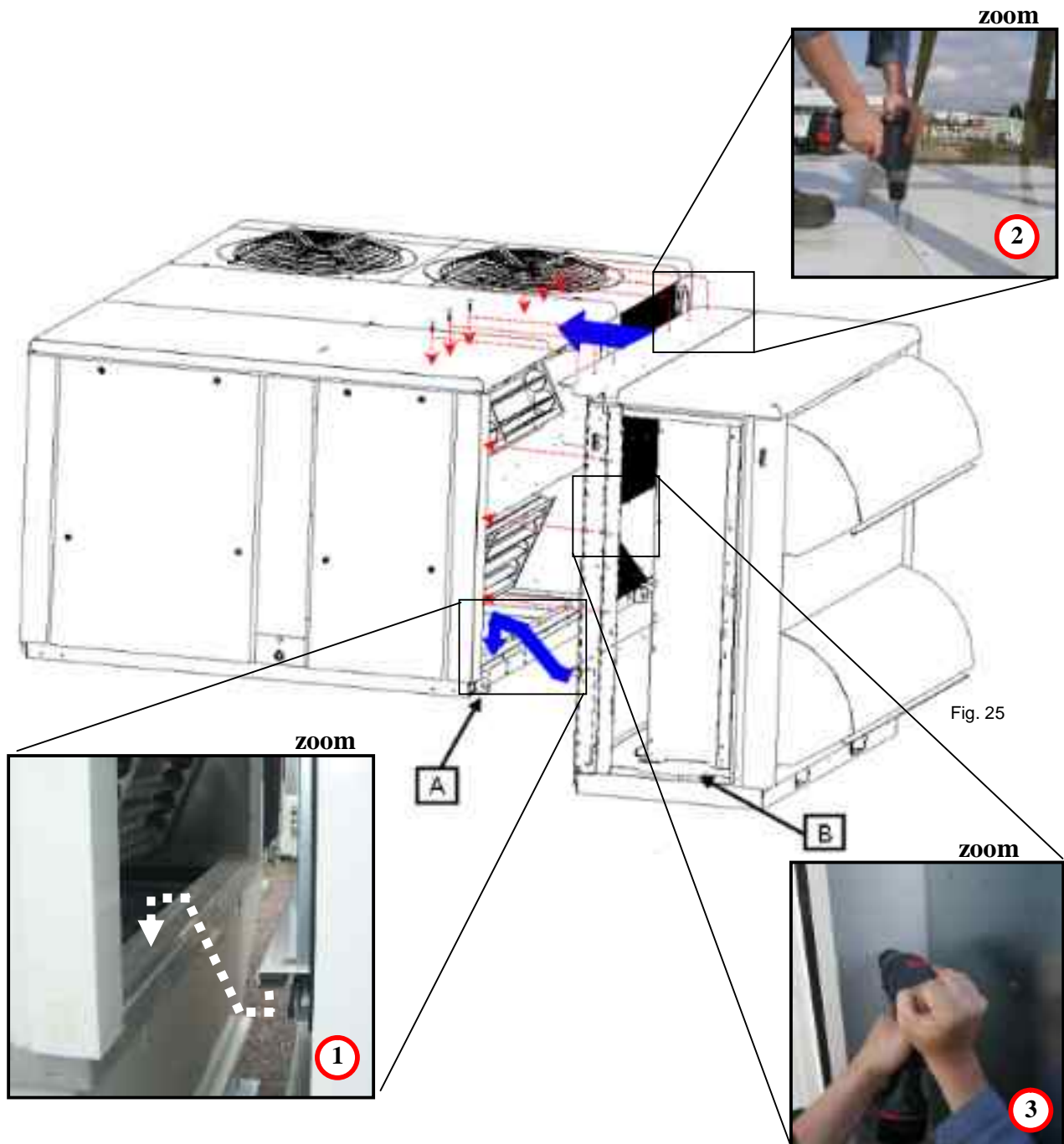

- 1) The unit being already erected on the roofcurb, remove the lifting lug shown on [A], and the doors of the Recovery module [B].
- 2) Fit the support part of the Recovery Module on interior level of the rooftop ①,
- 3) Fix the Recovery Module at the roof of the rooftop ② and corner structures ③ by using self-drilling screws.
- 4) Apply Mastic on side junctions and on higher junction.

**ECONOMISER**

Free cooling can be provided through the use of fresh air which is more appropriate than excessive cooling amounts of return air. The economiser is factory fitted and tested prior to shipment. It includes two dampers operating from a 24V actuator

**RAIN HOOD**

It also includes a factory fitted rain hood. Hoods is folded during transportation to limit risks of damage and must be unfolded on site as shown on fig. 9

**EXTRACTION**

Installed with economiser assembly, the gravity exhaust dampers relieve the pressure when outside air is introduced into the system.

When large amount of fresh air is introduced into the system power exhaust fans can be used to equalise the pressures.

The extraction fan runs when return air dampers are being closed and supply air blower is in operation. The extraction fan runs when outdoor air dampers are at least 50% open (adjustable value). It is overload protected.

NOTE: When horizontal flow configuration is required, the multidirectional roof curb will be installed.



Fig. 9

**0-25% FRESH AIR MANUAL**

It is enough to loosen the mobile grid's screws and to make it slip.

0%: screw into limit stop on the right

25%: screw into limit stop on the left

FLEXY II PRINCIPLE SKETCH

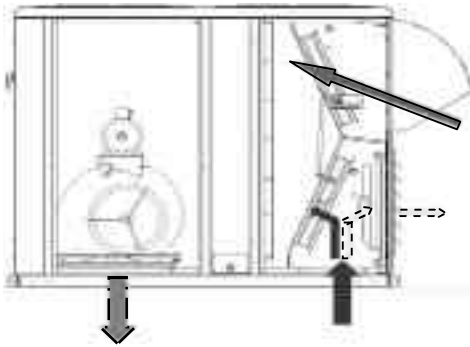

MULTIDIRECTIONAL ROOFCURB PRINCIPLE SKETCH

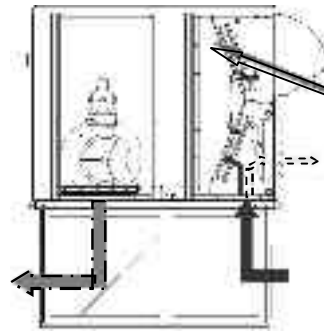

ENERGY RECOVERY MODULE PRINCIPLE SKETCH

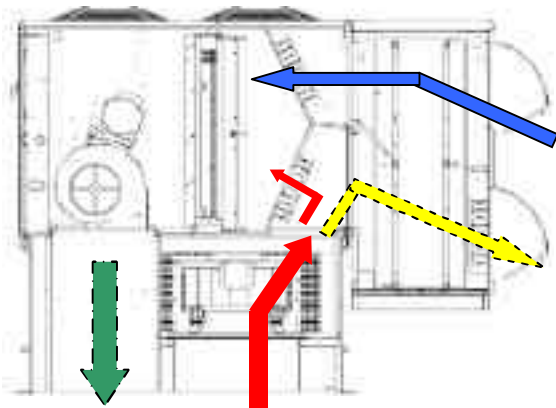

RETURN ROOFCURB PRINCIPLE SKETCH

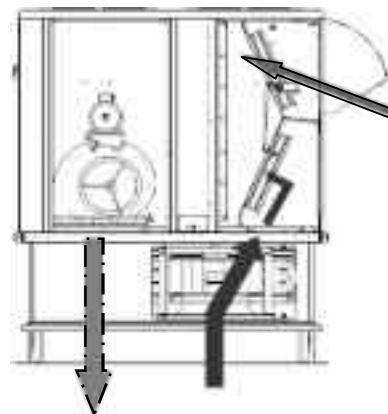

- FRESH AIR
- RETURN AIR
- EXHAUST AIR
- SUPPLY AIR

**THIS WORK MUST ONLY BE CARRIED OUT BY TRAINED REFRIGERATION ENGINEERS**

FILL THE COMMISSIONING SHEET AS YOU GO ALONG



**Don't forget to open the isolation Valves on the liquid line before starting the unit (see sticker below)**



**ISOLATION VALVES MUST BE OPENED BEFORE RUNNING**

G1  G2

**ELECTRICAL CONNECTIONS**

- Ensure that the power supply between the building and the unit meets local authority standards and that the cable specification satisfies the start-up and operating conditions.

**ENSURE THAT THE POWER SUPPLY INCLUDES 3 PHASES**

- Check the following wire connections for tightness: Main switch connections, mains wires linked to the contactors and circuit breakers and the cables in the 24V control supply circuit.

How to connect roof curbs and energy recovery module



Energy recovery cable fixed on the grid of the roofcurb

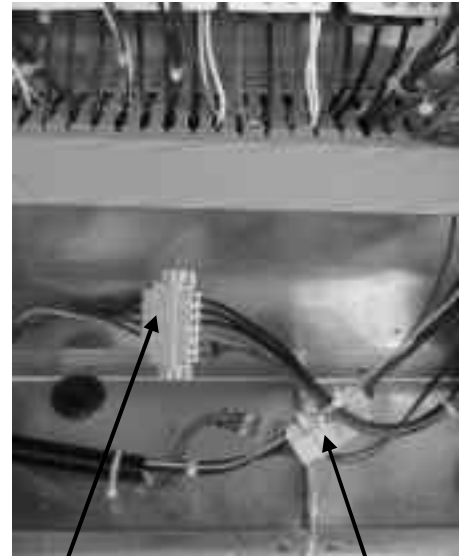

Connector for the energy recovery module

Connector for the extraction roof curb

Cables and their connectors corresponding to the roof curb' motor and actuator and extraction box' ones are already rolled up in these elements; it is enough to bring them through the openings envisaged and to connect them on the sites.

It's the same procedure when you have an energy recovery module.

**PRELIMINARY CHECKS**

- Ensure that all drive motors are secure.
- Ensure that the adjustable pulley blocks are secure and that the belt is tensioned with the transmission correctly aligned. Refer to the next section for details.
- Using the electrical wiring diagram, check the conformity of the electrical safety devices (circuit breaker settings, presence and rating of fuses).
- Check the temperature probe connections.





**STARTING THE UNIT**

At this point the unit circuit breakers should be open  
 You will need a **DS50** maintenance controller or Adalink with appropriate Interface.

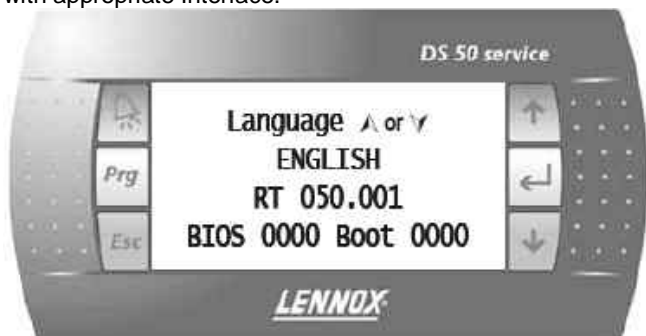

The jumpers are factory set and the configuration switches are adjusted depending on the option the type of unit.  
 Connecting the CLIMATIC displays



Close the 24V Control Circuit breakers.



The CLIMATIC 50 starts after 30s

Reset the DAD photo (If fitted)



**Check and adjust the control settings.**

Refer to the control section in this manual to adjust the different parameters.

**POWERING THE UNIT**

- Power up the unit by closing the isolator switch (if fitted).
- At this point the blower should start unless the climatic does not energise the contactor. In this particular case the blower can be forced by bridging the port NO7 and C7 on connector J14 on the Climatic. Once the fan is running, check the rotation direction. Refer to the rotation arrow located on the fan.
- The fans and compressors direction of rotation is checked during the end of line test. They should therefore all turn in either the right or wrong direction.

NOTE: A compressor rotating in the wrong direction will fail.

- If the fan turns in the wrong direction (the right direction is shown on figure n° 11), disconnect the main power supply to the machine at the building's mains switch, reverse two phases and repeat the above procedure.
- Close all circuit breakers and power up the unit, remove the bridge on connector J14 if fitted.
- If now only one of the components rotates in the wrong direction, disconnect the power supply at the machine's isolator switch (if fitted) and reverse two of the component's phases on the terminal within the electrical panel.
- Check the current drawn against the rated values, in particular on the supply fan (ref. page 33).
- If the readings on the fan are outside the specified limits, this usually indicates excessive air flow which will affect the life expectancy and the thermodynamic performances of the unit. This will also increase the risks of water ingress into the unit. Refer to the "Air Flow Balancing" section to correct the problem.

At this point attach the manometers to the refrigerant circuit

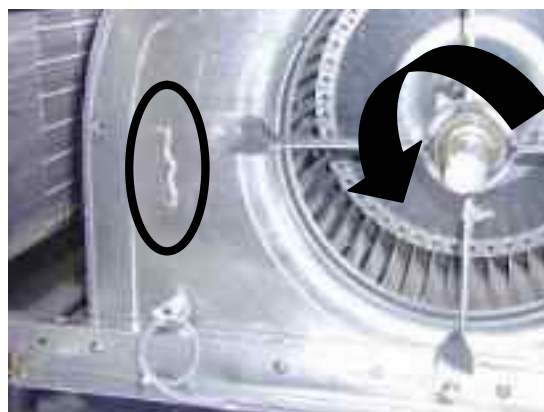

Fig. 11

**RUN TEST**

Start unit in cooling mode



Thermodynamic readings using manometers and prevailing environmental conditions

No rated values are given here. These depend on the climatic conditions both outside and inside the building during operation. However, an experienced refrigeration engineer will be able to detect any abnormal machine operation.

**Safety test**

- Check Air pressure switch (if fitted) "Dirty filter" detection test: vary the set-point value (menu page 3413 on DS50) in respect to the air pressure value. Observe the response of the CLIMATIC™.
- Same procedure for detecting "Missing Filter" (page menu 3412) or "Air Flow Detection" (page menu 3411).
- Check the smoke detection function (if fitted).
- Check the Firestart by pressing the test button (if fitted).
- Disconnect the circuit breakers of the capacitor fans and check the high pressure cut-out points on different refrigerant circuits.

**Reverse cycle test**

This test is designed to check the good operation of the 4-way reversing valves on heat pump reversible systems. Start the reverse cycle by adjusting the cold or hot temperature threshold data according to the indoor and outdoor conditions at the time of test (**menu 3320**).

**BELT TENSION**

On delivery, the drive belts are new and correctly tensioned. After the first 50 operating hours check and adjust the tension. 80% of the total elongation of belts is generally produced during the first 15 hours of operation.

Before adjusting the tension, make sure that the pulleys are correctly aligned.

To tension the belt, set the height of motor support plate by moving the plate adjustment screws.

The recommended deflection is 20 mm per meter from centre to centre.

Check that according to the diagram below (figure 12), the following ratio remains the same.

$$\frac{A \text{ (mm)}}{P \text{ (m)}} = 20$$



- The belts should always be replaced when:
- The disk is set to maximum,
  - The belt rubber is worn or the wire is visible.

Replacement belts must have the same rated size as the ones they are replacing. If a transmission system has several belts, they must all be from the same

**NOTE:**

An under-tensioned belt will slip, heat and wear prematurely. On the other hand, if a belt is over-tensioned, the pressure on the bearings will cause them to over-heat and wear prematurely. Incorrect alignment will also cause the belts to wear prematurely.

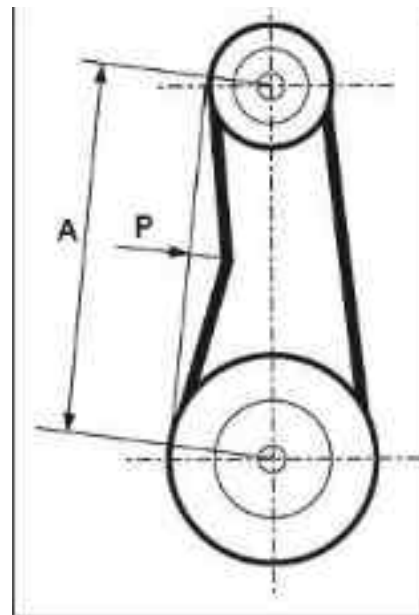

Fig. 12

**MOUNTING AND ADJUSTING PULLEYS**

**FAN PULLEY REMOVAL**

Remove the 2 screws and put one of them in the extraction threaded screw.

Screw in fully. The hub and the pulley will separate from each other.

Remove the hub and the pulley by hand without damaging the machine.

**FAN PULLEY INSTALLATION**

Clean and de-grease the shaft, hub and conical bore of the pulley. Lubricate the screws and install the hub and pulley. Position the screws without turning them.

Place the assembly on the shaft and screw in the screws alternatively and evenly. Using a mallet or a hammer with a wooden wedge, tap on the face of the hub to keep the assembly in place. Torque the screws to 30 Nm.

Take the pulley in both hands and shake it vigorously to make sure everything is in place.

Fill the holes with grease for protection.

**NOTE:** During installation, the key should never protrude out of its groove.  
After 50 operating hours, check that the screws are still in place.

**MOTOR PULLEY INSTALLATION & REMOVAL**

The pulley is held in position by the key and a screw located in the groove. After unlocking, removing this screw by pulling against the shaft spindle (if necessary, use a mallet and tap uniformly on the hub to remove it). To assemble, proceed in the reverse order after having cleaned and de-greased the motor shaft and the pulley bore.

**PULLEYS ALIGNMENT**

After adjusting one or both of the pulleys, check the transmission alignment using a ruler placed on the inner face of the two pulleys.

**NOTE:** The warranty may be affected if any major modification is made to the transmission without obtaining our agreement beforehand.

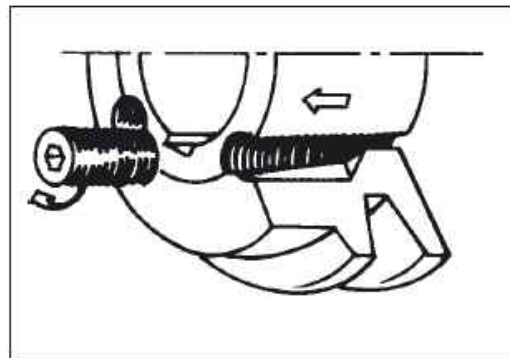

The actual resistance of ductwork systems is not always identical to the calculated theoretical values. To rectify this, it may be necessary to modify the pulley and belt setting. To this effect, the motors are fitted with variable pulleys.

**SITE TEST AND MAINTENANCE**

**Measure the motor absorbed power.**

If the absorbed power is greater and the pressure lower than the rated values, the ventilation system has a lower pressure drop than anticipated. Reduce the flow by reducing the rpm. If the system resistance is significantly lower than design, there is a risk that the motor will overheat resulting in an emergency cut out.

If the absorbed power is lower and the pressure greater than the rated values, your system has a higher pressure drop than anticipated. Increase the flow by increasing the rpm. At the same time you will increase the absorbed power which may result in having to increase the motor size.

To carry out the adjustment and to avoid a time-consuming re-start, stop the machine and if necessary lock the main switch. First unscrew the 4 Allen screw(s) on the pulley (see figure 13).

Pulley type	Pulley External Diameter	Min Dia / Min Dist	Max Dia / Max Dist	Nb of turns from fully closed to fully open	Actual diameter (DM) or distance between faces for a given number of turns from fully closed with SPA belt in (mm)										
					0.5	1	1.5	2	2.5	3	3.5	4	4.5	5	5.5
8450 / D8450	120	95	116	5	114	112	110	108	106	103	101.3	99.2	97.1	95	-
		20.2	28	5	21	21.8	22.5	23.3	24.1	24.9	25.7	26.4	27.2	28	-
8550 / D8550	136	110	131	5	129	127	125	123	121	118	116	114	112	110	-
		20.6	31.2	5	21.6	22.7	23.8	24.8	25.9	26.9	28	29.1	30.1	31	-

Table\_1

The easiest way to determine the fan rotation speed is to use a Tachometer. If not available the fan rpm can be estimated using the following two methods.

1<sup>st</sup> Method with the pulley secured in place:

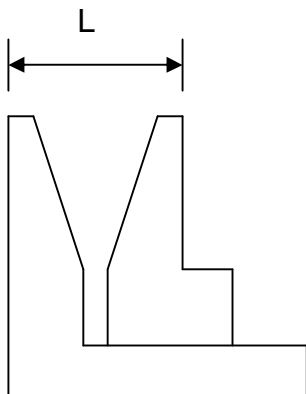

Measure the distance between the two outside faces of the pulley. Using table (1) the motor pulley actual diameter can be estimated.

ALLEN WRENCH 4

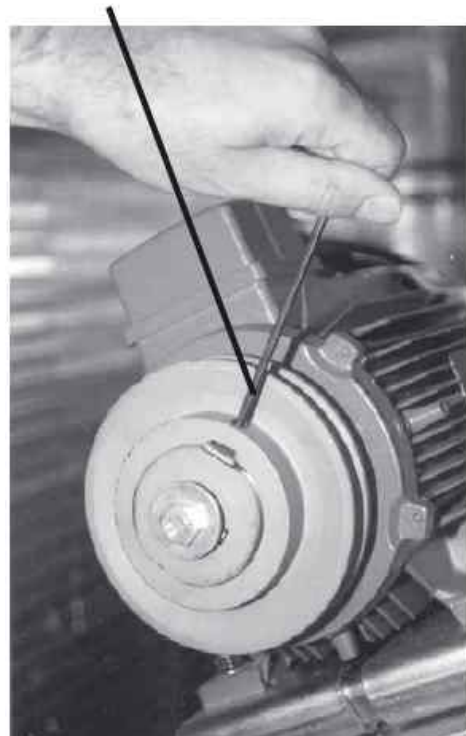

Fig. 13

2<sup>nd</sup> method when adjusting the pulley :

- Close the pulley fully and count the number of turns from fully closed position. Using table\_1 determine the motor pulley actual diameter.
- Record the fix fan pulley diameter.(DF)
- Determine the fan speed using the following formulae:

$$rpm_{FAN} = rpm_{MOTOR} \times D_M / D_F$$

Where: rpm<sub>MOTOR</sub> :from the motor plate or table\_2  
 D<sub>M</sub> : from table\_1  
 D<sub>F</sub>: from machine

Once the pulleys are adjusted and the belt checked and tensioned, start the fan motor and record the Amps and Voltage between the phases:  
 Using the measured data and table\_2

-Theoretical mechanical power at the fan shaft:

$$P_{meca fan} = P_{meca Motor} \times \eta_{Transmission}$$

$$P_{meca fan} = P_{elec} \times \eta_{meca motor} \times \eta_{Transmission}$$

$$P_{meca fan} = V \times I \times \sqrt{3} \times \cos\phi \times \eta_{meca motor} \times \eta_{Transmission}$$

This formula can be approximated in this way

$$P_{meca fan} = V \times I \times 1.73 \times 0.85 \times 0.76 \times 0.9$$

With the fan “rpm” and the mechanical power at the fan shaft an operating point and the supplied airflow can be estimated using the fan curves.

CHECKING AIRFLOW AND ESP

Using the fan curves on page 36 to 40, the airflow, the total pressure available (P<sub>TOT</sub>) and the corresponding dynamic pressure (Pd) can now be estimated, for a specific operating point;

The next step consists in estimating the pressure losses across the unit.

This can be achieved using the “dirty filter pressure sensor” and the accessories pressure drop table: table\_3  
 Also the pressure drop due to the duct inlet into the roof-top unit can be taken as 20 to 30 Pa.

$$\Delta P_{INT} = \Delta P_{filter + coil} + \Delta P_{Inlet} + \Delta P_{Options}$$

Using the results from above, the external static pressure (ESP) can then be estimated:

$$ESP = P_{TOT} - Pd - \Delta P_{INT}$$

Table\_2 Motor information

Motor Size	Nom. Speed	Cos φ	η <sub>meca motor</sub>
0.75 kW	1400 rpm	0.77	0.70
1.1kW	1429 rpm	0.84	0.77
1.5kW	1428 rpm	0.82	0.79
2.2kW	1436 rpm	0.81	0.81
3.0kW	1437 rpm	0.81	0.83
4kW	1438 rpm	0.83	0.84
5.5kW	1447 rpm	0.85	0.86
7.5kW	1451 rpm	0.82	0.87
9.0kW	1455 rpm	0.82	0.88
11.0kW	1451 rpm	0.85	0.88

Table\_3 Accessories pressure drops

	Economiser	G4 Filters	F7 Filters	UV LIGHT	Hot Water coil S	Hot Water coil H	Electric Heater S	Electric Heater M	Electric Heater H	Heating Gaz fired H	Adjustable roofcurb	Multidirectional Roofcurb	Heat Recovery Modul Fresh Air	
85	12000	12	1	75	18	9	15	3	5	6	14	17	22	164
	15000	19	7	105	30	13	22	6	7	7	23	27	33	204
	23000	45	28	199	63	26	44	7	9	11	53	63	73	313
100	14000	17	5	94	26	11	19	6	7	8	20	23	30	191
	18500	29	15	143	44	18	31	8	10	11	34	41	51	252
	23000	45	28	199	63	26	44	11	14	16	53	63	78	313
120	15000	19	7	105	30	13	22	7	8	9	23	27	35	204
	20500	36	21	167	52	21	37	10	12	13	42	50	62	279
	23000	45	28	199	63	26	44	12	15	17	53	63	78	313
150	18000	6	1	75	15	6	10	4	5	7	16	30	35	170
	26000	12	12	130	33	12	19	9	10	13	33	62	72	245
	35000	22	29	204	54	19	33	15	18	23	59	112	131	329
170	21000	8	5	94	21	8	14	8	9	10	21	40	49	198
	30000	16	19	161	42	15	25	10	13	15	44	82	95	282
	35000	22	29	204	54	19	33	17	19	21	59	112	131	329
200	24000	12	3	88	18	7	11	16	15	14	21	53	67	173
	35000	26	18	154	39	13	22	22	21	20	44	112	133	252
	43000	39	31	211	54	19	31	24	26	29	66	169	195	310
230	27000	15	7	105	24	8	14	18	18	17	26	67	84	195
	39000	32	24	182	46	16	26	24	24	25	55	139	163	281
	43000	39	31	211	54	19	31	24	26	29	66	169	195	310

**EXAMPLE**

The unit used for this example is a FGM170ND with standard supply and return airflow configuration. It is also fitted with an economiser and an electric heater type H. It is fitted with 2 ADH450 L fans which curve is shown on page 36 and 2x 5.5 kW motors..

- Motor rpm: 1447 rpm
- $\cos\phi = 0.83$
- Voltage = 400V
- Current = 9.00A (per fan)

$$P_{\text{mech fan}} = V \times I \times \sqrt{3} \times \cos\phi \times \eta_{\text{mech motor}} \times \eta_{\text{Transmission}}$$

$$= 400 \times 9.00 \times \sqrt{3} \times 0.83 \times 0.86 \times 0.9 = \underline{\underline{4.00\text{kW}}}$$

The unit is also fitted with 2 transmission kits 3.

- Fixed Fan pulley: 200mm
- Motor adjustable pulley type "8550" opened 4 turns from fully closed or measured distance between pulley end plates is 29.1mm: from table\_1 it can be determined that each motor pulley has a diameter of **114.2mm**

$$\text{rpm}_{\text{FAN}} = \text{rpm}_{\text{MOTOR}} \times D_M / D_F = 1447 \times 114.2 / 200 = \underline{\underline{826 \text{ rpm}}}$$

Using the fan curve, the operating point can be located.

**In order to facilitate the calculation, you won't make any mistake by considering that the external static pressure available is the one calculated with one fan providing the half of the nominal flow (here 15000m<sup>3</sup>/h).**

It can be determined that the fan is providing approximately 15000 m<sup>3</sup>/h with a total pressure  $P_{\text{TOT}} = \underline{\underline{630 \text{ Pa}}}$

The pressure losses in the unit are the sum of all pressure drops across the different parts of a unit:

- Coil and filter (**measured**) = 89 Pa
- Inlet into the unit = 50 Pa
- Options = 16 Pa for economiser and 15 Pa for electric heater H

$$\Delta P = 89 + 16 + 15 + 50 = \underline{\underline{170 \text{ Pa}}}$$

The dynamic pressure at 15000m<sup>3</sup>/h is given at the bottom of the fan curve.

$$P_d = \underline{\underline{81 \text{ Pa}}}$$

The external static pressure available is therefore

$$ESP = P_{\text{TOT}} - P_d - \Delta P_{\text{INT}} = 630 - 81 - 170 = \underline{\underline{369 \text{ Pa}}}$$

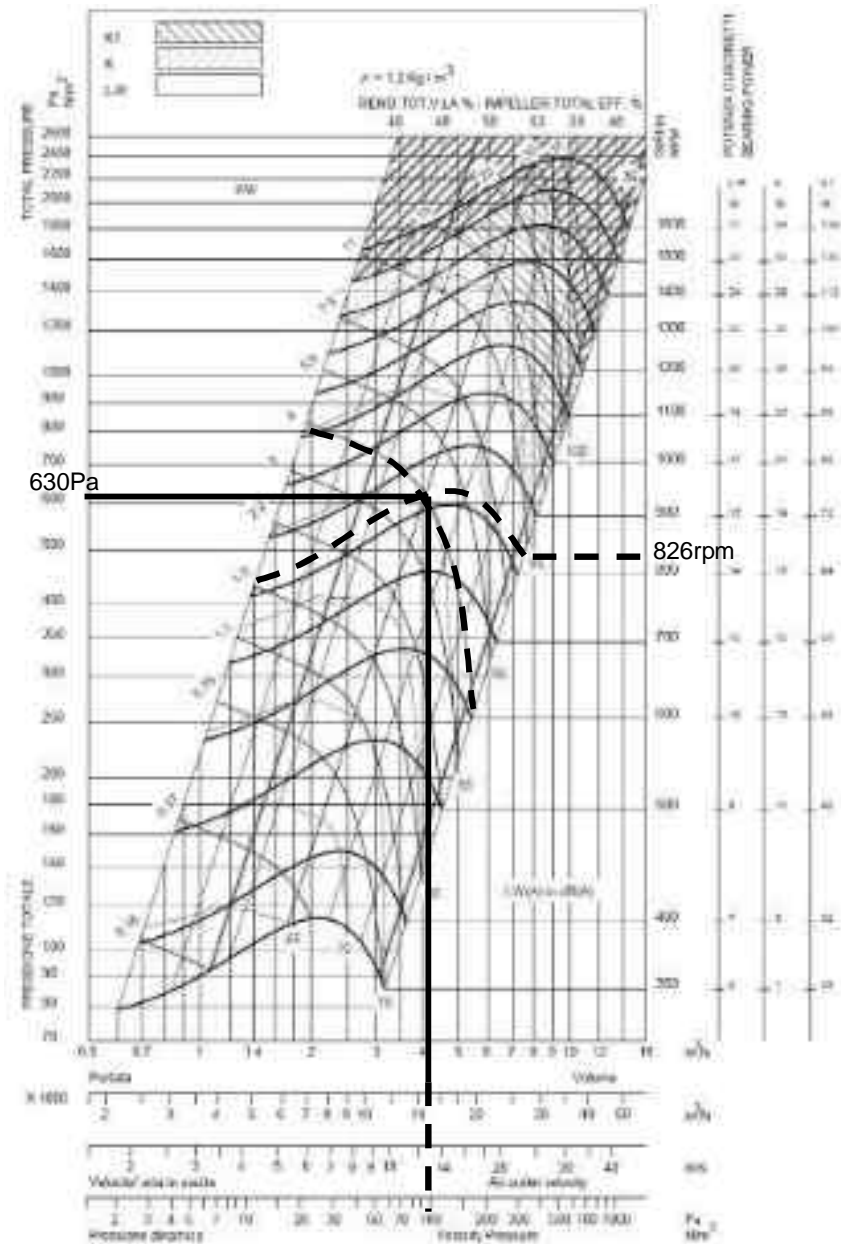

**AT15-15G2L(\*)**

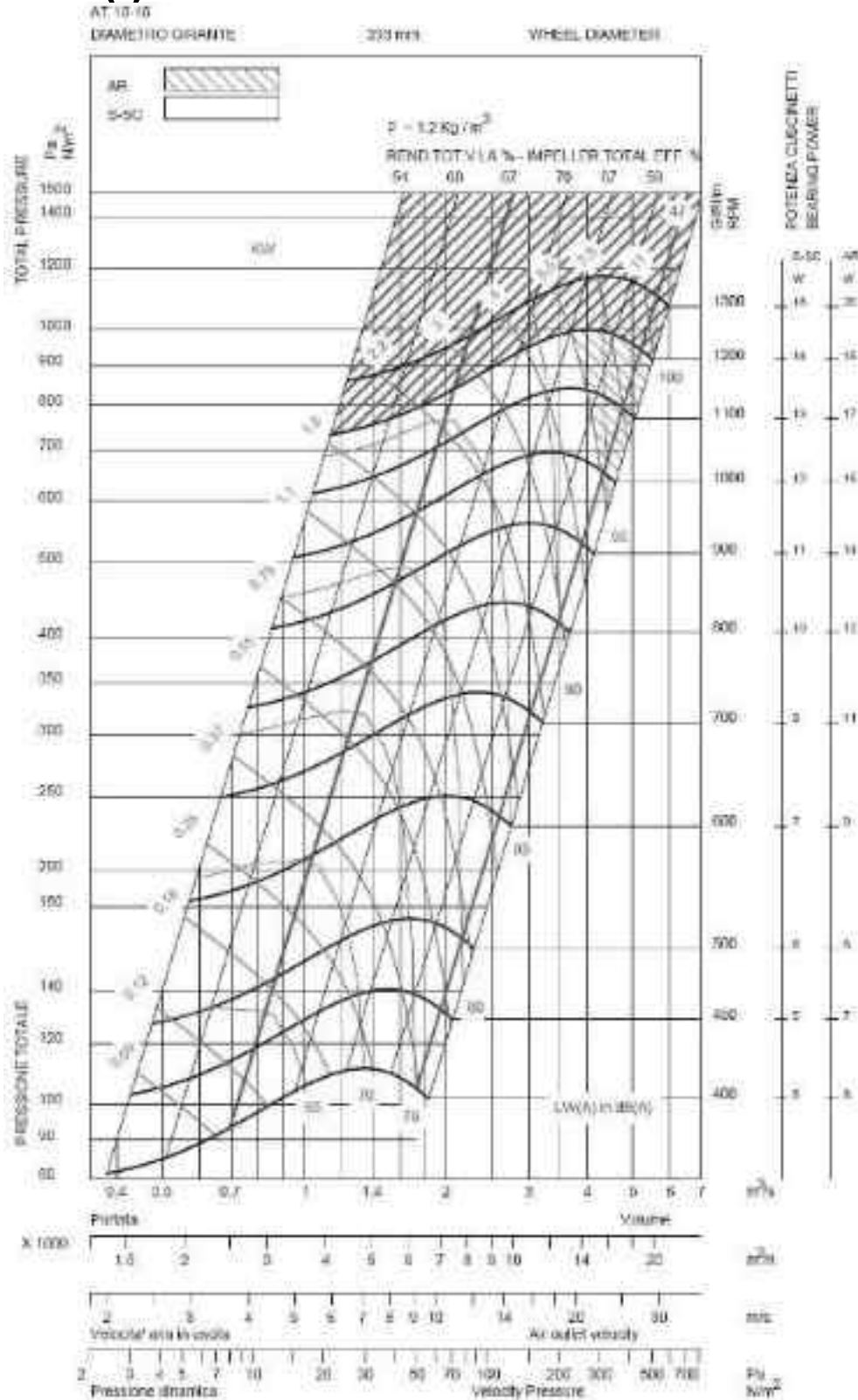

(\*) The performances of twin fan units can be calculated starting from the corresponding operation point for a single fan (see the figure behind) by applying the formulas below.

- pressure :  $PT_{win} = P \times 1$
- volume flow rate :  $Q_b = Q \times 2$
- impeller power:  $W_b = W \times 2,15$
- fan speed :  $N_b = N \times 1,05$
- $L_{ws} : L_{wsb} = L_{ws} + 3 \text{ dB}$



**AT18-18S**

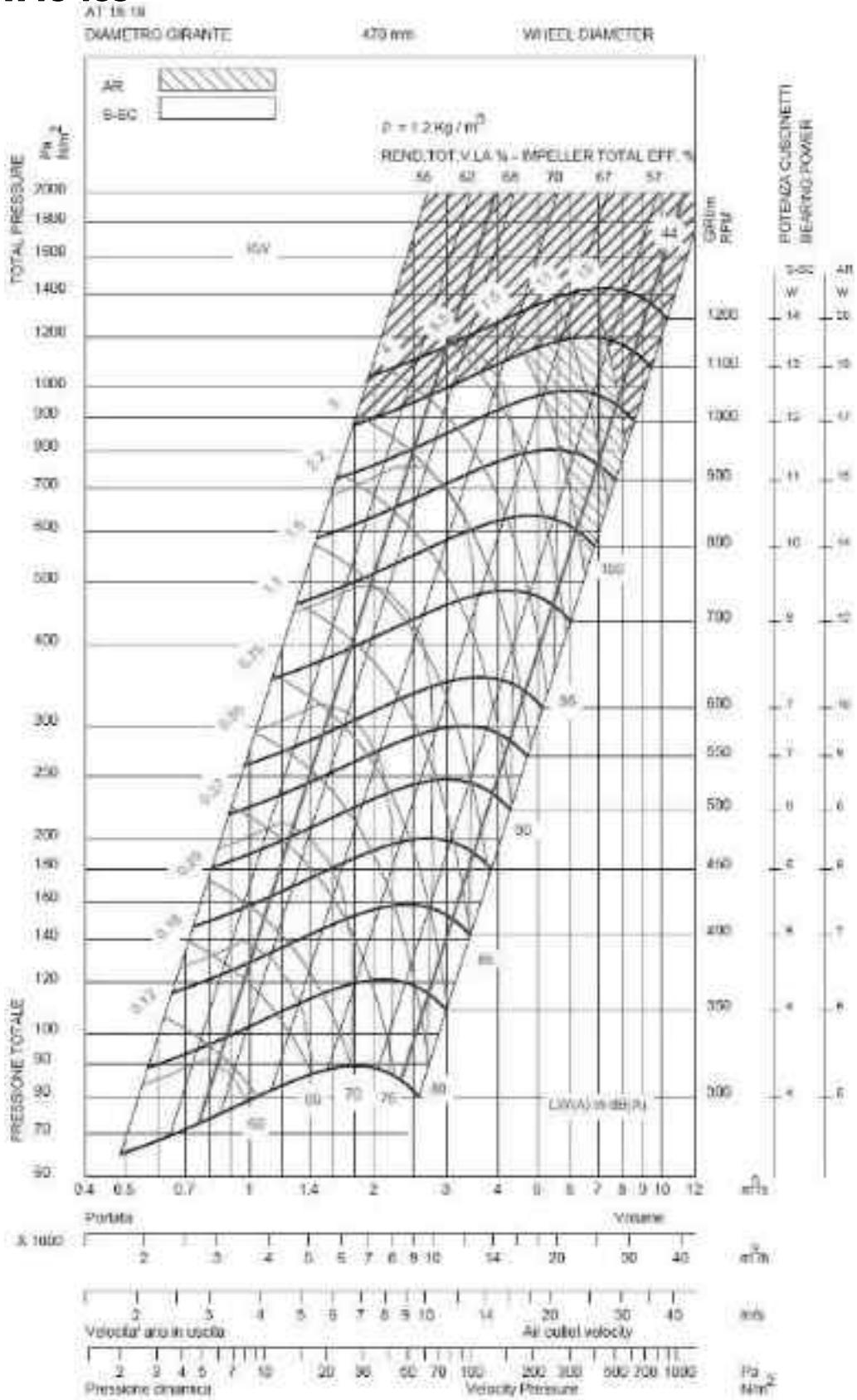

### ADH355L

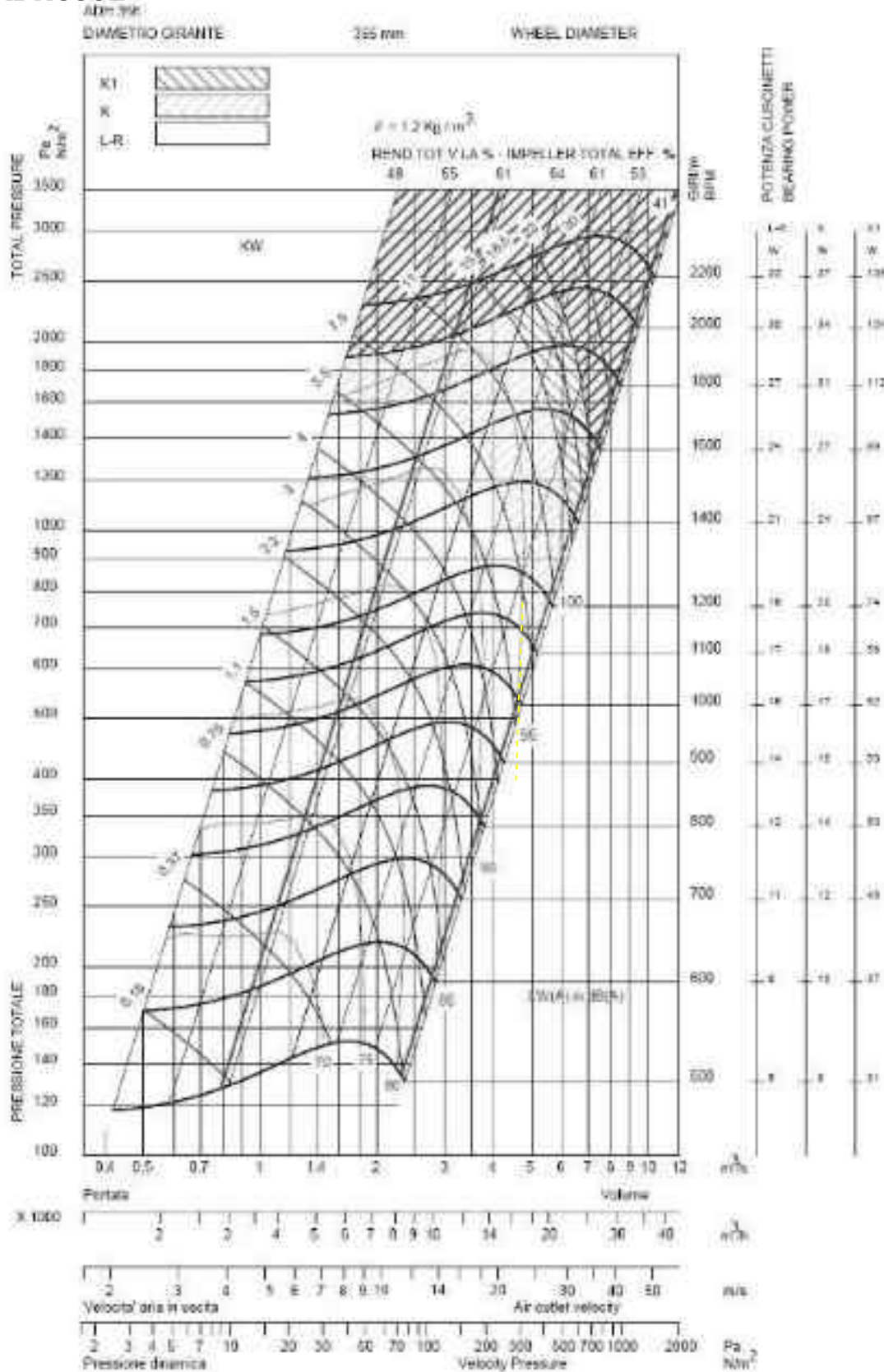

# ADH450L

ADH 450  
 DIAMETRO GIRANTE 450mm WHEEL DIAMETER

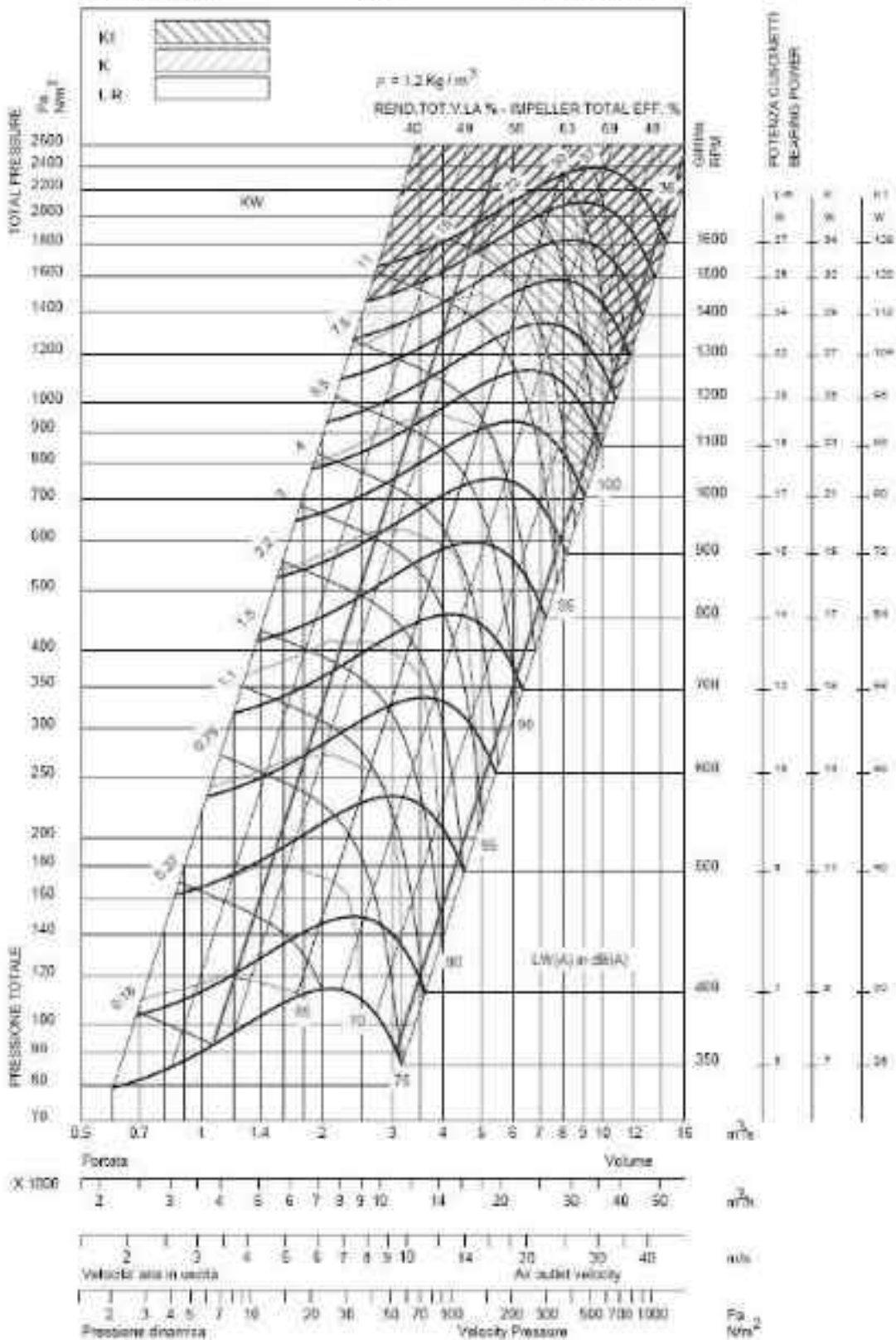

# ADH500L

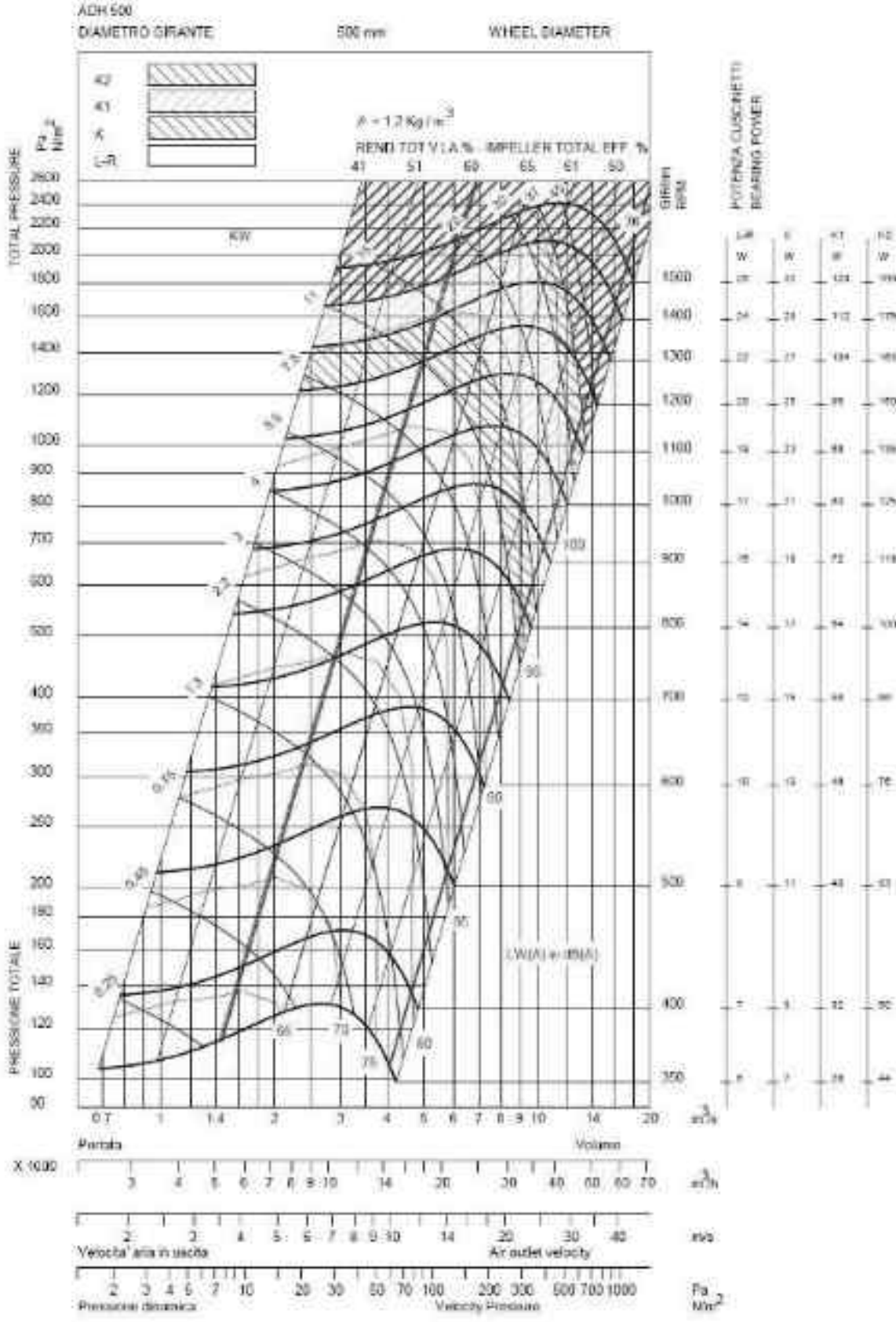

**FILTER REPLACEMENT**

After opening the filter access panel, lift the filter retaining log.  
The filters can then be removed and replaced easily by sliding the dirty filters out and clean ones in.



The CLIMATIC controller can monitor the pressure drop across the filter (If option fitted)

The following set points can be adjusted depending on the installation.

- “Airflow” in page 3411 = 25Pa by default
- “No filter “ in page 3412 = 50Pa by default
- “Dirty Filter” in page 3413 = 250Pa by default

The actual pressure drop measured across the coil can be read on the Climatic Display DS50 in menu 2131.

The following faults may be identified

- Fault code 0001 AIRFLOW FAILURE, if measured  $\Delta P$  across the filter and coil is below the value set in page 3411
- Fault code 0004 DIRTY FILTERS, if measured  $\Delta P$  across the filter and coil is above the value set in page 3413
- Fault code 0005 MISSING FILTERS, if measured  $\Delta P$  across the filter and coil is below the value set in page 3412



**Be Careful: do the filters' fire classification's choice according to the local regulations**

**AIR SOCK CONTROL**

**FANSTART OPERATION**

The use of air socks for space conditioning allows high air volumes to be distributed at low velocity and is becoming a common feature in many applications. To accommodate this trend, Air-sock control is offered which allows the air socks to be progressively filled with air on start up. It takes up to 1 minute to go from 0% of air to full air flow.

**START-UP**

This option requires the economiser to be delivered inside the machine

Both return air and fresh air damper are linked with and independent actuator.

The return air damper is controlled by a spring return damper driven by the opposite signal delivered to the fresh air damper.



An auxiliary switch allows setting a minimum (few %) of return air opening before the fan is switched on.

**Starting steps:**

- Both dampers are fully closed and Fan is OFF
- Rooftop is set to RUN (by the schedule or the remote display order)
- Return air damper move to the minimum position manually adjustable on the auxiliary switch, Fresh air damper is OFF
- Fan motor starts
- Return air damper goes to 100% return air slowly during 1 minute allowing the duct to be smoothly inflated
- Finally, the fresh air damper and return air damper return to adjusted fresh air ratio recorded in the climatic50 program

*The return air damper with its auxiliary switch*

**UV LIGHT**

UV light option allows to kill bacteria living on the fin.

The UV lamp emits shortwave UV-C ultraviolet radiation which is harmful to skin and eyes  
It can cause serious skin burns and eye inflammation within ONE SECOND of exposure

Do not enter the machine while UV are switched on

Make sure the UV light circuit breaker is OFF when opening the return air section door and the supply air section doors

The following logo will appear to inform about the UV-C radiation risk

A safety interlock is fitted to switch off the access doors to the lamps

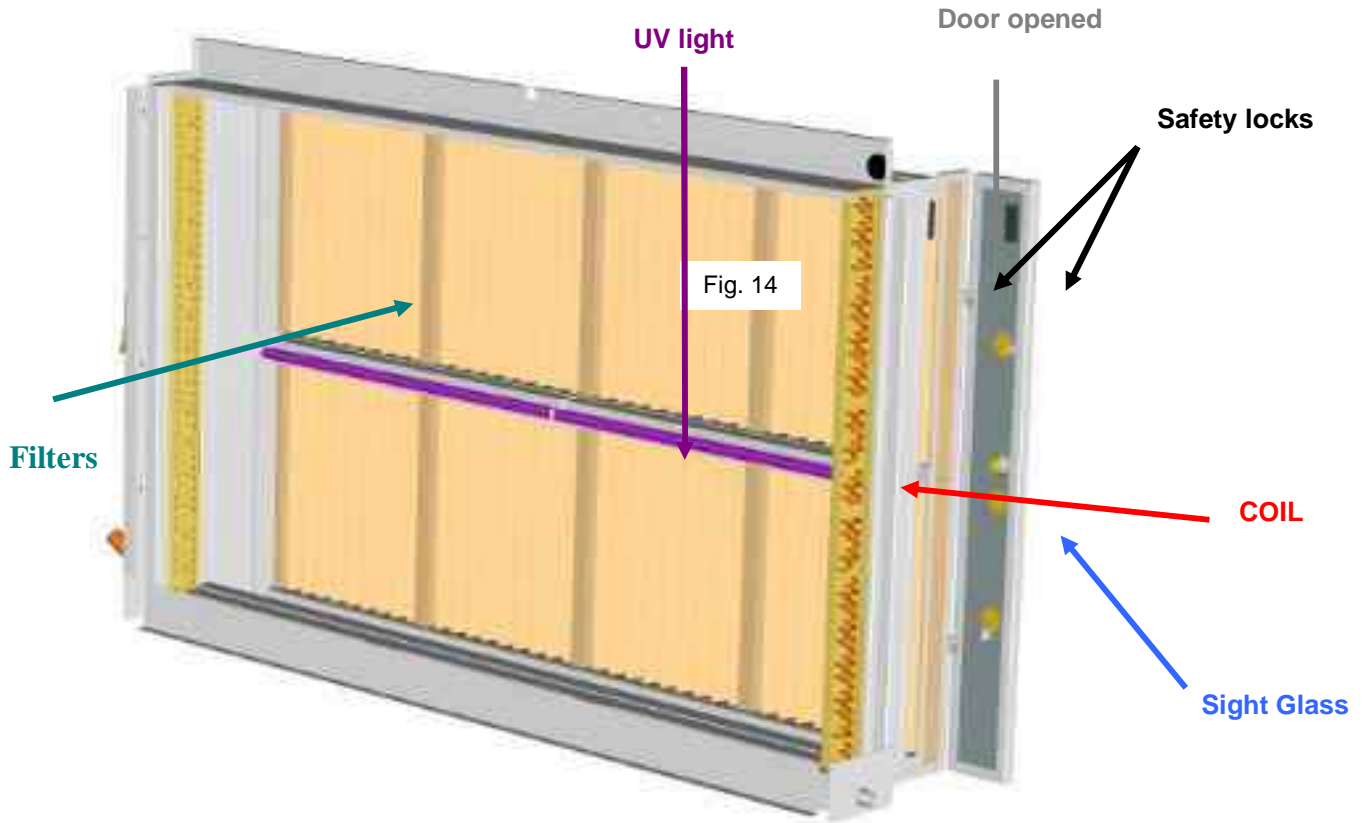

**HYDRAULIC CONNECTIONS**

Hot water coils offer fully modulating control through the use of a 3 way valve. The hot water coil, connections and valves are all tested at pressure of 15 bars. Frost protection is provided by forcing the opening the 3 way valve when supply temperature from hot water coil falls below 8°C and by stopping the outdoor fan when that supply temperature falls below 6°C. In addition to that, the 3 ways is also opened at 10% value if the outdoor temperature falls below an adjustable value. Hot water coils are always factory fitted, wired and fully tested, prior to shipment. Hot water coil includes automatic purge system.

The hot water coil is fitted with a three way proportional valve and two isolating shut off valves. Two spanners must be used to tighten the connections. One spanner must maintain the valve body when connecting the pipe-work to the main. Failure to do so may damage the pipes joints and invalidates the warranty.

- Filling up and starting the system
- Adjust the control for Heating by reducing the simulated ambient temperature down to 10°C
  - Check that the red indicators located under the valve actuator are moving correctly with the signal.

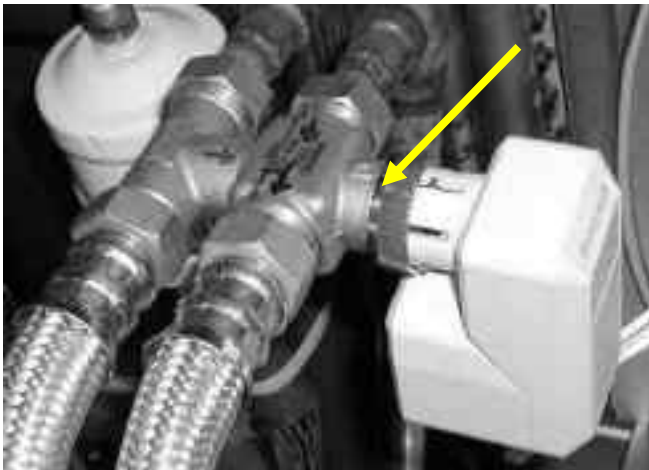

- Fill the hydraulic system and bleed the coil using the air vents. Check incoming hot water.
- Check the various connections for possible leaks

**FREEZE PROTECTION**

- 1) Glycol for freeze protection. Check the hydraulic system contains Glycol for protection against freezing.

**GLYCOL IS THE ONLY EFFECTIVE PROTECTION AGAINST FREEZING**

The antifreeze must protect the unit and avoid icing under winter conditions.  
**WARNING:** Mono-ethylene glycol based fluids may produce corrosive agents when mixed with air.

- 2) Drain the installation. You must ensure that the manual or automatic air bleeders have been installed on all high points in the system. In order to drain the system, check that all the drain cocks have been installed on all low points of the system.

**HOT WATER COILS FROZEN DUE TO LOW AMBIENT CONDITIONS ARE NOT COVERED BY THE WARRANTY.**

**ELECTROLYTIC CORROSION**  
 Attention is drawn to the corrosion problems resulting from electrolytic reaction created by unbalanced earth connections.

**ANY COIL DAMMAGED BY ELECTROLYTIC CORROSION IS NOT COVERED BY THE WARRANTY**





**Connection HWC F-G-H box**

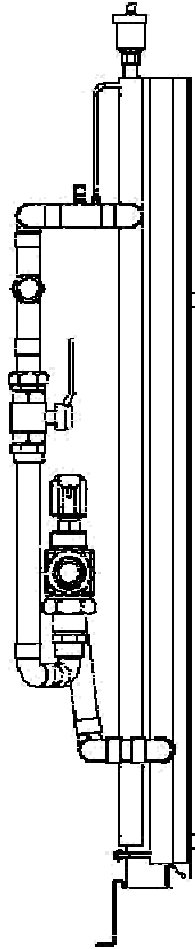

**Pipe Internal Diameters (DN)**

	F085	F100	F120	F150	F170	F200	F230
S	25	25	25	32	32	32	32
H	32	32	32	40	40	40	40

**MAXIMUM WORKING PRESSURE: 8 BARS**  
**MAXIMUM WORKING TEMPERATURE: 110°C**

**GENERAL INFORMATIONS**

The electric heater comprises of shielded resistance heaters, which are smooth stainless steel tubes 6 W/cm<sup>2</sup> capacity. High temperature limit control offers overload protection and is set to 90°C and located at less than 150mm after electric heaters. This is provided as a standard feature on the electric heater, with the electric power supply cables made of reticulated silicon rubber, resistant to temperatures up to 200°C. For any rooftop unit size, three sizes of electric heater are available, S (standard), M (Medium) and H (high).

**FLEXY 2 85, 100 and 120 have:**

Standard heat: 30 kW, 2 stages  
 Medium Heat: 54 kW, Fully modulating (Triac)  
 High Heat: 72 kW, Fully modulating (Triac)

**FLEXY 2 150 and 170 have:**

Standard heat: 45 kW, 2 stages  
 Medium Heat: 72 kW, Fully modulating (Triac)  
 High Heat: 108 kW, Fully modulating (Triac)

**FLEXY 2 150 and 170 have:**

Standard heat: 72 kW, 2 stages  
 Medium Heat: 108 kW, Fully modulating (Triac)  
 High Heat: 162 kW, Fully modulating (Triac)

Capacity of the medium and high heat heater can be limited electronically to an exact value through the CLIMATIC™ 50. To reduce installation time and hence cost, electric heaters are always factory fitted, fully wired and tested, prior to shipment.

Module size (kW)	380V		400V		415V	
	Current (A)	Cap (kW)	Current (A)	Cap (kW)	Current (A)	Cap (kW)
30	40.7	26.8	42.5	29.5	44.5	32.0
45	61.1	40.5	63.8	44.3	66.8	48
54	73.4	48.4	76.6	52.9	80	57.7
72	55.1	36.2	57.5	39.8	60.0	43.1
108	146.8	96.8	153.2	105.8	160	115.4
162	220.2	145.2	229.8	158.7	240	173.1

**PRELIMINARY CHECKS BEFORE START-UP**

**NOTE :**

ANY WORK ON THE GAS SYSTEM MUST BE CARRIED OUT BY QUALIFIED PERSONNEL. THIS UNIT MUST BE INSTALLED IN ACCORDANCE WITH LOCAL SAFETY CODES AND REGULATIONS AND CAN ONLY BE USED IN PLANNED INSTALLATION CONDITIONS FOR OUTDOOR. PLEASE READ CAREFULLY THE MANUFACTURER'S INSTRUCTIONS BEFORE STARTING A UNIT. BEFORE COMMISSIONING A UNIT WITH GAS BURNER, IT IS MANDATORY TO ENSURE THAT THE GAS DISTRIBUTION SYSTEM (type of gas, available pressure...) IS COMPATIBLE WITH THE ADJUSTMENT AND SETTINGS OF THE UNIT.

**CHECK ACCESS AND CLEARANCE AROUND THE UNIT**

- Make sure one can move freely around the unit.
- A minimum one-meter clearance must be left in front of the burnt gas exhaust flue.
- Combustion air inlet and burnt gas exhaust(s) must NOT be obstructed in any way.

**SUPPLY NETWORK PIPE SIZING**

**MALE THREADED CONNECTION FOR GAZ BURNER: 3/4"**

Check that the gas supply line can provide the burners with the pressure and the gas flow rate necessary to provide the heating nominal output.

**Number of male threaded connections (3/4")**

UNIT SIZE	85	100	120	150	170	200	230
S POWER	1	1	1	2	2	2	2
H POWER	2	2	2	2	2	2	2

**GAS FLOW (for G20 at 20mbar and 15°C) m<sup>3</sup>/h**

UNIT SIZE	85	100	120	150	170	200	230
S POWER	6.3	6.3	6.3	12.5	12.5	18.8	18.8
H POWER	12.5	12.5	12.5	18.8	18.8	25	25

- For modulating gas we have just H power for F, G & H-box
- The gas supply of a Rooftop gas unit must be realized according to Sound Engineering Practice and the local safety codes and rules.
  - In any case the diameter of pipe-work connected to each Rooftop must not be smaller than the diameter of the connection on the Rooftop unit.
  - Make sure that a shut-off isolation valve has been installed before EACH Rooftop.
  - Check the supply voltage to the exit of the power supply's transformer T3 of the burner: it must be between 220 and 240V.

**STARTING UP THE GAS BURNER**



- Purge the pipe-work near the connection on the ignition control Valve for a few seconds.
- Check that the unit's treatment "Fan" blower is running.
  - Set the control to "ON" This will priorities the gas burner.
  - Increase the set temperature (room set point temperature) to a temperature higher than the actual room temperature.

Table4 - Standard start-up Chronology

Time in seconds	1	2	3	4	5	6	7	8	9	10	11	29	30	31	32	33	34	35	36	37	38	39	40	41	42	43	44	45	46	398	399	400	401
Operations																																	
Control operation sequence																																	
Extraction fan																																	
Smoke extraction fan "ON"																																	
30 to 45 seconds pre-ventilation																																	
Fire-up spark electrode 4s																																	
Opening of the gas valve "High Heat"																																	
Flame propagation towards the ionisation probe																																	
If ionisation within 5s: Normal running																																	
Otherwise fault on gas ignition control block																																	
After 5minutes, fault reported on the climatic controller																																	

If incorrect sequence refer to the fault analysis table to identify the problem

**PRESSURE ADJUSTMENTS ON HONEYWELL PRESSURE REGULATING VALVE TYPE VK 4125 P**

Pressure regulator adjustment with 300mbar gas supply:



- The Burner must run in High Heat mode for this check.
- Place the tube of the "accurate" manometer on the Inlet pressure port (Figure 15) of the Gas Regulating Valve after having loosened the screw by one turn

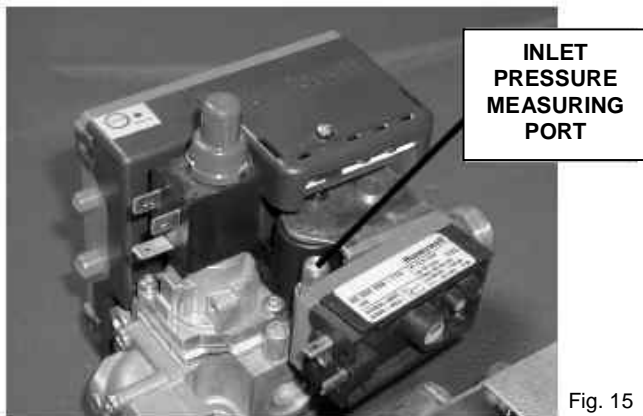

Fig. 15

Check and adjust if necessary the valve Inlet pressure to 20.0mbar (G20) or 25.0mbar for Groningen (G25) or 37.0mbar for propane (G31) after gas burner ignition (fig.16)



Fig.16

**High Heat Injection Pressure Checks**

Check and adjust if necessary the valve OUTLET pressure to 10.4mbar (G 20) / 13.1mbar for Groningen (G25) & 34.3 mbar for propane (G31) (fig.17)



The out pressure must be measured on the pressure tap located on the gas injector support bar to avoid the pressure drop due to the elbow after the valve



Fig. 17

**Low Heat Injection Pressure Checks**

- Switch the control to Low Heat
- Check and adjust if necessary the Outlet pressure to 3.7 mbar (G20) or 5.1 mbar for Groningue(G25) & **15.3 mbar** for propane (G31)(fig.18)

- After the adjustment of the low heat, re-verify the high heat
- re-position the stoppers and close the pressure ports.

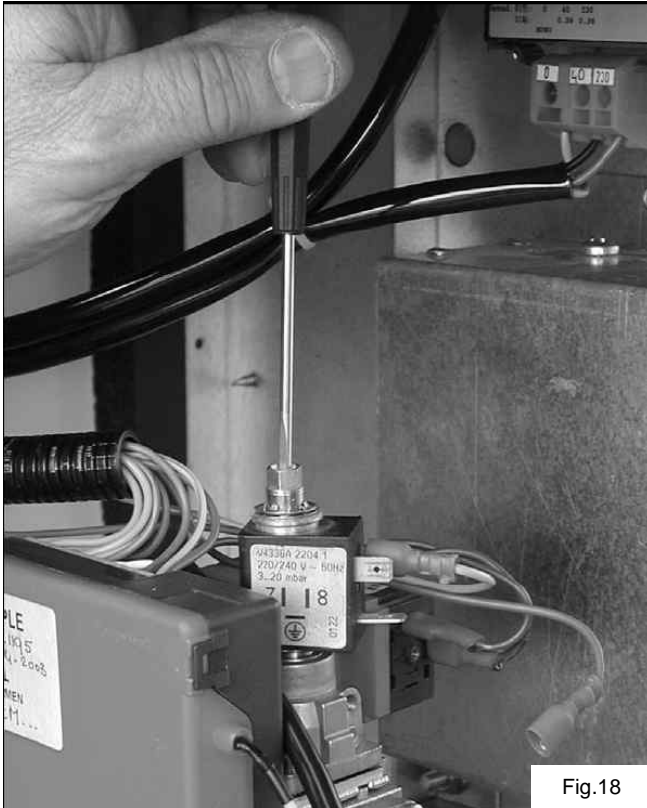

Fig.18

Pressure adjustments table for each type of gas (mbar)

Category	Supply pressure	Low Heat Injection min.	High Heat Injection
G20	20.0 +/- 1	3.7 +/- 0.1	10.4 +/- 0.2
G25 (Groningue)	25.0 +/- 1.3	5.1 +/- 0.1	13.1 +/- 0.2
G31 (GPL)	37.0 +/- 1.9	<b>15.3 +/- 0.3</b>	34.3 +/- 0.6



**PRESSURE ADJUSTMENTS ON HONEYWELL PRESSURE REGULATING VALVE TYPE VR 4605P**

Pressure regulator adjustment with 300mbar gas supply:



- The Burner must run in High Heat mode for this check.
- Place the tube of the “accurate” manometer on the Inlet pressure port (Figure 19) of the Gas Regulating Valve after having loosened the screw by one turn

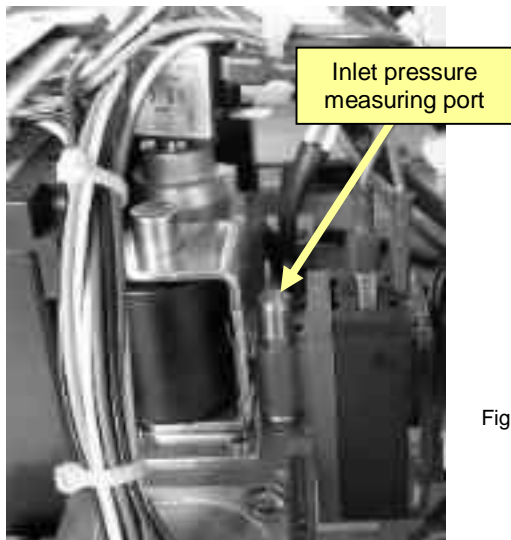

Fig. 19

Check and adjust if necessary the valve Inlet pressure to 20.0mbar (G20) or 25.0mbar for Groningen (G25) or 37.0mbar for propane (G31) after gas burner ignition (fig.20)



Fig.20

**High Heat Injection Pressure Checks**

Check and adjust if necessary the valve OUTLET pressure to 8.0mbar (G 20) / 10.4mbar for Groningen (G25) & **28.3** mbar for propane (G31) (fig.21)



Fig. 21

The out pressure must be measured on the pressure tap located on the gas injector support bar to avoid the pressure drop due to the elbow after the valve



**Low Heat Injection Pressure Checks**

- Switch the control to Low Heat
- Check and adjust if necessary the Outlet pressure to 3.1 mbar (G20) or 3.9 mbar for Groningen (G25) & **12.6 mbar** for propane (G31) (fig.22)

- After the adjustment of the low heat, re-verify the high heat
- re-position the stoppers and close the pressure ports.



Fig.22

Pressure adjustments table for each type of gas (mbar)

Category	Supply pressure	Low Heat Injection min.	High Heat Injection
G20	20.0 +/- 1	3.1 +/- 0.1	8 +/- 0.2
G25 (Groningue)	25.0 +/- 1.3	3.9 +/- 0.1	10.4 +/- 0.2
G31 (GPL)	37.0 +/- 1.9	<b>12.6 +/- 0.3</b>	<b>28.3 +/- 0.6</b>



**BURNER SAFETY CHECKS****Smoke extractor pressure switch Test.**

- With the gas burner running, disconnect the flexible tube fitted to the pressure tapping on the pressure switch (Fig. 23).
- The Flame must disappear and the extraction fan must carry on running.
- However, NO fault will be displayed (Gas ignition control block or CLIMATIC).

Fig. 23



- After reconnecting of the tube, the Burner will restart after a period of 30 to 45 seconds pre-ventilation.

**Gas pressure switch test**

- With the gas burner running, close the shut off valve located before the rooftop. (fig. 24)

Fig. 24



- The burner stops completely.
- However, No fault light will be displayed on the Gas ignition control block. After 6 Minutes, the CLIMATIC will display a fault.
- Reset the CLIMATIC.

**Ionisation Probe test**

- With the gas burner running, disconnect the terminal plug coming from the ionisation probe to the gas ignition control box.



- The flame disappears
- The fan is still running and attempting to restart the burner (restart cycle 30 to 45 seconds).
- if the ignition probe is not reconnected at the end of the ignition sequence the burner will stop completely.
- The fault light on the gas ignition control block is ON.
- Manually reset the gas ignition control block to eliminate the fault

IN CASE OF PROBLEMS REFER TO THE START UP SEQUENCE FLOWCHART NEXT PAGE



GAS BURNER FIRE-UP SEQUENCE

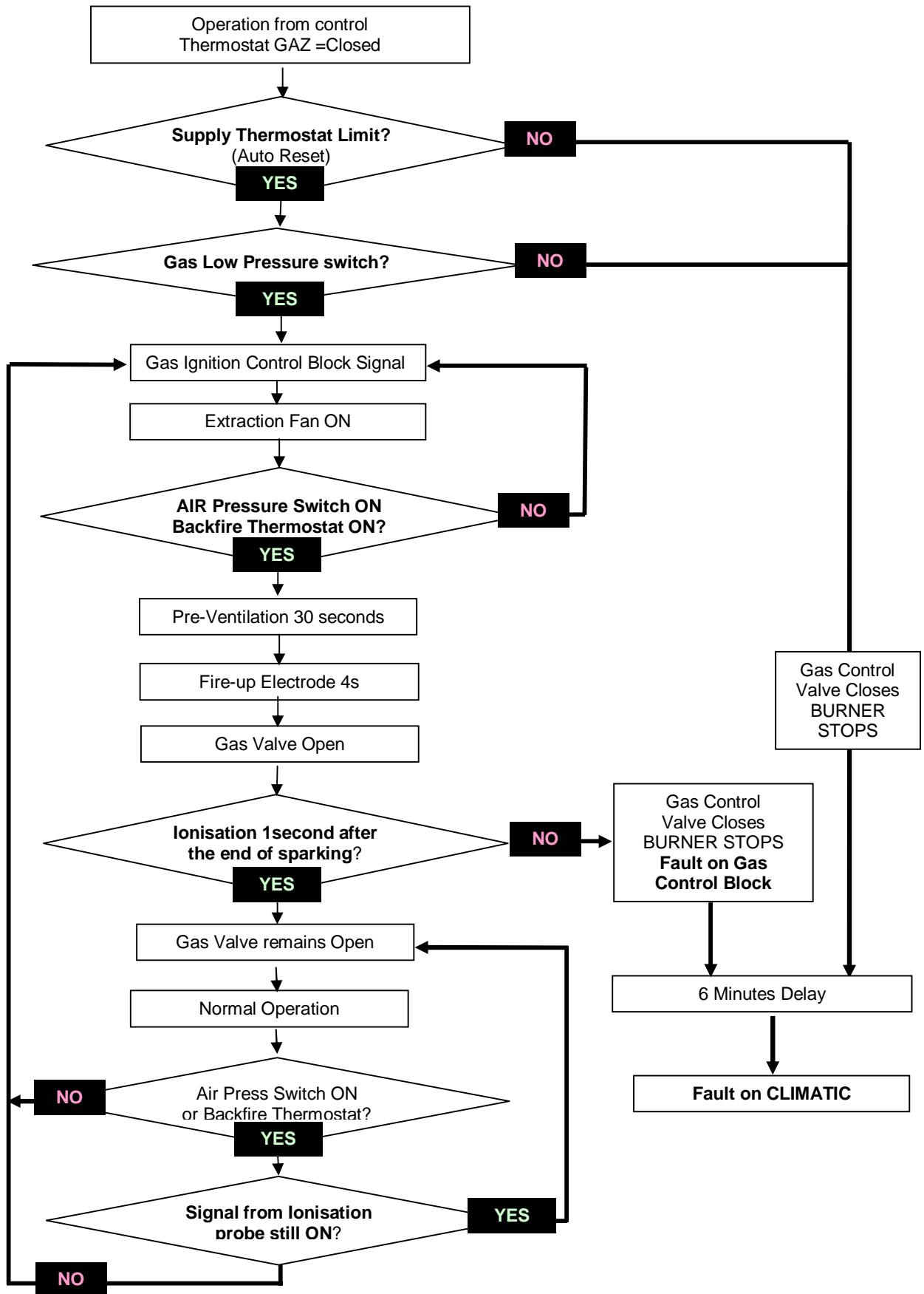

GAS BURNER TROUBLESHOOTING

If faults reported on CLIMATIC

- Reset the CLIMATIC.
- Check voltage: 230V after circuit breaker.
- Check GAS isolation shut-off valves are open.
- Check GAS pressure at the inlet of the GAS valves. It must be >20 mbar when the Burners shut down.

-Adjust the set points to priorities the burner. Increase the value of the room temperature set point to a temperature higher than actual room temperature.

DIAGNOSTIC TABLE BALTIC GAS BURNER				
STAGE	NORMAL OPERATION	POSSIBLE FAULT	ACTION	POSSIBLE SOLUTION
Heating Requested	Extraction fans start	Fault on the blower thermostat	+ Check connections on the blower thermostat.	+ Replace thermostat
		Lack of gas supply	+ Check valve's opening & supply pressure	+ Restore gas supply
		Fault on the superheat thermostat on the gas burner support bar	+ Check superheat thermostat's operation after manual reset	+ Replace superheat thermostat
Starting of the extraction fans	Extraction Fans are running	After 10 seconds safety shutdown by the ignition control block	+ Check connections of the control block on the gas valve	+ Repositioning of the control block on the valve + Replace valve
		Nothing happens	+ Check the free movement of the fan wheel + Check Electrical connection on the Gas Ignition Control Block and on EF connection Board + Check the Fan supply voltage	+ Replace fan + Replace EF connection board If necessary
Extraction Fan is ON	After 30 to 45 seconds: prevention the fire-up electrode should spark.	Continuous Ventilation without sparks from fire-up electrode	+ Check the fire-up electrode + Check the pressure drop at the pressure switch: It must be higher than 165 Pa +Check the good operation of the pressure switch using an Ohmmeter and by artificially creating a depression in the tube.	+ Re-position the pressure switch tube. + Change the pressure switch.
Continuous ventilation and sparks from fire up electrode.	After a few seconds the gas burner fires-up	After 4 seconds the GAS Burner still not operating and safety shutdown by the Ignition Control Block.	+ Check injection pressure during start-up (Value for High Heat) +Remove the control box from the gas block.	+ Remove the air from the Gas pipe-work + Adjust the injection pressure to high heat value. + Change the Control Box if the Gas valve is OK.
		Within 4 seconds the gas Burner fires-up BUT safety shutdown from the Ignition Control Block.	+ Check the Position and connection of the Ionisation Probe. It must not be Earthed (230V). + Measure the Ionisation Current: It must be higher than 1.5 microAmps. + Check the Type of GAS.	+Check the whole electrical supply. + Adjust the supply and injection pressure if gas is different from natural gas G20 :( G25 Gas of Groningue for example).

**DISASSEMBLING THE GAS BURNER FOR MAINTENANCE PURPOSES**

**Preliminary Safety Recommendations**

- Isolate the unit using the main isolator switch.
- Close off the isolating gas valve located before the unit.
- Disconnect the Pipe-work. Do not discard the seals.



**Disassembling the gas «burner support bar»**

- Disconnect the Electrical Connector on the electric connection board EF47
- Remove the two screws which hold the gas Bar in Place
- Carefully remove the gas « burner support bar » avoiding any damages to the electrodes.

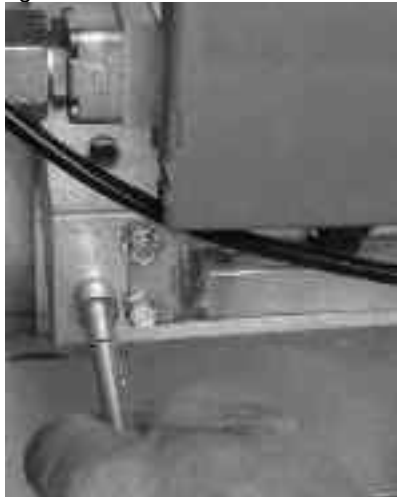

**Disassembling the flue**

- Electrically disconnect the fan and remove the screws holding it in place.
- Take care not to loose any cage nuts in the smoke box.

ATTENTION: Check the correct position of the pressure tube used by the extraction pressure switch.

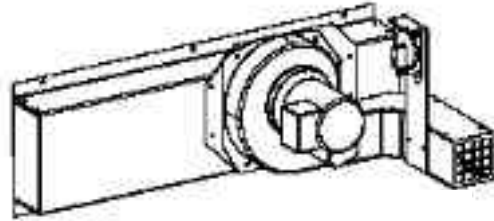

**Required Equipment List for maintenance Adjustment and Start-up**

- An accurate manometer from 0 to 3500 Pa (0 to 350 mbar): 0.1% full scale.
- A Multimeter with Ohmmeter and Micro-amps scale
- An Adjustable Spanner
- Tube Spanner Set: 5, 7, 8, 9, 10, and 13.
- Flat spanner: 5, 7, 8 & 9
- Flat Screwdrivers diameter 3 and 4, Phillips n°1
- Vacuum cleaner
- Paint brush



**GAS BURNER SUPPORT BAR**

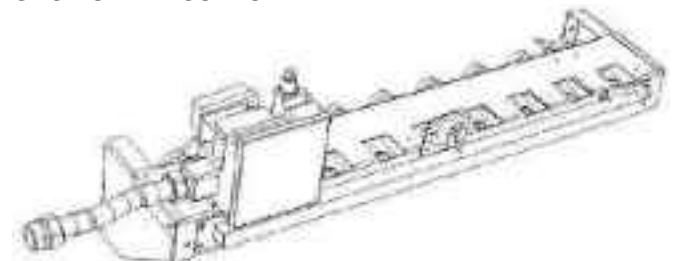

60kW

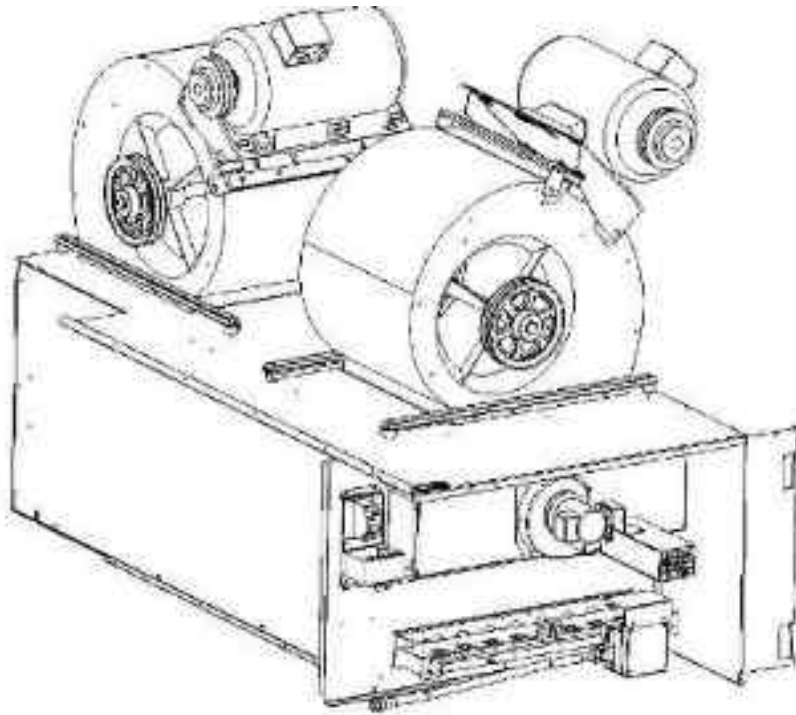

120kW

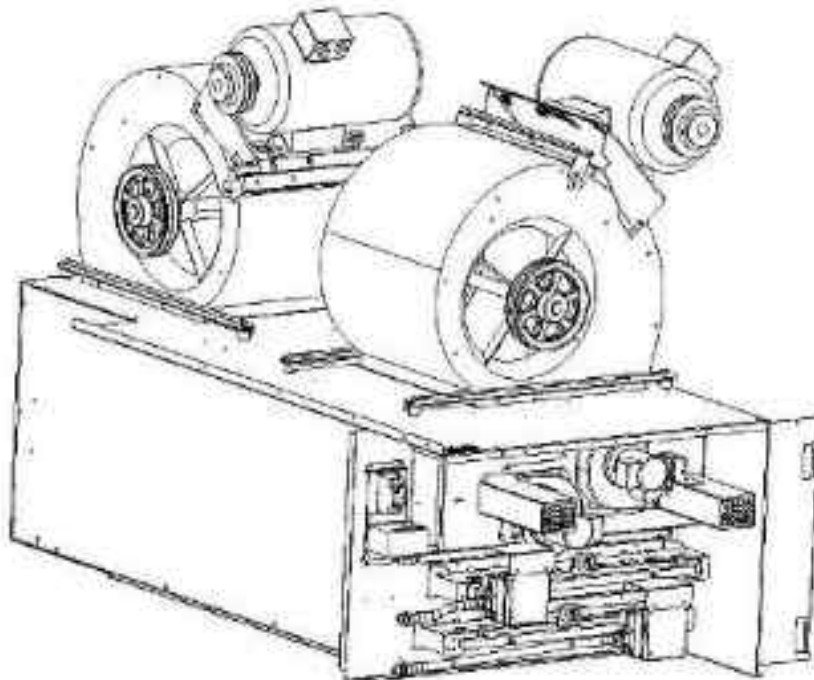

180kW

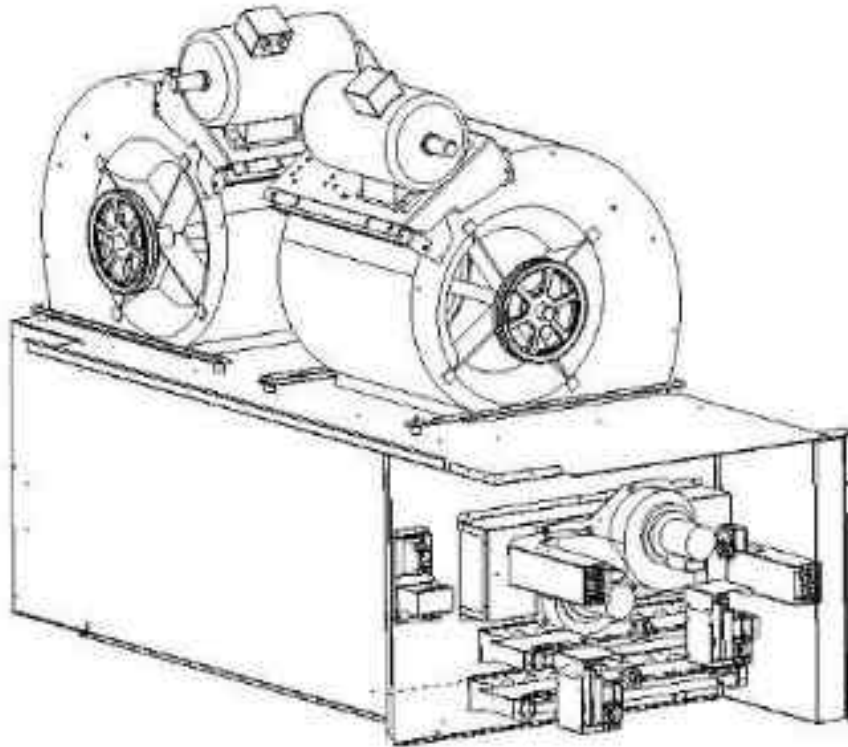

240kW

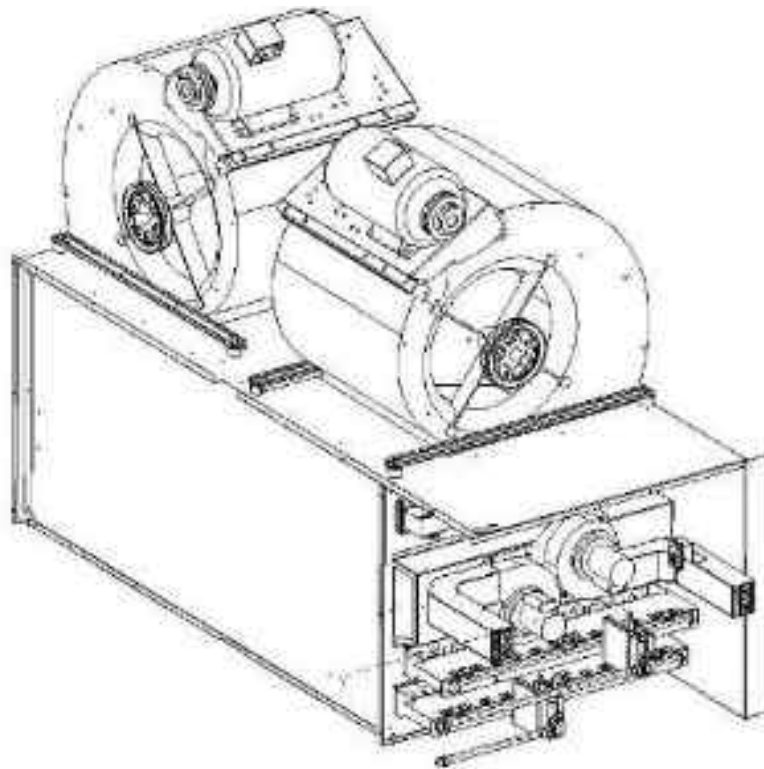

**MODULATING GAS (UNDER PATENT INPI May 2004)**

**The actuator**

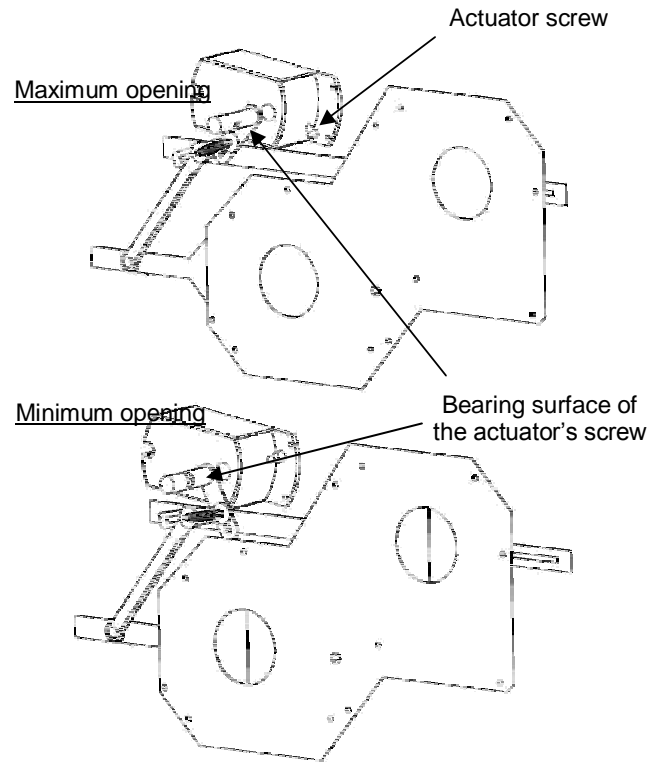

The actuator receives an information 0-10V from the regulation for the positioning of the air shutter; then the actuator transmits its position to the printed-board which will order the valve.

**STARTING UP THE GAS BURNER**

Purge the pipe-work near the connection on the ignition control Valve for a few seconds.

**Check position and operation of the actuator**

Disengaging for hand drive operation



Manual rotation of the actuator



- Check that the unit's Treatment Fan Blower is running.
- Set the control to "ON" This will priorities the gas burner.
- Increase the set temperature (room set point temperature) to a temperature higher than the actual room temperature.

The start of the gas burner must be done at **high heat injection**.

**PRESSURE ADJUSTMENTS ON HONEYWELL PRESSURE REGULATING VALVE VK4105MB AND ON ELECTRONIC BOARD W4115D1024**

**Pressure regulator adjustment with 300mbars gas supply:**



- The Burner must run in High Heat mode for this check.
- Place the tube of the "accurate" manometer on the Inlet pressure port (Figure 25) of the Gas Regulating Valve after having loosened the screw by one turn

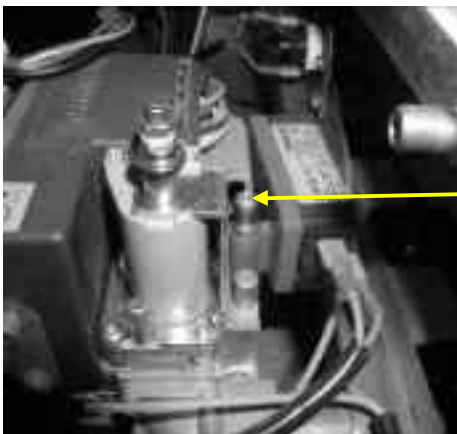

**Inlet pressure measuring port**

Fig. 25

Check and adjust if necessary the valve Inlet pressure to 20.0mbar (G20) or 25.0mbar for Groningen (G25) after gas burner ignition (fig.26)

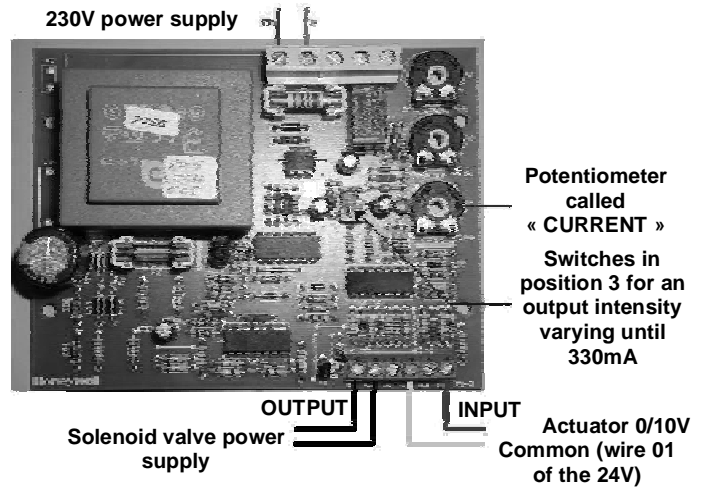

Fig. 26

**High & Low heat injection pressure check:**

*Electronic board W4115D1024*

There is one board for two valves



*Regulating valve VK4105MB*

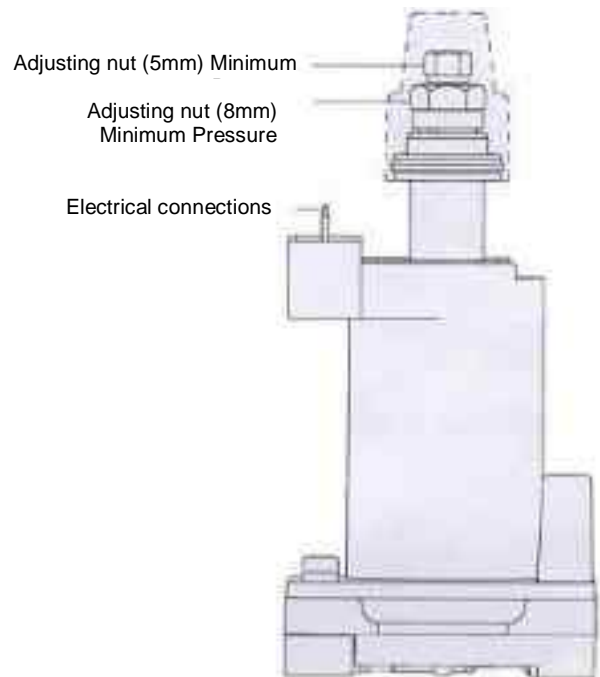

- Check the 230V supply voltage of electronic board: the phase on terminal 01 and the neutral conductor on terminal 02

- Check the wiring of the signal 0-10V between terminal 64 (polarity 01 of the 24V) and terminal 66 (+ coming from the actuator)

- Check the connection of the modulating solenoid valve between the electronic board's terminals 61 & 62

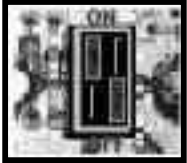

- Select the operating mode n°3 "output 0-330mA":
  - Switch n°1 → ON
  - Switch n°2 → OFF

**High heat:**



- Place the potentiometer called "current" on position Max.

- Apply 9V to the climatic output; the actuator and the gas valve position themselves in full opening and the burner starts.

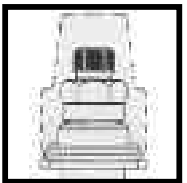

- Regulate the value of the maximum flow at 10.4mbar (for natural gas and at approximately 13.1mbar for Groningen gas) by operating on the adjusting nut called "maximum pressure".

**Low heat:**



- Place the potentiometer called "current" on position Min

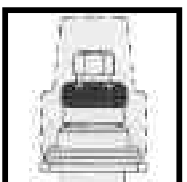

- Regulate the value of the minimum flow at **2 mbar (for natural gas and at approximately 2.6 mbar for Groningen gas)** by operating on the adjusting nut called "minimum pressure".



- Bring back the potentiometer towards the position + until obtaining the desired 10.4mbar in high heat for natural gas.

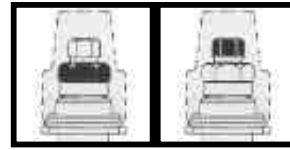

- Check the pressure values for high and low heat using the climatic output and refine the adjustments thanks to the nuts of the solenoid valve.

- Check that by applying 10V to the climatic output, we do not exceed the maximum pressure (10.4mbar for natural gas).

- Ditto, by disconnecting the power supply of the solenoid valve, check that the pressure is the same one as the minimum pressure regulated previously.

- Check the good reaction of the Honeywell board's regulation by applying 7V to its input; it must already act on the position of the actuator and on the gas flow, which must have a value lower than the max flow ones.



**MODULATING GAS (UNDER PATENT INPI May 2004)**

**The actuator**

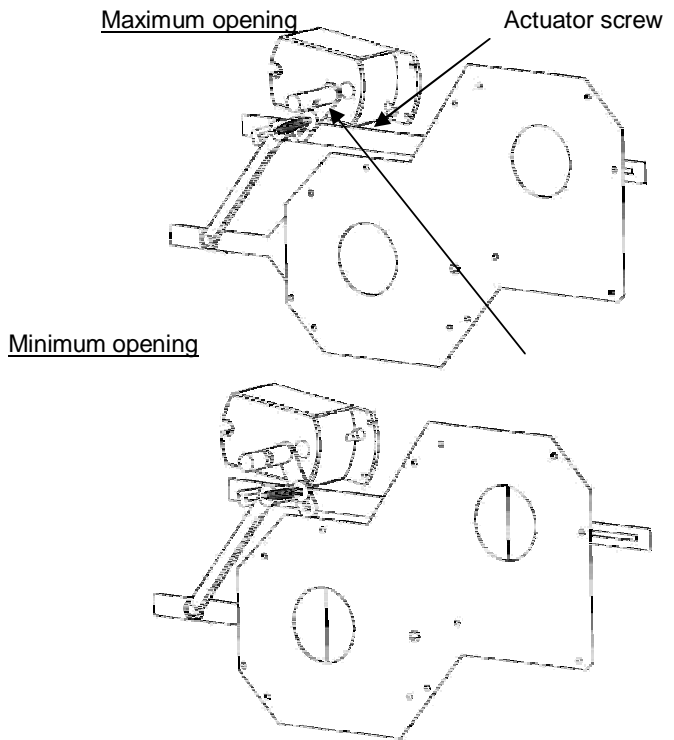

The actuator receives an information 0-10V from the regulation for the positioning of the air shutter; then the actuator transmits its position to the printed-board which will order the valve.

**STARTING UP THE GAS BURNER**

Purge the pipe-work near the connection on the ignition control Valve for a few seconds.

**Check position and operation of the actuator**

Disengaging for hand drive operation



Manual rotation of the actuator



- Check that the unit's Treatment Fan Blower is running.
- Set the control to "ON" This will priorities the gas burner.
- Increase the set temperature (room set point temperature) to a temperature higher than the actual room temperature.

The start of the gas burner must be done at **high heat injection**.

**PRESSURE ADJUSTMENTS ON HONEYWELL PRESSURE REGULATING VALVE VR4605MB AND ON ELECTRONIC BOARD W4115D1024**

**Pressure regulator adjustment with 300mbars gas supply:**



- The Burner must run in High Heat mode for this check.
- Place the tube of the "accurate" manometer on the Inlet pressure port (Figure 27) of the Gas Regulating Valve after having loosened the screw by one turn

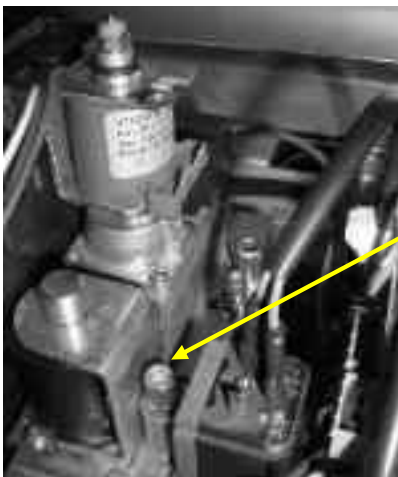

Inlet pressure measuring port

Fig. 27

Check and adjust if necessary the valve Inlet pressure to 20.0mbar (G20) or 25.0mbar for Groningen (G25) after gas burner ignition (fig.28)

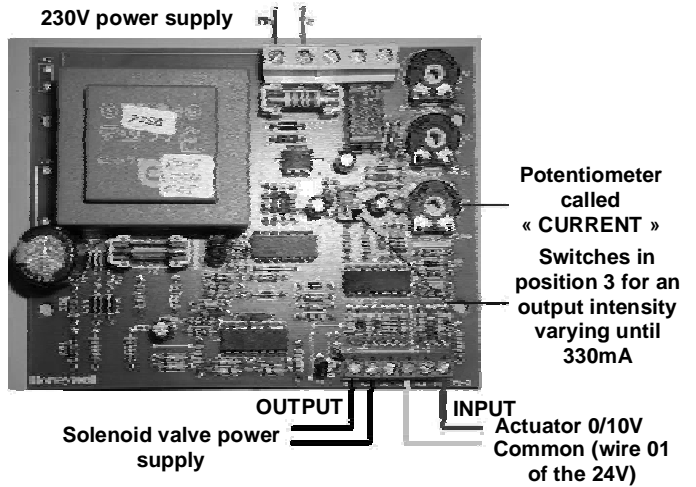

Fig. 28

**High & Low heat injection pressure check:**

*Electronic board W4115D1024*

There is one board per valve



*Regulating valve VK4605MB*

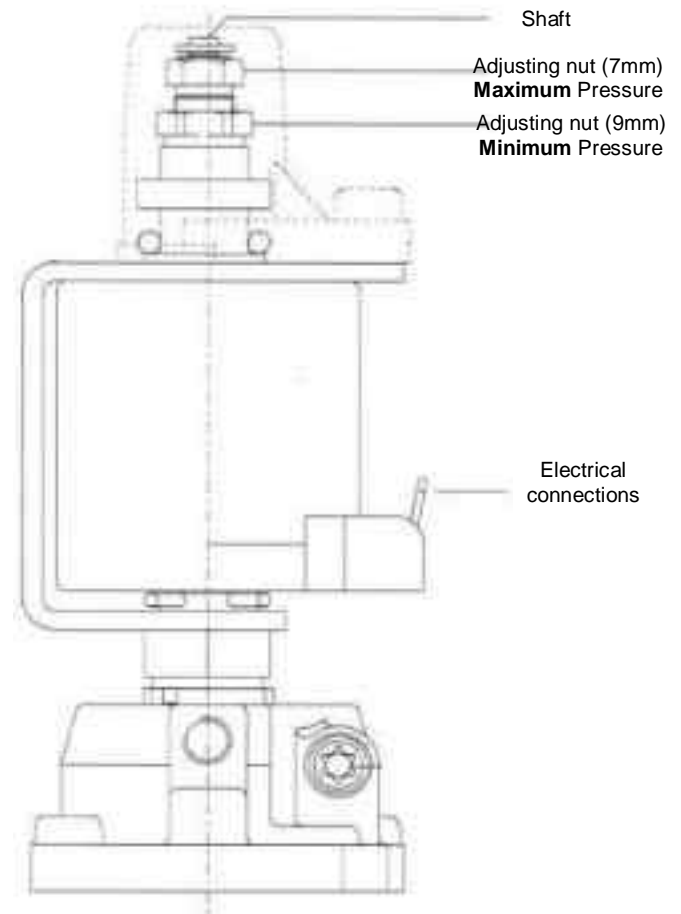

- Check the 230V supply voltage of electronic boards: the phase on terminal 01 and the neutral conductor on terminal 02

- Check the wiring of the signal 0-10V between terminal 64 (polarity 01 of the 24V) and terminal 66 (+ coming from the actuator)

- Check the connection of the modulating solenoid valve between the electronic board's terminals 61 & 62

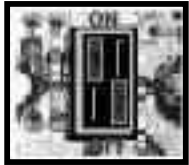

- Select the operating mode n°3 "output 0-330mA":

- Switch n°1 → ON
- Switch n°2 → OFF

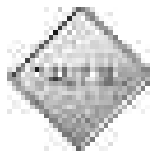

The minimum pressure setting must first be adjusted to ensure that burner will safety light up, then maximum pressure setting can be adjusted. Any adjustment of the minimum pressure influences the maximum pressure setting. Any adjustment must be done with flat spanners.

**Adjustment of the W4115D1024 board's potentiometer:**

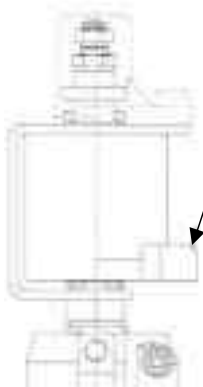

- Connect the Multimeter with Micro-Amps scale in serial with the MODUREG.

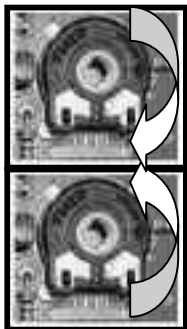

- To prevent hysteresis, place the potentiometer called "current" on position Min.

- Increase the current by turning this the desired

potentiometer, until maximum current is obtained: here, to reach 8.0mbar, we must apply 105mA, according to the curve below.

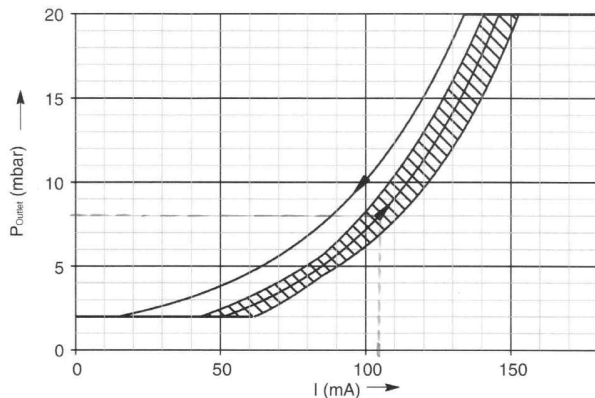

**Adjusting minimum pressure setting:**

- Disconnect electrical connection to MODUREG (=modulating solenoid valve)

- Regulate the value of the minimum flow at 2.2mbar (for natural gas and at 3.0 mbar for Groningen gas) by turning the adjusting nut "Maximum pressure".



**Adjusting maximum pressure setting:**

- By Pushing the shaft gently downwards to the maximum adjustment screw, you'll see an approximate value of the maximum pressure

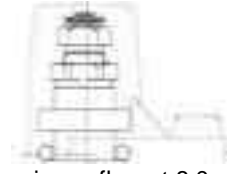

- Reconnect the electrical connection to MODUREG

- Regulate the value of the maximum flow at 8.0mbar (for natural gas and at 10.4mbar for Groningen gas) by turning the potentiometer called "current", until the desired maximum pressure.

When maximum and minimum pressures are set wire the valve in the circuit.

- Now, check the good reaction of the assembly, MODUREG + electronic board, by applying 2 V to its input (=climatic 50 output); it must reach the minimum pressure (2.2mbar for natural gas)

60kW

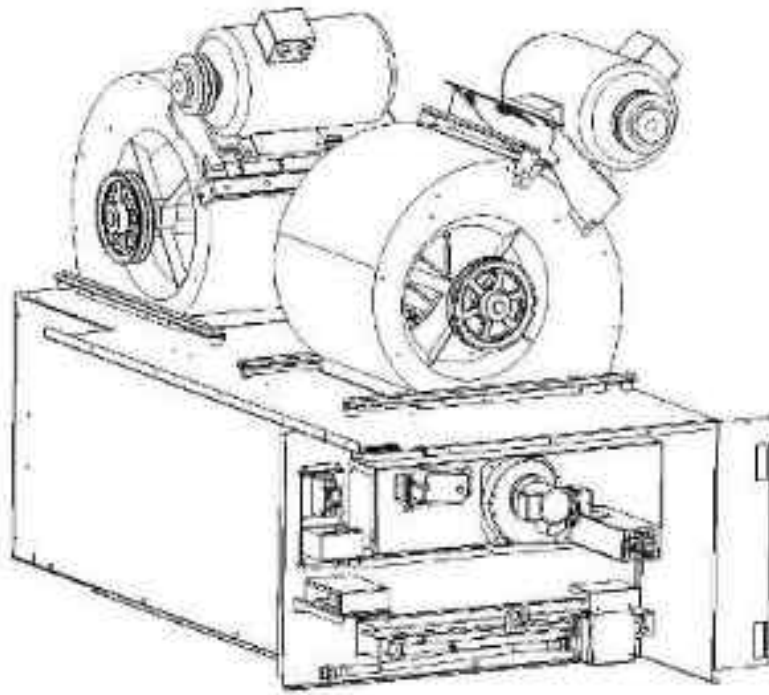

120kW

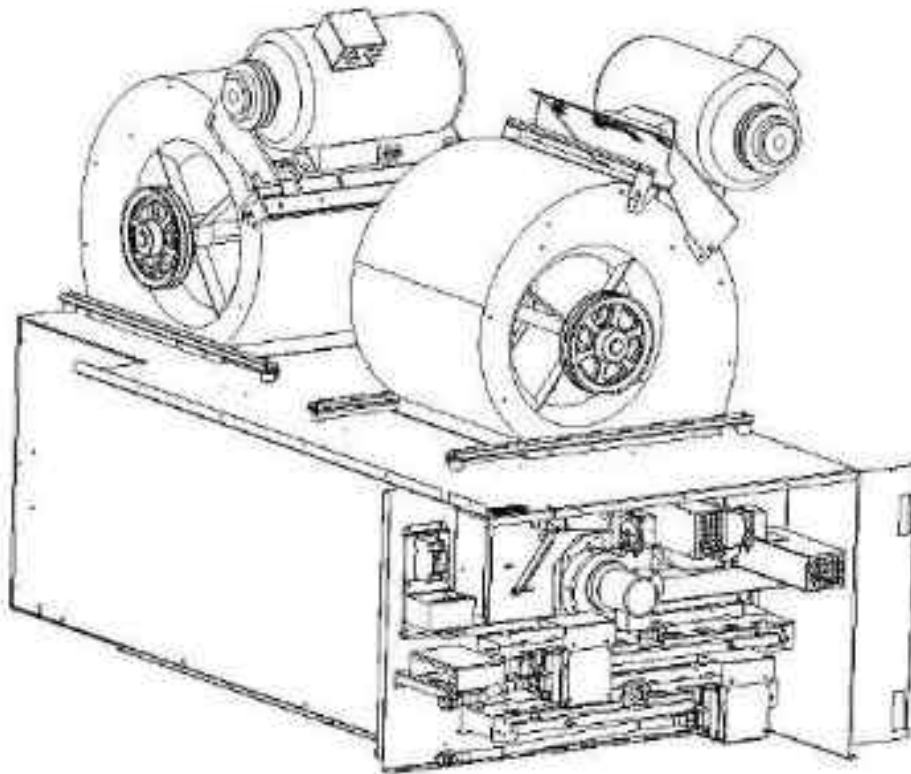

**180kW**

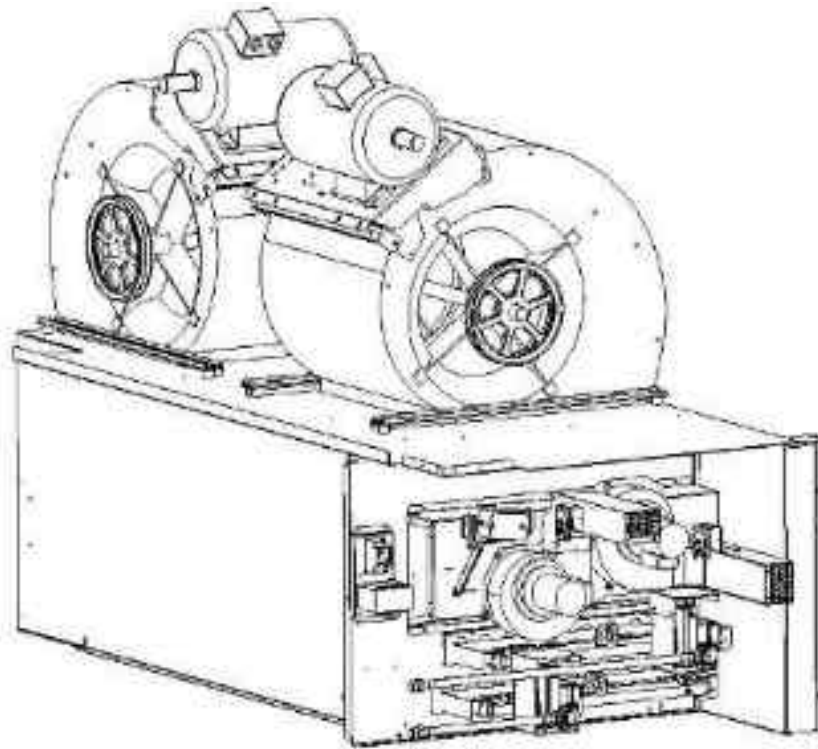

**240kW**

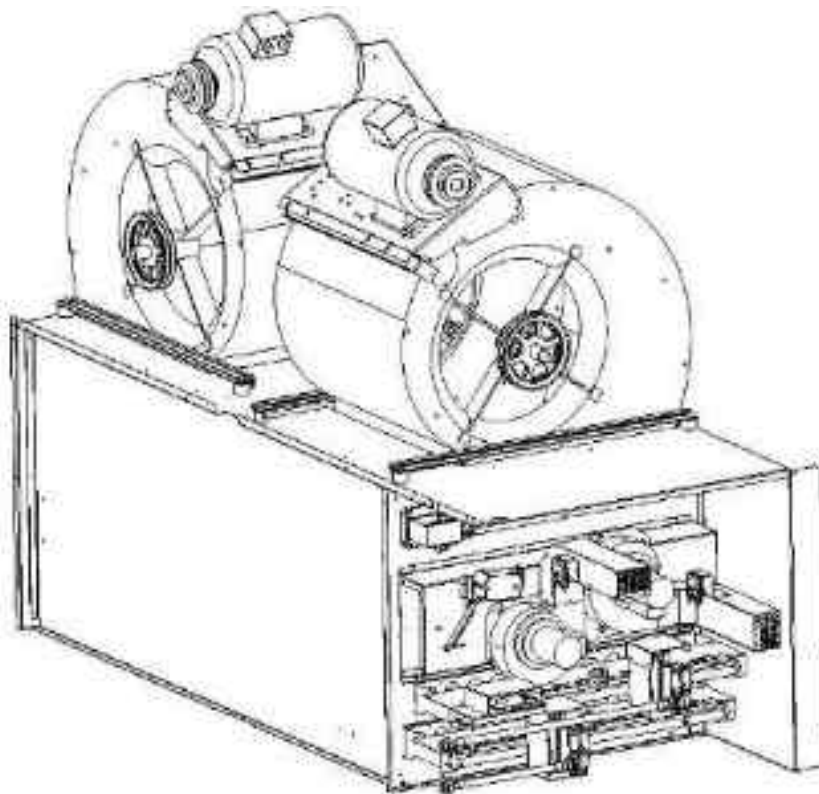

FCM*	FHM*	FGM*	FDM*
01	01 HEAT PUMP	01	01 HEAT PUMP
02 ELECTRIC HEATER (Standard heat) 2 steps (*)	02 ELECTRIC HEATER (Standard heat) 2 steps (*)	02	02
03 ELECTRIC HEATER (Medium heat) modulating (*)	03 ELECTRIC HEATER (Medium heat) modulating (*)	03	03
04 ELECTRIC HEATER (High heat) modulating (*)	04 ELECTRIC HEATER (High heat) modulating (*)	04	04
05 HOT WATER COIL (Standard / High heat) (*)	05 HOT WATER COIL (Standard / High heat) (*)	05	05
06	06	06 GAS BURNER S(*)	06 GAS BURNER S(*)
07	07	07 GAS BURNER H (*)	07 GAS BURNER H (*)
08	08	08 MODULATING GAS BURNER (*)	08 MODULATING GAS BURNER (*)
09 ECONOMISER	09 ECONOMISER	09 ECONOMISER	09 ECONOMISER
10 CENTRIFUGAL EXHAUST FAN	10 CENTRIFUGAL EXHAUST FAN	10 CENTRIFUGAL EXHAUST FAN	10 CENTRIFUGAL EXHAUST FAN
11 POWER EXHAUST FAN AXIAL	11 POWER EXHAUST FAN AXIAL	11 POWER EXHAUST FAN AXIAL	11 POWER EXHAUST FAN AXIAL
12 MAIN DISCONNECT SWITCH	12 MAIN DISCONNECT SWITCH	12 MAIN DISCONNECT SWITCH	12 MAIN DISCONNECT SWITCH
13 SMOKE DETECTOR	13 SMOKE DETECTOR	13 SMOKE DETECTOR	13 SMOKE DETECTOR
14 FIRESTAT	14 FIRESTAT	14 FIRESTAT	14 FIRESTAT
15 AIR SOCK CONTROL	15 AIR SOCK CONTROL	15 AIR SOCK CONTROL	15 AIR SOCK CONTROL
16 CO2 SENSOR	16 CO2 SENSOR	16 CO2 SENSOR	16 CO2 SENSOR
17 ANALOG DIRTY FILTER AND FAN PROVEN SWITCH	17 ANALOG DIRTY FILTER AND FAN PROVEN SWITCH	17 ANALOG DIRTY FILTER AND FAN PROVEN SWITCH	17 ANALOG DIRTY FILTER AND FAN PROVEN SWITCH
18 COMFORT DISPLAY DC50	18 COMFORT DISPLAY DC50	18 COMFORT DISPLAY DC50	18 COMFORT DISPLAY DC50
19 COMFORT DISPLAY WIRELESS DC50W	19 COMFORT DISPLAY WIRELESS DC50W	19 COMFORT DISPLAY WIRELESS DC50W	19 COMFORT DISPLAY WIRELESS DC50W
20 SERVICE DISPLAY DS50	20 SERVICE DISPLAY DS50	20 SERVICE DISPLAY DS50	20 SERVICE DISPLAY DS50
21 MULTIROOFTOP DISPLAY DM50	21 MULTIROOFTOP DISPLAY DM50	21 MULTIROOFTOP DISPLAY DM50	21 MULTIROOFTOP DISPLAY DM50
22 ADALINK	22 ADALINK	22 ADALINK	22 ADALINK
23 TCB	23 TCB	23 TCB	23 TCB
24 ADVANCED CONTROL PACK (ENTHALPY AND HUMIDITY CONTROL)	24 ADVANCED CONTROL PACK (ENTHALPY AND HUMIDITY CONTROL)	24 ADVANCED CONTROL PACK (ENTHALPY AND HUMIDITY CONTROL)	24 ADVANCED CONTROL PACK (ENTHALPY AND HUMIDITY CONTROL)
25 HEAT RECOVERY MODULE	25 HEAT RECOVERY MODULE	25 HEAT RECOVERY MODULE	25 HEAT RECOVERY MODULE
26 LOW AMBIENT KIT	26 LOW AMBIENT KIT	26 LOW AMBIENT KIT	26 LOW AMBIENT KIT
27 LOW NOISE	27 LOW NOISE	27 LOW NOISE	27 LOW NOISE
28 UV LIGHT	28 UV LIGHT	28 UV LIGHT	28 UV LIGHT
29 HIGH EFFICIENCY SUPPLY FAN	29 HIGH EFFICIENCY SUPPLY FAN	29 HIGH EFFICIENCY SUPPLY FAN	29 HIGH EFFICIENCY SUPPLY FAN



- FCM** = Cooling only unit
- FHM** = Heat pump unit
- FGM** = Cooling only unit with gas fired heating
- FDM** = Heat pump unit with gas fired heating

**MAIN CURRENT DIAGRAM TRI / 400V / 50Hz + T**

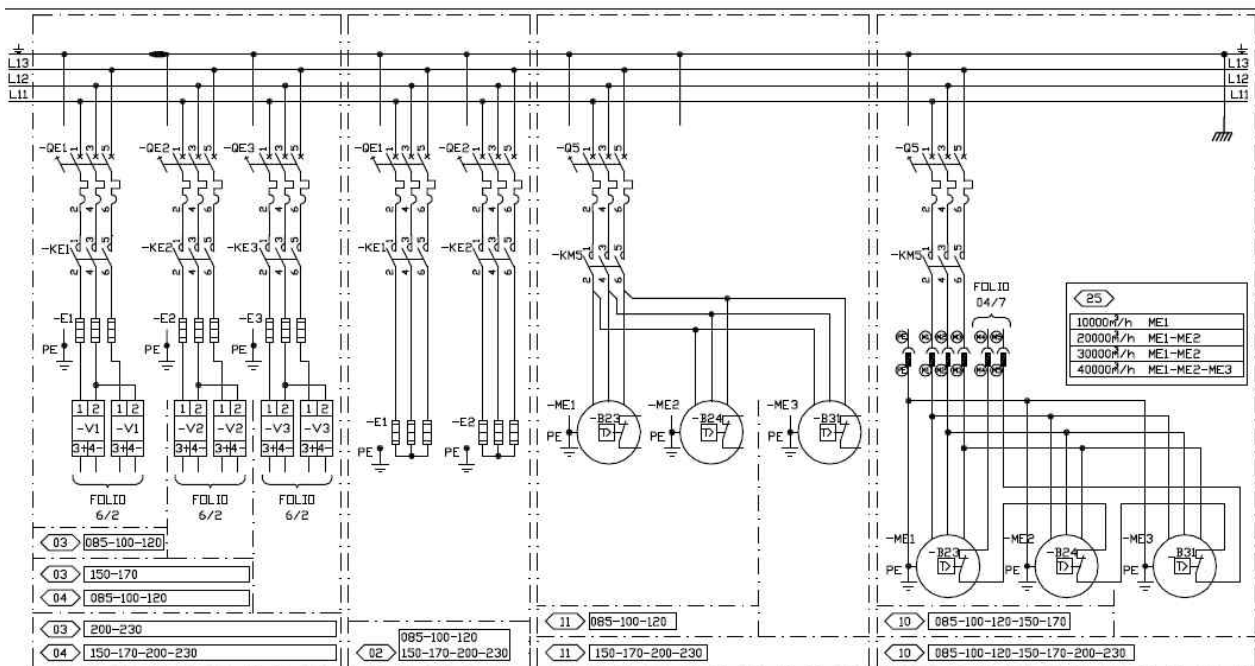
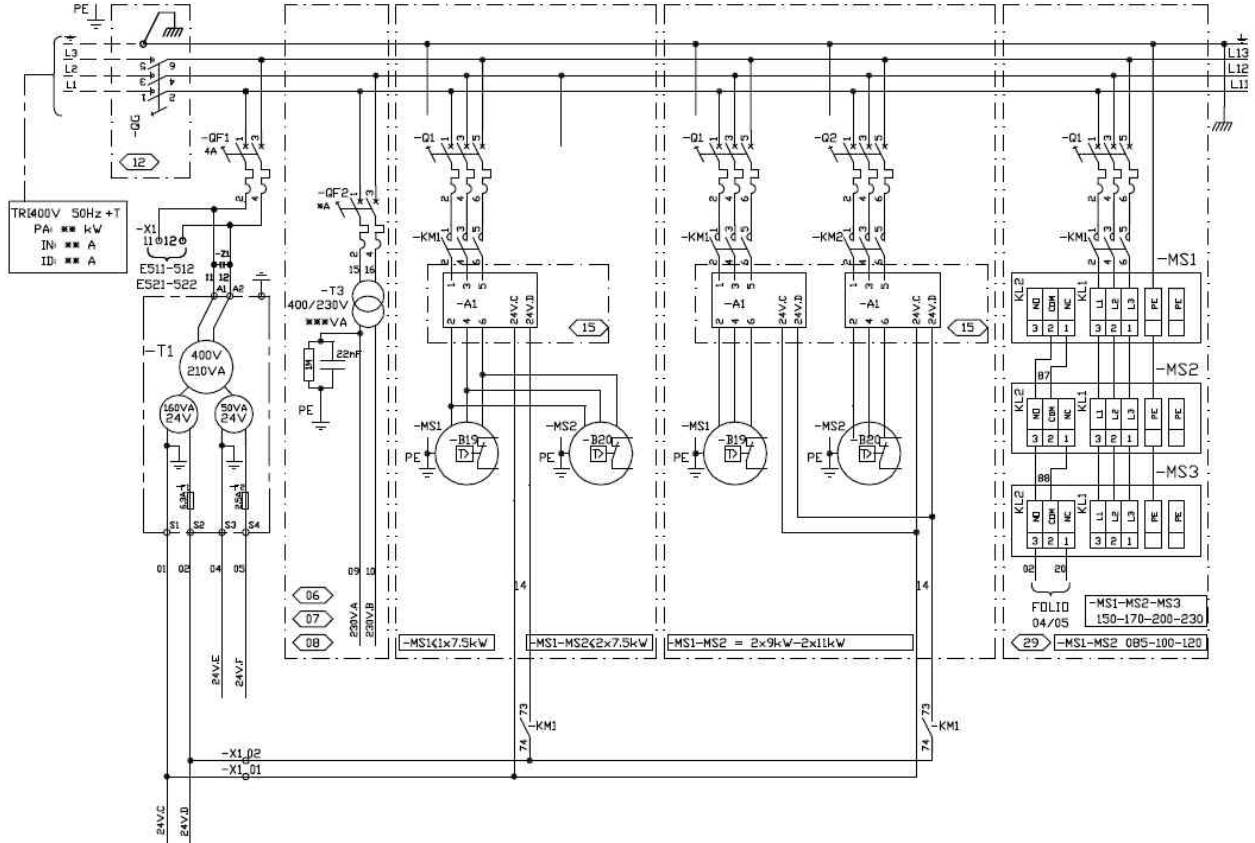



MAIN CURRENT DIAGRAM TRI / 400V / 50Hz + T

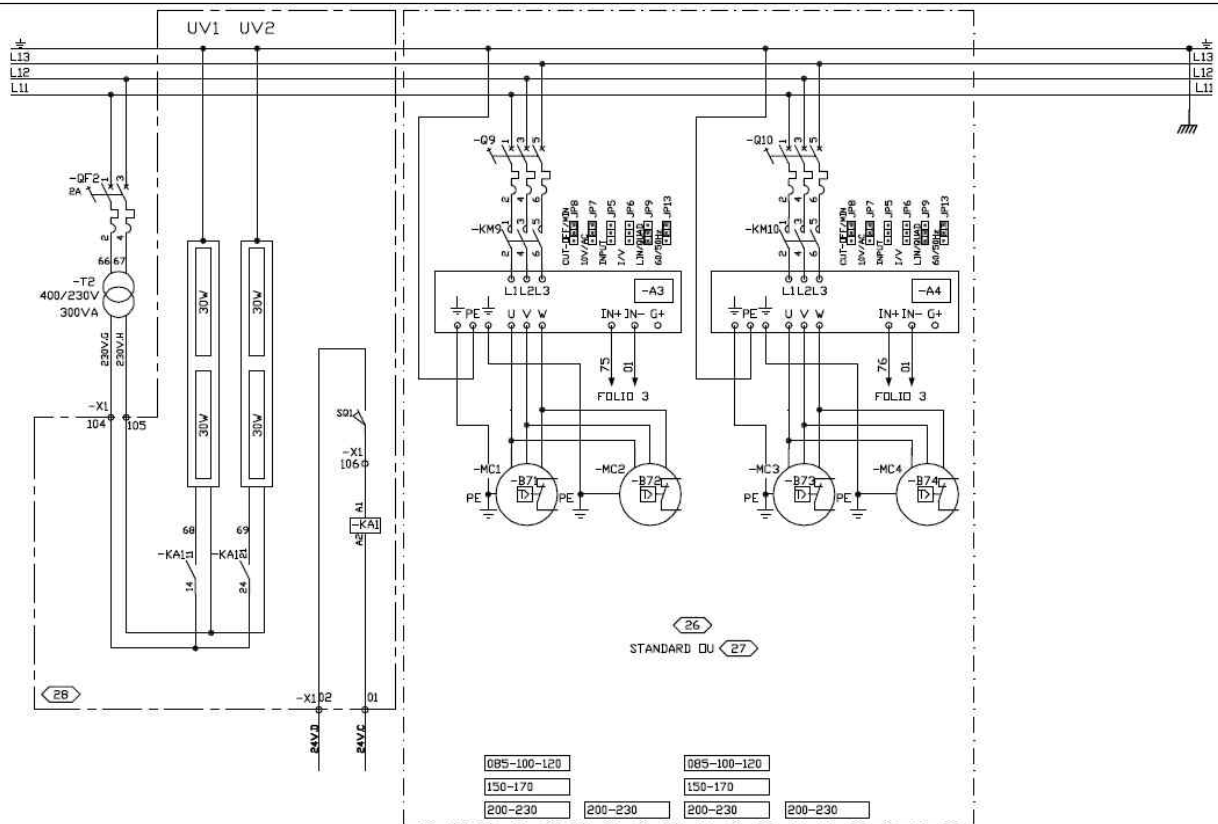
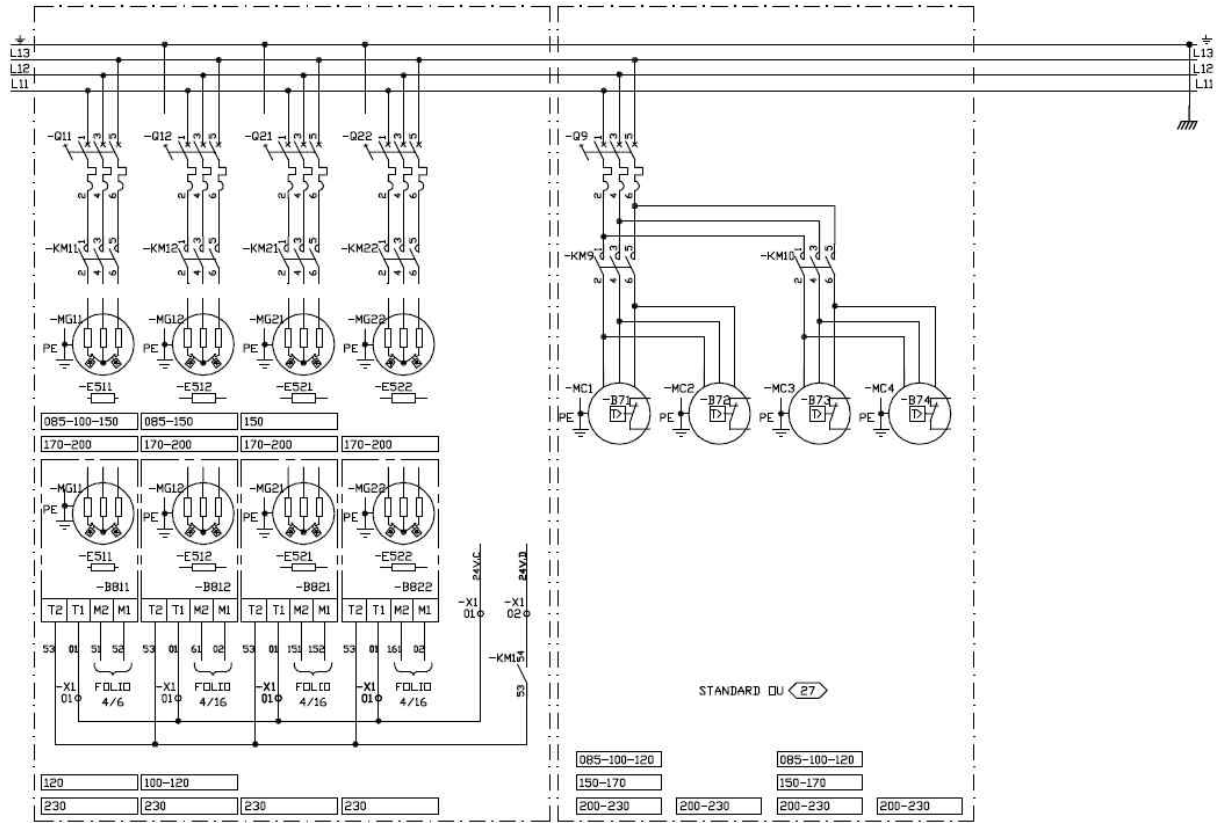



CLIMATIC 50 INPUT FCM / FHM / FGM / FDM

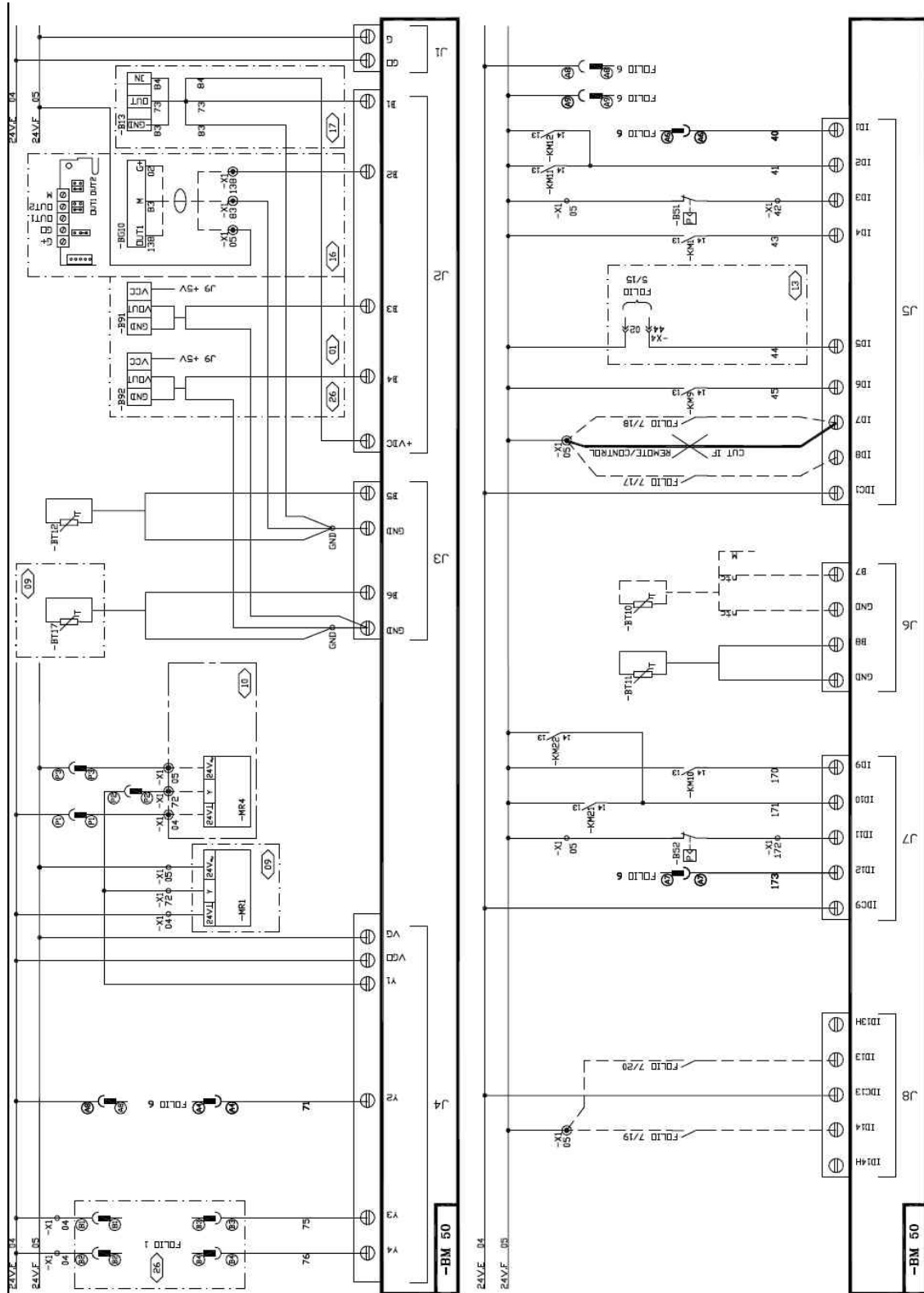

CLIMATIC 50 OUTPUT FCM / FHM / FGM / FDM

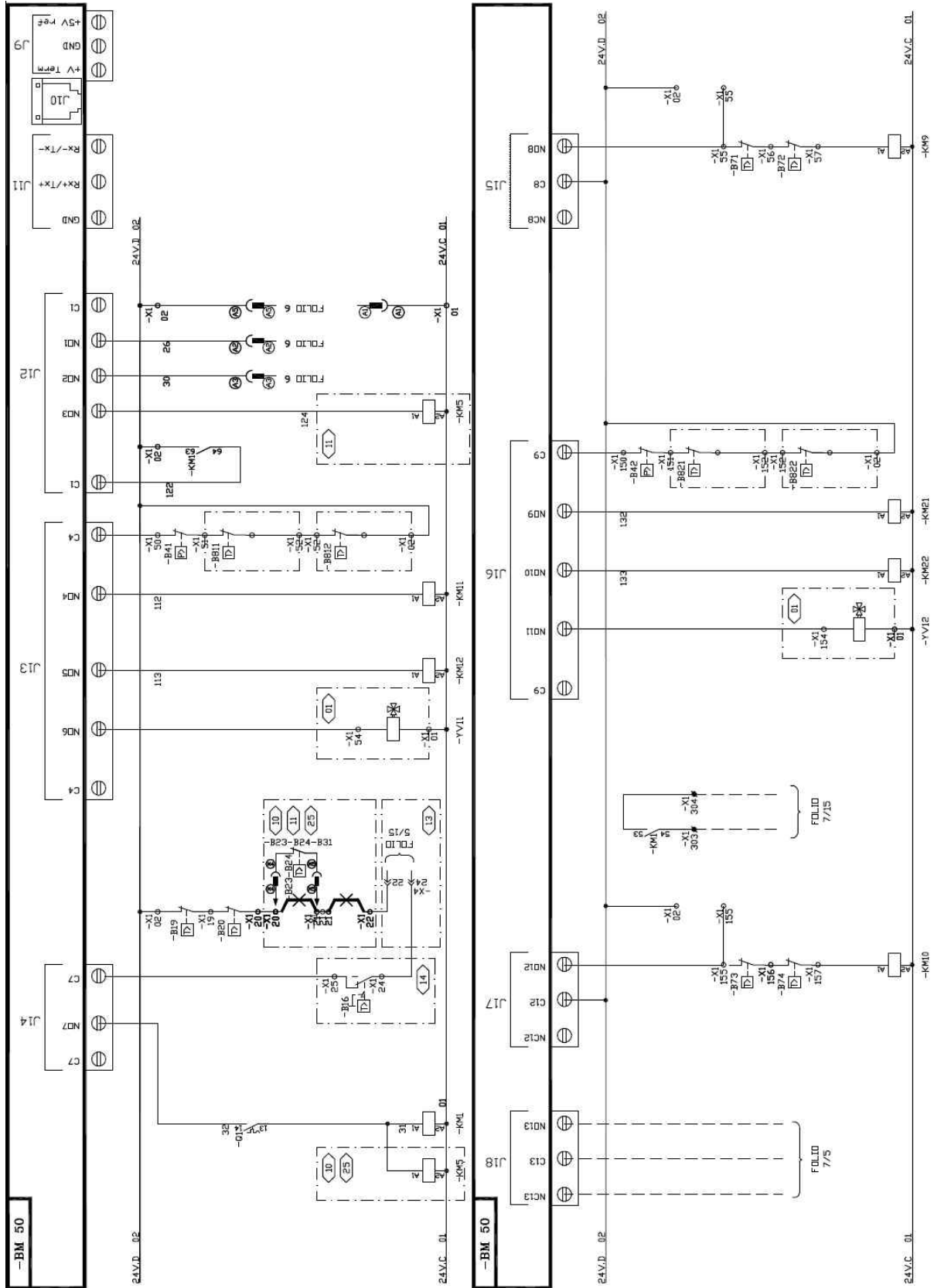

DAD SMOKE DETECTOR

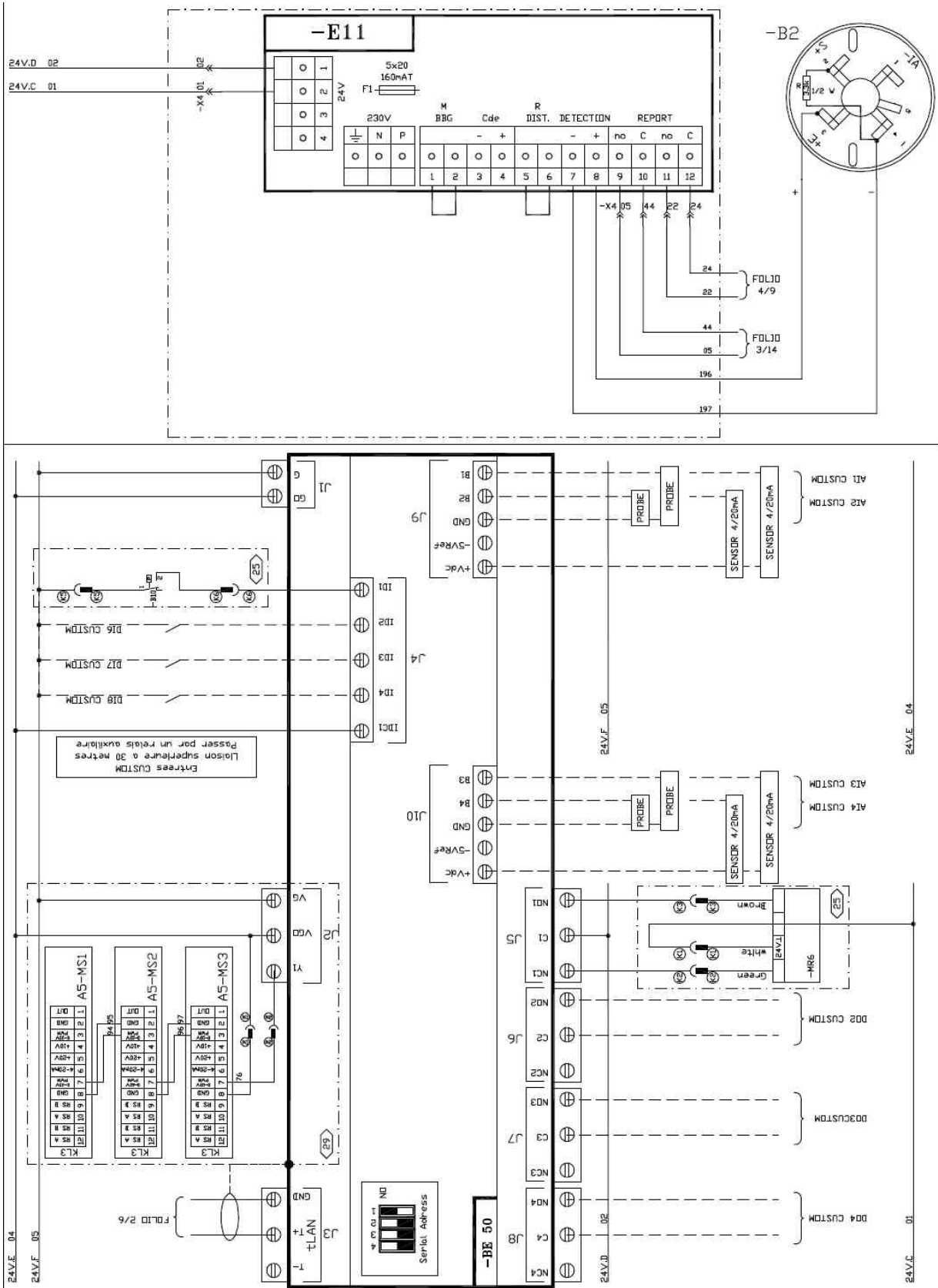

GENERAL CUSTOMER CONNECTION TCB

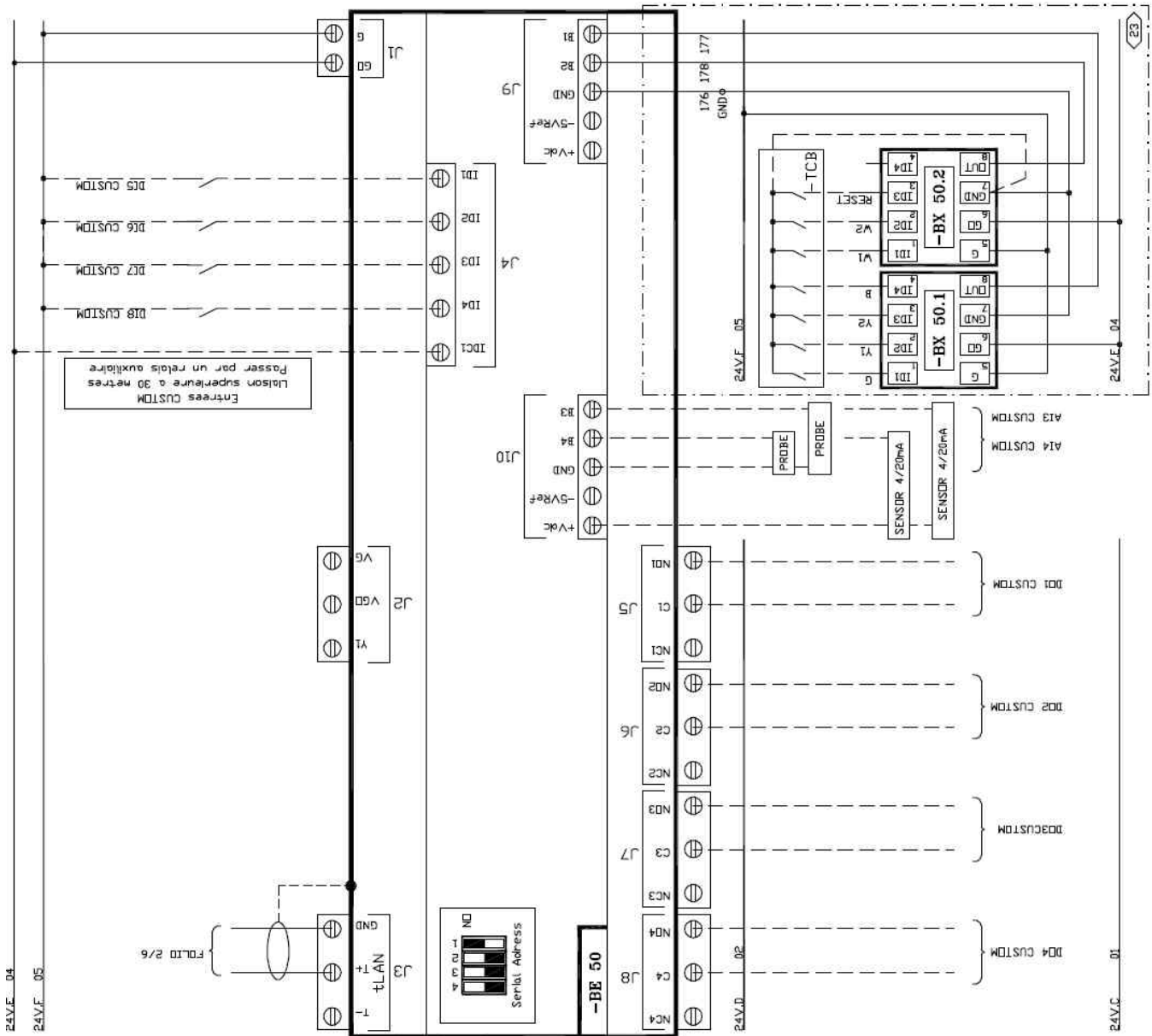







WIRING DIAGRAM GAS BURNER 120KW

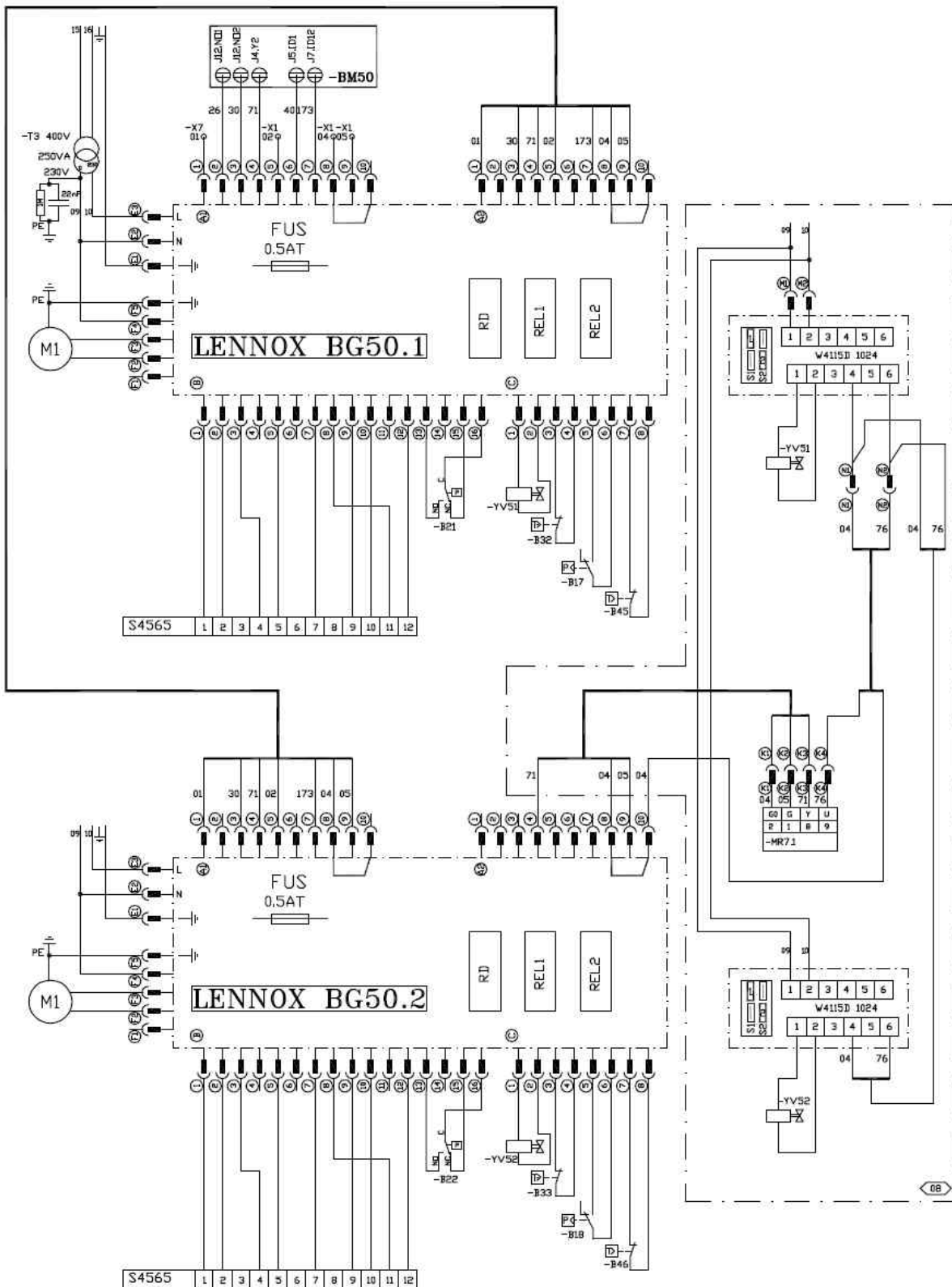

WIRING DIAGRAM GAS BURNER 180 / 240kW

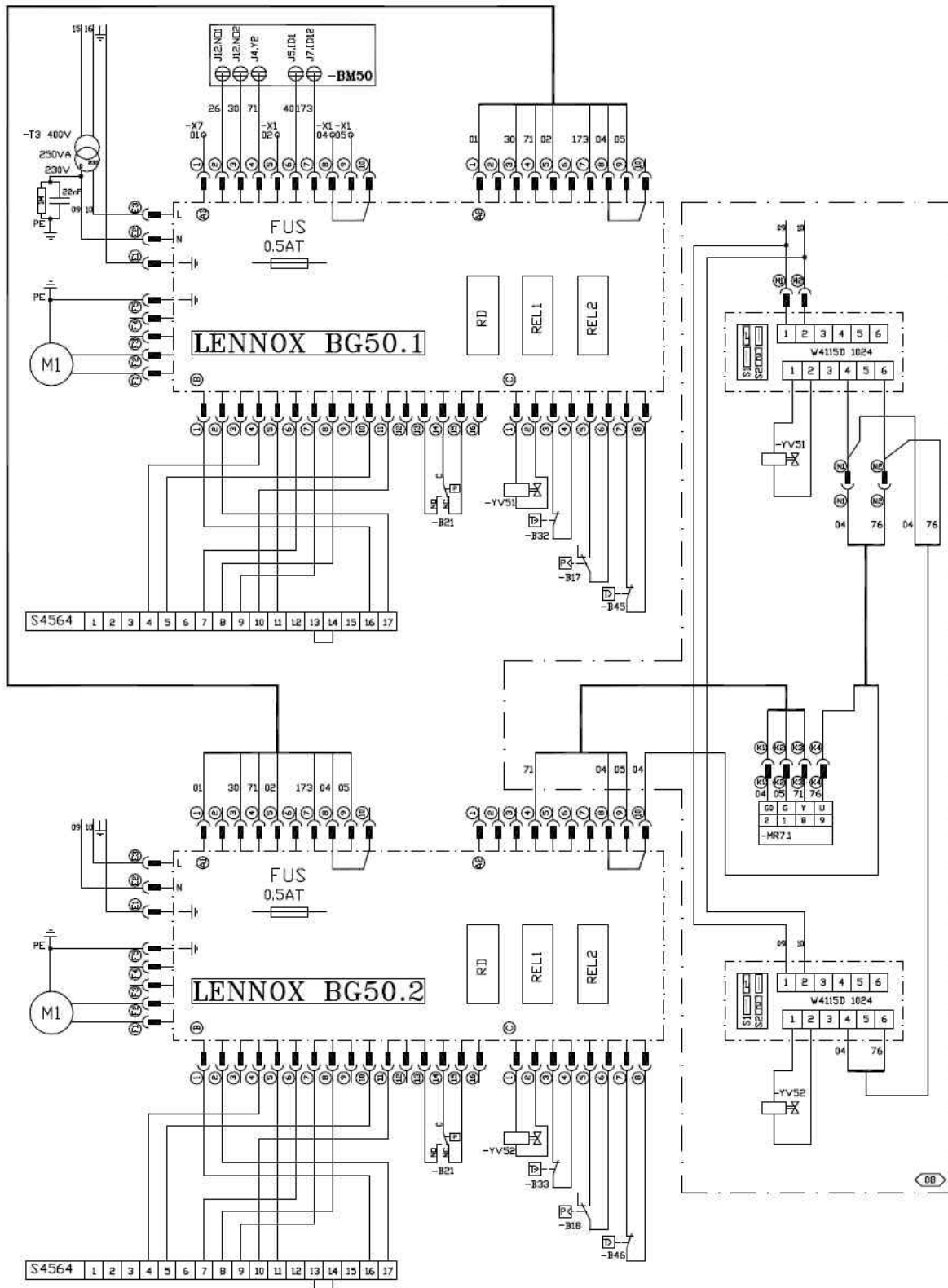

WIRING DIAGRAM ELECTRIC HEATER

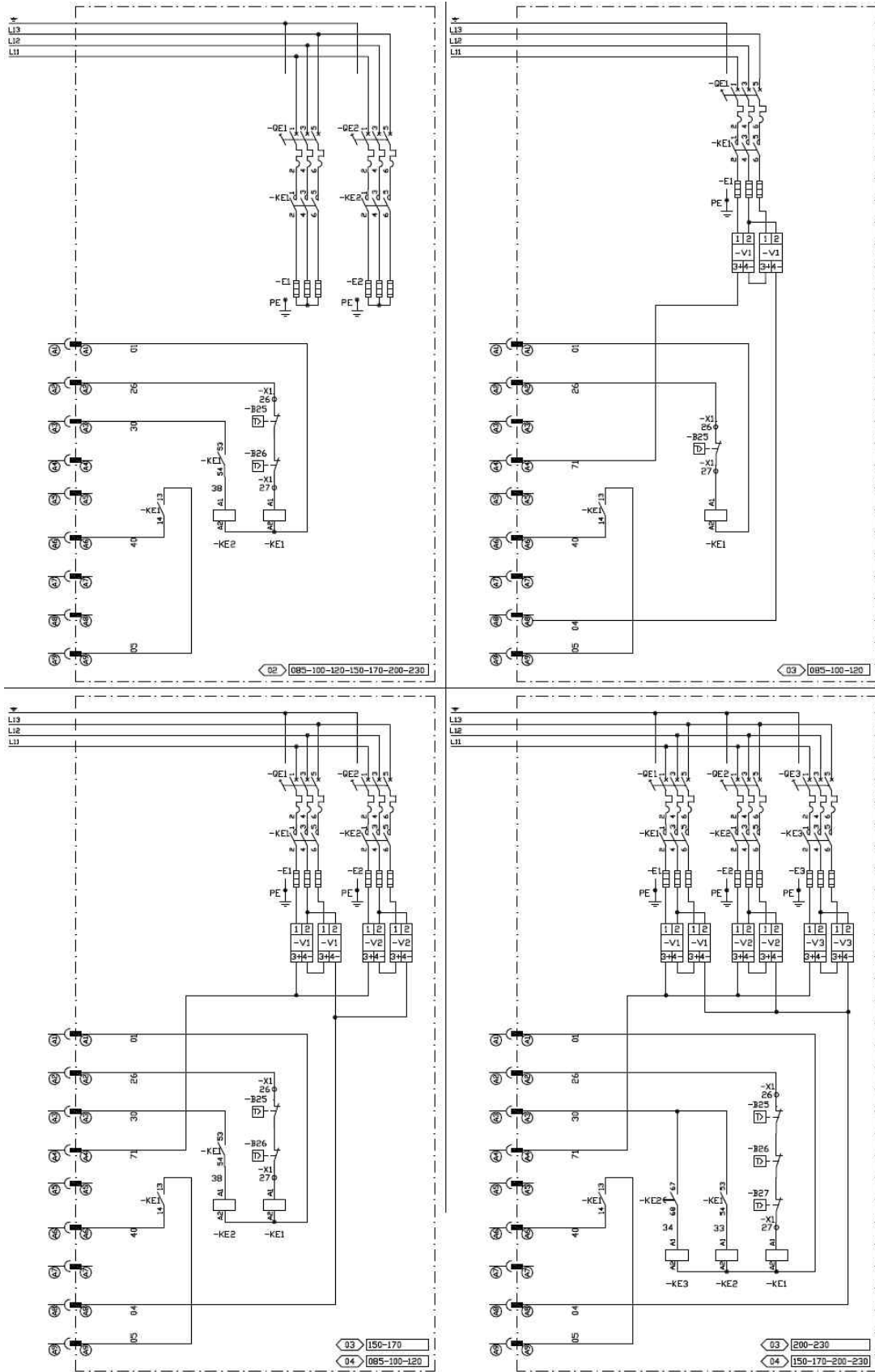

GENERAL CUSTOMER CONNECTION DIAGRAM

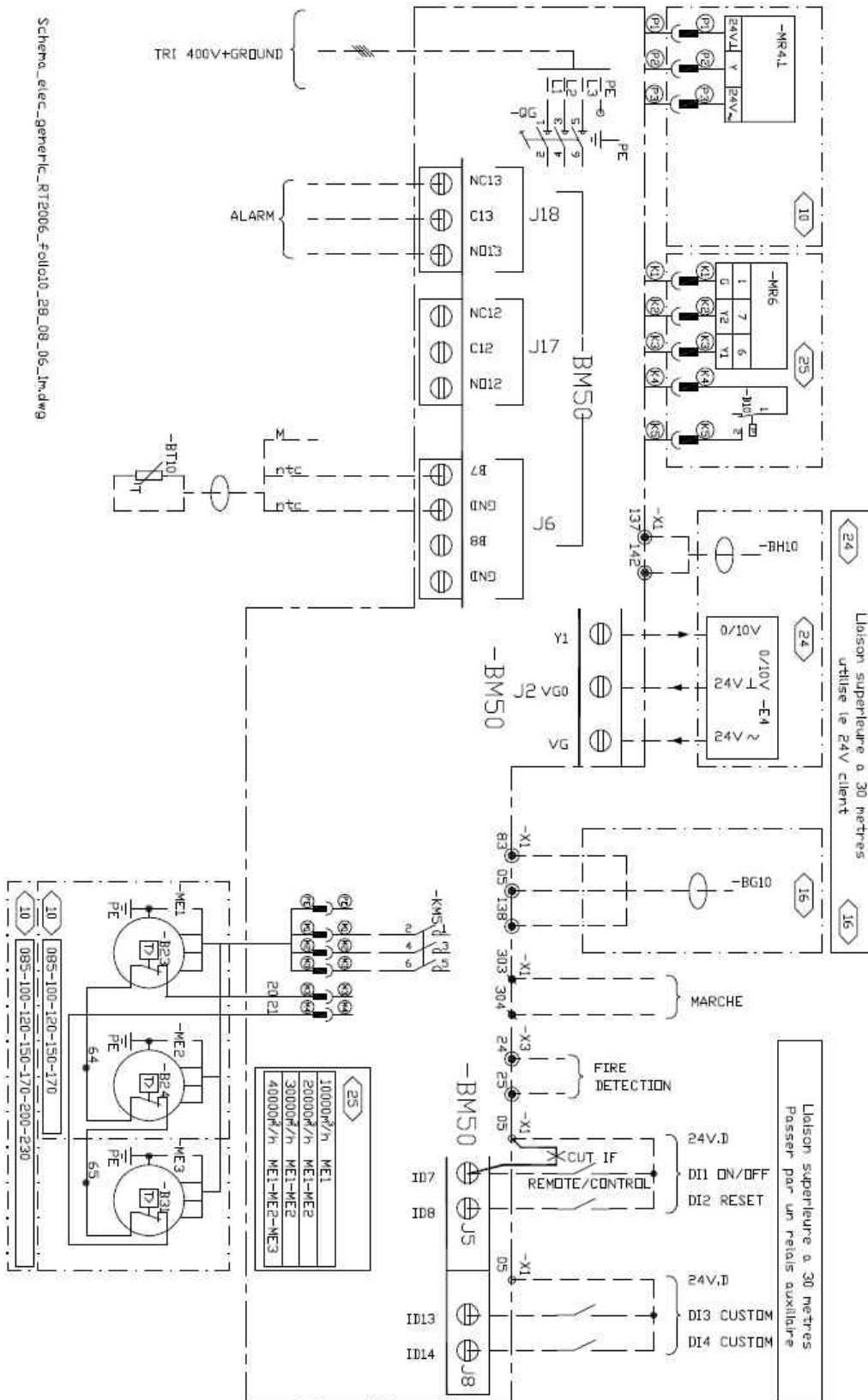

Schema\_elec\_generic\_RT2006\_folia10\_29\_09\_06\_1h.dwg

**STANDARD**

**Logical Output Board**

(2 outputs: 1 assigned, 1 customized)

DO 1 - Alarm, General  
 DO 2 - Customized (choose 1 output between those 7 possibilities)

- Alarm, Filters
- Alarm, Blower
- Alarm, Compressors
- Alarm, Gas
- Alarm, Electric Heater
- Alarm, Hot Water Coil Freezing
- Alarm, Smoke detector
- Heating mode
- Humidifier
- Zone A, Activated
- Zone B, Activated
- Zone C, Activated
- Zone Uno, Activated
- Zone BMS, Activated
- Free, for BMS

**Logical Input Board**

(4 inputs: 2 assigned, 2 customized)

DI 1 - ON/OFF  
 DI 2 - Reset alarm  
 DI 3 & 4 - Customized (choose, for each input (2) between those 12 possibilities)

- Zone Uno Activate
  - Disable, Compressors & Heaters
  - Disable, Compressors
  - Disable, 50% Compressors
  - Disable, Heaters
  - Disable, Cooling
  - Disable, Heating
  - Fault contact, Humidifier
  - 0 % Fresh air
  - 10 % Fresh air
  - 20 % Fresh air
  - 30 % Fresh air
  - 40 % Fresh air
  - 50 % Fresh air
  - 100 % Fresh air
  - Free, for BMS
- } Those contacts add up

**ADVANCED CONTROL PACK OR TCB**

**Logical Output Board**

(4 outputs: 0 assigned, 4 customized)

DO 3 to 6 - Customized (choose, for each input (4) between those 7 possibilities)

- Alarm, Filters
- Alarm, Blower
- Alarm, Compressors
- Alarm, Gas
- Alarm, Electric Heater
- Alarm, Hot Water Coil Freezing
- Alarm, Smoke detector
- Heating mode
- Humidifier
- Zone A, Activated
- Zone B, Activated
- Zone C, Activated
- Zone Uno, Activated
- Zone BMS, Activated
- Free, for BMS

**Logical Input Board**

(4 outputs: 0 assigned, 4 customized)

DI 5 to 8 - Customized (choose, for each input (4) between those 12 possibilities)

- Zone Uno Activate
  - Disable, Compressors & Heaters
  - Disable, Compressors
  - Disable, 50% Compressors
  - Disable, Heaters
  - Disable, Cooling
  - Disable, Heating
  - Fault contact, Humidifier
  - 0 % Fresh air
  - 10 % Fresh air
  - 20 % Fresh air
  - 30 % Fresh air
  - 40 % Fresh air
  - 50 % Fresh air
  - 100 % Fresh air
  - Free, for BMS
- } Those contacts add up

**Analogue Input Board**

(4 outputs: 0 assigned, 2 customized)

AI 1 & 2 - Customized (choose, for each input (4) between those 4 possibilities)

- Override room temp set point -5 +5°C (4-20mA)
- Override fresh air set point 0-100% (4-20mA)
- Weather Temperature -40°C +80°C (4-20mA)
- Weather Humidity 0% 10% (4-20mA)
- Free temperature (NTC probe)
- Free relative humidity (4-20mA)

**REFRIGERANT DEFINITION**

R-410A is an HFC, or hydro fluorocarbon, and is made of hydrogen, fluorine, and carbon atoms. Because it has no chlorine, it won't interact with the ozone layer once it breaks down. It's non-toxic and non-flammable.

**CHEMICAL CHARACTERISTICS OF REFRIGERANT**

Name	R22	R407C	R410A
Component	HCFC22	HFC32/HFC125/HFC134a	HFC32/HFC125
Composition (%)	100	23/25/52	50/50
Type of refrigerant	Single refrigerant	Non-azeotropic refrigerant mixture	Near azeotropic refrigerant mixture
Chlorine	Contained	Not contained	Not contained
Safety Class *1	A1	A1/A1	A1/A1
Ozone Depletion Potential (ODP) *2	0.055	0	0
Global Warming Potential (GWP) *3	1700	1530	1730
Refrigerant charging method	Gas change	Refrigerant is taken out from the liquid phase of gas cylinder	Refrigerant is taken out from the liquid phase of gas cylinder
Additional charge due to refrigerant leakage	Possible	Possible temporarily	Possible

\*1 see table below :  
*Refrigerant Safety classifications from ASHRAE Standard*

	Lower toxicity	Higher toxicity	
Higher flammability	A3	B3	LFL≤0.10kg/m3 or heat of combustion≥19000kJ/kg
Lower flammability	A2	B2	LFL>0.10kg/m3 and heat of combustion >19000kJ/kg
No flame propagation	A1	B1	No LFL
	No identified toxicity at concentration ≤ 400ppm	Evidence of toxicity below 400ppm	

LFL = Lower Flammability Limit

\*2 Based on CFC11

\*3 Based on CO2

**STANDARDS THAT MUST BE MET WITH R410A:**

- An ester oil (POE) is used for R410A (as with R407c)
- It's important to work with absolute cleanliness
- Brazing must be done with the use of Nitrogen (OFN)
- The system must be evacuated thoroughly (0.3mbar or less)
- The system must always be charged in the liquid phase

**SATURATION PRESSURE**

Temp. °C	Saturation pressure (relative pressure in bars)		
	R22	R407C Vapor	R410A
70	28.97	31.94	46.54
65	26.01	28.55	41.7
60	23.27	25.44	37.29
58	22.24	24.26	35.63
56	21.24	23.13	34.03
54	20.27	22.04	32.49
52	19.33	20.99	31.01
50	18.43	19.98	29.57
48	17.55	19	28.19
46	16.70	18.05	26.86
44	15.89	17.14	25.57
42	15.10	16.26	24.33
40	14.34	15.42	23.14
38	13.60	14.61	21.99
36	12.89	13.82	20.88
34	12.21	13.07	19.81
32	11.55	12.35	18.79
30	10.92	11.65	17.8
28	10.31	10.99	16.85
26	9.72	10.35	15.93
24	9.16	9.73	15.06
22	8.62	9.14	14.21
20	8.10	8.58	13.41
18	7.60	8.04	12.63
16	7.12	7.52	11.89
14	6.67	7.03	11.17
12	6.23	6.55	10.49
10	5.81	6.1	9.84
8	5.41	5.67	9.21
6	5.03	5.26	8.61
4	4.66	4.87	8.04
2	4.31	4.5	7.5
0	3.98	4.14	6.98
-2	3.66	3.81	6.48
-4	3.36	3.49	6.01
-6	3.08	3.19	5.56
-8	2.81	2.9	5.14
-10	2.55	2.63	4.73
-12	2.30	2.37	4.35
-14	2.07	2.13	3.98
-16	1.85	1.9	3.64
-18	1.65	1.68	3.31
-20	1.45	1.48	3

**OPERATION MODE EXPLANATION**

- ❖ Protection is activated when Scroll Discharge Port. Reaches **150°C** (+/- 17K)
  - ❖ Compressor is protected as « Unloaded » but continues to run
    - Protection mode balances discharge/suction pressure
      - Motor heat builds inside compressor
      - No refrigerant flow to carry motor heat away
  - ❖ Motor protector opens (Klyxon)
    - Compressor turns off, cools
  - ❖ Motor protector resets, compressor restarts
    - Bi-metal disk resets before motor protection
    - Cycle will continue until cause of overheat is fixed

**SERVICE A COMPRESSOR**

- ❖ What to do?
  - If a protected compressor is identified
    - Stop the compressor
    - Allow to cool thoroughly
    - Restart pump & check for normal operation
- ❖ DO NOT ASSUME A COMPRESSOR RUNNING UNLOADED (BALANCE PRESSURE) IS A FAILURE
- ❖ Likely situations where protection may activate :
  - Initial system charging (or recharging after servicing)
    - Compressor is run with too little system charge
      - Very common on split system
      - Will result in very low suction pressures (<1.7 Bars)
      - Do not disable low pressure cutouts while charging
      - Charge high-side with liquid first
  - Field servicing (system problem causes overheating)
    - Technician will observe « Balanced pressures »
    - Risk of misdiagnosis as failed compressor
    - Must stop pump, cool thoroughly, reset

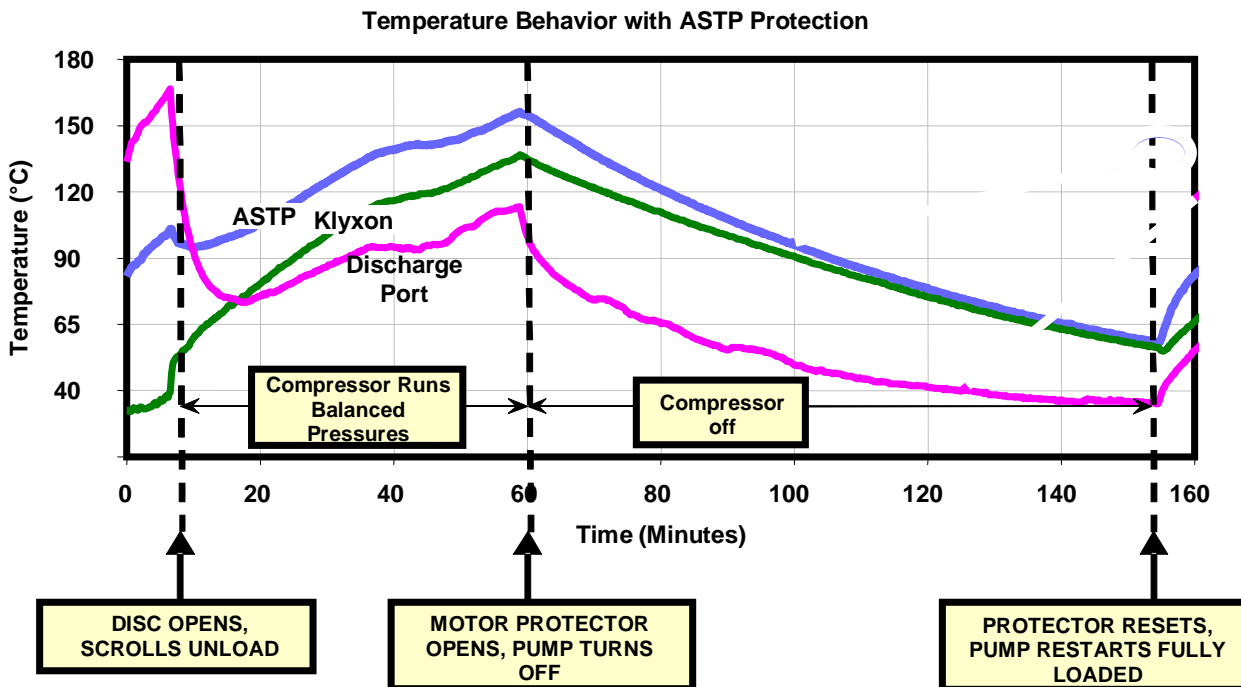

BCD1.2	CONDENSER COIL
BEC	HOT WATER COIL
BEV	EVAPORATOR COIL
CA1.2	CHECK VALVE
DT1.2	THERMOSTATIC EXPANSION VALVE
FD1.2	FILTER DRIER
- B14 - B15	HOT WATER COIL ANTIFREEZE THERMOSTAT
- BT12	BLOWER TEMPERATURE PROBE
- BT17	RETURN REGULATION TEMPERATURE SENSOR
- B41 - B42	COMPRESSOR -MG1 - MG2 HIGH PRESSURE SAFETY SWITCH
- B51 - B52	COMPRESSOR -MG1 - MG2 LOW PRESSURE SAFETY SWITCH
- B61 - B62	COMPRESSOR -MG1 - MG2 HIGH PRESSURE CONTROL SWITCH
- MC1 - MC2	CONDENSER -MC1 - MC2 FAN MOTOR
- MC3 - MC4	CONDENSER -MC3 - MC4 FAN MOTOR
- MG11 - MG12	COMPRESSOR -MG1 - MG2
- MG21 - MG22	COMPRESSOR -MG3 - MG4
- MS1 - 2	BLOWER FAN MOTOR -MS1
VAM1.2	MANUAL CHECK VALVE
VRM	MANUAL REGULATION VALVE
- YV2	HOT WATER 3-WAY VALVE
- YV11 - YV12	COMPRESSOR -MG1 - MG2 REVERSAL CYCLE VALVE

**FCM 085 to 120**

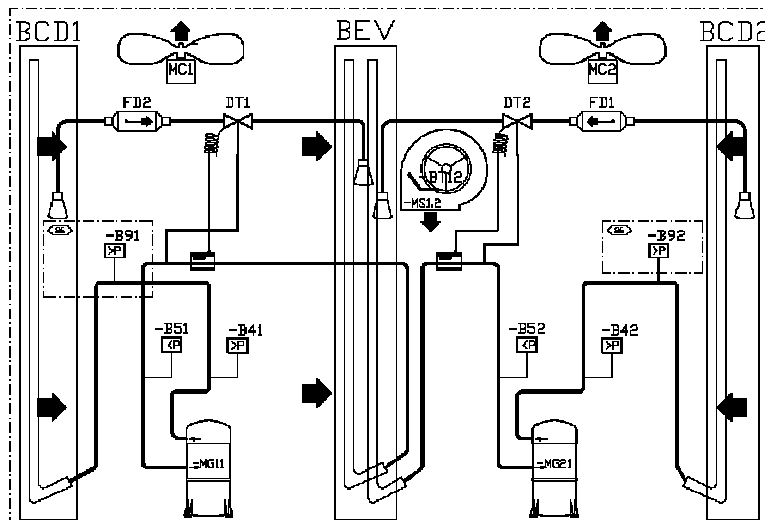

**FHM 085 to 120**

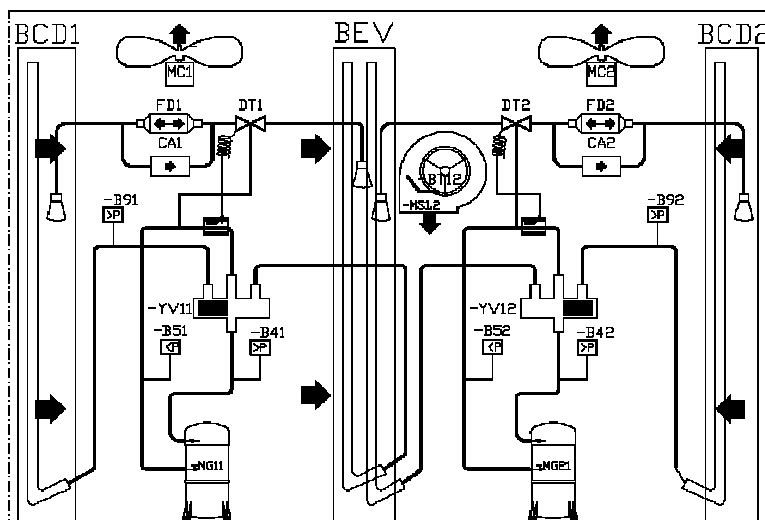



**FCM 150**

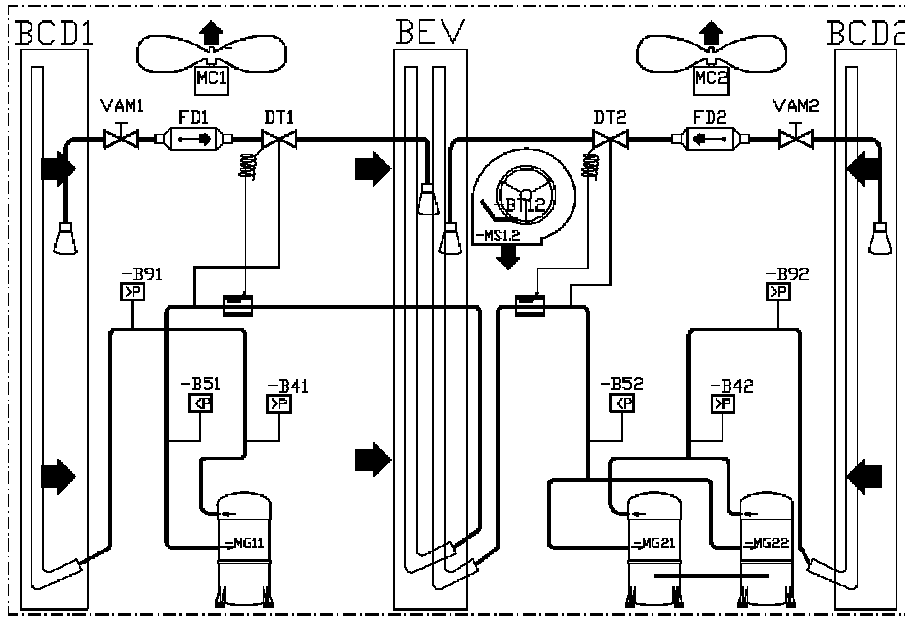

**FHM 150**

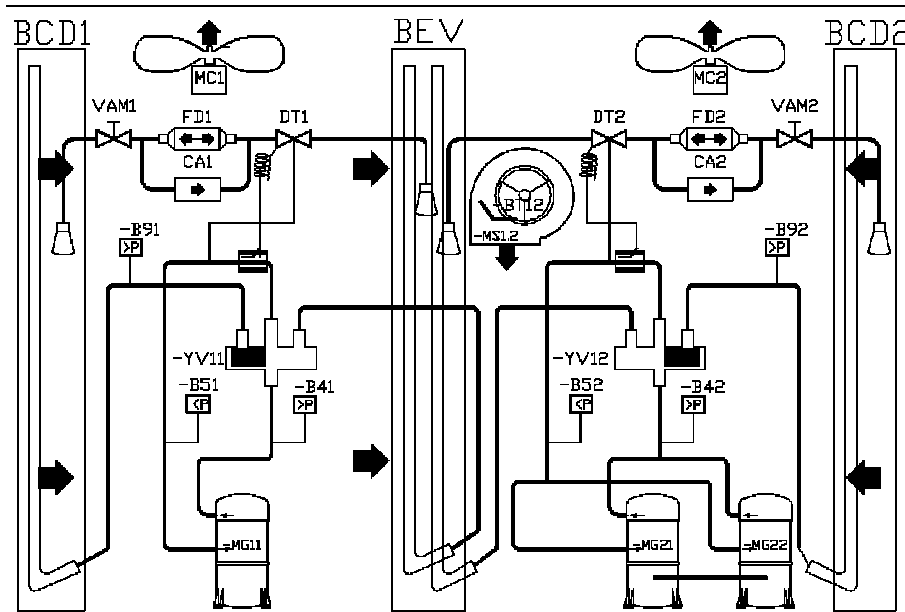

**FCM 170**

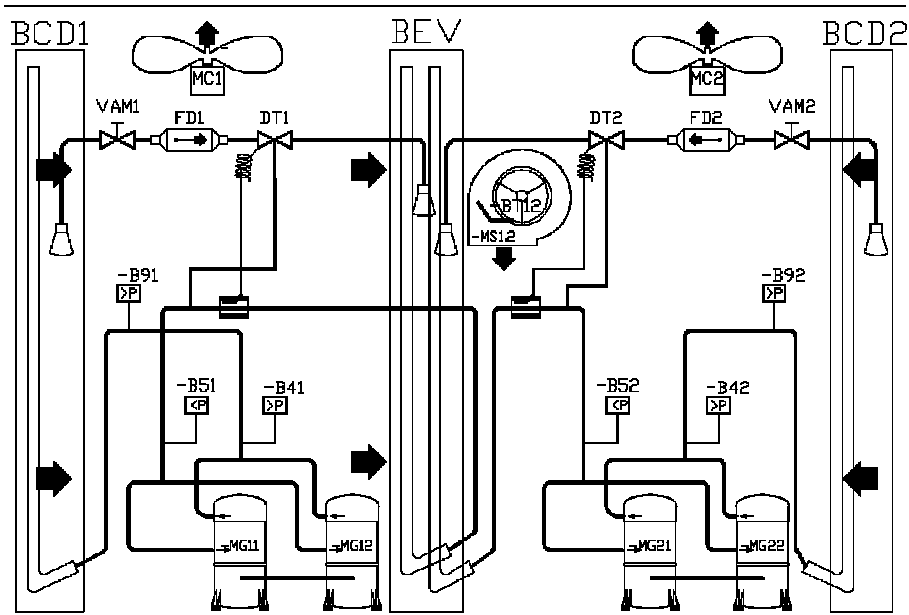

**FHM 170**

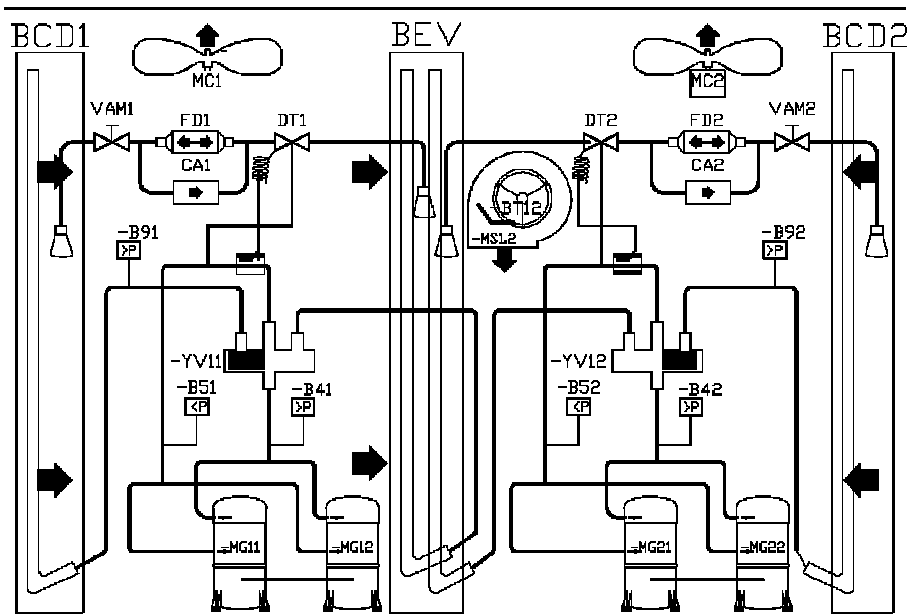

**FCM 200 & 230**

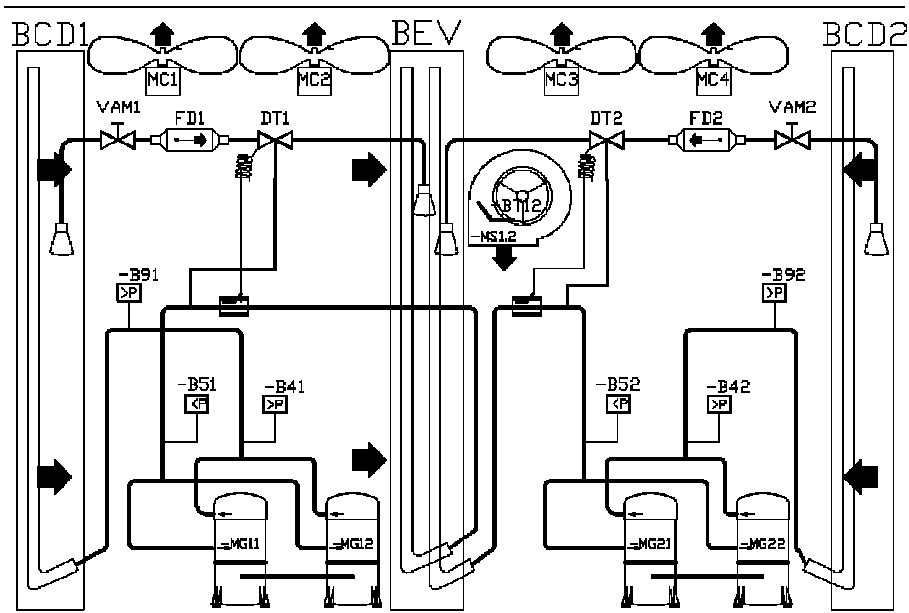

**FHM 200 & 230**

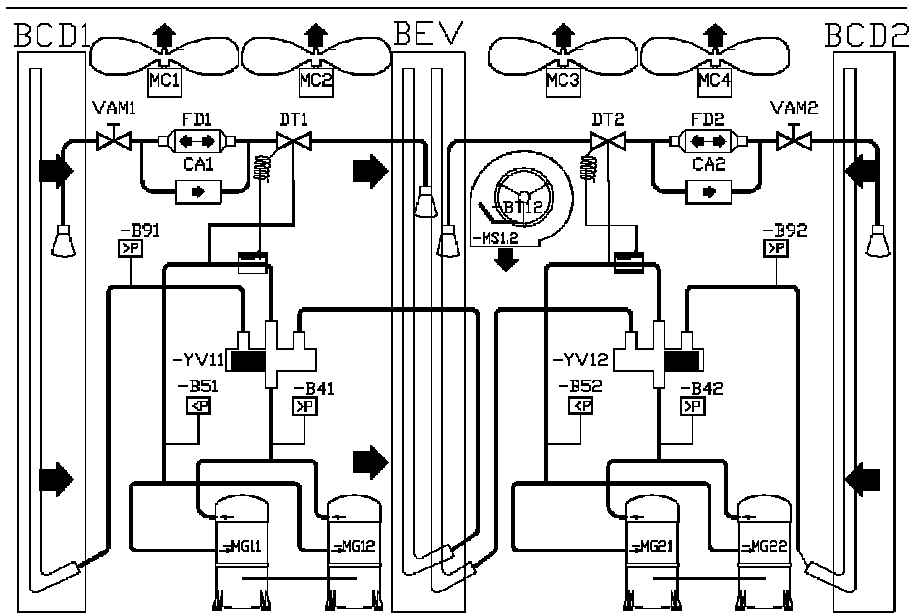

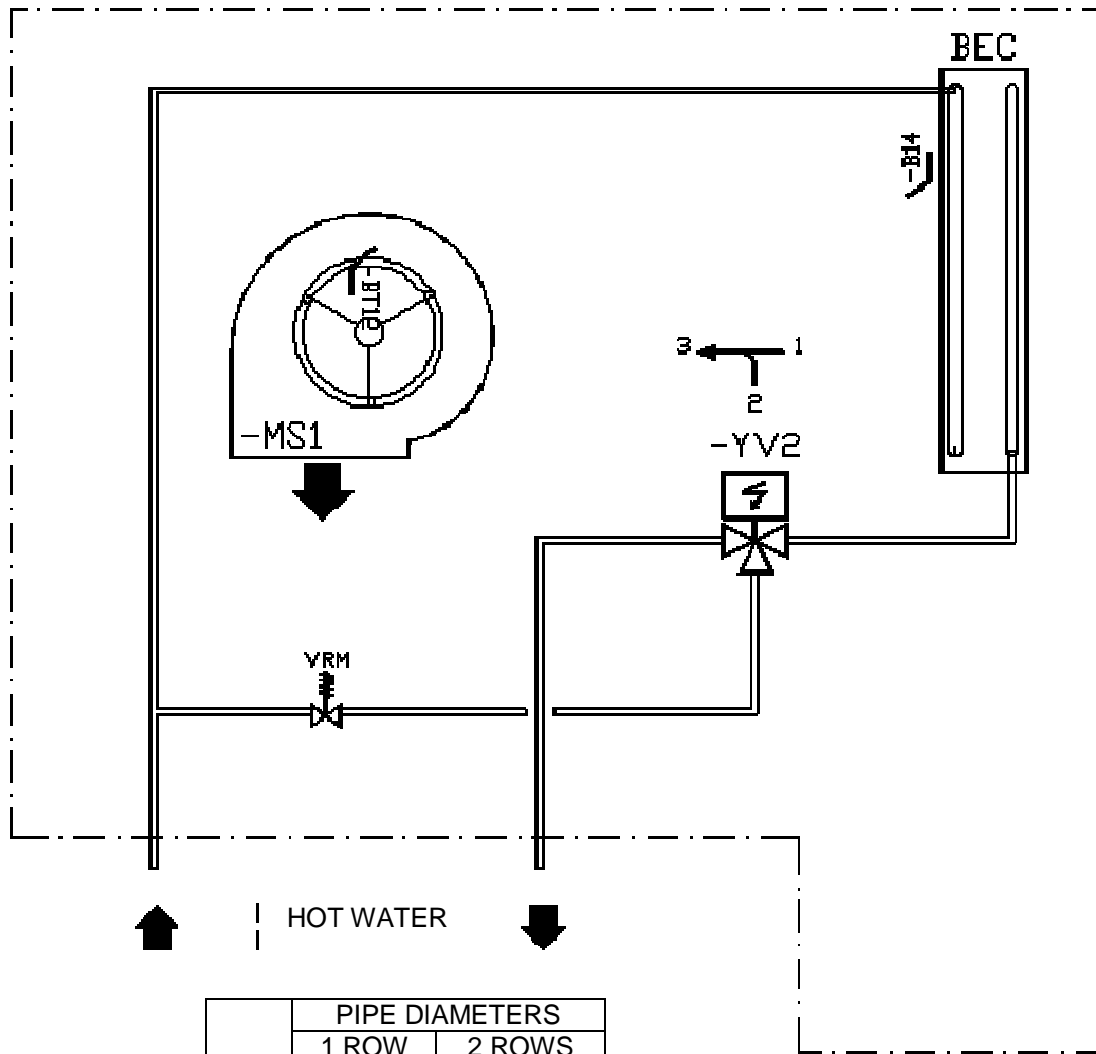

	PIPE DIAMETERS	
	1 ROW	2 ROWS
085	25	32
100	25	32
120	25	32
150	32	40
170	32	40
200	32	40
230	32	40

REFRIGERATION

FAULT	POSSIBLE CAUSE AND SYMPTOMS	SOLUTION
LP PROBLEMS and LP CUT OUTS	Refrigerant charge too low	Measure the superheat and sub-cooling: Good if $5^{\circ}\text{C} < \text{SC} < 10^{\circ}\text{C}$ and $5^{\circ}\text{C} < \text{SH} < 10^{\circ}\text{C}$ Bad if $\text{SC} > 10^{\circ}\text{C}$ and SH too Low Check superheat adjustment and charge unit (a leak check must be carried out)
	In Heat Pump Mode the temperature difference between T outdoor and T <sub>evap.</sub> (Dew) is too high  $5^{\circ}\text{C} < \Delta T < 10^{\circ}\text{C}$ excellent $10^{\circ}\text{C} < \Delta T < 15^{\circ}\text{C}$ acceptable $15^{\circ}\text{C} < \Delta T < 25^{\circ}\text{C}$ too high	If too high check the coils are clean or check coil internal pressure drop between the liquid line and the suction line Good if $< 3\text{bar}$ Too high if $> 3\text{bar}$ (coil blocked)
	Refrigeration circuit blocked in distribution	Stop the fan and create icing of the coil. Check all circuits freeze evenly across the whole surface of the coil If some parts of the coil do not freeze this could indicate a problem with the distribution
	Liquid line drier blocked. High temperature difference between inlet and outlet of the drier	Change filter drier
	Contaminant in the expansion valve	Attempt to free the valve adjusting element by freezing the valve and then heating the thermostatic element. Replace the valve if necessary
	Expansion valve not adjusted properly	Adjust the expansion Valve
	Ice plug in the expansion valve.	Heat the main body of the valve. If the LP increases and then decreases gradually, empty the circuit and replace the drier.
	Incorrect insulation of the thermostatic bulb of the expansion valve	Superheat too low: adjust superheat Move the thermostatic element along the pipe Insulate the Thermostatic element of the valve
	Low Pressure Switch cut out point too high	Check the cut out pressure of the Low Pressure switch: It must be $0.7 \pm 0.2\text{bar}$ and must closes at $2.24 \pm 0.2\text{bar}$
	LP cut out due to not enough defrost on heat pumps	Adjust the CLIMATIC settings to extend the defrost cycles or shorten the time between defrosts
HP PROBLEMS AND HP CUT OUTS	Incorrect Airflow rates	<u>Heat pump mode:</u> Check the filter before the indoor coil measure and estimate the airflow rate increase the speed of the fan <u>Cooling mode:</u> Check the condenser fan (Amps)
	Moisture or contaminants in the system	Summer operation Several hours after the unit has stopped, check the correspondence between the measured pressure and the outdoor temperature

HP PROBLEMS AND HP CUT OUTS	Moisture or contaminants in the system	If the circuit pressure is higher (<1bar) than the saturated pressure corresponding to the measured outdoor temperature, there is possibility that some contaminants are present in the system. Reclaim the refrigerant, and vacuum the circuit (Ensure very low and slow vacuum for R407c) Recharge the unit
	Condenser coil is obstructed	Check the condenser coil and clean is necessary
	Recycled Hot Air	Check clearance around the condenser
Strong variations of pressure ( 2 to 3 bar) Thermostatic Expansion Valve "hunting"	Incorrect adjustment of the expansion valve	Refer to LP problems and LP cut out section
	Low refrigerant charge Filter drier obstructed with gas bubbles at the expansion valve inlet Moisture in the system	
Very high discharge temperature, High amps measured at compressor	Very high superheat, very hot compressor	Open the superheat adjustment on the expansion valve. Check the pressure drop on the filter drier in the suction line
	Four Way reversing valve possibly blocked, abnormal noise from the valve, low LP and increasing HP	Check operation of the valve by going through cycle inversions. Change if necessary. Refer to LP problems

**INDOOR FAN BLOWER**

FAULT	POSSIBLE CAUSE AND SYMPTOMS	SOLUTION
High amps on action Fan motor	Pressure drop in the ducting installation too low.	Reduce the rotation speed of the fan Measure and estimate the airflow and pressure and compare with the specification from customer.
High amps on reaction Fan motor	Pressure drop in the ducting installation too high.	Reduce the rotation speed of the fan Measure and estimate the airflow and pressure and compare with the specification from customer.
Unstable running and high vibration	Fan jumping from one operating point to the other	Change rotation speed of the fan.

**OUTDOOR AXIAL FAN**

FAULT	POSSIBLE CAUSE AND SYMPTOMS	SOLUTION
Heat Pump mode: Circuit breaker open	High Amps due to a low voltage from the main supply	Check the voltage drop when all components are running. Change the circuit breaker for one with a higher rating.
	High amps due to freezing of the coil	Check the adjustable amps on the motor starter. Adjust the defrost cycle set points.
	Flexy: Water ingress in the motor connection box.	Change the component

**ELECTRICAL HEATER**

FAULT	POSSIBLE CAUSE AND SYMPTOMS	SOLUTION
High Temperature trip out on electric heater	Low airflow rate	Measure and estimate the airflow and pressure and compare with the specification from customer.
	Incorrect position of the Klixon	Check that the Klixon, is positioned in the airflow, relocate Klixon if necessary Check that there is no heat transfer from the Klixon support.

**WATER LEAKS**

FAULT	POSSIBLE CAUSE AND SYMPTOMS	SOLUTION
Water found in the ventilation section	Cooling mode: Water carried away from the coil because of excessive airflow and speed on the coil.	Estimate the airflow rate and check the speed is lower than 2.8 m/s
	Low air pressure in the compartment due to a high airflow rate or a high pressure drop before the fan	Check filter Reduce airflow rate
	Check seals around the ventilation section.	Check the door seal Check for the presence of silicone seals in the corners of the door and at the bottom of the refrigeration section bulkhead.
Water ingress in the filter compartment	Water ingress through a leaking fresh air hood or when running 100% fresh air	Check the seals and flanges in the fresh air hood Reduce the airflow rate if necessary

**DC50 & DS50**

FAULT	POSSIBLE CAUSE AND SYMPTOMS	SOLUTION
DC50: Nothing is written on the screen but it's enlightened	Problem of addressing pLAN on the DC50	Press on the three right-hand side's buttons at the same time during a few seconds then reconfigure the terminal address (Confer DC addressing procedure)
DS50: Nothing is written on the screen but it's enlightened	Idem	Press on the three right-hand side's buttons at the same time during a few seconds then reconfigure display address setting at 32.
Nothing occurs on the unit or an option disappeared	Possible problem of units' configuration	Check the instructions from 3811 to 3833 and reconfigure options if necessary.
DS50 & DC50: the message "No Link" appears	Problem of addresses' recognition	Disconnect the DS50 from the unit and then reconnect it.
All the units are extinct	Problem BM50 pLAN addressing	Disconnect then re-plug; disconnect each unit from the others then change all the pLAN addresses

Rooftops are generally placed on the roof but can also be installed in technical rooms. These units are very robust but minimum regular maintenance is required. Some moving parts in the units can suffer from wear and tear and must be checked regularly (belts). Other parts can get clogged by dirt carried in the air (filters) and must be cleaned or replaced.

These units are designed to produce cooled or heated air through the use of a refrigeration vapour compression system, it is therefore imperative to monitor the refrigeration circuit operating pressures and check the pipe-work for leaks.

The table below, details a possible maintenance plan, including the operations to be carried out and the periodicity at which they must be accomplished. It is recommended to follow such a plan to keep a rooftop unit in good working order. Regular maintenance of your rooftop will extend its operating life and reduce operating faults

<b>Symbols and Legend:</b>	
○	Operation which can be carried out by on-site maintenance technicians.
□	Operation which <b>must</b> be carried out by qualified refrigeration personnel, trained to operate on this type of equipment.

NOTE :

- Times are given for information purpose only and may vary depending on the unit size and type of installation.
- Coil cleaning must be carried out by qualified personnel using appropriate methods that won't damage the fins or the tubes.
- It is recommended to keep a minimum stock of common replacement parts in order to be able to carry out regular maintenance operations (i.e. filters). You can contact your local Lennox representative which can assist you in establishing a parts list for each type of equipment.
- The access ports to the refrigeration circuits **MUST** be leak checked every time gauges are connected to the service ports



Task	Operating mode	Monthly	Quarterly	6 monthly	Yearly B4 winter	Estimated Time (min)
Clean or replace filters: Disposable, or metal frame.	Replace filters with new ones if disposable. Vacuum clean or blow the dirt. Wash and dry carefully. Replace media if necessary Blocked filter will reduce the performance of the unit. <b>THE UNIT MUST NOT OPERATE WITHOUT FILTERS</b>	o				20
Visual check of the oil level	Visually check the oil level through the sight glass on the side of the compressor casing	o				2
Position check of the compressor crankcase heater.	Check the heating resistance is fitted properly and tight around the compressor body.	o				2
Belt tension check.	Check belt tension (Info in IOM) Replace belt if necessary.	o				10
Centrifugal fan bearings check	Isolate unit from the main power supply; Push the fan wheel manually and check for abnormal noises. Bearings are lubricated for life but may need replacement after 10000 hours	o				10
Check absorbed Amps	Check absorbed Amps on all three phases; compare with the nominal value given in the electrical wiring diagram.		□			15
Check Smoke detector	Start the unit. Trigger the smoke detector by moving a magnet around the detector head. Reset unit and control.		□			5
Check Climatic control, set-points and variables	Refer to the commissioning sheet; Check all set points are set according to this document.		□			15
Check clock settings	Check the time and date of the control		o			5
Check the position and tightness of refrigeration components	Check systematically all connections and fixings on the refrigeration circuit. Check for oil traces, eventually a leak test should be conducted. Check operating pressures correspond to the ones indicated on the commissioning sheet		□			30
Check Airflow rate safety switch (if fitted).	Shut down supply fan. The fault must be detected within 5 seconds.			o		
Check freeze protection on HWC				□		5
Check three way valve on HWC	Increase room set-point 10°C above the actual room temperature. Check operation of the piston. It must move away from the valve head. Reset the control.			□		5
Check economiser actuator operation	Check all fixings and transmission. Stop the unit using the control. The fresh air damper must close. Start the unit the fresh air damper should open			□		5
Check refrigeration 4way valve	With the unit running in cooling mode increase the room set-point temperature by 10°C. The unit should switch to heat pump mode. Reset the control.			□		5
Check tightness of all electrical connections	Power down the unit and check and tighten all screws, terminal and electric connections, taking a particular attention to the power lines and low voltage control wires			o		30

Check HP / LP safety switches	Install manifold gauges on the circuit to be checked. Shut down the axial fans and wait for the HP switch to shut down the compressor: 29bar (+1 / -0) auto-reset 22bar (+ - 0.7) Reconnect fans. Switch off the centrifugal supply fan and wait for the LP switch to cut out: 0.5bar (+ - 0.5) reset 1.5bar (+0.5).				□	15
Check outdoor fans and fan guards	Check the fan blades conditions and all fan guards and protections				○	5
Check position of all sensors	Check the good positioning and operation of all sensors of all sensors. Check the values given in the control system. Replace sensor if necessary				○	5
Check and clean if necessary all fresh air grilles	Check the fresh air grilles (if fitted). If dirty or damaged, remove them from unit and clean with high pressure water cleaner. Refit on unit once clean and dry.				○	5
Clean condensate drain, indoor and outdoor coils (following local regulations)	Visually check the coils for dirt. If not too dirty, cleaning with a light brush may be enough (WARNING: Fins and copper tubes are very fragile! Any damage WILL reduce the performances of the unit). If very dirty, deep industrial cleaning is required using de-greasing agents.(External contractors must be called).				○ / □	1h if cleaning
Check electric heater element for excessive corrosion	Isolate the unit; Pull the electric heater out of the heater module box and check the resistances of traces of corrosion; Replace resistance as required;				○	1h if replacement
Check anti-vibration mountings, for wear and tear.	Visually check anti-vibration mountings on compressors and centrifugal fan. Replace if damaged.				○	1h if replacement
Check refrigeration circuit for traces of acid in the oil	Take a sample of oil from the refrigeration circuit.				□	
Check Glycol concentration in the HWC circuit	Check the glycol concentration in the pressurised water circuit. ( a concentration of 30% gives a protection down to aprox. -15°C) check the circuit pressure				□	30
Check defrost cycle with 4-way valve inversion.	Switch the unit to heat pump mode. Change the set point to obtain the standard defrost mode and reduce the cycle time to the min value. Check the operation of the defrost cycle.				□	30
Gas burner module check for corrosion	Pull out the burner to access the tubes (refer to Gas burner section in the IOM)				□	30
Sweeping and cleaning the gas burner	Clean the in-shot burners and the blower wheel lightly with a brush. Sweep the flue and flue box. Wipe-off the dust from the housing of the motor. Clean combustion air inlet louvers Pull-out baffles from the tubes, sweep the tubes <b>CHECK FLUE BOX GASKET</b>				□	30
Gas supply pressures / connections checks	refer to Gas burner section in the IOM for details				□	15
Gas regulation valve settings	refer to Gas burner section in the IOM for details				□	30
Check gas burner safety switches	refer to Gas burner section in the IOM for details				□	30

## **TERMS AND CONDITIONS**

In the absence of any other written agreement, the guarantee shall only apply to design faults which occur within a 12 month period (warranty period).

The warranty period starts on the date of commissioning and at the latest six months after the delivery of the Rooftop.

## **ANTI-CORROSION WARRANTY**

### **10 year warranty terms and conditions for corrosion to the Rooftop casing:**

Lennox shall guarantee the casing of its Rooftop units manufactured since May 1991 against corrosion for 10 years commencing from the date of delivery of the material.

The warranty shall not apply in the following cases:

1. If the corrosion of the casing is caused by external damage to the protective layer such as scratches, projections, abrasion, impacts etc...
2. If the casing is not kept continually clean in the course of maintenance work or by a specialist company,
3. If the casing is not cleaned and maintained in accordance with regulations,
4. If the Rooftop units are installed on a site or in an environment which is known to be corrosive, unless a special protective coating has been applied by the owner for these applications, which has been recommended by a competent body not linked to the owner and after carrying out a study of the site.
5. Nevertheless the LENNOX coating is highly resistant to corrosion, the warranty will not be applied for rooftop installed at less than 1000m away from the sea

Note: With the exception of the casing, the rest of the machine is covered by the warranty of our general terms of sale.

## **DO NOT CONFUSE THE WARRANTY WITH MAINTENANCE**

The warranty will only apply if a maintenance contract has been signed, starting from the date of commissioning, and if the maintenance contract has actually been performed.

The maintenance contract must be made with a specialist, competent company.

The sole effect of any repair, modification or replacement of an item during the warranty period must be to extend the material's warranty period.

Maintenance must be carried out in accordance with regulations.

If a spare part is supplied after the expiry of the warranty period, it shall be guaranteed for a period equal to the initial warranty period and will be subject to the same conditions.

We recommend for a contract four inspections per year (every three months), before the start of each season, in order to check the operation of the equipment in the various operating modes.





Site Industriel de LONGVIC  
ZI de LONGVIC - BP 60  
21902 LONGVIC - France

Téléphone : +33 (0)3 80 77 41 41  
Fax : +33 (0)3 80 66 66 35

**DECLARATION DE CONFORMITE DU CONSTRUCTEUR**  
**Conformément**  
**à la Directive européenne « Equipement sous pression » 97/23/CE,**

**CE CONFORMITY DECLARATION**  
**As defined by**  
**« Pressure equipment » Directive 97/23/EC,**

**LGL France SA, ZI Les Meurières - 69780 Mions - France**

La société soussignée certifie sous sa seule responsabilité que l'ensemble de nos fabrications de roof top désignés par les types suivants :

*The company hereby declare, under its own responsibility, that the entire roof top range which designations are :*

**FCK FHK FGK FDK**  
**FXK**  
**FCM FHM FGM FDM**  
**BCK BHK BGK BDK**

Qui contiennent des fluides frigorigènes classés en groupe 2 (R407C et R410A),  
*Which are containing refrigerating fluids classified in group 2 (R407C & R410A),*

Sont conformes aux dispositions de la Directive « Equipements sous pression », 97/23/CE  
*Is in compliance with the requirements of « Under pressure equipments » directive, 97/23/EC :*

Catégorie Category : II

Module d'évaluation Evaluation Module : D1

Organisme notifié. *Notified body* : Bureau VERITAS

17 bis, place des reflets - La DEFENSE 2 - 92400 Courbevoie.

Sont conformes aux dispositions de la Directive - *Are in compliance with the requirements of*

« Machines », 98/37/CE - « Machinery », 98/37/EC

« Basse Tension », 73/23/CEE modifiée - « Low voltage », 73/23/EEC amended

« CEM », 89/336/CEE - « EMC », 89/336/EEC

« Appareils à gaz », 90/396/CEE modifiée - « Gas machines », 90/396/EEC amended

Ces produits sont fournis avec un marquage de conformité.

*The products are provided with a marking of conformity.*

Date : 12/05/06

**E. MOUTON**  
**Directeur du site de Longvic**

LENNOX France, Division climatisation de LGL France

Rége local LGL France - ZI Les Meurières - BP 60 - 21902 LONGVIC - France

Société anonyme au capital de 300 015 328F - RCS (YON) 030 528 115 - N° IDENTIFICATION TVA FR 66 300 528 115 - APE 2620



Agence certifiante  
AFAQ AFNOR Certification  
11, Avenue Forbes de Provençale  
92071 SAINT-GENIS LA PLANE Cedex  
☎ (33) 1 43 15 20 20 - Fax : (33) 1 43 15 25 41  
Site Internet : <http://www.afaqafnor.fr>

Marque NF – Matériels de Détection Incendie



LA SECURITE CERTIFIEE  
Organisation reconnue  
L'Etat a reconnu l'existence officielle de la norme NF S 61-961  
☎ (33) 1 43 15 20 20 - Fax : (33) 1 43 15 25 41  
Site Internet : <http://www.cnmis.com>

**CERTIFICAT DE DROIT D'USAGE DE LA MARQUE NF  
(LICENCE)**

N° DROIT D'USAGE  DAD 013 J0	La Société :  Pour son usine de	FINSECUR 32, rue Paul LESCOUP 92000 NANTERRE FINSECUR	Date de fin de validité : 31.03/2007
Correspondant C.N.M.I.S. SAS José CAMPO Tél : 01 53 89 00 48 Fax : 01 45 63 40 63			
N° Dossier C.N.M.I.S. SAS 0303018			MODIFICATIONS
Conformité aux normes NF S 61-961			

Est autorisé à apposer la marque NF sur le matériel désigné ci-après

Désignation technique du matériel	Détecteur Autonome Déclencheur
Désignation commerciale	LOTUS EW2C
Caractéristiques certifiées	Type 2
Éléments sensibles	1 TYPE E 4 (Les autres caractéristiques sont reprises dans les rapports d'essai)
Ce matériel fonctionne avec	Voir liste des matériels associés
Références et date des rapports d'essai	DH 03 01 76 du 14 Mai 2003
Fonctions supplémentaires	Voir rapports référencés ci-dessus

*N.B : Cette décision dispense le titulaire de la présentation des Procès Verbaux d'essai (incluant les rapports d'essais) de conformité aux normes du matériel ci-dessus.*



PARIS, le vendredi 14 avril 2006  
Par mandat d'AFAQ AFNOR Certification  
Le C.N.M.I.S. SAS

Le Directeur Général  
Denis CLUZEL

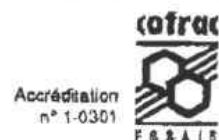

Ce certificat accorde et reconnaît aux certifiés suivants, au date de validité qui est conditionnée sous réserve des contrôles effectués par AFAQ AFNOR Certification et/ou le C.N.M.I.S. SAS qui peuvent perdre toute validité conformément aux Règles Générales de la Marque NF et au Décret n° 8275. Ce certificat atteste que les produits désignés sont certifiés conformes au référentiel technique du Décret n° 8275 et que le titulaire qualifié de la certifiée a été déclaré selon ce même Décret. Il s'engage au nom de AFAQ AFNOR Certification et le C.N.M.I.S. SAS quant à la conformité réglementaire de l'installation dans laquelle les produits objets de ce certificat seront utilisés.

**CSTB***le futur en construction*DÉPARTEMENT SÉCURITÉ  
STRUCTURES ET FEU  
Réaction au feu

## PROCÈS-VERBAL DE CLASSEMENT DE RÉACTION AU FEU D'UN MATÉRIAU

Prévu à l'article 88 de l'Arrêté du Ministère de l'Intérieur du 30 juin 1983,  
modifié par l'arrêté du 28 août 1991 et l'arrêté du 27 novembre 1991  
Laboratoire pilote agréé du Ministère de l'Intérieur (arrêté du 05/02/59, modifié)

**N° RA02-0505**

Valable 5 ans à compter du 20 décembre 2002

**Matériau présenté par** : La Société SAINT GOBAIN ISOVER  
Les Miroirs  
18 avenue d'Alsace  
94000 COURBEVOIE

**Marque commerciale** : CLIMAVER 274 panneau nu ou PRIMITIF 2VM0  
CLIMAVER 274 2VVN

**Description sommaire** :  
Feutre rigide en laine de verre (fibres de verre liées par une résine synthétique  
thermodurcissable) revêtu sur la face apparente d'un voile de verre noir et sur l'autre  
face :

- d'un voile de verre jaune renforcé par des fils de verre pour le produit référencé  
CLIMAVER 274 panneau nu ou PRIMITIF 2VM0.
- d'un voile de verre noir identique, pour le produit référencé CLIMAVER 274 2VVN.

Masse surfacique nominale : 1,7 kg/m<sup>2</sup> environ. Épaisseur nominale : 25 mm.

**Nature de l'essai** : Essai par rayonnement  
Mesure du Pouvoir Calorifique Supérieur

Classement :

**MO**

**Durabilité du classement (Annexe 22) :** Non limitée a priori  
compte tenu des critères résultant des essais décrits dans le rapport d'essais N° RA02-0505 annexé.

Le classement indiqué ne préjuge pas de la conformité des matériaux commercialisés aux échantillons soumis aux  
essais et ne saurait en aucun cas être considéré comme un certificat de qualification tel que défini par la loi. Cette  
conformité peut être attestée par les certificats de qualification reconnus par le ministère chargé de l'Industrie, et  
notamment par la marque NF - Réaction au Feu.

Champs/Marne le : 20 décembre 2002

Le technicien responsable de l'essai

Le chef du laboratoire Réaction au Feu

Nicolas ROURE

Martial BONHOMME

Sont seules autorisées les reproductions intégrales du présent procès-verbal de classement ou de l'ensemble procès-verbal de  
classement et rapport d'essais annexé.

PARIS - MARNE-LA-VALLÉE - GRENOBLE - NANTES - SOPHIA ANTIPOLIS  
CENTRE SCIENTIFIQUE ET TECHNIQUE DU BÂTIMENT

84, avenue Jean-Baptiste - Champs-sur-Marne - BP 2 - F-77421 Marne-la-Vallée Cedex 2  
Tél. : 01 54 88 82 82 - Fax : 01 54 88 84 79 - site web : feu.cstb.fr



DEPARTEMENT SECURITE  
STRUCTURES ET FEU  
Réaction au feu



## PROCÈS-VERBAL DE CLASSEMENT DE RÉACTION AU FEU D'UN MATÉRIAU

Selon l'arrêté du 21 novembre 2002 relatif à la réaction au feu des produits de construction et d'aménagement  
Laboratoire: pilote agréé du Ministère de l'Intérieur (arrêté du 05/02/99, modifié)

**N° RA05-0491**

Valable 5 ans à compter du 30 novembre 2005

Matériau présenté par : SAINT GOBAIN ISOVER  
18 Avenue d'Alsace  
Les Miroirs  
92400 COURBEVOIE  
FRANCE

Marque commerciale : CLIMAVER 202 - FIB-AIR ISOL

### Description sommaire :

Feutre en laine de verre (fibres de verre liées par une résine synthétique thermodurcissable), revêtu sur une face d'une feuille d'aluminium renforcée d'une grille de verre tri directionnelle. Le complexe aluminium est contrecollé à l'aide d'une colle polyéthylène.

Masse volumique nominale de la laine de verre : 30 kg/m<sup>3</sup>.

Epaisseurs nominales : 25 à 50 mm.

Masse surfacique nominale du complexe : 103 g/m<sup>2</sup>.

Nature de l'essai : Essai par rayonnement avec joint simulé suivant avis CECMI en date du 08 avril 1993.  
Mesure du Pouvoir Calorifique Supérieur

Classement : **MO** valable pour toute application pour laquelle le produit n'est pas soumis au marquage CE

Durabilité du classement (Annexe 2 – Paragraphe 5) : Non limitée a priori  
compte tenu des critères résultant des essais décrits dans le rapport d'essais N° RA05-0491 annexé.

Ce procès verbal atteste uniquement des caractéristiques de l'échantillon soumis aux essais et ne préjuge pas des caractéristiques de produits similaires, il ne constitue donc pas une certification de produits au sens de l'article L 115-27 du code de la consommation et de la loi du 3 juin 1994.

Champs-sur-Marne, le 30 novembre 2005

Le Technicien Responsable de l'essai

Le Chef du Laboratoire Réaction au Feu

Nicolas ROURE

Martial BONHOMME

Sont seules autorisées les reproductions intégrales du présent procès-verbal de classement ou de l'ensemble procès-verbal de classement et rapport d'essais annexé.

PARIS - MARNE-LA-VALLÉE - GRENOBLE - NANTES - SOPHIA ANTIPOLIS  
CENTRE SCIENTIFIQUE ET TECHNIQUE DU BÂTIMENT

34, avenue Joffre - Champs-sur-Marne - BP 2 - F-77417 Marne-la-Vallée Cedex 2  
Tél : 01 64 63 94 12 - Fax : 01 64 63 94 79 - E-mail : dist.cstb.fr





DEPARTEMENT SECURITE  
STRUCTURES ET FEU  
Réaction au feu



## PROCÈS-VERBAL DE CLASSEMENT DE RÉACTION AU FEU D'UN MATÉRIAU

Selon l'arrêté du 21 novembre 2002 relatif à la réaction au feu des produits de construction et d'aménagement  
Laboratoire pilote agréé du Ministère de l'Intérieur (arrêté du 05/02/99, modifié)

**N° RA05-0065**

Valable 5 ans à compter du 17 février 2005

**Matériau présenté par** : HOLLINGSWORTH & VOSE EUROPE  
Ikaroslaan 19  
1930 ZAVENTEM  
BELGIQUE

**Marque commerciale** : A100GN / HF 6165 S

**Description sommaire** : Média filtrant en fibres de verre liées par une résine acrylique.  
Masse surfacique nominale : 63 g/m<sup>2</sup>.  
Epaisseur nominale : 0,6 mm.  
Coloris : blanc.

**Nature de l'essai** : Essai au Brûleur Électrique

**Classement** :

**M1**

**Durabilité du classement (Annexe 2 – Paragraphe 5)** : Non limitée a priori (média filtrant non régénérable)  
compte tenu des critères résultant des essais décrits dans le rapport d'essais N° RA05-0065 annexé.

Ce procès verbal atteste uniquement des caractéristiques de l'échantillon soumis aux essais et ne préjuge pas des caractéristiques de produits similaires. Il ne constitue donc pas une certification de produits au sens de l'article L 115-27 du code de la consommation et de la loi du 3 juin 1994.

Champs-sur-Marne, le 17 février 2005

Le Technicien Responsable de l'essai

Olivier BRAULT

Le Chef du Laboratoire Réaction au Feu

Martial BONHOMME

Sont seules autorisées les reproductions intégrales du présent procès-verbal de classement ou de l'ensemble procès-verbal de classement et rapport d'essais annexé.

PARIS - MARNE-LA-VALLÉE - GRENOBLE - NANTES - SOPHIA ANTIPOLIS  
CENTRE SCIENTIFIQUE ET TECHNIQUE DU BÂTIMENT

84, avenue Jean-Jaurès - Champs-sur-Marne - BP 2 - F-77447 Marne-la-Vallée Cedex 2  
Tél. : 01 64 68 84 12 - Fax : 01 64 68 84 79 - E-mail : dsst.cstb.fr

**CSTB**

le futur en construction

DEPARTEMENT SECURITE  
STRUCTURES ET FEU

Réaction au feu

cofrac

Accréditation  
n° 1-0301

## PROCÈS-VERBAL DE CLASSEMENT DE RÉACTION AU FEU D'UN MATÉRIAU

Selon l'arrêté du 21 novembre 2002 relatif à la réaction au feu des produits de construction et d'aménagement  
Laboratoire pilote agréé du Ministère de l'Intérieur (arrêté du 05/02/59, modifié)

**N° RA06-0191**

Valable 5 ans à compter du 02 juin 2006

**Matériau présenté par** : CAMFIL SAS  
Usine de Saint-Martin Longueau  
ZI route d'Avrigny  
60722 PONT-SAINTE-MAXENCE  
FRANCE

**Marque commerciale** : G 300

**Description sommaire** : Media filtrant composé de fibres 100% polyester  
non ignifugées.  
Epaisseur nominale : 20 mm.  
Masse surfacique nominale : 198 g/m<sup>2</sup>.  
Coloris : blanc.

**Nature de l'essai** : Essai au Brûleur Électrique  
Essais Complémentaires

Classement :

**M1**

**Durabilité du classement (Annexe 2 – Paragraphe 5)** : Non limitée a priori  
compte tenu des critères résultant des essais décrits dans le rapport d'essais N° RA06-0191 annexé.

Ce procès verbal atteste uniquement des caractéristiques de l'échantillon soumis aux essais et ne préjuge pas des caractéristiques de produits similaires. Il ne constitue donc pas une certification de produits au sens de l'article L. 115-27 du code de la consommation et de la loi du 3 juin 1994.

Champs-sur-Marne, le 02 juin 2006

Le Technicien Responsable de l'essai

Le Chef du Laboratoire Réaction au Feu

Gildas CREACH

Bruce LE MADEC

Sont seules autorisées les reproductions intégrales du présent procès-verbal de classement ou de l'ensemble procès-verbal de classement et rapport d'essais annexé.

PARIS - MARNE-LA-VALLÉE - GRENOBLE - NANTES - SOPHIA ANTIPOLIS  
CENTRE SCIENTIFIQUE ET TECHNIQUE DU BÂTIMENT

84, avenue Jean-Jaurès - Champs-sur-Marne - BP 2 - F-77447 Marne-la-Vallée Cedex 2  
Tél. : 01 64 68 84 12 - Fax : 01 64 68 84 79 - E-mail : dsf.cstb.fr



# Certificat Certificate

(« Gas appliances » 90/398 EEC Directive)  
(Directive 90/398/CEE « Appareils à gaz »)

Numéro : **1312BL3276** (rev. 4)

**CERTIGAZ**, after examination and verifications, certifies that the appliance :  
**CERTIGAZ**, après examen et vérifications, certifie que l'appareil :

- **Manufactured by :** **LENNOX FRANCE**  
*Fabriqué par :* **Z.I. LONNOYR - RP 60**  
**F-21602 LONNOYR - CFFRFX**
- **Trade mark and model(s) :**  
*Marque commerciale et modèle(s) :*

<b>LENNOX</b>
---------------

  - > GM 180/4
  - > FG-F60 - FG-F120 - FG-G120
  - > FG-H180 - FG-H180 - FG-H240
  - > FG-FM60 - FG-FM120 - FG-GM120
- **Kind of the appliance :**  
*Genre de l'appareil :* **GAS AIR HEATER UNIT FOR ROOF TOP (B22)**  
**MUR À HAUT L'HAUTAGE POUR CLIMATISATION DE TOITURE (B22)**
- **Type designation :**  
*Désignation du type :* **GM 180/4**

Destination countries <i>Pays de destination</i>	Pressures (mbar) <i>Pressions (mbar)</i>	Categories <i>Catégories</i>
FR	20/25 ; 37	II2E3P
DE	20/25 ; 37	II2E3 ; III2
PT-GR-ES-GR	20 ; 37	II2H3P
IE	20 ; 50	IEE ; I3P
DK-SE-IT-CZ-EE-PT-IT-V	20	IEH
NL	38 ; 37-50	II2L3P
HU	38 ; 50	I3P
CY-MT	50	I3P
SI-SK	20 ; 37 ou 50	II2H3P
PL	20	IEE
PL	38	I3P
SE	37	IEE
CZ	20 ; 37	II2H3P

is in conformity with essential requirements of a Gas appliances, a directive 90/398/EEC.  
est conforme aux exigences essentielles de la directive "Appareils à gaz" 90/398/CEE.

**CERTIGAZ**  
**Le Directeur Général**

**Yannick ONFROY**

Paris le : 28 Juin 2006



Rev. 4 - 1996/05/09 DU 2006/06/01

CERTIGAZ SAS - 10 rue de Courcelles - F-75002 PARIS - www.certigaz.fr

Bureau Veritas S.A. is a Notified



Body under the number 0062

**BUREAU  
VERITAS**

**ATTESTATION D'APPROBATION DE SYSTEME DE QUALITE  
CERTIFICATE OF QUALITY SYSTEM APPROVAL**

**N° CE-PED-D1-LNX 001-05-FRA-revA**

BUREAU VERITAS S.A., agissant dans le cadre de sa notification (numéro d'organisme notifié 0062), atteste que le système de qualité appliqué par le fabricant pour l'inspection finale et les essais des équipements sous pression identifiés ci-après, a été examiné selon les prescriptions du module D1 de l'annexe III de la directive "Equipements sous pression" N° 97/23/CE et est conforme aux dispositions correspondantes de la directive.

BUREAU VERITAS S.A., acting within the scope of its notification (notified body number 0062), attests that the quality system operated by the manufacturer for final inspection and testing of the pressure equipment identified hereunder has been examined against the provisions of annex III, module D1, of the Pressure Equipment directive n° 97/23/EC, and found to satisfy the provisions of the directive which apply to it.

Fabricant (Nom) / Manufacturer (Name): **LENNOX France**  
 Adresse / Address: **2 Rue Lavoisier, 21002 LONGVIC, FRANCE**  
 Marque commerciale / Branding name: **LENNOX**  
 Description des équipements / Equipment description: **Climatiseurs de type "ROOFTOP"**  
 Identification des équipements concernés (Voir en annexe le cas échéant) / Identification of equipment concerned (Not attached where necessary): **Voir liste en annexe**  
 Motif de la révision: **Extension famille**  
 Cette attestation est valable jusqu'au (MM/JJ/AAAA) / This certificate is valid until (MM/DD/YYYY): **06/13/2008**

Le maintien de l'approbation est soumis à la réalisation par le Bureau Veritas des audits, essais et vérifications selon le contrat signé par le fabricant et le Bureau Veritas.  
 The approval is conditional upon the surveillance audits, tests and verifications to be carried out by Bureau Veritas as per the provisions stated in the agreement signed by both the manufacturer and Bureau Veritas.

Cette attestation est nulle et le fabricant supportera seul les conséquences de son utilisation, si les apparances - données par le fabricant lors de la demande d'intervention - en matière (a) d'application de son système qualité approuvé, (b) de conformité de son équipement au type et (c) d'inspection et d'essais des produits fins se révélant inexécutes et, de manière générale, si le fabricant ne respecte pas l'une ou l'autre des obligations mises à sa charge par la directive n° 97/23/CE du 29 mai 1997 telle que transposée dans (sa) droit(s) national(aux) applicable(s).

This certificate shall be deemed to be void and the manufacturer shall alone bear any consequences arising to its use, where the manufacturer fails to comply with his undertakings as per the agreement in respect of (a) implementation of the approved quality system, (b) conformity of the equipment with the type and (c) inspection and tests on the final product, and generally where the manufacturer fails in particular to comply with any of his obligations under directive n° 97/23/EC of 29 May 1997 as transposed in the applicable law(s).

Etabli à / Made at	Le (MM/JJ/AAAA) / On (MM/DD/YYYY)	Signé par / Signed by	Signature / Signature
DIJON	07/05/2008	Christian Boitelle	

[Code d'enregistrement / Registration code: 2006/201 13 12248P]

La présente attestation est soumise aux Conditions Générales de Service de Bureau Veritas jointes à la demande d'intervention signée par le demandeur. / This certificate is subject to the terms of Bureau Veritas General Conditions of Service attached to the agreement signed by the applicant.

Bureau Veritas S.A. is a Notified



Body under the number 0062

**BUREAU  
VERITAS**

**ANNEXE à l'attestation d'approbation de système de qualité :**  
*ANNEX to the certificate of quality system approval*

**N° CE-PED-D1-LNX 001-05-FRA-revA**

**Liste des équipements concernés**  
*List of the concerned equipment*

**Produits standardis**

<b>Gammes</b>	<b>Modèles</b>
<b>FLEXY:</b>	
FCA, FHA, FGA, FDA	50 à 200
FGK, FHK, FGK, FDK	50 à 300
FXA, FXK (4 volets)	25 à 200
Flexy (à condensation)	80 à 190
<b>FLEXY 2 (R410 A):</b>	
FCM, FHM, FQM, FDM	85 à 230
<b>BALTIC:</b>	
Version mono-circuit et bi-circuit,	
BCK, BHK, BGK, BDK	020-025-030-035-040-045-050-060-070



[www.lennox europe.com](http://www.lennox europe.com)

Due to Lennox's ongoing commitment to quality, the Specifications, Ratings and Dimensions are subject to change without notice and without incurring liability.

Improper installation, adjustment, alteration, service or maintenance can cause property damage or personal injury.

Installation and service must be performed by a qualified installer and servicing agency.



FLEXYII-IOM-0308-E