

# LCE

**Installation, use and maintenance manual**



**COOLING ONLY AND HEAT PUMP VERSIONS**



# USER MANUAL



## CONTENTS

<b>1</b>	<b>THE SERIES</b>	<b>6</b>
<b>2</b>	<b>FIELD OF APPLICATION</b>	<b>7</b>
<b>3</b>	<b>GENERALITIES</b>	<b>7</b>
<b>4</b>	<b>INSPECTION, CONVEYANCE, SITING</b>	<b>9</b>
4.1	INSPECTION	9
4.2	LIFTING AND CONVEYANCE	9
4.3	UNPACKING	10
4.4	SITING	10
<b>5</b>	<b>INSTALLATION</b>	<b>11</b>
5.1	INSTALLATION CLEARANCE REQUIREMENTS	11
5.2	GENERAL GUIDELINES FOR PLUMBING CONNECTIONS	12
5.3	WATER CONNECTION TO THE EVAPORATOR	13
5.4	PROCEDURE FOR FILLING THE STORAGE RESERVOIR	14
5.5	SAFETY DEVICES ON THE HIGH PRESSURE SIDE	15
<b>6</b>	<b>ELECTRICAL CONNECTIONS</b>	<b>15</b>
6.1	GENERALITIES	15
6.2	ELECTRICAL CONNECTIONS DIFFERENTIAL WATER PRESSURE SWITCH	16
6.3	ELECTRIC CONNECTIONS OF THE CIRCULATION PUMP	16
6.4	REMOTE CONTROLS	17
6.5	REMOTE SUMMER-WINTER SWITCHING	17
<b>7</b>	<b>STARTING UP</b>	<b>18</b>
7.1	PRELIMINARY CHECKS	18
7.2	STARTING OPERATION	19
7.3	CHECKS DURING OPERATION	20
7.4	CHECKING THE REFRIGERANT LEVEL	20
7.5	EXPANSION VALVE	21
7.6	STOPPING THE UNIT	22
<b>8</b>	<b>OPERATING LIMITS</b>	<b>22</b>
8.1	WATER FLOW TO EVAPORATOR	22
8.2	CHILLED WATER TEMPERATURE	23
8.3	OUTDOOR AIR TEMPERATURE	23
8.4	OPERATION WITH WATER AT LOW TEMPERATURES	23
<b>9</b>	<b>SETTING OPERATING PARAMETERS</b>	<b>23</b>
9.1	GENERALITIES	23
9.2	MAXIMUM PRESSURE SWITCH	24
9.3	MINIMUM PRESSURE SWITCH	24
9.4	SERVICE THERMOSTAT	24

9.5	ANTIFREEZE THERMOSTAT	25
9.6	ANTI-RECYCLE TIMER	25
9.7	OIL DIFFERENTIAL PRESSURE SWITCH	25
<b>10</b>	<b>ROUTINE MAINTENANCE AND CHECKS</b>	<b>25</b>
10.1	WARNINGS	25
10.2	GENERALITIES	26
10.3	REPAIRING THE COOLING CIRCUIT	26
10.4	TIGHTNESS TEST	26
10.5	HARD VACUUM AND DRYING OF THE COOLING CIRCUIT	27
10.6	CHARGING WITH R410A REFRIGERANT	27
10.7	ENVIRONMENTAL PROTECTION	28
<b>11</b>	<b>RETIRING THE UNIT</b>	<b>28</b>
<b>12</b>	<b>TROUBLESHOOTING</b>	<b>29</b>
<b>13</b>	<b>WATER PRESSURE DROPS</b>	<b>32</b>
13.1	PRESSURE DROPS IN EVAPORATOR	32
13.2	PRESSURE DROPS IN HEAT RECUPERATOR	32
<b>14</b>	<b>SUMMARY TECHNICAL DATA</b>	<b>33</b>
<b>15</b>	<b>SUMMARY TABLE OF WEIGHTS</b>	<b>35</b>
15.1	TOTAL STD WEIGHTS C-H	36
15.2	WEIGHTS OF HYDRONIC MODULES C-H	38
15.3	PUMPING AND STORAGE SYSTEMS	42

### **Declaration of conformity**

The declaration of conformity is individually appended to the documents accompanying the unit, normally placed inside the electrical enclosure.

# 1 THE SERIES

Fluid chillers and heat pumps designed to cool water or mixtures of water and an antifreeze agent, intended for civil air conditioning and industrial cooling systems. LCE chillers, available in versions with different acoustic designs (“S”, “L”, “Q”) and cooling circuit architectures (Efficiency pack 1, 2, 4), cover a range of cooling capacities from 44.4 to 313.9 kW, calculated with reference to standard test conditions of water 12/7° - air entering the finned block heat exchangers 35°C.

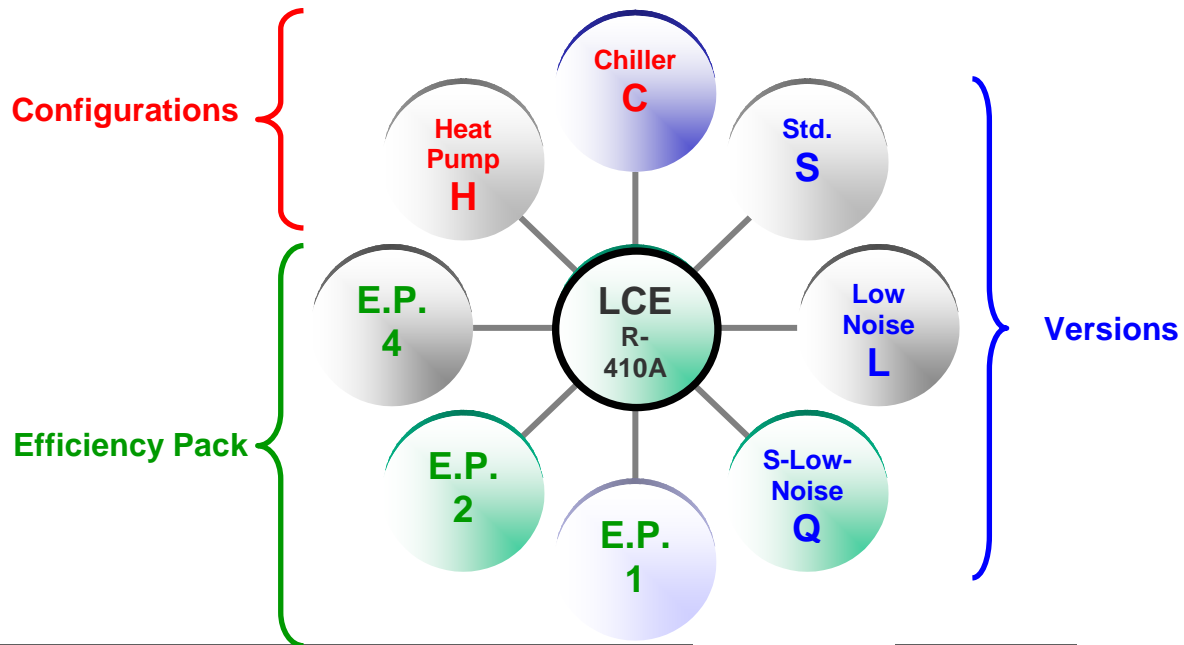

Example of product code composition::

	Size + eff. pack	configuration	version
<b>Sigla completa macchina</b>	L C E	104	H Q
<b>Nome commerciale</b>	L C E		
<b>Modello</b>	104		
<b>Funzionamento</b>	H		
refrigeratore	C		
pompa di calore	H		
<b>Versione</b>	Q		
standard	S		
silenziosa	L		
super-silenziosa	Q		

**Configurations:** Chiller – cooling only → “C”  
Heat pump → “H”

**Versions:** Standard version → “S”  
Low noise version – for a low noise impact → “L”  
Super low noise version - for an extremely low noise impact → “Q”

**Efficiency Packs:** Efficiency pack 1 → 1 compressor per circuit  
Efficiency pack 2 → 2 tandem compressors on 1 circuit  
Efficiency pack 4 → 2 tandem compressors on 2 circuits

Below is a list of all possible models, broken down by efficiency pack :

efficiency pack 1	efficiency pack 2	efficiency pack 4	Approximate cooling capacity for "cooling only" version [kW]
-	LCE042CS/CL/CQ	-	48
-	LCE042HS/HL/HQ	-	48
-	LCE052CS/CL/CQ	-	53
-	LCE052HS/HL/HQ	-	53
-	LCE062CS/CL/CQ	-	63
-	LCE062HS/HL/HQ	-	63
-	LCE072CS/CL/CQ	-	70
-	LCE072HS/HL/HQ	-	70
-	LCE082CS/CL/CQ	-	77
-	LCE082HS/HL/HQ	-	77
LCE091CS/CL/CQ	LCE092CS/CL/CQ	LCE094CL/CQ	92
LCE091HS/HL/HQ	LCE092HS/HL/HQ	LCE094HL/HQ	92
LCE101CS/CL/CQ	LCE102CS/CL/CQ	LCE104CL/CQ	103
LCE101HS/HL/HQ	LCE102HS/HL/HQ	LCE104HL/HQ	103
LCE121CS/CL/CQ	LCE122CS/CL/CQ	LCE124CS/CL/CQ	125
LCE121HS/HL/HQ	LCE122HS/HL/HQ	LCE124HS/HL/HQ	125
LCE141CS/CL/CQ	LCE142CS/CL/CQ	LCE144CS/CL/CQ	138
LCE141HS/HL/HQ	LCE142HS/HL/HQ	LCE144HS/HL/HQ	138
LCE161CS/CL/CQ	LCE162CS/CL/CQ	LCE164CS/CL/CQ	155
LCE161HS/HL/HQ	LCE162HS/HL/HQ	LCE164HS/HL/HQ	155
-	-	LCE174CS/CL/CQ	162
-	-	LCE174HS/HL/HQ	162
-	-	LCE194CS/CL/CQ	187
-	-	LCE194HS/HL/HQ	187
-	-	LCE214CS/CL/CQ	209
-	-	LCE214HS/HL/HQ	209
-	-	LCE244CS/CL/CQ	237
-	-	LCE244HS/HL/HQ	237
-	-	LCE274CS/CL/CQ	271
-	-	LCE274HS/HL/HQ	271
-	-	LCE294CS/CL/CQ	296
-	-	LCE294HS/HL/HQ	296
-	-	LCE324CS/CL/CQ	314
-	-	LCE324HS/HL/HQ	314

## 2 FIELD OF APPLICATION

These machines are designed to cool-heat water and solutions containing up to 35% glycol (percentage by weight) in civil, industrial and technological air-conditioning systems.

They must be used in observance of the operating limits specified in this manual; failure to comply with said limits will invalidate the warranties provided in the contract of sale.

## 3 GENERALITIES

- When installing or servicing the chiller, you must strictly follow the rules provided in this manual, comply with the directions on the units and take all such precautions as are necessary.
- The fluids under pressure in the cooling circuit and the presence of electrical components may cause hazardous situations during installation and maintenance work.



Therefore, only qualified personnel may perform any kind of work on the unit.

- THE UNIT MUST BE STARTED UP FOR THE FIRST TIME EXCLUSIVELY BY QUALIFIED PERSONNEL AUTHORISED BY LENNOX S.P.A. (SEE ATTACHMENT).
- FAILURE TO COMPLY WITH THE RULES PROVIDED IN THIS MANUAL OR ANY MODIFICATION MADE TO THE UNIT WITHOUT PRIOR AUTHORISATION WILL RESULT IN THE IMMEDIATE INVALIDATION OF THE WARRANTY.



**Warning: Before performing any kind of work on the unit, make sure it has been disconnected from the power supply.**



## 4 INSPECTION, CONVEYANCE, SITING

### 4.1 INSPECTION

On receiving the unit, check that it is perfectly intact: the chiller left the factory in perfect conditions; immediately report any signs of damage to the carrier and note them on the Delivery Slip before signing it. Check, in particular, that the fins of the finned block heat exchangers are not bent and have not undergone impacts that may have impaired the system's tightness under pressure.

Lennox S.p.A. or its Agent must be promptly notified of the entity of the damage.

The Customer must submit a written report describing every significant sign of damage.

- commissioning report,
- 4 wiring diagram,
- warranty certificate and list of authorised service centres,
- check the integrity of the documents accompanying the unit and of this manual.

### 4.2 LIFTING AND CONVEYANCE

While the unit is being unloaded and positioned, utmost care must be taken to avoid abrupt or violent manoeuvres. The unit must be handled carefully and gently: avoid using machine components as anchorages when lifting or moving it.

The unit should be lifted using  $\text{Ø}1\frac{1}{2}$ " GAS steel pipes at least 3mm thick, to be inserted in the round holes provided on the base side members (see fig. below) and identified by means of stickers. The pipes, which should protrude by at least 250-300mm on every side, must be slung with ropes of equal length secured to the lifting hook (provide stops at the ends of the pipes to prevent the ropes from slipping off due to the weight).

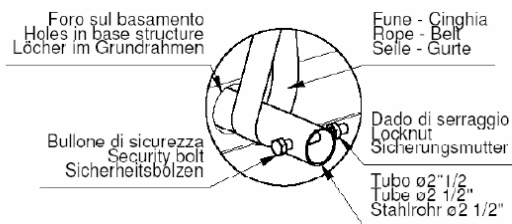

Use ropes or belts long enough to extend beyond the height of the unit and place spacer bars and boards on the top of the unit to avoid damaging the sides and top of the unit itself. The rectangular holes are provided for the attachment of vibration damping supports (optional).



**Warning: In all lifting operations make sure that the unit is securely anchored in order to prevent accidental falls or overturning.**

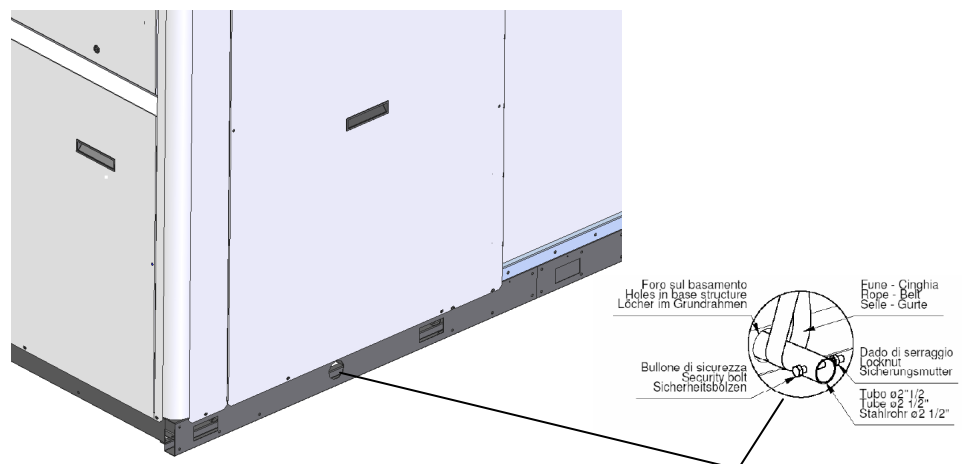

### 4.3 UNPACKING

The packing must be carefully removed to avoid the risk of damaging the unit. Different packing materials are used: wood, cardboard, nylon etc.

It is recommended to keep them separately and deliver them to suitable waste disposal or recycling facilities in order to minimise their environmental impact.

**Warning:** if the unit is supplied with a pump or pumps and/or storage reservoir, you will find the expansion tank packaged in the fan compartment; it must be fixed to the pump intake pipe, where a "TEE" is fixed so as to form a tight seal, or on the tank itself. Remove the cap and screw in the expansion tank (operation to be performed by qualified personnel), check the pre-fill pressure (0.5 - 1.0 bars-r) before filling the water circuit and starting up the chiller.

**Warning:** the size of the expansion tank will depend both on the volume of water contained in the system and the water temperature range ; always check the tank capacity in relation to the water content of the system.

### 4.4 SITING

You should bear in mind the following aspects when choosing the best site for installing the unit and the relative connections:

- size and origin of water pipes;
- location of power supply;
- accessibility for maintenance or repairs;
- solidity of the supporting surface;
- ventilation of the air-cooled condenser and necessary clearance;
- direction of prevalent winds: avoid positioning the unit in such a way that the prevalent winds favour the backflow of air to the condenser coils; a speed of 8 m/s (28.8 km/h) already generates a sufficient stagnation pressure to guarantee approx. 60% of the nominal air flow rate.[In situations where the action of air currents is inevitable and there is a simultaneous presence of temperatures below – 5°C, the control of condensation for low outdoor temperatures must be of the flooding type or with a device for choking the condensing exchanger -contact the technical department for further details]
- possible reverberation of sound waves.

All models belonging to the LCE series are designed and built for outdoor installation: avoid covering them with roof structures or positioning them near plants (even if they only partly cover the unit) which may interfere with the regular ventilation of the unit condenser.

It is a good idea to create a base of adequate dimensions to support the unit. This precaution becomes essential when the unit is to be sited on unstable ground (various types of soil, gardens, etc.).

It is advisable to place a rigid rubber strip between the base frame and the supporting surface.

Whenever more effective insulation is required, it is recommended to use vibrating-damping spring supports.

In the case of installation on roofs or intermediate storeys, the unit and pipes must be insulated from walls and ceilings by placing rigid rubber joints in between and using supports that are not rigidly anchored to the walls.

If the unit is to be installed in proximity to private offices, bedrooms or areas where noise levels must be kept down, it is advisable to conduct a thorough analysis of the sound field generated and verify its compatibility with the local laws in force.

## 5 INSTALLATION

### 5.1 INSTALLATION CLEARANCE REQUIREMENTS

It is of fundamental importance to ensure an adequate volume of air both on the intake and outlet sides of the finned condenser coils; it is highly important to prevent the air delivered from being re-aspirated as this may impair the performance of the unit or even cause an interruption in normal operation. For this reason it is necessary to guarantee the following clearances (see figure on this page):

- rear side/plumbing connections: min. 1.0 metre to guarantee access to plumbing connections and/or for any necessary maintenance on the pumps, reservoir, expansion tank and flow switch.
- electric control board side: min. 1.0 metre to guarantee access for inspection and/or maintenance of cooling components
- finned pack heat exchanger side: min. 1.5 metres to ensure proper air circulation and access to the compressor compartment, also from the side.
- top side: there must be no obstacle to expulsion.

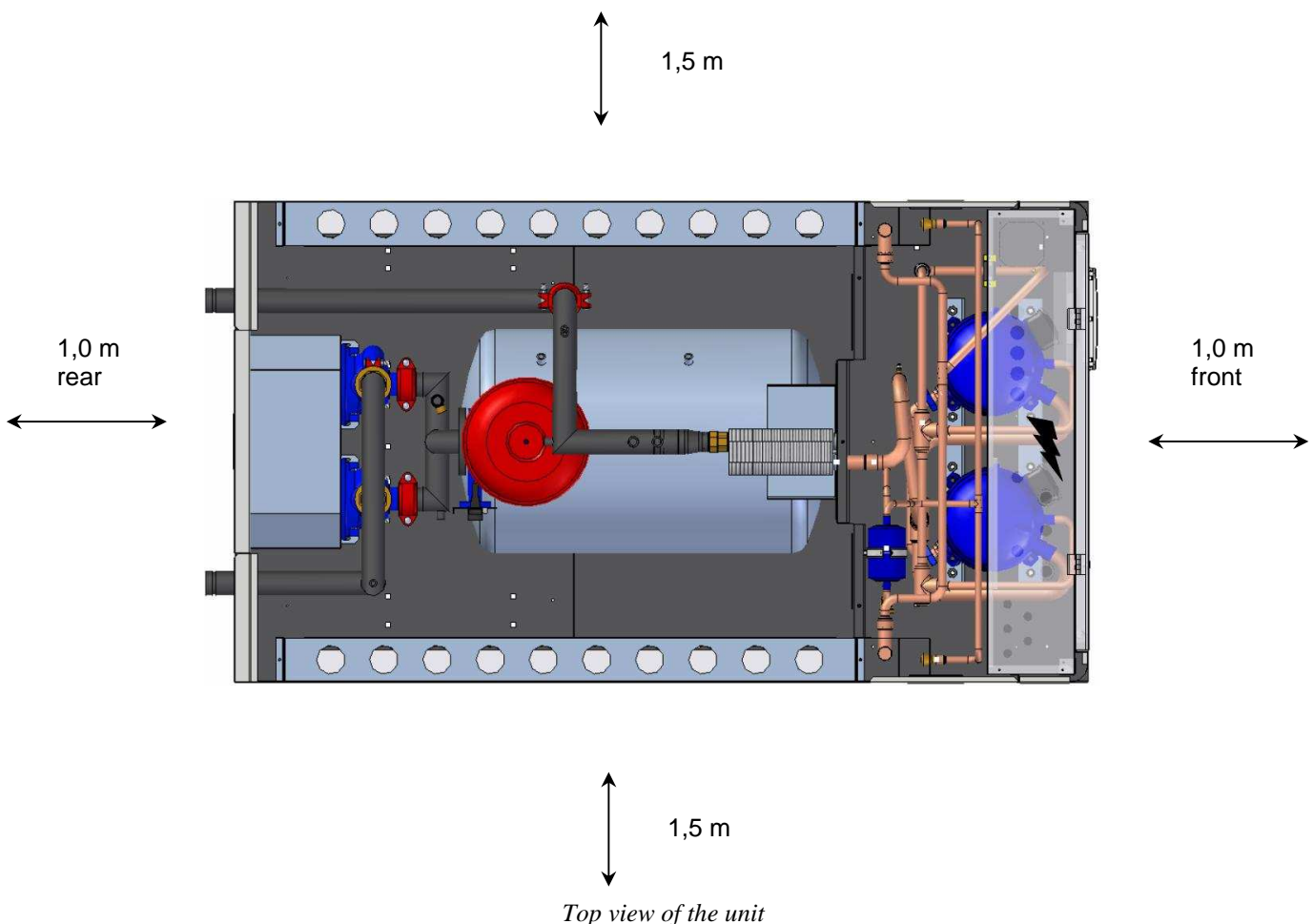

## 5.2 GENERAL GUIDELINES FOR PLUMBING CONNECTIONS

When you are getting ready to set up the water circuit for the evaporator you should follow the directions below and in any case make sure you comply with national or local regulations (use the diagrams included in this manual as your reference).

- Connect the pipes to the chiller using flexible couplings to prevent the transmission of vibrations and to compensate for thermal expansions. These units are all configured for installation of the water inlet-outlet pipes outside the unit (on the rear) and these pipes are supplied as a standard accessory at no extra cost for the customer.
- It is recommended to install the following components on the pipes:
  - pair of quick connect couplings with pipe section to be welded (optional that may be selected from the price list). They facilitate the operations of connecting to the plumbing system, greatly speeding up installation.

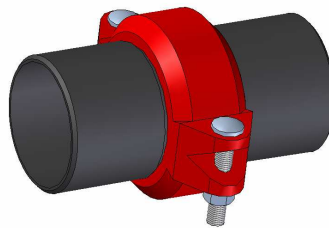

- temperature and pressure indicators for routine maintenance and monitoring of the unit. Checking the pressure on the water side will enable you to verify whether the expansion tank is working efficiently and to promptly detect any water leaks within the equipment.
- traps on incoming and outgoing pipes for temperature measurements, which can provide a direct reading of the operating temperatures. Temperature readings can in any case be obtained from the microprocessor installed on the unit.
- regulating valves (gate valves) for isolating the unit from the water circuit.
- metal mesh filter (incoming pipes), with a mesh not to exceed 1 mm, to protect the exchanger from scale or impurities present in the pipes.
- air vent valves, to be placed at the highest points of the water circuit for the purpose of bleeding air. [The internal pipes of the unit are fitted with small air vent valves for bleeding the unit itself: **this operation may only be carried out when the unit is disconnected from the power supply** - make sure that the circuit is completely full of water, then carefully bleed out the air and check again to make sure no air is present before starting the pump for the first time.
- drainage valve and, where necessary, a drainage tank for emptying out the equipment for maintenance purposes or when the unit is taken out of service at the end of the season. [A 1" drainage valve is provided on the optional water buffer tank: **this operation may only be carried out when the unit is disconnected from the power supply**].

### 5.3 WATER CONNECTION TO THE EVAPORATOR



It is of fundamental importance that the incoming water supply is hooked up to the connection marked "Water Inlet".

Otherwise the evaporator would be exposed to the risk of freezing since the antifreeze thermostat would not be able to perform its function; moreover the reverse cycle would not be activated in the cooling mode, resulting in additional risks of malfunctioning

The dimensions and position of plumbing connections are shown in the dimension tables at the end of the manual.



The water circuit must be set up in such a way as to guarantee that the nominal flow rate of the water supplied to the evaporator remains constant (+/- 15%) in all operating conditions.

The compressors often work intermittently, since the chilling requirements of the user generally do not coincide with the output of LCE unit. In systems containing little water, where the thermal inertia of the water is lower, it is a good idea to check that the water content in the section delivering to users satisfies the condition below:

$$V = \frac{Cc \times \Delta\tau}{\rho \times Sh \times \Delta T \times Ns}$$

V	= water content in user section	[m <sup>3</sup> ]
Sh	= specific heat of the fluid	[J/(kg/°C)]
ρ	= fluid density	[kg/m <sup>3</sup> ]
Δτ	= minimum time lapse between 2 compressor restarts	[s]
ΔT	= allowed water T differential	[°C]
Cc	= Cooling capacity	[W]
Ns	= N° of capacity control steps	

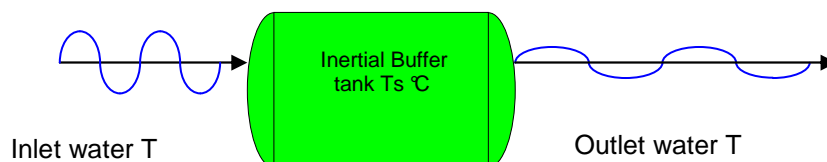



A **standard** feature of LCE units is a device for controlling the flow rate (differential pressure switch) in the water circuit in the immediate vicinity of the evaporator.

Any tampering with said device will immediately invalidate the warranty.

It is advisable to install a metal mesh filter on the inlet water pipe.



It is strongly recommended to install a safety valve in the water circuit. In the event of serious equipment faults (e.g. fire) it will enable water to be drained from the system, thereby preventing possible bursts. Always connect the drain outlet to a pipe with a diameter at least as large as that of the valve opening and direct it toward an area where the discharge of water cannot harm people. This is a standard feature of units equipped with the optional buffer tank (optional).



Warning: When making the plumbing connections, make sure there are no open flames in proximity to or inside the unit.

#### 5.4 PROCEDURE FOR FILLING THE STORAGE RESERVOIR



The storage reservoir is not designed to resist vacuum pressures greater than -0.15 bars. For this reason, attention should be paid to ensure that the pressure on the pump intake side, where the expansion tank is positioned, will always be greater than 0.5 bars **while the pump is running**: this also helps to reduce the risks of pump cavitation.

It is of fundamental importance for installers to follow and check the procedure described below, step by step, in order to prevent any risk of implosion of the storage reservoir or cavitation of the pump:

- a) Drain the expansion tank until the pressure falls to 0.5 bars
- b) Fill the system and pressurise it up to around + 1 bar on the pump intake side (pump off)
- c) Bleed air from the system
- d) Check the pump intake pressure (approx. 1 bar) and start up the system
- e) Stop the pump after 15-30 minutes and repeat the procedure from step **c)** until you can no longer hear any noises caused by the presence of air in the system.

## 5.5 SAFETY DEVICES ON THE HIGH PRESSURE SIDE



Cooling circuit safety devices are provided on each refrigerant circuit according to the volumetric capacity of the compressors installed, as prescribed by Directive 97/23 (PED); in particular, with respect to equipment design, this Directive requires manufacturers to abide by the technical standard nearest to the type of object produced; in the case of chillers designed for air conditioning or liquid cooling systems, standard UNI EN 378-2 is taken into consideration.

According to this standard, for refrigerant mass flow rates of up to 25dm<sup>3</sup> per circuit only one pressure limiting device is required; beyond this limit 2 must be applied. Practically speaking, these are safety pressure switches designed to protect the cooling circuit in a cascade fashion.

What is meant by cascade protection is illustrated in the figure:

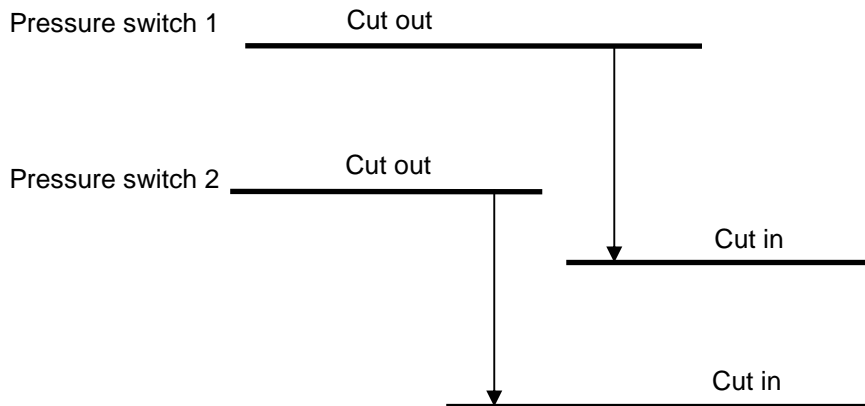

...where pressure switch 1 is set at the "PS" (maximum admissible pressure) of the system, while pressure switch 2 will have the setting = PS x 0.9 in accordance with the reference technical standard.

## 6 ELECTRICAL CONNECTIONS

### 6.1 GENERALITIES



Before carrying out any job on electrical parts, make sure the power supply is disconnected.

Check that the mains electricity supply is compatible with the specifications (voltage, number of phases, frequency) shown on the unit rating plate.

The power connection is made by means of a three-core cable plus neutral and earth cable or single-core cables (one per phase) + earth according to the minimum cross section sizes specified in the wiring diagram, which is an integral part of the documentation accompanying the chiller; the diagram code also appears on the rating plate inside the compressor compartment.



The size of the cable and line protections must conform to the specifications provided in the wiring diagram.

The supply voltage may not undergo fluctuations exceeding  $\pm 5\%$  and the unbalance between phases must always be below 2%.



The above operating conditions must always be complied with: failure to ensure said conditions will result in the immediate invalidation of the warranty.

The electrical connections must be made in accordance with the information shown in the wiring diagram provided with the unit and current regulations.

*Electrical connections and preliminary checks::*

- *Put on the main switch, turn the ½-turn locking screws of the electric enclosure and open it.*
- *Introduce the power cable 400/3/50+N through the hole provided on the left side of the unit (after first removing and making a hole in the aluminium square based on the diameter of the electric cable) and secure it with a cable gland.*
- *Connect the power supply and earthing wire to the terminals of the main switch.*
- *Open the fuse carriers F1 and F2 (or Q1 and Q2 for the motor overload cutouts) of the compressors (F1-F2-F3-F4 for the fuses or Q1-Q2-Q3-Q4 for the overload cutouts in the case of LCE 4 compressor models) to prevent them from starting up in the wrong direction in the event of an incorrect phase sequence.*
- *Switch on the power supply by turning the main switch (QS) to ON.*
- *Verify whether the phase sequence R-S-T is correct by checking, on the phase sequence relay situated in the middle of the electric control board, that the green power on LED and yellow LED indicating the correct sequence both light up; if this does not occur, disconnect the chiller power supply from the external distribution panel and swap over two phases; then repeat the operation. IN NO CASE SHOULD YOU TAMPER WITH THE WIRING DOWNSTREAM FROM THE MAIN SWITCH since this may alter the correct sequence of other devices, e.g. pump(s).*
- *Close the fuse carriers F1 and F2 of the compressors (F1-F2-F3-F4 in the case of LCE 4 compressor models).*
- *Close the electric enclosure and lock it by means of the ½ turn locks.*

An earth connection is required by law. The installer must connect the earthing wire using the earthing terminal situated on the electric control board (yellow and green wire).

The power supply to the control circuit is shunted from the power line through an insulating transformer situated on the electric control board.

The control circuit is protected by suitable fuses.

A **standard** feature of all units is a phase sequence relay that verifies the correct phase sequence; this is necessary to assure that the chiller is completely functional before enabling a compressor start-up

## 6.2 ELECTRICAL CONNECTIONS DIFFERENTIAL WATER PRESSURE SWITCH

A differential pressure switch is present and wired on all units belonging to the LCE series. Available as an optional feature for all units is an additional blade-type flow switch installed in series with the water and electrical circuits and wired, if chosen, in the unit configuration.

## 6.3 ELECTRIC CONNECTIONS OF THE CIRCULATION PUMP

If selected on ordering, it/they is/are supplied pre-wired with all LCE units. For dual pump kits, whether set up according to an "AND" or "OR" logic, rotation is controlled on a time basis and triggered in the event of a fault.



The pump must be started before the chiller and stopped after the latter (minimum recommended delay: 60 seconds). If included as an option, this function is already performed by the microprocessor on the unit.



### 6.4 REMOTE CONTROLS

If you wish to include a remote control for switching the unit on and off, you must remove the jumper between the contacts indicated in the wiring diagram and connect the remote ON/OFF control to the terminals themselves [see annexed wiring diagram].



All remote controls work with a very low voltage (24 Vac) supplied by the insulating transformer on the electric control board.

### 6.5 REMOTE SUMMER-WINTER SWITCHING

If you wish to include a remote control for switching the unit between the summer and winter operating modes, you must remove the jumper between the contacts indicated in the wiring diagram and connect the remote switching control to the terminals themselves [see annexed wiring diagram]. The switching modes vary according to whether the microprocessor control is of the basic or advanced type: : detailed instructions are provided below (see extract of corresponding wiring diagram) and in the microprocessor user manual, an integral part of the documentation provided.

## mChiller

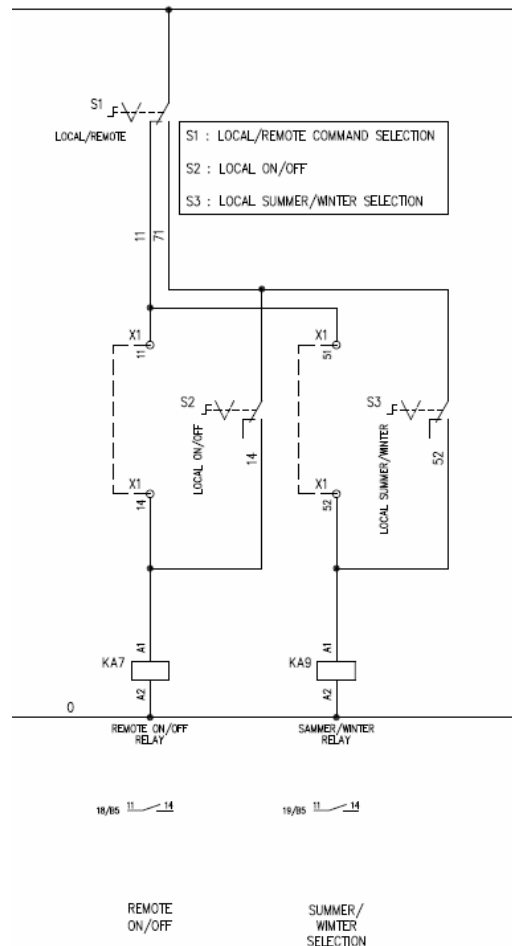
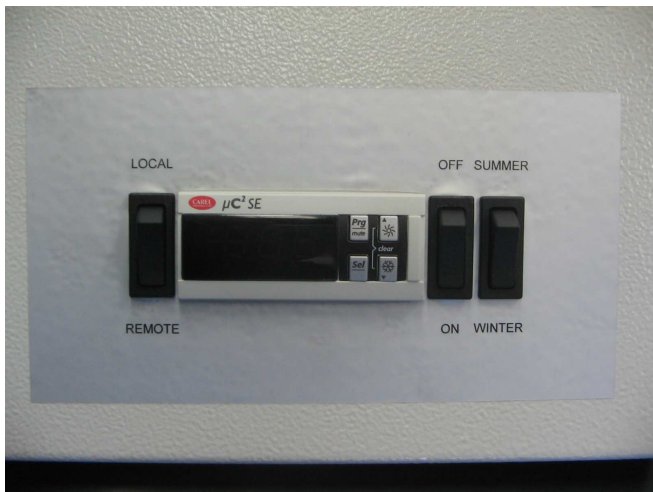

## pCo

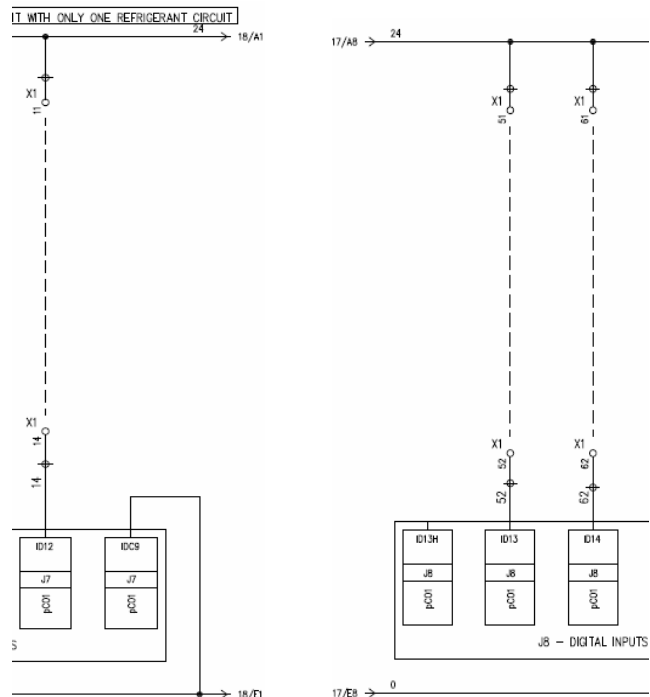
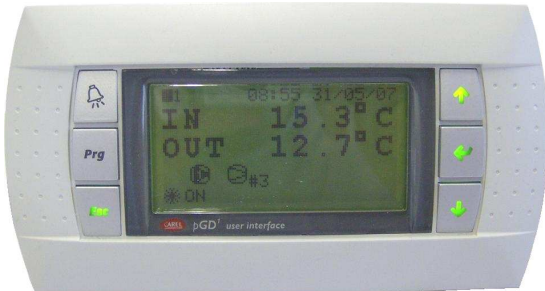

REMOTE  
ON/OFF

SUMMER/  
WINTER  
SELECTION

REMOTE  
SETPPOINT/  
SERIOUS  
EXTERNAL  
ALARM

## 7 STARTING UP

### 7.1 PRELIMINARY CHECKS

- Check that all the valves in the cooling circuit are open (liquid line).
- Check that the electrical connections have been made properly and that all the terminals **are securely tightened**. This check should also be included in a periodic six-month inspection.
- Check that the voltage at the RST terminals is 400 V  $\pm$  5% and **make sure** the yellow indicator light of the phase sequence relay is on. The phase sequence relay is positioned in the middle right part of the electric control board; if the sequence is not duly observed, it will not enable the machine to start.
- Make sure there are no refrigerant leaks that may have been caused by accidental impacts during transport and/or installation.
- Check the power supply to the crankcase heating elements, where present.



The heating elements must be turned on at least 5-10 minutes before the unit is started. This function is carried out automatically when the main switch is off. Their function is to raise the T of the oil in the sump and limit the quantity of refrigerant dissolved in it.

To verify whether the heating elements are working properly, check the lower part of the compressors: it should be warm or in any case at a temperature 10 -15°C higher than the ambient temperature.

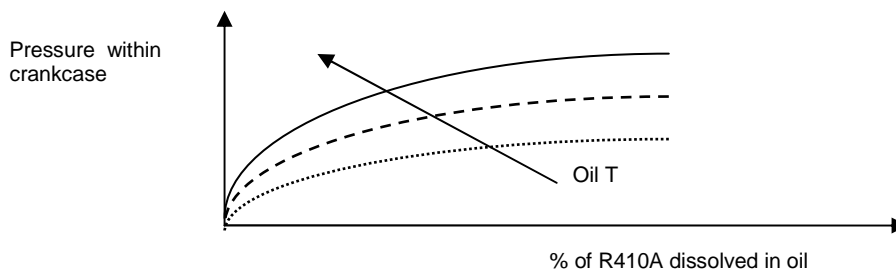

The diagram above illustrates a specific property [Charles' Law] of gases, which are more soluble in liquids as the pressure increases but less soluble as the temperature increases: if the oil is held at a constant pressure, an increase in temperature will significantly reduce the amount of refrigerant dissolved in it, thus ensuring that the lubricating function desired is maintained. At the same time it should be observed that a slight foaming [ 1-5 mm] of the oil at start up ( pressure drop => decrease in % of solubility ) is normal and will not compromise the system's reliability.

- Check that the plumbing connections have been properly made according to the indications given on the plates to be found on the unit itself (proper inlet and outlet connections).
- Make sure that the water circuit is duly bled to completely eliminate the presence of air: fill the circuit gradually and open the air vent valves on the top part, which the installer should have set in place.

## 7.2 STARTING OPERATION

Before starting the chiller, turn the main switch off, select the operating mode desired from the control panel [red button = heating, green button = cooling] and press the "ON" button on the control panel.

The unit will start up if enabled:

- by the safety devices of the water circulation pump/s
- by the flow switch (or differential pressure switch)
- by the T sensor measuring the temperature of the water returning from the system [chiller inlet]
- and no alarms have been triggered.

### Starting up

- Check that all external cocks of the water circuit are open and water flows properly (the flow alarm should not be triggered)
- Put the main switch in the ON position.
  - The pump will start immediately.
  - After 60 seconds the compressor will start
- Check the water temperature differential (12-7°C to be detected by means of a thermometer on the inlet and outlet water pipes of the unit).
- Check that there are no leaks on the refrigerant side and water side.
- Using all the screws supplied, close the unit.

If the unit fails to start up, check whether the set point has been set on the desired values.



You should not disconnect the unit from the power supply during periods when it is inoperative but only when it is to be taken out of service for a prolonged period (e.g. at the end of the season). To turn off the unit temporarily follow the directions provided in the section "Stopping the Unit".

### 7.3 CHECKS DURING OPERATION

- Check the phase sequence relay on the control board to verify whether the phases occur in the correct sequence: if they do not, disconnect the unit from power supply and reverse two phases at the unit input. **Never** attempt to modify internal electrical connections: any undue modifications will render the warranty null and void.



All the three-phase devices on the unit, compressor, water pump and fans (some versions) have a set direction of rotation and were harmonized in the factory.

- Check that the temperature of the water entering the evaporator (returning from the system) is close to the setpoint value entered. How long it will take to reach full operating capacity depends on the starting conditions, system size and load conditions.

### 7.4 CHECKING THE REFRIGERANT LEVEL

- After a few hours of operation, check whether the liquid level indicator has a green crown: a yellow colour indicates the presence of humidity in the circuit. In such a case the circuit must be dehumidified by qualified personnel.
- Large quantities of bubbles should not appear through the liquid level indicator. A constant passage of numerous bubbles may indicate that the refrigerant level is low and needs to be topped up.
- A few minutes after the compressors have started up, check that the end-of-condensation temperature shown on the pressure gauge (refer to the pressure gauge scale for the refrigerant R410A, marked with the initials D.P. - Dew Point) is about 16-22 °C (depending on the type of unit and charging conditions) higher than the temperature of the air entering the condenser with the fans running at top speed.
- Also check that the end-of-evaporation temperature shown on the pressure gauge (refer to the pressure gauge scale for the refrigerant R410A, marked with the initials D.P. - Dew Point) is about 3.5 - 5.0 °C lower than the temperature of the water leaving the evaporator.
- Make sure the superheating of the refrigerant fluid is limited to between 5 and 8 °C. To this end:
  - 1) read the temperature indicated by a contact thermometer placed on the compressor intake pipe;
  - 2) read the temperature indicated on the scale of a pressure gauge likewise connected to the intake side; refer to the pressure gauge scale for the refrigerant R410A, marked with the initials D.P. (Dew Point).The degree of superheating is given by the difference between the temperatures thus determined.
- Make sure that the subcooling of the refrigerant fluid is limited to between 4 and 6°C. To this end:
  - 1) read the temperature indicated by a contact thermometer placed on the condenser outlet pipe;
  - 2) read the temperature indicated on the scale of a pressure gauge connected to the liquid inlet at the condenser outlet; refer to the pressure gauge scale for the refrigerant R410A, marked with the initials B.P. (Bubble Point).

The degree of subcooling is given by the difference between the temperatures thus determined.



Warning: all LCE units are charged with HFC R410A: any top-ups must be made by specialised personnel using the same type of refrigerant, exclusively in the liquid phase.



Warning: the refrigerant R410A requires "POE" polyolester oil of a type approved by the compressor manufacturer.  
For no reason should a mineral oil be introduced into the oil circuit.

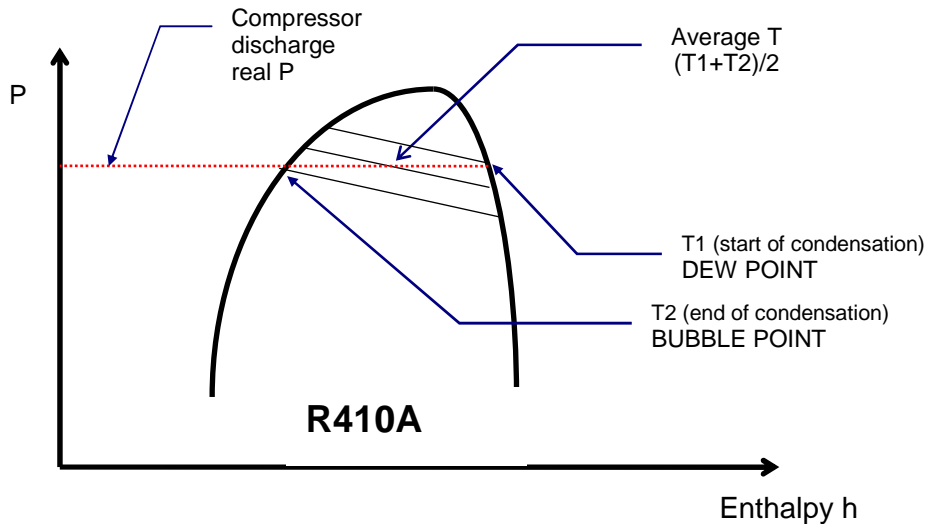

- The difference between the Dew Point and Bubble Point is known as "GLIDE" and this is a characteristic property of refrigerant mixtures. If pure fluids are used, the phase change occurs at a constant T and thus the glide is equal to zero. If HFC R410A [ 50%-50% blend of R32 and R125] is used, the glide will be negligible (0.2°C) and the fluid can be considered like a pure fluid.

## 7.5 EXPANSION VALVE

An electronically controlled expansion valve is installed as a standard feature on all LCE units. . If correctly parameterised and controlled by the software, this device has the ability to render the operation of the cooling circuit highly efficient and this will have the ultimate effect of decreasing the power intake of the system when a sudden change occurs in the thermal load, with a traditional expansion valve there is a transient time of 2 to 3 minutes before a condition of equilibrium is reached

Example:

- A compressor switches off
- The evaporation temperature increases
- Superheating decreases
- The valve closes
- The refrigerant flow rate decreases
- The cooling capacity decreases
- The evaporation temperature decreases

...and so on



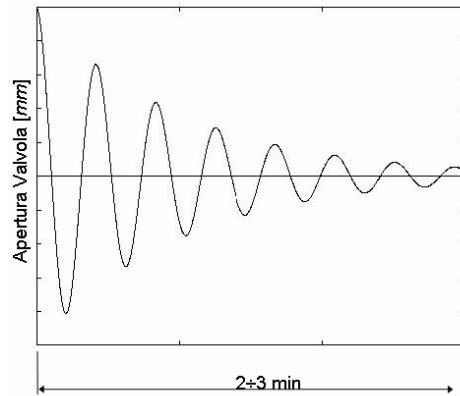

### Proactive action of an Electronic Expansion Valve:

In the event of a compressor on/off request:

- ✓ The electronic driver pre-positions the valve at a point very near the final equilibrium point
- ✓ A status of equilibrium is quickly reached with small adjustments
- ✓ The electronic expansion valve becomes an active, rather than passive, component within the system
- ✓ The transient time is greatly reduced
- ✓ Overall the system is more efficient, with higher EERs and therefore greater savings

## 7.6 STOPPING THE UNIT

The unit can be stopped by pressing the "OFF" button on the front panel, by turning off the main switch, or via the specific commands on the LCD user interface..



Warning: you should avoid stopping the unit using the main switch. The latter device should be used to disconnect the unit from the electricity supply when there is no passage of current, i.e. when the unit is already turned OFF. Moreover, if you completely disconnect the unit from the electricity supply, the crankcase heating elements will receive no power, thereby jeopardising the integrity of the compressor the next time the unit is started.

## 8 OPERATING LIMITS

Operating limits of LCE chillers in relation to the outlet water temperature (in brackets, in cooling mode) and outdoor air temperature:

	Min.	Max.
Evaporator outlet water temperature [°C]:	5 (30)	12 (45)
External air temperature [°C]:	-10	45

### 8.1 WATER FLOW TO EVAPORATOR

The nominal flow rate is based on a temperature differential of 5° C between inlet and outlet water, in relation to the cooling capacity provided at the nominal water (12/7 °C) and air (35°C) temperatures.

The maximum allowed flow rate is associated with a temperature differential of 3 °C. Higher flow rates, though admissible, cause pointless, high drops in pressure.

The minimum allowed flow rate is associated with a temperature differential of 8 °C or a minimum pressure drop of 10 kPa: lower flow rates cause a reduction in heat exchange coefficients and excessively low evaporation temperatures, which may trigger the safety devices and cause the unit to stop.

## 8.2 CHILLED WATER TEMPERATURE

The minimum temperature of the water leaving the evaporator is 5°C: lower temperatures are possible, but for such applications the Manufacturer should be consulted at the time the order is placed.

The maximum temperature of the water entering the evaporator is 20°C. To allow higher temperatures specific equipment solutions must be adapted (split circuits, three-way valves, bypasses, storage reservoirs): applications outside the specified limits may be authorised by Lennox S.p.A. subject to verification and subsequent authorisation in writing.

## 8.3 OUTDOOR AIR TEMPERATURE

The units are designed and built to work with outdoor air temperatures ranging from -10 (with condensation control) to 45 °C : applications outside the specified limits may be authorised by Lennox S.p.A. subject to verification and subsequent authorisation in writing. On request, the units may be equipped with an electric heating element for heating the evaporator in cases where the unit is exposed to severe temperatures during wintertime shutdown periods. The heating element is activated whenever the temperature of the water leaving the evaporator falls below the temperature set on the antifreeze probe.

## 8.4 OPERATION WITH WATER AT LOW TEMPERATURES



The standard units are not designed to work with chilled water temperatures below 5°C at the evaporator outlet. In order to work below this limit, the unit requires specific technical adjustments: in such cases contact the Manufacturer.

# 9 SETTING OPERATING PARAMETERS

## 9.1 GENERALITIES

All the control devices are set and tested in the factory before the unit is dispatched. However, after the unit has been in service for a reasonable period of time you can perform a check on the operating and safety devices. The settings are shown in Tables I and II.



**The control devices may be serviced SOLELY BY QUALIFIED TECHNICIANS: incorrect settings may cause serious damage to the unit and injury to persons.**

Many of the operating parameters and system settings are configured by means of the microprocessor control and are protected by passwords.

**TABLE I – SETTING OF CONTROLDEVICES**

- LCE SERIES

CONTROL DEVICE		SET POINT	DIFFERENTIAL
Service thermostat [CS-CL-CQ]	°C	12	4
Service thermostat [HS-HL-HQ]	°C	40	4



TABLE II – SETTING OF SAFETY - CONTROL DEVICES

- LCE SERIES

CONTROL DEVICE		ACTIVATION	DIFFERENTIAL	RESETTING
Antifreeze thermostat	°C	+4	1	Automatic
Safety maximum pressure switch	bars	45	-13,5	Manual
Safety maximum pressure switch	bars	40,5	-12,2	Manual
High pressure relief valve	bars	-	-	-
Minimum pressure switch	bars	1,5	+1,0	Automatic
Modulating condensation control device	bars	18	10	
Time lapse between two starts of the same compressor	s	450	-	-
Delay in flow switch alarm	s	20	-	-
Delay in low pressure alarm	s	1	-	-
Pump rotation [optional]	h	6	-	-
End-of-defrost pressure	bars	29	-	-
Maximum defrost time	s	360	-	-
Minimum time lapse between two defrosting operations	s	1800	-	-

NB: some units may be fitted (for internal requirements) with a safety valve set at 44 bars in combination with a high pressure switch set at 42 bars.

## 9.2 MAXIMUM PRESSURE SWITCH

The high pressure switch is of the manually reset type and classifiable as category IV under EEC 97/23. It directly stops the compressor when the discharge pressure exceeds the set value (see section 5.4).

To verify its efficiency, while the compressors are running, close off the passage of air into the condensers and check by referring to the compressor outlet pressure gauge (previously installed) whether the pressure switch trips (i.e. the compressors stop) when the set value is reached.



Warning: during this operation, if the safety device fails to trip, the second cascade-connected pressure switch will step in to shut down the unit; in any event, however, you should be ready to shut off the unit as directed in the section "Stopping the Unit" – see also section 5.4.

The high pressure switch must be **manually reset**; this is possible only when the pressure falls below the set differential (see Table II).

## 9.3 MINIMUM PRESSURE SWITCH

The low pressure switch stops the compressor when the intake pressure falls below the set value for more than 60 seconds.

The switch is automatically reset when the pressure rises above the set differential (see Table II); however, the unit will not resume operation until the alarm memory on the microprocessor control is cleared.

## 9.4 SERVICE THERMOSTAT

The function of this device is to start and stop the compressors according to the demand for chilled water, as determined by a sensor placed at the evaporator inlet [water returning from the circuit]. This device is a function included in the microprocessor control and works with a proportional bandwidth that may be set as desired.



## 9.5 ANTIFREEZE THERMOSTAT

The antifreeze sensor situated at the evaporator outlet detects the presence of excessively low temperatures and stops the unit. Together with the flow switch and low pressure switch, this device protects the evaporator from the risk of freezing as a result of faults in the water circuit. This device is a function included in the microprocessor control.

## 9.6 ANTI-RECYCLE TIMER

The function of the timer is to prevent excessively frequent compressor starts and stops. This device is a function included in the microprocessor control. It imposes a minimum time lapse of 300 seconds between two successive starts.



Never attempt to change the delay set in the factory: wrong settings could cause serious damage to the unit.

## 9.7 OIL DIFFERENTIAL PRESSURE SWITCH

LCE units are equipped with spinning scroll compressors; these compressors do not have a lubricant pump and therefore no oil differential pressure switch is provided.

# 10 ROUTINE MAINTENANCE AND CHECKS

## 10.1 WARNINGS



All the operations described in this chapter **MUST ALWAYS BE PERFORMED BY QUALIFIED PERSONNEL.**



Before carrying out any work on the unit or accessing internal parts, make sure you have disconnected it from the mains electricity supply.



The upper part and outlet pipe of the compressor may reach temperatures as high as 110°C. Be especially careful when working in the surrounding area while the unit is running.



Be especially careful when working in proximity to finned coils since the 0.11 mm-thick aluminium fins can cause superficial injuries due to cuts.



After completing maintenance jobs, always replace the panels enclosing the units and secure them with the fastening screws provided.

## 10.2 GENERALITIES

It is a good idea to carry out periodic checks to ensure that the unit is working properly:

- Check the efficiency of all the control and safety devices as previously described.
- Check the terminals on the electric control board and compressor terminal boards to ensure that they are securely tightened. The movable and fixed contacts of the circuit breakers must be periodically cleaned and replaced whenever they show signs of deterioration.
- Check the refrigerant level by means of the liquid level indicator (every 6 months).
- Check the oil levels through the windows provided on the compressor crankcases (every 6 months).
- Check the water circuit for leaks (every 6 months).
- Check the filling of the water circuit, bleeding air from the circuit by means of the valves situated in the highest points.
- Check the efficiency of the flow switch or differential pressure switch
- Check the heating elements, where present, of the compressor crankcases.
- Clean the metal mesh filters mounted externally on the water pipes.
- Check the humidity indicator on the liquid level indicator (green=dry, yellow=humid); if the indicator is not green as shown on the indicator sticker, replace the filter (every 6 months).
- Check that the noise emissions of the unit are regular (every 6 months) and more specifically that no vibrations and/or knocking can be detected.

## 10.3 REPAIRING THE COOLING CIRCUIT



**Warning: while performing repairs on the cooling circuit or maintenance work on the compressors, make sure the circuit is left open for as little time as possible. Even if briefly exposed to air, ester oils tend to absorb large amounts of humidity, which results in the formation of weak acids.**

If the cooling circuit has undergone any repairs, the following operations must be carried out:

- tightness test;
- emptying and drying of the cooling circuit;
- charging with refrigerant.



**If the system has to be drained, always recover the refrigerant present in the circuit using suitable equipment; the refrigerant should be handled exclusively in the liquid phase.**

## 10.4 TIGHTNESS TEST

Fill the circuit with anhydrous nitrogen supplied from a tank with a pressure-reducing valve until the pressure rises to 10 bars.



**During the pressurisation phase, do not exceed the pressure setting of the safety valves; otherwise you will cause the latter to open.**

The presence of any leaks must be determined using special leak detectors. Should any leaks be detected during the test, empty out the circuit before repairing the leaks with suitable alloys.



Do not use oxygen in the place of nitrogen as a test agent, since this could cause a risk of explosion as well as the certainty of extensive oxidisation in high-temperature areas.

### 10.5 HARD VACUUM AND DRYING OF THE COOLING CIRCUIT

To achieve a hard vacuum in the cooling circuit it is necessary to use a pump capable of generating a high degree of vacuum, i.e. 15 Pa of absolute pressure.

If there is no suitable vacuum pump available, or whenever the circuit has remained open for long periods of time, you are strongly recommended to adopt the triple evacuation method. This method is also recommended when there is a presence of humidity within the circuit.

The vacuum pump should be connected to the inlets.

The procedure to be carried out is as follows:

- Evacuate the circuit until you reach an absolute pressure of at least 35 Pa. At this point inject nitrogen into the circuit until you reach a relative pressure of about 1 bar.
- Repeat the step described above.
- Carry out the step described above for the third time, but in this case attempting to reach the hardest vacuum possible.

Using this procedure you can easily remove up to 99% of pollutants.

### 10.6 CHARGING WITH R410A REFRIGERANT

- Connect the tank of refrigerant gas to the male 1/4 SAE inlet situated on the liquid line after discharging a little gas to eliminate air in the connection pipe.
- **Carry out the charging operation with the refrigerant in liquid form** until you reach 75% of the total charge.
- Then connect to the inlet on the intake line and complete the charging process with the refrigerant **in liquid form** until no more bubbles can be seen on the liquid level indicator and the operating parameters specified in the section "Checking the refrigerant level" have been reached.



Since R410A is a binary blend of R32 and R125, it is advisable to charge with refrigerant in the liquid phase to ensure the correct percentage of the 2 components. Charge through the charging inlet provided between the expansion valve and evaporator inlet.



A unit that was originally charged with R410A in the factory cannot be charged with other refrigerants.

## 10.7 ENVIRONMENTAL PROTECTION

The law implementing the regulations [reg. EEC 2037/00] which govern the use of ozone-depleting substances and greenhouse gases bans the dispersal of refrigerant gases in the environment and requires whoever is in their possession to recover them and, at the end of their useful life, either to return them to the dealer or take them to a suitable waste disposal facility.

The refrigerant HFC R410A is not harmful to the ozone layer but is included among the substances responsible for the greenhouse effect and thus falls within the scope of the aforesaid regulations.



Therefore, special care should be taken when carrying out maintenance work to minimise refrigerant leaks.

## 11 RETIRING THE UNIT

When the unit has reached the end of its working life and needs to be removed and replaced, a series of operations should be carried out:

- the refrigerant gas it contains should be recovered by specialised personnel and sent to a waste collection facility;
- the lubricating oil in the compressors should also be recovered and sent to a waste collection facility;
- if they cannot be reused, the framework and components should be scrapped and separated according to the type of material: this applies especially for the considerable quantities of copper and aluminium present in the unit.

This will make the job of waste collection, disposal and recycling facilities easier and minimise the environmental impact of such processes.

## 12 TROUBLESHOOTING

On the next pages you will find a list of the most common causes that may cause the chilling unit to fail or malfunction. These causes are broken down according to easily identifiable symptoms.



You should be extremely careful when attempting to implement any of the possible remedies suggested: overconfidence can result in injuries, even serious ones, to inexperienced individuals. Therefore, once the cause has been identified, you are advised to contact the manufacturer or a qualified technician for help.

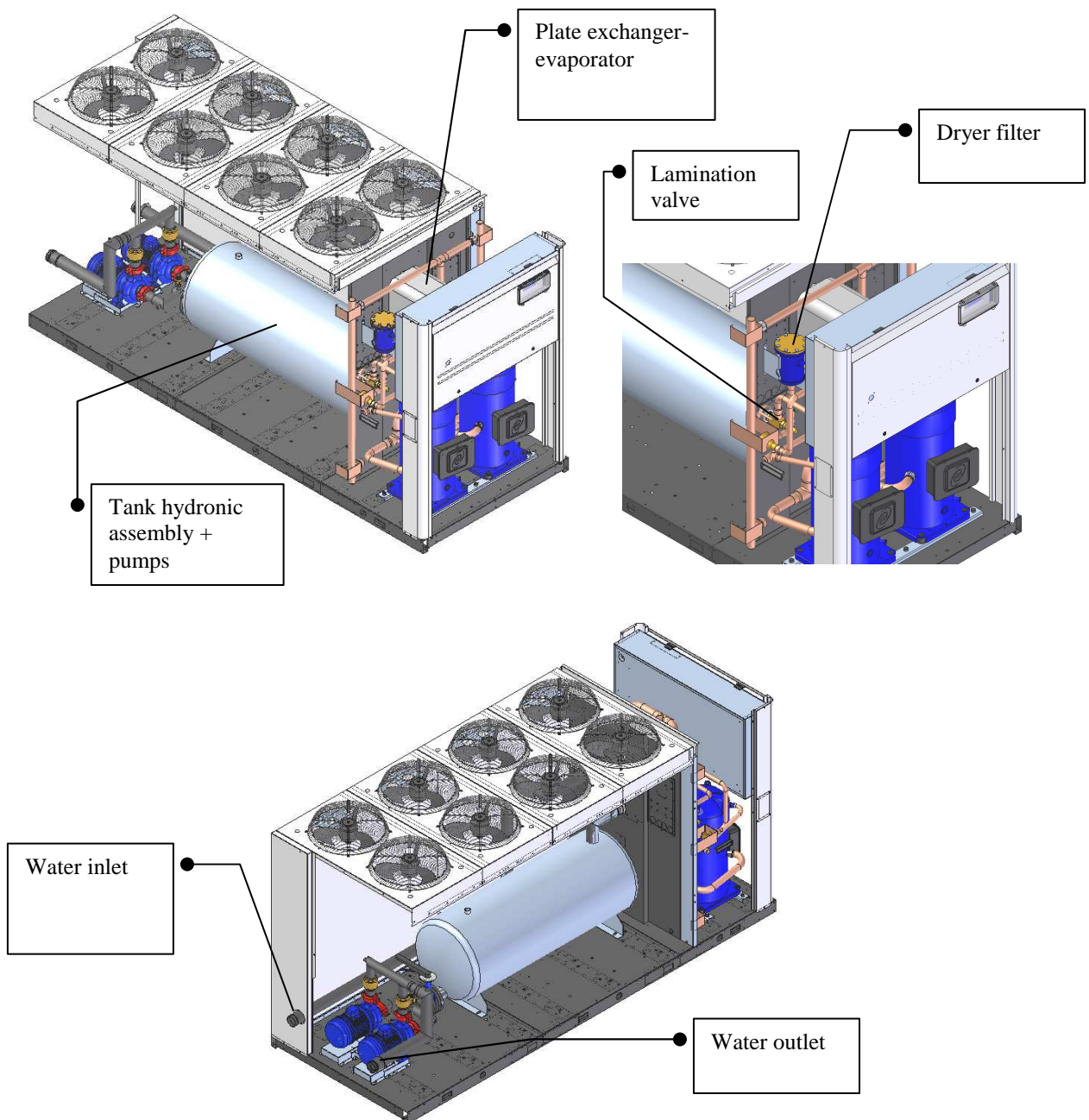

FAULT	Possible causes	Corrective actions
<b>The unit does not start.</b>	No power supply.	Check that power is being supplied both to the primary and auxiliary circuits.
	The electronic card is cut off from the power supply.	Check the protections.
	Alarms have been triggered.	Check whether any alarms are signalled on the microprocessor control panel, eliminate the causes and restart the unit.
	The phase sequence is wrong.	Reverse two phases in the primary power line after disconnecting them upstream from the unit.
<b>The compressor is noisy.</b>	The compressor is rotating in the wrong direction.	Check the phase sequence relay. Reverse the phases on the terminal board after disconnecting the unit and contact the manufacturer.
<b>Presence of abnormally high pressure.</b>	Insufficient flow of air to the condenser.	Check whether all the fans are turning properly.
		Check the air T at the condenser inlet and make sure no back suction occurs.
		Check whether the effective RMS voltage to the fans is the maximum. If necessary, check the pressure transducers via the revolution speed controller, where present [optional].
		Check the cleanliness of the finned coils.
	Presence of air in the refrigerant circuit, as revealed by the presence of bubbles in the flow indicator also with subcooling values exceeding 5 °C.	Drain and pressurise the circuit and check for leaks. Generate a slow vacuum [longer than 3 hours] until reaching a pressure of 15 Pa and then recharge in the liquid phase.
	Unit overcharged, as revealed by a subcooling of more than 8 °C.	Drain the circuit.
	Thermostatic valve and/or filter obstructed. These symptoms may also occur in the presence of an abnormally low pressure.	Check the temperatures upstream and downstream from the valve and filter and replace them if necessary.
Insufficient flow of water in the case of heat pump operation.	Check the water circuit for pressure drops and/or whether the pump is working properly [direction of rotation]. Check the outgoing water T and make sure it is less than or equal to 45°C.	

FAULT	Possible causes	Corrective actions
<b>Low condensation pressure.</b>	Transducer fault.	Check the transducers and the efficiency of the needle pusher on the schrader valves they are connected to.
	Outdoor T too low and/or presence of strong winds.	Install the condensation control device and/or protect the unit from prevalent winds.
	Low water T, in the case of heat pump operation.	Check whether the thermal load is compatible with the unit's potential.
<b>Low evaporation pressure.</b>	Insufficient flow of water.	Check whether the pumps are rotating in the right direction. Check the water system for pressure drops. Check the efficiency of the pump system check valve (optional).
	Malfunctioning of thermostatic valve.	Warming the bulb with your hand, check whether the valve opens and adjust it if necessary. If it does not respond, replace it.
	Filter clogged.	Pressure drops upstream and downstream from the filter should not exceed 2°C. If they do, replace the filter.
	Low condensation T.	Check the efficiency of the condensation control device [where present].
	Low level of refrigerant.	Check the refrigerant level by measuring the degree of subcooling; if it is below 2°C replenish the charge.
	Coil covered with frost, in the case of heat pump operation.	Check whether the defrost parameters have been properly set. Check the efficiency of the 4-way valve.
	Low outdoor T, if the unit is operating with the heat pump on.	Check compliance with the operating limits and eliminate any bypasses and back flow of air.
<b>The compressor does not start.</b>	The internal thermal protection device has tripped.	In the case of compressors equipped with a protection module, check the thermal contact. Identify the causes after restarting.
	The circuit breakers or line fuses have been tripped by a short circuit.	Pinpoint the cause by measuring the resistance of the individual windings and the insulation to the casing before restoring power.
	One of the high or low pressure switches has tripped.	Check on the microprocessor, eliminate the causes.
	The phases have been reversed in the distribution compartment.	Check the phase sequence relay.



FAULT	Possible causes	Corrective actions
<b>High evaporation pressure.</b>	Water T too high.	Check the thermal load and/or efficiency of the thermostat function. Check the efficiency of the thermostatic valve.
<b>Defrosting absent or incomplete (HS-HL-HQ versions).</b>	Error in parameter settings.	Check the setting of the start and end defrost parameters on the microprocessor. Check whether defrosting water is properly drained from the coils. Check the uniformity of the refrigerant circuit outlet temperatures at the top and bottom of the coils: the maximum temperature differential allowed is 10 °C. Check the refrigerant level.
	The 4-way valve has failed to work.	Check whether it is regularly energized and deenergized.

## 13 WATER PRESSURE DROPS

### 13.1 PRESSURE DROPS IN EVAPORATOR

NB: for further details contact the Lennox technical department.

### 13.2 PRESSURE DROPS IN HEAT RECUPERATOR

NB: for further details contact the Lennox technical department.



## 14 SUMMARY TECHNICAL DATA

The technical data table is divided according to **efficiency pack** (ref. Table par. 1).

Approximate unit **size** in terms of cooling capacity = 100kW in this case

**Range**

**LCE 104HQ**

**Configuration**

C = cooling only

H = heat pump

F = free-cooling

**Version**

Standard = S

Silenced = L

Supersilenced = Q

**Efficiency Pack 4** = 2 tandem compressors on 2 circuits

**Efficiency Pack 2** = 2 tandem compressors on 1 circuit

**Efficiency Pack 1** = 1 compressor per circuit

LCE		42 <sup>(3)</sup>	52 <sup>(3)</sup>	62	72	82	9 <sub>-</sub>	10 <sub>-</sub>	12 <sub>-</sub>	14 <sub>-</sub>
Cooling capacity <sup>1</sup>	kW	47,9	52,9	63,3	69,2	76,5	92,2	102,7	124,1	138,4
Total Input power <sup>1</sup>	kW	16,2	18,2	21,4	24,2	27,8	31,3	37,7	40,8	45,9
Heating capacity <sup>2</sup>	kW	55,3	61,0	70,5	78,1	86,0	103,2	116,3	136,0	155,7
Electrical input-heating mode <sup>2</sup>	kW	15,8	17,8	21,0	23,46	26,8	29,5	34,2	38,3	43,6
EER efficiency pack 1		<i>n.d.</i>	<i>n.d.</i>	<i>n.d.</i>	<i>n.d.</i>	<i>n.d.</i>	2,94	2,72	3,04	3,01
EER efficiency pack 2		2,95	2,91	2,96	2,86	2,75	2,94	2,72	3,04	3,01
EER efficiency pack 4		<i>n.d.</i>	<i>n.d.</i>	<i>n.d.</i>	<i>n.d.</i>	<i>n.d.</i>	<i>n.d.</i>	<i>n.d.</i>	3,01	3,00
ESEER efficiency pack 1		<i>n.d.</i>	<i>n.d.</i>	<i>n.d.</i>	<i>n.d.</i>	<i>n.d.</i>	3,45	3,40	3,88	3,93
ESEER efficiency pack 2		4,06	4,04	4,05	4,01	3,98	4,00	3,95	4,22	4,18
ESEER efficiency pack 4		<i>n.d.</i>	<i>n.d.</i>	<i>n.d.</i>	<i>n.d.</i>	<i>n.d.</i>	<i>n.d.</i>	<i>n.d.</i>	4,09	4,10
COP efficiency pack 1		<i>n.d.</i>	<i>n.d.</i>	<i>n.d.</i>	<i>n.d.</i>	<i>n.d.</i>	3,31	3,23	3,34	3,39
COP efficiency pack 2		3,50	3,43	3,35	3,33	3,21	3,32	3,23	3,35	3,39
COP efficiency pack 4		<i>n.d.</i>	<i>n.d.</i>	<i>n.d.</i>	<i>n.d.</i>	<i>n.d.</i>	<i>n.d.</i>	<i>n.d.</i>	3,36	3,39
Expansion tank	litres	8	8	8	8	8	12	12	12	12
Tank capacity	litres	200	200	200	200	200	340	340	340	340
Standard	Height	mm	<i>n.d.</i>	<i>n.d.</i>	1735	1735	1735	1735	1735	1735
	Length	mm	<i>n.d.</i>	<i>n.d.</i>	2090	2090	2090	2440	2440	3190 <sup>(5)</sup>
	Depth	mm	<i>n.d.</i>	<i>n.d.</i>	1183	1183	1183	1183	1183	1183
	Sound pressure @ 10 m Q=2	dB(A)	<i>n.d.</i>	<i>n.d.</i>	52	52	52	53,5	53,5	54,0
Low Noise	Height	mm	1735	1735	1735	1735	1735	1735	1823	1823
	Length	mm	2090	2090	2440	2440	2440	3190	3190	3540
	Depth	mm	1183	1183	1183	1183	1183	1183	1183	1653
	Sound pressure @ 10 m Q=2	dB(A)	42	42	44	44	44	45	45	49
Quiet	Height	mm	1720	1720	1720	1720	1720	1720	1823	1823
	Length	mm	2090	2090	2440	2440	2440	3190	3190	3540
	Depth	mm	1183	1183	1183	1183	1183	1183	1183	1653
	Sound pressure @ 10 m Q=2	dB(A)	39	39	41	41	41	42	42	41

LCE			16_	174 <sup>(4)</sup>	194	214	244	274	294	324
	Cooling capacity <sup>1</sup>	kW	155,0	162,0	186,6	209,0	236,9	271,6	295,5	313,9
	Total Input power <sup>1</sup>	kW	56,3	50,5	64,4	77,0	86,6	95,8	104,4	111,8
	Heating capacity <sup>2</sup>	kW	176,1	188,3	212,4	235,6	272,5	307,2	329,8	350,8
	Electrical input-heating mode <sup>2</sup>	kW	51,3	55,6	65,2	73,0	85,12	95,86	104,2	112,6
	EER efficiency pack 1		2,75	<i>n.d.</i>	<i>n.d.</i>	<i>n.d.</i>	<i>n.d.</i>	<i>n.d.</i>	<i>n.d.</i>	<i>n.d.</i>
	EER efficiency pack 2		2,75	<i>n.d.</i>	<i>n.d.</i>	<i>n.d.</i>	<i>n.d.</i>	<i>n.d.</i>	<i>n.d.</i>	<i>n.d.</i>
	EER efficiency pack 4		2,76	3,21	2,90	2,71	2,74	2,84	2,83	2,81
	ESEER efficiency pack 1		3,61	<i>n.d.</i>	<i>n.d.</i>	<i>n.d.</i>	<i>n.d.</i>	<i>n.d.</i>	<i>n.d.</i>	<i>n.d.</i>
	ESEER efficiency pack 2		3,87	<i>n.d.</i>	<i>n.d.</i>	<i>n.d.</i>	<i>n.d.</i>	<i>n.d.</i>	<i>n.d.</i>	<i>n.d.</i>
	ESEER efficiency pack 4		3,75	4,16	4,04	4,00	4,01	4,10	4,12	4,18
	COP efficiency pack 1		3,29	<i>n.d.</i>	<i>n.d.</i>	<i>n.d.</i>	<i>n.d.</i>	<i>n.d.</i>	<i>n.d.</i>	<i>n.d.</i>
	COP efficiency pack 2		3,30	<i>n.d.</i>	<i>n.d.</i>	<i>n.d.</i>	<i>n.d.</i>	<i>n.d.</i>	<i>n.d.</i>	<i>n.d.</i>
	COP efficiency pack 4		3,26	3,39	3,26	3,23	3,20	3,20	3,17	3,12
	Expansion tank	litres	12	25	25	25	25	25	25	25
	Tank capacity	litres	340	600	600	600	600	765	765	765
Standard	Height	mm	1735	1823	1823	1823	2223	2223	2223	2223
	Length	mm	3190 <sup>(5)</sup>	3540	3540	3540	3540	4206	4206	4206
	Depth	mm	1183	1653	1653	1653	1653	1653	1653	1653
	Sound pressure @ 10 m Q=2	dB(A)	54,0	54,8	54,8	54,8	54,8	56,0	56,0	56,0
Low Noise	Height	mm	1823	<i>n.d.</i>	1823	2223	2223	2223	2223	2223
	Length	mm	3540	<i>n.d.</i>	3540	3540	3540	4206	4206	4206
	Depth	mm	1653	<i>n.d.</i>	1653	1653	1653	1653	1653	1653
	Sound pressure @ 10 m Q=2	dB(A)	49	<i>n.d.</i>	49	49	50	51	51	51
Quiet	Height	mm	1823	<i>n.d.</i>	1823	2223	2223	2223	2223	2223
	Length	mm	3540	<i>n.d.</i>	3540	3540	3540	4206	4206	4206
	Depth	mm	1653	<i>n.d.</i>	1653	1653	1653	1653	1653	1653
	Sound pressure @ 10 m Q=2	dB(A)	41	<i>n.d.</i>	41	41	41	42	42	42

1 = ratings based on standard model with water 12/7°C air 35°C  
2 = ratings based on standard model with water 40/45°C air 7°C R.H. 90%  
3 = available only in L (low noise) and Q (quiet) models  
4 = not available in L (low noise) and Q (quiet) models  
5 = for the "efficiency pack 4" model Length = 3540 mm

## 15 SUMMARY TABLE OF WEIGHTS

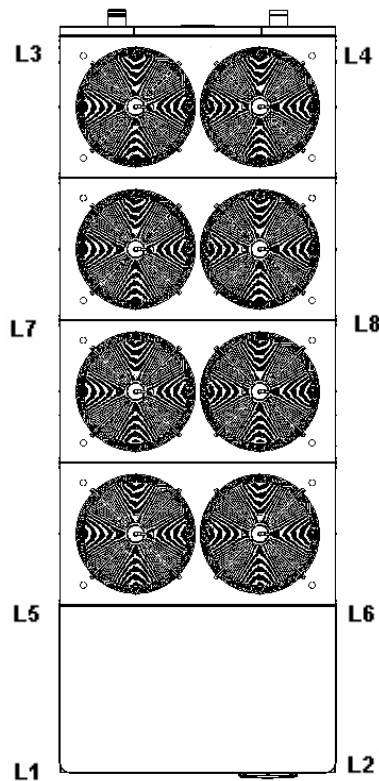

This drawing illustrates the points of the machine for which the **weights for the basic chiller and heat pump models** have been calculated. The values are shown in the following tables.

**Important note:** the weights of hydronic modules (C-H; with 2 pumps + reservoir, with 1 pump + reservoir, with 2 pumps, with 1 pump) must be added to the standard weights of the basic model (C-H; STD cooling only, STD heat pump).

*NB: all weights indicated above include the refrigerant charge and water contained in the hydraulic system (very important for determining the most suitable support for the unit (especially if equipped with a reservoir).*

To obtain the approximate weight of the unit when empty, subtract the weight in kg of the water contained in the reservoir – see table below. In other cases the water content is negligible for these purposes.

FRAME	LENGHT	DEPTH	HEIGHT	H2O in the buffer tank [Kg]
1	2090	1183	1735	200
2	2440	1183	1735	220
3	3190	1183	1735	340
3+	3540	1183	1735	340
4	3540	1653	1823	600
5	3540	1653	2223	600
6	4206	1653	2223	765

## 15.1 TOTAL STD WEIGHTS C-H

### ➤ LCE weights - cooling only

	CS-CL-CQ	CS-CL-CQ	CS	CL-CQ	CS	CL-CQ	CS	CL-CQ	CS	CL-CQ	CS
<b>SIZE</b>	<b>42</b>	<b>52</b>	<b>62</b>	<b>62</b>	<b>72</b>	<b>72</b>	<b>82</b>	<b>82</b>	<b>91-92</b>	<b>91-92</b>	<b>101-102</b>
<b>FRAME</b>	<b>1</b>	<b>1</b>	<b>1</b>	<b>2</b>	<b>1</b>	<b>2</b>	<b>1</b>	<b>2</b>	<b>2</b>	<b>3</b>	<b>2</b>
<b>total [kg]</b>	<b>525</b>	<b>525</b>	<b>540</b>	<b>630</b>	<b>570</b>	<b>635</b>	<b>650</b>	<b>700</b>	<b>730</b>	<b>905</b>	<b>730</b>
L1	197	197	203	236	214	238	244	263	274	170	274
L2	197	197	203	236	214	238	244	263	274	170	274
L3	66	66	68	79	71	79	81	88	91	113	91
L4	66	66	68	79	71	79	81	88	91	113	91
L5										170	
L6										170	
L7											
L8											
	CL-CQ	CS	CS	CS	CL-CQ	CS	CS	CS	CL-CQ	CL-CQ	CL-CQ
<b>SIZE</b>	<b>101-102</b>	<b>121-122</b>	<b>141-142</b>	<b>161-162</b>	<b>94-104</b>	<b>124</b>	<b>144</b>	<b>164</b>	<b>121-122</b>	<b>124</b>	<b>141-142</b>
<b>FRAME</b>	<b>3</b>	<b>3</b>	<b>3</b>	<b>3</b>	<b>3+</b>	<b>3+</b>	<b>3+</b>	<b>3+</b>	<b>4</b>	<b>4</b>	<b>4</b>
<b>total [kg]</b>	<b>915</b>	<b>1010</b>	<b>1055</b>	<b>1085</b>	<b>980</b>	<b>1050</b>	<b>1070</b>	<b>1220</b>	<b>1260</b>	<b>1275</b>	<b>1310</b>
L1	172	189	198	203	147	158	161	183	189	191	197
L2	172	189	198	203	147	158	161	183	189	191	197
L3	114	126	132	136	98	105	107	122	126	128	131
L4	114	126	132	136	98	105	107	122	126	128	131
L5	172	189	198	203	147	158	161	183	189	191	197
L6	172	189	198	203	147	158	161	183	189	191	197
L7					98	105	107	122	126	128	131
L8					98	105	107	122	126	128	131
	CL-CQ	CL-CQ	CL-CQ	CS	CS-CL-CQ	CS	CL-CQ	CS-CL-CQ	CS-CL-CQ	CS-CL-CQ	CS-CL-CQ
<b>SIZE</b>	<b>144</b>	<b>161-162</b>	<b>164</b>	<b>174</b>	<b>194</b>	<b>214</b>	<b>214</b>	<b>244</b>	<b>274</b>	<b>294</b>	<b>324</b>
<b>FRAME</b>	<b>4</b>	<b>4</b>	<b>4</b>	<b>4</b>	<b>4</b>	<b>4</b>	<b>5</b>	<b>5</b>	<b>6</b>	<b>6</b>	<b>6</b>
<b>total [kg]</b>	<b>1290</b>	<b>1330</b>	<b>1440</b>	<b>1440</b>	<b>1460</b>	<b>1470</b>	<b>1510</b>	<b>1620</b>	<b>1880</b>	<b>1912</b>	<b>1947</b>
L1	194	200	216	216	219	221	227	243	353	359	365
L2	194	200	216	216	219	221	227	243	353	359	365
L3	129	133	144	144	146	147	151	162	235	239	243
L4	129	133	144	144	146	147	151	162	235	239	243
L5	194	200	216	216	219	221	227	243	353	359	365
L6	194	200	216	216	219	221	227	243	353	359	365
L7	129	133	144	144	146	147	151	162			
L8	129	133	144	144	146	147	151	162			

➤ LCE weights - heat pump

	HS-HL-HQ	HS-HL-HQ	HS	HL-HQ	HS	HL-HQ	HS	HL-HQ	HS	HL-HQ	HS
<b>SIZE</b>	<b>42</b>	<b>52</b>	<b>62</b>	<b>62</b>	<b>72</b>	<b>72</b>	<b>82</b>	<b>82</b>	<b>91-92</b>	<b>91-92</b>	<b>101-102</b>
<b>FRAME</b>	<b>1</b>	<b>1</b>	<b>1</b>	<b>2</b>	<b>1</b>	<b>2</b>	<b>1</b>	<b>2</b>	<b>2</b>	<b>3</b>	<b>2</b>
<b>total [kg]</b>	<b>545</b>	<b>545</b>	<b>585</b>	<b>650</b>	<b>585</b>	<b>655</b>	<b>675</b>	<b>735</b>	<b>755</b>	<b>940</b>	<b>760</b>
L1	204	204	219	244	219	246	253	276	283	176	285
L2	204	204	219	244	219	246	253	276	283	176	285
L3	68	68	73	81	73	82	84	92	94	118	95
L4	68	68	73	81	73	82	84	92	94	118	95
L5										176	
L6										176	
L7											
L8											
	HL-HQ	HS	HS	HS	HL-HQ	HS	HS	HS	HL-HQ	HL-HQ	HL-HQ
<b>SIZE</b>	<b>101-102</b>	<b>121-122</b>	<b>141-142</b>	<b>161-162</b>	<b>94-104</b>	<b>124</b>	<b>144</b>	<b>164</b>	<b>121-122</b>	<b>124</b>	<b>141-142</b>
<b>FRAME</b>	<b>3</b>	<b>3</b>	<b>3</b>	<b>3</b>	<b>3+</b>	<b>3+</b>	<b>3+</b>	<b>3+</b>	<b>4</b>	<b>4</b>	<b>4</b>
<b>total [kg]</b>	<b>945</b>	<b>1050</b>	<b>1100</b>	<b>1155</b>	<b>1020</b>	<b>1090</b>	<b>1120</b>	<b>1270</b>	<b>1305</b>	<b>1315</b>	<b>1350</b>
L1	177	197	206	217	153	164	168	191	196	197	203
L2	177	197	206	217	153	164	168	191	196	197	203
L3	118	131	138	144	102	109	112	127	131	132	135
L4	118	131	138	144	102	109	112	127	131	132	135
L5	177	197	206	217	153	164	168	191	196	197	203
L6	177	197	206	217	153	164	168	191	196	197	203
L7					102	109	112	127	131	132	135
L8					102	109	112	127	131	132	135
	HL-HQ	HL-HQ	HL-HQ	HS	HS-HL-HQ	HS	HL-HQ	HS-HL-HQ	HS-HL-HQ	HS-HL-HQ	HS-HL-HQ
<b>SIZE</b>	<b>144</b>	<b>161-162</b>	<b>164</b>	<b>174</b>	<b>194</b>	<b>214</b>	<b>214</b>	<b>244</b>	<b>274</b>	<b>294</b>	<b>324</b>
<b>FRAME</b>	<b>4</b>	<b>4</b>	<b>4</b>	<b>4</b>	<b>4</b>	<b>4</b>	<b>5</b>	<b>5</b>	<b>6</b>	<b>6</b>	<b>6</b>
<b>total [kg]</b>	<b>1345</b>	<b>1375</b>	<b>1495</b>	<b>1495</b>	<b>1515</b>	<b>1530</b>	<b>1590</b>	<b>1690</b>	<b>1952</b>	<b>1987</b>	<b>2038</b>
L1	202	206	224	224	227	230	239	254	366	373	382
L2	202	206	224	224	227	230	239	254	366	373	382
L3	135	138	150	150	152	153	159	169	244	248	255
L4	135	138	150	150	152	153	159	169	244	248	255
L5	202	206	224	224	227	230	239	254	366	373	382
L6	202	206	224	224	227	230	239	254	366	373	382
L7	135	138	150	150	152	153	159	169			
L8	135	138	150	150	152	153	159	169			

## 15.2 WEIGHTS OF HYDRONIC MODULES C-H

➤ Weights with 2 pumps + full storage reservoir (to be added to the STD weight)

	S-L-Q	S-L-Q	S	L-Q	S	L-Q	S	L-Q	S	L-Q	S
<b>SIZE</b>	<b>42</b>	<b>52</b>	<b>62</b>	<b>62</b>	<b>72</b>	<b>72</b>	<b>82</b>	<b>82</b>	<b>91-92</b>	<b>91-92</b>	<b>101-102</b>
<b>FRAME</b>	<b>1</b>	<b>1</b>	<b>1</b>	<b>2</b>	<b>1</b>	<b>2</b>	<b>1</b>	<b>2</b>	<b>2</b>	<b>3</b>	<b>2</b>
<b>total [kg]</b>	<b>402</b>	<b>402</b>	<b>402</b>	<b>450</b>	<b>402</b>	<b>450</b>	<b>402</b>	<b>450</b>	<b>500</b>	<b>630</b>	<b>500</b>
L1	101	101	101	113	101	113	101	113	125	32	125
L2	101	101	101	113	101	113	101	113	125	32	125
L3	101	101	101	113	101	113	101	113	125	142	125
L4	101	101	101	113	101	113	101	113	125	142	125
L5										142	
L6										142	
L7											
L8											
	L-Q	S	S	S	L-Q	S	S	S	L-Q	L-Q	L-Q
<b>SIZE</b>	<b>101-102</b>	<b>121-122</b>	<b>141-142</b>	<b>161-162</b>	<b>94-104</b>	<b>124</b>	<b>144</b>	<b>164</b>	<b>121-122</b>	<b>124</b>	<b>141-142</b>
<b>FRAME</b>	<b>3</b>	<b>3</b>	<b>3</b>	<b>3</b>	<b>3+</b>	<b>3+</b>	<b>3+</b>	<b>3+</b>	<b>4</b>	<b>4</b>	<b>4</b>
<b>total [kg]</b>	<b>630</b>	<b>660</b>	<b>660</b>	<b>660</b>	<b>650</b>	<b>680</b>	<b>680</b>	<b>680</b>	<b>875</b>	<b>875</b>	<b>875</b>
L1	32	33	33	33	0	0	0	0	0	0	0
L2	32	33	33	33	0	0	0	0	0	0	0
L3	142	149	149	149	98	102	102	102	131	131	131
L4	142	149	149	149	98	102	102	102	131	131	131
L5	142	149	149	149	98	102	102	102	131	131	131
L6	142	149	149	149	98	102	102	102	131	131	131
L7					130	136	136	136	175	175	175
L8					130	136	136	136	175	175	175
	L-Q	L-Q	L-Q	S	S-L-Q	S	L-Q	S-L-Q	S-L-Q	S-L-Q	S-L-Q
<b>SIZE</b>	<b>144</b>	<b>161-162</b>	<b>164</b>	<b>174</b>	<b>194</b>	<b>214</b>	<b>214</b>	<b>244</b>	<b>274</b>	<b>294</b>	<b>324</b>
<b>FRAME</b>	<b>4</b>	<b>4</b>	<b>4</b>	<b>4</b>	<b>4</b>	<b>4</b>	<b>5</b>	<b>5</b>	<b>6</b>	<b>6</b>	<b>6</b>
<b>total [kg]</b>	<b>875</b>	<b>875</b>	<b>875</b>	<b>875</b>	<b>908</b>	<b>908</b>	<b>908</b>	<b>950</b>	<b>1115</b>	<b>1115</b>	<b>1115</b>
L1	0	0	0	0	0	0	0	0	186	186	186
L2	0	0	0	0	0	0	0	0	186	186	186
L3	131	131	131	131	136	136	136	143	186	186	186
L4	131	131	131	131	136	136	136	143	186	186	186
L5	131	131	131	131	136	136	136	143	186	186	186
L6	131	131	131	131	136	136	136	143	186	186	186
L7	175	175	175	175	182	182	182	190			
L8	175	175	175	175	182	182	182	190			

➤ **Weights with 1 pump + full storage reservoir (to be added to the STD weight)**

	S-L-Q	S-L-Q	S	L-Q	S	L-Q	S	L-Q	S	L-Q	S
<b>SIZE</b>	<b>42</b>	<b>52</b>	<b>62</b>	<b>62</b>	<b>72</b>	<b>72</b>	<b>82</b>	<b>82</b>	<b>91-92</b>	<b>91-92</b>	<b>101-102</b>
<b>FRAME</b>	<b>1</b>	<b>1</b>	<b>1</b>	<b>2</b>	<b>1</b>	<b>2</b>	<b>1</b>	<b>2</b>	<b>2</b>	<b>3</b>	<b>2</b>
<b>total [kg]</b>	<b>337</b>	<b>337</b>	<b>337</b>	<b>352</b>	<b>337</b>	<b>352</b>	<b>337</b>	<b>367</b>	<b>408</b>	<b>521</b>	<b>408</b>
<b>L1</b>	84	84	84	88	84	88	84	92	102	26	102
<b>L2</b>	84	84	84	88	84	88	84	92	102	26	102
<b>L3</b>	84	84	84	88	84	88	84	92	102	117	102
<b>L4</b>	84	84	84	88	84	88	84	92	102	117	102
<b>L5</b>										117	
<b>L6</b>										117	
<b>L7</b>											
<b>L8</b>											
	L-Q	S	S	S	L-Q	S	S	S	L-Q	L-Q	L-Q
<b>SIZE</b>	<b>101-102</b>	<b>121-122</b>	<b>141-142</b>	<b>161-162</b>	<b>94-104</b>	<b>124</b>	<b>144</b>	<b>164</b>	<b>121-122</b>	<b>124</b>	<b>141-142</b>
<b>FRAME</b>	<b>3</b>	<b>3</b>	<b>3</b>	<b>3</b>	<b>3+</b>	<b>3+</b>	<b>3+</b>	<b>3+</b>	<b>4</b>	<b>4</b>	<b>4</b>
<b>total [kg]</b>	<b>521</b>	<b>571</b>	<b>571</b>	<b>571</b>	<b>577,5</b>	<b>591</b>	<b>591</b>	<b>591</b>	<b>780</b>	<b>780</b>	<b>780</b>
<b>L1</b>	26	29	29	29	0	0	0	0	0	0	0
<b>L2</b>	26	29	29	29	0	0	0	0	0	0	0
<b>L3</b>	117	128	128	128	87	89	89	89	117	117	117
<b>L4</b>	117	128	128	128	87	89	89	89	117	117	117
<b>L5</b>	117	128	128	128	87	89	89	89	117	117	117
<b>L6</b>	117	128	128	128	87	89	89	89	117	117	117
<b>L7</b>					116	118	118	118	156	156	156
<b>L8</b>					116	118	118	118	156	156	156
	L-Q	L-Q	L-Q	S	S-L-Q	S	L-Q	S-L-Q	S-L-Q	S-L-Q	S-L-Q
<b>SIZE</b>	<b>144</b>	<b>161-162</b>	<b>164</b>	<b>174</b>	<b>194</b>	<b>214</b>	<b>214</b>	<b>244</b>	<b>274</b>	<b>294</b>	<b>324</b>
<b>FRAME</b>	<b>4</b>	<b>4</b>	<b>4</b>	<b>4</b>	<b>4</b>	<b>4</b>	<b>5</b>	<b>5</b>	<b>6</b>	<b>6</b>	<b>6</b>
<b>total [kg]</b>	<b>780</b>	<b>780</b>	<b>780</b>	<b>768</b>	<b>816</b>	<b>816</b>	<b>816</b>	<b>849</b>	<b>1014</b>	<b>1014</b>	<b>1014</b>
<b>L1</b>	0	0	0	0	0	0	0	0	169	169	169
<b>L2</b>	0	0	0	0	0	0	0	0	169	169	169
<b>L3</b>	117	117	117	115	122	122	122	127	169	169	169
<b>L4</b>	117	117	117	115	122	122	122	127	169	169	169
<b>L5</b>	117	117	117	115	122	122	122	127	169	169	169
<b>L6</b>	117	117	117	115	122	122	122	127	169	169	169
<b>L7</b>	156	156	156	154	163	163	163	170			
<b>L8</b>	156	156	156	154	163	163	163	170			

➤ Weights with 2 pumps (to be added to the STD weight)

	S-L-Q	S-L-Q	S	L-Q	S	L-Q	S	L-Q	S	L-Q	S
<b>SIZE</b>	<b>42</b>	<b>52</b>	<b>62</b>	<b>62</b>	<b>72</b>	<b>72</b>	<b>82</b>	<b>82</b>	<b>91-92</b>	<b>91-92</b>	<b>101-102</b>
<b>FRAME</b>	1	1	1	2	1	2	1	2	2	3	2
<b>total [kg]</b>	<b>154</b>	<b>154</b>	<b>154</b>	<b>197</b>	<b>154</b>	<b>197</b>	<b>154</b>	<b>178</b>	<b>190</b>	<b>212</b>	<b>190</b>
L1	39	39	39	49	39	49	39	45	48	11	48
L2	39	39	39	49	39	49	39	45	48	11	48
L3	39	39	39	49	39	49	39	45	48	48	48
L4	39	39	39	49	39	49	39	45	48	48	48
L5										48	
L6										48	
L7											
L8											
	L-Q	S	S	S	L-Q	S	S	S	L-Q	L-Q	L-Q
<b>SIZE</b>	<b>101-102</b>	<b>121-122</b>	<b>141-142</b>	<b>161-162</b>	<b>94-104</b>	<b>124</b>	<b>144</b>	<b>164</b>	<b>121-122</b>	<b>124</b>	<b>141-142</b>
<b>FRAME</b>	3	3	3	3	3+	3+	3+	3+	4	4	4
<b>total [kg]</b>	<b>212</b>	<b>212</b>	<b>212</b>	<b>212</b>	<b>190</b>	<b>212</b>	<b>212</b>	<b>212</b>	<b>220</b>	<b>220</b>	<b>220</b>
L1	11	11	11	11	0	0	0	0	0	0	0
L2	11	11	11	11	0	0	0	0	0	0	0
L3	48	48	48	48	29	32	32	32	33	33	33
L4	48	48	48	48	29	32	32	32	33	33	33
L5	48	48	48	48	29	32	32	32	33	33	33
L6	48	48	48	48	29	32	32	32	33	33	33
L7					38	42	42	42	44	44	44
L8					38	42	42	42	44	44	44
	L-Q	L-Q	L-Q	S	S-L-Q	S	L-Q	S-L-Q	S-L-Q	S-L-Q	S-L-Q
<b>SIZE</b>	<b>144</b>	<b>161-162</b>	<b>164</b>	<b>174</b>	<b>194</b>	<b>214</b>	<b>214</b>	<b>244</b>	<b>274</b>	<b>294</b>	<b>324</b>
<b>FRAME</b>	4	4	4	4	4	4	5	5	6	6	6
<b>total [kg]</b>	<b>220</b>	<b>220</b>	<b>220</b>	<b>236</b>	<b>236</b>	<b>236</b>	<b>236</b>	<b>248</b>	<b>248</b>	<b>248</b>	<b>248</b>
L1	0	0	0	0	0	0	0	0	41	41	41
L2	0	0	0	0	0	0	0	0	41	41	41
L3	33	33	33	35	35	35	35	37	41	41	41
L4	33	33	33	35	35	35	35	37	41	41	41
L5	33	33	33	35	35	35	35	37	41	41	41
L6	33	33	33	35	35	35	35	37	41	41	41
L7	44	44	44	47	47	47	47	50			
L8	44	44	44	47	47	47	47	50			



➤ Weights with 1 pump (to be added to the STD weight)

	S-L-Q	S-L-Q	S	L-Q	S	L-Q	S	L-Q	S	L-Q	S
<b>SIZE</b>	<b>42</b>	<b>52</b>	<b>62</b>	<b>62</b>	<b>72</b>	<b>72</b>	<b>82</b>	<b>82</b>	<b>91-92</b>	<b>91-92</b>	<b>101-102</b>
<b>FRAME</b>	<b>1</b>	<b>1</b>	<b>1</b>	<b>2</b>	<b>1</b>	<b>2</b>	<b>1</b>	<b>2</b>	<b>2</b>	<b>3</b>	<b>2</b>
<b>total [kg]</b>	<b>116</b>	<b>116</b>	<b>116</b>	<b>148</b>	<b>116</b>	<b>148</b>	<b>116</b>	<b>134</b>	<b>143</b>	<b>159</b>	<b>143</b>
L1	29	29	29	37	29	37	29	33	36	8	36
L2	29	29	29	37	29	37	29	33	36	8	36
L3	29	29	29	37	29	37	29	33	36	36	36
L4	29	29	29	37	29	37	29	33	36	36	36
L5										36	
L6										36	
L7											
L8											
	L-Q	S	S	S	L-Q	S	S	S	L-Q	L-Q	L-Q
<b>SIZE</b>	<b>101-102</b>	<b>121-122</b>	<b>141-142</b>	<b>161-162</b>	<b>94-104</b>	<b>124</b>	<b>144</b>	<b>164</b>	<b>121-122</b>	<b>124</b>	<b>141-142</b>
<b>FRAME</b>	<b>3</b>	<b>3</b>	<b>3</b>	<b>3</b>	<b>3+</b>	<b>3+</b>	<b>3+</b>	<b>3+</b>	<b>4</b>	<b>4</b>	<b>4</b>
<b>total [kg]</b>	<b>159</b>	<b>159</b>	<b>159</b>	<b>159</b>	<b>142,5</b>	<b>159</b>	<b>159</b>	<b>159</b>	<b>165</b>	<b>165</b>	<b>165</b>
L1	8	8	8	8	0	0	0	0	0	0	0
L2	8	8	8	8	0	0	0	0	0	0	0
L3	36	36	36	36	21	24	24	24	25	25	25
L4	36	36	36	36	21	24	24	24	25	25	25
L5	36	36	36	36	21	24	24	24	25	25	25
L6	36	36	36	36	21	24	24	24	25	25	25
L7					29	32	32	32	33	33	33
L8					29	32	32	32	33	33	33
	L-Q	L-Q	L-Q	S	S-L-Q	S	L-Q	S-L-Q	S-L-Q	S-L-Q	S-L-Q
<b>SIZE</b>	<b>144</b>	<b>161-162</b>	<b>164</b>	<b>174</b>	<b>194</b>	<b>214</b>	<b>214</b>	<b>244</b>	<b>274</b>	<b>294</b>	<b>324</b>
<b>FRAME</b>	<b>4</b>	<b>4</b>	<b>4</b>	<b>4</b>	<b>4</b>	<b>4</b>	<b>5</b>	<b>5</b>	<b>6</b>	<b>6</b>	<b>6</b>
<b>total [kg]</b>	<b>165</b>	<b>165</b>	<b>165</b>	<b>177</b>	<b>177</b>	<b>177</b>	<b>177</b>	<b>186</b>	<b>186</b>	<b>186</b>	<b>186</b>
L1	0	0	0	0	0	0	0	0	31	31	31
L2	0	0	0	0	0	0	0	0	31	31	31
L3	25	25	25	27	27	27	27	28	31	31	31
L4	25	25	25	27	27	27	27	28	31	31	31
L5	25	25	25	27	27	27	27	28	31	31	31
L6	25	25	25	27	27	27	27	28	31	31	31
L7	33	33	33	35	35	35	35	37			
L8	33	33	33	35	35	35	35	37			

### 15.3 PUMPING AND STORAGE SYSTEMS

LCE units may be equipped with 6 types of pumping systems, complete with expansion tank and storage reservoirs

single standard pump

single uprated pump

standard pump and back-up pump

uprated pump and back-up pump

standard pump for combined operation

uprated pump for combined operation.

In the case of pump systems including a back-up pump, the microprocessor controls the pumps in such a way as to equally divide the hours of operation, changing over the pumps in the event of a fault.

LCE		042	052	062	072	082	091_2_4
Standard pump type		A	A	B	B	B	C
Available head, LCE with standard pump (nominal flow rate)	kPa	79	74	123	117	116	159
Rated electrical output, standard pump	kW	0.55	0.55	0.75	0.75	0.75	1.50
Operating current, standard pump	A	1.7	1.7	2.3	2.3	2.3	4.3
Uprated pump type		C	C	D	D	D	E
Available head, LCE with uprated pump (nominal flow rate)	kPa	183	178	138	224	221	229
Rated electrical output, uprated pump	kW	1.50	1.50	2.20	2.20	2.20	3.00
Operating current, uprated pump	A	4.3	4.3	5.3	5.3	5.3	6.6
Inertial buffer tank capacity	dm <sup>3</sup>	218	218	315	315	315	485
Expansion tank	dm <sup>3</sup>	8	8	8	8	8	12
LCE		101_2_4	121_2_4	141_2_4	161_2_4	174	194
Standard pump type		C	C	C	D	D	E
Available head, LCE with standard pump (nominal flow rate)	kPa	137	131	126	143	138	146
Rated electrical output, standard pump	kW	1.50	1.50	1.50	2.20	2.20	3.00
Operating current, standard pump	A	4.3	4.3	4.3	5.3	5.3	6.6
Uprated pump type		E	F	F	F	G	G
Available head, LCE with uprated pump (nominal flow rate)	kPa	217	264	258	238	279	281
Rated electrical output, uprated pump	kW	3.00	4.00	4.00	4.00	7.50	7.50
Operating current, uprated pump	A	6.6	9.6	9.6	9.6	16.0	16.0
Inertial buffer tank capacity	dm <sup>3</sup>	485	600	600	600	600	765
Expansion tank	dm <sup>3</sup>	12	24	24	24	24	24
LCE		214	244	274	294	324	
Standard pump type		E	E	F	F	F	
Available head, LCE with standard pump (nominal flow rate)	kPa	139	131	174.9	168.9	156.2	
Rated electrical output, standard pump	kW	3.00	3.00	4.00	4.00	4.00	
Operating current, standard pump	A	6.6	6.6	9.2	9.2	9.2	
Uprated pump type		G	G	H	H	H	
Available head, LCE with uprated pump (nominal flow rate)	kPa	278	261	292.6	286.6	273.9	
Rated electrical output, uprated pump	kW	7.50	7.50	7.50	7.50	7.50	
Operating current, uprated pump	A	16.0	16.0	15.5	15.5	15.5	
Inertial buffer tank capacity	dm <sup>3</sup>	765	765	765	765	765	
Expansion tank	dm <sup>3</sup>	24	24	24	24	24	

In the case of the dual pump - combined operation option, the advanced type of microprocessor is mandatory, since it controls the switching on of the second pump according to the number of capacity steps required at every instant; this means that the unit will operate in a cost-effective manner for most of its life given that, based on well-known analyses, chillers operate under part load conditions for 97% of their lifetime.

LCE





All rights reserved.

No part of this publication may be reproduced without the prior written permission of Lennox. Lennox S.p.A. reserves the right to change the specifications and other information contained herein without notice. In no case shall Lennox be responsible for damage or injury caused to property or persons either directly or indirectly as a result of the information contained herein.