



# Installation, operating and maintenance **AIR COOLED CHILLERS**



- Providing indoor climate comfort



## TABLE OF CONTENTS

# AIR COOLED CHILLERS AND SPLIT UNITS



## INSTALLATION OPERATION MAINTENANCE MANUAL

Ref: CHILLERS\_IOM-0708-E

*The present manual applies to the following CHILLER ranges:*

ECOLOGIC range: WA  
MCC range  
NEOSYS range NAC – NAH

Special unit n°

<p><i>Our company is a member of the Eurovent Certification Programme, all LENNOX chillers are tested and rated in accordance with Eurovent certification program,</i></p>	
<p>Our products comply with the European standards,</p>	
<p><i>Product designed and manufactured under a quality management system certified to AFAQ ISO 9001 by AFAQ,</i></p>	

**LENNOX** have been providing environmental solutions since 1895, our range of air cooled chillers continues to meet the standards that have made **LENNOX** a household name. Flexible design solutions to meet **YOUR** needs and uncompromising attention to detail. Engineered to last, simple to maintain and Quality that comes as standard. Information on local contacts at [www.lennox europe.com](http://www.lennox europe.com).

All the technical and technological information contained in this manual, including any drawing and technical descriptions provided by us, remain the property of Lennox and must not be utilised (except in operation of this product), reproduced, issued to or made available to third parties without the prior written agreement of Lennox.

## TABLE OF CONTENTS

<b>1 - INTRODUCTION</b> .....	<b>3</b>
<b>PED Declaration</b> .....	<b>4</b>
<b>F Gas Regulation</b> .....	<b>5</b>
<b>2 - WARRANTY</b> .....	<b>6</b>
2.1 – Safety recommendations.....	6
<b>3 - INSTALLATION</b> .....	<b>8</b>
3.1 - Transport .....	8
3.2 - Lifting.....	9
3.3 - Lay-out and installation requirements .....	11
3.4 - Water connections .....	12
3.5 - Electrical connections .....	16
3.6 - Sound levels .....	16
3.7 - Connections of split units .....	17
3.8 - Ducted units installation .....	22
<b>4 - PRELIMINARY CHECKS</b> .....	<b>23</b>
4.1 - Limits.....	23
4.2 - Refrigeration circuit checks and recommendations.....	23
4.3 - Hydraulic system installation ckecks.....	23
4.4 - Installation of external hydraulic components (supplied loose by LENNOX) ...	23
4.5 - Check list before start-up .....	24
<b>5 - UNIT START-UP</b> .....	<b>27</b>
5.1 - Checks to be made during start-up.....	27
5.2 - Oil charge .....	28
5.3 - Refrigerant charge .....	28
<b>6 - OPERATION</b> .....	<b>29</b>
6.1 - CLIMATIC™ control.....	29
6.2 - Unit operation .....	29
<b>7. MAINTENANCE</b> .....	<b>34</b>
7.1 - Weekly maintenance .....	34
7.2 - Annual maintenance .....	35
7.3 - Cleaning the condenser .....	35
7.4 - Compressor oil drainage .....	36
7.5 - Important .....	36
<b>8 TROUBLESHOOTING - REPAIRS</b> .....	<b>37</b>
8.1 List of the most common problems .....	38
8.2 Control devices .....	43
8.3 Manufacturer’s recommended inspections.....	44
<b>ANNEXES</b> .....	<b>50</b>

## INTRODUCTION

### 1 - INTRODUCTION

**You must read and be familiar with this operating manual prior to commission the chiller.**

**Please closely follow the instructions.**

We would like to stress the importance of training with respect to the correct handling of the chiller. Please consult Lennox on the options available in this field.

It is important that this manual be stored in a permanent location in the vicinity of the chiller.

---

Text	Important general instruction
------	-------------------------------

---



Danger of Injury or damage to the chiller

This manual contains important instructions regarding the commissioning of the chiller. It also includes important instructions to prevent personal injury and damage to the machine during operation. Furthermore, in order to promote fault-free operation of the chiller, maintenance information has been included.

Please do not hesitate to contact one of our employees should you require further information on specific chiller subjects.

Order related documentation will be forwarded under separate cover.

This documentation consists of :

- **CE declaration.**
- **Operating manual for control system.**
- **Installation Operating manual**
- **Wiring diagram.**
- **Refrigerant flow diagram (except for WA-RA-WAH-LCH)**
- **Unit detail are given on unit nameplate.**

The data published in this manual is based on the most recent information available. It is supplied conditional to later modifications. We reserve the right to modify the construction and/or design of our chillers, at any time, without prior notification or obligation to adapt previous supplies accordingly.



**Any work on the Chiller should be carried out by trained and licensed competent technician.**

**The following risks are present on the unit:**

- **risk of electrical shock**
- **risk of injury from rotating parts**
- **risk of injury from sharp edges and heavy weight**
- **risk of injury from high pressure gas**
- **risk of injury from high and low temperatures components.**

**It is expected that all works on equipment be carried out in accordance with all local standards and norms. It is expected that all works are carried out with good working practices.**

## PED DECLARATION

**All Units are compliant with the PED directive 97-23-CE.  
The following note must be followed carefully**

### IMPORTANT NOTICE

***All work on the unit must be carried out by a qualified and authorised employee.***

Non-compliance with the following instructions may result in injury or serious accidents.

***Work on the unit:***

- . The unit shall be isolated from the electrical supply by disconnection and locking using the main isolating switch.
- . Workers shall wear the appropriate personal protective equipment (helmet, gloves, glasses, etc.).

***Work on the electrical system:***

- . Work on electric components shall be performed with the power off (see below) by employees having valid electrical qualification and authorisation.

***Work on the refrigerating circuit(s):***

- . Monitoring of the pressures, draining and filling of the system under pressure shall be carried out using connections provided for this purpose and suitable equipment.
- . To prevent the risk of explosion due to spraying of coolant and oil, the relevant circuit shall be drained and at zero pressure before any disassembly or unbrazing of the refrigerating parts takes place.
- . There is a residual risk of pressure build-up by degassing the oil or by heating the exchangers after the circuit has been drained. Zero pressure shall be maintained by venting the drain connection to the atmosphere on the low pressure side.
- . The brazing shall be carried out by a qualified brazer. The brazing shall comply with the standard NF EN1044 (minimum 30% silver).

***Replacing components:***

- . In order to maintain CE marking compliance, replacement of components shall be carried out using spare parts, or using parts approved by Lennox.
- . Only the coolant shown on the manufacturer's nameplate shall be used, to the exclusion of all other products (mix of coolants, hydrocarbons, etc.).

### **CAUTION:**

**In the event of fire, refrigerating circuits can cause an explosion and spray coolant gas and oil.**

## F Gas Regulation

### EC Regulation No 842/2006 on fluorinated greenhouse gases

*Operators of refrigeration equipments must comply with the 6 main obligations defined in the F Gas Regulation*

OBLIGATION	Applicability
Recovery of F gases during plant servicing and maintenance and at the end of plant life.	All stationary systems
Use adequately trained staff to carry out installation, servicing and maintenance and leakage checking.	All stationary systems
NEW equipment shall be labelled.	All stationary systems
Take steps to prevent F gas leakage and repair detected leakage as soon as possible.	All stationary systems
Regularly check for leakage. <i>06 kg or more</i> : at least once every 12 months <i>30 kg or more</i> : at least once every 6 months <i>300 kg or more</i> : at least once every 3 months	Hermetically sealed systems > 6kg
Keep certain records about refrigeration plant that uses F gases. (refer to the start up and Maintenance Log book at the end of this document)	Stationary systems > 3kg
Fit and check automatic leak detection system.	Stationary systems > 300kg



Non compliance with these requirements is an offence and liable of financial penalties. Moreover, in case of problem it is mandatory to prove to the insurance company that the equipment complies with the F gas Regulation.

## WARRANTY

### 2 - WARRANTY

The warranty of the chillers is subject to the warranty definitions as agreed upon in the order. It is expected that the design and installation of the unit utilises good working practices.

The warranty will be legally null and void if:

- *Service and maintenance have not been executed in accordance with the regulations; repairs have not been carried out by Lennox personnel or have been implemented without prior written permission by Lennox.*
- *Modifications have been made to the equipment without prior written permission by Lennox.*
- *Settings and protections have been modified without prior written permission by Lennox.*
- *Non-original or other than the prescribed refrigerants or lubricants are used.*
- *The equipment has not been installed and/or connected in accordance with the installation instructions.*
- *The equipment is being used improperly, incorrectly, negligently or not in accordance with its nature and/or purpose.*
- *A flow switch protection device is not fitted.*
- *An appropriate filtration is not fitted close to the water inlet of the chiller.*

Under these circumstances Lennox is indemnified from any product liability claims from third parties. In the event of a warranty claim the machine serial number and Lennox order number must be quoted.

#### 2.1 – SAFETY RECOMMENDATIONS

The safety information contained in this manual is provided as a guide for the safe handling of this installation. Lennox does not vouch for the completeness of this information and can therefore not accept liability for any possible omissions.

In the air cooled chillers, heat is being transported by a pressurised refrigerant, with changes in pressure and temperature. Fans have been provided to discharge heat into the environment. The protection of operating and maintenance personnel was central in the design of the air cooled chiller. Safety features have been included to prevent excessive pressure in the system. Sheet metal parts have been fitted to prevent inadvertent contact with (hot) pipes. The fans are equipped with protective grids and the electrical control panel is completely touch-proof. This excludes some parts operating at a safe voltage (< 24 Volt). The service panels can only be opened using tools.

***Notwithstanding that the air cooled chillers are equipped with extensive safety and protection features, the up most care and attention is needed when carrying out operations on the machine.***

***Make sure to get every safety precautions such as: individual protections (gloves, glasses, protective clothes, safety shoes...), appropriate tooling, appropriate fire extinguishers for the system and the refrigerant type within easy reach...***

***Make also sure that technicians are well trained to work on these units, and get necessary qualifications (electrical, frigorific, local rules...). Any particular operation such as welding, soldering, or electrical works must be done by properly qualified technicians.***

***It is essential to follow non exhaustive recommendations hereunder:***

- ***Never work on a unit that is still energized.***
- ***Any manipulation (opening or closing) of a shut-off valve must be carried out by a qualified and authorised engineer. These procedures must be carried out with the unit shut-down.***
- ***Never work on any of the electrical components, until the general power supply to the unit has been cut. During any maintenance operations on the unit, lock the power supply circuit in the open position ahead of the machine. If the work is interrupted, check the lock before resuming the work.***

***WARNING: Even if the unit has been switched off, the power circuit remains energized, unless the unit or circuit disconnect switch is open. Refer to the wiring diagram for further details.***

- ***For some units, a separate 220V power supply may exist, check the electrical wiring for more informations***
- ***In case of maintenance operations on fans (grills replacement ...) ensure that the power is shut off to avoid automatic restart.***
- ***Before the opening of the refrigerant circuit, check the pressure with manometers or pressure sensors.***
- ***Never leave a unit stopped with valves closed on the liquid line, refrigerant could be trapped and the pressure would rise.***

- All installation parts must be maintained by the personnel in charge, in order to avoid material deterioration and injuries to people. Faults and leaks must be repaired immediately. The authorized technician must have the responsibility to repair the fault immediately. Each time repairs have been carried out to the unit, the operation of the safety devices must be re-checked.
- *Follow guidance and recommendations given in safety and machine standards such as EN378, ISO5149, etc*
- *Do not use oxygen to purge lines or to pressurize a machine for any purpose. Oxygen gas reacts violently with oil, grease, and other common substances.*
- *Never exceed the specified maximum operating pressures. Verify the allowable maximum high- and low-side test pressures by checking the instructions in this manual and the pressures given on the unit name plate.*
- *Do not use air for leak testing. Use only refrigerant or dry nitrogen.*
- *Do not unweld or flame cut the refrigerant lines or any refrigerant circuit component until all refrigerant (liquid and vapour) has been removed from chiller. Traces of vapour should be displaced with dry air nitrogen. Refrigerant in contact with an open flame produces toxic gases.*
- *Do not siphon refrigerant*
- *Avoid spilling liquid refrigerant on skin or splashing it into the eyes. Use safety goggles. Wash any spills from the skin with soap and water. If liquid refrigerant enters the eyes, immediately and abundantly flush the eyes with water and consult a doctor.*

### **2.1.1 - Safety Definition**

The air cooled chillers meet the following safety definitions:

- Pr-EN-378-1.
- EU Directive 89/392/EG ("Machine Directive").
- EN-60204-1.
- "EMC Directive".
- Pressure Equipment Directive 97/23/CE.

And is provided with CE markings (on the condition that the necessary options are present) for further information see II-A declaration.

### **2.1.2 - Warning labels**

The chiller is marked with the following warning labels to alert to potential hazards (on or near the potentially hazardous part).

<b>High temperatures</b>	<b>Electrical voltage</b>	<b>Rotating parts</b>	<b>Sharp parts</b>

Check regularly that the warning labels are still in the correct positions on the machine and replace them if necessary.



## INSTALLATION - TRANSPORT - HANDLING

### 3. INSTALLATION

#### 3.1 - Transport - Handling

##### 3.1.1 - Controls and delivery checks

On receipt of new equipment please check the following points. It is the customer's responsibility to ensure that the products are in good working order (fill the check list page 36):

- The exterior has not been damaged in any way.
- The lifting and handling equipment are suitable for the equipment and comply with the specifications of the handling instructions enclosed here-in.
- Accessories ordered for on site installation have been delivered and are in good working order.
- If the unit is delivered with its operating charges of refrigerant, that there has been no leakage (use an electronic detector).
- The equipment supplied corresponds to the order and matches the delivery note.

If the product is damaged, exact details must be confirmed in writing by registered post to the shipping company within 48 hours of delivery (working days).

**A copy of the letter must be addressed to LENNOX and the supplier or distributor for information purposes.**

**Failure to comply will invalidate any claim against the shipping company.**

Please be reminded that LENNOX is not responsible for off-loading and positioning.

##### 3.1.1.1: Unit Nameplate

The rating plate provides a complete reference for the model and ensures that the unit corresponds to the model ordered. It states the electrical power consumption of the unit on start-up, its rated power and its supply voltage.

**The supply voltage must not deviate beyond +10/-10 %.**

The start-up power is the maximum value likely to be achieved for the specified operational voltage. The customer must have a suitable electrical supply. It is therefore important to check whether the supply voltage stated on the unit's rating plate is compatible with that of the mains electrical supply. The rating plate also states the year of manufacture as well as the type of refrigerant used and the required charge for each compressor circuit.

		Factory Mions					
		Z.I LES MEURIERES 69780 MIONS FRANCE					
		0062					
<b>Unit type:</b>		<b>NAH270DNM1M</b>					
<b>Serial NR:</b>		<b>138305/01</b>					
	<b>Voltage (V)</b>	<b>Phase (Ph)</b>	<b>Frequency (Hz)</b>	<b>Current (A)</b>			
<b>Elec supply</b>	400	3	50	<b>Nominal</b>	<b>Starting</b>		
<b>Elec auxiliary</b>	24	1	50	322	530		
		<b>Min</b>		<b>Max</b>			
		<b>Test</b>	<b>Service</b>	<b>Test</b>	<b>Service</b>		
<b>Pressure (bar)</b>		0	0	41	43		
<b>Temperature (°C)</b>		-20		50			
<b>Capacities (Kw)</b>		<b>Ref charge (Kg)</b>				<b>Dates</b>	
<b>Cooling</b>	<b>Heating</b>	<b>C1</b>	<b>C2</b>	<b>C3</b>	<b>C4</b>	<b>Prod.</b>	<b>Test</b>
271	312	43	43	0	0	2007	21/02/08
<b>Fluid</b>	<b>Fluid group</b>	<b>Energy class</b>		<b>Weight (Kg)</b>			
R410A	2	C		2990			
<b>This product is used for Air Conditioning</b>							

**Nota:** According to PED, Service Pressure is the maximum allowed pressure and so is equal to the relief valve setting. Test pressure corresponds to safety protection e.g. HP pressure switches setting. Then test pressure is lower than service pressure.

### **3.1.2 - Storage**

When units are delivered on site they are not always required immediately and are sometimes put into storage. In the event of medium to long-term storage, we recommend the following procedures:

- Ensure that there is no water in the hydraulic systems.
- Keep the heat exchanger covers in position.
- Keep protective plastic film in position.
- Ensure the electrical panels are closed.
- Keep all items and options supplied in a dry and clean place for future assembly before using the equipment.

**It is strongly recommended to store units in a dry, sheltered place (in particular for units that will be installed indoors).**

## **3.2 - LIFTING THE UNIT**

### **3.2.1 - Safety instructions**

Installation, start up and adjustment of this equipment can be dangerous if certain system specific factors are ignored, such as operating pressures, electrical components, locations (roofs, terraces and other structures located well above ground level).

Only highly qualified contractors and technicians with sound knowledge of this type of equipment, are authorised to install, start up and service it.

During any service operations, observe the recommendations given on labels or instructions sent with the equipment, as well as any other applicable safety procedures.

- Follow all safety rules and regulations
- Wear protective glasses and work gloves
- Handle heavy or bulky equipment carefully during lifting and moving operations, and when setting it on the ground.



**CAUTION: BEFORE EACH SERVICE OPERATION MAKE SURE THAT THE UNIT POWER SUPPLY IS PROPERLY ISOLATED AND LOCKED OUT.**

**NOTE: SOME UNITS MAY HAVE A SEPARATE 230V CONTROL SUPPLY THAT REQUIRES SEPARATE ISOLATION. PLEASE CHECK THE WIRING DIAGRAM.**

### **3.2.2 - Handling**

Handling operations must be carried out by qualified personnel. Comply strictly with lifting instruction pasted on the unit. Unit handling operations must be carried out carefully to avoid jolting the frame, the panels, the electrical box, the condenser coil fins, etc....

#### **NOTE:**

**The heat exchangers of the condensers could be protected from damage during transport by plastic plates. The machine is also wrapped in packing foil. It is recommended to leave this protection in place during any transport and lifting operations, and not to remove the plastic plates until commissioning (take care that the protecting foil wrapping is not blown away!).**

#### **NOTE:**

**Rubber anti-vibrations mountings (AVM) & factory accessories are to be found in the control panel for shipping. If the unit is mounted on anti-vibration mountings, these should be fitted to the unit before final positioning.**

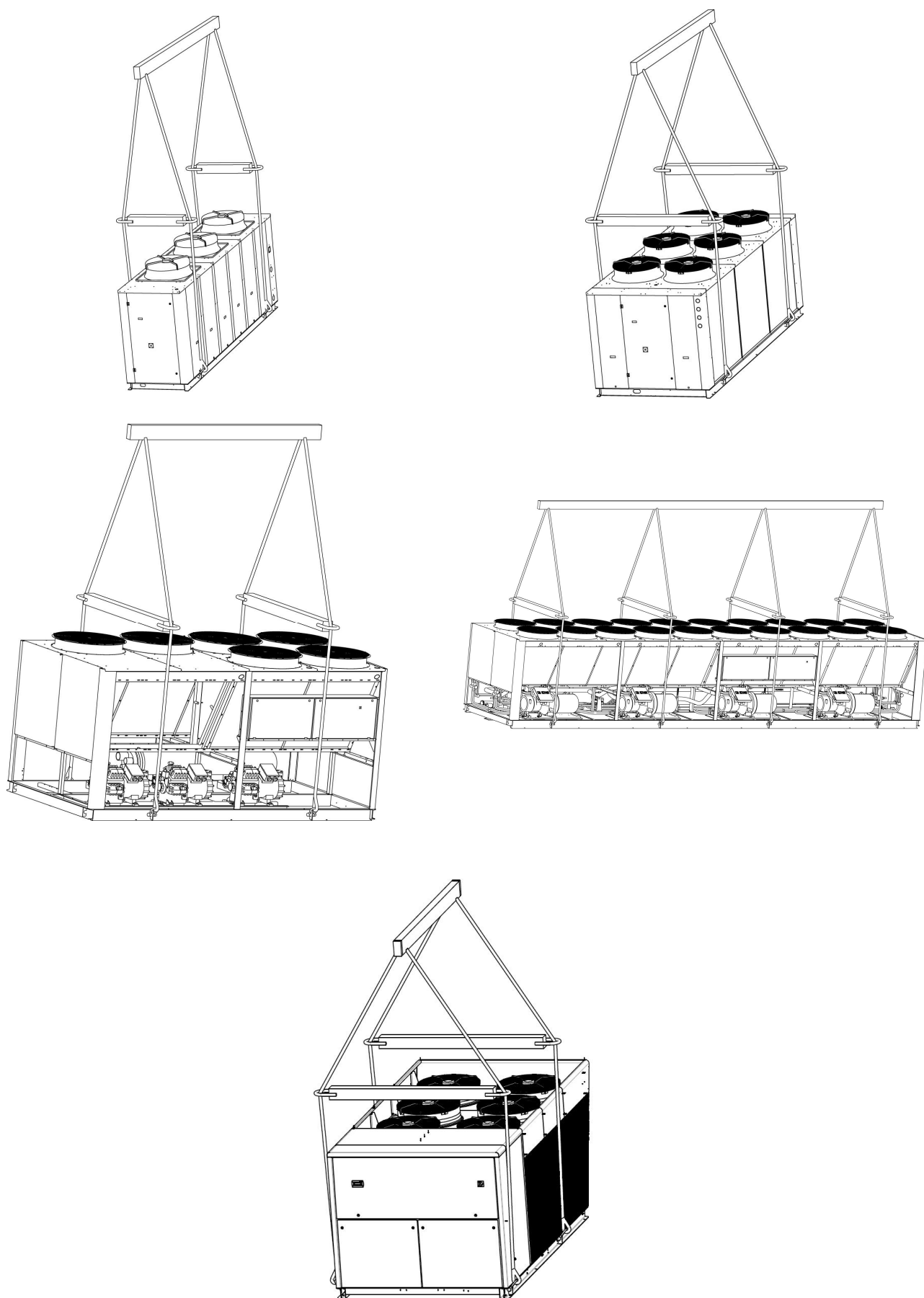

### 3.3 - LAY-OUT AND INSTALLATION REQUIREMENTS

The following preparations are important for the installation of the chiller:

- Air-cooled chillers with helicoids fans such as Ecologic or NEOSYS are designed for outdoor installation. Please consult Lennox prior to implementing other types of installation.
- Locate the chiller where it is least affected by wind (install windbreaks where wind speeds > 2.2 m/s).
- The ground beneath the unit must be flat, level and of sufficient strength to support the weight of the unit with its full liquid charge, and the occasional presence of the usual service equipment.

In locations exposed to frost, the supporting surface, if the unit is installed on the ground, must be built on concrete stakes extending downwards beyond the normal depth of frost. It is always advisable to build a supporting surface detached from the general building structure to avoid transmission of vibrations.

- On normal applications, unit rigidity and point load positions enable installation to minimise vibrations. Vibration isolators may be used by contractors on installations requiring particularly low vibration levels.



- **Use of vibration isolators MUST be accompanied by installation of flexible connections in the unit water piping. Vibration isolators must also be fixed to the unit BEFORE being fixed to the ground.**

**Selection of vibration absorbing isolator capacity is not Lennox's responsibility.**

The unit must be bolted to the vibration isolators and the latter solidly fixed into the concrete slab.

Check that vibration isolator contact surfaces fit flush to the floor. If necessary, use spacers or re-surface the flooring, but in all events, make sure that the isolators seat flatly on the supporting surface.

- It is essential that the units be installed with sufficient free space around them to enable proper circulation of air ejected by the condensers and to provide easy access to all unit components for servicing and maintenance. If the air rejected by the condenser encounters any obstacles, it will tend to be recycled by the fans. This will cause an increase in the temperature of the air used to cool the condensers. Obstruction of the air outlet will also impair air distribution across the entire heat exchanging surface of the condenser. Both of these conditions, which reduce the heat exchange capacity of the coils, will cause an increase in condensing pressure. This will lead to a loss of capacity and an increase in compressor power input.
- To prevent air flow to be reversed due to prevailing winds, units cannot be completely shrouded with a higher, uninterrupted wind shield. If such a configuration cannot be avoided, an air ejection duct must be installed at the same height as the surrounding shield.



***It is important that units must be levelled failure to install unit correctly will void warranty.***

#### CLEARANCES AROUND THE UNIT

For more details, please consult our Application Guides or the drawings supplied with the unit.

**NEOSYS range**

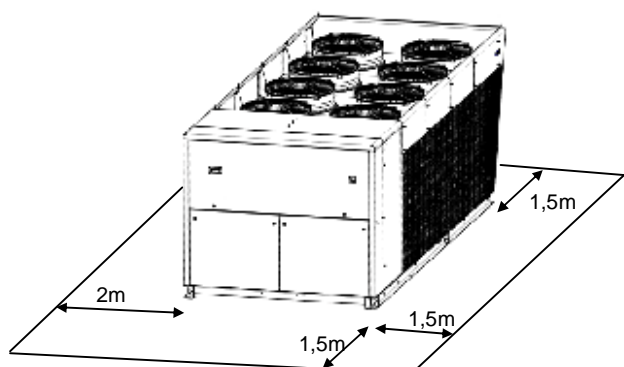

**Unit with screw compressor**

OVERHEAD OBSTRUCTIONS ARE NOT PERMITTED

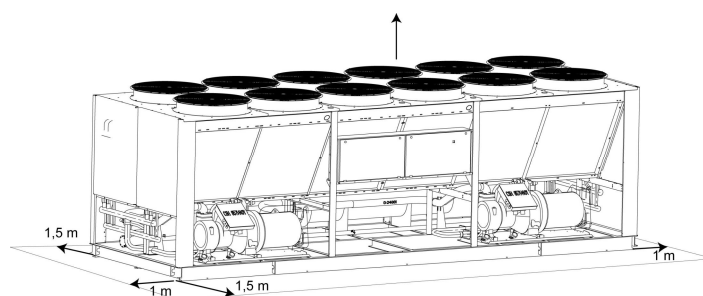

## ECOLOGIC range

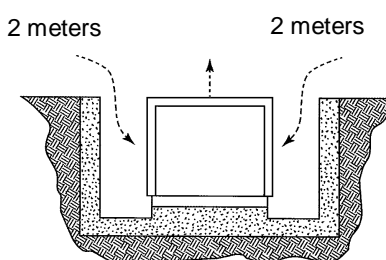
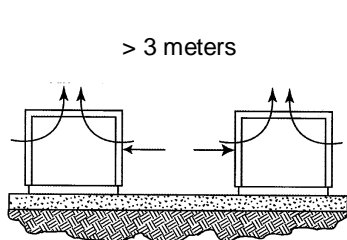
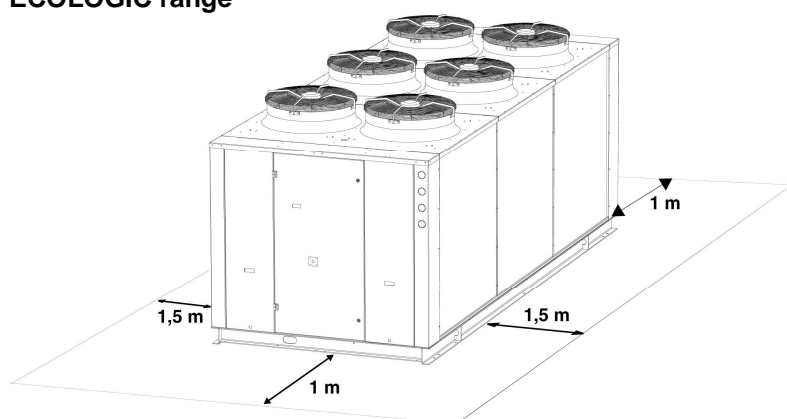

Not recommended

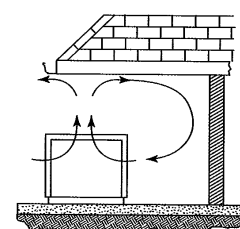

Not allowed



For any air cooled unit, it is necessary to have a minimum distance between air coil and any obstacle of 1,5 meters.

For any chiller a minimum distance of 1 meter is required for the good opening and servicing of the electrical box.

## 3.4 - WATER CONNECTIONS

### 3.4.1 - Water connections - Evaporator/Condenser

The water circulating pump will be preferably installed upstream so that the evaporator/condenser will be subjected to positive pressure. Entering and leaving water connections are indicated on the certified drawing sent with the unit or shown in the sales brochure.

The water pipes connected to the unit must not transmit any radial or axial force to the heat exchangers or any vibration.

It is important to follow non exhaustive recommendations hereunder:

- Comply with the water inlet and outlet connections shown on the unit.
- Install manual or automatic air purge valves at all high points in the circuit.
- Install a safety valve as well as an expansion tank to maintain the circuit pressure. This option may be included inside the unit.
- Install thermometers in both the entering and leaving water connections.
- Install drain connections at all low points to allow the whole circuit to be drained.
- Install stop valves, close to the entering and leaving water connections.
- Use flexible connections to reduce the transmission of vibrations.
- After testing for leaks, insulate all pipe work, to reduce thermal leaks and to prevent condensation.
- If the external water pipes are in an area, where the ambient temperature is likely to fall below 0°C, insulate the piping and add an electric heater. As an option, the internal unit piping is protected.
- Ensure full earthing continuity

For unit with shell and tube heat exchangers, a drainage plug is located at the base of the evaporator. A drainage pipe may be connected to this to enable drainage of evaporator water for service operations or for seasonal shut down.



The use of a water filter in the water circuit upstream of the heat exchanger is mandatory. This filter must remove all particles with a diameter greater than 1 mm, and must be positioned within 1 meter of the inlet of the exchanger. It may be supplied as an option by the manufacturer. This filter will prevent the plate heat exchanger from clogging.



**LACK OF FILTER AT THE INLET OF THE HEAT EXCHANGER WILL MAKE WARRANTY VOID.**

Hydraulic drawings in Annexes page 50 to 54, or supplied with the unit.



**CHARGING AND REMOVING HEAT EXCHANGE FLUIDS SHOULD BE DONE BY QUALIFIED TECHNICIANS WITH DEVICES THAT MUST BE INCLUDED ON THE WATER CIRCUIT BY THE INSTALLER. NEVER USE THE UNIT HEAT EXCHANGERS TO ADD HEAT EXCHANGE FLUID.**

**3.4.2 - Water analysis**

The water must be analysed; the water circuit installed must include all items necessary for treatment of the water: filters, additives, intermediate exchangers, bleed valves, vents, isolating valves etc... depending on the results of the water analysis.



**We do not advise operation of the units with open loops which can cause problems with oxygenation, or operation with untreated ground water.**

Use of untreated or improperly treated water can cause deposits of scale, algae and sludge or cause corrosion and erosion. It is advisable to call in a qualified water treatment specialist to determine what kind of treatment will be necessary. The manufacturer cannot accept liability for damage caused by the use of untreated or improperly treated water, salt water or brine.

Here are our non exhaustive recommendations given as an indication:

- No NH<sub>4</sub><sup>+</sup> ammonium ions in the water, they are very detrimental for copper. <10mg/l
- Cl<sup>-</sup> Chloride ions are detrimental for copper with a risk of perforations by corrosion by puncture. < 10 mg/l.
- SO<sub>4</sub><sup>2-</sup> sulphate ions can cause perforating corrosion.< 30 mg/l.
- No fluoride ions (<0.1 mg/l).
- No Fe<sub>2</sub><sup>+</sup> and Fe<sub>3</sub><sup>+</sup> ions with dissolved oxygen. Dissolved iron < 5 mg/l with dissolved oxygen < 5 mg/l. Over those values, it means a corrosion of steel which may generate a corrosion of copper parts under deposit of Fe – this is mainly the case with shell and tube heat exchangers.
- Dissolved silicon: silicon is an acid element of water and can also lead to corrosion risks. Content < 1mg/l.
- Water hardness: TH >2.8 K. Values between 10 and 25 can be recommended. This will facilitate scale deposit that can limit corrosion of copper. TH values that are too high can cause piping blockage over time.
- TAC< 100.
- Dissolved oxygen: Any sudden change in water oxygenation conditions must be avoided. It is as detrimental to deoxygenate the water by mixing it with inert gas as it is to over-oxygenate it by mixing it with pure oxygen. The disturbance of the oxygenation conditions encourages destabilisation of copper hydroxides and enlargement of particles.
- Specific resistance – electric conductivity: the higher the specific resistance, the slower the corrosion tendency. Values above 3000 Ohm/cm are desirable. A neutral environment favours maximum specific resistance values. For electric conductivity values in the order of 200-6000 S/cm can be recommended.
- pH: pH neutral at 20°C (7 < pH < 8)

**3.4.3 - Antifreeze protection**

**3.4.3.1: Use glycol/water solution**

**ADDITION OF GLYCOL IS THE ONLY EFFICIENT WAY TO PROTECT AGAINST FREEZING**



The glycol/water solution must be sufficiently concentrated to ensure proper protection and prevent formation of ice at the lowest outdoor air temperatures expected on an installation. Take precautions when using non passivated MEG antifreeze solutions (Mono Ethylene Glycol or MPG Mono Propylene Glycol). Corrosion can occur with these antifreeze solutions with oxygen.

**3.4.3.2: Drain the installation**



To enable drainage of the circuit, make sure that drain cocks are installed at all the low points of the circuit.

To drain the circuit, the drain cocks must be opened and an air inlet ensured.

Note : air bleeders are not designed to admit air.

**FREEZING OF AN EVAPORATOR DUE TO COLD WEATHER CONDITIONS IS NOT COVERED BY LENNOX WARRANTY.**

**3.4.4 - Electrolytic corrosion**



We would like to draw your attention to the problems of corrosion due to electrolytic corrosion caused by an imbalance between earthing points.

**AN EVAPORATOR THAT IS PUNCTURED BY ELECTROLYTIC CORROSION IS NOT COVERED BY THE UNIT WARRANTY**

**3.4.5 - Minimum water content**

The minimum volume of the chilled water circuit must be calculated with the formulas here under. If necessary, install a buffer tank. Proper operation of regulating and safety devices can only be ensured if the volume of water is sufficient.

The theoretical volume of the water loop for a proper air conditioning operation can be calculated using the formulas hereafter:

**NEOSYS RANGE**

- Vt → Minimum water content of the installation
- Q → Chiller cooling capacity in kW
- N → Number of control steps available in the unit
- Dt → maximum acceptable temperature rise (Dt = 6°C for an air conditioning application)

$$V_{\text{mini}} = 86 \times Q / (N \times Dt)$$

**NAC**

**NAH**

Unit Size	Number of stages	Mini Water volume (L)
200	6	478
230	6	549
270	6	645
300	5	860
340	6	812
380	5	1089
420	7	860
480	6	1147

Unit Size	Number of stages	Mini Water volume (L)
200	6	478
230	6	549
270	6	645
300	4	1075

**OTHER RANGES**

- Vt → Minimum water content of the installation
- Q → Cooling capacity of the chiller in kW
- N → Number of Compressor
- X → Number depending of the type of compressor (ecologic scroll 12, screw units 8, Recip 10)

$$V_t = 172 \times Q / (n \times X) \text{ litres}$$

Example, for a screw chiller with 2 compressors 400kW, water conditions, the minimum volume is :

$$V_t = 172 \times 400 / (2 \times 8) = 4300 \text{ l.}$$

This formula will give the minimum water capacity of the installation that will ensure a temperature rise of the water loop of 5°C during anti short cycle of compressors.



**These formulas are only applicable for air-conditioning installation and must not be used for process cooling where particular temperature stability is required.**

T

**3.4.6 – Neosys range with hydraulic module - maximum water content**

The maximum water content of the installation is determined by the capacity of the expansion vessel.  
On units fitted with a standard Hydraulic Module it is possible to determine the maximum water content of the installation.

NEOSYS Unit Size	Expansion Vessel Volume	Pressure in the exp Vessel	Max volume clear water (L)		Max volume Glycol water (L)	
			Static pressure 5m	Static pressure 10m	Static pressure 5m	Static pressure 10m
200 230 270 300	50 L	1,5 bar	5230 L	4180 L	4020 L	3210 L
340 380 420 480	80 L	2 bar	8370 L	6690 L	6430 L	5150 L

**3.4.6 - Flow switch**

A flow switch must be installed on the evaporator water inlet or outlet, so as to enable detection of water flow through the heat exchanger before the unit is started up. This will protect the compressors against any eventual liquid slugging during the starting phase and prevent accidental ice formation in the evaporator, if the flow of water is interrupted.

Flow switches is available as standard on NEOSYS and as an option on other chiller ranges.

When flow switch is not installed in the unit the normally open contact of the site flow switch should be connected to the terminals provided to that effect in the unit electrical box. (See the wiring diagram supplied with the unit).

The normally closed contact can be used as an indication of a lack of flow condition.

**Warranty is void if a flow detection device is not fitted and connected to the LENNOX control panel.**



**ELECTRONIC FLOW SWITCH**

NEOSYS units are fitted with an electronic flow switch as standard. This flow switch is made of stainless steel and has no moving parts. It detects flow in the water loops by measuring the temperature difference between the heated tip and the base of the probe. It is therefore absolutely mandatory to ensure that the base of the measuring element is correctly placed in the water flow.

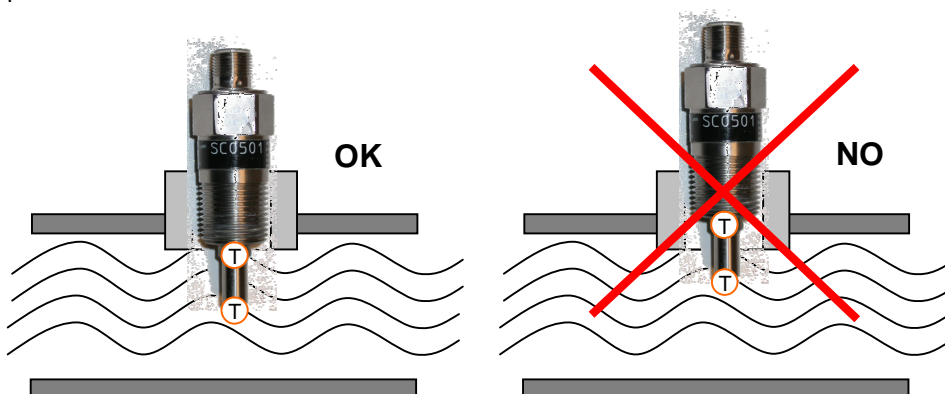



### 3.5 - ELECTRICAL CONNECTIONS

First of all, make sure that power supplies from the building to the place where the unit is installed are properly established and that wire gauges are in keeping with the start up and running currents.

Check tightness of all electrical connections.

You **MUST** make absolutely certain that the power supplies applied to the power and control circuits are those for which the electrical panel was manufactured.

A main isolator switch must be inserted between the end of the power supply cable and the unit to enable total isolation of the latter when necessary. Chillers are supplied as standard without a main isolator switch. This is available as an option.

#### WARNING



**Wiring must conform to applicable regulations. The type and location of fused isolators must also conform to regulations. For the sake of safety, install them where they can be seen and in easy reach of the unit. Units must have full earthing continuity.**

#### IMPORTANT



**Operation of a unit with the wrong power supply or with excessive phase imbalance constitutes abuse and is not covered by the LENNOX warranty. If phase imbalance exceeds 2 % for voltage and 1 % for current, contact your local electricity company immediately before powering up the unit.**

**Be also careful with power factor correction. Central excessive correction (>0.95) may generate transitory phenomena which could damage motors and contactors during starts and stops. Check the instantaneous voltage during those sequences. In case of doubt, contact Lennox technical support for any power factor correction.**

### 3.6 - SOUND LEVELS

Liquid chillers are a significant source of noise in refrigeration and air conditioning systems.

Account is taken of technical constraints, both in design and manufacturing, sound levels cannot be improved much further than specified.

Sound levels must therefore be accepted for what they are, and the area surrounding the chillers should be treated as necessary. The quality of installation can either improve or decrease initial sound characteristics: it may be necessary to provide further treatment such as sound-proofing or installation of screens around units installed externally. The choice of the location for the installation can be of great importance: reflection, absorption, transmission of vibrations.

The type of unit support is also very important: inertia of the room and the structure of the walling, interfere with the installation and its behaviour.

Before taking any other steps, first determine whether the sound level is compatible or not with the environment, what it is perfectly justifiable and that these measures envisaged will not cause unreasonable cost.

Determine what level of sound proofing is necessary on the equipment, the installation (silencer, vibration isolators, and screens) and on the building (reinforcement of flooring, false ceilings, and wall coverings).

It may be necessary to contact an engineering office that specialises in sound abatement.

### **3.7 - CONNECTION OF SPLIT UNITS**

Connections between the unit and the condenser or the evaporator must be made by a qualified refrigeration engineer and require several important precautions.

In particular, the shape and dimensions of the gas lines must be carefully designed to ensure proper oil return in all cases and prevent liquid from returning into the cylinder heads when the compressor is stopped.

On units fitted with capacity reducers, the piping sizes must be calculated so that gas velocity is sufficiently high when the unit is operating on capacity reduction.

Non application of these precautions will cancel the compressor warranty.

We recommend following ASHRAE recommendations.

#### **3.7.1 - Liquid line sizing**

Determine the size of liquid lines using:

- 1) Operating conditions at full load.
- 2) Maximum pressure drop of 100 kPa
- 3) Liquid velocity under 2 m/s (to avoid liquid slugging).
- 4) For liquid risers, make sure that liquid sub cooling is sufficient to counteract the loss of static pressure and prevent gas flashing.

#### **3.7.2 - Discharge lines and suction lines**

Calculate these to obtain a gas velocity in vertical sections that enables compressor oil migration and steady return to the compressor (tables C and D - page 20).

Determine the dimensions of vertical lines using the following tables.

Horizontal lines may be bigger in order to compensate pressure drop in vertical lines.

The total pressure drop in the piping has to be lower or equal to 1°C at saturation pressure on the suction side.

## UNITS WITH REMOTE CONDENSER

Unit with remote condenser  
without capacity control

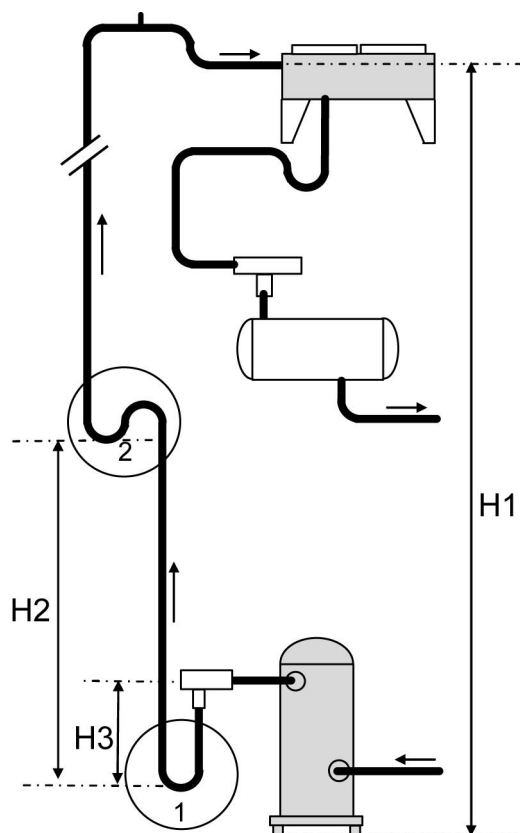

Unit with remote condenser  
with capacity control

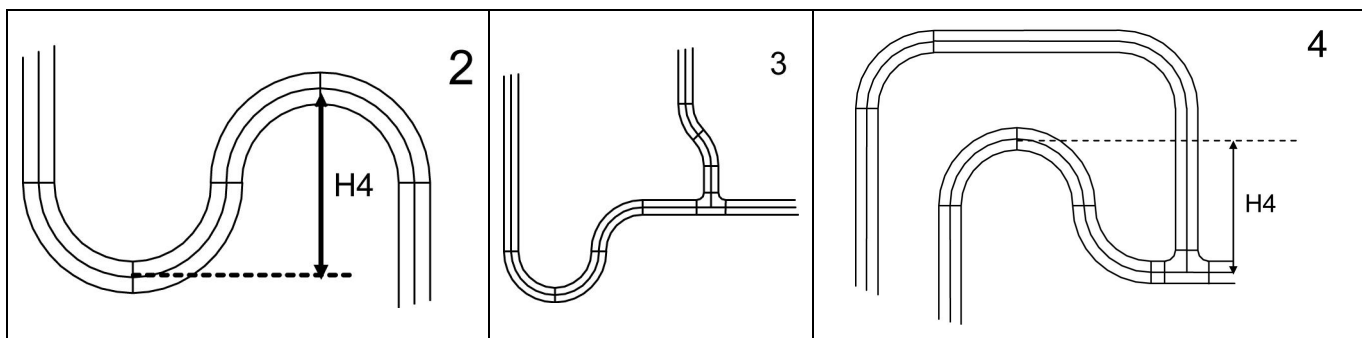
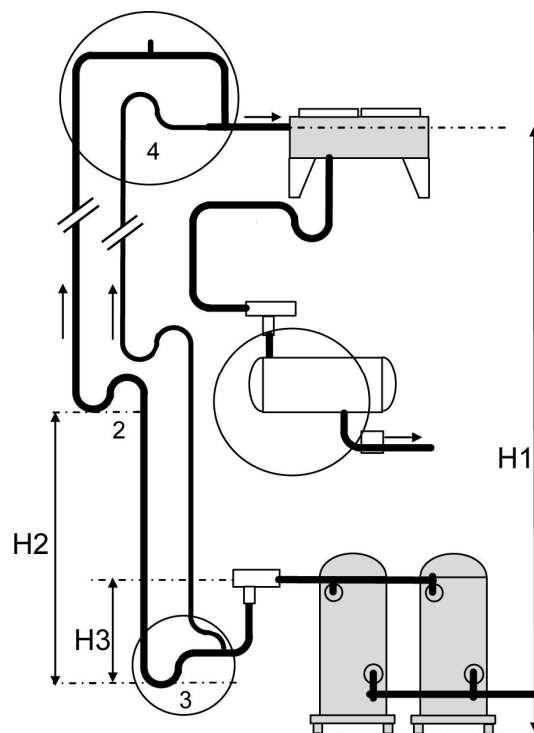

H1 : 15 m. maxi  
H2 : 5 m. maxi  
H3 : 0,3 m. maxi  
H4 : 0,15 m. maxi

1 - Lower trap with single tube  
2 - Clode coupled trap  
3 - Lower trap with double tubes  
4 - Higher trap with double tubes

**WARNING:** The liquid level between the condenser and the check valve A must compensate the check valve pressure drop

***If receiver option: PED declaration class 3***  
***If no receiver option: PED declaration class 1***

### CONDENSING UNITS

Condensing unit without capacity control

Min 0,25%

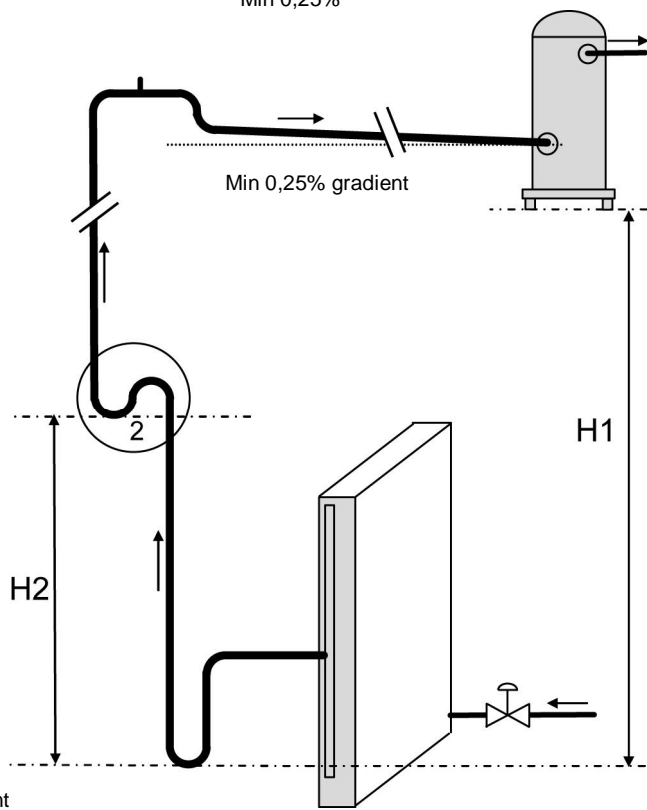

Condensing unit with capacity control

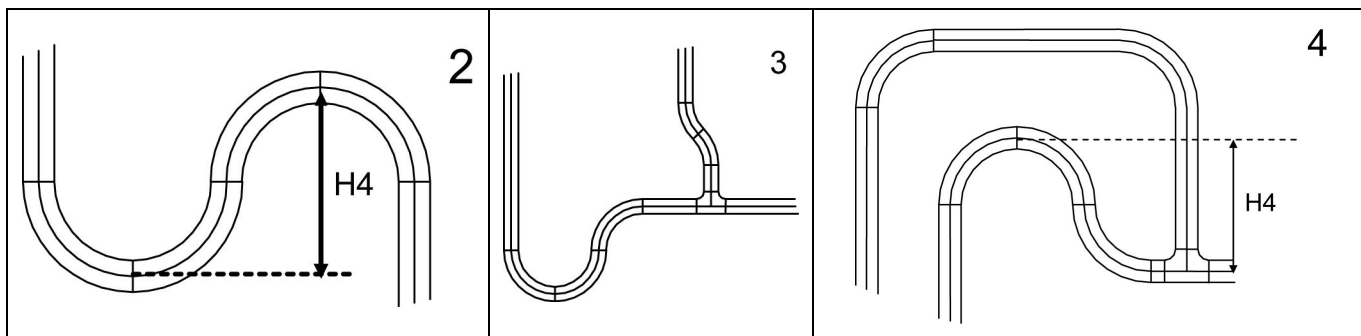
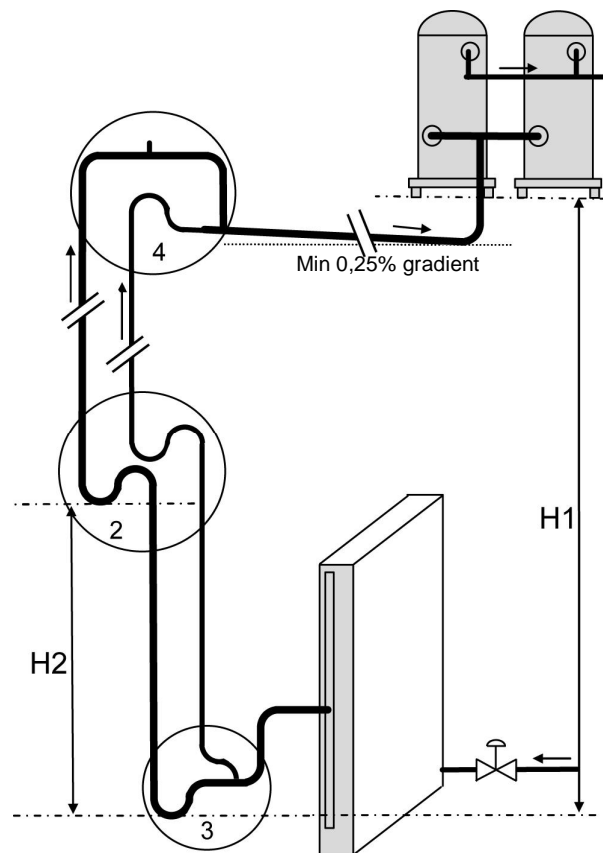

<p><b>H1</b> : 15 m. maxi  <b>H2</b> : 5 m. maxi  <b>H4</b> : 0,15 m. maxi</p>	<p>1 - Lower trap with single tube                  2 - Clode coupled trap                  3 - Lower trap with double tubes                  4 - Higher trap with double tubes</p>
--	---

***If receiver option: PED declaration class 3***  
***If no receiver option: PED declaration class 1***

**Minimum refrigeration capacity in kW for oil entrainments up Suction risers  
Refrigerant: R407C**

Table C		Tubing nominal OD, mm											
Saturated temperature (°C)	Suction gas temperature (°C)	12	15	18	22	28	35	42	54	67	79	105	130
-5	0	0,39	0,71	1,20	2,04	3,88	6,88	11,11	21,31	36,85	55,86	115,24	199,30
	10	0,37	0,68	1,14	1,94	3,68	6,53	10,54	20,20	34,94	52,95	109,25	189,14
5	10	0,47	0,86	1,45	2,47	4,69	8,33	13,44	25,77	44,58	67,56	139,39	241,30
	20	0,44	0,81	1,36	2,31	4,39	7,79	12,58	24,13	41,73	63,25	130,49	225,90

**Minimum refrigeration capacity in kW for oil entrainments up HOT-Gas risers  
Refrigerant: R407C**

Table D		Tubing nominal OD, mm											
Saturated temperature (°C)	Suction gas temperature (°C)	12	15	18	22	28	35	42	54	67	79	105	130
30	70	0,60	1,09	1,84	3,13	5,95	10,55	17,03	32,65	56,47	85,59	176,59	305,70
	80	0,58	1,06	1,79	3,04	5,78	10,25	16,55	31,74	54,90	83,21	171,67	297,19
	90	0,57	1,04	1,74	2,96	5,64	10,00	16,14	30,95	53,53	81,13	167,39	289,77
40	80	0,62	1,13	1,90	3,24	6,16	10,93	17,65	33,85	58,55	88,73	183,07	316,92
	90	0,60	1,10	1,85	3,16	6,00	10,65	17,19	32,96	47,01	86,40	178,26	308,60
	100	0,58	1,07	1,80	3,07	5,83	10,34	16,70	32,02	55,38	83,94	173,17	299,79
50	90	0,63	1,16	1,94	3,31	6,29	11,16	18,02	34,55	59,77	90,58	186,88	323,52
	100	0,61	1,12	1,88	3,21	6,10	10,82	17,47	33,50	57,95	87,83	181,21	313,70
	110	0,60	1,09	1,83	3,13	5,94	10,54	17,02	32,63	56,44	85,53	176,47	305,49

**3.7.3 - Mechanical isolation of refrigerant lines**

Isolate refrigerant lines from the building to prevent the vibrations normally generated by the lines to the building structure. Avoid bypassing the isolation system on the unit by fixing refrigerant lines or electrical conduits too tightly. Any vibrations will be transmitted to the building by rigid piping.

Lack of vibration isolation on refrigerant pipework will lead to early failure of copper pipe and loss of gas.

**3.7.4 - Pressure test**

To avoid formation of copper oxide during brazing operations, blow a little dry nitrogen through the pipes. Piping must be made with tubing that is perfectly clean, plugged during storage and between connections operations. During these operations, observe the following precautions:

- 1) Do not work in a confined atmosphere, refrigerant fluid can cause asphyxiation. Make sure there is sufficient ventilation.
- 2) Do not use oxygen or acetylene instead of refrigerant fluid and nitrogen for leak testing: this could cause a violent explosion.
- 3) Always use a regulator valve, isolating valves and a pressure gauge to control test pressure in the system. Excessive pressure can cause lines to burst damage to the unit and/or cause an explosion with severe personal injury.

Ensure conduct liquid line and gas line pressure tests are in conformity with applicable legislation. Before starting up a unit on a receiver, the piping and the condenser must be dehydrated. Dehydration should be carried out using a double stage vacuum pump, capable of drawing 600Pa absolute pressure vacuum.

Best results are obtained with a vacuum down to 100 Pa. To get down to this level at normal temperatures, i.e. 15 °C, it is often necessary to leave the pump running for 10 to 20 hours. The duration of pump operation is not a factor of efficiency. The pressure level must be checked before the unit is put into service.

### **3.7.5 - Refrigerant charge**

Chillers with R407C and R410A must be filled in the liquid phase. Never charge a machine operating on R407C or R410A in the vapour phase (vapour): the composition of the mixture could be modified.

In liquid phase, connect either to a liquid isolating valve, or to the quick-connector on the liquid line at the valve outlet. For unit using R22, the charging may be done in vapour phase in that case; connection will be made to the suction valve.

Note:

Splits units are supplied with a refrigerant or nitrogen holding charge. Before pulling down the vacuum for dehydration, completely purge the unit.

Charge the unit until there is a constant flow of bubble-free liquid in the sight-glass indicating that there is sufficient charge and controlled that sub cooling is correct according to the system design value.

In all cases, do not top up the charge until the unit reaches a stable state of operation.

It is pointless to overcharge a system, this can adversely affect operation.

Overcharging causes:

- Excessive discharge pressure,
- A risk of damage to the compressor,
- Excessive power consumption.

### **3.7.6 - Oil charge**

All units are delivered with a complete oil charge. In the case of split units, it may be necessary, due to the length of piping installed, to add a certain amount of oil compatible with the type of compressor and refrigerant used.

Please refer to the following oil table.

**Note: This table is valid for self-contained chillers only (or chillers mounted on receivers) on which the leaving water temperature is not lower than -5°C. For other cases, consult the documentation shipped with the machine.**

<b>Oil recommendation for Lennox chillers</b>			
<b>Refrigerant</b>	<b>Compressor type</b>	<b>Brand</b>	<b>Oil type</b>
R22	Screw CSH...	Bitzer	B320SH
R22	Scroll SM...	Maneurop	Maneurop 160 P
R22	Scroll ZR...	Copeland	Suniso 3 GS
R22	Reciprocating D8...	Copeland	Suniso 160P
R22	Reciprocating MT...	Maneurop	Maneurop 160 P
R407C	Screw CSH...	Bitzer	BSE170
R407C	Scroll SZ...	Maneurop	Maneurop 160 SZ
R407C	Scroll ZR...	Copeland	Copeland 3MA, Mobil EAL, Arctic 22CC, ICI Emkarate, RL32CF
R407C	Reciprocating D8...	Copeland	Mobil EAL Arctic 22
R407C	Reciprocating MS...	Maneurop	Maneurop 160 SZ
R410A	Scroll ZP ...	Copeland	ICI EMKARATE RL32-3MAF or for refill MOBIL EAL Arctic 22CC

### **3.7.7 - Air cooled condensers**

An air cooled condenser connected to a unit must have the same number of circuits as the unit. Selection of the condenser must be made carefully to enable transfer of the heat capacity of the unit even at the highest temperatures expected on an installation.

It is mandatory to control the head pressure in order to enable the unit to operate properly whatever the season:

A variety of different systems may be used, but the most simple and efficient of these modulates fan operation using a pressure or temperature control.

For condensers fitted with a small number of fans (1 or 2), it may be necessary to vary the fans speed.

Head pressure control systems that operate by flooding the condenser with liquid refrigerant should be avoided since they entail very large refrigerant charges and can cause serious problems if they are not correctly controlled.

## **3.8 - DUCTED UNITS INSTALLATION**

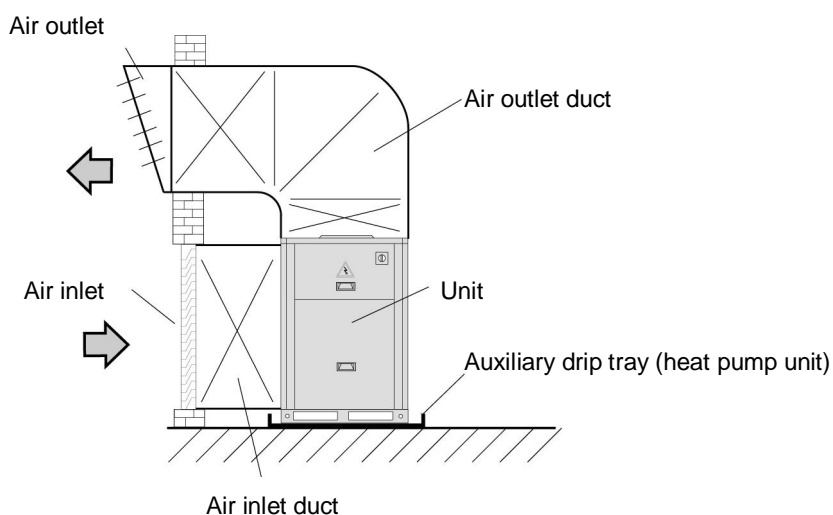

#### Notes:

- Be careful of air cycling between inlet and outlet.
- For air outlet it is recommended to duct each fan separately.

## PRELIMINARY CHECKS

### 4 - PRELIMINARY CHECKS

Check that all drain and purge plugs are in place and well tightened prior to fill the installation with water.

#### 4.1 - LIMITS

Prior to any operation, please check the operation limits of the unit given in the «ANNEXES» at the end of the IOM,

These tables will give you all necessary information concerning the operating envelope of the unit.

Please consult the «Risk analysis and hazardous situations according to 97/123 directive» given in the «ANNEXES» at the end of the IOM, or supplied with the unit.

#### 4.2 - REFRIGERATION CIRCUIT CHECKS AND RECOMMENDATIONS

In case of split units, check the installation has been made according to the recommendation described § Installation. The unit refrigeration circuit sketch is given in the «ANNEXES» at the end of the IOM, or supplied with the unit.

#### 4.3 - HYDRAULIC SYSTEM INSTALLATION CHECKS

The unit hydraulic sketch is given in the «ANNEXES» at the end of the IOM -.

#### 4.4 - INSTALLATION OF EXTERNAL HYDRAULIC COMPONENTS (supplied loose by Lennox).

Some hydraulic components may be supplied loose by Lennox:

- Filters
- Expansion vessels
- Valves
- Manometers
- ...



**The components are located inside the units and must be installed by a qualified engineer.**

**Note: In case of plate heat exchangers it is mandatory that a filter is installed at exchanger unit entrance. These filters must remove all particles with a diameter greater than 1 mm.**



## 4.5 - CHECK LIST BEFORE START-UP

Before proceeding with start up, even for a test of short duration, check the following points, after having made sure that all the valves on the refrigeration circuit are fully open (discharge valves and liquid valves). Starting up a compressor with the discharge valve closed will either trip the HP safety switch, or blow the cylinder head gasket or the internal pressure safety disc.

- 1) The liquid pump(s) and other apparatus interlocked with the unit (coils, air handling units, dry coolers, cooling towers, terminals such as fan coil units, etc.) are in working order as required by the installation and according to their own specific requirements.

**Place all water valves and refrigerant valves in their operating positions and start the water circulating pumps.**

**Ensure main power supply is isolated before any work is started. Ensure unit is correctly earthed and that earth continuity is correctly done.**

**Check that anti-vibration mountings are correctly installed and set.**

- 2) **Check the cleanliness and the tightness of all electrical connections**, both the connections made at the factory and the connections made on site. Also make sure that all thermostat bulbs are correctly inserted and tightened in the various wells, if necessary add heat conducting paste to improve contact. Make sure all sensors are correctly fitted and that all capillary tubes are fastened.

The technical data printed at the top of the wiring diagram should correspond with those indicated on the unit nameplate.

- 3) Make sure that the power supplied to the unit corresponds to its operating voltage and that **phase rotation corresponds to the direction of rotation of the compressors** (screw & scroll).
- 4) Make sure that the water circuits mentioned in 1 are completely filled with water or brine as the case may be; with the air bled out of all high points, including the evaporator ensuring they are perfectly clean and leaktight. In the case of machines with water cooled condensers, the condenser water circuit must be ready to operate, filled with water, pressure tested, bled, filter cleaned after 2 hours of operation of the water pump. Cooling tower in operating condition, water supply and overflow checked, fan in operating condition.
- 5) Reset all manually resetting safety devices (where necessary).  
Open power circuits to all components: compressors, fans....
- 6) Power up the unit with the main disconnect switch (option). Visually check the oil level in the compressor crankcases (bullseyes). This level may vary from one compressor to another, but should never be higher than the first third of the way up the bullseyes.



**CAUTION:** Power up the compressor crankcase heaters at least 24 hours before starting the unit. This will enable the refrigerant in the crankcases to evaporate off, and prevents damage to compressors through lack of lubrication during start up.

- 7) Start the pump(s) check the flow of liquid to be cooled through the heat exchangers: note the inlet and outlet water pressures, and, using the pressure drop curves, calculate liquid flow by applying the following formula:

**Actual flow**

$$Q = Q1 \times \sqrt{P2/P1}$$

Where

P2 = pressure drop measured on site

P1 = pressure drop published by LENNOX for a liquid flow of Q1

Q1 = nominal flow

Q = real flow

- 8) On units with air cooled condensers, check for correct operation of the fans and that the protective grilles are in good condition. Make sure that rotation is in the right direction.

9) On units with ducted fan, check the air flow and duct pressure drop.

On delivery, the drive belts are new and correctly tensioned. After the first 50 operating hours check and adjust the tension. 80% of the total elongation of belts is generally produced during the first 15 hours of operation.

Before adjusting the tension, make sure that the pulleys are correctly aligned.

To tension the belt, set the height of motor support plate by moving the plate adjustment screws.

The recommended deflection is 16 mm per metre from centre to centre.

Check that according to the diagram below (figure 14), the following ratio remains the same.

$$\frac{A(mm)}{P(mm)} = 20$$

The belts should always be replaced when :

- The disk is set to maximum,
- The belt rubber is worn or the wire is visible.

Replacement belts must have the same rated size as the ones they are replacing. If a transmission system has several belts, they must all be from the same manufacturing batch (compare serial numbers).

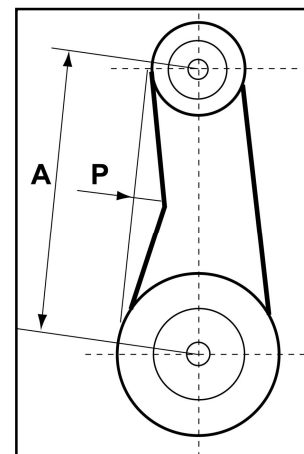

NOTE:



**Under-tensioned belt will slip, heat and wear prematurely. On the other hand, if a belt is over-tensioned, the pressure on the bearings will cause them to over-heat and wear prematurely. Incorrect alignment will also cause the belts to wear prematurely.**

9a) PULLEYS ALIGNMENT

After adjusting one or both of the pulleys, check the transmission alignment using a ruler placed on the inner face of the two pulleys.

**NOTE: The warranty may be affected if any major modification is made to the transmission without obtaining our agreement beforehand.**

The actual resistance of ductwork systems is not always identical to the calculated theoretical values. To rectify this, it may be necessary to modify the pulley and belt setting. To this effect, the motors are fitted with variable pulleys.

9b) AIRFLOW BALANCING

Measure the absorbed amps

If the absorbed amps are greater than the rated values, the ventilation system has a lower pressure drop than anticipated. Reduce the flow by reducing the rpm. If the system resistance is significantly lower than design, there is a risk that the motor will overheat resulting in an emergency cut out.

If the absorbed amps are lower than the rated values, your system has a higher pressure drop than anticipated. Increase the flow by increasing the rpm. At the same time you will increase the absorbed power which may result in having to increase the motor size.

9c) CHECKING AIRFLOW AND ESP

Using the following fan curve, the airflow, the total pressure available ( $P^{TOT}$ ) and the corresponding dynamic pressure ( $P_d$ ) can be estimated, for a specific operating point.

10) Before making any electrical connections, check that insulation resistance between power supply connection terminals is in keeping with applicable regulations. Check the insulation of all electrical motors using a DC 500V megohmmeter, following the manufacturer's instructions.

CAUTION: Do not start any motor whose insulation resistance is lower than 2 mégaohms.

Never start any motor while the system is under a vacuum.

### AT 18-18 FAN CURVE

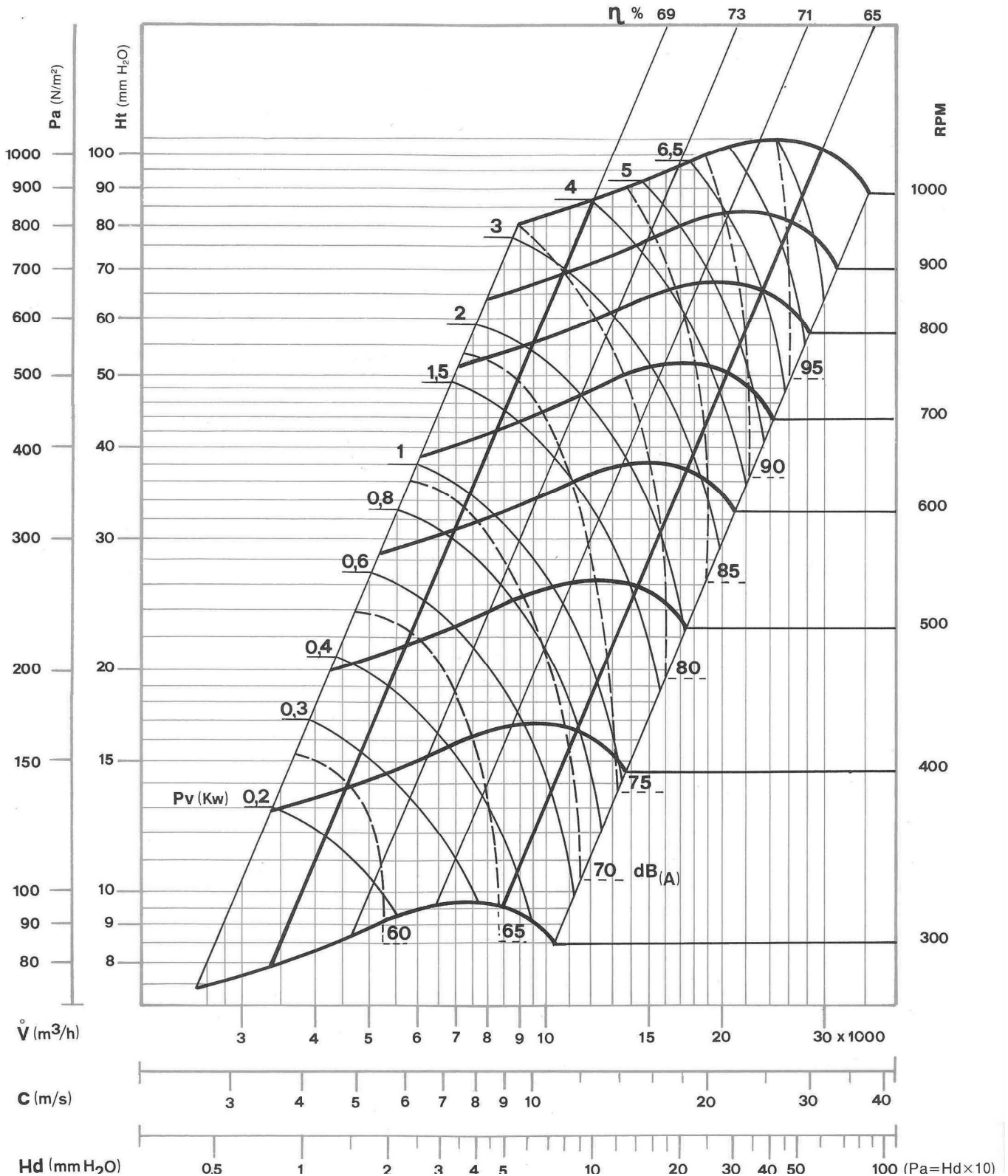

## UNIT START-UP

# 5 - UNIT START-UP

### 5.1 - CHECKS TO BE MADE DURING START UP

#### 5.1.1 CHECKS TO BE MADE DURING START UP

Before starting the unit, fill in the check list sheet §8.3 of this manual and follow the instructions below to be sure that the unit is correctly installed and ready to operate.

- 1) Thermometers and pressure switches installed in the chilled water circuit and the condenser water circuit.  
Check these safety devices in this order: high pressure switch, differential oil pressure switch, low pressure switch, fan control pressure switches and thermostats, anti short cycle relay. Make sure all indicator lights operate correctly.
- 2) Run evaporator pump prior to start the chiller.
- 3) Flow switch installed and wired into the control box operates properly.
- 4) With the compressor running, check the oil pressure. If there is a fault, do not restart the compressor again until the source of the problem has been located.
- 5) Check that there is sufficient cooling load on the day the start up is conducted (at least 50 % of the nominal load).

#### PROCEDURE TO FOLLOW WHEN STARTING THE UNIT

- 5-a) Press the power "ON-OFF" switch. The compressor will only start if the evaporating pressure is greater than the cut-in set point of the low pressure switch.  
Check immediately the good rotation of the compressor.  
Evaporating pressure drops steadily, the evaporator empties itself of the liquid refrigerant accumulated in it during storage. After a few seconds, the solenoid valve opens if any.
- 5-b) Check on the sight glass (upstream of the expansion valve) that the bubbles disappear progressively, indicating a correct refrigerant charge and without non condensable gas. If the humidity indicator changes colour, indicating the presence of humidity, replace the filter-drier cartridge if the latter is of the replaceable type. Checking the sub cooling after the condenser is recommended.
- 5-c) Check that, when the cooling load has been balanced by the capacity of the unit, the chilled liquid is at design temperature.
- 6) Check the current values per phase on each compressor motor.
- 7) Check the current values per phase on each fan motor.
- 8) Check compressor discharge temperature.
- 9) Check compressor oil pump temperatures (semi-hermetic reciprocating compressors).

- 10) Check suction and discharge pressures and compressor suction and discharge temperatures.
- 11) Check chilled liquid entering and leaving temperatures.
- 12) Check outdoor air temperature.
- 13) Check liquid refrigerant temperature at the condenser outlet.

These verifications should be made as quickly as possible with a stable cooling load, i.e. the cooling load of the installation should be the same as the capacity developed by the unit. Measurements taken without heeding this condition will result in unusable and probably wrong values.

These verifications can only be made once the proper operation of all safety devices and unit controls has been established.

## 5.2 - OIL CHARGE

Units have a complete operating charge of oil when they are shipped, and there is no need to add any oil before start up or afterwards. Note that unit shutdowns by the differential oil pressure switch are usually caused by other problems than a lack of oil in the refrigeration circuits. Overcharging with oil can cause serious problems on an installation, particularly for the compressors. The only time any oil might need adding is when a compressor is replaced.

## 5.3 - REFRIGERANT CHARGE

Self-contained units have a complete refrigerant charge at the time they are shipped. This charge may need to be topped up when the unit is installed or at other times during the service life of the unit. Additional charge can be introduced through the Schrader valves to appropriate positions. Every time fluid is added, check the state of the charge with the sight glass if available and also by the amount of liquid sub cooling at the condenser outlet.

Please refer to F Gas recommendations on refrigerant handling on page 04 and 88

### IMPORTANT



- **Start up and commissioning must be conducted by LENNOX authorised engineer.**
- **Never shut of power to the crankcase heaters except for lengthy service operations or seasonal shutdown.**

***Remember to power up the crankcase heaters at least 24 hours before the unit is restarted.***

## OPERATION

# 6 - OPERATION

## 6.1 - CLIMATIC CONTROL

cf. See the specific CLIMATIC 50 manual

cf. See the specific «Basic CLIMATIC controller» manual

## 6.2 - UNIT OPERATION

### 6.2.1 - Functions of refrigeration circuit components

#### **6.2.1.1 - Thermostatic expansion valve:**

##### **Very important:**

The thermostatic expansion valve fitted on each machine has been selected for a given operating range; it must be replaced with a model with the same reference from the same manufacturer.

#### **6.2.1.2 - Filter-drier:**

This is designed to remove all traces of humidity from within the refrigeration circuit, since this can impair operation of the unit, by acidification of the oil, which causes slow disintegration of the varnish protecting the compressor motor windings.

#### **6.2.1.3 - High and low pressure gauges (option): Enables instantaneous readout of suction and discharge pressures.**

Sight glass/humidity indicator: (optional on units fitted with scroll type or reciprocating compressors) :

- Enables visual verification of the state of the liquid refrigerant (monophase ou diphasic) in the liquid line, upstream of the thermostatic expansion valve.
- Enables detection of humidity in the circuit.

#### **6.2.1.4 - Crankcase heater:**

Every compressor is fitted with a single phase crankcase heater that is activated when the compressor stops to ensure separation of the refrigerant and the compressor oil. It is therefore powered up when the compressor is not running.

NB : Scroll and reciprocating +6°C ambient type compressors are not fitted with a crankcase heater.

#### **6.2.1.5 - High pressure switch:**

This pressure switch initiates unconditional stoppage of the unit if compressor discharge pressure exceeds the operating limits. Reset is automatic.

- Screw and reciprocating compressor with R407C high pressure switch equal 26.5 bars
- Scroll compressor with R407C high pressure switch equal 29 bars

#### **6.2.1.6 - Low pressure switch (if installed)**

This pressure switch initiates unconditional stoppage of the unit if if evaporating pressure drops below the value P.

- 1) +6°C ambient temperature machines (standard) P = 2,4 bars relative
- 2) Optional -20°C ambient temperature machines P = 0,8 bars relative

**6.2.1.7 - Fan control pressure switch and thermostat:**

The function of these devices is to ensure a level of head pressure compatible with proper unit operation. An increase in outdoor air temperature increases head pressure, and this is maintained at its required value by fan operation.

**6.2.1.8 - Antifreeze function:**

This function only exists on units designed for brine or glycol/water chilling for which the freezing temperature depends on the concentration of the solution.

Whatever type of device is used (see case 1 and 2), cut-out by the antifreeze function causes immediate unit stoppage.

**CASE 1: Antifreeze thermostat:**

This device monitor chilled liquid temperature at the evaporator outlet. It triggers when the temperature goes below the minimum value (+ 4°C for water).

**CASE 2: Antifreeze pressure switch:**

This monitors evaporating pressure of the refrigerant. It triggers when the temperature goes below the preset minimum value.

Note: On units fitted with CLIMATIC control, see the appropriate user manual for more specific details.

**6.2.1.9 - Differential oil pressure safety switch: (only on units with semi-hermetic compressors)****a) Reciprocating compressors:**

This pressure switch initiates unconditional unit stoppage if differential oil pressure drops for more than two minutes below a pre-established minimum safety value.

Differential oil pressure is the difference between the oil pump discharge pressure and the gas pressure inside the compressor crankcase (suction pressure). The differential oil pressure safety switch is factory set and is not modifiable on site.

**b) Screw compressors:**

This pressure switch initiates unconditional unit stoppage if differential oil pressure rises above a preset safety value. Differential oil pressure in this case is high pressure less the compressor oil injection pressure.

**6.2.2 - Functions of electrical components****6.2.2.1 - Electronic or cam type anti-short cycle relay:**

This device limits the number of compressor start ups.

Compressor motor thermal protection:

This device stops the motor if winding temperature rises too high and enables it to start up again when temperature drops back to a normal value.

**6.2.2.2 - Fan over current protection:**

Circuit breaker designed to stop the fan motors in the event of phase over current in relation to the permitted value.

**6.2.2.3 - Compressor motor over current protection:**

Circuit breaker designed to protect each motor winding against accidental over current.

**6.2.2.4 - Indicator lights:**

The electrical control box is fitted with indicator lights enabling visualisation of the state of operation or non operation of a function or given circuit.

There is also an indicator to show that the unit is powered up, an emergency stoppage indicator for each compressor, an indicator to show stoppage of the compressor via the regulating system (through the main control thermostat which is sensitive to chilled water temperature), a run light per compressor, and a general fan default stoppage indicator (on air cooled units).

On units with CLIMATIC control, see the appropriate manual.



#### **6.2.2.5 - Time delay relay for starting compressor motors one winding at a time (option) :**

This optional relay is supplied on units ordered with the part winding start system. The time delay between starting the first winding and the second winding cannot exceed 0.8 seconds.

#### **6.2.2.6 - Chilled liquid pump interlock:**

This interlock is made only if the the pump is supplied with the liquid chiller. As soon as the unit is powered up and the remote on/off for the unit is validated, the pump starts running. Prior operation of the pumps is mandatory for compressor operation.

Note: on units with CLIMATIC control, control of 1 or 2 water pumps is catered for by the control program.

#### **6.2.2.7 - Flow switch for the chilled liquid (option) :**

This control device initiates unconditional unit stoppage as soon as the flow of chilled liquid (water, brine, etc...) ensured by the pump becomes insufficient, since this could cause rapid evaporator freeze up. When the contact opens due to a lack of flow the unit must stop immediately.

If the purchaser installs a flow switch himself, electrical connections should be made to the two remote interlock terminals (dry contact).

### **6.2.3 - Automatic sequences**

#### **6.2.3.1 - Starting sequence:**

- Press the unit start switch, the power light will come on ; The control circuit cannot be energised if there is no power supply to the main power circuit.
- Depending on the demand for cooling, the control thermostat authorises start up of the compressor(s), which takes place in sequence. The compressor run indicating lights come on.

#### **6.2.3.2 - Regulator stoppage sequence:**

When the cooling load starts decreasing from its maximum value, the multi-stage control thermostat shuts down successive stages depending on the progressive reduction in return chilled liquid temperature.

Depending on machine equipment, staged reduction consists either in shutting down a compressor or activation of a compressor capacity reducer. This continues until the unit shuts down completely through action of the regulator. The compressor regulation stoppage lights come on.

#### **6.2.3.3 - Safety shutdown sequence:**

If a default occurs on a circuit, it is detected by the appropriate safety device, (high pressure overshoot, loss of oil pressure, motor protection, etc...) The relay in question initiates unconditional stoppage of the compressor on that circuit and the safety stoppage indicating light comes on.

Some defaults give rise to immediate stoppage of the entire unit :

- Tripped flow switch,
- Tripped antifreeze thermostat
- ...etc....

In cases other than that of manually reset safety devices, starting up of the circuit or the machine takes place automatically once the default has been cleared.

#### **6.2.3.4 - Loss of power supply:**

There are no problems restarting the machine after a loss of power supply of short duration (up to about one hour). If loss of power supply lasts longer than this, when power supply is resumed set the unit to «OFF» with the compressor crankcase heaters activated for as long as it takes to bring sump oil back up to temperature, then restart the unit.

#### **6.2.3.5 - Condensing Pressure control water valve:**

This device is available as an option for low capacity water cooled condensing units (MCW)

The high pressure control water valve should be installed on the condenser outlet. It enables water flow through the heat exchanger to be varied so as to maintain condensing pressure at an appropriate value.



6.2.3.6 - Fan motor control:

ECOLOGIC - Fans electrical box labelling.

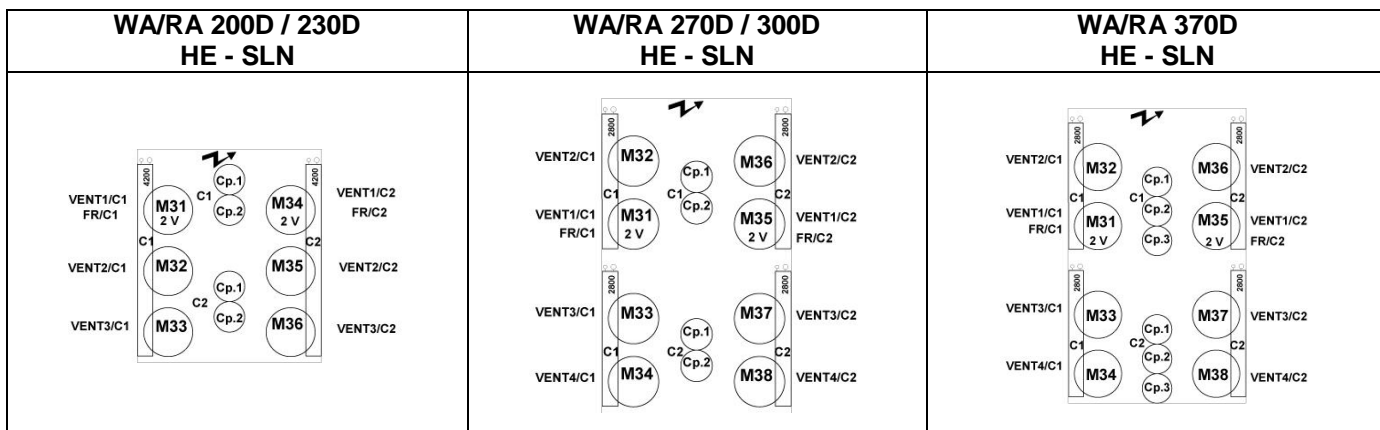
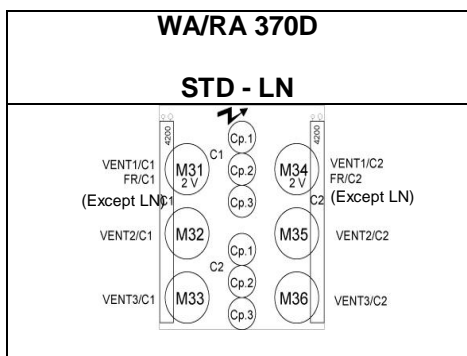
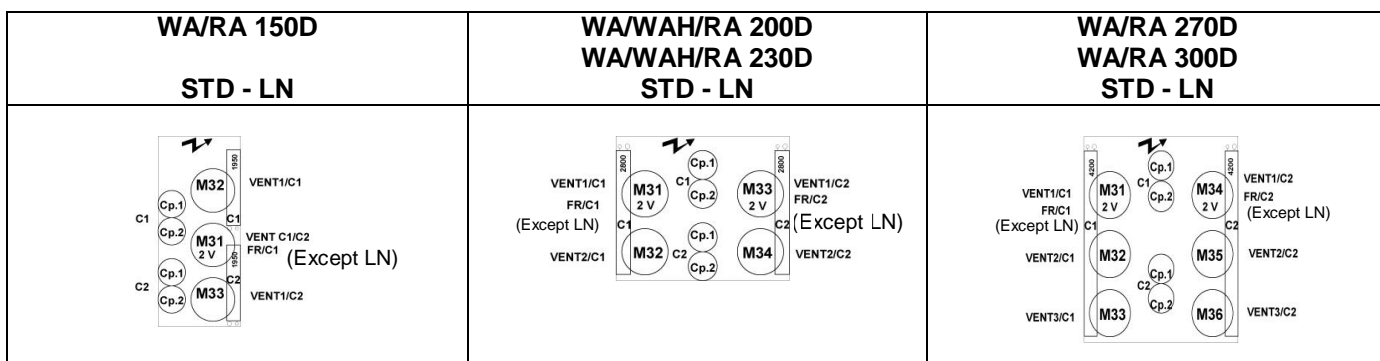

**Special units with screw compressors - Fans electrical box labelling**

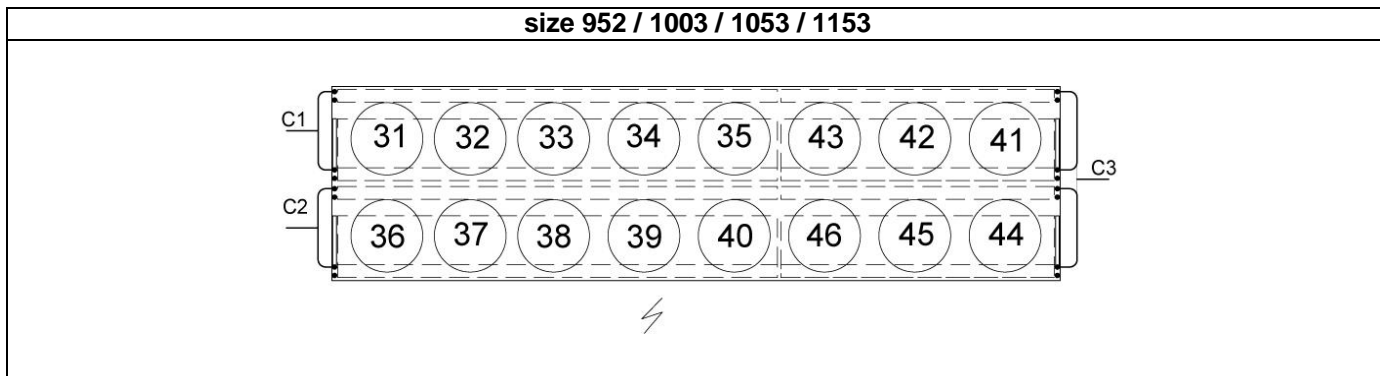
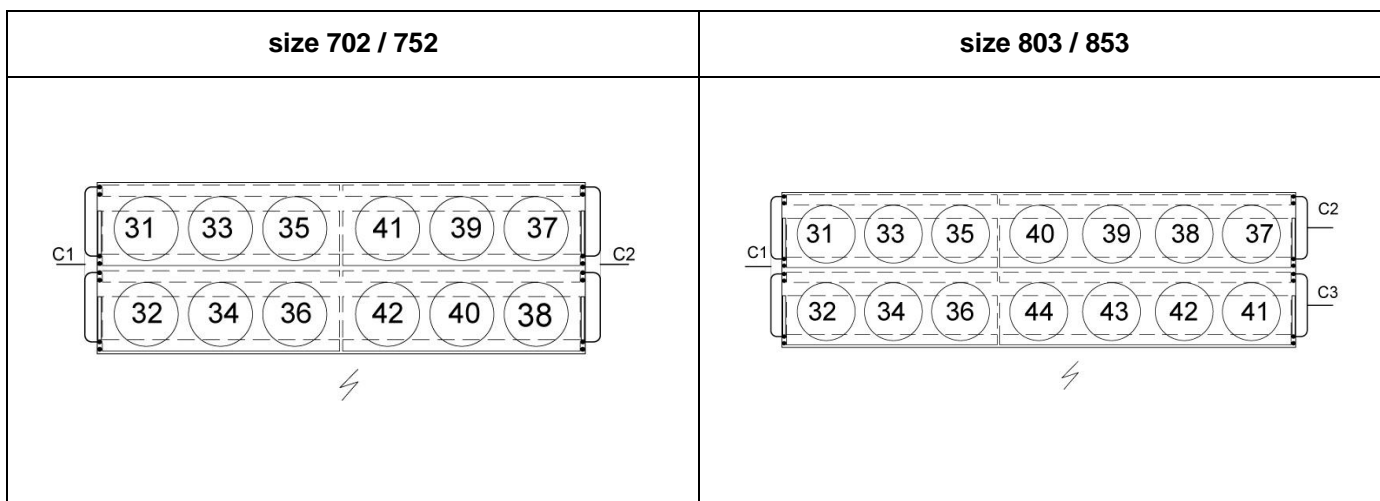
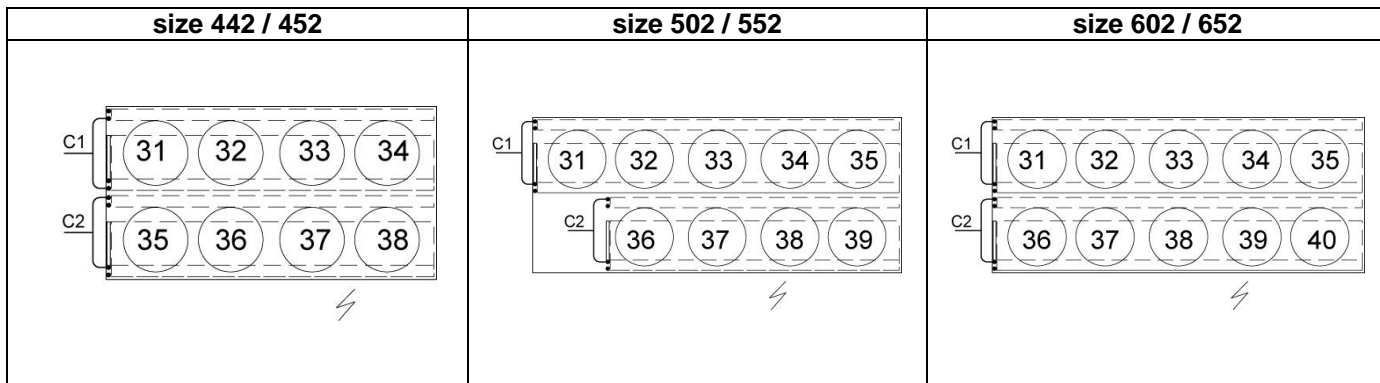

## MAINTENANCE

### 7. MAINTENANCE

**Warning :**

During the life-time of the system, inspection and tests must be carried out in accordance with national regulations. The information on operating inspections given in annex C of standard EN378-2 can be used if no similar criteria exist in the national regulations.

The following maintenance instructions form a part of the operations required for this type of equipment.

However, It is not possible to give fixed and precise rules for permanent maintenance procedures capable of keeping all units in perfect operating condition since too many factors depending on local conditions specific to the installation, the way the machine is operated, the frequency of operation, climatic conditions, atmospheric pollution, etc. Only trained experienced personnel can establish strict maintenance procedures adapted to the conditions listed above. Nonetheless, we recommend a regular maintenance schedule :

- 4 times a year for chillers operating all year long
- 2 times a year for chiller that only operate during the cooling season

All operations must be performed in conformity with the maintenance plan; this will extend the service life of the unit and reduce the number of serious and costly breakdowns.

It is essential to keep a «service log», for weekly records of operating conditions of the machine. This log will serve as an excellent diagnostic tool for maintenance people; likewise, the machine operator, by noting down changes in machine operating conditions, will often be able to anticipate and avoid problems before they actually occur or worsen.

The manufacturer cannot be held responsible for any malfunctioning of any equipment it provides if it is caused by a lack of maintenance or by operating conditions beyond those recommended in this manual.

Shown below, and as an illustration only, are some of the most common rules applied for maintenance.

#### 7.1 WEEKLY MAINTENANCE

- 1) Check the compressor oil level. This should be visible through the sightglass with the machine running at full load. Let the compressor operate for 3 to 4 heures before adding any oil. Check the oil level every 30 minutes. If the level does not reach the level indicated above, contact a qualified refrigeration mechanic.  
Caution, for units equipped with tandem or trios scroll compressors, the oil level must be checked - and visible - while the compressors are stopped. The oil level with running compressors is not relevant.
- 2) Overcharging with oil can be as dangerous to a compressor as a lack of oil. Before topping up, contact a qualified technician. Only use oils recommended by the manufacturer. See §3.7.6.
- 3) Check the oil pressure.
- 4) The flow of liquid refrigerant through the sightglass should be steady and without bubbles. Bubbles are a sign of a low charge, a possible leak, or of a restriction in the liquid line. Contact a qualified technician.

Each sightglass is fitted with a humidity indicator. The colour of the element changes according to the level of humidity in the refrigerant, but also according to temperature. It should indicate «dry refrigerant. If it shows «wet» or «CAUTION», contact a qualified refrigeration technician.

**CAUTION :** When starting up the unit, run the compressor for at least 2 hours before taking a humidity reading. The humidity detector is also sensitive to temperature, and as a consequence, the system must be at normal operating temperature to give a meaningful reading.

- 5) Check operating pressures. If they are higher or lower than those recorded when the machine was put into service, see the chapter 8.
- 6) Inspect the entire system so as to detect any eventual abnormality: noisy compressor, loose casing panels, leaky pipes or juddering contacts.
- 7) Record temperatures, pressures, dates et times and any other observations in the service log.
- 8) Leak detection is recommended.

## 7.2 ANNUAL MAINTENANCE

It is important that units are serviced regularly by a qualified technician, at least once every year or every 1000 hours of operation.

Failure to observe this rule can lead to cancellation of the warranty and will clear LENNOX of whatever responsibility.

A service visit by a qualified technician is also recommended after the first 500 hours of operation after the unit is first put into service.

- 1) Inspect valves and piping. Clean the filters if necessary, clean the condenser tubes (see «cleaning the condenser» §7.3).
- 2) Clean the chilled water piping filters.

**CAUTION:** The chilled water circuit may be pressurised. Observe the usual precautions when depressurising the circuit before opening it. Failure to observe these rules could lead to accidents and cause injury to service personnel.

- 3) Clean any corroded surfaces and repaint them.
- 4) Inspect the chilled water circuit for any signs of leakage.

Check operation of the water circulating pump and its ancillaries.

Check the percentage of antifreeze in the chilled water circuit, top up as necessary (if antifreeze is used).

- 5) Carry out all weekly maintenance duties.

Every year, the first and last inspection will include the seasonal shutdown procedure or the restarting procedure depending on the case.

These inspections should include the following operations:

- Check the contacts of motor contactors and control devices.
- Check the adjustment and operation of each control device.
- Conduct an oil analysis to determine the acidity. Record the results.
- Change the oil if necessary.

**WARNING :** Oil analyses should be carried out by a qualified technician. Misinterpretation of the results could cause damage to the equipment.

Also, analysis operations should be conducted according to the right procedures, so as to avoid accidents and potential injury of service personnel.

- Follow the recommendations given by LENNOX as concerns compressor oil (see the appropriate table).
- Conduct a refrigerant leak test.
- Check motor winding isolation.

Other operations may be necessary depending on the age and the number of hours of operation of the installation.

## 7.3 CLEANING THE CONDENSER

### 7.3.1 Air cooled condensers

Clean the coils either with a vacuum cleaner, cold water, compressed air, or with a soft brush (non metallic). On units installed in a corrosive atmosphere, coil cleaning should be part of the regular maintenance program. On this type of installation, all dust gathered on the coils should be quickly removed by regular cleaning. **Caution:** Except for Neosys range with MCHx coils, do not use high pressure cleaners that could cause permanent damage to the aluminium coil fins.

### 7.3.2 Multitube water cooled condensers

Use a cylindrical brush to remove sludge and other substances in suspension inside the condenser tubes. Use a non corrosive solvent to remove scale deposits.

The water circuit in the condenser is manufactured in steel and copper. A water treatment specialist, given the right information, will be able to recommend the right solvent for removing scale.

The equipment to be used for external water circulation, the quantity of solvent and the safety measures to be taken must be approved by the company supplying the cleaning products or by the company conducting these operations.

## **7.4 COMPRESSORS / OIL DRAINAGE**

Oil for refrigeration equipment is clear and transparent. It keeps its colour over a long period of operation.

Given that a correctly designed and installed refrigeration system will operate without any problems, there is no need to replace the compressor oil even after a very long period of operation.

Oil that has become dark in colour has been exposed to impurities in the refrigeration piping system or to excessive temperatures on the discharge side of the compressor, and this inevitably impairs the quality of the oil. Darkening of the colour of the oil or degradation of its qualities can also be caused by the presence of humidity in the system. When the oil has changed colour or has been degraded, it must be changed.

In this event, before putting the unit back into service, the compressor and the refrigeration circuit will have to be evacuated.

## **7.5 IMPORTANT**

Before proceeding with any service operations, make sure that the power supply to the unit is switched off.

When the refrigeration circuit has been opened it will have to be evacuated, recharged, and inspected to ensure that it is perfectly clean (filter-drier) and leaktight. Remember that only trained and qualified personnel are authorised to open a refrigeration circuit.

Regulations stipulate recovery of refrigerants and forbid willful discharge of refrigerants into the atmosphere.

## TROUBLESHOOTING – REPAIRS

### 8.1 LIST OF THE MOST COMMON PROBLEMS

PROBLEMS – SYMPTOMS	PROBABLE CAUSE	RECOMMENDED ACTION
<b>A) THE COMPRESSOR DOES NOT START</b>		
- Motor control circuits established, the compressor does not run	- No power supply	- Check main power supply and switch positions
	- Compressor motor burnt out	- Replace
- Low voltage reading on voltmeter	- Voltage too low	- Contact power company
- The system does not start up	- Breaker tripped or fuses blown	- Determine the cause. If the system is in running order, close the disconnect
		- Check condition of fuses
	- No water flow in the evaporator	- Measure flow, check the water pump and water circuitry and filters
	- Flow switch contacts open	- Find the cause of the trip out
		- Check circulation of liquid in the evaporator, and the condition of the flow switch
	- Anti short cycle relay action	- Wait until the anti short cycle time delay has expired
	- Faulty control thermostat	- Check for proper operation, set points, contacts
	- Oil pressure switch tripped	- Check the oil pressure switch and determine the cause of the trip out
	- Antifreeze thermostat or low pressure safety switch tripped	- Check evaporating pressure, the condition of the antifreeze thermostat and the low pressure safety switch
	- Compressor thermal protection relay tripped	- Check for proper operation of the relay
- High pressure safety switch tripped	- Check the condensing pressure, and the condition of the high pressure safety switch	

## 8.1 LIST OF THE MOST COMMON PROBLEMS – CONTINUED

PROBLEMS – SYMPTOMS	PROBABLE CAUSE	RECOMMENDED ACTION
<b>B) THE COMPRESSOR DOES NOT START</b>		
	- Low pressure safety switch trip out	- Check low pressure safety switch differential
- Normal operation with too frequent starts and stoppages due to action of the low pressure safety switch. Bubbles in sightglass.  Or, normal compressor operation, but the low pressure safety switch trips out and resets frequently	- Low refrigerant charge	- Check the charge through the sightglass on the liquid line, carry out a leak test, then top up the refrigerant charge
- Suction pressure too low, Filter drier frozen up	- Filter-drier obstructed	- Check the state of the drier and replace the filter
	- Solenoid valve closed	- Check that the valve is operating properly
	- Expansion valve closed	- Check bulb and capillaries, operation of the valve
	- Compressor suction valve	- Check the filter

<b>C) THE COMPRESSOR SHORT CYCLES ON HIGH PRESSURE SAFETY SWITCH TRIP OUT</b>		
	- High pressure safety switch trip out	- Check high pressure safety switch differential
	- Low air/water flow in condenser or dirty condenser coil (poor heat exchange)	- Check that pumps are operating correctly or the state of cleanliness of the coils / check fan operation
	- Incondensibles in the refrigeration circuit	- Bleed from circuit and top up the refrigerant charge.  Note : it is not permitted to discharge refrigerant to atmosphere

## 8.1 LIST OF THE MOST COMMON PROBLEMS – CONTINUED

PROBLEMS – SYMPTOMS	PROBABLE CAUSE	RECOMMENDED ACTION
<b>D) THE COMPRESSOR RUNS IN LONG CYCLES OR RUNS CONTINUOUSLY</b>		
	- Faulty control thermostat	- Check operation
- Temperature too low in the conditioned space	- Chilled water thermostat set too low	- Adjust it
- Bubbles in sightglass	- Low refrigerant charge	- Check the refrigerant charge in the sightglass and top up if necessary
	- Filter-drier partly obstructed	- Check the drier and replace as required, change the filter cartridge
	- Expansion valve partly closed	- Check expansion valve bulb and capillary, measure superheat
	- Liquid line valve not open far enough	- Open the valve completely
- Noisy compressor, or abnormally high suction pressure or low discharge pressure	- Leaky compressor valves	- Check valve gas-tightness, replace the valve plate if necessary. Tighten compressor nuts and bolts

<b>E) THE COMPRESSOR CUTS OUT ON OIL PRESSURE SAFETY SWITCH</b>		
	- Oil pressure switch tripped	- Check operation of the oil pressure safety switch
- Oil level in sightglass is too low	- Oil pressure too low	- Check the oil level in the sightglass on the crankcase, check the cleanliness of the oil filter, check the oil pump
- Visible oil leak / Oil level too low	- Low oil charge	- Check that there is no leakage and add oil
	- Leaky oil sump	- Repair and add oil
- Suction line unusually cold, compressor noisy	- Liquid refrigerant present in the compressor crankcase	- Check appearance of the oil in the sightglass. Measure temperature of the oil pump, measure superheat at the expansion valve, check that the valve bulb is tightly attached
	- Poor heat exchange in the evaporator	- Check water flow. Check fouling by measuring the water pressure drop. Excessive oil migration in the circuit : measure evaporating pressure, superheat and the temperature of the oil pump



## 8.1 LIST OF THE MOST COMMON PROBLEMS – CONTINUED

PROBLEMS – SYMPTOMS	PROBABLE CAUSE	RECOMMENDED ACTION
<b>F) THE COMPRESSOR CUTS OUT ON ANTIFREEZE PRESSURE SWITCH</b>		
	- Antifreeze pressure switch tripped	- Check that the pressure switch is operating properly
	- Low water flow in the evaporator	- Check the water pump
	- Evaporator obstructed	- Determine the degree of fouling by measuring water pressure drop
	- Evaporator frozen up	- Measure pressure drop in water circuit, keep water circulating until evaporator has thawed completely
	- Low refrigerant charge	- Check the refrigerant charge and add refrigerant if necessary

<b>G) THE COMPRESSOR CUTS OUT ON ITS MOTOR PROTECTION THERMAL RELAY</b>		
	- Thermal protection Tripped	- Check operation of thermal protection, change it if necessary
	- Motor windings are not being sufficiently cooled	- Measure superheat in the evaporator, adjust it if necessary

<b>H) COMPRESSOR CUTS OUT THROUGH ACTION OF THE MAIN POWER FUSE</b>		
	- Power supply on two phases only	- Check power supply voltage
	- Faulty motor windings	- Replace the compressor
	- Compressor seized	- Replace the compressor

<b>I) THE COMPRESSOR STARTS WITH DIFFICULTY</b>		
	- Faulty windings	- Replace the compressor
	- Mechanical problem	- Replace the compressor

## 8.1 LIST OF THE MOST COMMON PROBLEMS – CONTINUED

PROBLEMS – SYMPTOMS	PROBABLE CAUSE	RECOMMENDED ACTION
<b>J) THE COMPRESSOR IS NOISY</b>		
	- If starting on a single winding on compressors fitted with part winding start or wye-delta	- Check operation of the starter contacts, the start up time delay and the condition of the windings
- Compressor knocking	- Broken mechanical parts inside compressor	- Replace the compressor
- Suction line is unusually cold	a) Liquid slugging	a) Check superheat and that the expansion valve bulb is correctly installed
	b) Expansion valve blocked in open position	b) Repair or replace
	- Broken suction valves	- Replace broken valves
- High discharge pressure. The water regulating valve or the pressure operated water valve taps or knocks	- Pressure operated water valve fouled, water pressure is too high or irregular	- Clean the valve. Install and expansion tank upstream of the valve
- Compressor shuts down through action of the oil pressure safety switch	- Low oil charge	- Add oil

<b>K) DISCHARGE PRESSURE TOO HIGH</b>		
- Water is far too hot at condenser outlet	- Water flow too low or water temperature too high in the condenser	- Adjust the pressure operated water valve or the thermostat on the cooling tower
- Water is far too cold at the condenser outlet	- Condenser tubes fouled	- Clean the tubes
- Condenser abnormally hot	- Presence of air or incondensibles in the circuit, or excessive refrigerant charge	- Purge incondensibles and/or air, and recover excess refrigerant
- Chilled water leaving temperature too high	- Excessive cooling load	- Reduce load, reduce water flow if necessary

<b>L) DISCHARGE PRESSURE IS TOO LOW</b>		
- Water is very cold at condenser outlet	- Condenser water flow too high or water temperature is too low	- Adjust the pressure operated water valve or the thermostat on the cooling tower
- Bubbles in sightglass	- Low refrigerant charge	- Repair the leak and add refrigerant

## 8.1 LIST OF THE MOST COMMON PROBLEMS – CONTINUED

PROBLEMS – SYMPTOMS	PROBABLE CAUSE	RECOMMENDED ACTION
<b>M) SUCTION PRESSURE IS TOO HIGH</b>		
- The compressor runs continuously	- Too much cooling demand on the evaporator	- Check the system
- Suction line unusually cold. Liquid refrigerant returns to compressor	a) Expansion valve opened to far	a) Adjust superheat and check that the expansion valve bulb is correctly fitted in place
	b) Expansion valve blocked in open position	b) Repair or replace

<b>N) SUCTION PRESSURE IS TOO LOW</b>		
- Bubbles in sightglass	- Low refrigerant charge	- Repair the leak and add refrigerant
- Excessive pressure drop across the filter-drier or the solenoid valve	- Filter-drier obstructed	- Replace the cartridge
- No refrigerant passing through the expansion valve	- Expansion valve bulb has lost its charge.	- Replace the bulb
- Loss of capacity	- Expansion valve obstructed	- Clean or replace
- Conditioned space too cold	- Control thermostat contacts stuck in closed position	- Repair or replace
- Compressor short-cycling	- Capacity modulation setting too low	- Adjust
- Superheat value too high	- Excessive pressure drop in the evaporator	- Check the external equalizing line on the expansion valve
- Low pressure drop in the evaporator	- Low water flow	- Check water flow. Check the condition of the filters, look for obstructions in the chilled water circuit piping

## 8.2 CONTROL DEVICES

### Operation

By reacting to compressor discharge pressure, the high pressure sensor monitors efficiency of the condenser. Poor efficiency, the result of an excessive condensing pressure, is usually caused by :

- A dirty condenser
- Low water flow (in case of water cooled unit)
- Low air flow (in case of air cooled unit)

The low pressure switch monitors the pressure at which the refrigerant evaporates in the evaporator tubes.

Low evaporating pressure is usually caused by :

- Low refrigerant charge
- A faulty expansion valve
- An obstructed liquid line filter-drier
- A damaged compressor cylinder bank unloader.

The control thermostat monitors chilled water temperature at the evaporator inlet. The most common causes of subnormal temperatures in this zone are:

- Low water flow
- Thermostat setting too low

The oil pressure switch monitors oil injection pressure on the compressor.

Low oil pressure is usually caused by :

- Low oil charge
- A worn or faulty oil pump
- A defective crankcase heater, causing condensation of refrigerant in the oil sump.

**The above information does not represent a complete analysis of the refrigeration system. It is intended to familiarise the operator with unit operation and to provide him with the technical data required to enable him to recognise, correct or report a fault.**



**Only trained and qualified personnel is authorised to service and maintain this equipment.**

## 8.3 MANUFACTURER'S RECOMMENDED INSPECTIONS

### 8.3.1 - LIQUID CHILLERS WITH RECIPROCATING COMPRESSOR(S)

#### 8.3.1.1 - Number of recommended preventive maintenance visits :

#### NUMBER OF RECOMMENDED PREVENTIVE MAINTENANCE VISITS

Year	Start up	500/1000H visit	Major technical inspection	Inspection visit	15 000 h inspection	30000 h inspection	Tube analysis	
1	1	1		2				
2			1	3				
3			1	3				
4				3	1			
5			1	3			1 <sup>(1)</sup>	
6			1	3				
7				3		1		
8			1	3				
9			1	3				
10				3		1		1
+10					Every year	3 times a year	Every 15000 hours	Every 30000 hours

This table is published for units operating under normal conditions with an average annual runtime of 4000 hours. In hostile industrial environments, a specific maintenance visit schedule must be envisaged.

(1) Depending on the quality of the water

### 8.3.1.2 - Description of inspection duties - Liquid chiller with reciprocating compressor(s)

## START UP

- Check unit installation
- Check water flow and water circuit ancillaries
- Check safety devices
- Check leaktightness
- Configuration of the microprocessor based management system (if used)
- Verification of operating parameters and unit performance
- Transmission of the machine service log

## 500 H / 1000 H VISITS

- Post wear in inspection
- Oil acidity test, leak test
- Replacement of the filter-drier cartridges depending on the results of the test above.
- Monitor unit performance and any eventual variations linked to use of the installation.

## INSPECTION VISIT

- Leak test
- Operating test with record of measurements taken and functional analysis.

## MAJOR TECHNICAL INSPECTION

- Inspection visit
- Acid test
- Oil change if necessary
- Replacement of filter-drier cartridges if necessary
- Check up on the microprocessor based management system (if used)
- Adjustment of safety devices
- Verification of unit interlocks
- Lubrication of bearings / dampers if necessary

## 15 000 H VISIT

- Major technical inspection
- Inspection of the compressor and replacement of valves, springs and seals (depending on the type of compressor).

## 30 000 H VISIT

- Major technical inspection
- Inspection of the compressors with replacement of the valves, springs, seals and gaskets, bearings, oil discharge valve, piston rings.
- Dimensional inspection of the big ends and gudgeon pins, replacement of parts as required (quotation) (depending on the type of compressor).

## TUBE ANALYSIS

- Inspection of water cooled evaporator and condenser tube bundles with an eddy current test to enable potentially serious problems to be anticipated.
- Frequency : Every 5 years up to 10 years (depending on the quality of water), then every 3 years.

## 8.3.2 - LIQUID CHILLERS WITH SCROLL COMPRESSOR(S)

### 8.3.2.1 - Number of recommended preventive maintenance visits :

<b>NUMBER OF RECOMMENDED PREVENTIVE MAINTENANCE VISITS</b>
--

Year	Start up	500/1000H visit	Major technical inspection	Inspection visit	Tube analysis
1	1	1		2	
2			1	3	
3			1	3	
4				3	
5			1	3	1 <sup>(1)</sup>
6			1	3	
7			1	3	
8			1	3	
9			1	3	
10			1	3	1
+10					Every year

This table is published for units operating under normal conditions with an average annual runtime of 4000 hours. In hostile industrial environments, a specific maintenance visit schedule must be envisaged.

(1) Depending on the quality of the water

### 8.3.2.2 - Description of inspection duties - Liquid chiller with scroll compressor(s)

## START UP

- Check unit installation
- Check water flow and water circuit ancillaries
- Check safety devices
- Check leaktightness
- Configuration of the microprocessor based management system (if used)
- Verification of operating parameters and unit performance
- Transmission of the machine service log

## 500 H / 1000 H VISITS

- Post wear in inspection
- Oil acidity test, leak test
- Replacement of the filter-drier cartridges depending on the results of the test above.
- Monitor unit performance and any eventual variations linked to use of the installation.

## INSPECTION VISIT

- Leak test
- Operating test with record of measurements taken and functional analysis.

## MAJOR TECHNICAL INSPECTION

- Inspection visit
- Acid test
- Oil change if necessary
- Replacement of filter-drier cartridges
- Check up on the microprocessor based management system (if used)
- Adjustment of safety devices
- Verification of unit interlocks
- Lubrication of bearings / dampers if necessary

## TUBE ANALYSIS

- Inspection of water cooled evaporator and condenser tube bundles with an eddy current test to enable potentially serious problems to be anticipated.
- Frequency : Every 5 years up to 10 years (depending on the quality of water), then every 3 years.



### 8.3.3 - LIQUID CHILLERS WITH SCREW COMPRESSOR(S)

#### 8.3.3.1 - Number of recommended preventive maintenance visits :

#### NUMBER OF RECOMMENDED PREVENTIVE MAINTENANCE VISITS

Year	Start up	500/1000H visit	Major technical inspection	Inspection visit	30000 h inspection	Tube analysis
1	1	1		2		
2			1	3		
3			1	3		
4				3		
5			1	3		1 <sup>(1)</sup>
6			1	3		
7				3	1	1
8			1	3		
9			1	3		
10				3		
+10					Every year	3 times a year

This table is published for units operating under normal conditions with an average annual runtime of 4000 hours. In hostile industrial environments, a specific maintenance visit schedule must be envisaged.

(1) Depending on the quality of the water

### 8.3.3.2 - Description of inspection duties - Liquid chiller with screw compressor(s)

## START UP

- Check unit installation
- Check water flow and water circuit ancillaries
- Check safety devices
- Check leaktightness
- Configuration of the microprocessor based management system
- Verification of operating parameters and unit performance
- Transmission of the machine service log

## 500 H / 1000 H VISITS

- Post wear in inspection
- Oil acidity test, leak test
- Replacement of the filter-drier cartridges depending on the results of the test above.
- Monitor unit performance and any eventual variations linked to use of the installation.

## INSPECTION VISIT

- Leak test
- Operating test with record of measurements taken and functional analysis.

## MAJOR TECHNICAL INSPECTION

- Inspection visit
- Acid test
- Oil change if necessary
- Replacement of filter-drier cartridges
- Check up on the microprocessor based management system
- Adjustment of safety devices
- Verification of unit interlocks
- Lubrication of bearings / dampers if necessary

## 30000 H VISIT

- Replacement of the compressor and return the old one for revision with replacement of bearing and inspection of compressor geometry
- Major technical inspection
- Start-up of the installation again

## TUBE ANALYSIS

- Inspection of water cooled evaporator and condenser tube bundles with an eddy current test to enable potentially serious problems to be anticipated.
- Frequency : Every 5 years up to 10 years (depending on the quality of water), then every 3 years.

# AIR COOLED CHILLERS AND SPLIT UNITS

## INSTALLATION

## OPERATION

## MAINTENANCE MANUAL

Ref : CHILLERS\_IOM-0708-E

# ANNEXES

### HYDRAULIC CIRCUIT DRAWINGS

NEOSYS range .....	51
ECOLOGIC range.....	53

### OPERATING LIMITS

NEOSYS range .....	57
ECOLOGIC range.....	59
Screw compressor chiller .....	60

### RISK ANALYSIS AND HAZARDOUS SITUATIONS ACCORDING TO 97/23/CE DIRECTIVE .....61

### REFRIGERATION CIRCUIT DRAWINGS

NEOSYS range .....	63
ECOLOGIC range.....	65

### CERTIFICATES

MIONS AFAQ ISO 9000 .....	67
PED .....	68
CE CONFORMITY.....	69

### START UP AND MAINTENANCE LOGBOOK

INSTALLATION CHECK LIST.....	70
START-UP CHECK SHEET .....	72
START-UP CONCLUSION .....	73
MAINTENANCE LOGBOOK .....	74
REFRIGERANT TRANSACTION LOGBOOK for F-GAS REGULATION.....	84

## NEOSYS - Hydraulic data

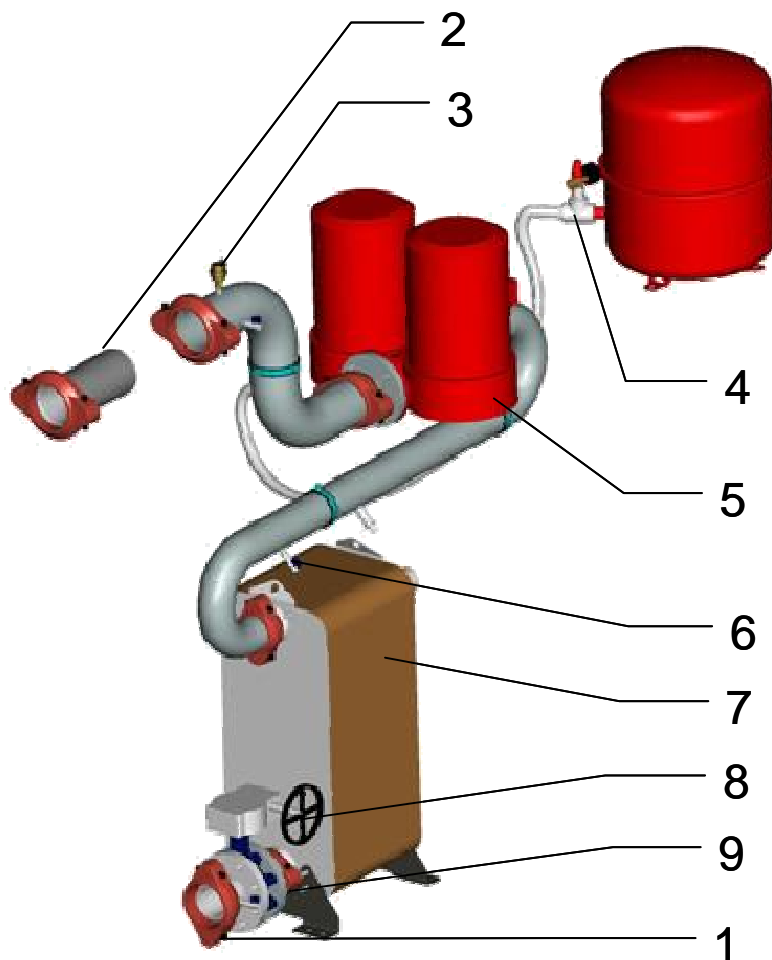

- 1- All Victaulic Connections
- 2- Inlet Filter (Supplied Loose)
- 3- Automatic Air Vent
- 4- Expansion Vessel, relief Valve & manometer
- 5- Single or Dual Pump, High or Low Pressure
- 6- New Electronic Stainless Steel Flow Switch
- 7- High Performance Stainless steel Evaporator
- 8- Pressure Adjustment Valve
- 9- Pressure Taps and drain Valve

# NEOSYS - Hydraulic data

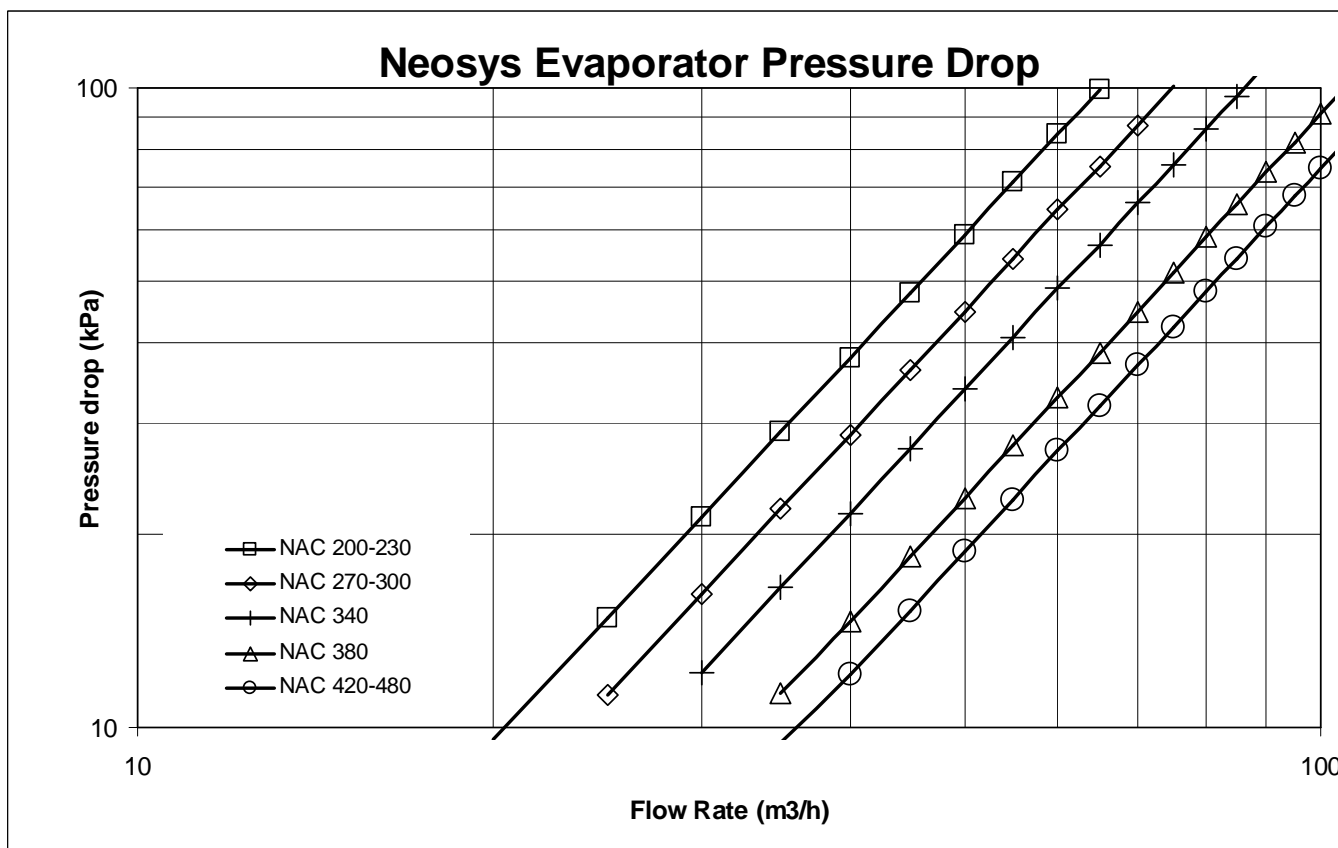
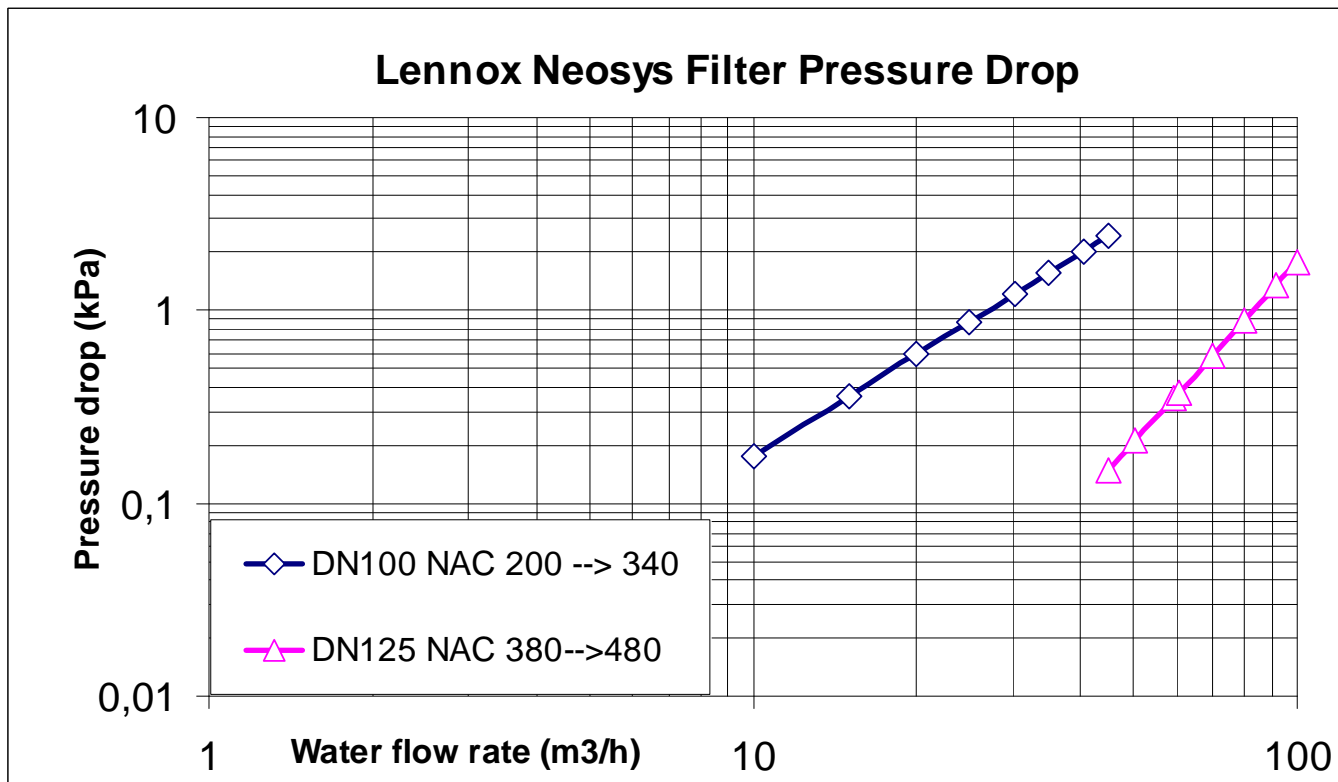

# ECOLOGIC - hydraulic/hydronic data

## UNIT WITHOUT HYDRAULIC OR HYDRONIC MODULE

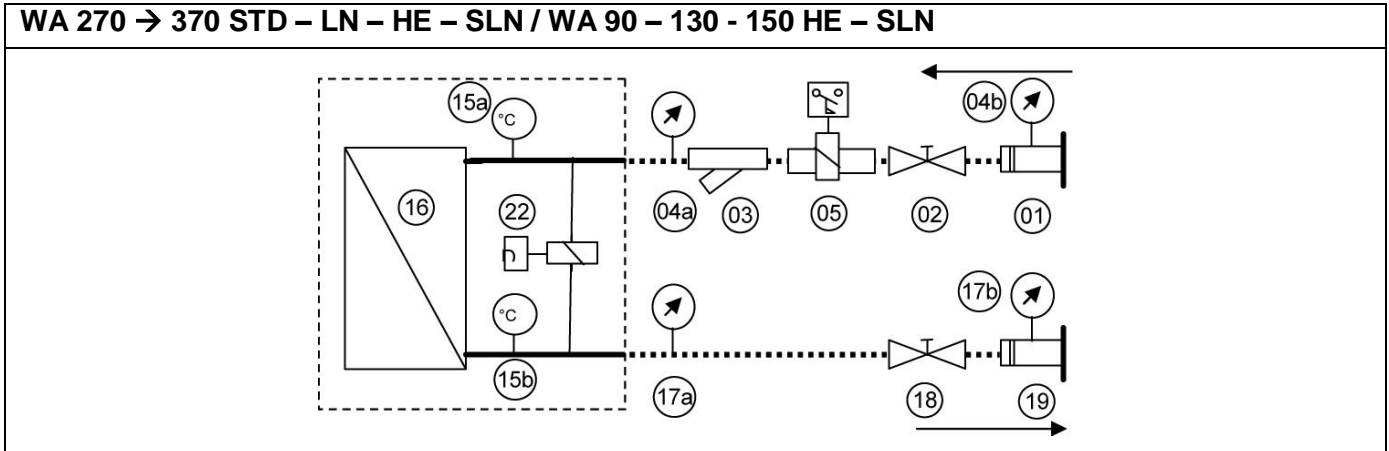

ITEMS SUPPLIED LOOSE			ITEMS MOUNTED INSIDE THE UNIT		
01	19	Groove lock coupling	15a	15b	Temperature sensors
02	18	Unit isolation valve	16		Plate heat exchanger
03		Water inlet filter	22		Flow switch/Differential
04a	17a	In/Out manometers without groove lock coupling option			
04b	17b	in/Out manometers mounted on groove lock coupling option			
05		Paddle flow switch			

OPTIONS				
BASIC UNIT	Water inlet filter	Flow switch (paddle) Supplied loose	Flow switch (differential) Supplied mounted	Unit isolation valve
	Add 03	Add 05	Add 22	Add 02/18
16 15a/15b	Kit for groove lock coupling	Inlet/Outlet manometer	Inlet/Outlet manometer + kit for groove lock coupling	
	Add 01/19	Add 04a/17a	Add 04b/17b & 01/19	

# ECOLOGIC - hydraulic/hydronic data

## UNIT WITH HYDRONIC MODULE

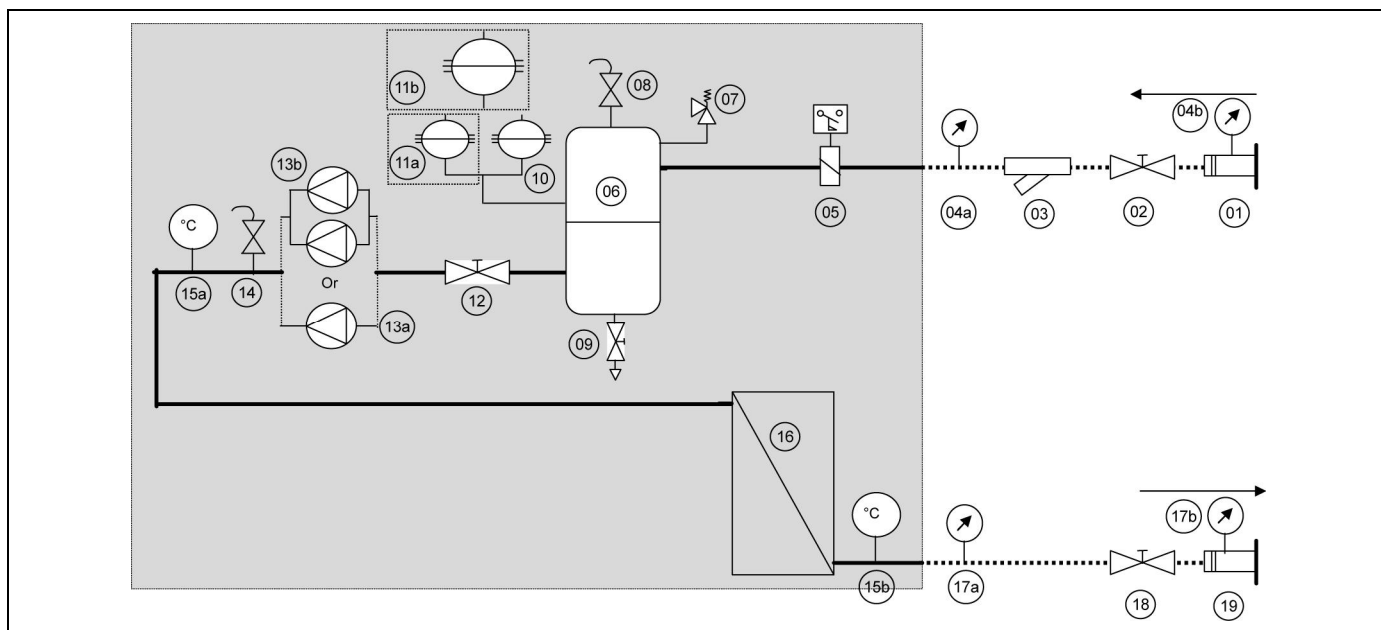

ITEMS SUPPLIED LOOSE			ITEMS MOUNTED INSIDE THE UNIT			
01	19	Groove lock coupling	05	Paddle flow switch	11b	Single 50L expansion vessel (WA ≤ 150D)
02	18	Unit isolation valve	06	Water tank 200L or 500L	12	Pump suction isolation valve
03		Water inlet filter	07	Safety valve	13a	Single pump
04a	17a	In/Out manometers without groove lock coupling option	08	Air purge	13b	Double pump
04b	17b	In/Out manometers mounted on groove lock coupling option	09	Water drain	14	Air purge
			10	25L expansion vessel	15a	Temperature sensor return
			11a	Second 25L expansion vessel for (WA > 150D)	15b	Temperature sensor supply
					16	Plate heat exchanger

	OPTIONS					
<b>BASIC UNIT + 200/500L tank and single or double pump</b>	Flow switch (paddle) mounted	Water inlet filter	Expansion vessel 25L	Expansion vessel 50L for 075/090/100/110 HE & SLN	Expansion vessel 50L for all other WA units	Pump isolation valve
	Add 05	Add 03	Add 10	Add 11b	Add 10/11a	Add 12/18
06/07/08/09/13a or 13b/14/15a/15b/16	Unit isolation valve	Pump + Unit isolation valve	Kit for groove lock coupling	Inlet/Outlet manometer	Inlet/Outlet manometer + kit for groove lock coupling	
	Add 02/18	Add 02/12/18	Add 01/16	Add 04a/17a	Add 04b/17b & 01/19	

# ECOLOGIC - hydraulic/hydronic data

## UNIT WITH HYDRAULIC MODULE

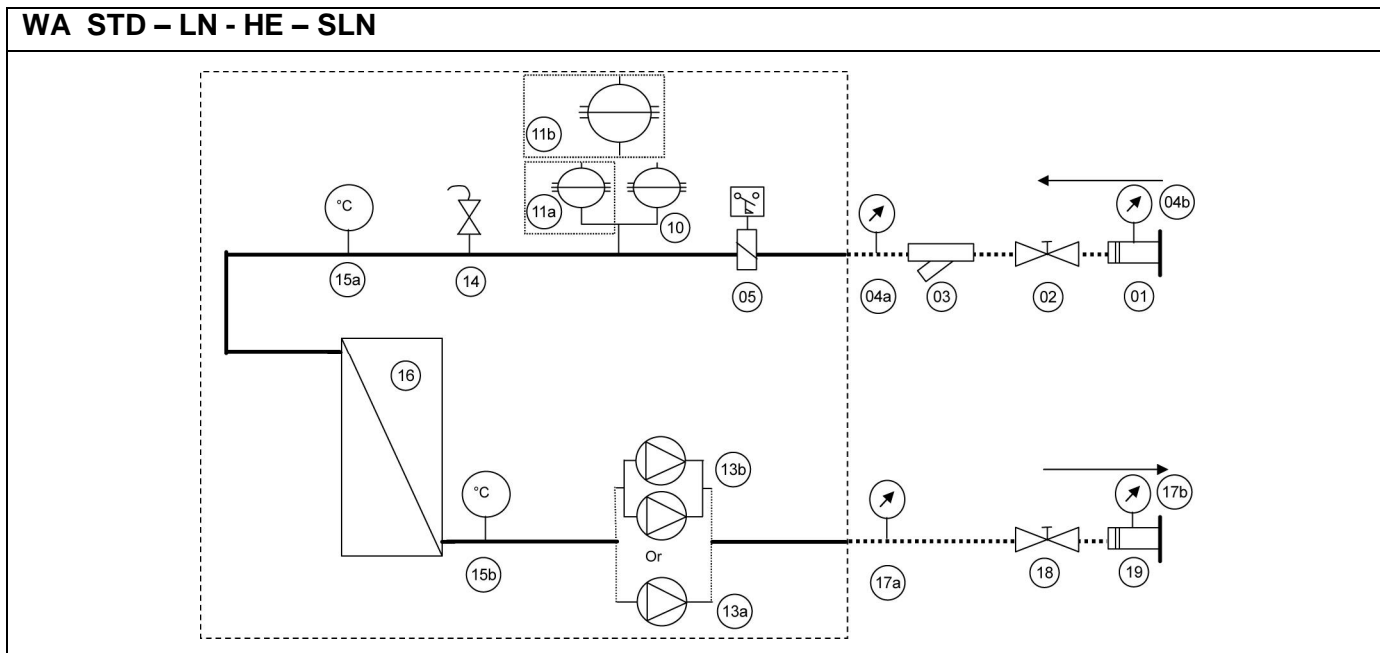

ITEMS SUPPLIED LOOSE		ITEMS MOUNTED INSIDE THE UNIT				
01	19	Groove lock coupling	05	Paddle flow switch	13a	Single pump
02	18	Unit isolation valve	10	25L expansion vessel	13b	Double pump
03		Water inlet filter	11a	Second 25L expansion vessel for (WA > 150D)	14	Air purge
04a	17a	In/Out manometers without groove lock coupling option	11b	Single 50L expansion vessel (WA ≤ 150D)	15a	Temperature sensor return
04b	17b	In/Out manometers mounted on groove lock coupling option			15b	Temperature sensor supply
					16	Plate heat exchanger

	OPTIONS				
<b>BASIC UNIT + Single or double pump</b>	Flow switch (paddle) mounted	Water inlet filter	Expansion vessel 25L	Expansion vessel 50L for WA 150 STD & 075/090/100/110 HE & SLN	Expansion vessel 50L for all other WA units
	Add 05	Add 03	Add 10	Add 11b	Add 10 & 11a
14/15a/15b/16/13a or 13b	Unit isolation valve	Kit for groove lock coupling	Inlet/Outlet manometer	Inlet/Outlet manometer + kit for groove lock coupling	
	Add 02/18	Add 01/19	Add 04a/17a	Add 04b/17b & 01/19	



# ECOLOGIC - hydraulic/hydronic data UNIT WITH FREE COOLING OPTION

## WA 150 STD – LN

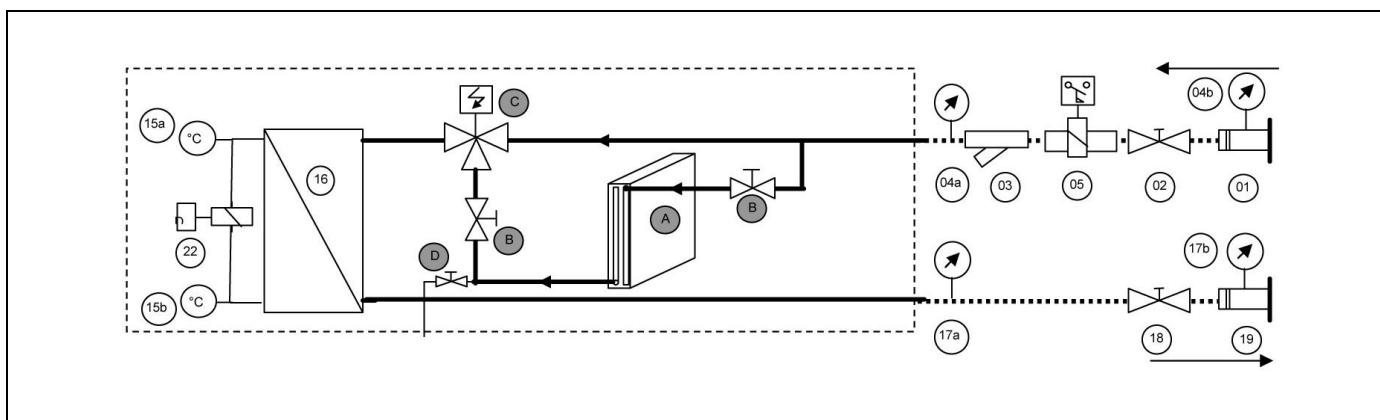

## WA 150 HE – SLN and 200/230/270/300/370 STD/LN/HE/SLN

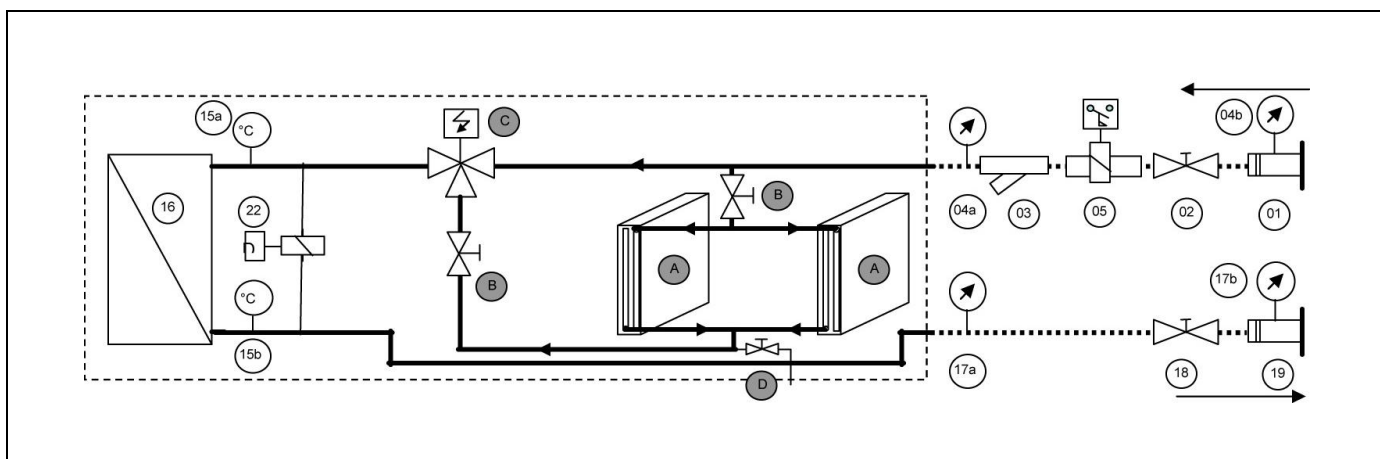

ITEMS SUPPLIED LOOSE		ITEMS MOUNTED INSIDE THE UNIT				
01	19	Groove lock coupling	16	Plate heat exchanger	A	Free cooling coil
02	18	Unit isolation valve	15a	Temperature sensor	B	Isolating valves
03		Water inlet filter	15b	Temperature sensor	C	Three way valve
04a	17a	In/Out manometers without groove lock coupling option	22	Flow switch/differential	D	Drain
05		Paddle flow switch				

BASIC UNIT	OPTIONS			
	16 15a/15b	Water inlet filter	Paddle flow switch Supplied loose	Differential flow switch Supplied mounted
	Add 03	Add 05	Add 22	Add 02/18
	Kit for groove lock coupling	Inlet/Outlet manometer	Inlet/outlet manometer + kit for groove lock coupling	
	Add 01/19	Add 04a/17a	Add 04b/17b and 01/19	

**NEOSYS - OPERATING LIMITS**

NAC		200	230	270	300	340	380	420	480
Min. outlet water temperature	°C	5							
Max. inlet water temperature	°C	20							
Min. difference water inlet/outlet	°C	3							
Max. difference water inlet/outlet	°C	8							
Min. outdoor air temperature	°C	6							
Min. outdoor air temperature with Low Ambient kit	°C	-10							
Maximum outside air temperature :									
• Normal operation Full Capacity	°C	46							

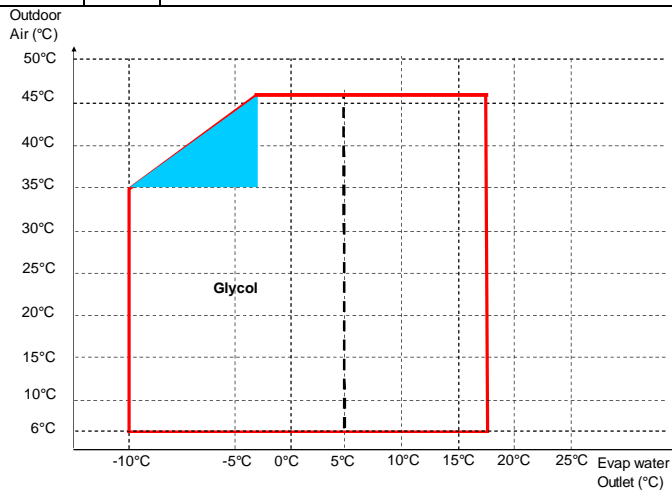

NAH COOLING MODE		200	230	270	300
Min. outlet water temperature	°C	5			
Max. inlet water temperature	°C	20			
Min. difference water inlet/outlet	°C	3			
Max. difference water inlet/outlet	°C	8			
Min. outdoor air temperature	°C	6			
Maximum outside air temperature :					
Normal operation Full Capacity	°C	46			

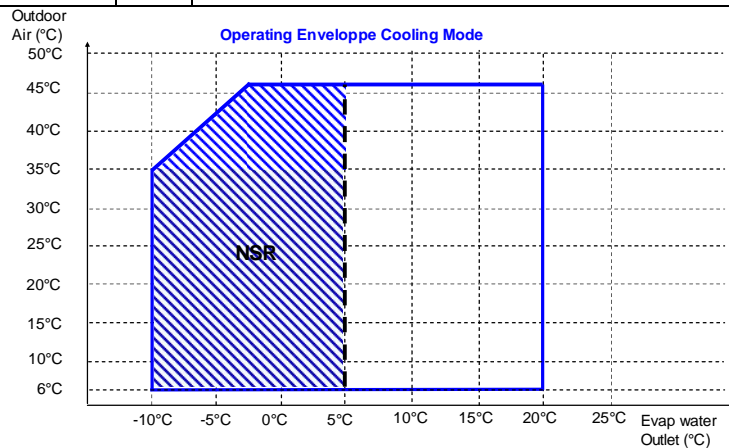

<b>NAH HEATING MODE</b>		200	230	270	300
Min. Cond outlet water	°C	24			
Max. Cond outlet water	°C	50			
Min. difference water inlet/outlet	°C	3			
Max. difference water inlet/outlet	°C	8			
Outside air Limits :					
Min. outside air temperature <b>with water outlet 37°C</b>		-12			
Max. outside air temperature	°C	30			

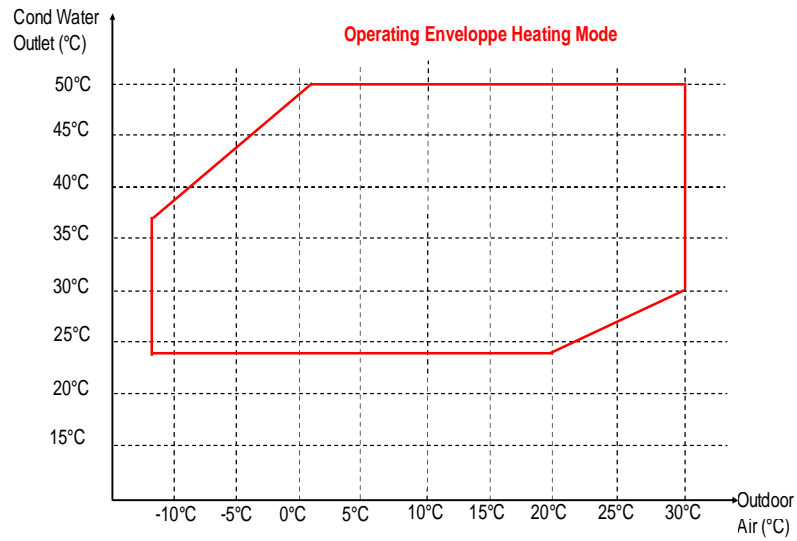

## ECOLOGIC - OPERATING LIMITS

WA STANDARD							
WA		150	200	230	270	300	370
Minimum outlet water temperature	°C	5					
Maximum inlet water temperature	°C	20					
Minimum difference water inlet/outlet	°C	3					
Maximum difference water inlet/outlet	°C	8					
Minimum outside air temperature	°C	6					
Minimum outside air temperature with low ambient kit	°C	-10					
Maximum outside air temperature :							
• Normal operation with CLIMATIC™ 50 12°C/7°C water + one compressor unloaded	°C	51	59	59	51	51	48
• Start-up with CLIMATIC™ 50 + Thermostatic expansion valve and ONE compressor unloaded	°C	49	46	46	48	48	45
• Start-up with CLIMATIC™ 50 + Electronic expansion valve and ONE compressor unloaded	°C	49	47	47	49	49	46

WA		200	230	270	300	370
<b>Operating limits for evaporator</b>						
Water	Test pressure	bar	10			
Refrigerant	Test pressure	bar	29			
Water	Max. operating pressure	bar	6			
Refrigerant	Max. operating pressure	bar	29			
Water	Minimum flow rate	m <sup>3</sup> /h	8°C ΔT			
Water	Maximum flow rate	m <sup>3</sup> /h	3°C ΔT			
<b>Operating limits for evaporator</b>						
Safety	Low pressure cut out	bar	0,7			
Safety	Interlocking of low pressure	bar	2,2			
Safety	High pressure cut out	bar	29			
Safety	High pressure reset	bar	20			

## Screw chiller - operating limits

### ALL UNITS

Size		402V	422VE	442V	452VE	502V
Max. outside air temperature (2)	°C	51	51	51	51	50,5
Size		552VE	602V	652VE	702V	752VE
Max. outside air temperature (2)	°C	50,5	50,5	50,5	50,5	50,5
Size		803V	853VE	953V	1003VE	1053V
Max. outside air temperature (2)	°C	50,5	50,5	50,5	50,5	49
Size		1153VE	1254V	1354VE	1404V	1504VE
Max. outside air temperature (2)	°C	49	50,5	50,5	49	49
Min. outlet water temperature	°C	5				
Max. inlet water temperature	°C	20				
Min. difference water inlet/outlet	°C	3				
Max. difference water inlet/outlet	°C	8				
Min. outside air temperature	°C	6				
Min. outside air temperature (1)	°C	-15				

<i>Operating limits for Evaporator</i>							
Water Test pressure	Bar	10					
Refrigerant Test pressure	Bar	26,5					
Water Max. operating pressure	Bar	6					
Refrigerant Max. operating pressure	Bar	26,5					
Water Min. flow	m3/h	8°C Δ T					
Size		442V	452VE	502V	552VE	602V	652VE
Water Max. flow	m3/h	89,3	89,3	153,5	153,5	153,53	153,5
Size		702V	752VE	803V	853VE	953V	1003VE
Water Max. flow	m3/h	153,5	153,5	153,5	153,5	180	180
Size		1053V	1153VE	1254V	1354VE	1404V	1504VE
Water Max. flow	m3/h	220	220	220	220	250	250
<i>Operating limits for Pressure gauge control</i>							
Safety Cut of low pressure	Bar	0,7					
Safety Interlocking of low pressure	Bar	2,2					
Safety Cut of high pressure	Bar	26,5					
Safety Interlocking of high pressure	Bar	20					

## RISK ANALYSIS AND HAZARDOUS SITUATIONS ACCORDING TO 97/23/CE DIRECTIVE

N°	Event	Effect	Risk	Actions to Eliminate the Risk	Information to minimise the Occurrence of a risk
1A	Violent Chocks, Static or Dynamic Loads applied	Appearance of cracks, distortions, possibility of rupture	Leaks, liquid or gas projections, Metal parts projections.	Only handling the units using the chassis and lifting rings if available.	Handling procedure shown in the IOM supplied with the unit.
2A	Unit not installed properly or leveled to the ground	Unusual stress in the frame leading to possible and strains vibrations and cracks	Leaks	Level the machine during commissioning. In the case where the unit is installed on anti-vibration mountings, all supporting points must be used and the block hardness must be selected according to the type of units being installed.	Indications on general mechanical drawings in the technical guide and the IOM supplied with the unit.
3A	Unsuited hydraulic or refrigeration pipe-work	Unusual stress on the pipe-work leading to possible and strains vibrations and cracks	Leaks	Proper support and fitting of the pipe-work on site.	Indications in the technical IOM supplied with the unit.
4A	Outdoor temperature below freezing	Strains, vibrations and cracks, pipe bursting.	Partial or complete destruction of the circuit, liquid/gas could be thrown out of the unit	Provide anti-frost protection (ei: Water treated with Glycol, or trace heaters along the pipe-work)	Indications in the technical IOM supplied with the unit.
5A	Circuits exposed to an unusual heat source.	Modification of the mechanical properties of certain materials with a risk or rupture or pipe bursting, leaks or cracks appearing.	Partial or complete destruction of the circuit, liquid/gas could be thrown out of the unit	Recommended minimum and maximum outdoor temperature -20°C to 50°C during operation. -30°C to 65°C during storage Do not expose any part of the machine to a naked flame	Indications of the Min and Max outdoor temperature on the unit nameplate
6A	Unusual increase in the temperature of the Chilled water return to the evaporator or the hot return water to the condenser	Increase of the refrigerant pressure in the heat exchanger with a risk of exceeding the working pressure leading to possible strains, vibrations, cracks and pipe or vessel bursting.	Partial or complete destruction of the circuit, liquid/gas/metal parts could be thrown out of the unit	Maximum chilled water return temperature: 45°C Maximum hot return water temperature: 50°C Install a temperature limitation device	Indications in the technical IOM supplied with the unit.
7A	Possibility of a unit being hit by lightning	Extreme heat, explosion, cracks.	Partial or complete destruction of the circuit, liquid/gas/metal parts could be thrown out of the unit	Provide an appropriate protection against lightning.	Indications in the technical IOM supplied

N°	Event	Effect	Risk	Actions to Eliminate the Risk	Information to minimise the Occurrence of a risk
8A	Unit exposed to extremely corrosive materials.	Modification of the mechanical and chemical properties of certain materials with a risk or corrosion rupture, pipe bursting, leaks and cracks.	Partial or complete destruction of the circuit, liquid/gas/metal parts could be thrown out of the unit	Protect the units against these types of products	Indications in the technical IOM supplied
9A	Unit exposed to explosive materials.	Risk of explosion or pipe bursting.	Partial or complete destruction of the circuit, liquid/gas/metal parts could be thrown out of the unit	Protect the units against these types of products	Indications in the technical IOM supplied
10A	Inappropriate Heat Transfer Fluid	Corrosion, excessive heat	Partial or complete destruction of the circuit. Leaks	Usual fluids are Water or Water with Glycol.	Indications in the technical IOM supplied
11A	Inappropriate refrigerant fluid in the circuit	Corrosion, excessive heat, combustion or explosion	Partial or complete destruction of the circuit, liquid/gas/metal parts could be thrown out of the unit	Only use the fluid specified on the unit's nameplate.	Indications of the refrigerant fluid on the unit nameplate
12A	Inappropriate oil in the compressor	Corrosion, excessive heat,	Partial or complete destruction of the circuit. Leaks	Authorized oils: Refer to the compressor nameplate or the documentation.	Indication on the compressor nameplate or the manufacturer documentation.
13A	Working on a part under pressure	Risk of explosion or part bursting away from the machine.	Liquid/gas/metal parts could be thrown out of the unit	Isolate the section of the circuit to be worked on and recover the refrigerant before any work. Always wear protection goggles and gloves.	Indications in the technical IOM supplied
14A	Brazing or un-brazing parts from the circuit	Strains, cracks, pipe bursting	Partial or complete destruction of the circuit, liquid/gas/metal parts could be thrown out of the unit	Parts to be brazed using best engineering practices. Use brazing materials approved by Lennox. Ensure the circuit is leak free before refilling with refrigerant.	Indications in the technical IOM supplied
15A	Unit exposed to inductive interferences	Corrosions, cracks	leaks	Ensure the unit is earthed properly	Indications in the technical IOM supplied
16A	Unit exposed to internal or external vibrations	Strains, cracks, explosions	Partial or complete destruction of the circuit, liquid/gas/metal parts could be thrown out of the unit	Inspect the unit regularly	Indications in the technical IOM supplied

# NEOSYS - REFRIGERATION CIRCUITS

## NAC Refrigeration Circuit

All NAC units C1 & C2

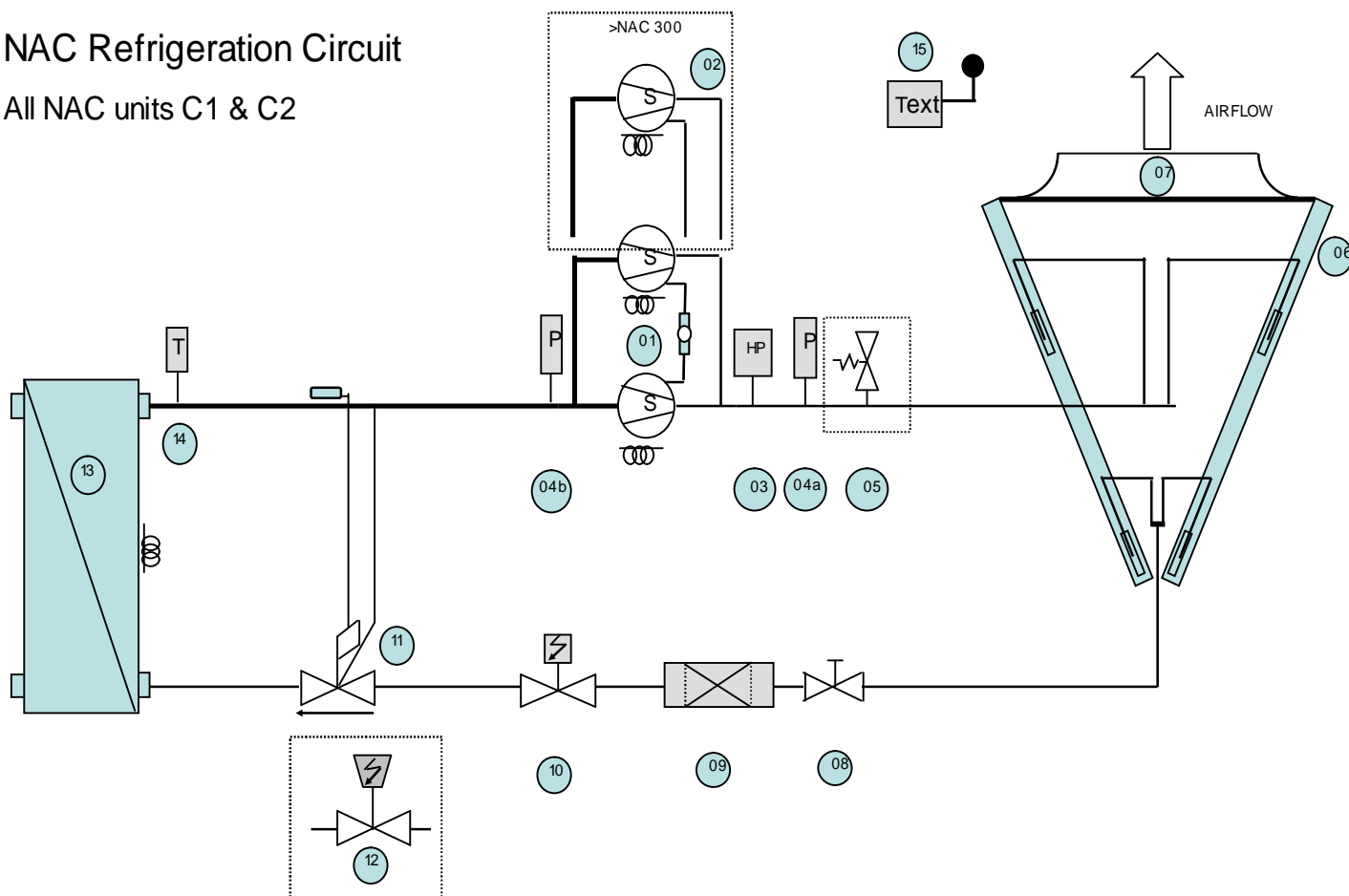

01	1st & 2nd Scroll Compressors	05	Pressure relief Valve	11	Thermostatic Expansion Valve
02	Third Scroll Compressor on size above 300kW	06	Air Cooled Condenser	12	Electronic Expansion Valve
03	High Pressure Sw itch	07	Fan Motor	13	Evaporator Heat Exchanger
04a 04b	Pressure transducers HP & BP	08	Manual Isolating Valve	14	Suction Temperature Sensor
		09	Cartridge Filter Drier	15	External Temperature Sensor
		10	Solenoid valve		Heating resistance (OPTION)



# NEOSYS - REFRIGERATION CIRCUITS

## NAH Refrigeration Circuit

All NAH units C1 & C2

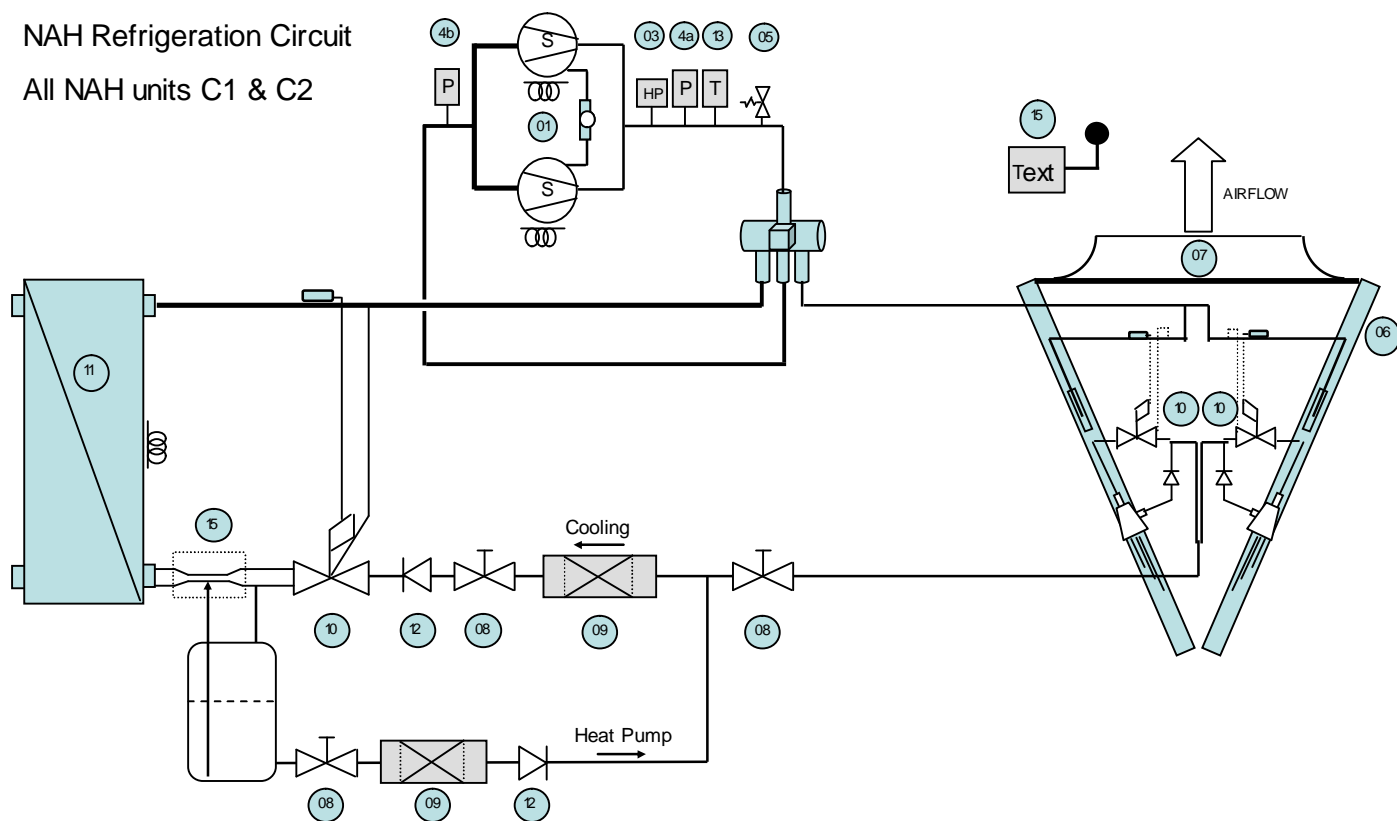

01	1st & 2nd Scroll Compressors	06	Air Cooled Heat Exchanger	11	Plate Heat Exchanger
03	High Pressure Switch	07	Fan Motor	12	Non Return valve
04a 04b	Pressure transducers HP & BP	08	Manual Isolating Valve	13	Discharge Temperature Sensor
05	Pressure relief Valve	09	Cartridge Filter Drier	14	External Temperature Sensor
⊞	Heating resistance (OPTION)	10	Thermostatic Expansion Valve	15	Liquid Suction Venturi
				16	Liquid Receiver

# ECOLOGIC - REFRIGERATION CIRCUIT REFRIGERANT DRAWING

WA STD

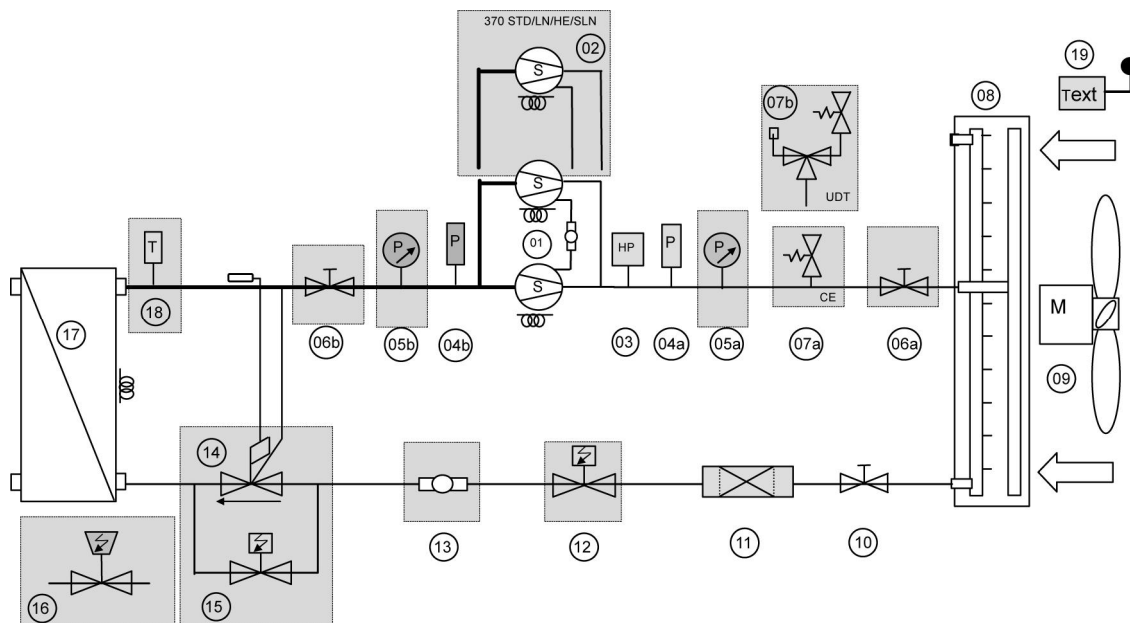

## REFRIGERATION CIRCUIT COMPONENTS

01	1st & 2nd scroll compressors	08	Air cooled condenser	15	Expansion valve bypass for low ambient operation	
02	3rd scroll compressor on size 370 STD/LN/HE & SLN	09	Fan motor	16	Electronic expansion valve	
03	High pressure switch	10	Manual isolating valve	17	Evaporator heat exchanger	
04a	04b	Pressure transducers HP & BP	11	Filter drier	18	Suction temperature sensor
05a	05b	Low and High pressure manometer	12	Solenoid valve	19	External temperature sensor
06a	06b	Suction and discharge isolation valves	13	Sight glass		Heating resistance (option)
07a	07b	Safety valve CE or UDT	14	Thermostatic expansion valve		

VARIANTS			EXPANSION DEVICE			OPTIONS		
<b>BASIC UNIT</b>	Size 370 STD/LN/HE/SLN	WA unit CE or UDT	Thermostatic expansion valve	Thermostatic expansion valve + low ambient	Electronic expansion valve	HP/LP pressure gauges	Suction and discharge isolating valve	Sight glass
01/03/04a/04b/08/09/10/11/17/19	Add 02	07a or 07b	Add 14 & 12	Add 14, 12 & 15	Add 16 & 18	Add 05a & 05b	Add 06a & 06b	Add 13

# RA - REFRIGERATION CIRCUIT REFRIGERANT DRAWING

RA STD

C1 & C2

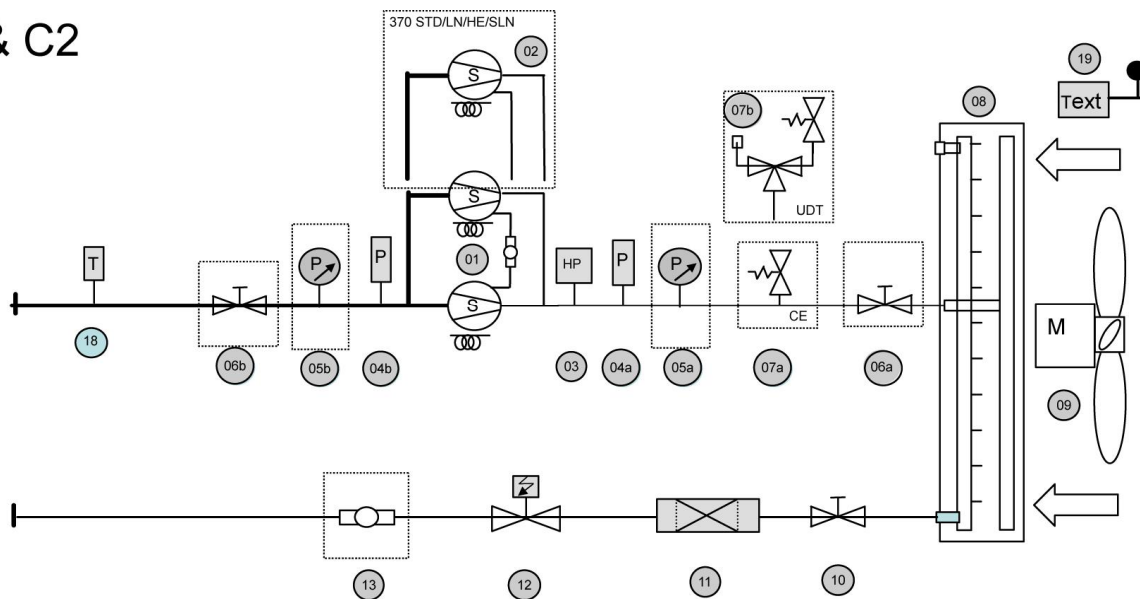

## REFRIGERATION CIRCUIT COMPONENTS

<b>01</b>	1st & 2nd scroll compressors	<b>07a</b> <b>07b</b>	Safety valve CE or UDT	<b>12</b>	Solenoid valve
<b>02</b>	3rd scroll compressor on size 370 STD/LN/HE & SLN	<b>08</b>	Air cooled condenser	<b>13</b>	Sight glass
<b>03</b>	High pressure switch	<b>09</b>	Fan motor	<b>18</b>	Suction temperature sensor
<b>04a</b> <b>04b</b>	Pressure transducers HP & BP	<b>10</b>	Manual isolating valve	<b>19</b>	External temperature sensor
<b>05a</b> <b>05b</b>	Low and High pressure manometer	<b>11</b>	Filter drier		Heating resistance (option)
<b>06a</b> <b>06b</b>	Suction and discharge isolation valves				

VARIANTS			OPTIONS		
<b>BASIC UNIT</b>	Size 370 STD/LN/HE/SLN	WA unit CE or UDT	HP/LP pressure gauges	Suction and discharge isolating valve	Sight glass
01/03/04a/04b/08/09/10/11/12/18/19	Add 02	07a or 07b	Add 05a & 05b	Add 06a & 06b	Add 13

# CERTIFICATES



## Certification

Attribuée à

### LGL FRANCE

Zone Industrielle Les Meurières  
69780 MIONS

FRANCE

BVQI certifie que le Système de Management de la Qualité de l'Entreprise susmentionnée a été évalué et jugé conforme aux exigences de la norme :

STANDARD

**NF EN ISO 9001 : 2000**

DOMAINE D'ACTIVITÉ

**CONCEPTION, FABRICATION ET CESSION INTERNE DE BIENS D'ÉQUIPEMENT DESTINÉS AU CONDITIONNEMENT D'AIR ET À LA RÉFRIGÉRATION.**

**DESIGN, MANUFACTURING AND INTERNAL TRANSFER OF EQUIPMENT GOODS DEDICATED TO AIR CONDITIONING AND REFRIGERATION.**

Date de certification originale : **22 avril 2005**

Sous réserve du fonctionnement continu et satisfaisant du système qualité de l'entreprise, ce certificat est valable jusqu'au : **31 mars 2008**

Pour vérifier la validité du certificat, appelez le : 04 78 66 82 60

Tout éclaircissement sur cette certification peut-être obtenu auprès de l'entreprise certifiée.

Numéro de Certificat : 172696    Date : 22 avril 2005  
Numéro d'Affaire : 1411599

Jean-Claude BOURGEOIS  
Directeur Général



BUREAU EN CHARGE

BUREAU EMETTEUR

BVQI France S.A  
60 avenue du Général de Gaulle  
92046 Paris-la-Defense Cedex  
France

BVQI France - Dir. Contrats  
1 rue des Vergers - Sit.c 4A  
69760 Limonest  
France



Bureau Veritas S.A. is a Notified

Body under the number 0062



**BUREAU  
VERITAS**

**ATTESTATION D'APPROBATION DE SYSTEME DE QUALITE (module H1)**  
**CERTIFICATE OF QUALITY SYSTEM APPROVAL (module H1)**  
**N° CE-PED-H1- LEN001-02-FRA**

BUREAU VERITAS S.A., agissant dans le cadre de sa notification (numéro d'organisme notifié 0062), atteste que le système de qualité appliqué par le fabricant pour la conception, la fabrication, l'inspection finale et les essais des équipements sous pression identifiés ci-après, a été examiné selon les prescriptions du module H1 de l'annexe III de la directive "Equipements sous pression" N° 97/23/CE et est conforme aux dispositions correspondantes de la directive.

*BUREAU VERITAS S.A., acting within the scope of its notification (notified body number 0062), attests that the quality system operated by the manufacturer for design, manufacture, final inspection and testing of the pressure equipment identified hereunder has been examined against the provisions of annex III, module H1, of the Pressure Equipment directive n° 97/23/EC, and found to satisfy the provisions of the directive which apply to it.*

Fabricant (nom) / *Manufacturer (name):* **LENNOX – France Usine de MIONS**  
 Adresse / *Address:* **Z.I. Les Meurières – BP 71 – F. 69780 - MIONS**  
 Marque commerciale / *Trade mark:* **LENNOX**  
 Description des équipements: **Ensemble sous pression**  
*Equipment description:*

Identification des équipements concernés (*liste en annexe le cas échéant*) : **Suivant liste en annexe**  
*Identification of equipment concerned (list attached where necessary):*

Numéro(s) d'attestation(s) d'examen CE de la conception émise(s), dans le cadre de l'application du module H1, par BUREAU VERITAS S.A. (organisme notifié n° 0062), concernée(s) par l'approbation du système de qualité:  
*Number(s) of the EC design-examination certificate(s) issued under the scope of module H1, by BUREAU VERITAS S.A. (notified body nr 0062), concerned by the approval of the quality system:*

Cette attestation est valable jusqu'au .... **02/09/2005**  
*This certificate is valid until....*

Le maintien de l'approbation est soumis à la réalisation par le Bureau Veritas des audits, essais et vérifications selon le contrat signé par le fabricant et le Bureau Veritas.  
*The approval is conditional upon the surveillance audits, tests and verifications to be carried out by Bureau Veritas, as per the provisions stated in the agreement signed by both the manufacturer and Bureau Veritas.*

Cette attestation est présumée nulle et le fabricant supportera seul les conséquences de son utilisation, si les assurances - données par le fabricant lors de la demande d'intervention - en matière (a) d'application de son système qualité approuvé, (b) de conformité de son équipement à son approbation CE de la conception et (c) d'inspection et d'essais des produits finis se révèlent inexactes et, de manière générale, si le fabricant ne respecte pas l'une ou l'autre des obligations mises à sa charge par la directive n° 97/23/CE du 29 mai 1997 telle que transposée dans le(s) droit(s) national(aux) applicable(s).  
*This certificate shall be deemed to be void and the manufacturer shall alone bear any consequences pursuant to its use, where the manufacturer fails to comply with his undertakings as per the agreement in respect of (a) implementation of the approved quality system, (b) conformity of the equipment with the EC design-approval conditions and (c) inspection and tests on the final product, and generally where the manufacturer fails in particular to comply with any of his obligations under directive nr 97/23/EC of 29 may 1997 as transposed in the applicable law(s).*

Etébli à / <i>Made at</i>	Le / <i>On</i>	Signé par / <i>Signed by</i>	Signature / <i>Signature</i>
LYON/DARDILLY	02 SEPTEMBRE 2002	P.BERIOU	
Code d'enregistrement / <i>Registration code:</i> <b>2002/3948/P</b>			

La présente attestation est soumise aux Conditions Générales de Service de Bureau Veritas jointes à la demande d'intervention signée par le demandeur.  
*This certificate is subject to the terms of Bureau Veritas General Conditions of Service attached to the agreement signed by the applicant.*

ADV/DECONF/M001 - 1



**Site industriel de Mions**  
 ZI «Les Meurières» - BP 71  
 69780 Mions - France  
 Téléphone : +33 (0)4 72 23 20 20  
 Fax : +33 (0)4 72 23 04 56

## DECLARATION OF CONFORMITY CE

The Undersigned Company certifies under its responsibility that the equipment under pressure identified below is in conformity with the requirements of the directive that are applicable, **EQUIPMENT UNDER PRESSURE N° 97/23/CE**.

### Description of Equipment Under Pressure and the Procedure of Evaluation to be in Conformity

<b>Type of Machine</b>	
Serial Number	
Year of Manufacture	
Catégorie de la DESP	<b>II</b>
Procedure of Evaluation	Module H1 Attestation N°
Certificat d'examen CE de la conception	Module H1D Attestation N°

### Description of Components Under Pressure

Type of Component	Category of Risk
<b>COMPRESSEUR SZ 300</b>	<b>II</b>
<b>EVAPORATOR</b>	<b>I</b>
<b>FILTER DRYER VS489</b>	<b>I</b>
<b>EXPENSION VALVE TRE 80</b>	<b>ART 3-3</b>
<b>TUBE</b>	<b>I</b>
<b>PRESSURE SWITCH P100</b>	<b>II</b>
<b>SAFETY VALVE 450PSI</b>	<b>II</b>

### Name and Address of the Organisation Auditing the Quality Assurance System (NF EN ISO 9001)

AFAQ  
 F - 92224 Bagneux Cedex FRANCE  
 N° d'agrément QUAL/1993/1009

### Name and Address of the Organisation Auditing our Conformity to the Directive of Equipment Under Pressure (DI-97/23/CE)

BUREAU VERITAS  
 F - 92077 Paris La Défense  
 N° d'agrément CE 0062

### References to Standards that are Applicable

- NF-EN 60204-1 : Safety of machinery. Electrical equipment of machines.

### References to Other Standards :

- Directive 98/37/EC : Relating to machinery
- Directive 93/68/EEC : Relating to electrical equipment designed for use within certain voltage limits
- Directive 89/336/EEC : Relating to electromagnetic compatibility

### Personal Liability for the Manufacture :

Name : Fabrice EXCOFFIER

Function: Customer Service Manager

Date: 11/01/2005

Signature:

LENNOX France, Division climatisation de LGL France

Siège social : LGL France - ZI les Meurières - 69780 Mions - France  
 Société Anonyme au capital de 37 029 000€ - RCS LYON B 309 528 115 - N° IDENTIFICATION TVA FR 59 309 528 115 - APE 292 F

## START-UP AND MAINTENANCE LOGBOOK

### INSTALLATION CHECK-UP

This check list should be filled in before the start-up with the contractor to make sure that unit installation takes place according to appropriate industry practices.

**WARNING** : Refer to Safety recommendation §2.1 prior to any work on the unit.

DATE:

TECHNICIAN:

<b>FIELD NAME:</b>
<b>CUSTOMER :</b>
<b>Unit exact designation:</b>
<b>Affair n° :</b>
<b>Serial n°:</b>
<b>Customer designation:</b>
<b>Contractors contact name and telephone:</b>
<b>Local contact name and telephone:</b>

**SAFETY ACCES TO THE INSTALLATION**

Safety scale :

Footbridge around unit:

Clearance conform to regulation:

**Dangerous working conditions :**

YES	NO

### CONFIRMATION OF INSTALLER DATA GIVEN PRIOR TO COMMISSIONING

	YES	NO
Compressors crankcase heater ON 24 hours before start-up		
Connection and balancing of the aeraulic network (centrifugal fans)		
Connection, cleaning, rinsing and purging of the hydraulic network		
Water circuit protection against freezing		
Cooling load available, minimum 50 %		
Presence of mesh filters at the entry of the exchangers		
Connection of the remote elements with recommended cable		
Presence of the general power supply (correctly dimensioned)		
Presence of the 220V power supply if any		
Presence of correct water flow		
Connection of controls and alarms		
Vacuum and first refrigerant charge done for split unit		
<b>Safe access to components</b>		

The information of pre startup is in conformity:	YES	NO
--	-----	----

### • UNIT INSTALLATION

	YES	NO
CLEARANCE AROUND UNIT IN CONFORMITY		
CORRECT CONDENSORS VENTILATION		
UNIIT LEVELLED		
VIBRATION ISOLATION MOUNTED AND PROPERLY DIMENSIONED		
VIBRATION ISOLATORS ON PIPING CONNECTION		
CORRECT EARTHING OF THE UNIT		
EARTH CONTINUITY ON PIPING		

### • HYDRAULIC NETWORK

	YES	NO
GLYCOL PROTECTION IN CONFORMITY		
PRIMARY LOOP		
SECONDARY LOOP		
WATER TANK		
WATER PUMP AT THE EVAPORATOR ENTRY		
WATER FLOW SWITCH AT THE EVAPORATOR OUTLET		
PRESSOSTATIC FLOW SWITCH		
WATER PUMP AT THE CONDENSER ENTRY		
CONTROL OF THE REMAOTE FAULTY WATER PUMPS		
FLOW SWITCH CUT OFF CONTROL		
MINIMUM CHILLED WATER NETWORK VOLUME GIVEN BY THE CUSTOMER		m <sup>3</sup>
MINIMUM HOT WATER NETWORK VOLUME GIVEN BY THE CUSTOMER		m <sup>3</sup>

### • CLIMATIC SET POINTS

CHILLED WATER SET POINT	°C
HOT WATER SET POINT	°C
ANTIFREEZE SET POINT (WATER)	°C
ANTIFREEZE SET POINT (REFRIGERANT)	°C
COMPRESSORS REACTIVITY	
FANS REACTIVITY	
GLYCOL PERCENTAGE	%
BIOS VERSION	
PROGRAM VERSION	



# START-UP CHECK SHEET

Unit type				Technician name																							
Construction year				Start-up date																							
<b>THERMAL DATA</b>																											
Evaporator I / O temp.		/ °C		/ °C		/ °C																					
Condenser I / O temp		/ °C		/ °C		/ °C																					
Ambient air temp		°C		°C		°C																					
<b>FRIGORIFIC DATA</b>																											
Cooling capacity: Kw		<b>CIRCUIT 1</b>		<b>CIRCUIT 2</b>		<b>CIRCUIT 3</b>		<b>CIRCUIT 4</b>																			
Operating mode		%		%		%		%																			
Low pressure		b		b		b		b																			
Evaporating temp.		°C		°C		°C		°C																			
Suction temp.		°C		°C		°C		°C																			
High pressure		b		b		b		b																			
Condensing temp.		°C		°C		°C		°C																			
Liquid temp.		°C		°C		°C		°C																			
Discharge temp.		°C		°C		°C		°C																			
Oil level																											
Refrigerant type:.....charge		Kg		Kg		Kg		Kg																			
LP safety cut		b		b		b		b																			
HP safety cut		b		b		b		b																			
<b>ELECTRICAL DATA</b>																											
<b>Power supply</b>		.....V		<b>CIRCUIT 1</b>			<b>CIRCUIT 2</b>			<b>CIRCUIT 3</b>		<b>CIRCUIT 4</b>															
				C1 C2 C3			C1 C2 C3																				
<b>Compressors</b>	<b>KM1</b>	L1 (A)																									
		L2 (A)																									
		L3 (A)																									
	<b>KM2</b>	L4 (A)																									
		L5 (A)																									
		L6 (A)																									
<b>Evaporator pumps</b>	L1 (A)																										
	L2 (A)																										
	L3 (A)																										
<b>Condenser pumps</b>	L1 (A)																										
	L2 (A)																										
	L3 (A)																										
<b>Nominal current (A)</b>				V1		V2		V3		V4		V5		V6		V7		V8		V9		V10		V11		V12	
<b>Condensers fans</b>	V1 à V12	L1 (A)																									
		L2 (A)																									
		L3 (A)																									
	V13 à V24	L1 (A)																									
		L2 (A)																									
		L3 (A)																									
				V13		V14		V15		V16		V17		V18		V19		V20		V21		V22		V23		V24	
<b>Water Electric heaters</b>	L1 (A)																										
	L2 (A)																										
	L3 (A)																										
<i>Theoric Δp evaporator:</i>						Kpa		<i>Evaporator Measured Δp:</i>																			
<i>Theoric Δp condenser::</i>						Kpa		<i>Condenser measured Δp:</i>																			
Evaporator pumps references														Q:				H:									
Condenser pumps references														Q:				H:									



## MAINTENANCE LOGBOOK

MAINTENANCE visit n° 1 (500H / 1000H)			Date			
	Y / N	Value	Comments			
Unit general control (corrosion, damages...)						
Exchanger cleaning						
Leak test done						
Oil acidity test carried						
Replacement of filter drier cartridge						
Water filters cleans						
Evaporator pressure drop		Kpa				
Water condenser pressure drop		Kpa				
Glycol concentration level		%				
Unit operating parameters checked and in conformity						
Fans currents level checked and in conformity						
Compressors data	CP1	CP2	CP3	CP4	CP5	CP6
Operating hours						
Current at 100% load						
Comments et remarks:						
			TECHNICIAN		CLIENT	
			Name		Name	
			Signature:		Signature:	

MAINTENANCE visit n° 2			Date			
	Y / N	Value	Comments			
Unit general control (corrosion, damages...)						
Exchanger cleaning						
Leak test done						
Oil acidity test carried						
Replacement of filter drier cartridge						
Water filters cleans						
Evaporator pressure drop		Kpa				
Water condenser pressure drop		Kpa				
Glycol concentration level		%				
Unit operating parameters checked and in conformity						
Fans currents level checked and in conformity						
Compressors data	CP1	CP2	CP3	CP4	CP5	CP6
Operating hours						
Current at 100% load						
Comments et remarks:						
			TECHNICIAN		CLIENT	
			Name		Name	
			Signature:		Signature:	

## MAINTENANCE LOGBOOK

MAINTENANCE visit n° 3			Date			
	Y / N	Value	Comments			
Unit general control (corrosion, damages...)						
Exchanger cleaning						
Leak test done						
Oil acidity test carried						
Replacement of filter drier cartridge						
Water filters cleans						
Evaporator pressure drop		Kpa				
Water condenser pressure drop		Kpa				
Glycol concentration level		%				
Unit operating parameters checked and in conformity						
Fans currents level checked and in conformity						
Compressors data	CP1	CP2	CP3	CP4	CP5	CP6
Operating hours						
Current at 100% load						
Comments et remarks:						
			TECHNICIAN		CLIENT	
			Name		Name	
			Signature:		Signature:	

MAINTENANCE visit n° 4			Date			
	Y / N	Value	Comments			
Unit general control (corrosion, damages...)						
Exchanger cleaning						
Leak test done						
Oil acidity test carried						
Replacement of filter drier cartridge						
Water filters cleans						
Evaporator pressure drop		Kpa				
Water condenser pressure drop		Kpa				
Glycol concentration level		%				
Unit operating parameters checked and in conformity						
Fans currents level checked and in conformity						
Compressors data	CP1	CP2	CP3	CP4	CP5	CP6
Operating hours						
Current at 100% load						
Comments et remarks:						
			TECHNICIAN		CLIENT	
			Name		Name	
			Signature:		Signature:	

## MAINTENANCE LOGBOOK

MAINTENANCE visit n° 5			Date			
	Y / N	Value	Comments			
Unit general control (corrosion, damages...)						
Exchanger cleaning						
Leak test done						
Oil acidity test carried						
Replacement of filter drier cartridge						
Water filters cleans						
Evaporator pressure drop		Kpa				
Water condenser pressure drop		Kpa				
Glycol concentration level		%				
Unit operating parameters checked and in conformity						
Fans currents level checked and in conformity						
Compressors data	CP1	CP2	CP3	CP4	CP5	CP6
Operating hours						
Current at 100% load						
Comments et remarks:						
			TECHNICIAN		CLIENT	
			Name		Name	
			Signature:		Signature:	

MAINTENANCE visit n° 6			Date			
	Y / N	Value	Comments			
Unit general control (corrosion, damages...)						
Exchanger cleaning						
Leak test done						
Oil acidity test carried						
Replacement of filter drier cartridge						
Water filters cleans						
Evaporator pressure drop		Kpa				
Water condenser pressure drop		Kpa				
Glycol concentration level		%				
Unit operating parameters checked and in conformity						
Fans currents level checked and in conformity						
Compressors data	CP1	CP2	CP3	CP4	CP5	CP6
Operating hours						
Current at 100% load						
Comments et remarks:						
			TECHNICIAN		CLIENT	
			Name		Name	
			Signature:		Signature:	

## MAINTENANCE LOGBOOK

MAINTENANCE visit n° 7			Date			
	Y / N	Value	Comments			
Unit general control (corrosion, damages...)						
Exchanger cleaning						
Leak test done						
Oil acidity test carried						
Replacement of filter drier cartridge						
Water filters cleans						
Evaporator pressure drop		Kpa				
Water condenser pressure drop		Kpa				
Glycol concentration level		%				
Unit operating parameters checked and in conformity						
Fans currents level checked and in conformity						
Compressors data	CP1	CP2	CP3	CP4	CP5	CP6
Operating hours						
Current at 100% load						
Comments et remarks:						
			TECHNICIAN		CLIENT	
			Name		Name	
			Signature:		Signature:	

MAINTENANCE visit n° 8			Date			
	Y / N	Value	Comments			
Unit general control (corrosion, damages...)						
Exchanger cleaning						
Leak test done						
Oil acidity test carried						
Replacement of filter drier cartridge						
Water filters cleans						
Evaporator pressure drop		Kpa				
Water condenser pressure drop		Kpa				
Glycol concentration level		%				
Unit operating parameters checked and in conformity						
Fans currents level checked and in conformity						
Compressors data	CP1	CP2	CP3	CP4	CP5	CP6
Operating hours						
Current at 100% load						
Comments et remarks:						
			TECHNICIAN		CLIENT	
			Name		Name	
			Signature:		Signature:	

## MAINTENANCE LOGBOOK

MAINTENANCE visit n° 9			Date			
	Y / N	Value	Comments			
Unit general control (corrosion, damages...)						
Exchanger cleaning						
Leak test done						
Oil acidity test carried						
Replacement of filter drier cartridge						
Water filters cleans						
Evaporator pressure drop		Kpa				
Water condenser pressure drop		Kpa				
Glycol concentration level		%				
Unit operating parameters checked and in conformity						
Fans currents level checked and in conformity						
Compressors data	CP1	CP2	CP3	CP4	CP5	CP6
Operating hours						
Current at 100% load						
Comments et remarks:						
			TECHNICIAN		CLIENT	
			Name		Name	
			Signature:		Signature:	

MAINTENANCE visit n° 10			Date			
	Y / N	Value	Comments			
Unit general control (corrosion, damages...)						
Exchanger cleaning						
Leak test done						
Oil acidity test carried						
Replacement of filter drier cartridge						
Water filters cleans						
Evaporator pressure drop		Kpa				
Water condenser pressure drop		Kpa				
Glycol concentration level		%				
Unit operating parameters checked and in conformity						
Fans currents level checked and in conformity						
Compressors data	CP1	CP2	CP3	CP4	CP5	CP6
Operating hours						
Current at 100% load						
Comments et remarks:						
			TECHNICIAN		CLIENT	
			Name		Name	
			Signature:		Signature:	

## MAINTENANCE LOGBOOK

MAINTENANCE visit n° 11			Date			
	Y / N	Value	Comments			
Unit general control (corrosion, damages...)						
Exchanger cleaning						
Leak test done						
Oil acidity test carried						
Replacement of filter drier cartridge						
Water filters cleans						
Evaporator pressure drop		Kpa				
Water condenser pressure drop		Kpa				
Glycol concentration level		%				
Unit operating parameters checked and in conformity						
Fans currents level checked and in conformity						
Compressors data	CP1	CP2	CP3	CP4	CP5	CP6
Operating hours						
Current at 100% load						
Comments et remarks:						
			TECHNICIAN		CLIENT	
			Name		Name	
			Signature:		Signature:	

MAINTENANCE visit n° 12			Date			
	Y / N	Value	Comments			
Unit general control (corrosion, damages...)						
Exchanger cleaning						
Leak test done						
Oil acidity test carried						
Replacement of filter drier cartridge						
Water filters cleans						
Evaporator pressure drop		Kpa				
Water condenser pressure drop		Kpa				
Glycol concentration level		%				
Unit operating parameters checked and in conformity						
Fans currents level checked and in conformity						
Compressors data	CP1	CP2	CP3	CP4	CP5	CP6
Operating hours						
Current at 100% load						
Comments et remarks:						
			TECHNICIAN		CLIENT	
			Name		Name	
			Signature:		Signature:	



## MAINTENANCE LOGBOOK

MAINTENANCE visit n° 13			Date			
	Y / N	Value	Comments			
Unit general control (corrosion, damages...)						
Exchanger cleaning						
Leak test done						
Oil acidity test carried						
Replacement of filter drier cartridge						
Water filters cleans						
Evaporator pressure drop		Kpa				
Water condenser pressure drop		Kpa				
Glycol concentration level		%				
Unit operating parameters checked and in conformity						
Fans currents level checked and in conformity						
Compressors data	CP1	CP2	CP3	CP4	CP5	CP6
Operating hours						
Current at 100% load						
Comments et remarks:						
			TECHNICIAN		CLIENT	
			Name		Name	
			Signature:		Signature:	

MAINTENANCE visit n° 14			Date			
	Y / N	Value	Comments			
Unit general control (corrosion, damages...)						
Exchanger cleaning						
Leak test done						
Oil acidity test carried						
Replacement of filter drier cartridge						
Water filters cleans						
Evaporator pressure drop		Kpa				
Water condenser pressure drop		Kpa				
Glycol concentration level		%				
Unit operating parameters checked and in conformity						
Fans currents level checked and in conformity						
Compressors data	CP1	CP2	CP3	CP4	CP5	CP6
Operating hours						
Current at 100% load						
Comments et remarks:						
			TECHNICIAN		CLIENT	
			Name		Name	
			Signature:		Signature:	

## MAINTENANCE LOGBOOK

MAINTENANCE visit n° 15			Date			
	Y / N	Value	Comments			
Unit general control (corrosion, damages...)						
Exchanger cleaning						
Leak test done						
Oil acidity test carried						
Replacement of filter drier cartridge						
Water filters cleans						
Evaporator pressure drop		Kpa				
Water condenser pressure drop		Kpa				
Glycol concentration level		%				
Unit operating parameters checked and in conformity						
Fans currents level checked and in conformity						
Compressors data	CP1	CP2	CP3	CP4	CP5	CP6
Operating hours						
Current at 100% load						
Comments et remarks:						
			TECHNICIAN		CLIENT	
			Name		Name	
			Signature:		Signature:	

MAINTENANCE visit n° 16			Date			
	Y / N	Value	Comments			
Unit general control (corrosion, damages...)						
Exchanger cleaning						
Leak test done						
Oil acidity test carried						
Replacement of filter drier cartridge						
Water filters cleans						
Evaporator pressure drop		Kpa				
Water condenser pressure drop		Kpa				
Glycol concentration level		%				
Unit operating parameters checked and in conformity						
Fans currents level checked and in conformity						
Compressors data	CP1	CP2	CP3	CP4	CP5	CP6
Operating hours						
Current at 100% load						
Comments et remarks:						
			TECHNICIAN		CLIENT	
			Name		Name	
			Signature:		Signature:	

## MAINTENANCE LOGBOOK

MAINTENANCE visit n° 17			Date			
	Y / N	Value	Comments			
Unit general control (corrosion, damages...)						
Exchanger cleaning						
Leak test done						
Oil acidity test carried						
Replacement of filter drier cartridge						
Water filters cleans						
Evaporator pressure drop		Kpa				
Water condenser pressure drop		Kpa				
Glycol concentration level		%				
Unit operating parameters checked and in conformity						
Fans currents level checked and in conformity						
Compressors data	CP1	CP2	CP3	CP4	CP5	CP6
Operating hours						
Current at 100% load						
Comments et remarks:						
			TECHNICIAN		CLIENT	
			Name		Name	
			Signature:		Signature:	

MAINTENANCE visit n° 18			Date			
	Y / N	Value	Comments			
Unit general control (corrosion, damages...)						
Exchanger cleaning						
Leak test done						
Oil acidity test carried						
Replacement of filter drier cartridge						
Water filters cleans						
Evaporator pressure drop		Kpa				
Water condenser pressure drop		Kpa				
Glycol concentration level		%				
Unit operating parameters checked and in conformity						
Fans currents level checked and in conformity						
Compressors data	CP1	CP2	CP3	CP4	CP5	CP6
Operating hours						
Current at 100% load						
Comments et remarks:						
			TECHNICIAN		CLIENT	
			Name		Name	
			Signature:		Signature:	

## MAINTENANCE LOGBOOK

MAINTENANCE visit n° 19			Date			
	Y / N	Value	Comments			
Unit general control (corrosion, damages...)						
Exchanger cleaning						
Leak test done						
Oil acidity test carried						
Replacement of filter drier cartridge						
Water filters cleans						
Evaporator pressure drop		Kpa				
Water condenser pressure drop		Kpa				
Glycol concentration level		%				
Unit operating parameters checked and in conformity						
Fans currents level checked and in conformity						
Compressors data	CP1	CP2	CP3	CP4	CP5	CP6
Operating hours						
Current at 100% load						
Comments et remarks:						
			TECHNICIAN		CLIENT	
			Name		Name	
			Signature:		Signature:	

MAINTENANCE visit n° 20			Date			
	Y / N	Value	Comments			
Unit general control (corrosion, damages...)						
Exchanger cleaning						
Leak test done						
Oil acidity test carried						
Replacement of filter drier cartridge						
Water filters cleans						
Evaporator pressure drop		Kpa				
Water condenser pressure drop		Kpa				
Glycol concentration level		%				
Unit operating parameters checked and in conformity						
Fans currents level checked and in conformity						
Compressors data	CP1	CP2	CP3	CP4	CP5	CP6
Operating hours						
Current at 100% load						
Comments et remarks:						
			TECHNICIAN		CLIENT	
			Name		Name	
			Signature:		Signature:	







[www.lennox europe.com](http://www.lennox europe.com)

**BELGIUM, LUXEMBOURG**  
[www.lennoxbelgium.com](http://www.lennoxbelgium.com)

**CZECH REPUBLIC**  
[www.lennox czech.com](http://www.lennox czech.com)

**FRANCE**  
[www.lennoxfrance.com](http://www.lennoxfrance.com)

**GERMANY**  
[www.lennox deutschland.com](http://www.lennox deutschland.com)

**NETHERLANDS**  
[www.lennox nederland.com](http://www.lennox nederland.com)

**POLAND**  
[www.lennox polska.com](http://www.lennox polska.com)

**PORTUGAL**  
[www.lennoxportugal.com](http://www.lennoxportugal.com)

**RUSSIA**  
[www.lennoxrussia.com](http://www.lennoxrussia.com)

**SLOVAKIA**  
[www.lennox distribution.com](http://www.lennox distribution.com)

**SPAIN**  
[www.lennoxspain.com](http://www.lennoxspain.com)

**UKRAINE**  
[www.lennoxukraine.com](http://www.lennoxukraine.com)

**UNITED KINGDOM AND IRELAND**  
[www.lennoxuk.com](http://www.lennoxuk.com)

**OTHER COUNTRIES**  
[www.lennox distribution.com](http://www.lennox distribution.com)

Due to Lennox's ongoing commitment to quality, the Specifications, Ratings and Dimensions are subject to change without notice and without incurring liability.

Improper installation, adjustment, alteration, service or maintenance can cause property damage or personal injury.

Installation and service must be performed by a qualified installer and servicing agency.



CHILLER\_AC-IOM-0708-E