

NEOSYS™

APPLICATION GUIDE

Ref : NEOSYS-AGU-0108-E

1. GENERAL

General data - EUROVENT conditions	2
General description	3
Options and accessories	5

2. GENERAL DATA

General data	7
Pressure drops	10
Hydraulic data	12
Correction tables	12
Refrigeration circuit	13
Acoustic data	14
Operating limits	15

4. ELECTRICAL DATA

Electrical tables	16
-------------------	----

5. PERFORMANCES

NAC	17
NAH	18

6. DIMENSIONAL DATA

Dimensional data	20
Weight data	24

TECHNICAL DESCRIPTION	24
Technical description	24
Model number description	24

Our products comply with the European standards,



Product designed and manufactured under a quality management system certified ISO 9001,



All the technical and technological information contained in this manual, including any drawing and technical descriptions provided by us, remain the property of Lennox and must not be utilised (except in operation of this product), reproduced, issued to or made available to third parties without the prior written agreement of Lennox.



All data are at Eurovent conditions.
<http://www.eurovent-certification.com/>

PROGRAM: LCP-A-P-C-AC

NEOSYS - COOLING ONLY VERSION

NEOSYS	NKC	200	230	270	300	340	380	420	480
Cooling capacity	kW	202,1	228,6	266,3	298,8	336,5	377,0	420,1	460,2
Power input	kW	69.7	83.9	103.9	104.9	122.0	146.6	149.3	170.1
EER		2.90	2.72	2.56	2.85	2.76	2.57	2.81	2.70
CLASS EER									
ESEER		4.18	3.97	3.93	4.11	4.09	3.92	4.48	3.95
Pressure drop	kPa	28.6	36.6	37.5	47.2	45.3	38.6	39.2	46.9
Global sound power level	dB(A)	89.2	89.3	89.7	91.2	91.3	91.4	92.5	92.6

PROGRAM: LCP-A-P-R-AC

NEOSYS - REVERSIBLE VERSION

NEOSYS	NKH	200	230	270	300
Cooling capacity	kW	191	215	271	295
Power input	kW	69.5	84.8	96.9	111.5
EER		2.75	2.54	2.79	2.65
CLASS EER					
ESEER		4.00	3.76	3.99	3.94
Heating capacity	kW	219	252	313	346
Power input	kW	68.1	80.4	97.7	110.7
COP		3.21	3.13	3.20	3.12
CLASS COP					
Pressure drop	kPa	25.7	32.5	38.8	46.2
Global sound power level	dB(A)	89.2	89.3	91.1	91.2

**Air-cooled Liquid Chiller for outdoor installation (NAC)
Air-to-water Heat Pump for outdoor installation (NAH)**

Nominal cooling capacity: 200 à 460 kW (NAC) - 200 à 300 kW (NAH)

Nominal heating capacity: 200 à 300 kW (NAH)



KEY CUSTOMER BENEFITS

Sustainable Performance

- **Extended qualification tests** (vibration tests, run tests, field tests) to ensure superior reliability.
- **High efficiency aluminium micro channel heat exchanger** (MCHX) with improved corrosion resistance for moderate marine or urban applications (Cooling only version). **3-year warranty**.
- **Specific MCHX coil design** with high mechanical fin resistance that offers easy cleaning with high pressure air or water washers for extended life cycle.
- **V-coil design**, compressor and hydraulic enclosure to protect the unit against climatic conditions (e.g. sun rays, UV light, hail).
- **Exclusive Compliant Scroll® compressor design** with both axial and radial compliance to increase compressor operation tolerance of liquid refrigerant or debris, substantially improving durability and reliability. **3-year warranty**.
- **Exclusive fan design with SKF hybrid Ceramic bearings** to double (treble in some cases) to maximise the service life for of motors and to reduce noise level. With these sealed hybrid ceramic bearings, our customer can expect little or no maintenance of the motor throughout its life. **3-year warranty**.

Quiet performance

- **Unique design** with compressor, pump(s) and fan acoustic enclosure to reduce radiated noise emissions.
- **Variable speed driven fans** using external rotor technology associated with high performance aluminium fan blades of the latest generation (Shark design).
- **Elimination of intrusive fan start/stop noise** that is irritating to the human ear.
- **Active Acoustic Attenuation System™** to meet changing building load requirements while automatically adjusting the air flow to meet night and day sound level constraints (Time schedule with 4 time zones per day).

Quick performance and service

- **Complete hydraulic module** with single or twin, low or high pressure pump (options) that includes all necessary equipment for quick connection: pump(s), regulating valve, expansion tank vessel with pressure gauge, pressure tapping points, water filter, air vent, pressure relief valve and Victaulic connections.

- 400V, 50 Hz, 3 phase power supply (without neutral) with a single point of power connection. Main on/off switch included in as standard.
- **Air spring powered Butterfly Electrical Panel™** with jacks with an top opening to the top allowing a providing protection to service engineers against rain or snow during commissioning and maintenance operations.

Energy performance

- **High Seasonal Energy Efficiency Ratio** (ESEER above 4; EER up to 2.9) for improved energy consumption all around the year
- **Aluminium micro channel heat exchanger** that offers +10% offering outstanding system efficiency (Cooling only version).
- **R410A refrigerant** for optimized system performance.
- **Energy savings** due to lower system minimum water content reducing the time to reach setpoint. This can also eliminate the need for a buffer tank'

Architectural integration

- **State of the art design** with hidden compressors, fans and pump for perfect architectural integration.
- **Flat top, aesthetic grilles, very low unit height** (< 2m) for discrete installation on a roof reducing the requirement of costly cladding solutions around the unit.

Flat top and low profile for best architectural integration



The NEOSYS design is minded to be perfectly integrated into urban or residential environments. The state of the art design of NEOSYS includes a painted casing with rounded side panels,

a flat top that hides the fans, aesthetic protection grilles. The very low unit height less than two meters makes easier for architects and design engineers to integrate the unit on a roof. Many interviewed customers confirm that the state of the art design of NEOSYS will replace any requirement of costly cladding solutions around the unit

Smarts acoustics with variable speed driven fans

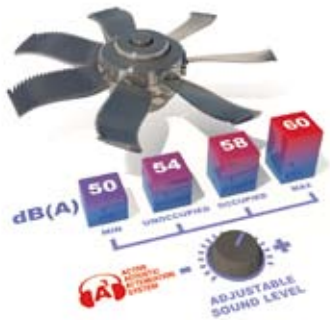

No more need to make a choice between a high efficiency version, a low noise or an ultra low noise version. NEOSYS can adapt all situations with only one version. NEOSYS is fitted in standard with the Active Acoustic Attenuation System™ that is using an electronic control associated with variable speed fans. NEOSYS can change automatically the speed of all the fans – from 0% to 100% of the nominal air flow – to meet the building load requirements while respecting maximum authorised noise level in the time zone. NEOSYS is surely achieving the best acoustic signature of the market thanks to the latest generation of shark high performance aluminium fan blades and noiseless ceramic bearings.

A high energy performance

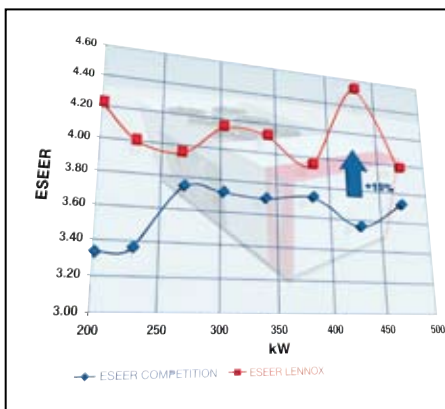

By using R410A refrigerant associated with high efficiency micro channel coils and variable speed fans NEOSYS is contributing to a very low energy consumption all year around with an average energy efficiency ratio (ESEER)* in cooling mode above 4.0. NEOSYS Heat-pumps are also achieving very high performances in cooling and heating mode (COP*

up to 3.2). Furthermore NEOSYS advanced control allows energy savings all year around by using smart control functions:

- Low water system quantity to reduce the time to reach the set-point.
- Dynamic defrost (patented) to limit the number of defrost cycles.
- Set-point reset based on outside air temperature to relax the chilled water set-point.

*ESEER: Seasonal Energy Efficiency Ratio in cooling mode. COP: Coefficient of Performance in heating mode.

R410A Micro channel heat exchanger

With the use of fully aluminium coils already used in the automotive industry, NEOSYS™ offers many customer benefits:

- Up to 40% less refrigerant charge that contributes to reduce the total amount of refrigerant used in the system.
- A more efficient system (EER + 10%).
- An air heat exchanger with significantly improved corrosion resistance results (x4) from the same aluminium alloy (no galvanic action) vs. the traditional copper tube/aluminium fin coils. By using this type of coil, units can be used in light corrosive or seacoast environments without any need for additional, and expensive, pre-treated fins or coil coating.
- High mechanical resistance eases the cleaning with high pressure air or water washers without any risk of damaging the fins.

Available in cooling only version, this technology will surely be enlarged shortly to reversible applications.

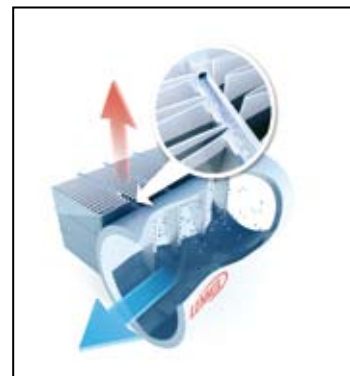

OPTIONS	DESCRIPTION	ADVANTAGES	MODELS
Low-pressure single-pump hydraulic module	Low-pressure single pump, regulating valve, Victaulic couplings, filter and all necessary hydraulic devices. Refer to specific chapter.	Quick start-up on job site. Available pressure around 150 kPA.	NAC 200 à 480 NAH 200 à 300
High-pressure single-pump hydraulic module	High-pressure single pump, regulating valve, Victaulic couplings, filter and all necessary hydraulic devices. Refer to specific chapter.	Quick start-up on job site. Available pressure around 250 kPA.	NAC 200 à 480 NAH 200 à 300
Low-pressure twin-pump hydraulic module	Low-pressure twin pumps, regulating valve, Victaulic couplings, filter and all necessary hydraulic devices. Refer to specific chapter.	Quick start-up on job site. Available pressure around 150 kPA.	NAC 200 à 480 NAH 200 à 300
High-pressure twin-pump hydraulic module	High-pressure twin pumps, regulating valve, Victaulic couplings, filter and all necessary hydraulic devices. Refer to specific chapter.	Quick start-up on job site. Available pressure around 250 kPA.	NAC 200 à 480 NAH 200 à 300
Winter operation (from +6°C down to -10°C) – Cooling only units	Unit fitted with electronic expansion valve and variable frequency driven fans. Select “anti-freeze protection” option if no glycol water	Increased operating range in cooling down to -10°C ambient temperature. (+6°C as standard).	NAC 200 à 480
Brine operation (From +5°C down to -10°C)	Unit fitted with electronic expansion valve, variable frequency driven fans and reinforced evaporator and piping thermal insulation.	Increased operating range in cooling down to -10°C water leaving temperature for thermal storage or process cooling.	NAC 200 à 480
Rear coil guard	Protection grille fitted on the rear of the unit. Note: side grilles are fitted as standard.	V-coil protection against transportation chocks or human aggressions.	NAC 200 à 480 NAH 200 à 300
Anti-freeze protection (down to -20°C)	Resistance heater on the evaporator and the hydraulic module to be selected if no glycol water.	Evaporator and hydraulic module frost protection down to -20°C ambient temperature	NAC 200 à 480 NAH 200 à 300
Soft starter	Soft starter fitted into the electrical cabinet	Start-up current reduced by 15 % up to 30 %.	NAC 200 à 480 NAH 200 à 300
Power Factor correction	Capacitors fitted into unit	Cos phi correction up to 0.95 to reduce current and energy consumption.	NAC 200 à 480 NAH 200 à 300

OPTIONS	DESCRIPTION	ADVANTAGES	MODELS
BE50™ extension board for additional inputs/ outputs	Electronic extension board with additional analog inputs (4), digital inputs (4) and digital outputs (4). See control manual.	Relay card for remote control and alarm report using dry contacts, 24 Vac or 4-20 mA signals.	NAC 200 ▶ 480 NAH 200 ▶ 300
Modbus communication interface	Communication card using ModBus/JBus protocol.	Communication interface with a building management system	NAC 200 ▶ 480 NAH 200 ▶ 300
LonWorks® communication interface	Communication card using LonTalk® protocol.	Communication interface with a building management system.	NAC 200 ▶ 480 NAH 200 ▶ 300
BACnet® communication interface	Communication card using Bacnet® protocol.	Communication interface with a building management system.	NAC 200 ▶ 480 NAH 200 ▶ 300

ACCESSORIES	DESCRIPTION	ADVANTAGES	MODELS
Water filter	1000 microns water filter delivered with piping and Victaulic connections. Not necessary if 'hydraulic module' option selected.	This protection must be fitted in the customer water supply piping to protect the evaporator from any possible impurities.	NAC 200 ▶ 480 NAH 200 ▶ 300
Victaulic connection sleeve	Connection sleeve with Victaulic groove at one end and unfinished at the other.	Connection sleeve for the customer to make the connection of his choice (grooved, welded, flanged).	NAC 200 ▶ 480 NAH 200 ▶ 300
Anti-vibration mounts	Rubber anti-vibration mounts to be mounted under the unit.	Reduction of the transmission of vibration to the ground and the general level.	NAC 200 ▶ 480 NAH 200 ▶ 300
DC50™ remote comfort display	Customer display located at 600 meters maximum from the unit.	Remote customer parameter reading and modification.	NAC 200 ▶ 480 NAH 200 ▶ 300
DS50™ service display	Plug and play display delivered with 1 meter cable and connector for quick connection on Climatic controller.	Display for service technicians only.	NAC 200 ▶ 480 NAH 200 ▶ 300
Adalink™ supervision	Electronic board with RS485 cables, RJ11 phone cable, Ethernet cable and power supply cable.	Remote supervision of the unit via an intuitive web page.	NAC 200 ▶ 480 NAH 200 ▶ 300

NAC

NEOSYS	NAC	200	230	270	300
Cooling mode					
Cooling capacity ⁽¹⁾	kW	202,1	228,6	266,3	298,8
Power input ⁽¹⁾	kW	69.7	83.9	103.9	104.9
Full load amps ⁽¹⁾	A	123,9	145,5	174,9	185,4
EER ⁽²⁾		2.90	2.72	2.56	2.85
ESEER ⁽³⁾		4.18	3.97	3.93	4.11
Compressor					
Scroll - Hermetic					
Number of compressor	nr	4	4	4	4
Capacity steps	%	19 - 31 - 50 - 62 - 81 - 100	16 - 34 - 50 - 68 - 84 - 100	22 - 28 - 50 - 57 - 78 - 100	20 - 27 - 53 - 73 - 100
Oil charge per compressor	l	(3,2+6,8) + (3,2+6,8)	(3,2+6,3) + (3,2+6,3)	(6,8+6,3) + (6,8+6,3)	(6,8x2) + (6,8+6,3)
Oil type	type	MOBIL EAL Arctic 22CC or ICI EMKARATE RL32CF			
Refrigerant					
R410A					
Expansion	type	Thermostatic expansion valve			
Number of circuit	nr	2	2	2	2
Charge per circuit	kg				
Condenser					
Microchannel Aluminium Tube and fins - Air cooled					
Face area	m ²	9.6	9.6	9.6	14.4
Number of rows		1	1	1	1
Fin spacing	mm	MCHX 1.6	MCHX 1.6	MCHX 1.6	MCHX 1.6
Fan & Motor					
Axial fan					
Number of fan		4	4	4	6
Diameter	mm	800	800	800	800
Maximum speed	RPM	Variable speed - 900 rpm maximum			
Nominal air flow (100%)	m ³ /h	87 200	87 200	87 200	130 800
External static pressure	Pa	0	0	0	0
Total motor power input (900 rpm)	kW	6.4	6.4	6.4	9.6
Evaporator					
AISI 316 stainless steel plate brazed with copper heat exchanger					
Water flow ⁽¹⁾	m ³ /h	34.8	39.3	45.8	51.4
Water volume	l	20	20	23.2	23.2
Pressure drop ⁽¹⁾	kPa	28.6	36.6	37.5	47.2
Water operating pressure	kPa	600	600	600	600
Hydraulic connections					
Victaulic					
Water inlet/outlet with Hydro	Inches	4"	4"	4"	4"
Acoustic					
Global sound power level ⁽¹⁾	dB(A)	89.2	89.3	89.7	91.2
Electrical data					
400V / III / 50 Hz					
Start-up intensity	A	395.1	444.8	473.7	504.3
Maximum current	A	168.0	191.4	220.3	250.9
Operating limits					
Min. outlet water temperature	°C	5			
Max. inlet water temperature	°C	20			
Min. difference water inlet/outlet	°C	3			
Max. difference water inlet/outlet	°C	8			
Min. outside air temperature	°C	6			
Max. outside air temperature ⁽⁴⁾	°C	46			
Dimensions					
Length	mm	3590	3590	3590	4620
Width	mm	2280	2280	2280	2280
Height	mm	1964	1964	1964	1964
Footprint	m ²	8.2	8.2	8.2	10.5
Operating weight	kg	Please consult us			
Shipping weight	kg	2246	2272	2520	2877
Construction					
Frame		Galvanised steel			
Casing		Aluminium and galvanised steel			
Painting		Polyester - RAL 9002/RAL 7016			

(1) All data are at Eurovent condition,
Gross cooling capacity with 12/7°C water temperature and 35°C air ambient,
Gross heating capacity with 7°C air inlet temperature and 40/45°C water temperature

(2) EER and COP with fans
(3) ESEER according to EN14511 Eurovent calculation method
(NA) Not available,

NAC

NEOSYS	NKC	340	380	420	480
Cooling mode					
Cooling capacity ⁽¹⁾	kW	336,5	377,0	420,1	460,2
Power input ⁽¹⁾	kW	122,0	146,6	149,3	170,1
Full load amps ⁽¹⁾	A	206,3	243,4	252,7	284,8
EER ⁽²⁾		2,76	2,57	2,81	2,70
ESEER ⁽³⁾		4,09	3,92	4,48	3,95
Compressor					
Scroll - Hermetic					
Number of compressor	nr	5	5	6	6
Capacity steps	%	18 - 23 - 36 - 59 - 77 - 100	20 - 40 - 60 - 100	14 - 19 - 29 - 48 - 67 - 81 - 100	14 - 33 - 48 - 67 - 81 - 100
Oil charge per compressor	l	(6,8x3) + (6,3x2)	(6,3x3) + (6,3x2)	(6,3x3) + (6,8x3)	(6,3x3) + (6,3x3)
Oil type	type	MOBIL EAL Arctic 22CC or ICI EMKARATE RL32CF			
Refrigerant					
R410A					
Expansion	type	Thermostatic expansion valve			
Number of circuit	nr	2	2	2	2
Charge per circuit	kg				
Condenser					
Microchannel Aluminium Tube and fins - Air cooled					
Face area	m ²	14,4	14,4	19,2	19,2
Number of rows		1	1	1	1
Fin spacing	mm	MCHX 1.6	MCHX 1.6	MCHX 1.6	MCHX 1.6
Fan & Motor					
Axial fan					
Number of fan		6	6	8	8
Diameter	mm	800	800	800	800
Maximum speed	RPM	Variable speed - 900 rpm maximum			
Nominal air flow (100%)	m ³ /h	130 800	130 800	174 400	174 400
External static pressure	Pa	0	0	0	1
Total motor power input (900 rpm)	kW	9,6	9,6	12,8	12,8
Evaporator					
AISI 316 stainless steel plate brazed with copper heat exchanger					
Water flow ⁽¹⁾	m ³ /h	57,9	64,9	72,3	79,2
Water volume	l	27,2	34,4	39,2	39,2
Pressure drop ⁽¹⁾	kPa	45,3	38,6	39,2	46,9
Water operating pressure	kPa	600	600	600	600
Hydraulic connections					
Victaulic					
Water inlet/outlet with Hydro	Inches	5"	5"	5"	5"
Acoustic					
Global sound power level ⁽¹⁾	dB(A)	91,3	91,4	92,5	92,6
Electrical data					
400V / III / 50 Hz					
Start-up intensity	A	526,2	561,3	591,3	626,5
Maximum current	A	272,8	307,9	338,0	373,0
Operating limits					
Min. outlet water temperature	°C	5			
Max. inlet water temperature	°C	20			
Min. difference water inlet/outlet	°C	3			
Max. difference water inlet/outlet	°C	8			
Min. outside air temperature	°C	6			
Max. outside air temperature ⁽⁴⁾	°C	46			
Dimensions					
Length	mm	4620	4620	5650	5650
Width	mm	2280	2280	2280	2280
Height	mm	1964	1964	1964	1964
Footprint	m ²	10,5	10,5	12,9	12,9
Operating weight	kg	Please consult us			
Shipping weight	kg	3147	3184	3704	3782
Construction					
Frame		Galvanised steel			
Casing		Aluminium and galvanised steel			
Painting		Polyester - RAL 9002/RAL 7016			

(1) All data are at Eurovent condition,
Gross cooling capacity with 12/7°C water temperature and 35°C air ambient,
Gross heating capacity with 7°C air inlet temperature and 40/45°C water temperature

(2) EER and COP with fans

(3) ESEER according to EN14511 Eurovent calculation method

(NA) Not available,

NAH

NEOSYS	NKH	200	230	270	300
Cooling mode					
Cooling capacity ⁽¹⁾	kW	191	215	271	295
Power input ⁽¹⁾	kW	69,5	84,8	96,9	111,5
Full load amps ⁽¹⁾	A	127,5	151,1	170,9	193,5
EER ⁽²⁾		2,75	2,54	2,79	2,65
ESEER ⁽³⁾		4,00	3,76	3,99	3,94
Heating mode					
Heating capacity ⁽¹⁾	kW	219	252	313	346
Power input ⁽¹⁾	kW	68,1	80,4	97,7	110,7
Full load amps ⁽¹⁾	A	125,9	145,3	172,8	192,5
COP ⁽³⁾		3,21	3,13	3,20	3,12
Compressor					
Scroll - Hermetic					
Number of compressor	nr	4	4	4	4
Capacity steps	%	19 - 31 - 50 - 62 - 81 - 100	16 - 34 - 50 - 68 - 84 - 100	22 - 28 - 50 - 57 - 78 - 100	25 - 50 - 75 - 100
Oil charge per compressor	l	(3,2+6,8) + (3,2+6,8)	(3,2+6,3) + (3,2+6,3)	(6,8+6,3) + (6,8+6,3)	(6,8x2) + (6,8x2)
Oil type	type	MOBIL EAL Arctic 22CC or ICI EMKARATE RL32CF			
Refrigerant					
R410A					
Expansion	type	Thermostatic expansion valve			
Number of circuit	nr	2	2	2	2
Charge per circuit	kg				
Condenser					
Copper tube - Aluminium fin - Air-cooled					
Face area	m ²	9,6	9,6	14,4	14,4
Number of rows		3	3	3	3
Fin spacing	mm	1,6	1,6	1,6	1,6
Fan & Motor					
Axial fan					
Number of fan		4	4	6	6
Diameter	mm	800	800	800	800
Maximum speed	RPM	Variable speed - 900 rpm maximum			
Nominal air flow (100%)	m ³ /h	76 000	76 000	114 000	114 000
External static pressure	Pa	0	0	0	0
Total motor power input	kW	6,4	6,4	9,6	9,6
Evaporator					
AISI 316 stainless steel plate brazed with copper heat exchanger					
Water flow ⁽¹⁾	m ³ /h	32,9	37,0	46,6	50,8
Water volume	l	20	20	23,2	23,2
Pressure drop ⁽¹⁾	kPa	25,7	32,5	38,8	46,2
Water operating pressure	kPa	600	600	600	600
Hydraulic connections					
Victaulic					
Water inlet/outlet with Hydro	Inches	4"	4"	4"	4"
Acoustic					
Global sound power level ⁽¹⁾	dB(A)	89,2	89,3	91,1	91,2
Electrical data					
400V / III / 50 Hz					
Start-up intensity	A	39531	444,8	480,9	504,3
Maximum current	A	168,0	191,4	227,5	250,9
Operating limits					
Min. outlet water temperature - Cooling mode	°C	5			
Max. inlet water temperature	°C	20			
Min. outside air temperature - Cooling mode	°C	6			
Max. outside air temperature - Cooling mode	°C	46			
Max. outlet water temperature - Heating mode	°C	50			
Max. outside air temperature - Heating mode	°C	- 12			
Dimensions					
Length	mm	3590	3590	4620	4620
Width	mm	2280	2280	2280	2280
Height	mm	1964	1964	1964	1964
Footprint	m ²	8,2	8,2	10,5	10,5
Operating weight	kg	Please consult us			
Shipping weight	kg	Please consult us			
Construction					
Frame		Galvanised steel			
Casing		Aluminium and galvanised steel			
Painting		Polyester - RAL 9002/RAL 7016			

(1) All data are at Eurovent condition.

Gross cooling capacity with 12/7°C water temperature and 35°C air ambient.
Gross heating capacity with 7°C air inlet temperature and 40/45°C water temperature.

(2) EER and COP with fans

(3) (5) ESEER according to EN14511 Eurovent calculation method

EVAPORATORS CURVE

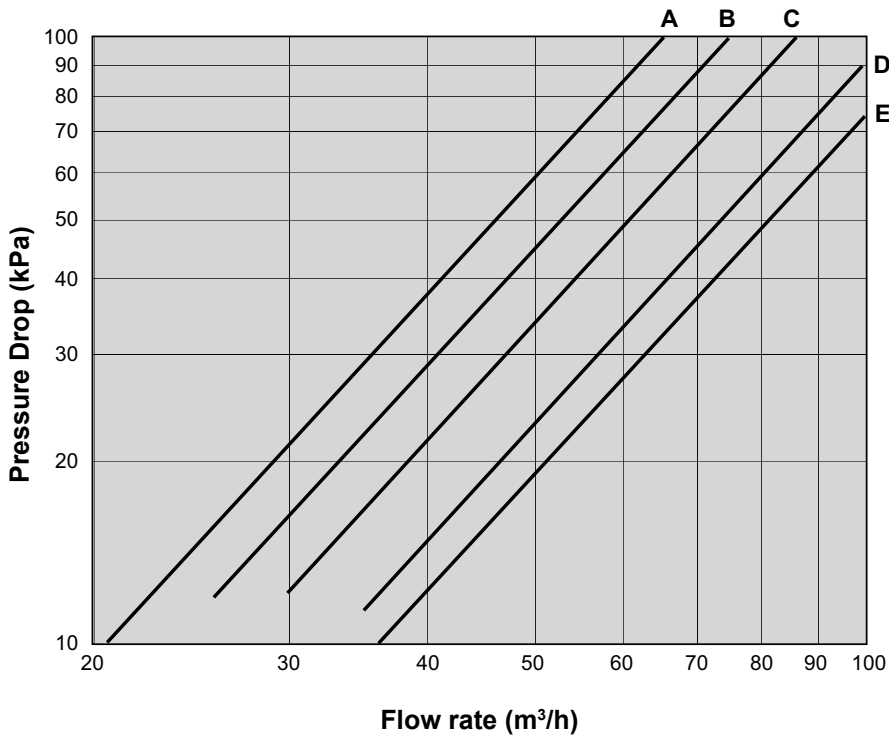

NAC/NAH	Curve
200	A
230	A
270	B
300	B
340	C
380	D
420	E
480	E

FILTER CURVE

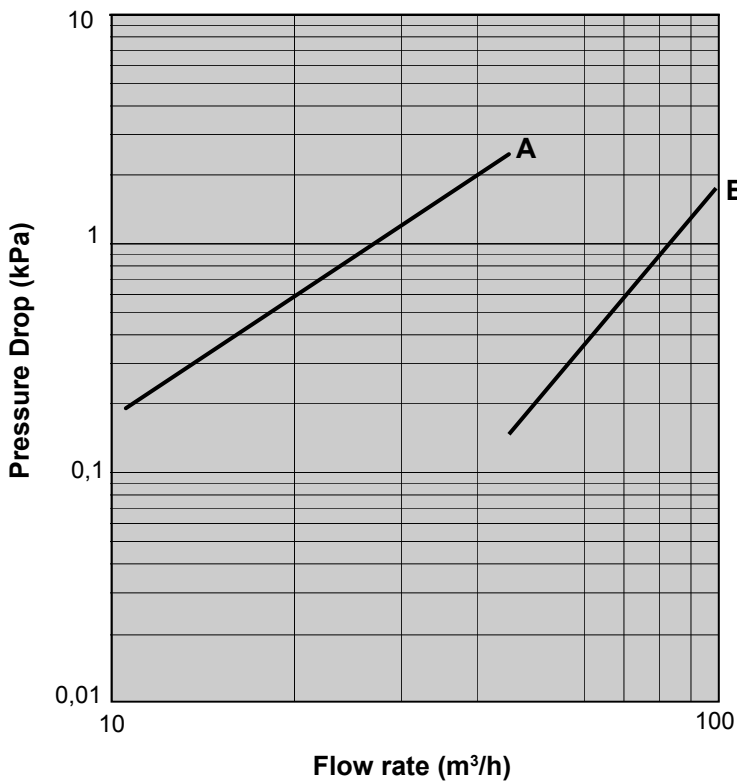

NAC/NAH	Curve
200	A
230	A
270	A
300	A
340	A
380	B
420	B
480	B

Pressure drops are given for informations only, A tolerance of +/- 20kPa must be considered when selecting water pumps,

NAC - NAH		200	230	270	300	340	380	420	480
<i>Nominal water flow</i>	<i>m³/h</i>	34.8	39.3	45.8	51.4	57.9	64.9	72.3	79.2
Single pump									
Available static pressure (1)	kPa	110	119	107	117	121	147	132	114
Double pump									
Available static pressure (1)	kPa	105	109	102	112	111	137	127	109
Single pump HP									
Available static pressure (1)		208	236	215	200	205	206	225	207
Double pump HP									
Available static pressure (1)		198	226	215	200	205	201	215	192
Expansion vessel									
Volume	l	50	50	80	80	80	80	80	80
Maximum pressure	kPa	400	400	400	400	400	400	400	400
Gross Weight	kg	6.9	6.9	6.9	6.9	6.9	6.9	6.9	6.9

(1) : Pump external static pressure - Evaporator pressure drop

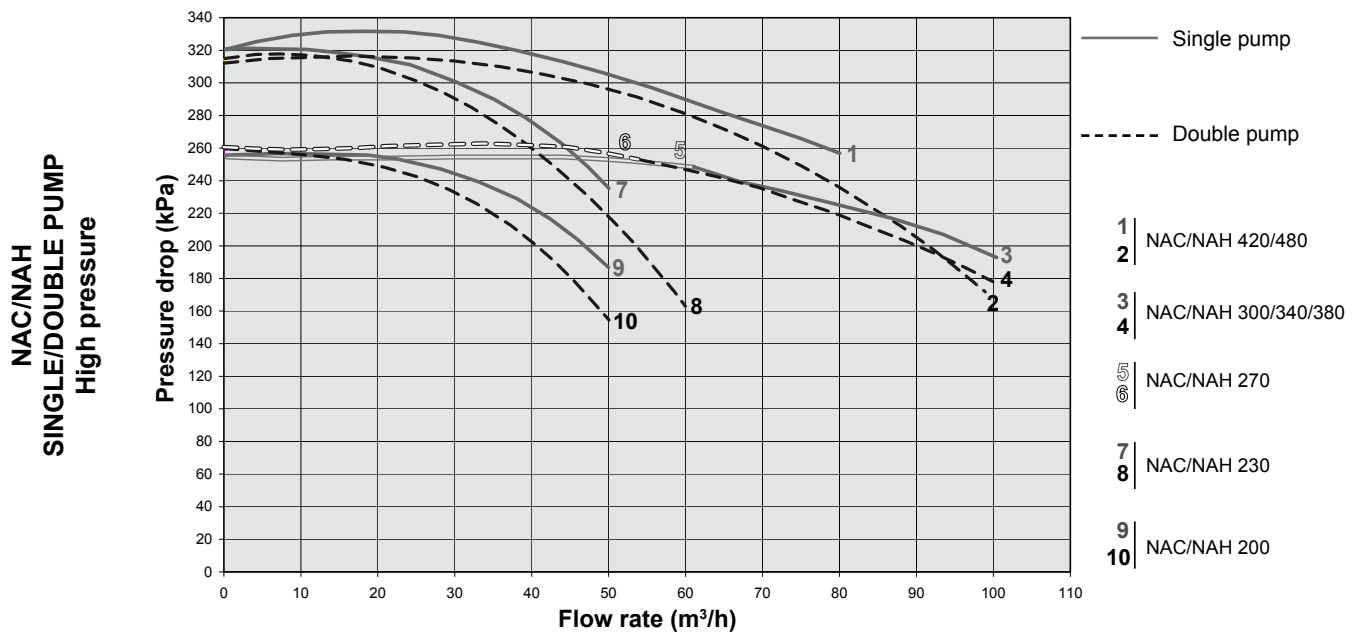
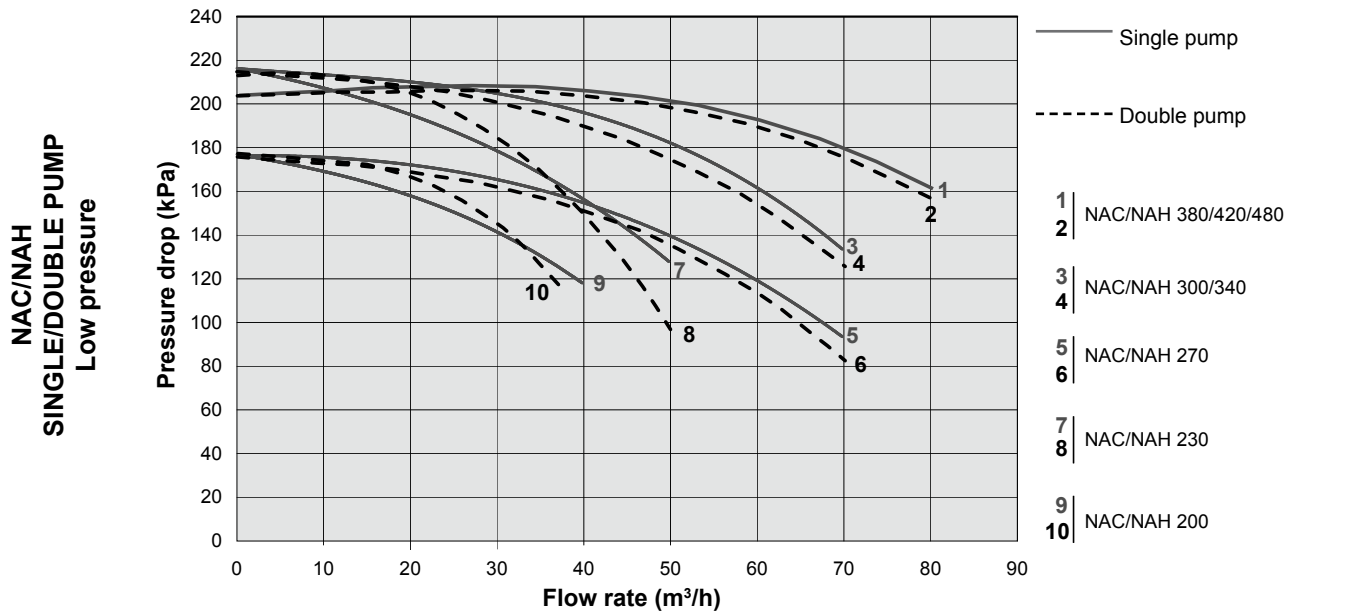

UNIT WITH HYDRAULIC MODULE

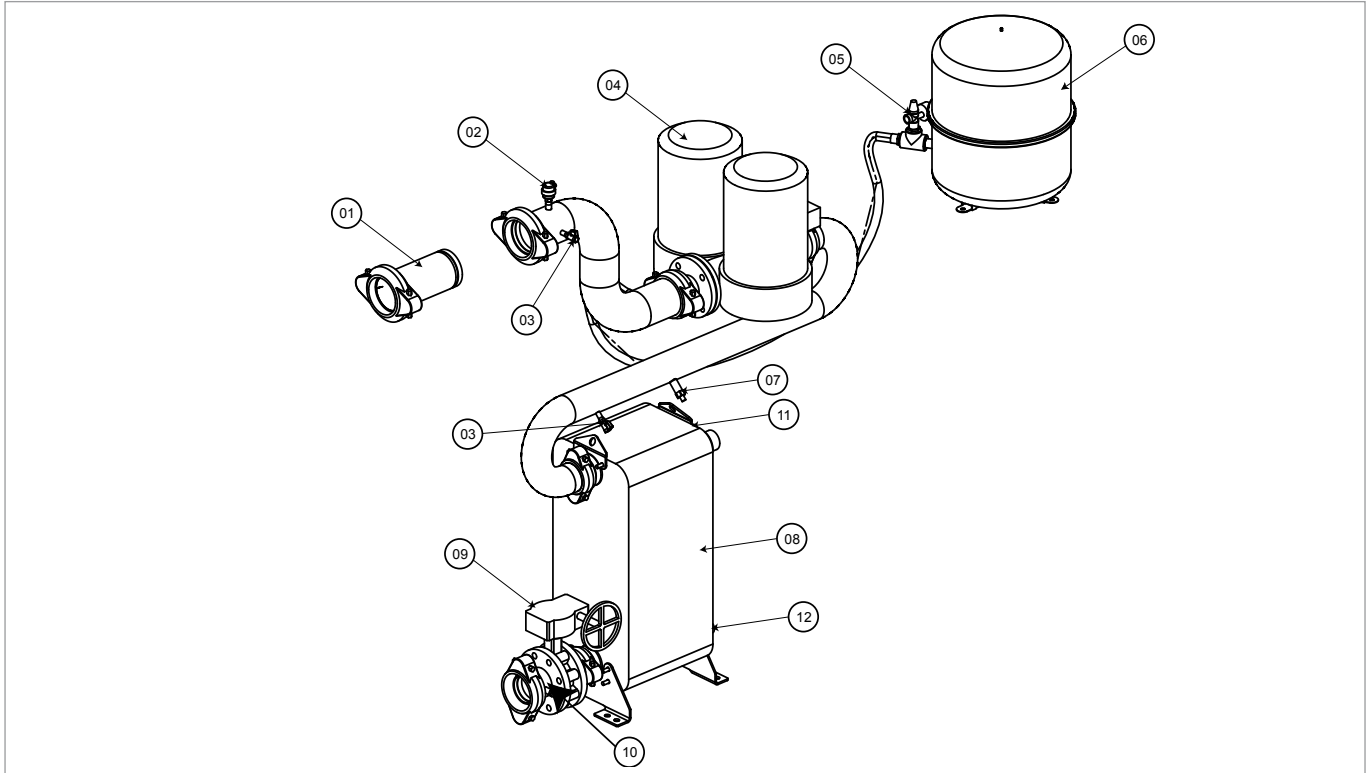

01	Water filter (item supplied loose)	07	Electronic flow switch
02	Air purge	08	Plate heat exchanger
03	Pressure tap	09	Setting valve
04	Pump	10	Pressure tap and drain valve
05	Safety valve with manometer	11	Return temperature sensor
06	Expansion vessel	12	Supply temperature sensor

CORRECTION TABLES

GLYCOL CORRECTION FACTOR

Minimum Ambient Temperature or Water Outlet Temperature	Ethylene Glycol	Pressure Drop	Water Flow	CAPACITIES	
				Cooling	Heating
From +5°C to 0°C	10%	1,05	1,02	0,99	0,994
From 0°C to -5°C	20%	1,10	1,05	0,98	0,993
From -5°C to -10°C	30%	1,15	1,08	0,97	0,99
From -10°C to -15°C	35%	1,18	1,10	0,96	0,987

Example : 10% glycol
 Minimum flow : 1,19 m³/h x 1,02
 Pressure drop x 1,07
 System capacity x 0,99

REFRIGERANT DRAWING

NAC

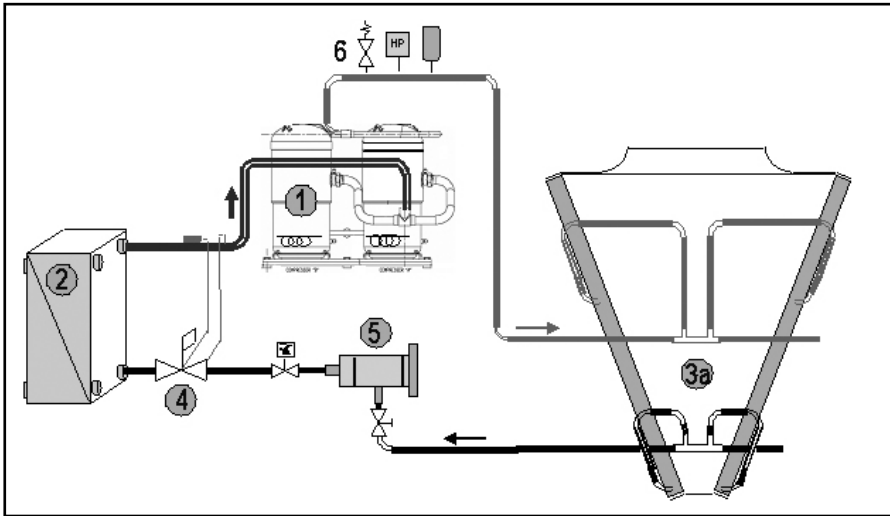

LEGEND

1	Compressors
2	Plate heat exchanger
3a	MCHX condenser
3b	Fin and tube coil
4	Thermostatic expansion valves
5	Cartridge filter dryer
6	High pressure relief valve
7	Liquid receiver
	Crankcase heaters

NAH

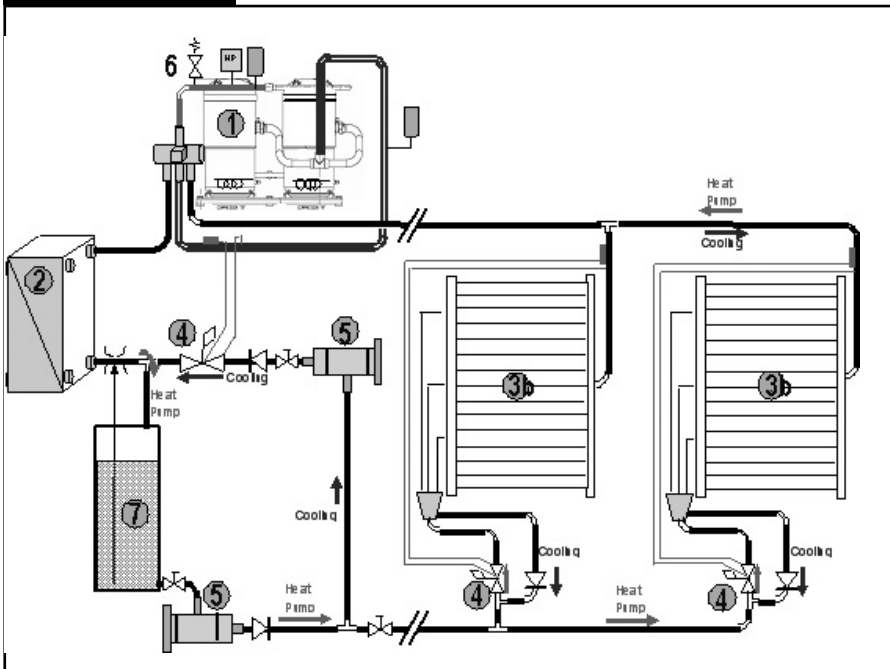

NAC

Spectrum per octave band (dBa)									Global sound power	Sound pressure at 10 meters	Sound pressure at 10 meters enveloping surface
NAC	63 Hz	125 Hz	250 Hz	500 Hz	1000 Hz	2000 Hz	4000 Hz	8000 Hz	EUROVENT Lw dB(A)	(1) Pw dB(A)	(2) Pw dB(A)
200		68	79	83	85	82	75	68	89.2	61	58
230		68	80	84	85	82	76	68	89.3	61	58
270		68	80	84	85	83	76	68	89.7	62	58
300		70	82	85	87	84	78	70	91.2	63	60
340		70	82	85	87	84	78	70	91.3	63	60
380		70	82	86	87	84	78	70	91.4	63	60
420		71	83	87	88	85	79	71	92.5	64	61
480		71	83	87	88	86	79	71	92.6	65	61

(1) : For information only.
Data calculated by semi spheric method in free open field

(2) : For information only.
Data calculated by enveloping surface method in free open field

NAH

Spectrum per octave band (dBa)									Global sound power	Sound pressure at 10 meters	Sound pressure at 10 meters enveloping surface
NAH	63 Hz	125 Hz	250 Hz	500 Hz	1000 Hz	2000 Hz	4000 Hz	8000 Hz	EUROVENT Lw dB(A)	(1) Pw dB(A)	(2) Pw dB(A)
200		68	79	83	85	82	75	68	89.2	61	58
230		68	80	84	85	82	76	68	89.3	61	58
270		70	82	85	87	84	78	70	91.1	63	60
300		70	82	85	87	84	78	70	91.2	63	60

(1) : For information only.
Data calculated by semi spheric method in free open field

(2) : For information only.
Data calculated by enveloping surface method in free open field

Free filed Semi Spherique

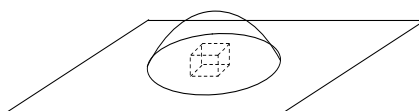

$$L_p = L_w - 10 \log 2\pi d^2$$

Enveloping Surface

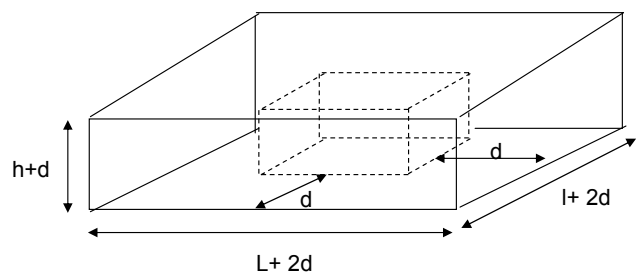

$$A = 2(L+2d)(h+d)+2(l+2d)(h+d)+(L+2d)(l+2d)$$

NAC

NAC		200 - 230 - 270 - 300 - 340 - 380 - 420 - 480
Min. outlet water temperature	°C	5
Max. inlet water temperature	°C	20
Min. difference water inlet/outlet	°C	3
Max. difference water inlet/outlet	°C	8
Min. outside air temperature	°C	6
Min. outside air temperature with low ambient kit	°C	- 10
Maximum outside air temperature : Full capacity operation	°C	46

NAH

NAH - Cooling mode	NAH	200	230	270	300
Min. outlet water temperature	°C	5			
Max. inlet water temperature	°C	20			
Min. difference water inlet/outlet	°C	3			
Max. difference water inlet/outlet	°C	8			
Min. outside air temperature	°C	6			
Min. outside air temperature with low ambient kit	°C	- 10			
Maximum outside air temperature : Full capacity operation	°C	46			

NAH - Heating mode	NAH	200	230	270	300
Min. condenser outlet water temperature	°C	24			
Max. condenser outlet water temperature	°C	50			
Min. difference water inlet/outlet	°C	3			
Max. difference water inlet/outlet	°C	8			
Min. outside air temperature (Water outlet temp. : 12/7°C)	°C	- 12			
Max. outside air temperature	°C	30			

NAC / NAH
Operating envelope
Cooling mode

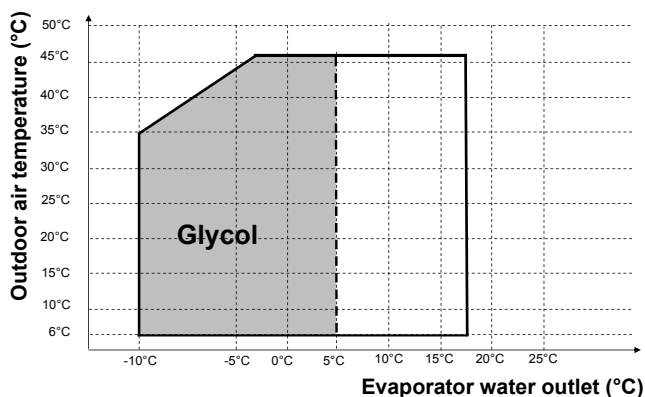

NAH
Operating envelope
Heating mode

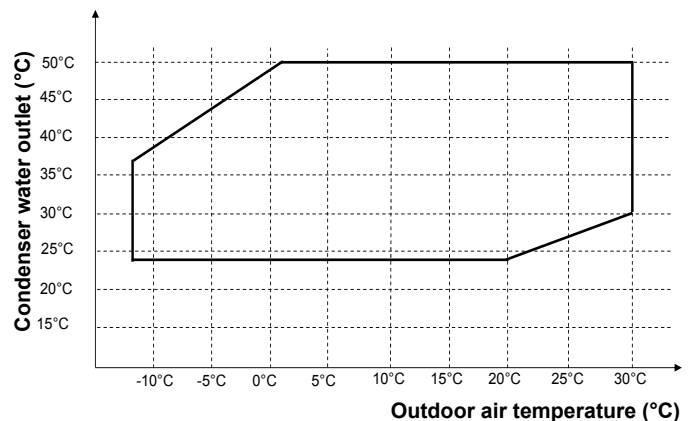

NAC / NAH

UNITS

NEOSYS		NAC	200	230	270	300	340	380	420	480
		NAH	200	230	270	300	-	-	-	-
Minimum and maximum voltage	V		380 V / 420 V							
Maximum power	kW	NAC	95.8	112.0	132.7	152.1	163.4	187.7	202.3	226.6
		NAH	95.8	112.0	227.5	152.1	-	-	-	-
Maximum current	A	NAC	168.0	191.4	220.3	250.9	272.8	307.9	338.0	373.0
		NAH	168.0	191.4	208.0	250.9	-	-	-	-
Maximum current (with cos phi 0,95 option)	A	NAC	146.9	171.6	203.1	232.6	249.9	286.8	309.9	346.8
		NAH	146.9	171.6	208.0	232.6	-	-	-	-
Start-up intensity	A	NAC	395.1	444.8	473.7	504.3	526.2	561.3	591.3	626.5
		NAH	395.1	444.8	480.9	504.3	-	-	-	-
Start-up intensity (with sofstarter option)	A	NAC	286.3	320.8	349.7	380.3	402.2	437.3	467.4	502.4
		NAH	286.3	320.8	356.9	380.3	-	-	-	-
Start-up intensity (with cos phi 0,95 option)	A	NAC	268.7	303.8	335.4	364.8	382.1	419.0	442.1	479.0
		NAH	268.7	303.8	340.2	364.8	-	-	-	-

FANS

NEOSYS		NAC	200	230	270	300	340	380	420	480
		NAH	200	230	270	300	-	-	-	-
Nominal air flow	m³/h		87200	87200	87200	130800	130800	130800	174400	174400
Available static pressure	kPa		0	0	0	0	0	0	0	0
Absorbed power	kW		6.4	6.4	6.4	9.6	9.6	9.6	12.8	12.8

OPTIONS

NEOSYS		NAC	200	230	270	300	340	380	420	480
		NAH	200	230	270	300	-	-	-	-
Low pressure	Single pump Double pump	kW	2.20	3.00	3.00	4.00	4.00	5.50	5.50	5.50
	Single pump - Double pump Maximum current	A	4.90	6.10	6.10	7.50	7.50	10.50	10.50	10.50
High pressure	Single pump Double pump	kW	4.00	5.50	5.50	7.50	7.50	7.50	7.50	7.50
	Single pump - Double pump Maximum current	A	7.50	10.50	10.50	14.30	14.30	14.30	14.30	14.30
Evaporator anti-freeze heater (option)		kW	0.13	0.13	0.13	0.13	0.13	0.13	0.13	0.13
Maximum current		A	0.32	0.32	0.32	0.32	0.32	0.32	0.32	0.32
Hydraulic anti-freeze heater (option)		kW	0.13	0.13	0.13	0.13	0.24	0.24	0.24	0.24
Maximum current		A	0.32	0.32	0.32	0.32	0.60	0.60	0.60	0.60

NAC	Air inlet temperature																																
	28 °C			30 °C			32 °C			35 °C			38 °C			40 °C			43 °C			46 °C											
	Pc	Pe	Wf	Dp	Pe	Wf	Dp	Pe	Wf	Dp	Pe	Wf	Dp	Pe	Wf	Dp	Pe	Wf	Dp	Pe	Wf	Dp	Pe	Wf	Dp	Pe	Wf						
kW	kW	m³/h	kPa	kW	m³/h	kPa	kW	m³/h	kPa	kW	m³/h	kPa	kW	m³/h	kPa	kW	m³/h	kPa	kW	m³/h	kPa	kW	m³/h	kPa	kW	m³/h	kPa	kW	m³/h				
5 °C	200	204.2	71.1	35.1	292	200.1	63.1	34.4	28.1	195.8	65.3	33.7	26.9	189.0	68.8	32.5	25.1	181.9	72.6	31.3	23.2	176.9	75.3	30.4	22.0	169.2	79.6	29.1	20.1	161.0	84.3	27.7	18.2
	230	229.9	73.3	39.6	370	225.8	75.7	38.8	35.7	221.2	78.3	38.1	34.3	213.9	82.7	36.8	32.1	205.8	87.4	35.4	29.7	200.1	90.9	34.4	28.1	190.9	96.4	32.8	25.6	180.9	102.4	31.1	23.0
	270	272.3	90.9	46.8	392	266.7	93.8	45.9	37.7	260.8	97.0	44.9	36.0	251.2	102.3	43.2	33.4	240.8	108.3	41.4	30.7	233.5	112.6	40.4	28.9	221.7	119.5	38.2	26.0	209.0	127.1	36.0	23.2
	300	307.3	92.5	51.8	480	295.9	95.3	50.9	46.3	290.2	98.5	49.9	44.5	280.8	103.6	48.3	41.7	270.7	109.4	46.6	38.8	263.4	113.6	45.3	36.7	251.8	120.3	43.3	33.2	239.4	127.7	41.2	30.4
	340	342.8	128.1	66.2	402	377.5	132.2	64.9	38.7	369.5	136.8	63.6	37.1	356.4	144.5	61.3	34.5	305.4	127.2	52.5	37.4	296.8	132.0	51.1	35.3	283.2	139.9	48.7	32.2	268.7	148.4	46.2	29.0
6 °C	200	384.8	128.1	66.2	402	377.5	132.2	64.9	38.7	369.5	136.8	63.6	37.1	356.4	144.5	61.3	34.5	341.8	153.0	58.8	31.8	331.3	159.3	57.0	29.9	314.3	169.4	54.1	26.9	295.9	180.5	50.9	23.8
	230	426.4	131.3	73.4	402	418.3	135.5	72.0	38.8	409.6	139.9	70.5	37.2	395.8	147.4	68.1	34.8	380.7	155.6	65.5	32.2	370.1	161.6	63.7	30.4	363.2	171.3	60.8	27.7	335.2	181.7	57.7	25.0
	270	465.7	149.3	80.1	480	457.4	154.0	78.7	46.4	448.5	159.2	77.2	44.6	433.7	167.8	74.6	41.7	417.3	177.6	71.8	38.6	405.4	184.7	69.8	36.5	396.3	196.2	66.5	33.2	365.6	208.7	62.9	29.7
	300	211.3	61.5	36.3	313	207.0	63.6	35.6	30.0	202.5	65.8	34.8	28.8	195.5	69.3	33.6	26.8	188.2	73.1	32.4	24.9	183.1	75.8	31.5	23.5	175.0	80.2	30.1	21.5	166.7	84.8	28.7	19.5
	340	238.1	73.9	41.0	397	233.7	76.3	40.2	38.2	228.9	79.0	39.4	36.7	221.3	83.3	38.1	34.3	212.9	88.1	36.6	31.8	206.9	91.5	35.6	30.0	197.4	97.0	34.0	27.3	187.1	103.0	32.2	24.6
7 °C	200	280.5	91.6	48.3	417	274.8	94.6	47.3	40.0	288.6	97.8	46.2	38.2	258.7	103.1	44.5	35.4	248.0	109.1	42.7	32.6	240.3	113.4	41.4	30.6	228.2	120.4	39.3	27.6	215.2	128.0	37.0	24.6
	230	311.1	93.1	53.5	512	305.5	96.0	52.6	49.4	299.5	99.1	51.5	47.4	289.8	104.3	49.9	44.4	279.2	110.0	48.0	41.3	271.7	114.2	46.7	39.1	259.8	121.0	44.7	35.7	246.9	128.3	42.5	32.3
	270	353.1	108.1	60.7	499	346.1	111.5	59.5	48.0	338.7	115.2	58.3	46.0	327.0	121.2	56.3	42.8	314.4	128.0	54.1	39.6	305.5	132.8	52.6	37.4	291.5	140.7	50.1	34.1	276.6	149.2	47.6	30.7
	300	396.2	129.1	68.2	427	388.6	133.3	66.9	41.0	380.3	137.9	65.4	39.3	366.7	145.5	63.1	36.6	351.6	154.1	60.5	33.6	340.7	160.3	58.6	31.6	323.3	170.5	55.6	28.4	304.3	181.5	52.4	25.2
	340	439.7	132.3	75.6	429	431.2	136.4	74.2	41.2	422.3	140.9	72.6	39.6	407.9	148.3	70.2	36.9	392.3	156.6	67.5	34.2	381.3	162.5	65.6	32.3	363.9	172.2	62.6	29.5	345.4	182.7	59.4	26.5
8 °C	200	480.3	150.4	82.6	51.1	471.6	155.1	81.1	49.3	462.2	160.3	79.5	47.3	446.9	169.0	76.9	44.3	429.8	178.7	74.0	41.0	417.6	185.8	71.8	38.7	397.9	197.3	68.5	35.2	376.6	209.9	64.8	31.5
	230	218.3	62.0	37.6	334	213.9	64.0	36.8	32.1	209.3	66.2	36.0	30.7	202.1	69.7	34.8	28.6	194.4	73.6	33.5	26.5	189.2	76.3	32.5	25.1	180.9	80.7	31.1	23.0	172.3	85.3	29.6	20.9
	270	246.2	74.5	42.3	424	241.5	76.9	41.6	40.8	236.6	79.6	40.7	39.2	228.6	83.9	39.3	36.6	219.9	88.7	37.8	33.9	213.7	92.2	36.8	32.0	203.9	97.7	35.1	29.2	193.3	103.7	33.3	26.2
	300	288.9	92.4	49.7	442	282.9	95.4	48.7	42.3	276.5	98.6	47.6	40.5	266.3	103.9	45.8	37.5	255.2	109.9	43.9	34.5	247.3	114.2	42.5	32.4	234.8	121.2	40.4	29.2	221.5	128.8	38.1	26.0
	340	321.0	93.8	55.2	545	315.1	96.6	54.2	52.5	308.9	99.7	53.1	50.5	298.8	104.9	51.4	47.2	287.9	110.7	49.5	43.9	280.1	114.9	48.2	41.5	267.8	121.6	46.1	38.0	254.6	129.0	43.8	34.3
9 °C	200	363.5	108.9	62.5	529	356.2	112.2	61.3	50.8	348.6	115.9	60.0	48.7	336.5	122.0	57.9	45.3	323.5	128.8	55.7	41.9	314.3	133.7	54.1	39.6	299.9	141.5	51.6	36.1	284.6	150.1	49.0	32.5
	230	407.8	130.2	70.2	452	399.8	134.4	68.8	43.4	391.2	138.9	67.3	41.6	377.0	146.6	64.9	38.6	361.5	155.2	62.2	35.5	350.3	161.4	60.3	33.4	332.3	171.5	57.2	30.1	312.9	182.6	53.8	26.7
	270	453.1	133.2	78.0	455	444.3	137.3	76.4	43.8	435.0	141.8	74.8	42.0	420.1	149.3	72.3	39.2	404.1	157.5	69.5	36.2	392.7	163.5	67.6	34.3	374.8	173.2	64.5	31.2	355.8	183.7	61.2	28.2
	300	495.0	151.6	85.2	542	485.9	156.3	83.6	52.3	476.1	161.5	81.9	50.2	460.2	170.1	79.2	46.9	442.5	179.9	76.1	43.4	429.9	187.0	74.0	41.0	409.6	198.5	70.5	37.2	387.7	211.0	66.7	33.4
	340	225.4	62.4	38.8	356	220.8	64.5	38.0	34.2	216.1	66.7	37.2	32.7	208.6	70.2	35.9	30.5	200.7	74.1	34.5	28.3	195.3	76.8	33.6	26.8	186.8	81.2	32.1	24.5	177.9	85.9	30.6	22.2
10 °C	200	254.2	75.1	43.7	452	249.4	77.6	42.9	43.5	244.2	80.2	42.0	41.8	235.9	84.6	40.6	39.0	226.9	89.4	39.0	36.1	220.5	92.8	37.9	34.1	210.3	98.4	36.2	31.0	199.4	104.4	34.3	27.9
	230	297.3	93.2	51.1	467	291.0	96.2	50.1	44.8	284.4	99.4	48.9	42.8	273.8	104.8	47.1	39.7	262.4	110.7	45.1	36.5	254.3	115.1	43.8	34.3	241.5	122.1	41.5	30.9	227.8	129.7	39.2	27.5
	270	331.0	94.4	56.9	579	324.8	97.3	55.9	56.8	318.4	100.4	54.8	53.6	307.9	105.6	53.0	50.1	296.6	111.3	51.0	46.5	288.6	115.5	49.7	44.1	275.9	122.3	47.5	40.3	262.3	129.7	45.1	36.4
	300	374.1	109.6	64.4	560	366.6	113.0	63.1	53.8	358.7	116.7	61.7	51.5	346.1	122.8	59.5	48.0	332.7	129.6	57.2	44.3	323.3	134.5	55.6	41.9	308.5	142.4	53.1	38.1	292.8	151.0	50.4	34.4
	340	419.4	131.3	72.2	478	411.1	135.5	70.7	45.9	402.2	140.1	69.2	43.9	387.5	147.7	66.7	40.8	371.5	156.3	63.9	37.5	359.9	162.5	61.9	35.2	341.5	172.6	58.7	31.7	-	-	-	-
10 °C	200	466.7	134.1	80.3	482	457.6	138.3	78.7	46.4	447.9	142.8	77.1	44.5	432.5	150.2	74.4	41.5	415.9	158.5	71.6	38.4	404.3	164.5	69.6	36.3	385.9	174.2	66.4	33.1	366.3	184.7	63.0	29.8
	230	509.8	152.8	87.7	575	500.3	157.5	86.1	55.4	490.2	162.7	84.3	53.2	473.6	171.3	81.5	49.7	455.4	181.1	78.3	46.0	442.3	188.1	76.1	43.4	421.4	199.6	72.5	39.4	398.9	212.2	68.6	35.3
	270	539.6	163.3	94.2	402	534.7	165.4	93.6	40.8	529.6	170.9	91.5	48.9	518.6	180.9	89.6	46.1	503.6	191.9	87.0	43.2	488.6	199.9	85.1	40.5	473.6	211.9	82.0	37.4	458.6	225.9	73.6	60.0
	300	581.1	171.3	101.1	467	579.6	176.3	100.0	48.9	568.6	181.8	99.9	47.8	557.6	192.9	97.9	45.8	540.6	204.9	94.8	43.1	529.6	209.9	92.9	40.4	514.6	222.9	88.9	35.4	494.6	231.9	78.6	66.0
	340	623.1	181.3	108.1	467	623.1	181.3	108.1	46.7	623.1	181.3	108.1	46.7	623.1	181.3	108.1	46.7	623.1	181.3	108.1	46.7	623.1	181.3	108.1	46.7	623.1	181.3	108.1	46.7	623.1	181.3	108.1	46.7

XXX : Data according to Eurovent standard conditions	Pf : Net cooling capacity in kW	Pe : Effective absorbed power in cooling mode	Wf : Water flow in m³ per hour	Dp : Water pressure drop in KPa
--	---	---	--	---

NAH		Air inlet temperature																																															
		28 °C						30 °C						32 °C						35 °C						38 °C						40 °C						43 °C						46 °C					
		Pc	Pe	Wf	Dp	Pc	Pe	Wf	Dp	Pc	Pe	Wf	Dp	Pc	Pe	Wf	Dp	Pc	Pe	Wf	Dp	Pc	Pe	Wf	Dp	Pc	Pe	Wf	Dp	Pc	Pe	Wf	Dp	Pc	Pe	Wf	Dp												
Cooling mode		kW		m³/h		kPa		kW		m³/h		kPa		kW		m³/h		kPa		kW		m³/h		kPa		kW		m³/h		kPa		kW		m³/h		kPa													
Water outlet temperature	5°C	200	194,5	60,2	33,5	26,6	190,2	62,4	32,7	25,4	185,8	64,8	32,0	24,2	179,0	68,4	30,8	22,5	171,9	72,3	29,6	20,8	167,1	75,1	28,7	19,6	159,6	79,4	27,5	17,9	151,9	83,9	26,1	16,2															
		230	218,2	73,2	37,5	33,4	213,7	75,9	36,8	32,0	208,9	78,8	35,9	30,6	201,5	83,3	34,7	28,5	193,5	88,2	33,3	26,3	187,9	91,6	32,3	24,8	179,2	97,0	30,8	22,6	170,0	102,7	29,2	20,3															
		270	275,3	84,6	47,4	40,1	269,7	87,5	46,4	38,5	263,8	90,6	45,4	36,8	254,5	95,6	43,8	34,3	244,7	101,1	42,1	31,7	237,9	105,0	40,9	30,0	227,1	111,3	39,1	27,3	215,8	118,0	37,1	24,7															
		300	299,6	96,9	51,5	47,5	293,7	100,3	50,5	45,6	287,6	104,0	49,5	43,8	277,6	109,9	47,8	40,8	266,9	116,4	45,9	37,7	259,3	121,0	44,6	35,6	247,3	128,5	42,5	32,4	234,5	136,5	40,3	29,1															
	6°C	200	201,0	60,8	34,6	28,4	196,6	63,0	33,8	27,1	192,1	65,3	33,0	25,9	185,1	68,9	31,8	24,1	177,8	72,8	30,6	22,2	172,9	75,6	29,7	21,0	165,2	79,9	28,4	19,2	157,3	84,4	27,1	17,4															
		230	225,6	74,0	38,8	35,7	220,9	76,7	38,0	34,2	216,1	79,5	37,2	32,7	208,4	84,0	35,8	30,5	200,2	88,9	34,4	28,1	194,5	92,3	33,5	26,6	185,6	97,6	31,9	24,2	176,2	103,3	30,3	21,8															
		270	284,0	85,3	48,9	42,7	278,2	88,2	47,9	41,0	272,2	91,3	46,8	39,2	262,7	96,3	45,2	36,5	252,6	101,7	43,5	33,8	245,5	105,6	42,2	31,9	234,5	111,9	40,3	29,1	222,9	118,6	38,4	26,4															
		300	309,1	97,9	53,2	50,5	303,1	101,2	52,1	48,6	296,7	104,8	51,0	46,6	286,5	110,7	49,3	43,4	275,5	117,1	47,4	40,2	267,7	121,7	46,1	37,9	255,4	129,1	43,9	34,5	242,3	137,0	41,7	31,1															
	7°C	200	207,6	61,3	35,7	30,2	203,0	63,5	34,9	28,9	198,4	65,8	34,1	27,6	191,2	69,5	32,9	25,7	183,8	73,4	31,6	23,7	178,7	76,1	30,7	22,4	170,9	80,4	29,4	20,5	162,8	84,9	28,0	18,6															
		230	232,9	74,8	40,1	38,0	228,1	77,5	39,3	36,5	223,1	80,3	38,4	34,9	215,3	84,8	37,0	32,5	206,9	89,5	35,6	30,0	201,1	92,9	34,6	28,4	191,9	98,2	33,0	25,9	182,3	103,8	31,4	23,4															
		270	292,8	86,1	50,4	45,4	286,9	88,9	49,4	43,5	280,6	92,0	48,3	41,7	270,9	96,9	46,6	38,8	260,5	102,4	44,8	35,9	253,3	106,2	43,6	34,0	242,0	112,5	41,6	31,0	230,2	119,1	39,6	28,1															
		300	318,6	96,8	54,8	53,7	312,4	102,1	53,8	51,6	305,9	105,7	52,6	49,5	295,4	111,5	50,8	46,2	284,1	117,9	48,9	42,7	276,2	122,4	47,5	40,4	263,6	129,8	45,3	36,8	250,2	137,6	43,0	33,2															
8°C	200	214,1	61,9	36,8	32,1	209,4	64,1	36,0	30,8	204,7	66,4	35,2	29,4	197,3	70,0	33,9	27,3	189,7	73,9	32,6	25,3	184,5	76,6	31,7	23,9	176,5	80,9	30,4	21,9	168,2	85,4	28,9	19,9																
	230	240,2	75,7	41,3	40,4	235,3	78,3	40,5	38,8	230,2	81,1	39,6	37,1	222,1	85,5	38,2	34,6	213,5	90,2	36,7	32,0	207,6	93,5	35,7	30,2	198,3	98,8	34,1	27,6	188,5	104,4	32,4	24,9																
	270	301,7	86,8	51,9	48,2	295,6	89,6	50,9	46,2	289,2	92,6	49,8	44,2	279,1	97,6	48,0	41,2	268,5	103,0	46,2	38,2	261,1	106,9	44,9	36,1	249,6	113,1	42,9	33,0	237,5	119,7	40,9	29,9																
	300	328,3	99,8	56,5	57,0	321,9	103,1	55,4	54,8	315,2	106,6	54,2	52,5	304,4	112,3	52,4	49,0	292,8	118,6	50,4	45,4	284,7	123,2	49,0	42,9	271,8	130,4	46,8	39,1	258,1	138,2	44,4	35,3																
10°C	200	227,2	63,0	39,1	36,2	222,3	65,2	38,2	34,6	217,3	67,5	37,4	33,1	209,6	71,1	36,1	30,8	201,6	74,9	34,7	28,5	196,1	77,6	33,7	27,0	187,8	81,9	32,3	24,8	179,1	86,4	30,8	22,5																
	230	254,8	77,3	43,8	45,4	249,6	79,9	42,9	43,6	244,2	82,6	42,0	41,7	235,7	86,9	40,6	38,9	226,8	91,5	39,0	36,0	220,5	94,8	37,9	34,1	210,8	100,0	36,3	31,2	200,6	105,5	34,5	28,2																
	270	319,8	86,3	55,0	54,1	313,3	91,1	53,9	51,9	306,6	94,1	52,7	49,7	296,0	99,0	50,9	46,3	284,8	104,3	49,0	42,9	277,1	108,1	47,7	40,6	265,0	114,3	45,6	37,2	252,4	120,9	43,4	33,7																
	300	347,7	101,7	59,8	63,9	341,0	104,9	58,7	61,4	333,9	108,4	57,4	58,9	322,5	114,0	55,5	55,0	310,4	120,2	53,4	51,0	301,9	124,6	51,9	48,2	288,4	131,8	49,6	44,0	274,2	139,5	47,2	39,8																

XXX : Data according to Eurovent standard conditions	Pf : Net cooling capacity in kW	Pe : Effective absorbed power in cooling mode	Wf : Water flow in m³ per hour	Dp : Water pressure drop in KPa
--	---	---	--	---

NAH		Outdoor air temperature																																																																																										
		10 °C						7 °C						0 °C						-6 °C						-10 °C																																																																		
		Pc	Pe	Wf	Dp	Pc	Pe	Wf	Dp	Pc	Pe	Wf	Dp	Pc	Pe	Wf	Dp	Pc	Pe	Wf	Dp	Pc	Pe	Wf	Dp																																																																			
kW	kW	m³/h	kPa	kW	kW	m³/h	kPa	kW	kW	m³/h	kPa	kW	kW	m³/h	kPa	kW	kW	m³/h	kPa	kW	kW	m³/h	kPa																																																																					
Heating mode																																																																																												
Water outlet temperature	30 °C	200	250,7	52,2	43,1	44,0	37,6	192,3	51,0	33,1	26,0	164,0	50,2	28,2	18,9	148,0	49,7	25,5	15,4	230	284,6	61,5	49,0	56,6	263,2	61,0	45,3	48,5	218,5	59,9	37,6	33,5	186,2	59,0	32,0	24,3	167,6	58,3	28,8	19,8	270	357,9	75,8	61,6	67,6	330,6	75,0	56,9	57,8	273,8	73,3	47,1	39,7	232,7	72,0	40,0	28,7	209,2	71,2	36,0	23,2	300	392,8	85,2	67,6	81,4	363,0	84,2	62,4	69,6	300,8	82,3	51,7	47,8	255,5	80,8	44,0	34,6	229,5	80,0	39,5	27,9										
		35 °C	200	245,7	56,9	42,3	42,3	227,3	36,2	189,3	55,4	32,6	25,2	162,2	54,4	27,9	18,5	146,9	53,8	25,3	15,2	230	280,5	66,9	48,3	55,0	259,7	66,4	44,7	47,2	216,3	65,1	37,2	32,8	185,2	64,0	31,9	24,1	167,4	63,3	28,8	19,7	270	350,6	82,2	60,3	64,9	324,2	81,4	55,8	55,6	269,6	79,7	46,4	38,5	230,4	78,4	39,6	28,1	208,1	77,7	35,8	23,0	300	386,4	92,4	66,5	78,8	357,5	91,5	61,5	67,5	297,5	89,6	51,2	46,8	254,1	88,2	43,7	34,2	229,3	87,4	39,4	27,9								
			38 °C	200	242,8	60,1	41,8	41,3	224,7	35,4	187,5	58,4	32,3	24,7	161,1	57,4	27,7	18,3	146,3	56,6	25,2	15,1	230	277,9	70,7	47,8	54,0	257,4	70,1	44,3	46,4	214,9	68,8	37,0	32,4	184,4	67,6	31,7	23,9	167,2	66,8	28,8	19,7	270	346,3	86,7	59,6	63,4	320,5	85,9	55,1	54,3	267,1	84,2	46,0	37,8	229,0	83,0	39,4	27,8	207,5	82,2	35,7	22,8	300	382,4	97,4	65,8	77,2	354,1	96,6	60,9	66,3	295,3	94,7	50,8	46,1	253,0	93,4	43,5	33,9	229,0	92,6	39,4	27,8							
	40 °C			200	240,8	62,4	41,4	40,6	223,0	34,9	186,4	60,6	32,1	24,4	160,4	59,5	27,6	18,1	145,9	58,7	25,1	15,0	230	276,2	73,5	47,5	53,3	255,9	72,8	44,0	45,8	214,0	71,4	36,8	32,1	183,9	70,2	31,6	23,8	-	-	-	-	270	343,4	89,9	59,1	62,3	318,0	89,1	54,7	53,5	265,5	87,5	45,7	37,3	228,1	86,2	39,2	27,6	207,1	85,5	35,6	22,8	300	379,7	101,2	65,3	76,1	351,8	100,3	60,5	65,4	293,9	98,5	50,6	45,7	252,3	97,2	43,4	33,7	228,7	96,4	39,4	27,7							
		42 °C		200	238,9	64,8	41,1	40,0	221,3	34,3	185,2	62,9	31,9	24,1	159,8	61,7	27,5	18,0	145,0	58,7	25,1	15,0	230	274,4	76,4	47,2	52,6	254,4	75,7	43,8	45,3	212,9	74,2	36,6	31,8	183,4	72,9	31,6	23,6	-	-	-	-	270	340,5	93,4	58,6	61,3	315,5	92,6	54,3	52,6	263,9	90,9	45,4	36,9	227,3	89,7	39,1	27,4	-	-	-	-	300	376,9	105,1	64,8	75,0	349,4	104,3	60,1	64,5	292,3	102,5	50,3	45,2	251,5	101,2	43,3	33,5	-	-	-	-							
			45 °C	200	236,1	68,7	40,6	39,0	218,9	33,6	183,6	66,6	31,6	23,7	158,8	65,3	27,3	17,7	145,0	58,7	25,1	15,0	230	271,6	81,1	46,7	51,6	251,9	80,4	43,3	44,4	211,3	78,8	36,4	31,3	-	-	-	-	-	-	-	-	270	336,3	99,0	57,9	59,8	312,5	97,7	53,6	51,4	261,5	96,5	45,0	36,2	226,0	95,3	38,9	27,1	-	-	-	-	300	372,6	111,6	64,1	73,3	345,6	110,7	59,5	63,1	289,9	109,0	49,9	44,5	-	-	-	-	-	-	-	-	-	-					
	48 °C			200	233,3	72,9	40,1	38,1	216,4	32,8	182,0	70,6	31,3	23,3	-	-	-	-	-	-	-	-	230	268,8	86,1	46,2	50,5	249,5	85,4	42,9	43,6	209,7	83,7	36,1	30,8	-	-	-	-	-	-	-	-	270	332,1	105,0	57,1	58,3	308,1	104,3	53,0	50,2	259,1	102,6	44,6	35,6	-	-	-	-	-	-	-	-	-	-	300	368,2	118,6	63,4	71,6	341,8	117,8	58,8	61,7	287,3	116,1	49,4	43,7	-	-	-	-	-	-	-	-	-	-	-		
		50 °C		200	231,5	75,8	39,8	37,5	214,8	32,4	180,9	73,4	31,1	23,0	-	-	-	-	-	-	-	-	230	266,9	89,7	45,9	49,8	247,8	89,0	42,6	43,0	208,5	87,2	35,9	30,5	-	-	-	-	-	-	-	-	-	-	270	329,3	109,3	56,6	57,3	305,7	108,6	52,6	49,4	257,6	107,0	44,3	35,1	-	-	-	-	-	-	-	-	-	-	-	300	365,2	123,6	62,8	70,5	339,2	122,8	58,4	60,8	285,6	121,2	49,1	43,2	-	-	-	-	-	-	-	-	-	-

Pc :
Net heating capacity in kW

Pe :
Effective absorbed power in heating mode

Wf :
Water flow in m³ per hour

Dp :
Water pressure drop in KPa

**NAC 200 / 230 / 270
NAH 200 / 230**

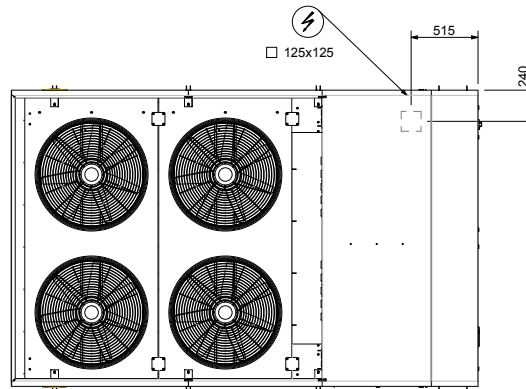
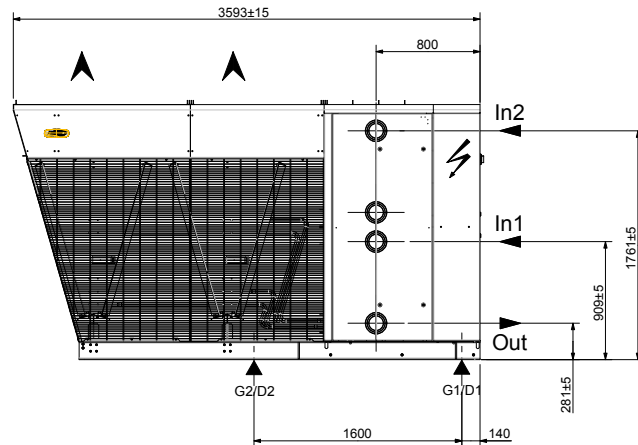
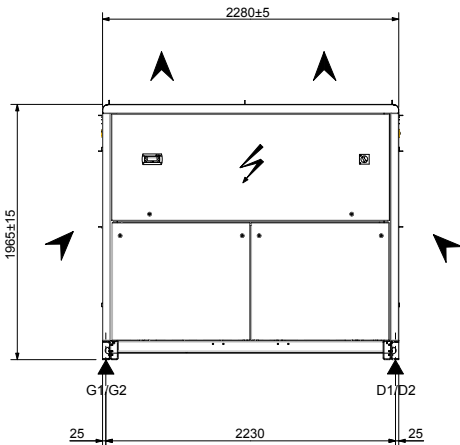

LOAD SITRIBUTION
(Kg - Operating weights)

	G1	G2	D1	D2
NAC 200	Please consult us			
NAC 230				
NAC 270				
NAH 200				
NAH 230				

CLEARANCES

Overhead obstruction are not permitted

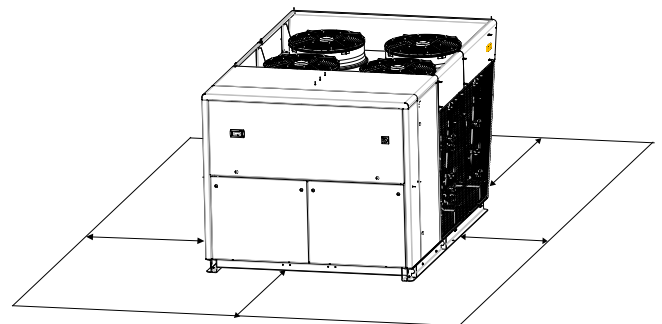

Lennox recommend load distribution as detailed above,

**NAC 300
NAH 270 / 300**

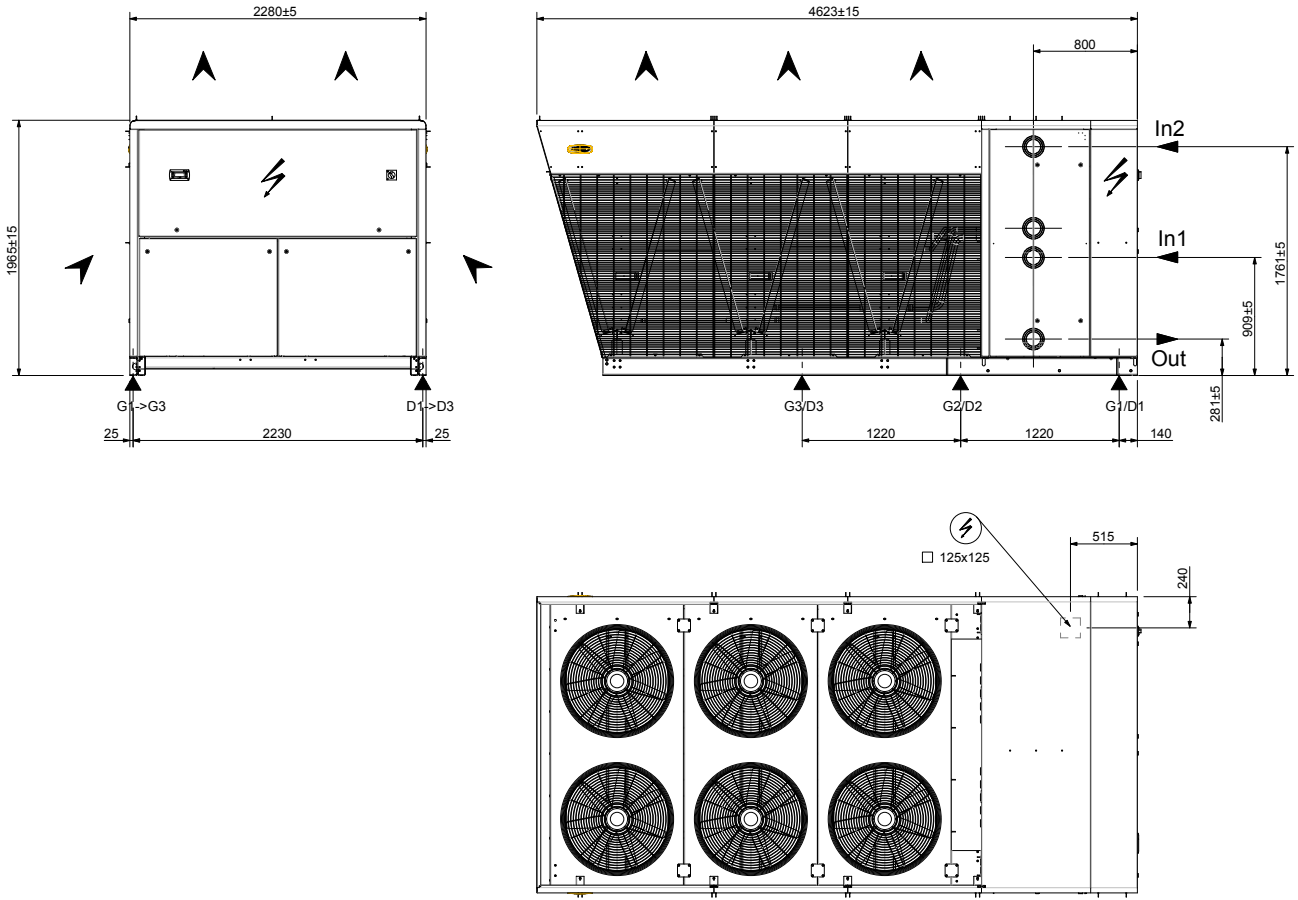

LOAD SITRIBUTION
(Kg - Operating weights)

	G1	G2	G3	D1	D2	D3
NAC 300	Please consult us					
NAH 270						
NAH 300						

CLEARANCES

Overhead obstruction are not permitted

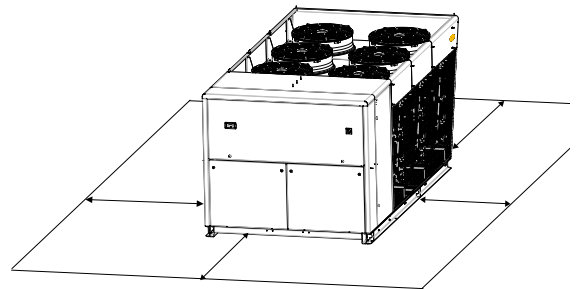

NAC 340 / 380

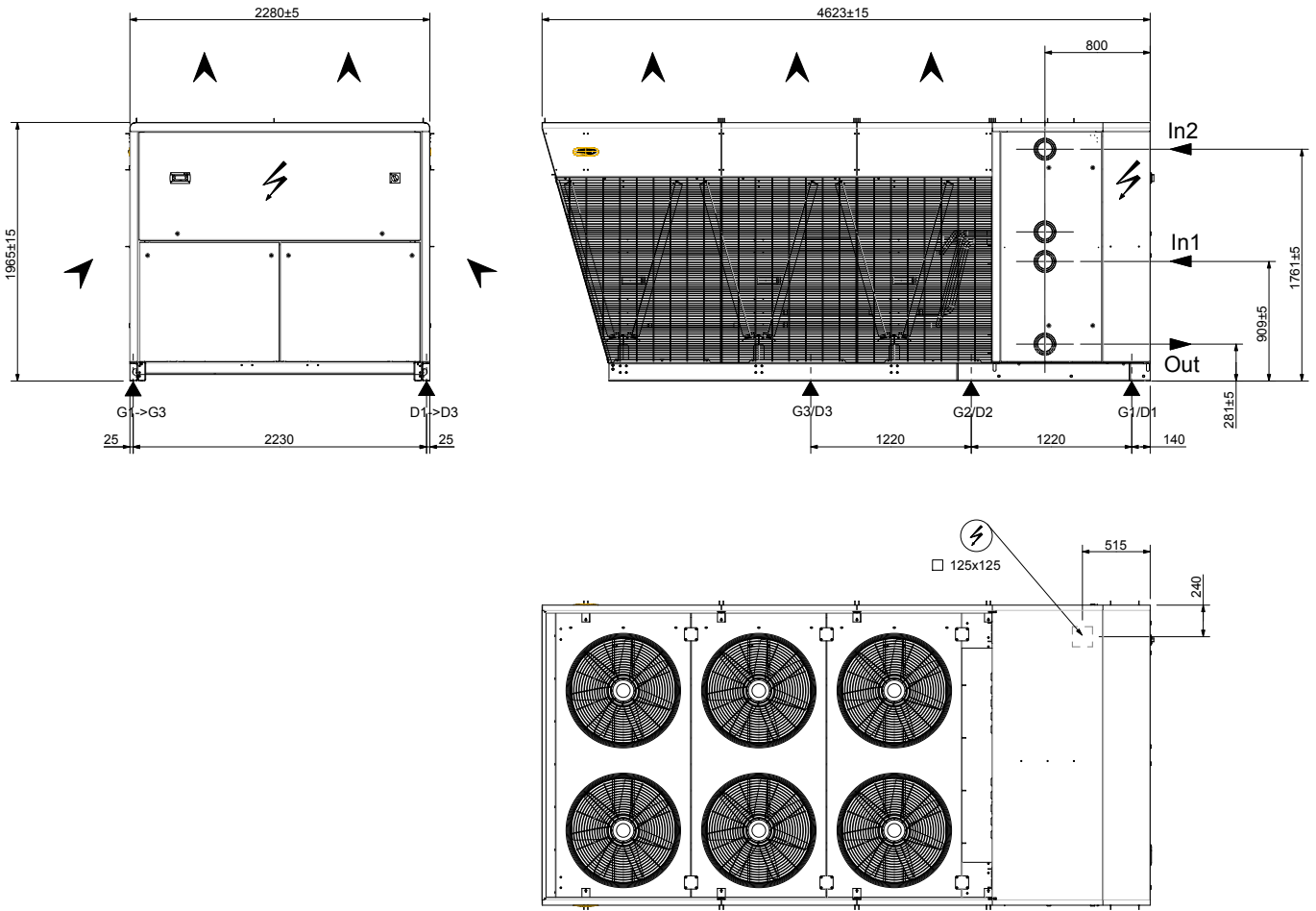

LOAD SITRIBUTION
(Kg - Operating weights)

	G1	G2	G3	D1	D2	D3
NAC 340	Please consult us					
NAC 340						

CLEARANCES

Overhead obstruction are not permitted

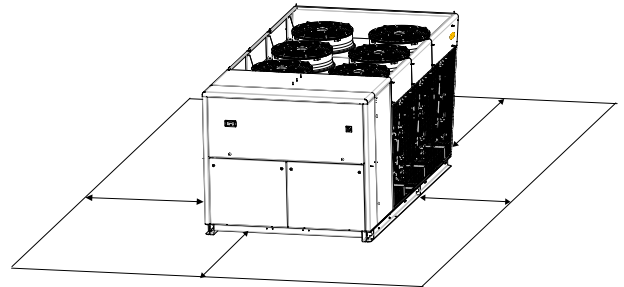

NAC 420 / 480

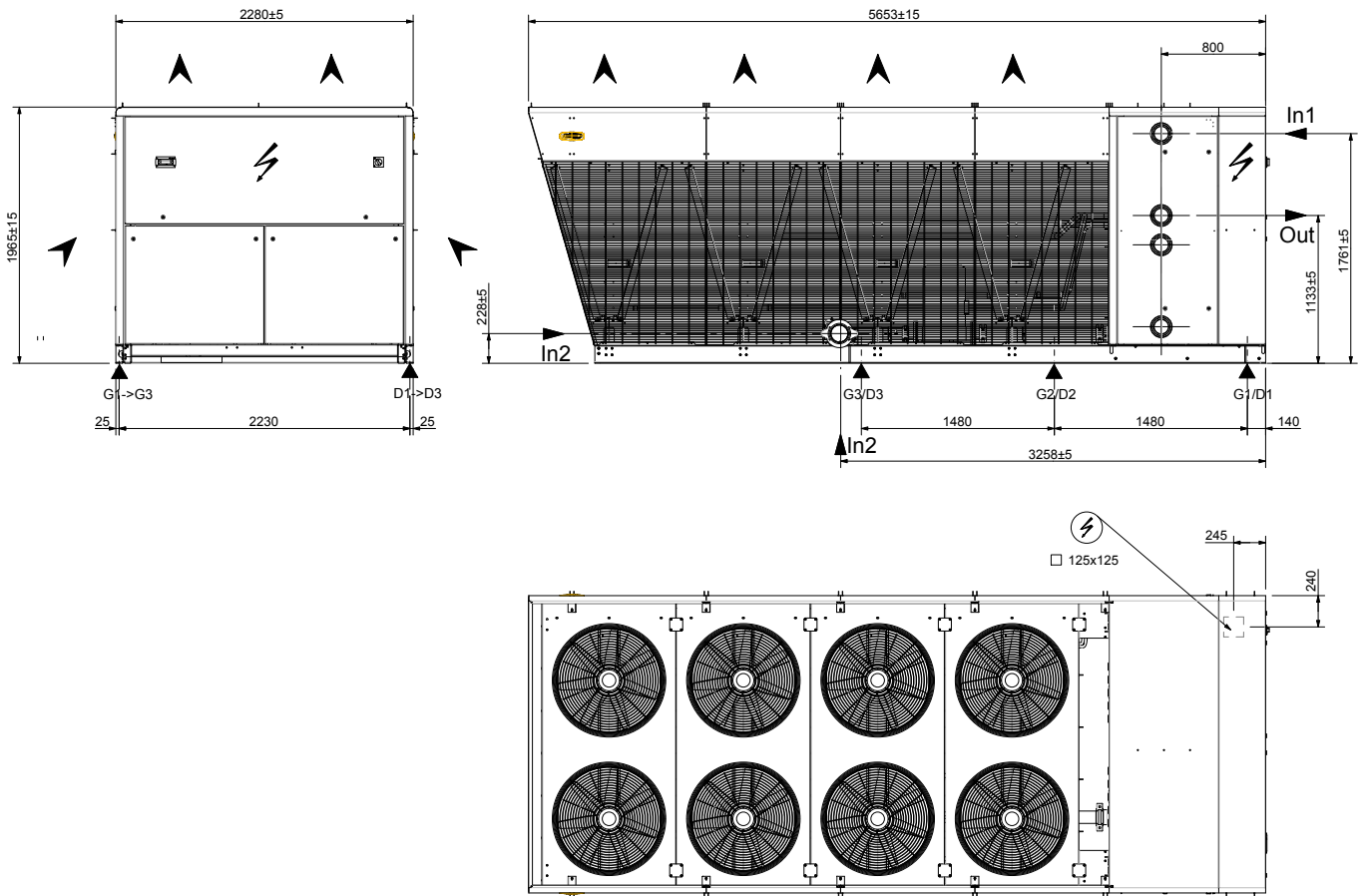

LOAD SITRIBUTION
(Kg - Operating weights)

	G1	G2	G3	D1	D2	D3
NAC 420	Please consult us					
NAC 480						

CLEARANCES
Overhead obstruction are not permitted

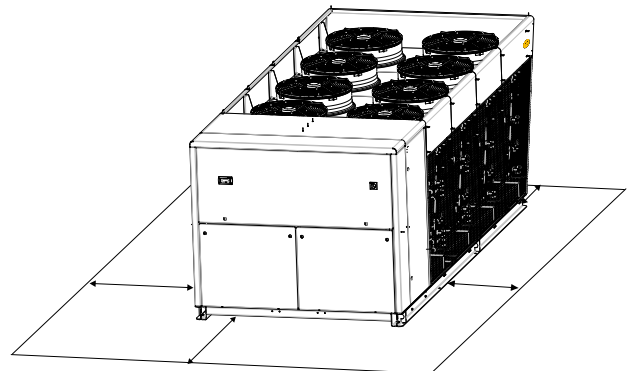

NAC

	NAC	200	230	270	300	340	380	420	480
Without hydraulic module									
Operating weight	kg	Please consult us							
Shipping weight	kg	2246	2272	2520	2877	3147	3184	3704	3782
With LP single pump									
Operating weight	kg	Please consult us							
Shipping weight	kg	2382	2455	2631	2980	3249	3434	3865	3943
With LP double pump									
Operating weight	kg	Please consult us							
Shipping weight	kg	2412	2487	2669	3024	3293	3509	3940	4018
With HP single pump									
Operating weight	kg	Please consult us							
Shipping weight	kg	2391	2493	2669	3020	3289	3442	3876	3954
With HP double pump									
Operating weight	kg	Please consult us							
Shipping weight	kg	2430	2565	2745	3104	3373	3526	3972	4050

NAH

	NAC	200	230	270	300
Without hydraulic module					
Operating weight	kg	Please consult us			
Shipping weight	kg	Please consult us			
With single pump					
Operating weight	kg	Please consult us			
Shipping weight	kg	Please consult us			
With double pump					
Operating weight	kg	Please consult us			
Shipping weight	kg	Please consult us			
With LP single pump					
Operating weight	kg	Please consult us			
Shipping weight	kg	Please consult us			
With HP double pump					
Operating weight	kg	Please consult us			
Shipping weight	kg	Please consult us			

GENERAL CHARACTERISTICS OF THE UNIT

The NEOSYS unit is designed to be integrated into urban or residential environments.

As main characteristics the NEOSYS unit offers **state of the art design** to match architectural constraints and **adjustable sound level performances** during day and night to satisfy local environmental constraints.

CASING/CHASSIS

- Casing made of galvanised steel sheet metal painted with a white RAL 9002 powdered polyester paint and a RAL3003 red stripe.
- Fully RAL 7016 grey colour painted chassis protecting against corrosion.
- **State of the art design** with hidden compressors, fans and pump for perfect architectural integration.
- Flat top, aesthetic grilles, **very low unit height (< 2m)** for discrete installation on a roof reducing the requirement of costly cladding solutions around the unit
- **Aesthetic anti-intrusion grilles** as standard to protect the unit during transportation and against human aggressions.

COMPRESSOR

- Exclusive Compliant Scroll® design with both axial and radial compliance to increase compressor operation tolerance to liquid refrigerant, substantially improving durability and reliability. **3-year warranty (to be confirmed)**.
- Motor cooled by suction gas.
- Electronic control of the compressor discharge temperature.
- Motor protection device against high temperature or over current situations.
- Discharge non-return valve.
- Low noise scroll compressors mounted in a sound-proofed technical cabinet to reduce noise emissions.
- Compressors assembly installed on an independent chassis supported by anti-vibration mountings.

WATER HEAT EXCHANGER

- True dual circuit plate heat exchanger
- Copper brazed Stainless steel plate heat exchanger.
- 13 mm thermal insulation foam.
- Water heat exchanger located in a technical cabinet protecting the insulation against climatic conditions (UV light, rain).

AIR HEAT EXCHANGER

- High efficiency aluminium Micro Channel heat exchangers (MCHX) with improved corrosion resistance in moderate marine or urban environment (cooling only version). **3-year warranty**.
- Standard copper tubes/aluminium fins heat exchanger (heat pump version).
- V-coil design to protect the unit against climatic conditions (e.g. hail).

FANS

- Variable speed driven fans (0 to 900 rpm operating range).
- **Active Acoustic Attenuation System™** to meet changing building load requirements while automatically adjusting the air flow to respect night and day sound level constraints (adjustable setting over time schedule with 4 time zones per day).
- Elimination of intrusive start/stop noise that is irritating to the human ear.
- Fan-motor assembly using external rotor technology associated with Shark™ high performance aluminium fan blades of the latest generation.
- IP 54 electrical motor, class F protected against high temperature with an internal sensor.
- Exclusive fan design with hybrid Ceramic bearings to extend the service life of motors and to reduce noise level. With these sealed hybrid ceramic bearings, our customer can expect little or no maintenance of the motor throughout its life. **3-year warranty**.
- Extremely rigid fan assembly via the integration of the fans mounted within a pre-formed bell mouth roof panel, thus improving rigidity while reducing vibrations.
- Rounded top acoterion panels to hide the fans and reduce noise emissions for quieter operation.

REFRIGERANT CIRCUIT

NEOSYS is using R410A refrigerant in 2 independent circuits. Each circuit includes:

- **A refrigerant charge reduced by 30%** due to the use of R410A combined with micro channel heat exchanger (NAC/Cooling only version).
- Suction piping with thermal insulation.
- Filter drier with removable cartridge filter.
- Thermostatic or electronic expansion valve (Electronic device only when "winter operation" option selected).
- Temperature sensors and pressure transducers.
- Four-way valve and liquid receiver (heat pump units only).
- Leak-tight refrigerant circuit with brazing carried out under nitrogen by certified engineers.
- Each refrigerant circuit is pressure and leak tested with a Hydrogen/Nitrogen mixture, and vacuumed before being charged with refrigerant. All units are then subjected to a complete functional and operational run test to guarantee perfect sealing before leaving the factory.

ELECTRICAL BOX

- Unit electrical cabinet, components and wiring in compliance with EN 60204-1 electrical directive.
- 400V, 50 Hz, 3 phase power supply (without neutral) with a single point of power connection.
- Bottom entry (through the base) for electrical power.
- IP54 protection class.
- **Air spring powered Butterfly Electrical Panel™** with top opening providing protection to the service engineers against rain or snow during commissioning and maintenance operations.
- Recognized brand electrical components (Schneider) for ease of maintenance.
- Main on/off switch mounted on the front panel.
- DC50™ user interface mounted on the front panel.
- Main disconnect switch with high trip capacity allowing optimized sizing of the customer power supply.
- 400/24 V transformer to supply the control circuit.
- Numbered electrical wires to facilitate maintenance and diagnostic.
- Variable Frequency Drives (VFD) to control the fan speed.

CONTROL

CLIMATIC™ microprocessor based control is providing the following functions:

- 4 scheduling time zones per day over 7 days to allow energy consumption and sound level management according to the building use and environmental constraints.
- PI control of the water temperature with operating time equalisation of the compressors.
- Water set-point offset based on outdoor air temperature (BE50™ option needed).
- **Active variable speed control of all fans** to optimize the unit condensing pressure and energy performances at full- and part-load while meeting authorized maximum noise level in the time zone (Active Acoustic Attenuation System™ control patented).
- Intelligent advanced control algorithm to protect the compressors against excessive short-cycling and to allow **operation of the unit without buffer tank** in most comfort air conditioning applications (e.g. unit with fan-coils). Refer to minimum installation water loop volume recommendations.
- **Dynamic defrost** to limit the number and the duration of the defrost cycles in winter for high performance of the unit (Dynamic Defrost patented).
- Automatic compressor unloading in case of excessive condensating pressure allowing the operation of the machine at high outdoor air temperature (operation extended up to 46°C ambient).
- Water pump control with operating time equalization and automatic change-over in case of a pump fault (Twin pump only).
- Master/slave or cascade control of two chillers operating in parallel with operating time equalization and automatic change-over in case of a unit fault.

CLIMATIC™ is pre-factory configured with default settings allowing a fast commissioning on site. The DC50™ user interface with graphical display is easy to use, intuitive. Main

customer parameters can be read or modified without main power shut-off (Entering/leaving water temperatures, outdoor air temperature, alarm history, scheduling of the different time zone, water and noise level set-points, high and low pressures reading...).

The DS50™ service display (optional) is a “plug and play” controller that allows service people to read and modify all unit parameters (Unit settings, operating time and number of compressor starts, low and high pressure reading, read the history of last 32 faults...).

COMMUNICATION

The control board is equipped with a RS485 serial communication port to allow remote management through communication bus. According to the wished communication protocol, our control board can be fitted with ModBUS®, **LonWorks® or BacNET® communication interface** (options).

The main control board has free dry contacts that allow remote control of the unit by wired cable:

- Remote on/off of the unit.
- Remote alarm reset to re-start the unit.
- Alarm or alert indications.
- Free customer contact.
- Force Ventilation at 100%.

With the optional extension board BE50™, it is possible to get additional customized digital or analog inputs / outputs for remote control of the unit:

- Fault fans or pumps (dry contact).
- Operation indication at 100% on circuit 1 or 2 (dry contact).
- Dual water set-point management (dry contact).
- Force heating or cooling mode (24V AC input).
- Power limitation by disabling circuit 1 or 2 (24V AC input).
- Force unoccupied mode (24V AC input).
- Water set-point offset based on outdoor air temperature (4-20mA input). Note: non available with heat-pump units.

DIRECTIVES

The unit is built to meet European norms and standards & Eurovent certification performance standards.

- DI 97/23/CE Pressure Equipment Directive.
- DI 98/37/CE Machinery Directive.
- DI 73/23/CE Low Voltage Directive.
- DI 89/336/CE Electro Magnetic Compatibility Directive
- EN 378-2 Safety and Environmental Directive. (Non utilisée sur notre déclaration CE)
- **The European Restriction of the Use of Certain Hazardous Substances (RoHS).**

EXAMPLE : NAC 200D N M1 M

N	NEOSYS
A	Air cooled
C	Cooling
200	Cooling capacity in kW
D	Number of circuits : S = 1 circuit D = 2 circuits T = 3 circuits F = 4 circuits
N	Non ducted
M	R410 A refrigerant
1	Revision number
M	400V/3/50 Hz