

INSTALLATION OPERATING & MAINTENANCE MANUAL



PROVIDING **GLOBAL SYSTEM SOLUTIONS**

ECOLEAN
EAC/EAR

English
1003

TABLE OF CONTENTS

PREFACE	PAGE 2
DATA PAGE FOR UNIT COMMISSIONING	PAGE 3
1.- GENERAL CHARACTERISTICS	PAGE
1.1.- TECHNICAL DATA	4-5
1.2.- ELECTRICAL DATA	6-8
1.3.- COMPONENT	9
1.4.- OPERATION LIMITS	10-11
1.5.- PRESSURE DROP IN THE WATER SYSTEM	12-13
1.6.- HYDRAULIC SYSTEM DATA	14
1.7.- SAFETY DEVICES	15-16
1.8.- PIPING DRAWINGS	17-20
1.9.- DIMENSIONS	21-24
1.10.- OPTIONS	25-26
2.- INSTALLATION	PAGE
2.1.- SITE AND SHIPPING GUIDANCE	27
2.2.- UNIT LIFTING	27
2.3.- ANTIVIBRATION MOUNTING	28
2.4.- INSTALLATION CLEARANCES	29
2.5.- UNIT INSTALLATION	30-31
2.6.- ELECTRICAL CONNECTIONS	32
3.- COMMISSIONING AND OPERATION	PAGE
3.1.- STEPS TO FOLLOW FOR COMMISSIONING THE UNITS	33
3.2.- CHECKING THE WATER FLOW RATE	34
3.3.- CORROSION RESISTANCE OF COPPER AND STAINLESS STEEL OF PLATES EXCHANGER	35
4.- MAINTENANCE	PAGE
4.1.- PREVENTIVE MAINTENANCE	36
4.2.- CORRECTIVE MAINTENANCE	37
4.3.- FAILURE DIAGNOSIS	38

Our company is a member of the Eurovent Certification Programme. The EcoLean™ range of Lennox chillers are tested and rated in accordance with the Eurovent certification program.



Our company's products comply with European standards.



The manufacturing of EcoLean™ answers to ISO9001 control quality system.



Lennox have been providing environmental solutions since 1895, our range of EcoLean™ reversible chillers continues to meet the standards that have made LENNOX a household name. Flexible design solutions to meet YOUR needs and uncompromising attention to detail. Engineered to last, simple to maintain and Quality that comes as standard. Information on local contacts at www.lennox europe.com.

All the technical and technological information contained in this manual, including any drawing and technical descriptions provided by us, remain the property of Lennox and must not be utilised (except in the operation of this product), reproduced, issued to or made available to third parties without the prior written agreement of Lennox.

The specifications and technical characteristics in this booklet are given for information purposes. The manufacturer reserves the right to modify them without prior notice or obligation to modify in a similar manner, the equipments previously supplied.

Please read this operating manual prior to commissioning the EcoLean™ chiller. Familiarize yourself with the operation and control of the EcoLean™ chiller and closely follow the instructions. We would like to stress the importance of training with respect to the correct handling of the chiller. Please consult Lennox on the options available in this field. It is important that this manual be stored in a permanent location in the vicinity of the EcoLean™ chiller. For the sake of clarity, important items in this manual are shown as follows:

Text	Important general instructions
	Danger of damage to the chiller

This manual contains important instructions regarding the commissioning of the EcoLean™ chiller. It also includes important instructions to prevent personal injury and damage to the machine during operation. Furthermore, in order to promote fault-free operation of the chiller, maintenance information has been included.

Please do not hesitate to contact one of our employees should you require further information on specific chiller subjects.

Order related documentation will be forwarded under separate cover. This documentation consists of:

- **CE declaration**
- **Operating manual for control system**
- **Installation Operating manual**
- **Wiring diagram**
- **Unit detail are given on unit nameplate**

FOR NETHERLAND: the STEK logbook, including the required certificates will be handed over by the installation technician or left with the machine following commissioning by Lennox. The data published in this manual is based on the most recent information available. It is supplied conditional to later modifications. We reserve the right to modify the construction and/or design of our EcoLean™ chillers, at any time, without prior notification or obligation to adapt previous supplies accordingly.

Any work on the Chiller should be carried out by trained and licensed competent technician. The following risks are present on the unit:

- **risk of electrical shock**
- **risk of injury from rotating parts**
- **risk of injury from sharp edges and heavy weight**
- **risk of injury from high pressure gas**
- **risk of injury from high and low temperatures components**

DATA PAGE FOR UNIT COMMISSIONING

UNIT: _____ SERIAL No.: _____

CONTROL PANEL IDENTIFICATION CODE _____

INSTALLATION ADDRESS: _____

INSTALLER: _____ INSTALLER TEL.: _____

INSTALLER ADDRESS: _____

DATE OF COMMISSIONING: _____

CHECKS:

SUPPLY VOLTAGE: _____ RATED VOLTAGE OF THE UNIT: _____

	YES	NO
UNIT ON RUBBER ANTIVIBRATION MOUNTS	<input type="checkbox"/>	<input type="checkbox"/>
GENERAL POWER SUPPLY CONNECTION	<input type="checkbox"/>	<input type="checkbox"/>
CONTROL PANEL CONNECTION (OPTION)	<input type="checkbox"/>	<input type="checkbox"/>
COMPRESSOR OIL LEVEL INDICATOR	<input type="checkbox"/>	<input type="checkbox"/>
HYDRAULIC CONNECTION	<input type="checkbox"/>	<input type="checkbox"/>
PURGED OF THE INSTALLATION	<input type="checkbox"/>	<input type="checkbox"/>

DATA INPUT:

COOLING CYCLE

Air Input Temperature, Coil: _____ °C
 Water Output Temperature: _____ °C
 Water Input Temperature: _____ °C
 High Pressure: _____
 Low Pressure: _____

HEATING CYCLE

Air Input Temperature, Coil: _____ °C
 Water Output Temperature: _____ °C
 Water Input Temperature: _____ °C
 High Pressure: _____
 Low Pressure: _____

ELECTRIC POWER CONSUMPTION (Amp.)

Compressor 1 _____/_____/_____
 Fan 1 _____/_____/_____
 Compressor 2 _____/_____/_____
 Fan 2 _____/_____/_____
 Compressor 3 _____/_____/_____

Compressor 1 _____/_____/_____
 Fan 1 _____/_____/_____
 Compressor 2 _____/_____/_____
 Fan 2 _____/_____/_____
 Compressor 3 _____/_____/_____

Options Installed: _____

Comments: _____

1.- GENERAL CHARACTERISTICS

1.1.- TECHNICAL DATA

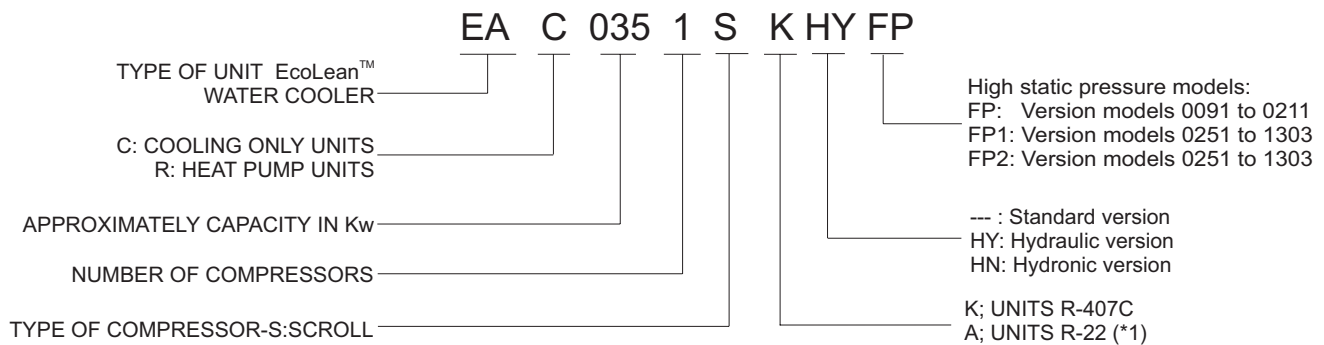

COOLING ONLY

EAC MODELS	0091 S	0111 S	0151 S	0191 S	0211 S	0251 S	0291 S	0351 S	0431 S	0472 S	0552 S	0672 S	0812 S	1003 S	1103 S	1203 S	1303 S		
Cooling capacity (*) kW.	8,8	11,1	13,3	17,3	19,1	23,0	27,0	32,0	38,5	44,0	51,4	62,5	75,5	90,0	101,0	114,5	127,0		
Compressor	Nr./Type: 1 / Scroll			2 / Scroll			3 / Scroll												
Hydraulic connections	1"G	1"G	1"G	1"G	1"G	1 1/2"G	1 1/2"G	1 1/2"G	1 1/2"G	2"G	2"G	2"G	2"G	2 1/2"G	2 1/2"G	2 1/2"G	2 1/2"G		
Min. water rate	m ³ /h.	1,21	1,53	1,83	2,38	2,63	3,16	3,72	4,40	5,30	6,05	7,07	8,60	10,39	12,38	13,90	15,76	17,48	
Net weight	kg.	147	155	168	181	245	272	281	309	345	540	551	596	670	803	948	1059	1104	
Net weight	FP-FP1	kg.	156	173	186	199	263	297	296	324	360	590	581	626	700	843	988	1099	1144
	FP2	kg.	---	---	---	---	---	317	316	344	380	630	621	666	740	843	988	1099	1144
Refrigerant R-407C	kg.	3,0	3,0	3,4	4,0	5,5	6,0	6,5	8,2	9,5	12,0	14,0	17,6	20,6	23,6	27,0	29,6	33,0	

HEAT PUMP

EAR MODELS	0091 S	0111 S	0151 S	0191 S	0211 S	0251 S	0291 S	0351 S	0431 S	0472 S	0552 S	0672 S	0812 S	1003 S	1103 S	1203 S	1303 S		
Cooling capacity (*) kW.	8,8	11,1	13,3	17,3	19,1	23,0	27,0	32,0	38,5	44,0	51,4	62,5	75,5	90,0	101,0	114,5	127,0		
Heating capacity (**) kW.	9,0	11,1	13,15	17,5	19,8	24,0	27,5	34,0	39,0	47,5	54,5	64,5	79,0	91,0	102,5	117,0	130,0		
Compressor	Nr./Type: 1 / Scroll			2 / Scroll			3 / Scroll												
Hydraulic connections	1"G	1"G	1"G	1"G	1"G	1 1/2"G	1 1/2"G	1 1/2"G	1 1/2"G	2"G	2"G	2"G	2"G	2 1/2"G	2 1/2"G	2 1/2"G	2 1/2"G		
Min. water rate	m ³ /h.	1,21	1,53	1,83	2,38	2,63	3,16	3,72	4,40	5,30	6,05	7,07	8,60	10,39	12,38	13,90	15,76	17,48	
Net weight	kg.	150	158	172	185	250	277	285	317	353	549	561	612	685	825	971	1084	1129	
Net weight	FP-FP1	kg.	159	176	190	204	268	302	301	332	368	599	592	642	716	865	1011	1124	1169
	FP2	kg.	---	---	---	---	---	322	321	352	388	639	632	682	756	865	1011	1124	1169
Refrigerant R-407C	kg.	3,1	3,1	3,9	5,0	6,5	6,2	7,0	9,0	10,5	12,4	14,0	18,0	21,0	25,2	28,2	30,5	34,0	

* Cooling capacity: Outside temperature: 35°C / Inlet/outlet water temperature: 12/7°C

** Heating capacity: Outside temperature: 7°C DB / 6°C WB / Inlet/water outlet temperature: 40/45°C

HYDRAULIC VERSION / HYDRONIC VERSION

Pump type:	Multicellular centrifugal pump with one speed																	
Expansion vessel	Capacity	5 L	5 L	5 L	5 L	5 L	12 L	12 L	12 L	12 L	18 L	18 L	18 L	18 L	35 L	35 L	35 L	35 L
SET PRESSURE																		
Security valves	bar	3	3	3	3	3	3	3	3	3	3	3	3	3	3	3	3	3
Expansion vessel	bar	4	4	4	4	4	4	4	4	4	4	4	4	4	4	4	4	4
Buffer tank (***)	Capacity	50 L	50 L	50 L	50 L	50 L	75 L	75 L	75 L	75 L	100 L	100 L	100 L	100 L	240 L	240 L	240 L	240 L

*** Only in units with Hydronic module

(*1) R22 is only for units used outside the EEC.

1.- GENERAL CHARACTERISTICS

1.1.- TECHNICAL DATA

STANDARD AXIAL FAN UNITS

MODELS	0091S	0111S	0151S	0191S	0211S	0251S	0291S	0351S	0431S	0472S	0552S	0672S	0812S		
Fan type	Axial - Direct coupling														
Fan number	1						2			1			2		
Air flow rate m ³ /h	3500	6500	6700	6500	6300	9500	11500	11000	10500	19000	23000	22000	21000		
Power Input kW	0,15	0,30	0,32	0,30	0,28	0,75	0,90	0,85	0,83	1,50	1,80	1,70	1,66		

MODELS	1003S				1103S				1203S				1303S					
Fan type	Axial - Direct coupling																	
Fan number	1+1																	
Air flow rate m ³ /h	High		32250				36250				36000				40000			
	Low		27250				29250				29000				31000			
Power Input kW	High		1,05 + 1,05				2 + 1,05				2 + 1,05				2 + 2			
	Low		0,77 + 0,77				1,25 + 0,77				1,25 + 0,77				1,25 + 1,25			
Fan speed rpm	High		700 + 700				900 + 700				900 + 700				900 + 900			
	Low		550 + 550				700 + 550				700 + 550				700 + 700			

HIGH STATIC PRESSURE UNITS

AVAILABLE STATIC PRESSURE UP TO 200 Pa - FP VERSION

MODELS	0091S-FP				0111S-FP				0151S-FP				0191S-FP				0211S-FP			
Fan type	Centrifugal - Direct coupling																			
Fan number	1								2											
Available static pressure Pa	Air flow rate m ³ /h		Power input kW		Air flow rate m ³ /h		Power input kW		Air flow rate m ³ /h		Power input kW		Air flow rate m ³ /h		Power input kW		Air flow rate m ³ /h		Power input kW	
50	3500		0,9		6500		1,9		6700		1,95		6500		1,9		6300		1,85	
100	2700		0,8		5700		1,75		5900		1,8		5700		1,75		5500		1,7	
150	2500		0,75		5200		1,6		5400		1,65		5200		1,6		5000		1,55	
200	2200		0,7		4700		1,45		4900		1,5		4700		1,45		4500		1,4	

AVAILABLE STATIC PRESSURE UP TO 120 Pa - FP1 VERSION

MODELS	0251S-FP1				0291S-FP1				0351S-FP1				0431S-FP1				0472S-FP1				0552S-FP1				0672S-FP1				0812S-FP1				1003S TO 1303S-FP1							
Fan type	Axial - Direct coupling																1450 rpm								1N~230V								900 rpm (Low speed) 3~400V							
Fan number	1																2																							
Available static pressure Pa	Air flow rate m ³ /h		Power input kW		Air flow rate m ³ /h		Power input kW		Air flow rate m ³ /h		Power input kW		Air flow rate m ³ /h		Power input kW		Air flow rate m ³ /h		Power input kW		Air flow rate m ³ /h		Power input kW		Air flow rate m ³ /h		Power input kW		Air flow rate m ³ /h		Power input kW									
50	11500		1,7		11500		1,7		11000		1,65		10500		1,65		23000		3,4		23000		3,4		22000		3,3		21000		3,3		36000		5					
75	9600		1,65		9600		1,65		9200		1,6		8800		1,6		19200		3,3		19200		3,3		18400		3,2		17600		3,2		34000		5,1					
100	8500		1,6		8500		1,6		8100		1,55		7700		1,55		17000		3,2		17000		3,2		16200		3,1		15400		3,1		32000		5,2					
125	7200		1,55		7200		1,55		6900		1,5		6600		1,5		14400		3,1		14400		3,1		13800		3		13200		3		28000		5,3					

AVAILABLE STATIC PRESSURE UP TO 250 OR 350 Pa - FP2 VERSION

MODELS	0251S-FP2				0291S-FP2				0351S-FP2				0431S-FP2				0472S-FP2				0552S-FP2				0672S-FP2				0812S-FP2				1003S TO 1303S-FP2							
Fan type	Axial "short case" - Direct coupling																1450 rpm								3~230V/3~400V								1450 rpm (High speed) 3~400V							
Fan number	1																2																							
Available static pressure Pa	Air flow rate m ³ /h		Power input kW		Air flow rate m ³ /h		Power input kW		Air flow rate m ³ /h		Power input kW		Air flow rate m ³ /h		Power input kW		Air flow rate m ³ /h		Power input kW		Air flow rate m ³ /h		Power input kW		Air flow rate m ³ /h		Power input kW		Air flow rate m ³ /h		Power input kW									
150	12400		2,45		12400		2,45		11900		2,4		11500		2,35		24800		4,9		24800		4,9		23800		4,8		23000		4,7		44000		9,2					
200	10800		2,3		10800		2,3		10400		2,3		10000		2,25		21600		4,6		21600		4,6		20800		4,6		20000		4,5		40000		9,3					
250	9200		2,3		9200		2,3		8800		2,3		8500		2,3		18400		4,6		18400		4,6		17600		4,6		17000		4,6		36000		9,4					
300	7800		2,4		7800		2,4		7500		2,4		7250		2,45		15600		4,8		15600		4,8		15000		4,8		14500		4,9		N/A		N/A					
350	6800		2,45		6800		2,45		6500		2,45		6250		2,5		13600		4,9		13600		4,9		13000		4,9		12500		5		N/A		N/A					

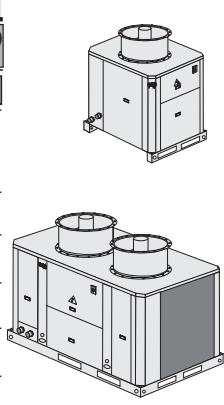
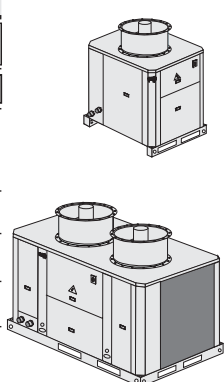
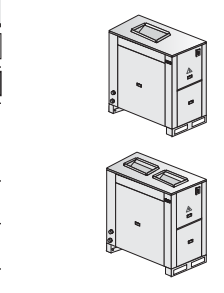
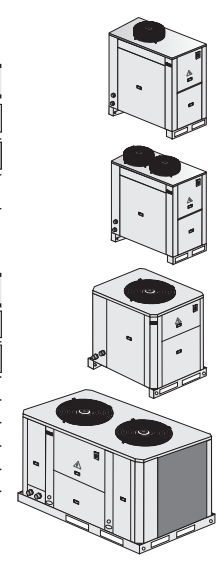

1.- GENERAL CHARACTERISTICS

1.2.- STANDARD UNIT ELECTRICAL DATA

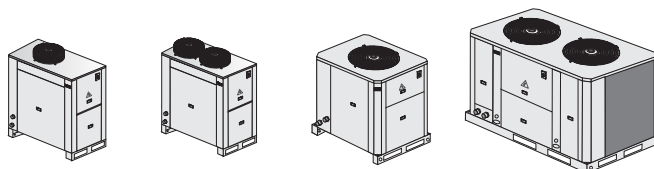

EAC / EAR MODELS		0091S	0111S	0151S	0191S	0211S	0251S	0291S	0351S	0431S		
Voltage	V/f (50 Hz)	1N~230V		3~230V - 3N~400V								
		Compressor	kW.	4,05	4,70	5,78	7,60	8,62	11,15	12,90	15,55	19,77
Maximum consumption	Fan motor	kW.	0,15	0,30	0,32	0,30	0,28	0,75	0,90	0,85	0,83	
	Total power	kW.	4,20	5,00	6,10	7,90	8,90	11,90	13,80	16,40	20,60	
	Maximum current	Compressor	A	1N~230V	23,10	---	---	---	---	---	---	---
A			3~230V	12,12	17,32	21,48	27,71	26,15	31,17	35,85	44,34	51,61
A			3~400V	7,00	10,00	12,40	16,00	15,10	18,00	20,70	25,60	29,80
Maximum current	Fan motor	A	1N~230V	0,80	1,60	1,60	1,60	1,60	3,00	3,50	3,50	3,50
		A	3~230V	23,90	---	---	---	---	---	---	---	---
		A	3N~400V	12,92	18,92	23,08	29,31	27,75	34,17	39,35	47,84	55,11
LRC	Total current	A	1N~230V	7,80	11,60	14,00	17,60	16,70	21,00	24,20	29,10	33,30
		A	3~230V	95,80	---	---	---	---	---	---	---	---
		A	3~400V	91,80	99,60	134,60	179,60	167,60	213,00	227,50	282,50	333,50
LRC	Total current	A	3~400V	44,30	51,60	63,60	97,40	95,60	119,00	130,50	161,50	192,50

HYDRAULIC VERSION / HYDRONIC VERSION

Water pump	V/f (50 Hz)	1N~230V				3~230V - 3~400V					
		Maximum absorbed power	kW.	0,49	0,49	0,49	0,72	0,72	0,72	0,72	1,10
Maximum current	A	1N~230V	2,30	2,30	2,30	---	---	---	---	---	---
		3~230V	---	---	---	2,40	2,40	2,40	2,40	3,00	3,00
		3~400V	---	---	---	1,40	1,40	1,40	1,40	1,70	1,70

EAC / EAR MODELS		0472S	0552S	0672S	0812S	1003S	1103S	1203S	1303S		
Voltage	V/f (50 Hz)	3~230V - 3N~400V				3N~400V					
		Compressor	kW.	22,10	25,50	30,90	38,14	45,6	51	56,2	62
Maximum consumption	Fan motor	kW.	1,50	1,80	1,70	1,66	2,1	3,1	3,1	4	
	Total power	kW.	23,60	27,30	32,60	39,80	47,7	54,1	59,3	66	
	Maximum current	Compressor	A	3~230V	62,35	71,70	88,68	103,22	---	---	---
A			3~400V	36,00	41,40	51,20	59,60	71,2	81	91,2	99,2
A			3~230V	6,00	7,00	7,00	7,00	4,8	6,4	6,4	8
Maximum current	Total current	A	3~230V	68,35	78,70	95,68	110,22	---	---	---	---
		A	3N~400V	42,00	48,40	58,20	66,60	76	87,4	97,6	107,2
LRC	Total current	A	3~230V	243,70	262,70	324,10	382,00	---	---	---	---
		A	3N~400V	138,00	152,30	187,00	222,00	235,2	246,6	282,6	331,2

HYDRAULIC VERSION / HYDRONIC VERSION

Water pump	V/f (50 Hz)	3~230V - 3~400V				3~400V				
		Maximum absorbed power	kW.	1,17	1,17	1,55	1,55	2,20	2,30	2,50
Maximum current	A	3~230V	3,00	3,00	4,80	4,80	---	---	---	---
		3~400V	1,70	1,70	2,80	2,80	3,70	3,90	4,20	4,50

1.- GENERAL CHARACTERISTICS

1.2.- HIGH STATIC PRESSURE UNIT ELECTRICAL DATA

FP VERSION

EAC / EAR MODELS		0091S	0111S	0151S	0191S	0211S		
Voltage	V/f (50 Hz)	1N~230V						
		3~230V - 3N~400V						
Maximum consumption	Compressor	kW.	4,05	4,70	5,78	7,60	8,62	
	Fan motor	kW.	0,90	1,90	1,95	1,90	1,85	
	Total power	kW.	4,95	6,60	7,73	9,50	10,47	
Maximum current	Compressor	A	1N~230V	23,10	---	---	---	---
		A	3~230V	12,12	17,32	21,48	27,71	26,15
			3~400V	7,00	10,00	12,40	16,00	15,10
	Fan motor	A	4,00	8,00	8,00	8,00	8,00	
	Total current	A	1N~230V	27,10	---	---	---	---
LRC	Total current	A	3~230V	99,00	---	---	---	---
		A	3~230V	95,00	106,00	141,00	186,00	174,00
		A	3N~400V	47,50	58,00	70,00	103,80	102,00

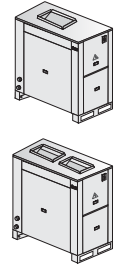

HYDRAULIC VERSION / HYDRONIC VERSION							
Water pump	V/f (50 Hz)	1N~230V			3~230V - 3~400V		
Maximum absorbed power	kW.	0,49	0,49	0,49	0,72	0,72	
Maximum current	A	1N~230V	2,30	2,30	2,30	---	---
		3~230V	---	---	---	2,40	2,40
		3~400V	---	---	---	1,40	1,40

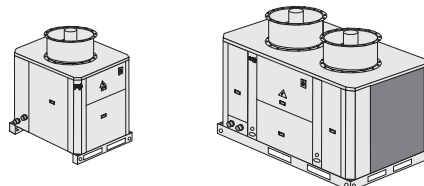

FP1 VERSION

EAC / EAR MODELS		0251S	0291S	0351S	0431S	0472S	0552S	0672S	0812S	1003S	1103S	1203S	1303S		
Voltage	V/f (50 Hz)	3~230V - 3N~400V								3N~400V					
Maximum consumption	Compressor	kW.	11,15	12,90	15,55	19,77	22,10	25,50	30,90	38,14	45,60	51,00	56,20	62,00	
	Fan motor	kW.	1,70	1,70	1,65	1,65	3,40	3,40	3,30	3,30	5,00	5,00	5,00	5,00	
	Total power	kW.	12,85	14,60	17,20	21,42	25,50	28,90	34,20	41,44	50,60	56,00	61,20	67,00	
Maximum current	Compressor	A	3~230V	31,17	35,85	44,34	51,61	62,35	71,70	88,68	103,22	---	---	---	
		A	3~400V	18,00	20,70	25,60	29,80	36,00	41,40	51,20	59,60	71,20	81,00	91,20	99,20
	Fan motor	A	8,00	8,00	8,00	8,00	16,00	16,00	16,00	16,00	9,60	9,60	9,60	9,60	
	Total current	A	3~230V	39,17	43,85	52,34	59,61	78,35	87,70	104,68	119,22	---	---	---	
LRC	Total current	A	3N~400V	26,00	28,70	33,60	37,80	52,00	57,40	67,20	75,60	80,80	90,60	100,8	108,8
		A	3~230V	218,00	232,00	287,00	338,00	253,68	271,66	333,06	390,98	---	---	---	---
		A	3N~400V	124,00	135,00	166,00	197,00	148,00	161,30	196,00	231,00	240,00	249,80	285,80	332,80

HYDRAULIC VERSION / HYDRONIC VERSION														
Water pump	V/f (50 Hz)	3~230V - 3~400V								3~400V				
Maximum absorbed power	kW.	0,72	0,72	1,10	1,10	1,17	1,17	1,55	1,55	2,20	2,30	2,50	2,70	
Maximum current	A	3~230V	2,40	2,40	3,00	3,00	3,00	3,00	4,80	4,80	---	---	---	---
		3~400V	1,40	1,40	1,70	1,70	1,70	1,70	2,80	2,80	3,70	3,90	4,20	4,50

1.- GENERAL CHARACTERISTICS

1.2.- HIGH STATIC PRESSURE UNIT ELECTRICAL DATA

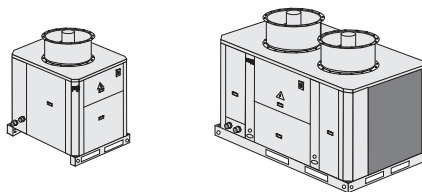

FP2 VERSION

EAC / EAR MODELS		0251S	0291S	0351S	0431S	0472S	0552S	0672S	0812S	1003S	1103S	1203S	1303S
Voltage	V/f (50 Hz)	3~230V - 3N~400V								3N~400V			
Maximum consumption	Compressor kW.	11,15	12,90	15,55	19,77	22,10	25,50	30,90	38,14	45,60	51,00	56,20	62,00
	Fan motor kW.	2,45	2,45	2,40	2,35	4,90	4,90	4,80	4,70	9,20	9,20	9,20	9,20
	Total power kW.	13,60	15,35	17,95	22,12	27,00	30,40	35,70	42,84	54,80	60,20	65,40	71,20
Maximum current	Compressor A	3~230V 31,17 3~400V 18,00	35,85 20,70	44,34 25,60	51,61 29,80	62,35 36,00	71,70 41,40	88,68 51,20	103,22 59,60	---	---	---	---
	Fan motor A	3~230V 8,00 3~400V 4,50	8,00 4,50	8,00 4,50	8,00 4,50	16,00 9,00	16,00 9,00	16,00 9,00	16,00 9,00	---	---	---	---
	Total current A	3~230V 39,17 3N~400V 22,50	43,85 25,20	52,34 30,10	59,61 34,30	78,35 45,00	87,70 50,40	104,68 60,20	119,22 68,60	---	---	---	---
LRC	Total current A	3~230V 218,00 3N~400V 120,50	232,00 131,50	287,00 162,50	338,00 193,50	253,68 141,00	271,66 154,30	333,06 189,00	390,98 224,00	---	---	---	---

HYDRAULIC VERSION / HYDRONIC VERSION		0251S	0291S	0351S	0431S	0472S	0552S	0672S	0812S	1003S	1103S	1203S	1303S
Water pump	V/f (50 Hz)	3~230V - 3~400V								3~400V			
Maximum absorbed power	kW.	0,72	0,72	1,10	1,10	1,17	1,17	1,55	1,55	2,20	2,30	2,50	2,70
Maximum current	A	3~230V 2,40 3~400V 1,40	2,40 1,40	3,00 1,70	3,00 1,70	3,00 1,70	3,00 1,70	4,80 2,80	4,80 2,80	---	---	---	---

1.- GENERAL CHARACTERISTICS

1.3.- COMPONENT

The EcoLean™ system comprises a water cooler or air/water pump combined with a series of hydraulic accessories obtaining the Hydraulic or Hydronic version.

COMPONENTS:

HYDRONIC VERSION:

1,2,3,4,5,6,7,8,9,10,11

HYDRAULIC VERSION:

1,4,5,6,7,8,9,10,11

1.- Detachable water filter

2.- Water tank

3.- Water tank heater

(in option)

4.- Safety valve

5.- Manometer

6.- Expansion vessel

7.- Water pump

8.- Air purge valve

9.- Plate exchanger

10.- Flow switch

11.- Drain valve

12.- Water isolation valves

(in option)

HYDRONIC VERSION

Models 0091 to 0812

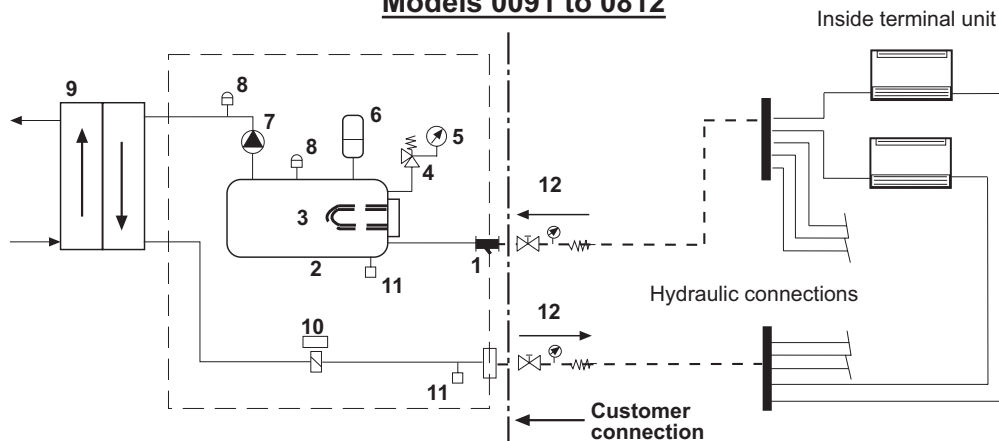

Models 1003 to 1303

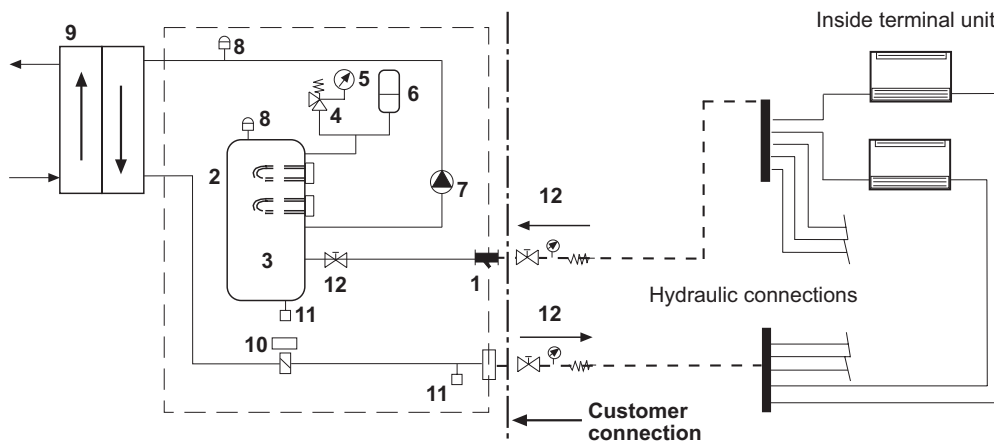

HYDRAULIC VERSION

Models 0091 to 1303

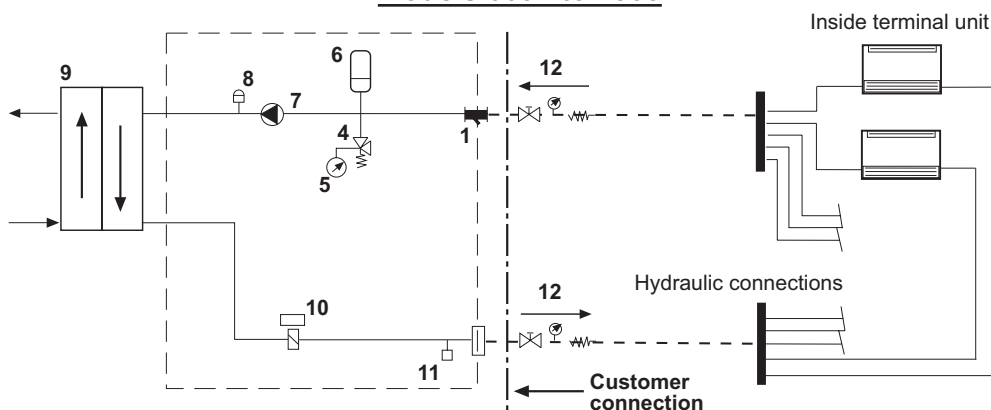

1.- GENERAL CHARACTERISTICS

1.4.- OPERATION LIMITS

STANDARD AXIAL FAN UNITS WITHOUT AIR DUCTS

COOLING MODE

MODELS	EAC / EAR	0091 TO 0431S	0472 TO 0812S	1003 TO 1303S
Outlet chilled water temperature		Minimum : +5°C Maximum : +12°C	Minimum : +5°C Maximum : +12°C	Minimum : +5°C Maximum : +12°C
Inlet chilled water temperature		Minimum : +10 °C Maximum : +17°C	Minimum : +9 °C Maximum : +17°C	Minimum : +8°C Maximum : +17°C
Air inlet temperature		Minimum : 0°C (1) Maximum : +46°C	Minimum : 0°C (1) Maximum : +46°C	Minimum : 0°C (1) Maximum : +46°C

NOTE: With outdoor temperatures below +5°C, add glycol

(1) With the option cooling low ambient kit (-15°C), it is possible the unit operation down to -15°C in EAC units.

HEATING MODE

MODELS	EAR	0091 TO 0812S	1003 TO 1303S
Hot water outlet temperature (operation)		Minimum : +20°C Maximum : +50°C	Minimum : +20°C Maximum : +50°C
Hot water inlet temperature (start)		Minimum : +10 °C Maximum : +43°C	Minimum : +10°C Maximum : +43°C
Difference hot water inlet/outlet		Minimum : +3°C Maximum : +8°C	Minimum : +3°C Maximum : +8°C
Air inlet temperature		Minimum : -10°C (2) Maximum : +23°C	Minimum : -10°C (2) Maximum : +23°C

OUTSIDE THESE VALUES, PLEASE CONSULT US

(2) With the option heating low ambient kit (-15°C), it is possible the unit operation down to -15°C

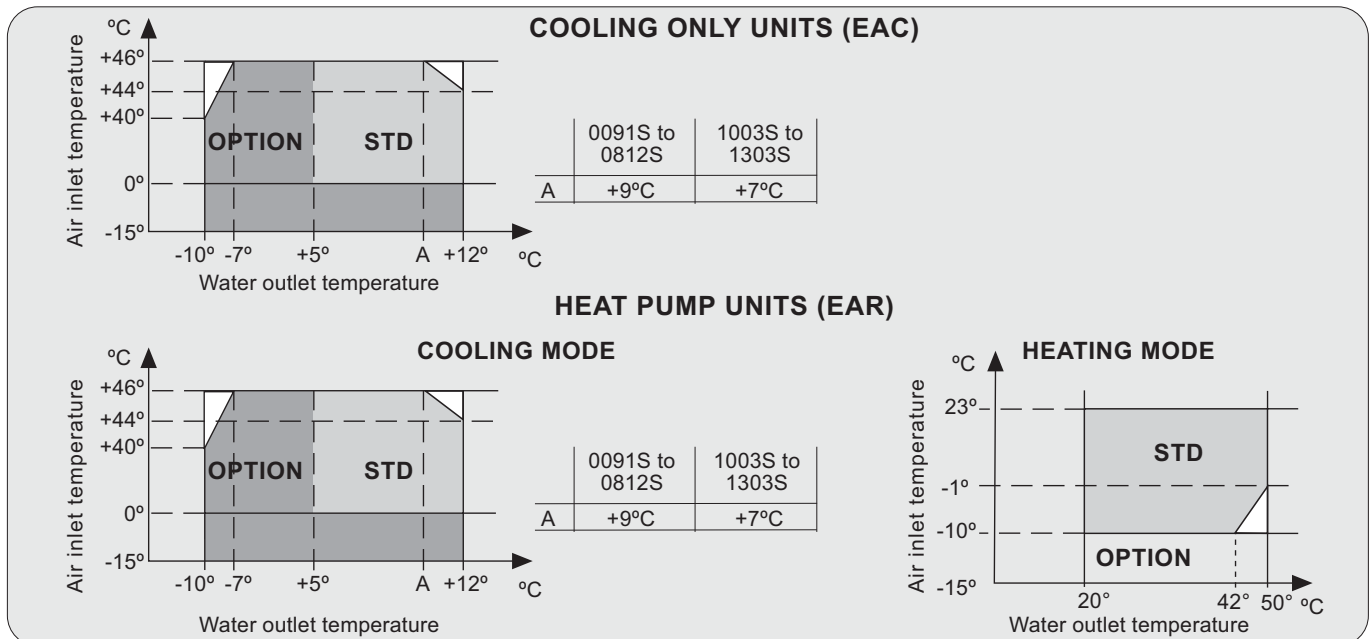

NOTE: With outdoor temperatures below +5°C, add glycol.

STANDARD AXIAL FAN UNITS WITH AIR DUCTS

COOLING MODE

AVAILABLE PRESSURE UP TO 50 Pa	0091 to 0211S		0251 to 1303S	
	Available static pressure Pa	30	50	30
Maximum ambient temperature °C	43	40	42	38

HEATING MODE

AVAILABLE PRESSURE UP TO 50 Pa	0091 to 0211S		0251 to 1303S	
	Available static pressure Pa	30	50	30
Minimum ambient temperature °C (1)	-8	-6	-8	-6

(1) With the option heating low ambient kit (-15°C), it is possible the unit operation down to -15°C

1.- GENERAL CHARACTERISTICS

1.4.- OPERATION LIMITS

HIGH STATIC PRESSURE UNITS

COOLING MODE

AVAILABLE PRESSURE UP TO 200 Pa FP VERSION	0091 to 0211S-FP MODEL UNITS			
Available static pressure Pa	50	100	150	200
Maximum ambient temperature °C	46	45	41	38
Minimum ambient temperature °C	0°C (1)			

AVAILABLE PRESSURE UP TO 120 Pa FP1 VERSION	0251 to 1003S-FP1 MODEL UNITS				1103 to 1303S-FP1 MODEL UNITS			
Available static pressure Pa	50	75	100	125	50	75	100	125
Maximum ambient temperature °C	46	43	39	35	44	41	37	35
Minimum ambient temperature °C	0°C (1)				0°C (1)			

AVAILABLE PRESSURE UP TO 250 OR 350 Pa FP2 VERSION	0251 to 0812S-FP2 MODEL UNITS					1003 to 1303S-FP2 MODEL UNITS				
Available static pressure Pa	150	200	250	300	350	150	200	250	300	350
Maximum ambient temperature °C	47	44	41	38	35	47	44	41	N/A	N/A
Minimum ambient temperature °C	0°C					0°C (1)				

(1) With the option cooling low ambient kit (-15°C), it is possible the unit operation down to -15°C.

HEATING MODE

AVAILABLE PRESSURE UP TO 200 Pa FP VERSION	0091 to 0211S-FP MODEL UNITS			
Available static pressure Pa	50	100	150	200
Minimum ambient temperature °C (2)	-10	-10	-8	-6

AVAILABLE PRESSURE UP TO 120 Pa FP1 VERSION	0251 to 1303S-FP1 MODEL UNITS			
Available static pressure Pa	50	75	100	125
Minimum ambient temperature °C (2)	-10	-8	-6	-5

AVAILABLE PRESSURE UP TO 250 OR 350 Pa FP2 VERSION	0251 to 0812S-FP2 MODEL UNITS					1003 to 1303S-FP2 MODEL UNITS				
Available static pressure Pa	150	200	250	300	350	150	200	250	300	350
Minimum ambient temperature °C (2)	-10	-10	-8	-6	-5	-10	-10	-8	N/A	N/A

(2) With the option heating low ambient kit (-15°C), it is possible the unit operation down to -15°C.

UNITS WITH LOW WATER TEMPERATURE KIT (OPTION)

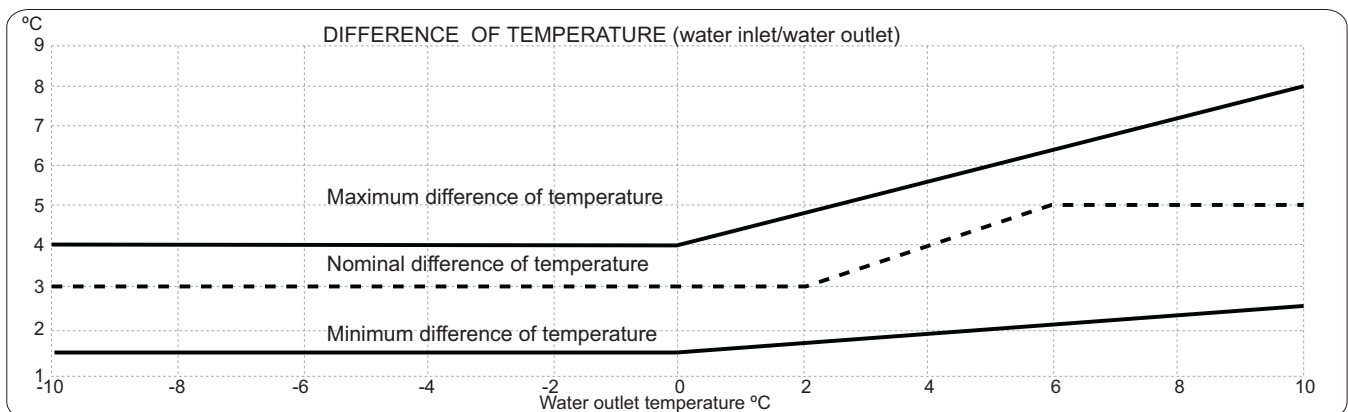

1.- GENERAL CHARACTERISTICS

1.5.- PRESSURE DROP IN THE WATER SYSTEM



INSTALLATION ADVISE

The units **MUST** be fitted with a water filter at the inlet to the unit (trapping any particles with a diameter greater than 1 mm.)

MODELS EAC / EAR 0091 TO 0431

PRESSURE DROP WITHOUT FILTER

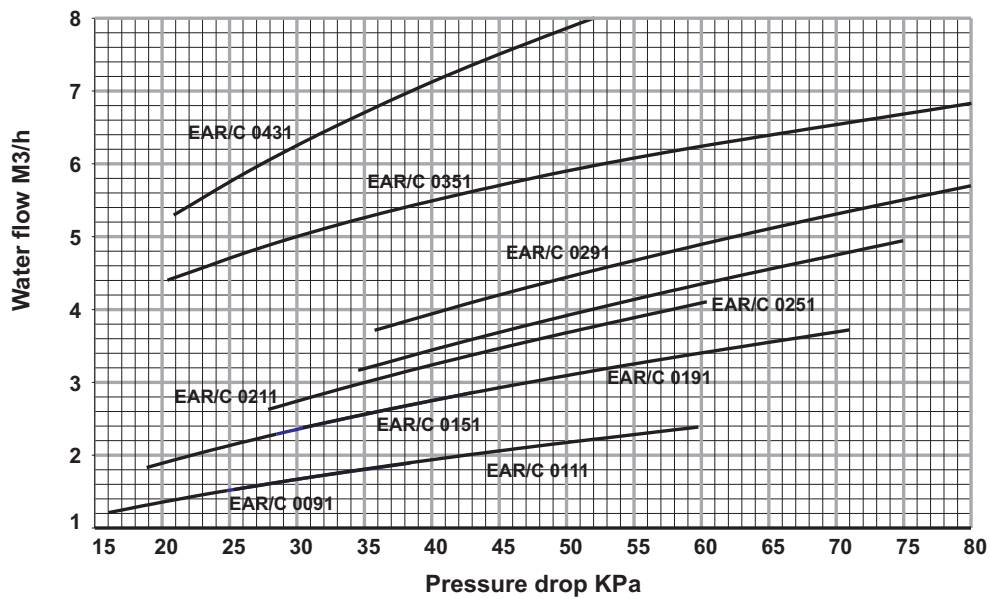

PRESSURE DROP + WATER FILTER (*)

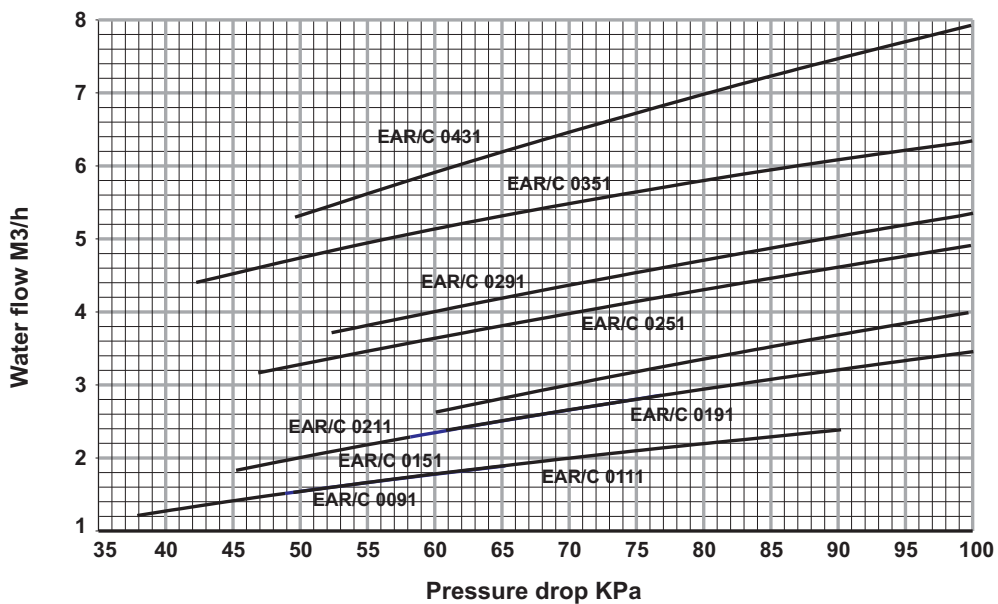

(*) Option in standard version, included in Hydronic and Hydraulic version.

1.- GENERAL CHARACTERISTICS

1.5.- PRESSURE DROP IN THE WATER SYSTEM



INSTALLATION ADVISE

The units **MUST** be fitted with a water filter at the inlet to the unit (trapping any particles with a diameter greater than 1 mm.)

MODELS 0472 TO 1303

COOLING ONLY (EAC)

PRESSURE DROP WITHOUT FILTER

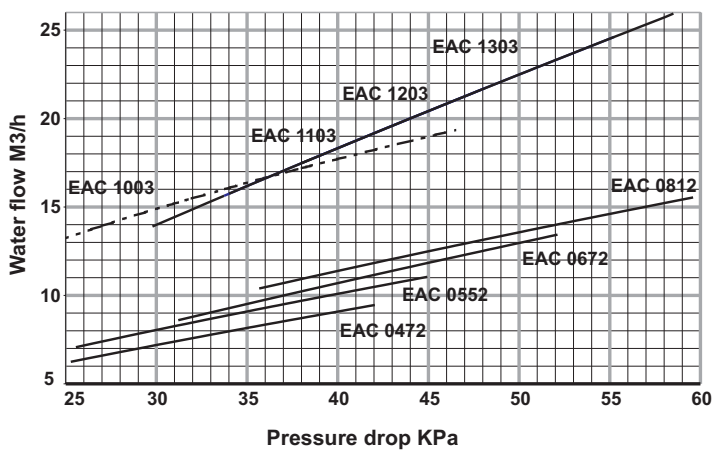

PRESSURE DROP + WATER FILTER (*)

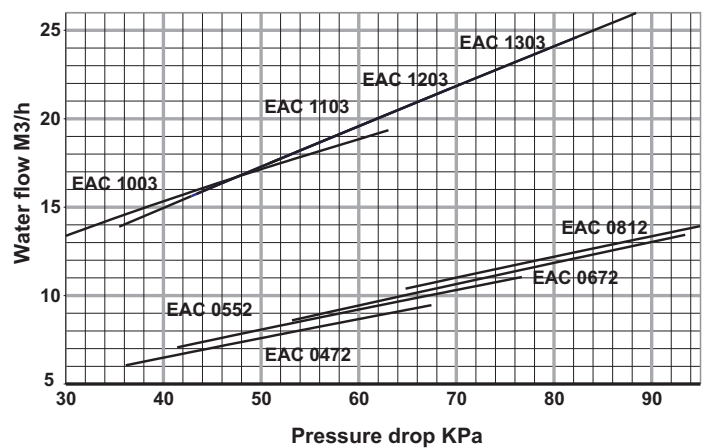

HEAT PUMPS (EAR)

PRESSURE DROP WITHOUT FILTER

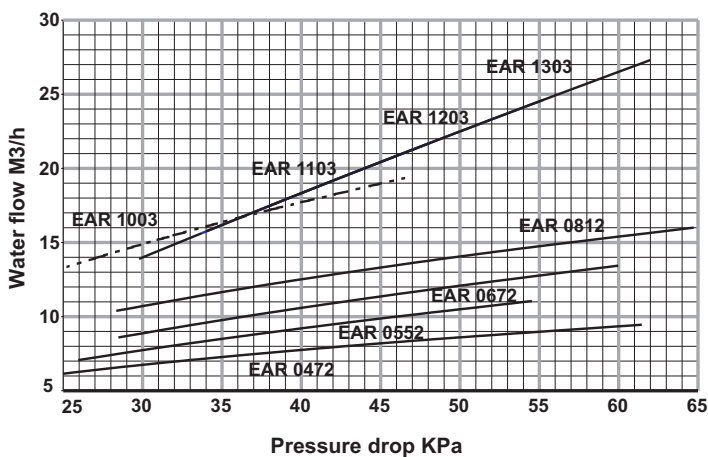

PRESSURE DROP + WATER FILTER (*)

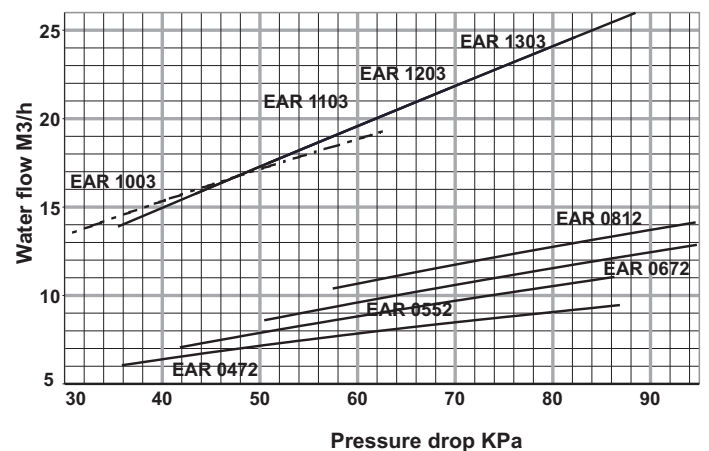

(*) Option in standard version, included in Hydronic and Hydraulic version.

1.- GENERAL CHARACTERISTICS

1.6.- HYDRAULIC SYSTEM DATA

WATER FLOW AND AVAILABLE STATIC PRESSURE (Factory supplied; standard water pump and filter).

	MODEL	EAC / EAR 0091S					EAC / EAR 0111S					EAC / EAR 0151S				
Water flow	l/s	0,34	0,38	0,42	0,47	0,53	0,42	0,48	0,53	0,59	0,66	0,51	0,57	0,64	0,71	0,79
	m ³ /h	1,21	1,36	1,51	1,68	1,89	1,53	1,72	1,91	2,12	2,39	1,83	2,06	2,29	2,54	2,86
Available static pressure	kPa	216	207	196	183	163	196	178	161	144	126	186	170	152	132	104
	MODEL	EAC / EAR 0191S					EAC / EAR 0211S					EAC / EAR 0251S				
Water flow	l/s	0,66	0,74	0,83	0,92	1,03	0,73	0,82	0,91	1,01	1,14	0,88	0,99	1,10	1,22	1,37
	m ³ /h	2,38	2,68	2,98	3,31	3,72	2,63	2,96	3,29	3,65	4,11	3,16	3,56	3,96	4,40	4,95
Available static pressure	kPa	170	154	140	124	107	167	144	126	111	100	175	152	131	110	87
	MODEL	EAC / EAR 0291S					EAC / EAR 0351S					EAC / EAR 0431S				
Water flow	l/s	1,03	1,16	1,29	1,43	1,61	1,22	1,38	1,53	1,70	1,91	1,47	1,66	1,84	2,04	
	m ³ /h	3,72	4,18	4,64	5,16	5,81	4,40	4,95	5,50	6,12	6,88	5,30	5,96	6,62	7,36	
Available static pressure	kPa	153	129	106	83	55	210	176	140	98	43	161	132	96	47	
	MODEL	EAR 0472S					EAR 0552S					EAR 0672S				
Water flow	l/s	1,68	1,89	2,10	2,34	2,63	1,96	2,21	2,46	2,73	3,07	2,39	2,69	2,99	3,32	3,73
	m ³ /h	6,05	6,81	7,57	8,41	9,46	7,07	7,96	8,84	9,82	11,05	8,60	9,68	10,75	11,94	13,44
Available static pressure	kPa	156	139	122	104	82	140	126	111	93	69	226	195	164	131	90
	MODEL	EAR 0812S					EAC 0472S					EAC 0552S				
Water flow	l/s	2,89	3,25	3,61	4,01	1,68	1,89	2,10	2,34	2,63	1,96	2,21	2,46	2,73	3,07	
	m ³ /h	10,39	11,69	12,99	14,43	6,05	6,81	7,57	8,41	9,46	7,07	7,96	8,84	9,82	11,05	
Available static pressure	kPa	188	153	111	56	156	141	128	115	101	140	128	115	99	78	
	MODEL	EAC 0672S					EAC 0812S					EAC / EAR 1003S				
Water flow	l/s	2,39	2,69	2,99	3,32	3,73	2,89	3,25	3,61	4,01	3,44	3,87	4,30	4,78	5,38	
	m ³ /h	8,60	9,68	10,75	11,94	13,44	10,39	11,69	12,99	14,43	12,38	13,93	15,48	17,20	19,35	
Available static pressure	kPa	223	194	165	134	97	180	147	107	54	215	206	196	183	164	
	MODEL	EAC / EAR 1103S					EAC / EAR 1203S					EAC / EAR 1303S				
Water flow	l/s	3,86	4,34	4,83	5,36	6,03	4,38	4,92	5,47	6,08	6,84	4,85	5,46	6,07	6,74	7,58
	m ³ /h	13,90	15,63	17,37	19,30	21,72	15,76	17,72	19,69	21,88	24,62	17,48	19,66	21,84	24,27	27,31
Available static pressure	kPa	206	195	181	164	139	194	178	160	138	105	180	161	138	109	75

NOTE: The flow data indicated in table are between a minimum and a maximum water flow

With the option twin pump kit, the available static pressure will decrease 5% from the data shown above

Unit conversion:

Pressure 1KPa = 1/9,8 m.c.a. = 0,01 bar

1 bar = 10 m.c.a. = 100 kPa

MINIMUM WATER FLOW

The installation must never operate with less than the minimum water flow (see table above), this will cause:

- i. - Freezing the water heat exchanger.
- ii. - Contamination of the heat exchanger.

MAXIMUM WATER FLOW

See maximum water flow, (see table above). Always assure the minimum ΔT to the exchanger of 3°C.

MAXIMUM WATER VOLUME IN THE INSTALLATION

The units with Hydronic or Hydraulic module include a expansion vessel.

The table below details the maximum water volume in the system.

Models	0091/0211	0251/0431	0472/0812	1003/1303
Solution	Water volume in liters			
Water	225	550	850	1650
Water + 10% gyt	175	400	650	1260
Water + 20% gyt	150	350	575	1115
Water + 30% gyt	125	300	450	875
Water + 35% gyt	110	225	325	650

If the water volume in the system is greater than that detailed in the table it will be necessary to add additional expansion vessel(s).

The system design must allow for water expansion and contraction.

1.- GENERAL CHARACTERISTICS

1.7.- SAFETY DEVICES



It is strictly forbidden to change or remove any safety device.

When a safety device is activated, qualified personnel must investigate the unit and rectify the problem.

Note: Before resetting a safety device, the cause of the problem must be found and rectified before the unit can be restarted.

The units contain the following safety devices:

- 1.- Electrical safety devices.
 - 2.- Cooling system safety devices.
 - 3.- Water system safety devices.
- They protect the unit's operation under both normal and abnormal conditions.

ELECTRICAL SAFETY DEVICES

- The control circuit is protected against overloads and short circuits by a circuit breaker.
- The power circuit is protected against short circuit by fuses.
- The compressor and fan motors are also protected against overloads by an internal safety device.

Units

ADJUSTMENTS		0091S	0111S	0151S	0191S	0211S	0251S	0291S	0351S	0431S	0472S	0552S	0672S	0812S	1003S	1103S	1203S	1303S	
Compressor fuses	A (1N~230V)	1X32	--	--	--	--	--	--	--	--	--	--	--	--	--	--	--	--	
	A (3~230V)	3X20	3X25	3X25	3X32	3X40	3X40	3X50	3X62	3X80	6x40	6x50	6x63	6x80	--	--	--	--	
	A (3~400V)	3X10	3x16	3x16	3x20	3x20	3x25	3x25	3x32	3x40	6x25	6x25	6x32	6x40	6x25	6x32	6x32	6x32	
Water pump fuses	A (1N~230V)	1x6	1x6	1x6	--	--	--	--	--	--	--	--	--	--	--	--	--	--	
	A (3~230V)	--	--	--	3x6	3x6	3x6	3x6	3x6	3x6	3x6	3x6	3x6	3x6	--	--	--	--	
	A (3~400V)	--	--	--	3x6	3x6	3x6	3x6	3x6	3x6	3x6	3x6	3x6	3x6	3x10	3x10	3x10	3x10	
Fan fuses	Standard	A (1N~230V)	--	--	--	--	--	--	--	--	1x16	1x16	1x16	1x16	--	--	--	--	
		A (3~400V)	--	--	--	--	--	--	--	--	--	--	--	--	6x10	6x10	6x10	6x10	
	FP	--	--	--	--	--	--	--	--	--	--	--	--	--	--	--	--	--	
	FP1	A (1N~230V)	--	--	--	--	--	1x10	1x10	1x10	1x10	1x20	1x20	1x20	1x20	--	--	--	--
		A (3~400V)	--	--	--	--	--	--	--	--	--	--	--	--	--	6x10	6x10	6x10	6x10
	FP2	A (3~230V)	--	--	--	--	--	3X10	3X10	3X10	3X10	6x10	6x10	6x10	6x10	--	--	--	--
A (3~400V)		--	--	--	--	--	3X16	3X16	3X16	3X16	6x16	6x16	6x16	6x16	6x10	6x10	6x10	6x10	

SYSTEM SAFETY DEVICES

Pressure switches

HIGH PRESSURE (HP): The system is protected against high system pressure by a high pressure switch HP trip is reset manually by resetting the controller.

LOW PRESSURE (LP): The system is protected against low system pressures by a low pressure switch. The controller will stop the unit if the system low pressure set point is reached 3 times in one hour. The LP trip is reset manually by resetting the controller.

For heat pump units there are two low pressure switches one for cooling operation, the other for heating operation.

Operation for LP is the same but set point varies for the different operating modes.

ON START UP LP IS BYE PASSED FOR 2MIN.

ADJUSTMENTS		SET	RESET	SET	RESET
High pressure switch (bar)		28,7	24	28,7	24
Low pressure switch heat cycle (bar)		0,5	1,5	0,5	1,5
Low pressure switch timer (minutes)		2'			
Low pressure switch cool cycle (bar)		Ambient temp. standard		Option low ambient to -15°C	
Standard water temperature		1,8	2,7	0,5	1,5
Option low water temperature	0°C OPTION 1	2	2,5	1,5	2
	-5°C OPTION 2	1,5	2	1	1,5
	-10°C OPTION 3	0,8	1,3	0,5	1

1.- GENERAL CHARACTERISTICS

1.7.- SAFETY DEVICES

WATER SYSTEM SAFETY DEVICES (included in units with Hydraulic or Hydronic module)

These units contain various safety devices, to protect against system damage.

1.- Flow switch (option for standard unit)

Stop the unit if water flow is under limits. Operating with water flow under limits is completely forbidden.

2.- Water filter (supply loose for standard unit)

The water filter protects the unit against particles getting inside the circuit. The units must be fitted with a water filter.



IT IS NECESSARY TO FIT A WATER FILTER IN THE WATER INLET OF THE UNIT

3.- Anti-freeze protection

This protection is activated by the control of the unit.

It comes ON when the water outlet temperature probe (ST2), located inside the water interchanger, measures a certain temperature and RESETS when the water outlet temperature reaches set temperature as the following table shows:

	STANDARD UNIT (°C)	UNIT WITH LOW WATER TEMPERATURE KIT (°C)		
		0°C	-5°C	-10°C
Protection ON	+5°C	-2°C	-7°C	-12°C
Protection RESET	+6°C	0°C	-5°C	-10°C

If the unit is on STAND-BY as the operating mode and the protection is activated: the water pump comes on, along with electrical heater of evaporator and electrical heater of water tank (if included).



DO NOT TURN OFF THE POWER TO THE UNIT. WHEN THE POWER IS OFF THE ANTI FREEZE PROTECTION WILL NOT OPERATE.

- If the unit is operating in cooling mode: The power feeds the electrical heater of water tank, the electrical heater of the water heat exchanger, and activates the hot gas injection valve (if the unit is fitted with these options).
- If the unit is operating in heating mode: The power feeds the electrical heater of water tank and the electrical heater of the water heat exchanger (if the unit is fitted with these options).

4.- Low water temperature alarm

This alarm activates when the water outlet temperature probe (ST2) measures a certain temperature, the unit goes off, at table conditions below:

	STANDARD UNIT (°C)	UNIT WITH LOW WATER TEMPERATURE KIT (°C)		
		0°C	-5°C	-10°C
Alarm ON	+3°C	-3°C	-8°C	-13°C

OTHER PROTECTION

Compressor crank case heater

Located around compressors, this protection is activated when the compressor stops, to maintain the compressor oil temperature preventing the refrigerant diluting into the compressor oil.



DO NOT TURN OFF THE POWER TO THE UNIT. WHEN THE POWER IS OFF THE CRANK CASE HEATER PROTECTION WILL NOT OPERATE.

1.- GENERAL CHARACTERISTICS

1.8.- PIPING DRAWINGS

COOLING ONLY UNITS EAC 0091S TO 0431S

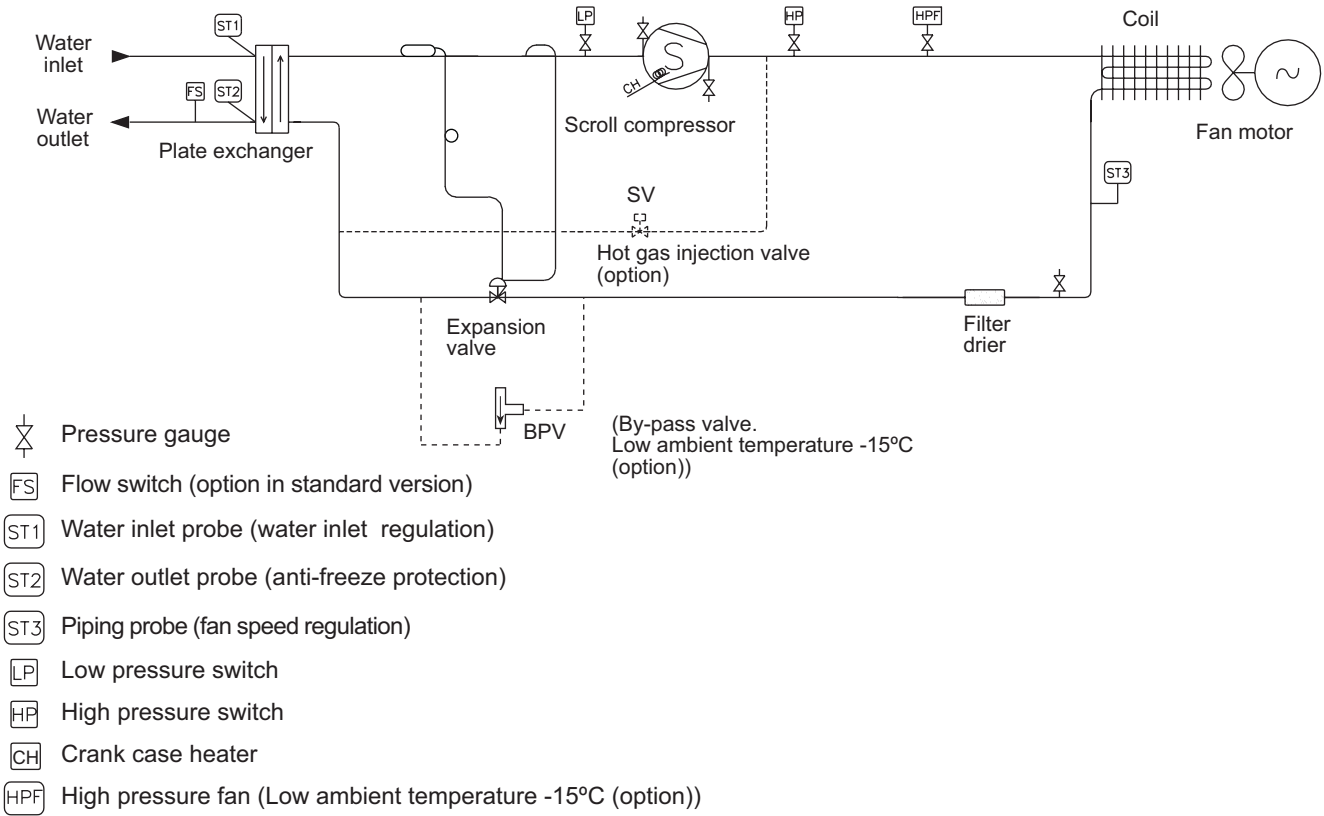

COOLING ONLY UNITS EAC 0472S TO 0812S

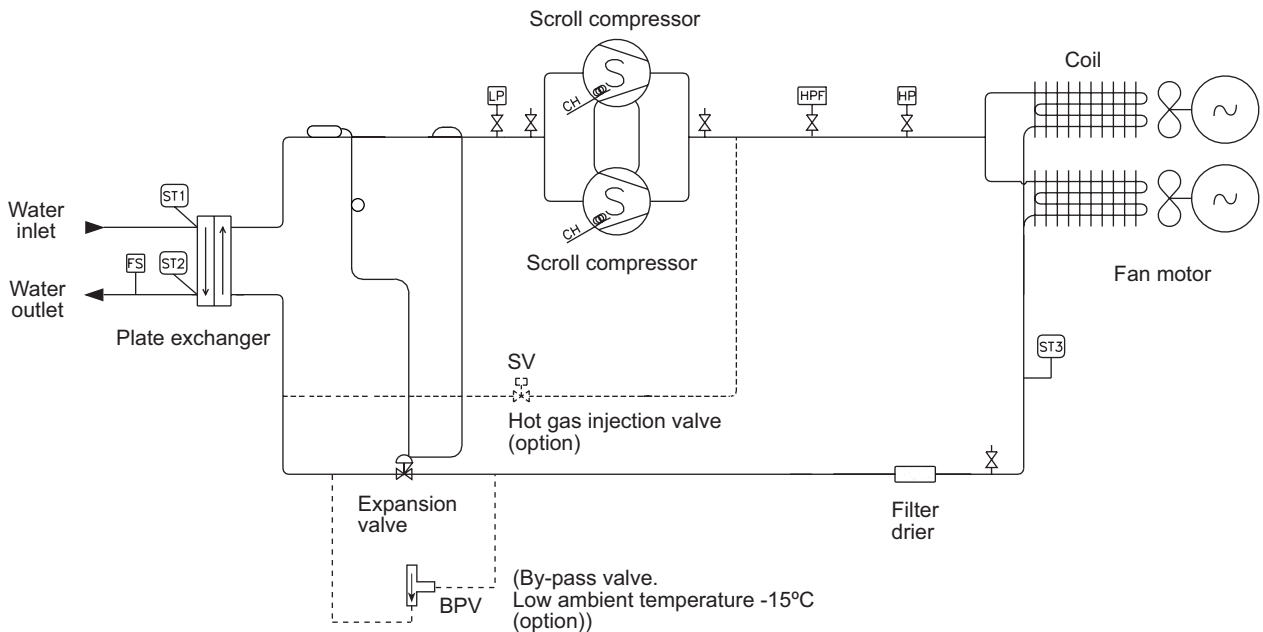







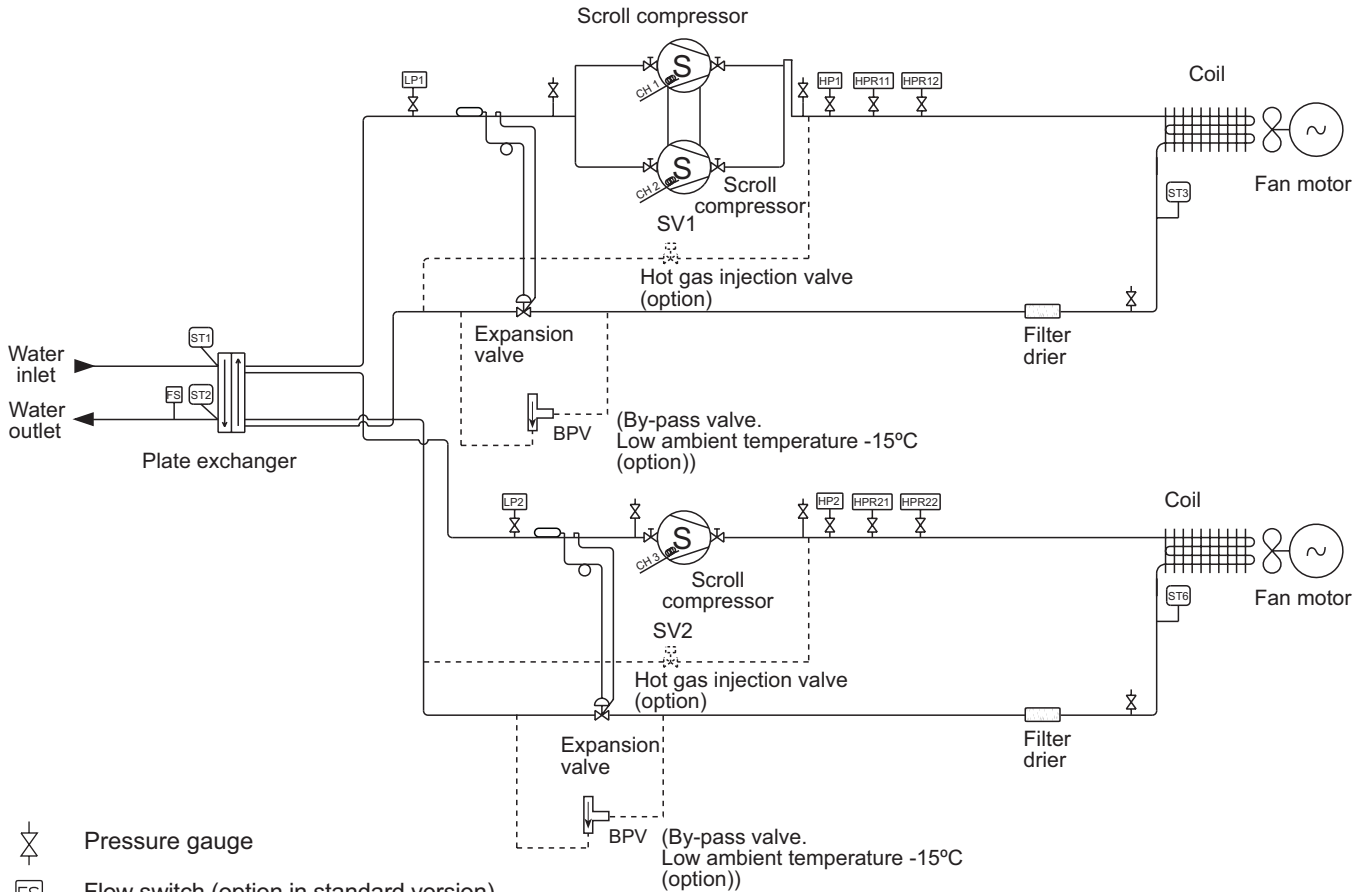









1.- GENERAL CHARACTERISTICS

1.8.- PIPING DRAWINGS

COOLING ONLY UNITS EAC 1003S TO 1303S



-  Pressure gauge
-  Flow switch (option in standard version)
-  Water inlet probe (water inlet regulation)
-  Water outlet probe (anti-freeze protection)
-  Piping probe circuit 1 (condensing temperature visualization)
-  Piping probe circuit 2 (condensing temperature visualization)
-  Low pressure switch cooling cycle circuit 1
-  Low pressure switch cooling cycle circuit 2
-  High pressure switch circuit 1
-  High pressure switch circuit 2
-  Condensing pressure control ON/OFF fan motor
-  Condensing pressure control. Low/high speed
-  Condensing pressure control ON/OFF fan motor
-  Condensing pressure control. Low/high speed
-  Crank case heater
-  Crank case heater
-  Crank case heater

1.- GENERAL CHARACTERISTICS

1.8.- PIPING DRAWINGS HEAT PUMP UNITS EAR 0091S TO 0431S

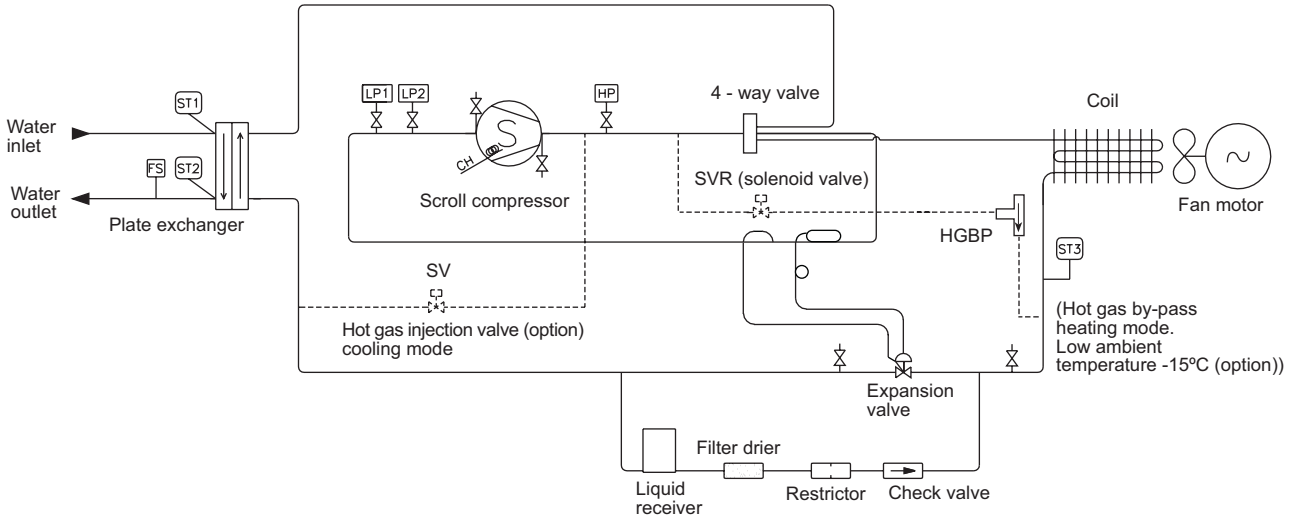

- | | | | |
|--|---|--|---|
| | Pressure gauge | | Low pressure switch cooling cycle circuit 1 |
| | Flow switch (option in standard version) | | Low pressure switch heating cycle circuit 1 |
| | Water inlet probe (water inlet regulation) | | Low pressure switch cooling cycle circuit 2 |
| | Water outlet probe (anti-freeze protection) | | Low pressure switch heating cycle circuit 2 |
| | Piping probe circuit 1 (fan speed regulation and defrost heat pump units) | | High pressure switch |
| | Piping probe circuit 2 (fan speed regulation and defrost heat pump units) | | High pressure switch circuit 1 |
| | Low pressure switch cooling cycle | | High pressure switch circuit 2 |
| | Low pressure switch heating cycle | | End pressure defrost circuit 1 |
| | Crank case heater | | End pressure defrost circuit 2 |

HEAT PUMP UNITS EAR 0472S TO 0812S

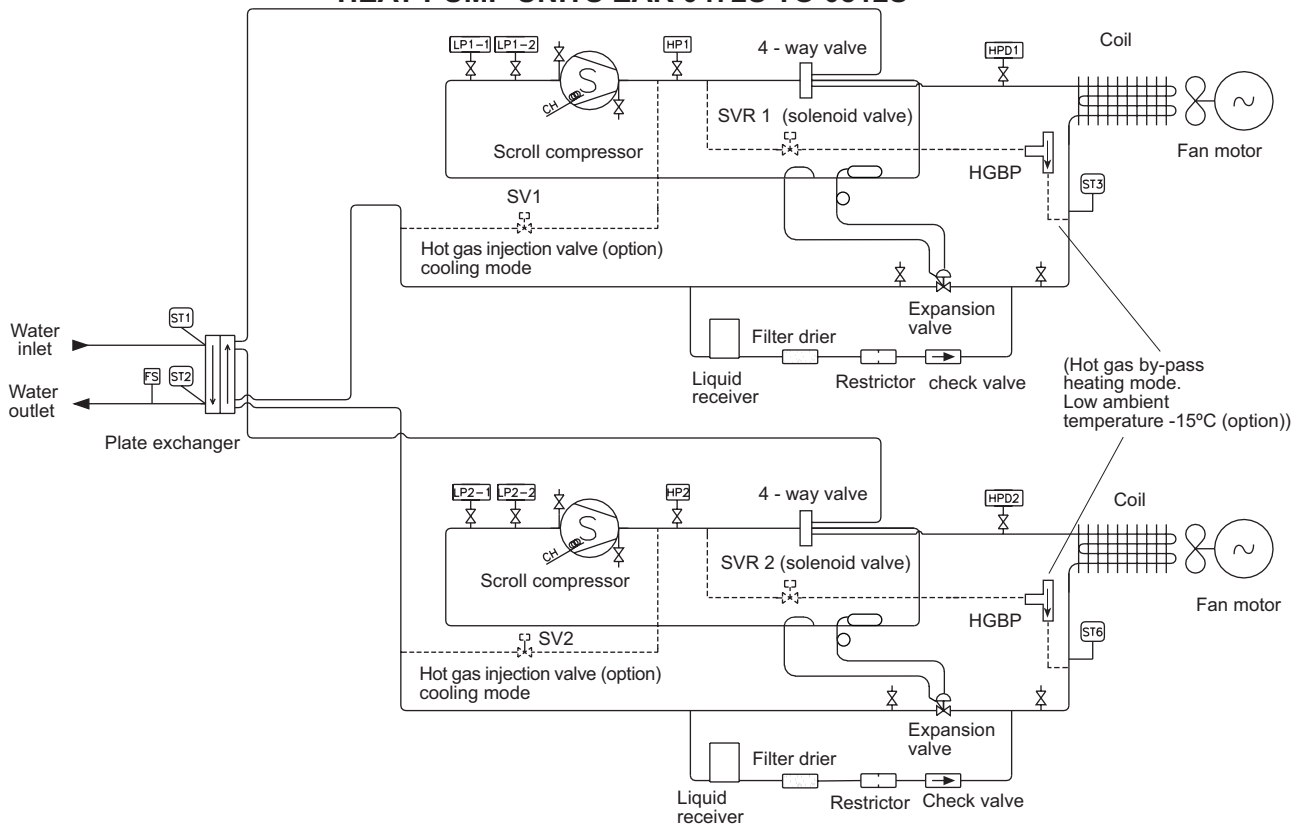

1.- GENERAL CHARACTERISTICS

1.8.- PIPING DRAWINGS

HEAT PUMP UNITS EAR 1003S TO 1303S

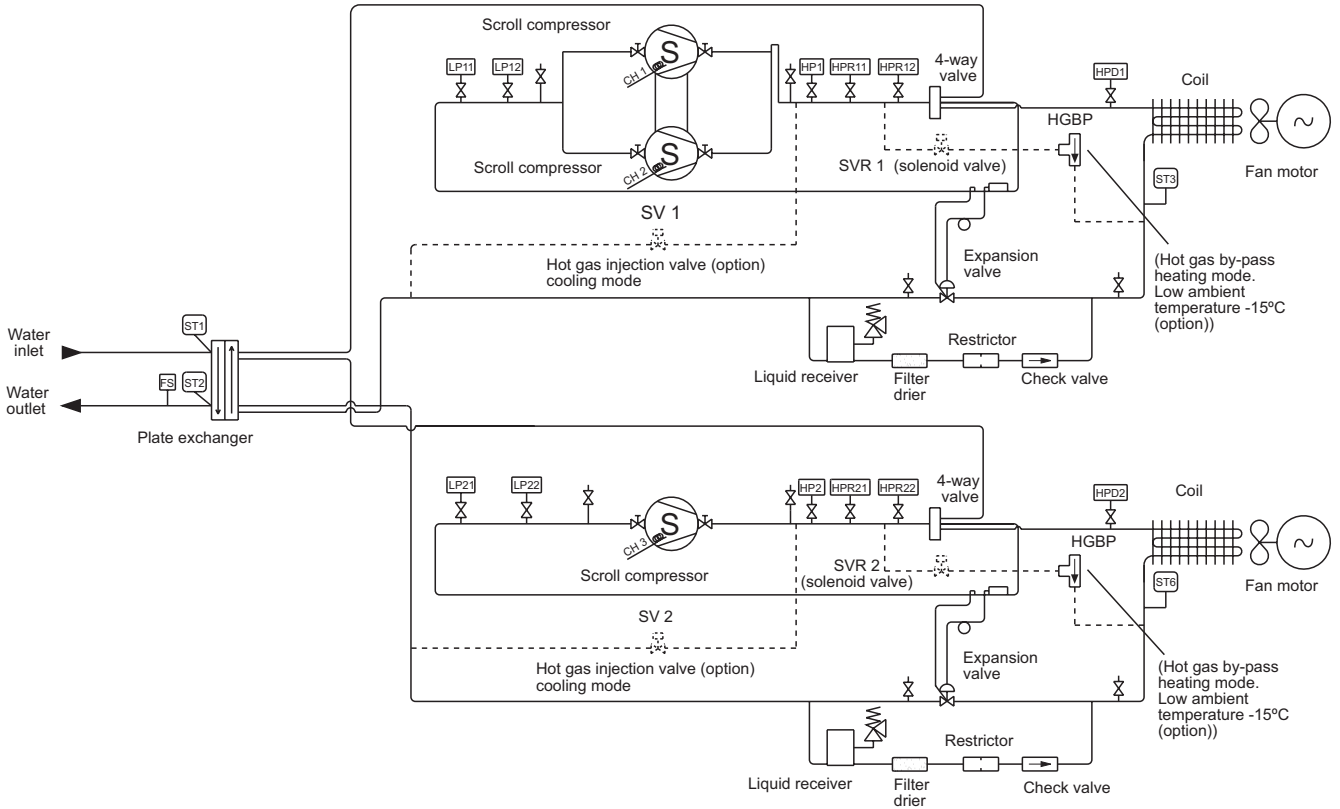

- | | | | |
|--|--|--|--|
| | Pressure gauge | | Condensing pressure control ON/OFF fan motor |
| | Flow switch (option in standard version) | | Condensing pressure control. Low/high speed |
| | Water inlet probe (water inlet regulation) | | Low pressure switch cooling cycle circuit 1 |
| | Water outlet probe (anti-freeze protection) | | Low pressure switch heating cycle circuit 1 |
| | Piping probe circuit 1 (defrost temperature) | | Low pressure switch cooling cycle circuit 2 |
| | Piping probe circuit 2 (defrost temperature) | | Low pressure switch heating cycle circuit 2 |
| | Crank case heater | | High pressure switch circuit 1 |
| | Crank case heater | | High pressure switch circuit 2 |
| | Crank case heater | | End pressure defrost circuit 1 |
| | Condensing pressure control ON/OFF fan motor | | End pressure defrost circuit 2 |
| | Condensing pressure control. Low/high speed | | |

1.- GENERAL CHARACTERISTICS

1.9.- DIMENSIONS

**EAC/EAR
0091S**

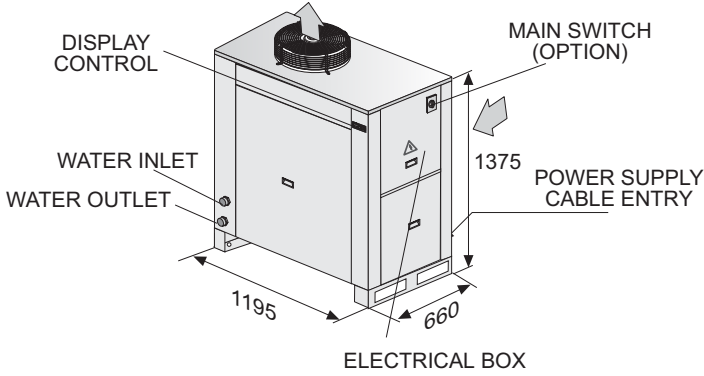

**COMPONENT DISPOSITION
STANDARD UNIT**

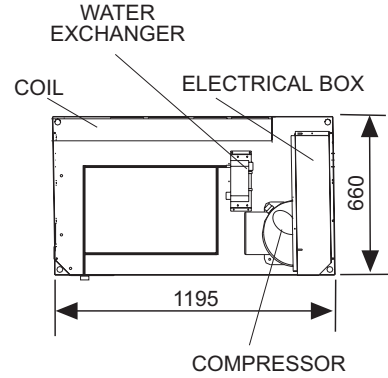

**EAC/EAR
0091S FP**

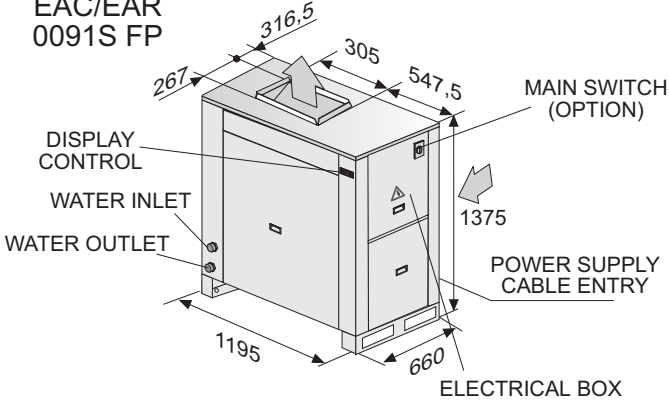

**COMPONENT DISPOSITION
STANDARD UNIT WITH
HYDRAULIC MODULE**

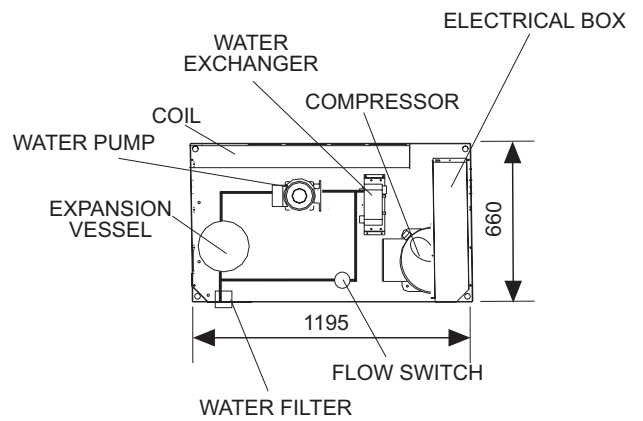

**EAC/EAR
0111S-0151S-0191S-0211S**

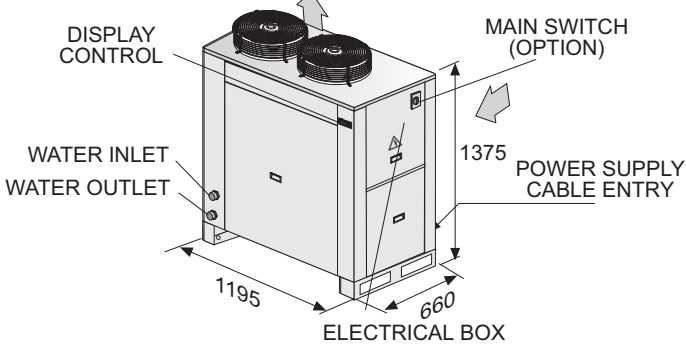

**COMPONENT DISPOSITION
STANDARD UNIT WITH
HYDRONIC MODULE**

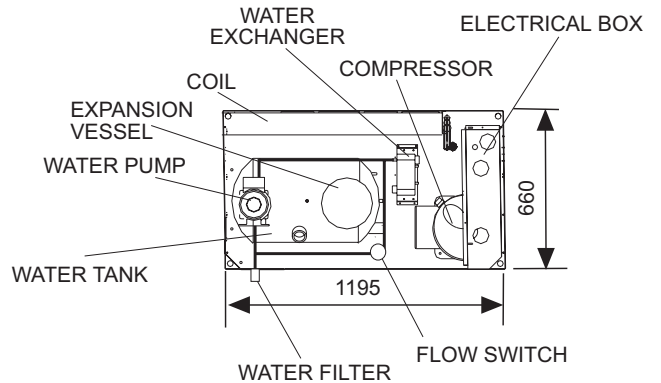

**EAC/EAR
0111S-0151S-0191S-0211S FP**

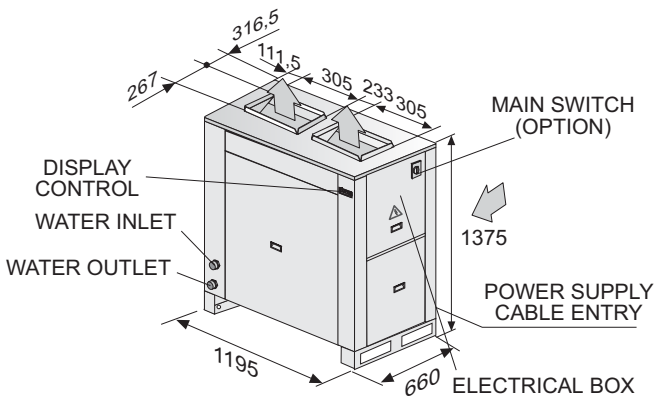

1.- GENERAL CHARACTERISTICS

1.9.- DIMENSIONS

EAC/EAR
0251S-0291S-0351S-0431S

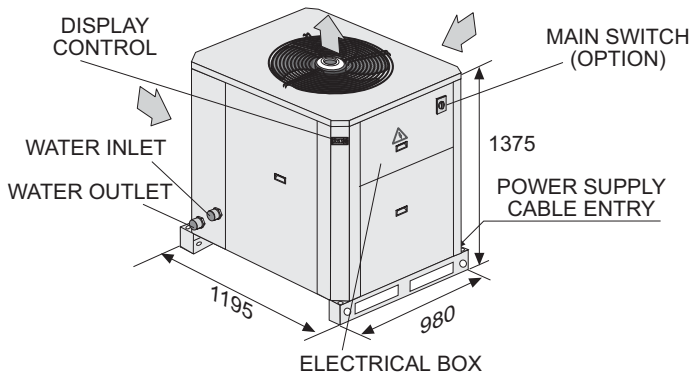

EAC/EAR
0251S-0291S-0351S-0431S FP1/FP2

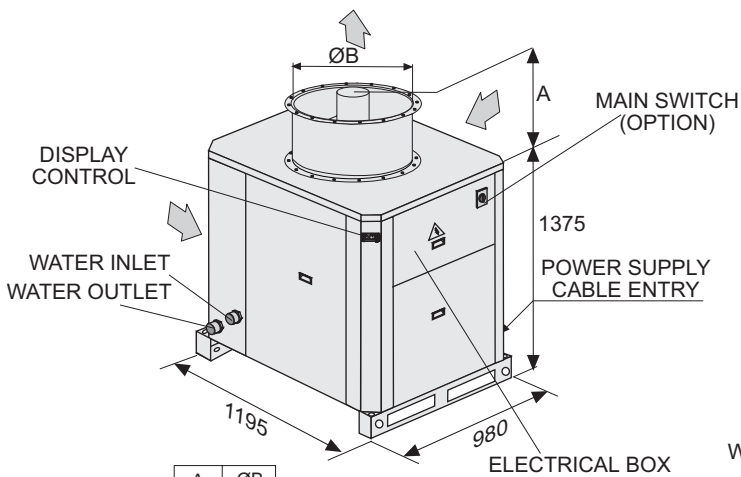

	A	ØB
FP1 version	240	630
FP2 version	425	710

COMPONENT DISPOSITION
STANDARD UNIT

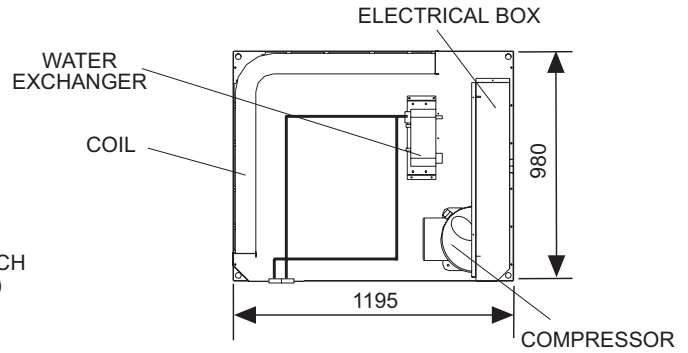

COMPONENT DISPOSITION
STANDARD UNIT WITH
HYDRAULIC MODULE

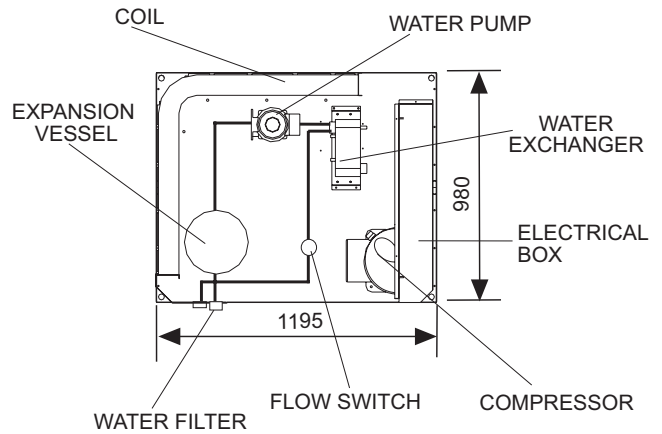

COMPONENT DISPOSITION
STANDARD UNIT WITH
HYDRONIC MODULE

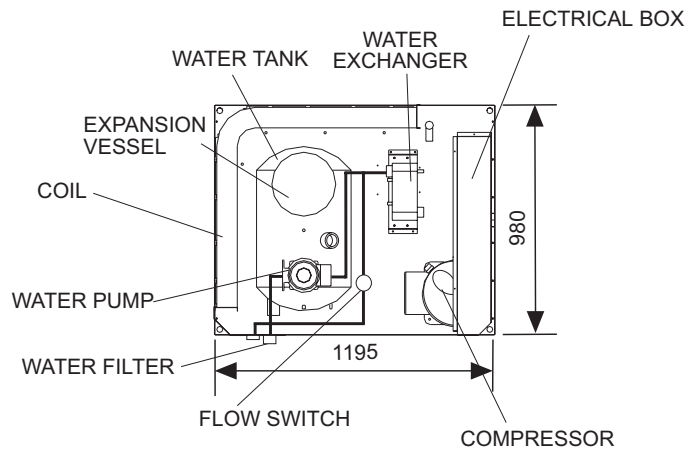

1.- GENERAL CHARACTERISTICS

1.9.- DIMENSIONS

EAC/EAR
0472S-0552S-0672S-0812S

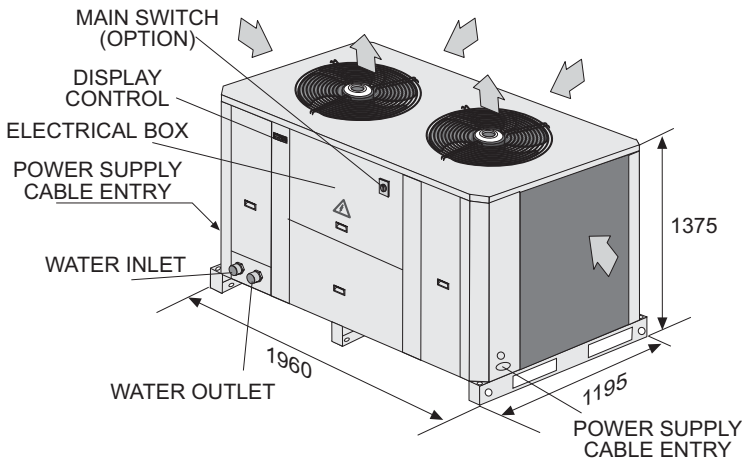

**COMPONENT DISPOSITION
STANDARD UNIT**

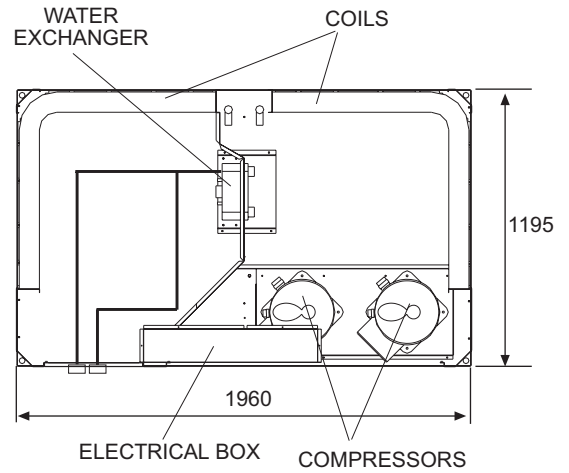

EAC/EAR
0472S-0552S-0672S-0812S FP1/FP2

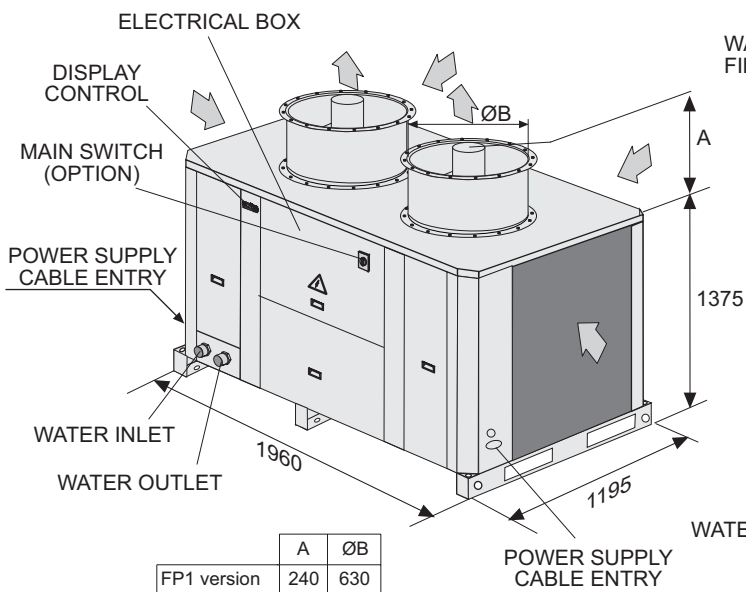

	A	ØB
FP1 version	240	630
FP2 version	425	710

**COMPONENT DISPOSITION
STANDARD UNIT WITH
HYDRAULIC MODULE**

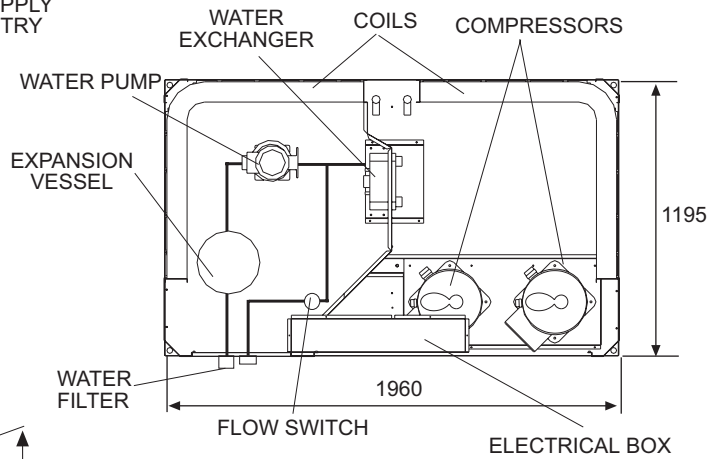

**COMPONENT DISPOSITION
STANDARD UNIT WITH
HYDRONIC MODULE**

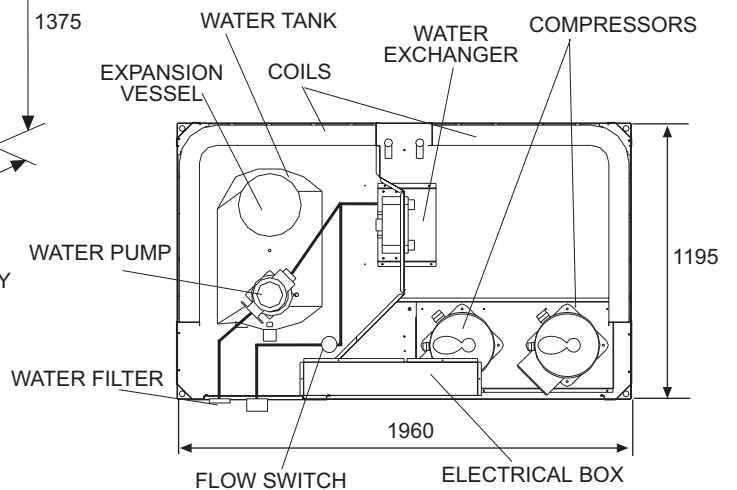

1.- GENERAL CHARACTERISTICS

1.9.- DIMENSIONS

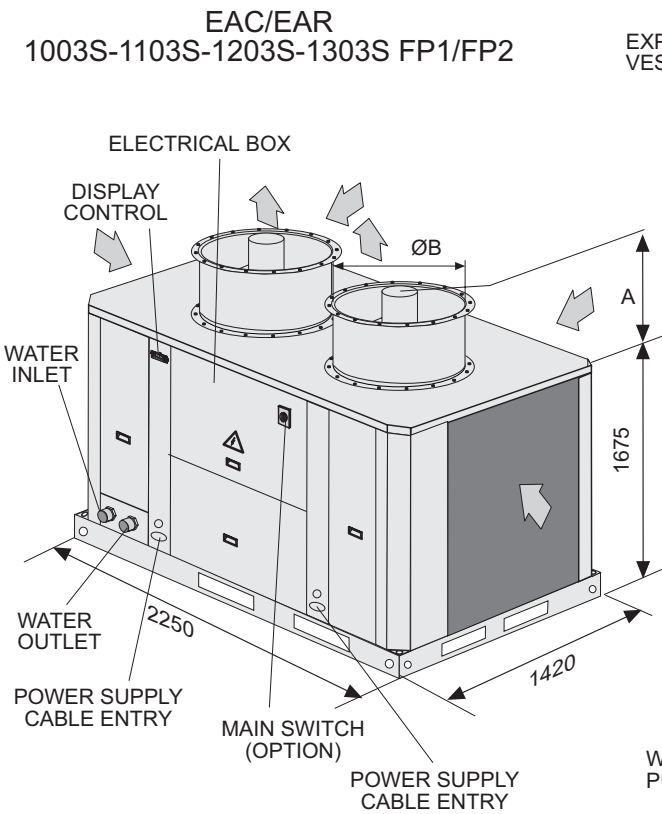
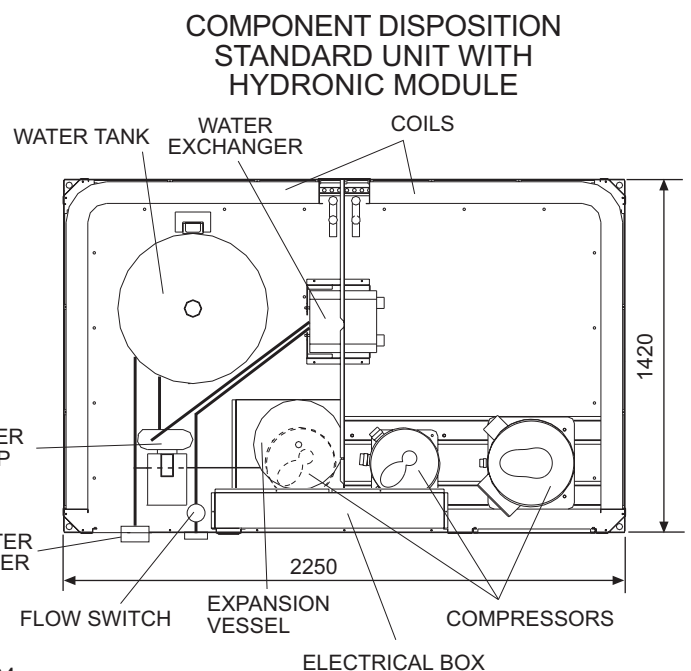
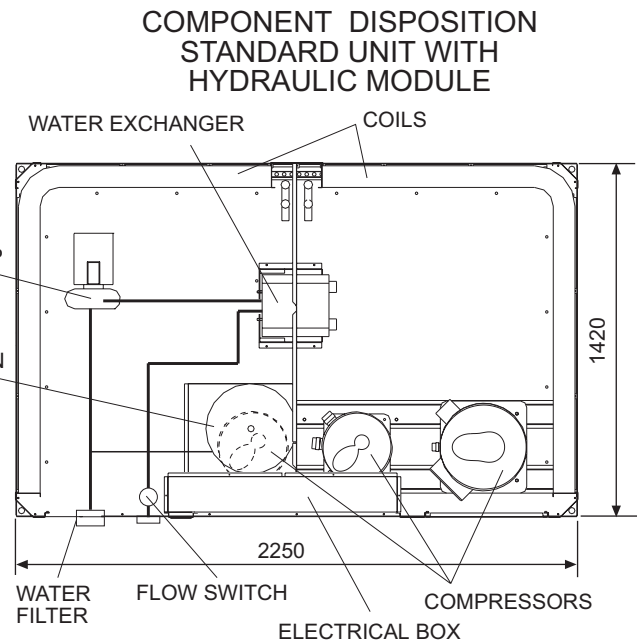
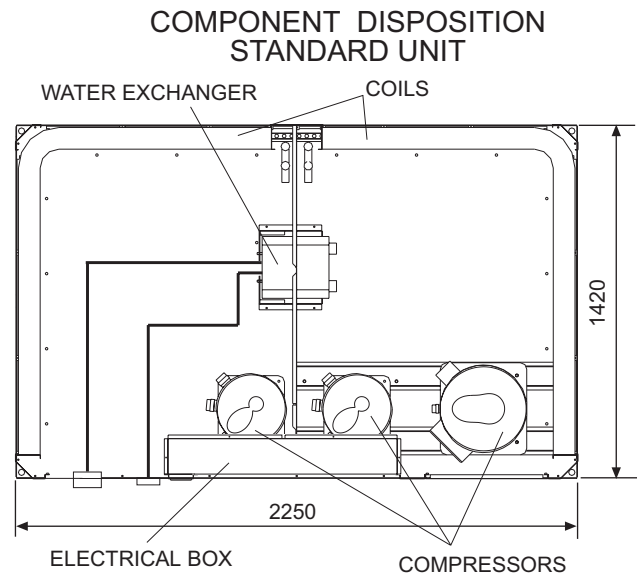
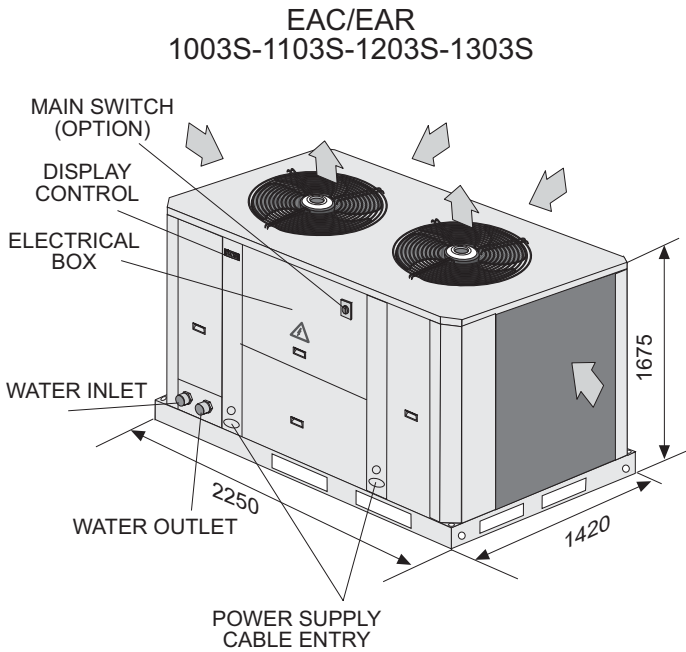

	A	ØB
FP1/FP2 version	280	800

1.- GENERAL CHARACTERISTICS

1.10.- OPTIONS

	Standard version unit	Hydraulic version unit	Hydronic (1) version unit
Main ON/OFF switch	X	X	X
Flow switch	X	included	included
Water filter	X	included	included
Evaporator anti freeze protection	X	X	X
Condenser protection guards	X	X	X
Thermostatic hot gas injection	X	X	X
Three phase protection (Three phase units)	X	X	X
HP and LP refrigerant gauges	X	X	X
Epoxy coated Al fin coils treated	X	X	X
Remote display	X	X	X
In/Out isolating valves	X	X	X
Anti-vibration mounts rubber	X	X	X
Compressor noise insulation jacket	X	X	X
"Soft starter" only 3N-400V units	X	X	X
Inlet plenum	X	X	X
Square discharge duct (2)	X	X	X
Low water temperature	X	X	X
Water pump	X	included	included
Twin pumps (6)	not available	X	X
Tank anti-freeze heater	not available	not available	X
Water tank electrical heater (3)	not available	not available	X
Heating low ambient kit (-15°C). EAR units	X	X	X
Low ambient kit (-15°C). EAC units (4)	X	X	X
BMS (Interface Mod-bus KP06+Bus Adapter)	X	X	X
Alarm relay (5)	X	X	X
Dynamic set point (7)	X	X	X

X Option element

(3) Only for heat pumps units.

(6) For models 0251 to 1303.

(1) Water tank included

(4) Not available for units EAC 0251 FP2 to 0812 FP2.

With twin pumps, water filter has to be mounted outside the unit (1003 to 1303 models)

(2) Only versions FP1/FP2

(5) Standard for models: EAR 0472 to 1303 /EAC 1003 to 1303.

(7) Not available for units EAC 0472 to 0812.



NOTE: All the option will be supplied and mounted in the unit, except the water filter, water isolation valves, rubber antivibration mounts, remote controller and air intake plenum supplied to mount in the moment of installation.

MAIN ON/OFF SWITCH

Located at the electrical box of the unit.

FLOW SWITCH (included on Hydraulic and Hydronic versions)

The flow switch stops the unit if water flow is lower than the minimum.

WATER FILTER (included on Hydraulic and Hydronic versions)

The water filter must be fitted in the water inlet of the unit, it protects the unit against particles (greater than 1 mm) getting inside the water circuit, and prevents the water interchanger gets dirty.

EVAPORATOR ANTI FREEZE PROTECTION

The evaporator anti freeze heater prevents the water exchange from low temperatures.

CONDENSER PROTECTION GUARDS

The condenser coil protection grill prevents light damage to the coil when shipping and when installed. It cannot protect against very heavy impacts.

THERMOSTATIC HOT GAS INJECTION

Supplies hot gas which is injected into the evaporator gas to increase the suction pressure if the chilled water temperature falls to low. It can be used to allow the unit to operate at reduced capacity, if the water temperature falls below the set point (5°C). It is controlled via the microprocessor controller ON at (5°C) and OFF (6°C) for example. This option is NOT available for units selected with low water temperature option.

THREE PHASE PROTECTION

Located at the electrical box of the unit, it assures that unit will not begin operation if connection phases of compressor are not correct. Should this occur, then just switch two phase connections.

HP AND LP REFRIGERANT GAUGES

Visualize the high and low pressures of the refrigerant circuit.

EPOXY COATED ALUMINIUM FIN COILS TREATED

Special protection of the aluminium condenser coil fins, to give improved protection from aggressive external environmental conditions.

REMOTE DISPLAY

Controls and visualizes the unit's operating, it may be installed until 50 m from the unit.

HEATING LOW AMBIENT KIT (-15°C)

The reverse unit can operate in heating mode down to an ambient temperature of -15°C (standard unit just can operate down to -10°C).

LOW AMBIENT KIT (-15°C)

The cooling only unit can operate down to an ambient temperature of -15°C (standard unit just can operate down to 0°C).

IN/OUT ISOLATING VALVES

To fit at inlet and water outlet of the unit. Isolating the unit from water circuit, so service and maintenance of the unit will be easier.

For units EAC 1003-1303 SKHN this option includes another valve in order to isolate the buffer tank.

ANTI-VIBRATION MOUNTS RUBBER

To install under the unit, to avoid transmission of vibrations, to the floor where unit is installed, while unit is operating.

1.- GENERAL CHARACTERISTICS

1.10.- OPTIONS

COMPRESSOR NOISE INSULATION JACKET

Each compressor is fitted with a compressor acoustic jacket this provides attenuation of the compressor noise that radiates from the unit when in operation.

SOFT STARTER (for 3N~400V units only)

It is an electronic element, which reduces the peak compressor starting current up to 40%.

INLET PLENUM (models from 0251 to 1303 only)

It is a accessory for adapting the condenser air intake to accept a duct.

SQUARE DISCHARGE DUCT (FP1 and FP2 unit versions and models from 0251 to 1303 only)

It is formed by 1 or 2 square frames, for adapting discharge air from the unit to a square duct.

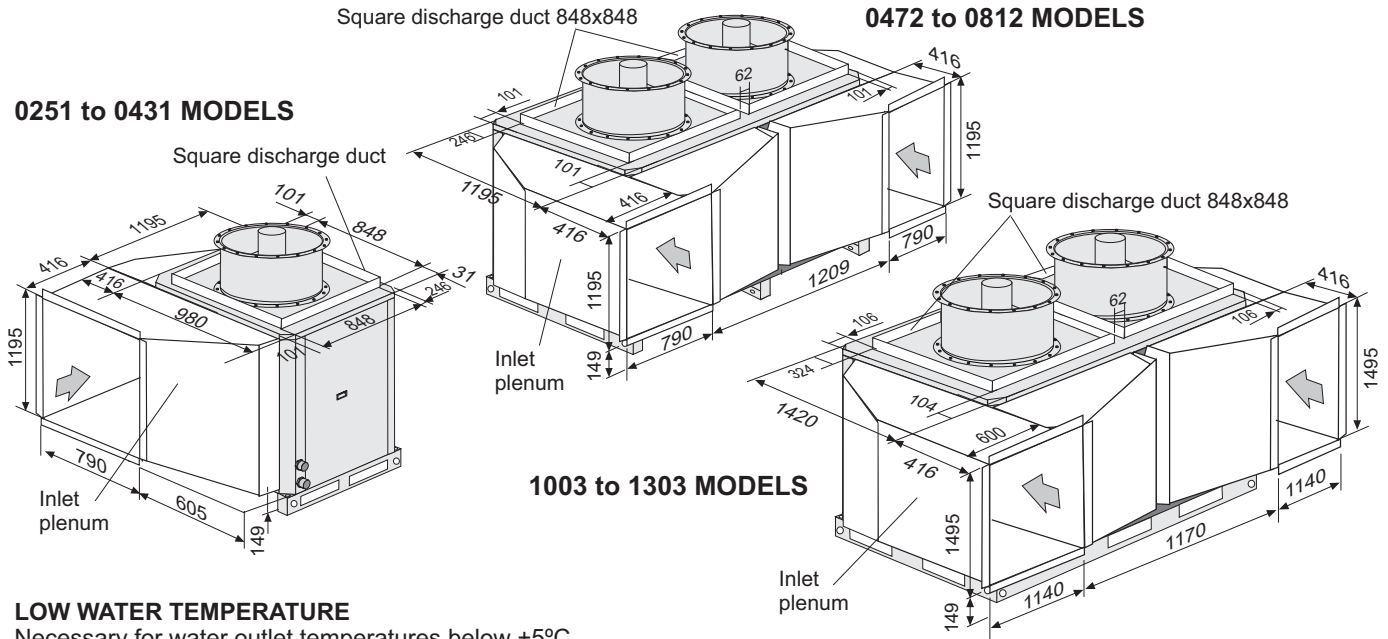

LOW WATER TEMPERATURE

Necessary for water outlet temperatures below +5°C

There are three different kits, which depend for selecting on the water outlet temperature desired, as the following table shows:

Denomination	Application duty on the water outlet temperature
KIT LOW WATER TEMPERATURE 0°C	For water temperatures below 5°C to 0°C
KIT LOW WATER TEMPERATURE -5°C	For water temperatures below 0°C to -5°C
KIT LOW WATER TEMPERATURE -10°C	For water temperatures below -5°C to -10°C

WATER PUMP (included on Hydraulic and Hydronic versions).

TWIN PUMPS KIT (models from 0251 to 1303 only)

It is formed by two-water pumps mounted in parallel and with same characteristics as a single pump. Only one pump is working, the other remains on stand by.

When the water pump which is operating cuts out, and the pump turns off, automatically starting the water pump on stand by.

It is possible to select which one of the pumps we want to be working through an external switch supplied with the kit.

With the twin pumps, the available static pressure will decrease 5% from the available static pressure with one water pump only.

TANK ANTI-FREEZE HEATER AND WATER TANK ELECTRICAL HEATER (available only for Hydronic version): an immersion heater can be supplied complete with safety thermostat and pressure switch fitted in the buffer tank, or an anti-freeze and supplementary heater (heat pump units only).

Tank anti-freeze heater: It starts when water temperature in the buffer tank is lower than +5°C (Not for units with low water temperature kit).

Water tank electrical heater: heat pump units only. The heater works as anti-freeze heater as explained before and as supplementary heater, when inlet warm water reaches a temperature below a value selected (example: 30°C) through an independent thermostat included.

THE POWER INPUT IS:

Models	0091/0211	0251/0431	0472/0812	1003/1303
Voltage	1N~230V	3~230V - 3~400V		3~400V
Tank anti-freeze heater	2,25	2,25	2,25	6
Water tank electrical heater*	6	9	12	24

(*) Heat pump units only

BMS (Interface Mod-bus KP06+Bus Adapter)

It is possible to connect several units with a communication system (MOD BUS Protocol).

ALARM RELAY

It is a free voltage contact which indicates a general alarm in the unit.

DYNAMIC SET POINT (Not available for units EAC 0472 to 0812).

It changes cooling and heating set point according ambient temperature (an extra sensor must be installed).

2.- INSTALLATION

2.1.- SITE AND SHIPPING GUIDANCE



All INSTALLATION, SERVICE and MAINTENANCE operations must be carried out by QUALIFIED PERSONNEL.

The unit must be transported in a HORIZONTAL POSITION on its metal bedplate profiles . Any other position may cause serious damage to the machine.

When the unit is received, it should be checked to assure that there are no bumps or other damage, following the instructions on the packaging. If there is damage, the unit may be rejected by notifying the LENNOX Distribution Department and reporting why the machine is unacceptable on the transport agent's delivery notice. Any later complaint or claim made to the LENNOX Distribution Department, for this type of anomaly, cannot be considered under the Guarantee.

Sufficient space must be allowed to facilitate placement of the unit. The unit may be mounted outdoors. There should be adequate drainage around the unit.

In heat pump units during defrost cycle, the units produce a great amount of water melting the ice off coils. If you wish to drain the water, adequate drainage should be installed behind the unit to collect and carry out the water where desired.



When positioning the unit, be sure that the Rating Plate will always be visible since this data will be necessary to assure proper maintenance.

It is advisable to unpack the unit at the place where the unit is going to be installed, to avoid damages during manage.

2.2.- UNIT LIFTING

How to hoist the unit

If unloading and placement requires the use of a crane, then secure the suspension cables as shown in the figure. The unit can only be lifted and moved by its base.

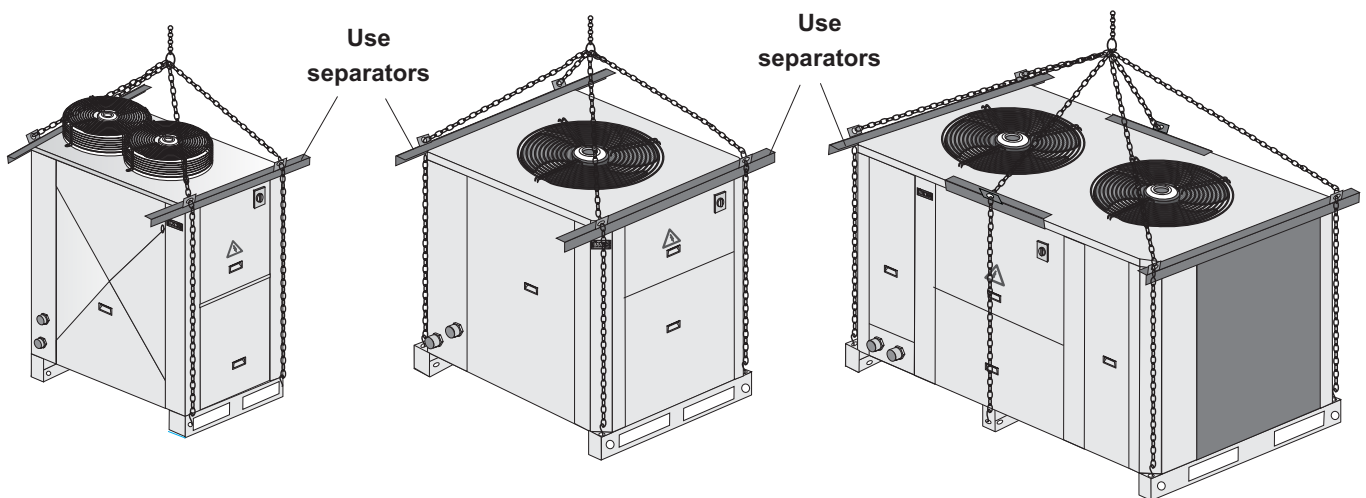

2.- INSTALLATION

2.3.- ANTIVIBRATION MOUNTING

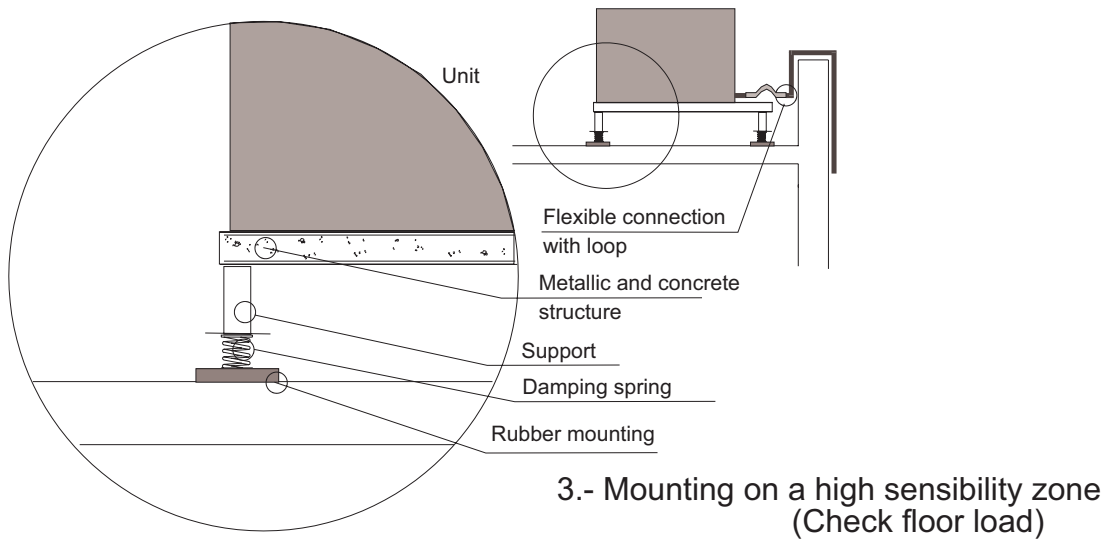
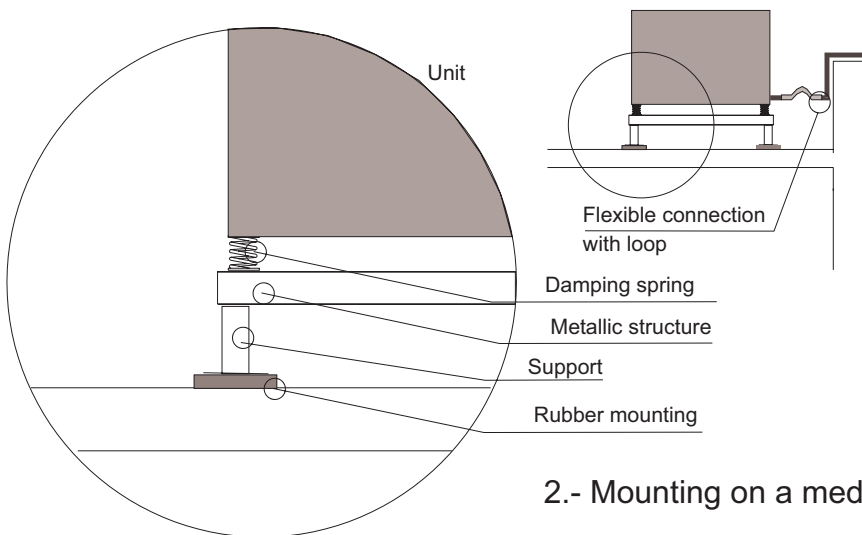
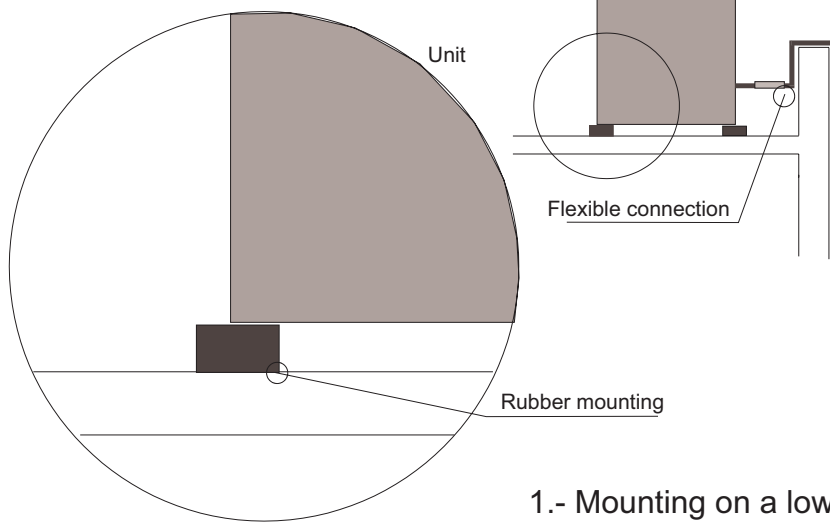

2.- INSTALLATION

2.4.- INSTALLATION CLEARANCES

(*) Clearance around the unit, for all unit versions.

Failure to install the units as shown will impact performance and reliability.

INSTALLATION CLEARANCES

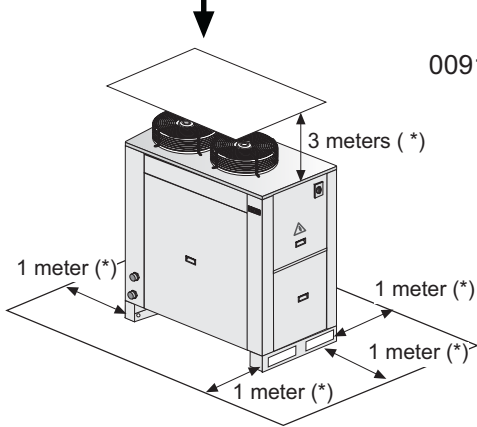

EAC/EAR
0091S-0111S-0151S-0191S-0211S

DETAILING AVM POSITIONS

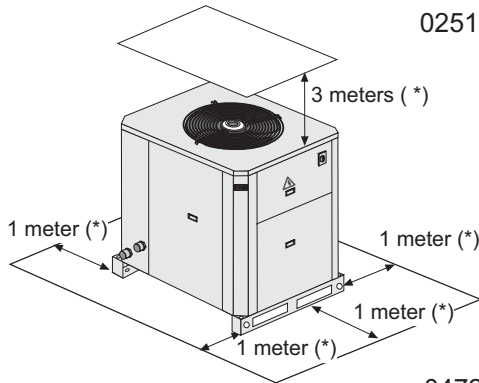
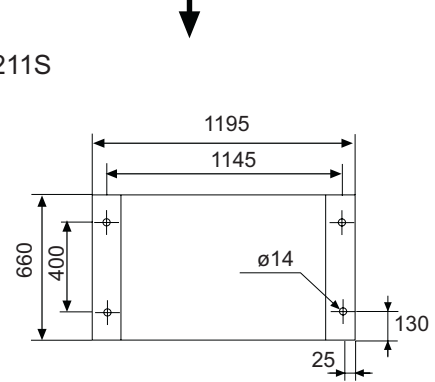

EAC/EAR
0251S-0291S-0351S-0431S

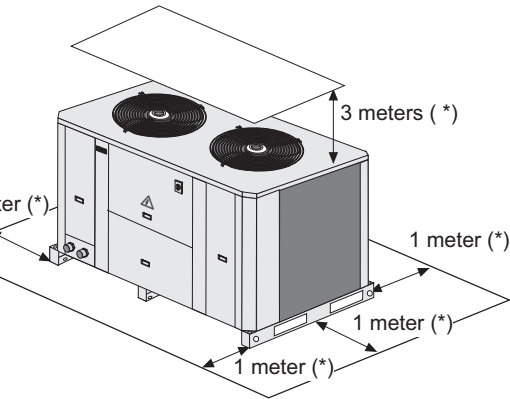
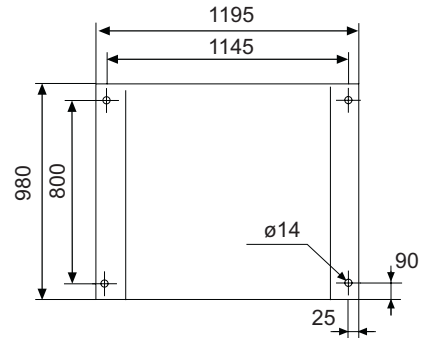

EAC/EAR
0472S-0552S-0672S-0812S

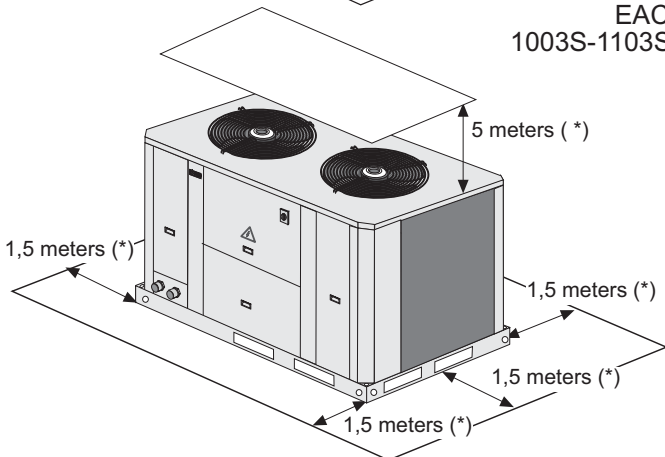
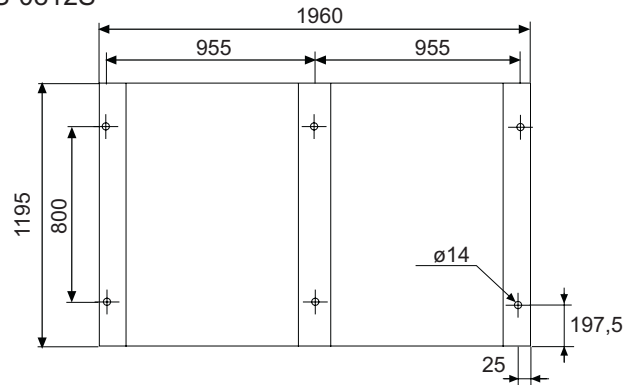

EAC/EAR
1003S-1103S-1203S-1303S

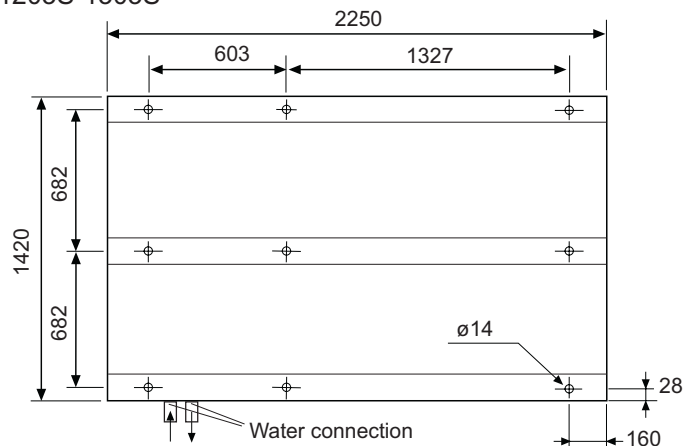

sizes in mm

2.- INSTALLATION

2.5.- UNIT INSTALLATION

- 1.- The EcoLean™ units could be installed outside or inside.
- 2.- See the minimum clearance diagrams for access - air supply to the batteries in the heating section of the unit. (see page 29)
- 3.- Assemble the unit on a resistant base, preferably concrete. To prevent vibrations, the concrete base should not come into contact with the building's foundations.
- 4.- It is advisable to assemble the unit on shock absorbers (antivibration mountings).
- 5.- During heating mode (heating pump coolers) ice forms in the coils. The defrost process is activated during heating mode in heat pump units, when the outside temperature is low and the outdoor coil could become frozen.

To melt the ice, the defrost function will switch the unit to cooling operation for a short period. When the evaporation temperature starts to drop, a defrost period sets in to provide sufficient heat transfer. During defrosting, the ice melts from the batteries. As a result, the ice contains water which must be removed.



WARNING

If the unit is exposed for long periods to installation conditions below 0°C the water from defrost can freeze in the base of the unit. This prevents drainage. Ice build up can occur preventing correct operation. For these conditions contact customer service team.

- 6.- The heat exchanger water flow during cooling must be the same as during heating.
- 7.- Fit a water filter in the unit inlet.



It is obligatory to install a mesh filter in units not equipped with Hydronic or Hydraulic module. The step of the mesh should not be superior to 1 mm.

- 8.- Use water treating if necessary.
- 9.- The water inlet to the circuit has to be filled from lowest point, with purges opened, to prevent air being trapped.
- 10.- Location inside:

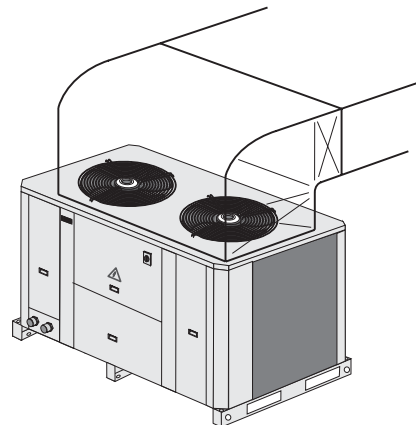
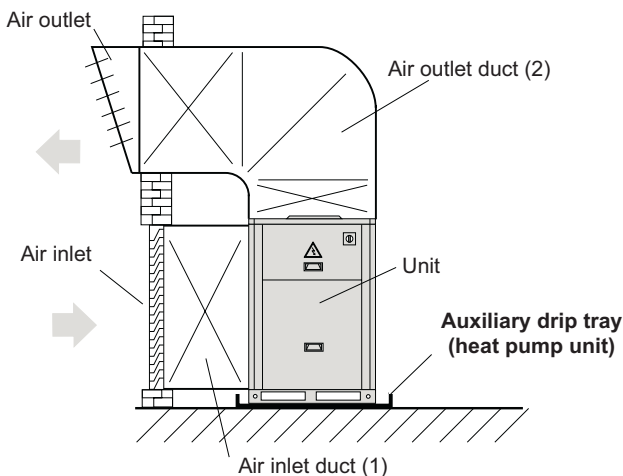

In heat pump units with double circuits and cooling only units 1003S to 1303S, if only one duct is going to be installed, a regulated pressure damper should be installed for each fan, to avoid air by-pass through the fan if it has stopped.

For location inside, keep in mind following advice:

- In heat pump units during defrost cycle, the units produce a great amount of water melting the ice off coils. If you wish to drain the water, adequate drainage should be installed below the unit to collect and carry out the water where desired.

- Air duct installation:

If air duct has been installed, the operating limits get reduced (see operation limits section in this manual).

(1) The air intake plenum (option) available for models from 0251 to 1303 makes easier the installation of the air intake duct (see page 26).

(2) The discharge plenum (option) lets the installation of a square discharge duct for the high static pressure units FP1 and FP2 (see page 26).

2.- INSTALLATION

2.5.- UNIT INSTALLATION

- 11.- For cooling or heat pump units the hydraulic system must contain the following components pump, buffer tank, expansion device, safety valve, water filter, flow switch.
- 12.- To obtain the total water system pressure drop add the unit pressure drop + water pipework + fittings and terminal unit pressure drops the water pump can be selected to provide the correct water flow across the heat exchanger.
- 13.- A water balancing valve is advised to ensure correct water flow.

IMPORTANT



If the outside temperature in the area where the EcoLean™ unit is to be installed is likely to drop below 5°C, it is very important to take the following precautions to avoid that water in the circuit freezing, that may produce damage to the components.

-If unit has to work under low outside temperatures:

* Do not disconnect power supply in order that water pump starts when detects water temperatures below +5 °C (only Hydraulic and Hydronic models).

* If the outside temperature where the system is to be installed or the water outlet temperature is likely to drop below 5°C, it is very important to use glycol anti-freeze.

The amount of anti-freeze required will vary depending on the minimum ambient temperature or the water outlet temperature.

When the percentage of glycol increases the standard pump flow decreases, the pressure drop increases and the cooling and thermal capacities drop. As a result the minimum flow must be multiplied by the coefficient shown in the table:

MINIMUM AMBIENT TEMPERATURE OR WATER OUTLET TEMPERATURE	ETHYLENE GLYCOL %	PRESSURE DROP	WATER FLOW	CAPACITIES	
				COOL	HEAT
FROM +5°C TO 0°C	10 %	1,05	1,02	0,99	0,994
FROM 0°C TO -5°C	20 %	1,10	1,05	0,98	0,993
FROM -5°C TO -10°C	30 %	1,15	1,08	0,97	0,99
FROM -10°C TO -15°C	35 %	1,18	1,10	0,96	0,987

Example: 10 % glycol in EAC0091SKHN

Minimum flow: $1,19 \text{ m}^3/\text{h} \times 1,02$

Pressure drop $\times 1,07$

System capacity $\times 0,99$

Also is advisable to use the option "evaporator anti freeze protection"

Failure to follow this advice, may result in damage to the installation.

Optionally, an immersion heater can be supplied complete with safety thermostat and pressure switch fitted in the buffer tank of the cooling only chiller. A similar option is available for heat pump versions with the added advantage of a supplementary heating source (Hydronic version units).

2.- INSTALLATION

2.6.- ELECTRICAL CONNECTIONS



- BEFORE MAKING ANY ELECTRICAL CONNECTIONS, BE SURE THAT ALL CIRCUIT BREAKERS ARE OPEN AND SUPPLY IS OFF.
- IN ORDER TO CARRY OUT THE ELECTRICAL CONNECTIONS, FOLLOW THE ELECTRICAL DIAGRAM SUPPLIED WITH THE UNIT

POWER SUPPLY	230V SINGLE PHASE UNITS		230V THREE-PHASE UNITS		400V THREE-PHASE UNITS	
	1N ~ 230V - 50 Hz + PE		3 ~ 230V - 50 Hz + PE		3N ~ 400V - 50 Hz + PE	
UNIT MODEL	NUMBER OF WIRES X SECTION		Without AEH		With AEH	
	Without AEH	With AEH	Without AEH	With AEH	Without AEH	With AEH
0091S	3 x 4 mm ²	3 x 10 mm ²	4 x 4 mm ²	4 x 6 mm ²	5 x 2,5 mm ²	5 x 4 mm ²
0111S	---	---	4 x 4 mm ²	4 x 6 mm ²	5 x 2,5 mm ²	5 x 4 mm ²
0151S	---	---	4 x 6 mm ²	4 x 10 mm ²	5 x 4 mm ²	5 x 4 mm ²
0191S	---	---	4 x 10 mm ²	4 x 10 mm ²	5 x 4 mm ²	5 x 4 mm ²
0211S	---	---	4 x 10 mm ²	4 x 10 mm ²	5 x 4 mm ²	5 x 4 mm ²
0251S	---	---	4 x 10 mm ²	4 x 10 mm ²	5 x 4 mm ²	5 x 6 mm ²
0291S	---	---	4 x 10 mm ²	4 x 16 mm ²	5 x 6 mm ²	5 x 10 mm ²
0351S	---	---	4 x 16 mm ²	4 x 25 mm ²	5 x 10 mm ²	5 x 10 mm ²
0431S	---	---	4 x 16 mm ²	4 x 25 mm ²	5 x 10 mm ²	5 x 10 mm ²
0472S	---	---	4 x 25 mm ²	4 x 35 mm ²	5 x 10 mm ²	5 x 16 mm ²
0552S	---	---	4 x 25 mm ²	4 x 35 mm ²	5 x 16 mm ²	5 x 16 mm ²
0672S	---	---	4 x 35 mm ²	4 x 50 mm ²	5 x 16 mm ²	5 x 25 mm ²
0812S	---	---	4 x 50 mm ²	4 x 50 mm ²	5 x 16 mm ²	5 x 25 mm ²
1003S	---	---	---	---	5 x 25 mm ²	5 x 50 mm ²
1103S	---	---	---	---	5 x 35 mm ²	5 x 50 mm ²
1203S	---	---	---	---	5 x 35 mm ²	5 x 50 mm ²
1303S	---	---	---	---	5 x 80 mm ²	5 x 70 mm ²

- AEH: Auxiliary Electric Heater
- The cable sections have been calculated based on a distance of 50m and variation of -10V. Do not start the unit if the drop is greater than this.
- The wiring and circuit breakers to be mounted in the installation must comply with the Regulations in force.
- Ground wires must be properly connected and have a greater length than the phase wires.

(EAC) 0091 TO 1303S

(EAR) 0472 TO 1303S

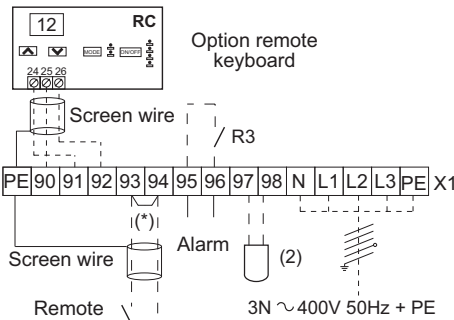

(EAR) 0091 TO 0431S

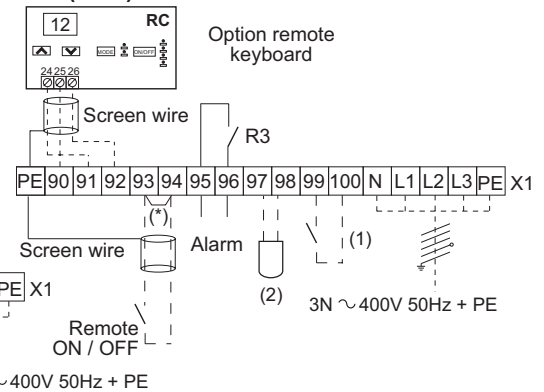
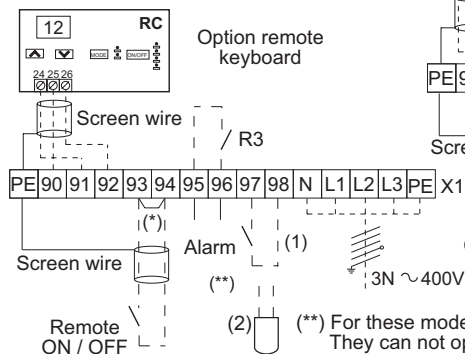

- (*) Remove wire.
 (1) Remote changeover summer-winter (Voltage free contact).
 (2) Dynamic set point (outdoor sensor). Not available for units EAC 0472 to 0812.

(**) For these models it is needed choose between (1) and (2) functions. They can not operate simultaneously.

VOLTAGE OPERATION LIMITS

MODELS	VOLTAGE	LIMIT
009	1N~230V-50Hz	1N~198-264V-50Hz
009-011-015-019	3~230V-50Hz	3~180-242V-50Hz
	3N~400V-50Hz	3N~342-462V-50Hz
019-021-025-029-035-043-047-055-067-081	3~230V-50Hz	3~198-264V-50Hz
	3N~400V-50Hz	3N~342-462V-50Hz
100-110-120-130	3N~400V-50Hz	3N~342-462V-50Hz

A remote controller is offered as an option.
 To install this option remote controller proceed as follow:
 - Connect exactly as indicated in electrical diagram
 - The wire should not exceed 50 m.

The three cables for connection from the keypad to the power board must be kept separate from other cables, using an individual cable channel; and use shielded cables, with a cross-section of 1 mm².

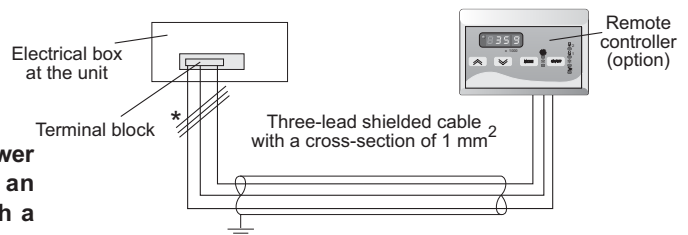

*Connection to be made by customer. MAXIMUM CABLE LENGTH 50m

3.- COMMISSIONING AND OPERATION

3.1.- STEPS TO FOLLOW FOR COMMISSIONING THE UNITS

PRE-START

Before commissioning the unit check the following:

- 1.- Check that the voltage is the same as the rated voltage on the specification plate.
 - 2.- Check that the supply to the control system is connected in accordance with the electrical diagram (if incorporates).
 - 3.- Check that the main switch is ON (if incorporates).
 - 4.- Make sure that the water connections are correct and have not been altered, as this can result in incorrect operation the flow divider will not operate if the connections are mixed.
 - 5.- Check that the fan can rotate freely.
 - 6.- Check the water pump's direction of rotation.
 - 7.- Check for air in the water system. Purge if necessary.
 - 8.- The compressor must not be started until the crankcase heater has been running for at least 8 hours.
- The compressor has a single phase electric heating element to assure a separation between the Refrigerant and the oil in the housing. This heater is activated when the compressor is off and stops working when the compressor is on.
About eight hours before start up or after a long shutdown period, voltage should be supplied to the unit so that this heater will be activated.
 - Check that the compressor starts after two minutes.
 - Select cool or heat as the operating mode at the control unit.
 - When the compressor starts the fans rotate at maximum speed for a short time. They then rotate in accordance with the condensation temperature/pressure.



REMEMBER THAT THE COMPRESSOR IS A SCROLL TYPE COMPRESSOR:

Before starting the unit, the compressor should be checked that rotates in the correct direction, through a three phase protection. Scroll type compressors only compress in one direction of the rotation. Single phase models are always started up in the proper direction; however, the three phase models, turn in either direction depending on the order of the power supply phases. Therefore, it is essential that the phase connection for scroll-type three-phase compressors be carried out correctly (the correct direction of rotation can be checked when the pressure on the suction side decreases and the pressure on the discharge side increases when the compressor is activated). If the connection is wrong, the rotation will be reversed causing a high noise level and a reduction in the amount of current consumed. If this occurs, the compressor's internal protection system will operate in shutting down the unit. The solution is to disconnect, switch the wires between two of the phases and connect the three again).

- Occasionally, when compressor stops and starts, there is a metallic noise because of spirals of the compressor. This is normal.
- Check compressor oil level, sight glass included (on the sides of the compressor, the level should be between 1/4 and 3/4 in the sight glass, while during operation the level should be between 3/4 and full).
- Connect high and low pressure gauges and check that operating pressure values are normal.
- Measure electrical consumption for the unit and check that it is near what is indicated on the specification plate.
- Check the electrical consumption of the compressor and the fans with what is specified in the physical data sheets.
- In the case of a Heat Pump unit, make a cycle change on the Control Panel checking that the 4-way valve makes the change correctly. Check the pressure values in the new cycle.
- **Remember the low pressure switch is reset automatically and the high pressure switch is reset manually.**
- **Remember that low pressure switch is automatic reset, if it has 3 operations in one hour, it will be a manual reset, through the control of the unit.**

3.- COMMISSIONING AND OPERATION

3.2.- CHECKING THE WATER FLOW RATE

It is very important that the unit operates at the correct water flow rate. It is dangerous to leave the unit operating at a low flow rate as this could result in serious damage to components as well as the water exchanger. If the unit operates at too high a flow rate, this will also hinder optimum performance. The best way of determining the operating flow rate is to measure the temperature difference between the inlet and water outlet.

Checking the water flow rate (it is vital to measure the thermal peak) (Standard unit)

For nominal and minimum water flow the difference between the inlet and water outlet temperature should be 5°C (cooling and heating pump units in cooling cycle only) for an inlet temperature of 12°C, an outlet temperature of 7°C and an outside temperature of 35°C. If these conditions change, the unit capacity will also change and as a result for nominal flow the difference between the inlet and water outlet temperature will vary slightly from 5°C as can be seen in the following table, based on nominal flow rate.

△ T (water inlet temperature - water outlet temperature)							
Outside temperature °C							
Water output °C	15	20	25	30	35	40	45
7	6,1	5,8	5,5	5,3	5,0	4,7	4,4
9	6,5	6,2	5,9	5,6	5,3	5,0	4,7
11	7,0	6,7	6,4	6,0	5,7	5,4	5,0

If the unit must be started in the heating cycle and if you wish to operate at nominal cooling rate, the following shows the approximate differences between the inlet and water outlet temperatures for the various conditions.

△ T (water inlet temperature - water outlet temperature)					
Outside temperature °C W.B.					
Water output °C	-6	0	6	12	18
35	4,5	5,5	6,5	7,5	8,5
50	4	5	6	7	8

Note: The unit control system displays the inlet and water outlet temperature to be displayed. See the Control Description section.

Check that the correct water pump has been selected, taking into account the loss of pressure in the hydraulic system. It is dangerous to let the unit run at a low rate and any faults which may result will not be covered under warranty.

Do not start up the air conditioning units or the fan coils until the water temperature reaches the set temperature or use an automatic control device which cancels the air conditioning unit operation if the installation is not properly set.

When everything is operating normally, take a reading of all the data and fill out the Commissioning Sheet.

3.- COMMISSIONING AND OPERATION

3.3.- CORROSION RESISTANCE OF COPPER AND STAINLESS STEEL OF PLATES EXCHANGER (WATER EXCHANGER)

GUIDE TO MEASURE A ANALYSIS OF THE WATER IN THE CIRCUIT.

The resistance guide below is an attempt of give a picture of the corrosion resistance of the stainless steel of the type AISI 316 and pure copper in the water, to a number of important chemical factors. The actual corrosion is however a very complex process influenced by many factors in combination. This table is therefore a considerable simplification and should not be overvalued.

Explanations:

- + Good resistance under normal conditions
- 0 Corrosion problems can occur especially when the factors are valued as 0
- Use is not recommended

WATER CONTAINING	CONCENTRATION mg/l or ppm	AISI 316	COPPER
Alcanity (HCNO ₃)	<70	+	0
	70-300	+	+
	>300	+	0
Sulfate (SO ₄ ²⁻)	<70	+	+
	70-300	+	-
	>300	0	-
HCO ₃ / SO ₄ ²⁻	>1.0	+	+
	<1.0	+	-
Electrical conductivity	<10 μS/cm	+	0
	10-500 μS/cm	+	+
	>500 μS/cm	+	0
pH	<6.0	0	0
	6.0-7.5	0/+	0
	7.5-9.0	+	+
	>9.0	+	0
Ammonium (NH ₃)	<2	+	+
	2-20	+	0
	>20	+	-
Chloroides (Cl ⁻)	<50	+	+
	>50	0	0
Free chlorine (Cl ₂)	<1	+	+
	1-5	+	0
	>5	0/+	-
Hydrogen sulfide (H ₂ S)	<0.05	+	+
	>0.05	+	-
Free (aggressive) Carbon Dioxide (CO ₂)	<5	+	+
	5-20	+	0
	>20	+	-
Total hardness (°dH)	4.0-8.5	+	+
Nitrate (NO ₃)	<100	+	+
	>100	+	0
Iron (Fe)	<0.2	+	+
	>0.2	+	0
Aluminum (Al)	<0.2	+	+
	>0.2	+	0
Manganese (Mn)	<0.1	+	+
	>0.1	+	0

4.- MAINTENANCE

4.1.- PREVENTIVE MAINTENANCE



PREVENTIVE MAINTENANCE PREVENTS COSTLY REPAIRS.

We recommend regular and thorough servicing of the LENNOX unit. It is therefore advisable to ask your dealer about maintenance contracts. Check maintenance of the following points (depending on the operating conditions maintenance every 6 months may be necessary).

Local legislation always takes precedence.

- GENERAL STATE OF THE CASING:

Casing, paint, deterioration due to bumps, rust spots, leveling and supporting, state of the antivibration mounts, if installed, screwed panels, etc.

- ELECTRICAL CONNECTIONS:

State of cables, tightness of screws, grounding, current draw of the compressor and fans and checking that the unit is receiving the correct voltage.

- COOLING CIRCUIT:

Check that pressure values are correct and that there are no leaks. Check that there is no damage to the pipe insulation, that the state of the batteries is correct and that there are no chips or clogs retained by the air flow, etc.

- COMPRESSOR:

Inspect the oil level, if sight glass is present.
Inspect the state of the compressor mountings.

- FANS:

Check that fans turn freely and in the correct direction without excessive noises.

- CONTROL:

Check Set Points and normal operation.

- WATER:

If the installation contains anti-freeze, regularly check the state of the anti-freeze as well as the cleanliness of the water.

- WATER FILTER:

Clean the water inlet filter if necessary.

- WATER PUMP:

When the installation is going to work with percentages of glycol up to 20% and water temperatures below -5°C, even do we use a specific closing for the water pump, it is advisable to clean the water pump's closing every year and a half, in order to avoid leaks by crystallization.

- PLATE EXCHANGER:

Prove the general isolation state and tightness of the water connections.

- CHECK FOR REFRIGERANT LEAKAGE AND WATER LEAKAGE.

4.- MAINTENANCE

4.2.- CORRECTIVE MAINTENANCE



IMPORTANT

MAKE SURE THAT THE UNIT IS COMPLETELY DISCONNECTED FROM THE POWER SUPPLY WHEN CARRYING OUT ANY TYPE OF WORK ON THE MACHINE

If some component in the cooling circuit must be replaced, follow these recommendations:

- Always use original replacement parts.
- Remove the entire refrigerant charge from the unit from through the Schrader valves. Create a slight vacuum as a safety measure.
- Regulation prohibits the release on the refrigerant into the atmosphere.
- If cuts must be made in the pipe work, use pipe cutters. Do not use saws or any other tools that produce filings.
- All brazing must be carried out in a nitrogen atmosphere to prevent corrosion from forming.
- Use silver alloy brazing rod.
- Take special care that the flame from the torch is aimed in the opposite direction from the component to be welded and is covered with a wet rag in order to avoid overheating.

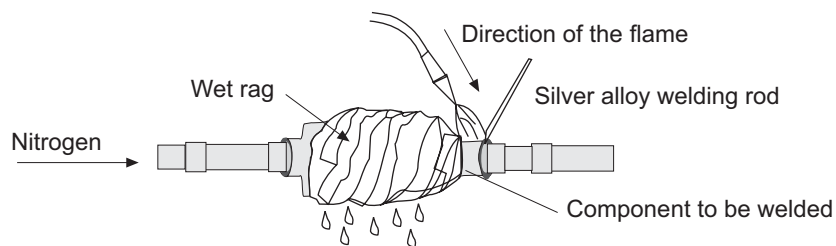

- Take very special care if 4-way check valves are to be replaced since these have internal components that are very heat-sensitive such as plastic, teflon, etc.
- If a compressor must be replaced, disconnect it electrically and un-braze the suction and discharge lines. Remove the securing screws and replace the old compressor with the new one. Check that the new compressor has the correct oil charge, screw it to the base and connect the lines and electrical connections.
- Carry out the vacuum above and below through the Schrader valves of the outdoor unit until -750 mm Hg is reached. Once this level of vacuum has been reached, keep the pump in operation for at least one hour. **DO NOT USE THE COMPRESSOR AS A VACUUM PUMP.** If the compressor runs in vacuum it will fail.
- Charge the unit with refrigerant according to the data on the Rating Plate for the unit and **check that there are no leaks.**



PRECAUTIONS TO BE TAKEN IN THE USE OF R-407C Refrigerant

If R-407C Refrigerant is used in the unit, the following precautions characteristic of this gas should be taken:

- The Vacuum Pump must have a Check Valve or Solenoid Valve.
- Pressure Gauges and Hoses for the exclusive use with R-407C Refrigerant should be used.
- The charge should be carried out in the Liquid Phase.
- Always use scales to weight-in charge
- Use the Leak Detector exclusive for R-407C Refrigerant.
- Do not use mineral oil, only synthetic oil to ream, expand or make connections.
- Keep pipes capped before using them and be very thorough about any possible moisture and dirt (dust, filings, burrs, etc.).
- When there is a leak, gather what is left of the charge, create a vacuum in the unit and completely recharge with new R-407C Refrigerant.
- Brazing should always be carried out in a nitrogen atmosphere.
- Reamers should always be well sharpened.
- The refrigerant bottle must contain at least 10 % of the total amount .

4.- MAINTENANCE

4.3.- FAILURE DIAGNOSIS

PROBLEM	CAUSE	ACTION
The unit does not start after the last start.	<ul style="list-style-type: none"> * Disconnected supply. * Main switch set to STOP. * No water flow. * Fuses are broken. * Low electrical supply. * One of the safety devices has been activated. * Compressor fault. * Low water temperature. 	<ul style="list-style-type: none"> * Check electrical supply. * Connect main switch. * Start water pump (and check air in system). * Check voltage. * Check antifreeze thermostat. * Check high/low pressure switch. * Change compressor. * Create demand for cooling.
The fan does not work (although the compressor is operating).	<ul style="list-style-type: none"> * Internal safety device open. * Bad connection. * Poor condensation control. 	<ul style="list-style-type: none"> * Let the motor cool. * Connect properly. * Check operation.
The compressor stops when the high pressure switch is cut off.	<ul style="list-style-type: none"> * Condenser coil blocked. * Unit operating outside of limiting. * Abnormal operation of the fans. 	<ul style="list-style-type: none"> * Maintain condenser coil. * Check the ventilators.
The compressor stops when the low pressure switch is cut off.	<ul style="list-style-type: none"> * Insufficient charge. * The water exchanger is blocked (water side). * No water flow. 	<ul style="list-style-type: none"> * Check the charge. * Maintain the exchanger. * Check that there is sufficient water flow.
The oil level in the compressor is very low.	<ul style="list-style-type: none"> * The crank case heater is not working. 	<ul style="list-style-type: none"> * Replace the crank case heater and check oil level.
High noise level of compressor and high and low pressures are abnormal.	<ul style="list-style-type: none"> * Phase connection for compressor power supply incorrectly. 	<ul style="list-style-type: none"> * Switch the wires between two of the phases of compressor power supply.

GREAT BRITAIN,
IRELAND:

LENNOX INDUSTRIES LTD
tél. : + 44 1604 59 9400
fax : + 44 1604 594200
e-mail : marketing @ lennoxind.com

BELGIUM :

LENNOX BENELUX N.V./S.A.
tél. : + 32 3 633 30 45
fax : + 32 3 633 00 89
e-mail : info @ lennoxbenelux.com

CZECH REPUBLIC :

JANKA LENNOX
tél. : + 420 2 510 88 111
fax : + 420 2 579 10 393
e-mail : janka @ janka.cz

FRANCE :

LENNOX FRANCE
tél. : + 33 4 72 23 20 20
fax : + 33 4 78 20 07 76
e-mail : accueil @ lennoxfrance.com

GERMANY:

LENNOX DEUTSCHLAND GmbH
tél. : + 49 69 42 0979 0
fax : + 49 69 42 0979 40
e-mail : info @ lennoxdeutschland.com

NETHERLANDS :

LENNOX BENELUX B.V.
tél. : + 31 33 2471 800
fax : + 31 33 2459 220
e-mail : info @ lennoxbenelux.com

POLAND :

LENNOX POLSKA SP z o.o.
tél. : + 48 22 832 26 61
fax : + 48 22 832 26 62
e-mail : lennoxpolska @ inetia.pl

PORTUGAL :

LENNOX CLIMATIZAÇÃO LDA.
tél. : + 351 22 993 33 70
fax : + 351 22 998 33 79
e-mail : marketing @ lennoxportugal.com

RUSSIA :

LENNOX DISTRIBUTION MOSCOW
tél. : + 7 095 246 07 46
fax : + 7 502 933 29 55
e-mail : lennox.dist.moscow @ co.ru

SLOVAKIA :

LENNOX SLOVAKIA
tél. : + 421 7 44 88 92 16
fax : + 421 7 44 88 16 88

SPAIN:

LENNOX REFAC S.A.
tél. : + 34 902 400 405
fax : + 34 91 542 84 04
e-mail : marketing @ lennox-refac.com

UKRAINE :

LENNOX DISTRIBUTION KIEV
tél. : + 380 44 213 14 21
fax : + 380 44 213 14 21
e-mail : jankauk @ uct.kiev.ua

OTHER EUROPEAN COUNTRIES,
AFRICA,
MIDDLE-EAST :

LENNOX DISTRIBUTION
tél. : + 33 4 72 23 20 14
fax : + 33 4 72 23 20 28
e-mail : marketing @ lennoxdist.com



LENNOX[®]

WWW.LENNOXEUROPE.COM