

# MDV

СДЕЛАНО ДЛЯ РОССИИ



**Technical &  
Service manual**

*Portable air conditioner*

MPN1-09ERN1

MPN1-12ERN1

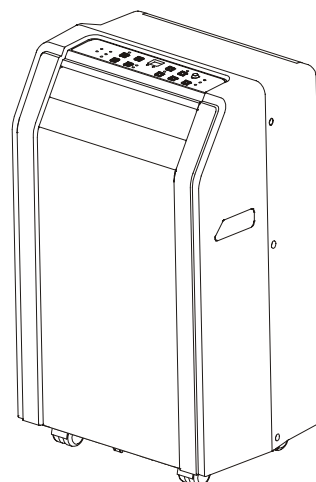

[www.mdv-russia.ru](http://www.mdv-russia.ru)

---

# CONTENT

<b>1</b>	<b>Safety precaution</b> .....	<b>1</b>
1.1	<i>Installation</i> .....	1
1.2	<i>Caution</i> .....	1
1.3	<i>Operational</i> .....	1
<b>2</b>	<b>Out dimension</b> .....	<b>3</b>
<b>3</b>	<b>Display</b> .....	<b>5</b>
3.1	<i>LED display</i> .....	
3.2	<i>LCD display</i> .....	
<b>4</b>	<b>Refrigerant cycle diagram</b> .....	<b>6</b>
<b>5</b>	<b>PCB drawing &amp; wiring diagram</b> .....	<b>7</b>
5.1	<i>9K Model</i> .....	7
5.2	<i>12K Model</i> .....	
<b>6</b>	<b>Installation detail</b> .....	<b>8</b>
6.1	<i>Position requirement for installation</i> .....	8
6.2	<i>Preparation work</i> .....	8
6.3	<i>Installation in a double-hung sash windows</i> .....	9
6.4	<i>Installation in a sliding sash windows</i> .....	10
<b>7</b>	<b>Features</b> .....	<b>12</b>
<b>8</b>	<b>Basic test procedure</b> .....	<b>13</b>
8.1	<i>Defective compressor</i> .....	13
8.2	<i>Sealed refrigeration system repairs</i> .....	14
8.3	<i>Fan motor</i> .....	16
8.4	<i>Capacitor</i> .....	17
<b>9</b>	<b>Characteristic of temperature sensor</b> .....	<b>18</b>
<b>10</b>	<b>Trouble shooting</b> .....	<b>19</b>

---

## **1 Safety precaution**

### **1.1 Installation**

For electrical work, contact the dealer, seller, a qualified electrician, or an Authorized service center.

Do not disassemble or repair the product by yourself.

Sharp edges could cause injury, be especially careful of the case edges and the fins on the condenser and evaporator.

Be sure the installation area does not deteriorate with age.

Take care to ensure that power cable could not be pulled out or damaged during operation.

Do not place anything on the power cable.

Do not plug or unplug the power supply plug during operation.

Do not store or use flammable gas or combustible near the product.

When flammable gas leaks, turn off the gas and open a window for ventilation before turn the product on.

If strange sounds, or small or smoke comes from product. Turn the breaker off or disconnect the power supply cable as soon as possible.

When the product is soaked (flooded or submerged), contact an Authorized service center.

Be caution that water could not enter the product.

Turn the main power off when cleaning or maintaining the product.

When the product is not be used for a long time, disconnect the power supply plug or turn off the breaker.

### **1.2 Caution**

Always check for gas (refrigerant) leakage after installation or repair of product.

Install the drain hose to ensure that water is drained away properly.

Keep level even when installing the product.

Do not install the product where the noise or hot air from the outdoor unit could damage the neighborhoods.

Use two or more people to lift and transport the product.

Do not install the product where it will be exposed to sea wind (salt spray) directly.

### **1.3 Operational**

Do not expose the skin directly to cool air for long periods of time. (Do not sit in the draft).

Do not use the product for special purposes, such as preserving foods, works of art, etc. It is a consumer air conditioner, not a precision refrigerant system.

Do not block the inlet or outlet of air flow.

Use a soft cloth to clean. Do not use harsh detergents, solvents, etc.

Do not touch the metal parts of the product when removing the air filter. They are very sharp.

Do not step on or put anything on the product. (Outdoor units)

Always insert the filter securely. Clean the filter every two weeks or more often if necessary.

## ***Safety Precaution***

---

Do not insert hands or other object through air inlet or outlet while the product is operated.

Do not drink the water drained from the product.

Use a firm stool or ladder when cleaning or maintaining the product.

Replace the all batteries in the remote control with new ones of the same type. Do not mix old and new batteries or different types of batteries.

Do not recharge or disassemble the batteries. Do not dispose of batteries in a fire.

If the liquid from the batteries gets onto your skin or clothes, wash it well with clean water.

Do not use the remote of the batteries have leaked.

2 Out dimension

Model: MPN1-09ERN1

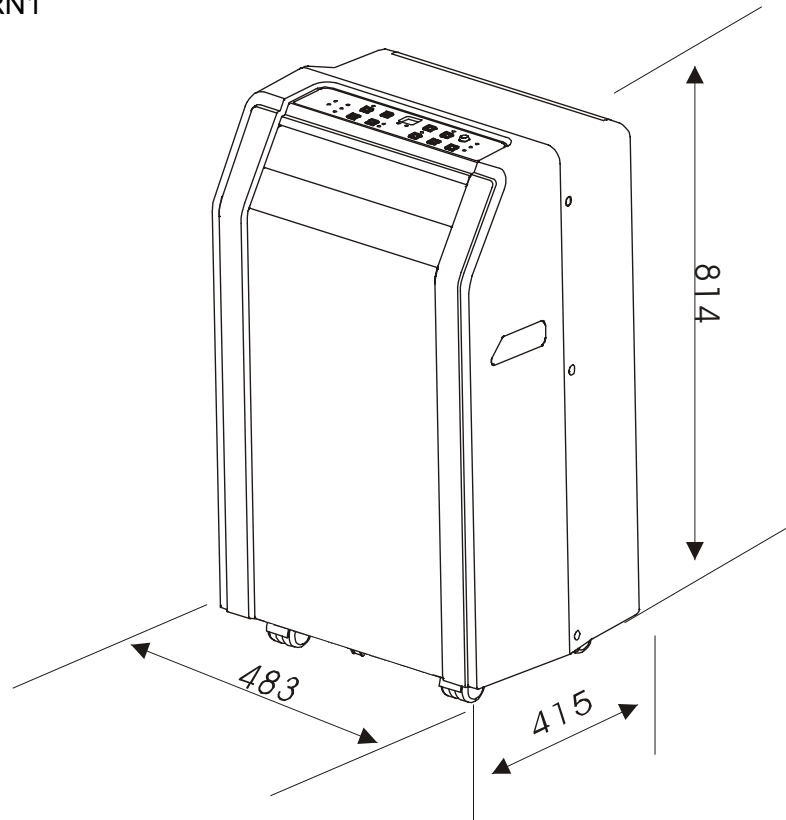

Model: MPN1-12ERN1

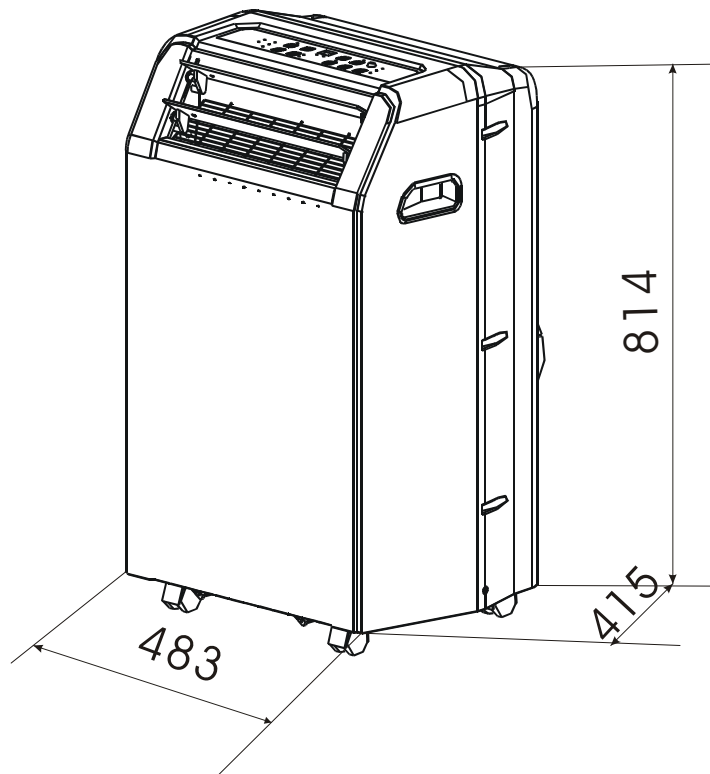

### 3 Display

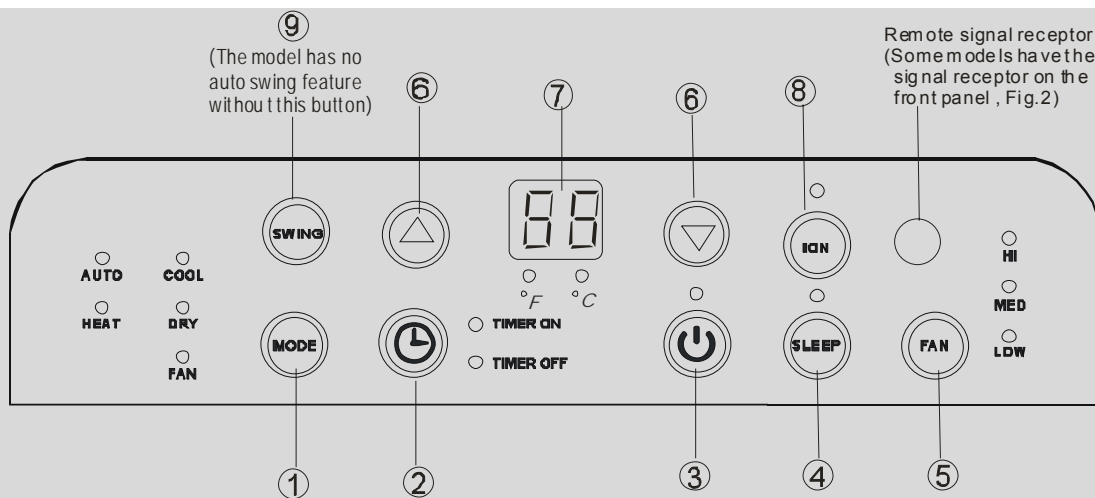

Fig.4

- 1** *MODE select button*  
 Selects the appropriate operating mode. Each time you press the button, a mode is selected in a sequence that goes from AUTO, COOL, DRY, FAN and HEAT (cooling only models without). The mode indicator light illuminates under the different mode settings Fig.4.
- 2** *TIMER button*  
 Used to initiate the AUTO ON start time and AUTO OFF stop time program, in conjunction with the  $\Delta$  &  $\nabla$  buttons.
- 3** *POWER button*  
 Power switch on/off.
- 4** *SLEEP button*  
 Used to initiate the SLEEP operation.
- 5** *FAN button*  
 Control the fan speed. Press to select the fan speed in three steps-LOW, MED, and HI. The fan speed indicator light illuminates under different fan settings.

- 6** *UP( $\Delta$ ) and DOWN( $\nabla$ ) button*  
 Used to adjust (increasing/decreasing) temperature settings (1°C/2°F increments) in a range of 17°C (62°F) to 30°C (88°F) or the TIMER setting in a range of 0~24hrs..  
**NOTE:** The control is capable of displaying temperature in degrees Fahrenheit or degrees Celsius. To convert from one to the other, press and hold the Up and Down buttons at the same time, for 3 seconds.
- 7** *LED Display*  
 Shows the set temperature in "°C" or "°F" and the Auto-timer settings. While on DRY and FAN modes, it shows the room temperature.  
**Error codes:**  
**E1-** Room temperature sensor error- Unplug the unit and plug it back in. If error repeats, call for service.  
**E2-** Evaporator temperature sensor error- Unplug the unit and plug it back in. If error repeats, call for service.  
**P1-** Bottom tray is full - Connect the drain hose and drain the collected water away. If error repeats, call for service.

## 4 Refrigerant cycle diagram

The figure below is a brief description of the important components and their function in what is called the refrigeration system

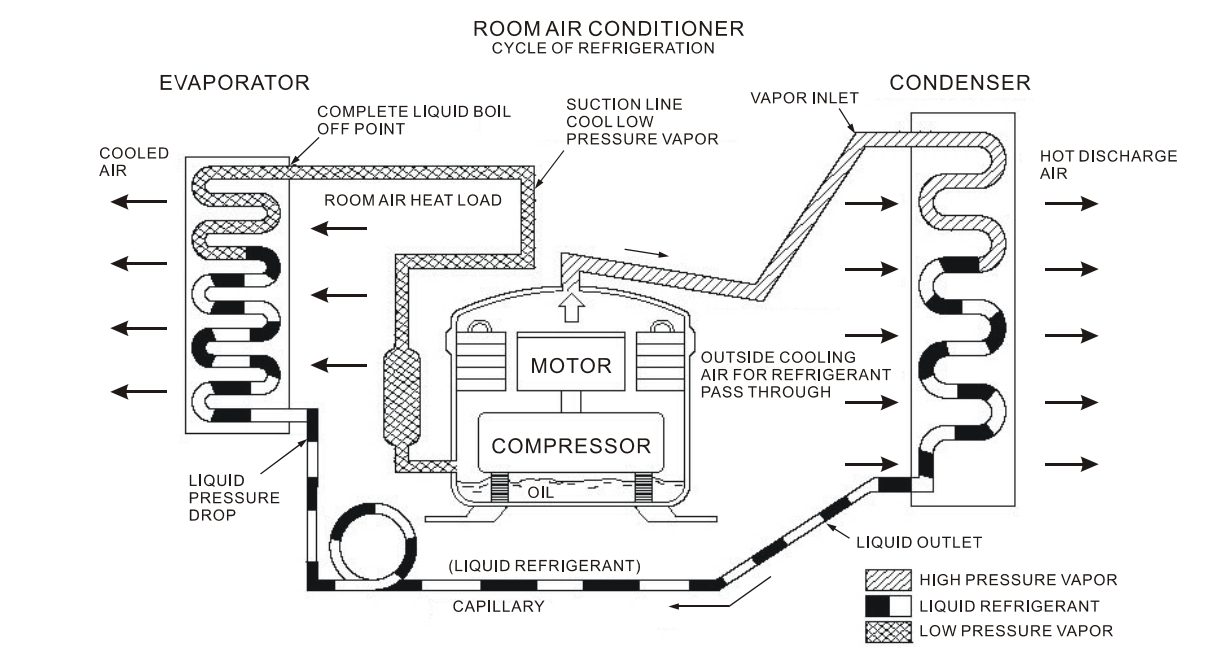



5 PCB drawing & wiring diagram

5.1 9K12K Model

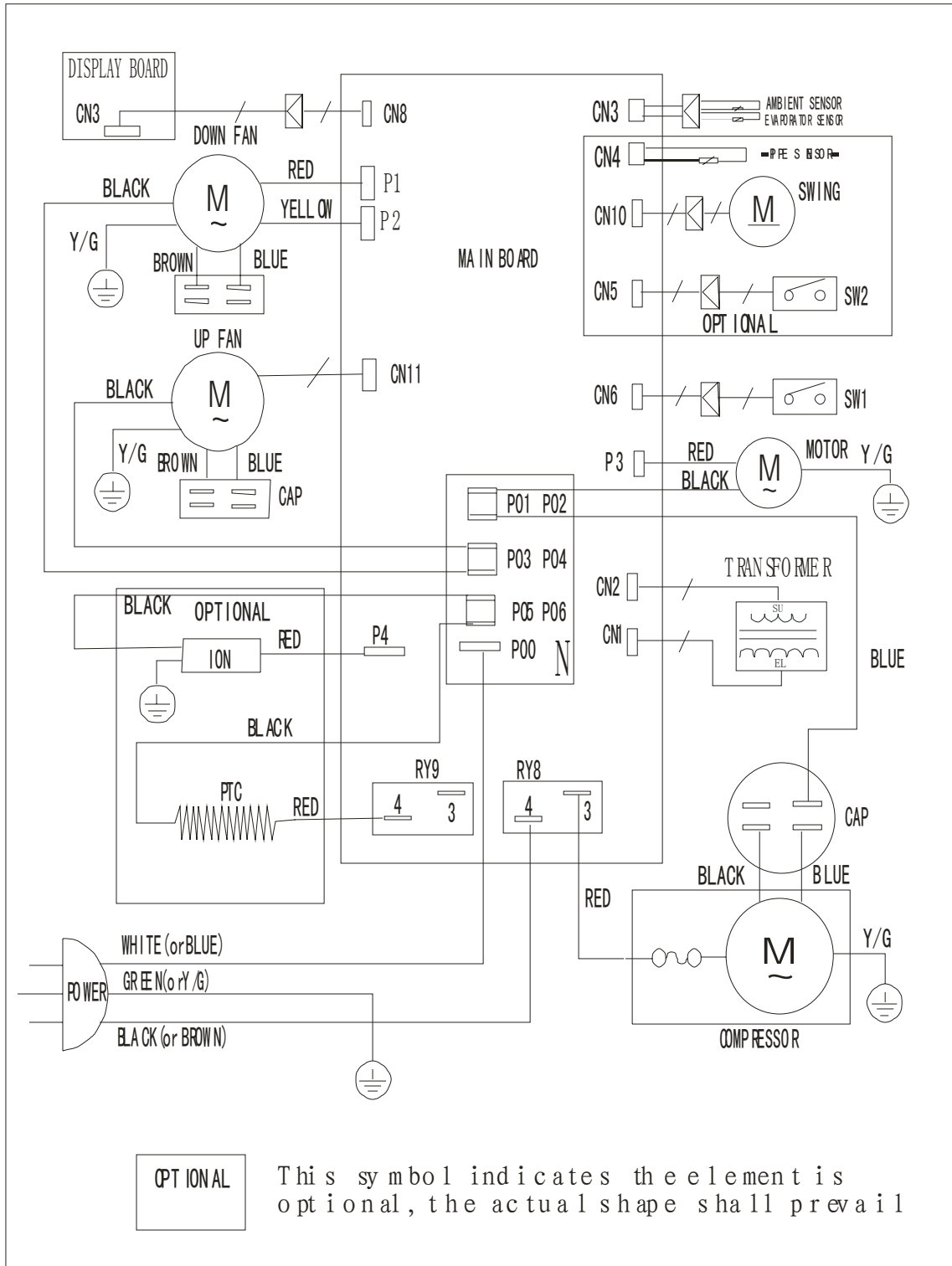

## 6 Installation detail

### 6.1 Position requirement for installation

Installation must be in a flat and spacious location where the air outlets will not be covered up. A minimum clearance of 30cm from a wall or other obstacles should be kept. The appliance shall not be used in the washroom. The plug shall accessible after appliance is positioned. Wiring shall be done according to National rules. Please see the picture show as below.

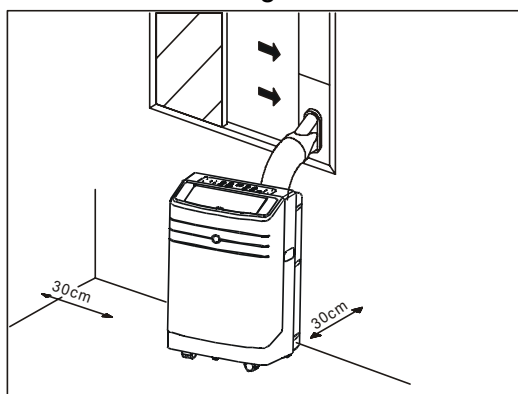

### 6.2 Preparation work

First of all, prepare the exhaust hose as the below picture show to you.

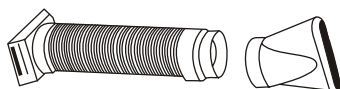

Second, connect the exhaust hose with unit, like the blow picture.

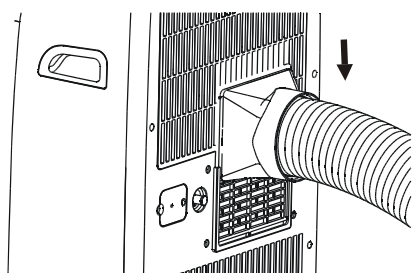

After this two steps, please make sure the exhaust hose's connect is OK.

### 6.3 Installation in a double-hung sash windows

- 6.3.1 Cut the foam seal (adhesive type) to the proper length and attach it to the window stool.

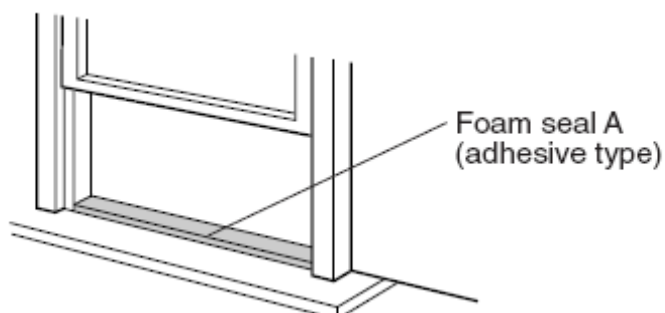

- 6.3.2 Attach the window panel to the window stool.  
Adjust the length of the window panel according to the width of window, short the adjustable panel if the width of window is less than 26".  
Open the window sash and place the window panel on the window stool.  
Secure the window panel to the window stool with 2 screws.

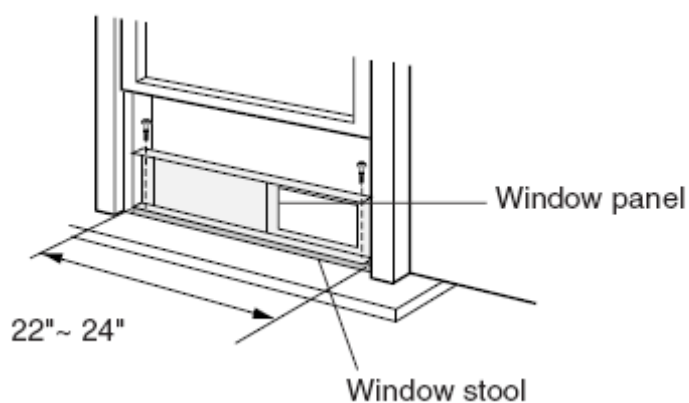

- 6.3.3 Cut the foam seal (adhesive type) to the proper length attach it on the top of window.  
Show as below picture.

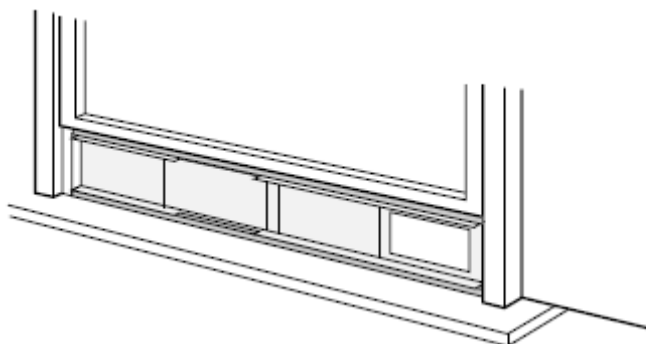

- 6.3.4 Close the window sash securely against the window.  
6.3.5 Cut the foam seal to an appropriate length and sealing the open gap between the top window sash and outer window sash. Show as below picture.

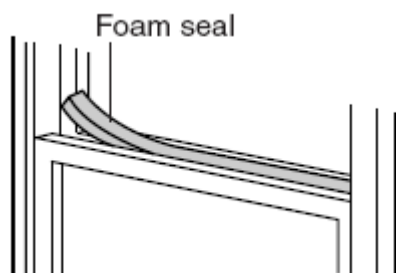

## 6.4 Installation in a sliding sash windows

6.4.1 Cut the foam seal to a proper length and adhesive to the window frame.

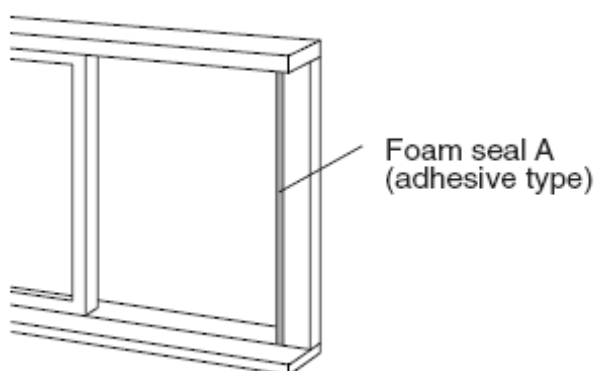

6.4.2 Attach the window panel to the window stool.

Adjust the length of the sliding window panel according to the width of window, short the adjustable panel if the width of window is less than 26".

Open the sliding sash and place the window panel on the window stool.

Secure the sliding window panel to the window stool with 2 screws.

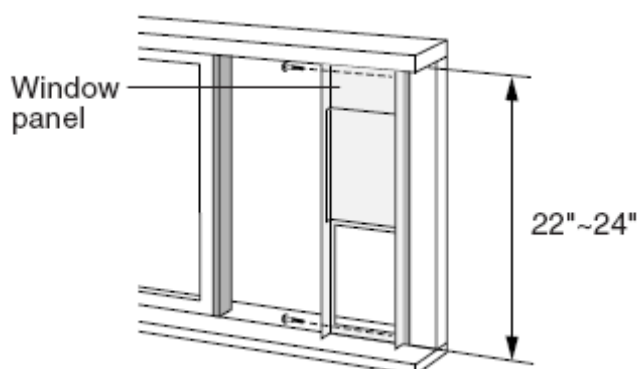

6.4.3 Cut the foam seal (adhesive type) to the proper length attach it on the top of window. Show as below picture.

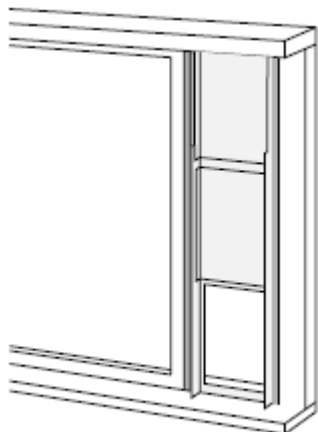

- 6.4.4 Close the sliding sash securely against the window.
- 6.4.5 Cut the foam seal to an appropriate length and sealing the open gap between the top window sash and outer window sash. Show as below picture.

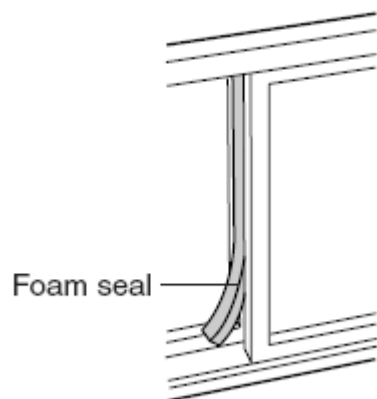

## 7 Features



Double louver  
flat appearance, Simple and  
generous  
Straight condenser , low cost,  
High-efficiency

Turbo cooling function  
Flexible air exhaust  
Advanced shower system  
Follow me function  
24 hour on/off  
Cooling  
Dry

## 8 Basic test procedure

### 8.1 Defective compressor

Compressors are single phase, 115 or 230/208 volt, depending on the model unit. All compressor motors are permanent split capacitor type using only a running capacitor across the start and run terminal.

All compressors are internally spring mounted and externally mounted on rubber isolators.

#### 8.1.1 Compressor wiring test

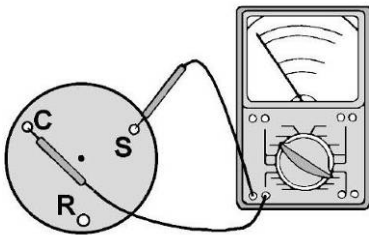

Remove compressor terminal box cover and disconnect wires from terminals. Using an ohmmeter, check continuity across the following:

- Terminal "C" and "S" - no continuity
- Open winding - replace compressor.
- Terminal "C" and "R" - no continuity
- Open winding - replace compressor.
- Terminal "R" and "S" - no continuity
- Open winding - replace compressor.

#### 8.1.2 Ground test

Use an ohmmeter set on its highest scale. Touch one lead to the compressor body (clean point of contact as a good connection is a must) and the other probe in turn to each compressor terminal (see Figure 2.) If a reading is obtained, the compressor is grounded and must be replaced.

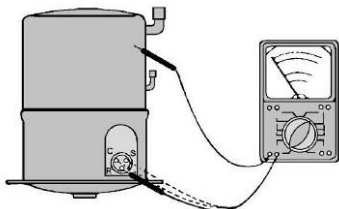

#### 8.1.3 Checking the compressor efficiency

The reason for compressor inefficiency is normally due to broken or damaged suction and/or discharge valves, reducing the ability of the compressor to pump refrigerant gas. This condition can be checked as follows:

1. Install a piercing valve on the suction and discharge or liquid process tube.
2. Attach gauges to the high and low sides of the system.

3. Start the system and run a “cooling or heating performance test.”

If test shows:

- A. Below normal high side pressure.
- B. Above normal low side pressure.
- C. Low temperature difference across coil.

The compressor valves are faulty - replace the compressor.

#### 8.1.4 Terminal overload (external)

Some compressors are equipped with an external overload which is located in the compressor terminal box adjacent to the compressor body. The overload is wired in series with the common motor terminal. The overload senses both major amperage and compressor temperature. High motor temperature or amperage heats the disc causing it to open and break the circuit to the common motor terminal.

Heat generated within the compressor shell is usually due to:

- 1. High amperage.
- 2. Low refrigerant charge.
- 3. Frequent recycling.
- 4. Dirty condenser.

#### 8.1.5 Terminal overload – Test (compressor external type)

- 1. Remove overload.
- 2. Allow time for overload to reset before attempting to test.
- 3. Apply ohmmeter probes to terminals on overload wires. There should be continuity through the overload.

#### 8.1.6 Terminal overload (internal)

Some model compressors are equipped with an internal overload. The overload is embedded in the motor windings to sense the winding temperature and/or current draw. The overload is connected in series with the common motor terminal.

Should the internal temperature and/or current draw become excessive; the contacts in the overload will open, turning off the compressor? The overload will automatically reset, but may require several hours before the heat is dissipated.

#### 8.1.7 Checking the internal overload

- 1. With no power to unit, remove the leads from the compressor terminals.
- 2. Using an ohmmeter, test continuity between terminals C-S and C-R. If not continuous, the compressor overload is open and the compressor must be replaced.

## **8.2 Sealed refrigeration system repairs**

### 8.2.1 Equipment require

- 1. Voltmeter
- 2. Ammeter
- 3. Ohmmeter



4. E.P.A. Approved Refrigerant Recovery System.
5. Vacuum Pump (capable of 200 microns or less vacuum.)
6. Acetylene Welder
7. Electronic Halogen Leak Detector (G.E. Type H-6 or equivalent.)
8. Accurate refrigerant charge measuring device such as:
  - a. Balance Scales - 1/2 oz. accuracy
  - b. Charging Board - 1/2 oz. accuracy
9. High Pressure Gauge - (0 - 400 lbs.)
10. Low Pressure Gauge - (30 - 150 lbs.)
11. Vacuum Gauge - (0 - 1000 microns)

8.2.2 Equipment must be capable of:

1. Recovery CFC's as low as 5%.
2. Evacuation from both the high side and low side of the system simultaneously.
3. Introducing refrigerant charge into high side of the system.
4. Accurately weighing the refrigerant charge actually introduced into the system.
5. Facilities for flowing nitrogen through refrigeration tubing during all brazing processes.

8.2.3 Hermetic compressor replacement.

The following procedure applies when replacing components in the sealed refrigeration circuit or repairing refrigerant leaks. (Include Compressor, condenser, evaporator, capillary tube, refrigerant leaks, etc.)

1. Recover the refrigerant from the system at the process tube located on the high side of the system by installing a line tap on the process tube. Apply gauge from process tube to EPA approved gauges from process tube to EPA approved recovery system. Recover CFCs in system to at least 5%.
2. Cut the process tube below pinch off on the suction side of the compressor.
3. Connect the line from the nitrogen tank to the suction process tube.
4. Drift dry nitrogen through the system and unsolder the more distant connection first. (Filter drier, high side process tube, etc.)
5. Replace inoperative component, and always install a new filter drier. Drift dry nitrogen through the system when making these connections.
6. Pressurize system to 30 PSIG with proper refrigerant and boost refrigerant pressure to 150 PSIG with dry nitrogen.
7. Leak test complete system with electric halogen leak detector, correcting any leaks found.
8. Reduce the system to zero gauge pressure.
9. Connect vacuum pump to high side and low side of system with deep vacuum hoses, or copper tubing. (Do not use regular hoses.)
10. Evacuate system to maximum absolute holding pressure of 200 microns or less. NOTE: This process can be speeded up by use of heat lamps, or by breaking the vacuum with refrigerant or dry nitrogen at 5,000 microns. Pressure system to 5 PSIG and leave in system a minimum of 10 minutes. Recover refrigerant, and proceed with evacuation of a pressure of 200 microns or a minimum of 10%.
11. Break vacuum by charging system from the high side with the correct amount of

refrigerant specified. This will prevent boiling the oil out of the crankcase.

NOTE: If the entire charge will not enter the high side, allow the remainder to enter the low side in small increments while operating the unit.

12. Restart unit several times after allowing pressures to stabilize. Pinch off process tubes, cut and solder the ends. Remove pinch off tool, and leak check the process tube ends.

#### 8.2.4 Special procedure in the case of compressor motor burnout.

1. Recover all refrigerant and oil from the system.
2. Remove compressor, capillary tube and filter drier from the system.
3. Flush evaporator condenser and all connecting tubing with dry nitrogen or equivalent, to remove all contamination from system. Inspect suction and discharge line for carbon deposits. Remove and clean if necessary.
4. Reassemble the system, including new drier strainer and capillary tube.
5. Proceed with processing as outlined under hermetic component replacement.

#### 8.2.5 Rotary compressor special troubleshooting and service

Basically, troubleshooting and servicing rotary compressors is the same as on the reciprocating compressor with only a few exceptions.

1. Because of the spinning motion of the rotary, the mounts are critical. If vibration is present, check the mounts carefully.
2. The electrical terminals on the rotary are in a different order than the reciprocating compressors. The terminal markings are on the cover gasket. Use your wiring diagram to insure correct connections.

#### 8.2.6 Refrigerant charge

1. The refrigerant charge is extremely critical. It must be measured charge carefully - as exact as possible to the nameplate charge.
2. The correct method for charging the rotary is to introduce liquid refrigerant into the high side of the system with the unit off. Then start compressor and enter the balance of the charge, gas only, into the low side.

The introduction of liquid into the low side, without the use of a capillary tube, will cause damage to the discharge valve of the rotary compressor.

NOTE: All inoperative compressors returned to Friedrich must have all lines properly plugged with the plugs from the replacement compressor.

### **8.3 Fan motor**

A single phase permanent split capacitor motor is used to drive the evaporator blower and condenser fan. A self-resetting overload is located inside the motor to protect against high temperature and high amperage conditions.

#### 8.3.1 Fan motor test

1. Determine that capacitor is serviceable.
2. Disconnect fan motor wires from fan speed switch or system switch.

3. Apply "live" test cord probes on black wire and common terminal of capacitor. Motor should run at high speed.
4. Apply "live" test cord probes on red wire and common terminal of capacitor. Motor should run at low speed.
5. Apply "live" test cord probes on each of the remaining wires from the speed switch or system switch to test intermediate speeds.

## 8.4 Capacitor

A run capacitor is wired across the auxiliary and main winding of a single phase permanent split capacitor motor such as the compressor and fan motor. A single capacitor can be used for each motor or a dual rated capacitor can be used for both.

The capacitor's primary function is to reduce the line current while greatly improving the torque characteristics of a motor. The capacitor also reduces the line current to the motor by improving the power factor of the load. Run capacitor hook-up line side of the capacitor is marked with a red dot and is wired to the line side of the circuit

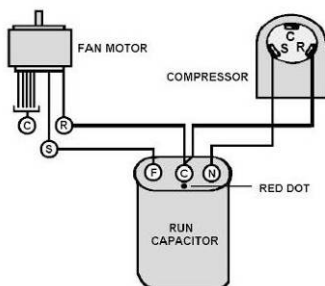

### 8.4.1 Capacitor test

1. Remove capacitor from unit.
2. Check for visual damage such as bulges, cracks, or leaks.
3. For dual rated, apply an ohmmeter lead to common (C) terminal and the other probe to the compressor (HERM) terminal. A satisfactory capacitor will cause a deflection on the pointer, and then gradually move back to infinity.
4. Reverse the leads of the probe and momentarily touch the capacitor terminals. The deflection of the pointer should be two times that of the first check if the capacitor is good.
5. Repeat steps 3 and 4 to check fan motor capacitor.

NOTE: A shorted capacitor will indicate a low resistance and the pointer will move to the "0" end of the scale and remain there as long as the probes are connected.

An open capacitor will show no movement of the pointer when placed across the terminals of the capacitor.

**9 Characteristic of temperature sensor**

Temp. °C	Resistance KΩ	Temp. °C	Resistance KΩ	Temp. °C	Resistance KΩ
-10	62.2756	17	14.6181	44	4.3874
-9	58.7079	18	13.918	45	4.2126
-8	56.3694	19	13.2631	46	4.0459
-7	52.2438	20	12.6431	47	3.8867
-6	49.3161	21	12.0561	48	3.7348
-5	46.5725	22	11.5	49	3.5896
-4	44	23	10.9731	50	3.451
-3	41.5878	24	10.4736	51	3.3185
-2	39.8239	25	10	52	3.1918
-1	37.1988	26	9.5507	53	3.0707
0	35.2024	27	9.1245	54	2.959
1	33.3269	28	8.7198	55	2.8442
2	31.5635	29	8.3357	56	2.7382
3	29.9058	30	7.9708	57	2.6368
4	28.3459	31	7.6241	58	2.5397
5	26.8778	32	7.2946	59	2.4468
6	25.4954	33	6.9814	60	2.3577
7	24.1932	34	6.6835	61	2.2725
8	22.5662	35	6.4002	62	2.1907
9	21.8094	36	6.1306	63	2.1124
10	20.7184	37	5.8736	64	2.0373
11	19.6891	38	5.6296	65	1.9653
12	18.7177	39	5.3969	66	1.8963
13	17.8005	40	5.1752	67	1.83
14	16.9341	41	4.9639	68	1.7665
15	16.1156	42	4.7625	69	1.7055
16	15.3418	43	4.5705	70	1.6469

**10 Trouble shooting**

PROBLEM	POSSIBLE CAUSE	REMEDY
No power display on panel or any one of the buttons failure.	Power failure	Check the power supplier if the power supplier is supplied to the unit. Check the power cord and correct if damaged.
	Transformer (Discharge transformer before testing)	Check resistance between the two input/output lines on transformer. Replace the transformer if either of the input/output is open or the transformer is damaged.
	Display board or main PCB failure	Check the voltage on display board. Replace the display board if it is +5V else replace the main PCB.
Remote control failure.	Battery failure	Check the voltage of battery. Replace batteries if the voltage is lower than 2.3V.
	Fan motor runs intermittently	Cycles on overload.
Test capacitor. Replace if not within +/-10% of manufacture's rating.		
Check bearings. Replace the motor if the blower wheel cannot rotate freely.		
Pay attention to any change from high speed to low speed. Replace the motor if the speed does not change.		
Compressor stops instantly after startup.	Refrigerant	The amount of the refrigerant is too much, making the compressor load too big. Recycle and recharge the refrigerant after checking for the reason.
	Compressor	The compressor is blocked inside. Replace after checking for the reason.
Fan motor will not run.	No power	Check voltage at electrical outlet. Correct if none.
	Water alarm	Check and correct if water alarm happens.
	Power supply cord	Check voltage at the power cord terminal on Main PCB. Replace the power cord if none.
	Transformer (Discharge transformer before testing)	Check resistance between the two input/output lines on transformer. Replace the transformer if either of the input/output is open or the transformer is damaged.
	Wire disconnected or connection loose	Connect wire. Refer to wiring diagram for terminal identification. Repair or replace loose terminal.
	Main PCB failure	Select fan speed and Check the voltage on main PCB. Replace the main PCB if no voltage in anyone.
	Capacitor (Discharge capacitor before testing)	Test capacitor. Replace if not within +/-10% of manufacture's rating. Replace if shorted, open or damaged.
	Will not rotate	Fan blower hitting scroll. Realign assembly. Check fan motor bearings. Replace the motor if motor shaft do not rotate.
Fan motor noise.	Fan blower	Replace the fan blower if cracked, out of balance, or partially missing.

## Trouble shooting

	Loose screws	Tighten them.
	Worn bearings	Replace the motor if knocking sounds continue when running or loose, or the motor hums or noise appears to be internal while running.
Compressor will not run while fan motor runs.	Voltage	Check voltage. Call Supply Authority if not within limits.
	Wiring	Check the wire connections, if loose, repair or replace the terminal. If wires are off, refer to wiring diagram for identification, and replace. Check wire locations. If not per wiring diagram, correct.
	Main PCB failure	Check voltage of main PCB. Replace the main PCB if open.
	Capacitor (Discharge capacitor before testing)	Check the capacitor. Replace if not within +/-10% of manufacturers rating. Replace if shorted, open, or damaged.
	Room temp sensor	Check the temperature setting if not at the coolest (in cooling mode) or the warmest (in heating mode). Set it if not.
	Compressor	Check the compressor for open circuit or ground. If open or grounded, replace the compressor.
Excessive noise.	Copper tubing	Remove the cabinet and carefully rearrange tubing not to contact cabinet, compressor, shroud and barrier.
Water full alarm	Water depth is over load in chassis(P1)	Use a drain hose and a pan to drain the condensed water in the chassis.
	Water depth sensor if failure	Check and replace if failure.
	shaded pole motor failure	Check and replace if the motor is failure.
Cooling or heating feels not good	Air filter	Clean or replace if restricted.
	Air discharge pipe	Realign and assemble if the installation of the air discharging pipe failure. Replace if damaged.
	Unit undersized	Determine if the unit is properly sized for the area to be cooled or heated.
	Condenser and Evaporator	Clean or replace if restricted.
	shaded pole motor failure	Check and replace if the motor is failure.
	Fan motor	Check the fan capacitor and replace if not within +/-10% of manufactures rating.
	Air flow	Clean or remove if any barrier is found to block the inlet/outlet wind flow of the unit.
	Less refrigerant	Check the tubes for reasons of leakage. Recycle the refrigerant, correct the leakage points and recharge.
	Capillary tube	Regulate the flow if capillary tube and make the evaporating temperature appropriate if the evaporator is frosted. Replace if blocked. Repair joint if leaking.

## Trouble shooting

	Compressor	The inlet and outlet valve of the compressor is damaged, making the low pressure connected with the high pressure. The refrigerating system can not produce high pressure and low pressure. Replace the compressor after checking for the reason.
	Heat sources	Reduce if too many.
No cooling or heating.	No power	Check the voltage. Call an electrician if no within the limit.
	Wiring	Check the terminals. Repair and correct if loose.
	Temperature setting	Check and adjust the temperature setting.
	Mode setting	Check and adjust the mode setting.
	Compressor	Check and replace if the compressor, the over-load protector or wiring is broken.
	Electric heater failure	Check and replace if the heater is damaged.
	Over heat fuse failure	Check and replace if the fuse is damaged.
	Main PCB	Check the voltage of main PCB. Replace the main PCB when the unit failure in heating mode.
The unit starts and stops frequently.	Power supply	The input power supply voltage is too low. Call an electrician if not within limits.
	Main PCB	Check and replace the main PCB if the compressor relay on PCB is shorted or damaged.
	Room temperature	When the room temperature is too high, the compressor will protect.