



# LCE

## Air condensed water chillers and heat pumps LCE series





# Index

---

- **Unit Identification**

---
- **The Series**

---
- **Constructive Features**

---
- **Models and Configurations**

---
- **Technical Characteristics**

---
- **Performance**

---
- **Calculation Factors**

---
- **Sound Level**

---
- **Operating Limits**

---
- **Pressure Drops**

---
- **Pumping Systems**

---
- **Water Circuit**

---
- **Electrical Connections**

---
- **Overall Dimensions**

---
- **Installation Clearance Requirements**

---
- **Unit Weights**

## Unit Identification

The unit data are reported on the rating label in this page.

### The label shows the following data:

- Series and size of the unit.
- Date of manufacture.
- Main technical data.
- Manufacturer.
- The label is applied on the unit, usually on the enclosing panels beside the condenser coil.

### Important: Never remove the label

- Serial number of the unit.
- The serial number permits to identify the technical characteristics and the components installed.
- Without this datum it will be impossible to identify the unit correctly.



0398

Modello - Model  
Matricola - Serial number  
Data di produzione - Date of production  
Categoria PED/ CE 97/23 Category  
Procedura di valutazione conformità - Conformity module  
Massima pressione esercizio - Max. working pressure [bar-r]  
Max. pressione esercizio lato bassa pressione (carcassa compr.) -  
Max. working pressure low pressure side (compr. shell) [bar-r]  
Max. temp. di stoccaggio - Max. storage temperature [°C]  
Max. temp. funzionamento - Max. ambient working temperature [°C]  
Min.temp.ambiente di funzionamento-Min. ambient working temp. [°C]  
Potenza frigorifera nominale - Nominal Cooling Capacity  
Potenza nominale in riscaldamento - Nominal Heating Capacity [kW]  
Refrigerante - Refrigerant [Ashrae 15/1992]  
Carica refrigerante - Refrigerant charge [kg]  
Peso a vuoto - Empty weight [kg]  
Taratura press. lato ALTA - HIGH pressure Switch Set [bar-r]  
Taratura press. lato BASSA - LOW pressure Switch Set [bar-r]  
Taratura valvola sicurezza refrigerante -  
Safety valve refrigerant Set [bar-r]  
Taratura valvola sicurezza acqua -  
Safety valve water side Set [bar-r]  
Alimentazione - Power supply [V/Ph/Hz]  
Potenza assorbita Nominale - Nominal power input [kW]  
Corrente nominale - Nominal absorbed current [A]  
Corrente massima - Full load ampere FLA [A]  
Corrente di spunto - Starting Current LRA [A]  
Schema elettrico - Wiring diagram  
Schema frigorifero - Refrigeration diagram



## The Series

The use of R410A as a refrigerant in specifically developed chillers brings guaranteed advantages thanks to the high exchange coefficients and lower pressure drops in the heat exchanger, which mean enhanced efficiency and reliability plus energy savings.

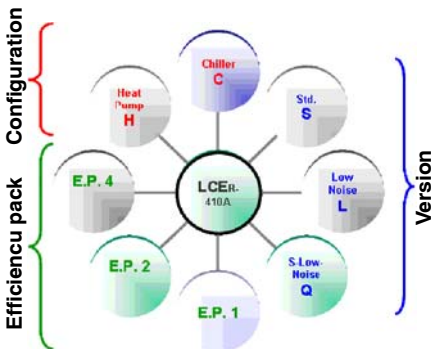

The LCE project has enabled a range to be developed which, starting off from 17 basic sizes, generates no fewer than 150 different cooling-only or heat pump models - given all the configurations and options that multiply the possibilities of choice - with powers from 40 to approximately 320 kW.

A vast array of options and accessories allows you to build "dedicated" solutions tailored to numerous design and installation requirements.

### Configuration

- C** Chiller cooling only.
- H** Reversible heat pump.

### Efficiency pack

The possibility of setting up different cooling circuits in units of the same power means being able to personalise efficiency levels under full or part load conditions.

- 1 Dual circuit / dual compressor. The dual circuit-dual compressor models provide high efficiency values under full load (EER and COP).
- 2 Single circuit / dual compressor. The solution of using two compressors in a single cooling circuit increases efficiency under part load conditions, reaching ESEER values greater than 4.

- 3 Dual circuit / 4 compressors. 4 compressors enable the unit to output power in 4 steps and adapt perfectly to the actual thermal load of the system, while reducing starting currents.

### Version

- S** Standard version.
- L** Low-Noise version for a low noise impact.
- Q** Quiet version for a super low noise impact.

### Electronic expansion valves

All units, irrespective of type of construction, are equipped with electronic expansion valves to maximise efficiency under part load conditions.

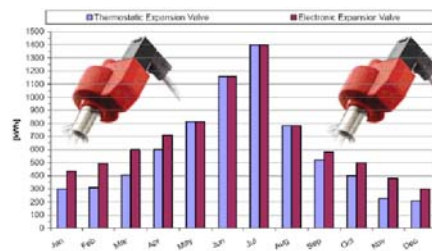

Electronic expansion valves have the capacity, if correctly parameterised and controlled by the software, to optimise cooling circuit performance and decrease the system's power consumption.

When a sudden change occurs in the thermal load, with a traditional expansion valve there is a transient time of 2 to 3 minutes before a condition of equilibrium is reached.

Proactive action of an Electronic Expansion Valve.

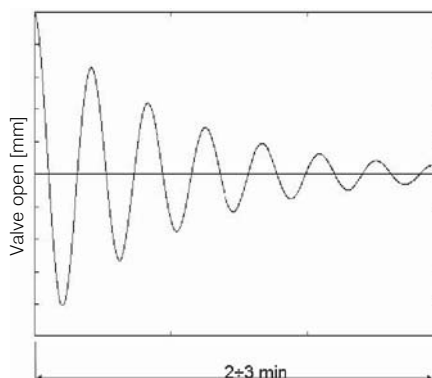

In the event of a compressor on/off request:

The electronic driver pre-positions the valve at a point very near the final equilibrium point.

- A status of equilibrium is quickly reached with small adjustments;
- The electronic expansion valve becomes an active, rather than passive, component within the system;
- The transient time is greatly reduced;
- Overall the system is more efficient, with higher EERs and therefore greater savings.

### Regulation

The electronic control system allows the setpoint to be adjusted automatically according to the outdoor temperature (sensor available as an optional) in order to reduce consumption and broaden the working temperature range.

In the summer mode, compensation begins with an outdoor air temperature of 30°C.

The diagram below indicates the increases in efficiency at different water temperatures.

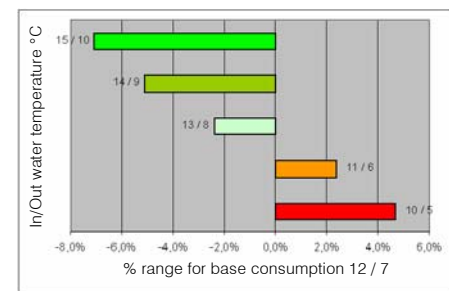

### Self-adaptive

The unit can also function in systems with a low water content, even without the use of a water buffer tank, thanks to the automatic adjustment which limits the number of compressor starts and thus extends the life of the compressors themselves.

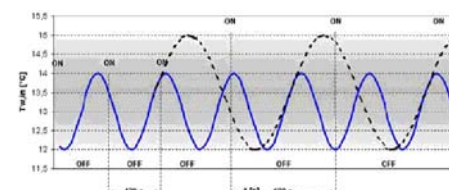

## Smart defrost system

The exclusive defrost system (optional feature available with the advanced controller) can correctly identify an impairment of performance in the outdoor exchanger due to the formation of ice and minimise the process time in relation to normal operation of the unit.

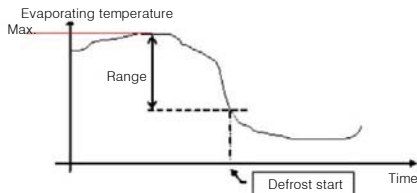

## Interconnectivity

ERGO network s as a standard feature with advanced microprocessor control it is possible to implement:

- LAN networks
- GSM kit for reading and setting data via a mobile phone
- WEB kit for reading and setting data remotely from a PC via access to the IP address of the chiller unit or network of units.

## Water pump options

Complete hydronic kits can be incorporated within the units without modifying their size and you have the option of choosing the water circulation pump.

- Single pump, standard head or uprated (high head).
- Dual pump solution (OR): standard head or uprated (high head), operating singly. The pumps operate in turns on a time/fault basis. In the case, the microprocessor controls the pumps in such a way as to equally divide the hours of operation, changing over the pumps in the event of a fault.
- Dual pump solution (AND): standard or uprated pump, operating simultaneously. Connected in parallel, they deliver water at the nominal flow rate when operating simultaneously.

"OR" solution

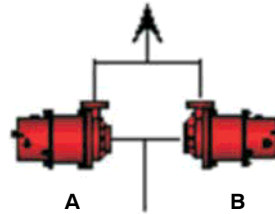

"AND" solution

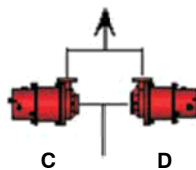

$$C + D = A = B$$

Under part load conditions operation is limited to a single pump, reducing the capacity by 1/3 compared to the rated value and resulting in average savings of about 30% in pumping costs.

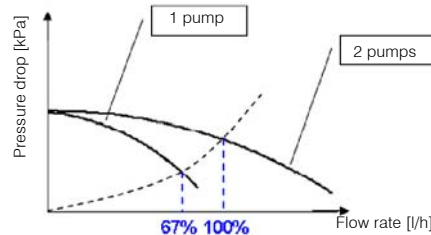

In the case of two pumps in combination, the advanced microprocessor is mandatory because it controls the on/off switching of the second pump according to the number of capacity steps required at every instant. This makes operation of the unit cost-effective for most of its life since, based on well-known analyses, chillers operate 97% of the time under part load conditions.

All LCE models are constructed so that the water inlet and outlet pipes are outside the unit. Pairs of quick connect couplings with a welding ring are available as an optional.

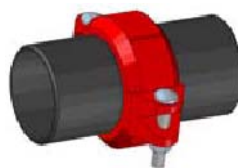

## Reduction in overall dimensions / transport costs

Reduction in footprint and increase in power density (kW/m<sup>2</sup>). Thanks to the decrease in depth (now 1180 mm up to model 160), it is possible to reduce transport costs.



## Costructive Features

### Structure

Galvanised steel sheet base with a textured polyester powder coating for outdoors (colour RAL9005, deep black). Structure built from steel sheet, with a textured polyester powder coating for outdoors (colour RAL9002) to ensure effective resistance to corrosive agents. Fastening devices are made of non-oxidizable materials, or carbon steel that has undergone surface-passivating treatments.

The compressor compartment is completely sealed and may be accessed on 3 sides thanks to easy-to-remove panels that greatly simplify maintenance and/or inspection.

Micro-switch coupled with the rear panel over the ventilating section to make routine and extraordinary maintenance operations safe.

Insulation from vibrations can be achieved using rubber or spring vibration dampers (available as an optional).

### Hydronic kits

All units have lead-out plumbing connections with victaulic connectors (selectable option) situated on the rear of the unit, suitably positioned air vent valves, safety valve and paddle flow switch and outlet water temperature probe functioning as an antifreeze thermostat.

Available on request there are numerous pump systems that can be incorporated within the chiller unit without changing its overall dimensions:

- single standard or high delivery head pump
- standard or high head pump and associated back-up pump
- standard pump for combined operation.
- high head pump for combined operation.

Each hydronic kit includes a membrane expansion tank.

The pump system is incorporated in the structure of the unit and is arranged so as to ensure that the pump motors are always cooled by outside air.

In the case of pump systems including a back-up pump, the microprocessor

controls the pumps in such a way as to equally divide the hours of operation, changing over the pumps in the event of a fault. In the case of two pumps in combination, the advanced microprocessor is mandatory because it controls the on/off switching of the second pump according to the number of capacity steps required.

The pump system is incorporated in the structure of the unit and is arranged so as to ensure that the pump motors are always cooled by outside air.

In addition to the pump kit, a water buffer tank can be installed inside the fan compartment, on the outlet side of water circuit, in order to attenuate the inevitable temperature fluctuations caused by the ON/OFF switching of the compressors.

The available optionals include a water circuit antifreeze kit, which can be configured according to the hydronic solutions chosen, and uses selfregulating PTC heating elements interlocked with compressor operation and the set-point value.

### Cooling circuit

The cooling circuit is built using only components of the finest quality brands produced by qualified manufacturers according to the specifications of Directive 97/23 for brazing. Strict design and quality control standards are applied during all phases of construction of the internal piping.

For all rated powers, the cooling circuit can be set up in 3 different configurations called "efficiency packs":

- Efficiency pack 1: 2 cooling circuits, 1 compressor per circuit.
- Efficiency Pack 2: 1 cooling circuit, 2 compressors in tandem.
- Efficiency Pack 4: 2 cooling circuits, 2 compressors per circuit.

The main components of the cooling circuit are:

- Scroll-type compressors designed to work with R410A, operating singly or combined in a tandem configuration.
- Brazed plate heat exchangers made of STAINLESS STEEL AISI 316 and optimised for use with R410A.

- Finned block condenser with 8 mm copper piping and aluminium fins, characterised by ample heat exchange surfaces.
- Dehydrating filter.
- Flow indicator with humidity indicator.
- Electronically controlled electric expansion valve including software designed and optimised so as to follow the cooling load under all conditions of use. In the case of heat pump models, dual mechanical thermostatic valve dedicated to each finned coil to provide optimised operation in the heating mode (the electronic valve is used in the cooling mode).
- Cycle-reversing valve (heat pumps).
- Check valves (heat pumps).
- Liquid receiver (heat pumps).
- High and low pressure switches.
- Safety valve.
- Schrader valves for checks and/or maintenance.
- Refrigerant pressure gauges (optional)

Optionally, partial recovery of the condensation heat (40%) can be obtained by means of suitably sized plate exchangers.

### Fan drive assembly

4/6/8-pole axial-type fans with airfoil-shaped blades made of hybrid plastic/aluminium material, statically and dynamically balanced in two planes, fitted with a protective grille and mounted with rubber vibration dampers placed in between. The fan is housed in a special compartment having a profile designed to optimise ventilation.

The condensation control system continuously and automatically regulates the fan speed, further limiting the noise emissions of the unit during nighttime operation and under partial load conditions (opt).

## **Finned block heat exchanger**

Made of 8mm diameter copper pipes and aluminium fins, generously sized. The use of finned block heat exchangers with 8mm diameter pipes reduces pressure drops on the air side, thus significantly improving the noise levels of the units.

The special engineering of the heat exchangers allows defrost cycles to be carried out at maximum speed in the models with heat pump operation, which brings clear benefits in terms of the integrated efficiency of the whole cycle.

The finned block condensers can be fitted with a protective outer grille.

## **Electric control board**

Electric control board with a door interlock isolating switch and watertight panels providing quick access to the control keys, built in conformity with standard EN 60204, wired in accordance with directive EEC 73/23, directive CEE 89/336 on electromagnetic compatibility and related standards. Is equipped with an air circulation system that is active while the unit is running.

The door of the compartment housing the electric control board lifts up and open by means of hydraulic pistons, optimising accessibility during routine and extraordinary maintenance work.

The cables inside the electric compartment are numbered.

The available options include a 400/3/50 power configuration with transformer for the auxiliary circuits, or thermal magnetic motor protectors for safeguarding against overcurrents/mains voltage fluctuations, or a combination of these solutions.

## **Electronic microprocessor control**

The electronic control enables the complete control of the unit. It can be easily accessed through a polycarbonate flap with IP65 protection rating.

The self-adaptive logic enables the unit to operate even in systems where the water content is low, without the use of an inertial water storage reservoir. By reading the outdoor air temperature, it can automatically change the setpoint to adapt it to the outdoor load conditions or keep the unit running even in the harshest winter conditions. The basic controller comes complete with the MODBUS protocol and enables an immediate connection to ERGO networks.

The main functions are control of water temperature at the evaporator inlet, complete alarm management, dynamic setpoint adjustment according to air temperature, possibility of connecting an external terminal which replicates the control functions and can be connected to an RS485 serial line for supervision/remote technical support.

Available on request is an advanced PCO microprocessor + PGD graphic keypad which enables fine control of the unit and of the cooling circuit parameters, providing a sort of record of the vital parameters of the cycle (pressures and temperatures) in order to draw attention to any anomalous behaviour.

With the advanced microprocessor control it is possible to set up LAN networks for controlling 4 units in parallel. Options of remote communication via RS485 serial card (Carel or Modbus protocol), Lonworks, with GSM modem kit or PicoWeb Ethernet card.

Supervisor software supplied on request.



## Models and Configurations

### Field of application

LCE air-condensed water chillers and heat pumps have been designed to cool and heat water for air conditioning and heating systems in residential, commercial and industrial buildings. When choosing a model, after determining the required power it is necessary to select the version (CHILLER or HEAT PUMP), cooling circuit architecture (EFFICIENCY PACK) and degree of noise control (STANDARD, LOW NOISE or QUIET). It will then be necessary to choose the optionals and accessories which define the unit.

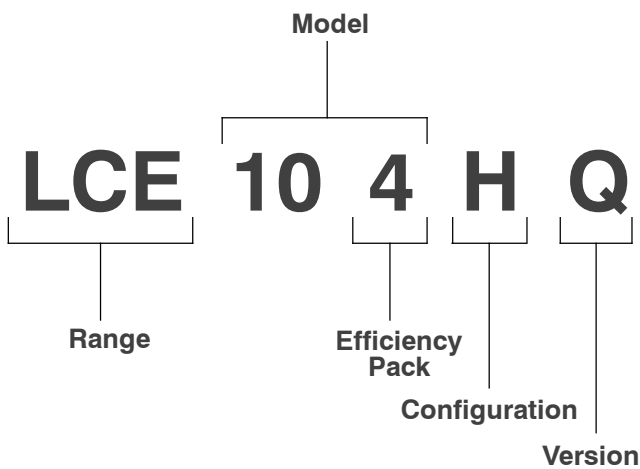

### Efficiency pack

The possibility of setting up different cooling circuits in units of the same power means being able to personalise efficiency levels under full or part load conditions.

- Dual circuit / dual compressor.  
The dual circuit-dual compressor models provide high efficiency values under full load (EER and COP).
- Single circuit / dual compressor.  
The solution of using two compressors in a single cooling circuit increases efficiency under part load conditions, reaching ESEER values greater than 4.
- Dual circuit / 4 compressors.  
4 compressors enable the unit to output power in 4 steps and adapt perfectly to the actual thermal load of the system, while reducing starting currents.

### Configuration

- C Chiller cooling only.
- H Reversible heat pump.

### Version

- S Standard version.
- L Low-Noise version for a low noise impact.
- Q Quiet version for a super low noise impact

Tab.1 - Configuration DIGIT

<b>DIGIT 1 - Power supply</b>	
0	400V / 3Ph / 50Hz + N
1	400V / 3Ph / 50Hz with 230V transformer
2	400V / 3Ph / 50Hz + N + thermal-magnetic breaker
3	400V / 3Ph / 50Hz with transformer + thermal-magnetic breaker
<b>DIGIT 2 - Microprocessor control / expansion devices</b>	
0	Base + electronic expansion valve
B	Advanced + electronic expansion valve
<b>DIGIT 3 - Water circulation pump</b>	
0	Not present
1	Single standard pump and expansion vessel
2	Single uprated pump and expansion vessel
3	Double standard pump for simultaneous (AND) operation and expansion vessel (only if digit 2 = B)
4	Double uprated pump for simultaneous (AND) operation and expansion vessel (only if digit 2 = B)
5	Double standard pump for alternate (OR) operation and expansion vessel
6	Double uprated pump for alternate (OR) operation and expansion vessel
<b>DIGIT 4 - Water tank</b>	
0	Not present
S	Present
<b>DIGIT 5 - Heat recovery (condensation control is mandatory)</b>	
0	Not present
D	Partial (desuperheater, 40%)
<b>DIGIT 6 - Condensation control</b>	
0	Not present
C	Fan speed reg. with cutting phase device (mandatory with DIGIT 5 = D)
<b>DIGIT 7 - Antifreeze kit</b>	
0	Not present
E	Present, standard unit (antifreeze kit only on plates evaporator)
P	Present, unit with pump and expansion vessel
S	Present, unit with buffer tank, pump and expansion vessel
<b>DIGIT 8 - Remote communication</b>	
0	Not present
1	RS485 (Carel o Modbus protocol)
2	Lonworks serial card (only if DIGIT 2 = B)
<b>DIGIT 9 - Special execution for finned pack heat exchanger</b>	
0	Standard
R	Copper / Copper
C	Cataphoresis
B	Fins protection treatment
<b>DIGIT 10 - Package</b>	
0	Standard
1	Wooden crate
2	Wooden box
<b>DIGIT 11 - Base insulation</b>	
0	Not present
G	Rubber antivibration dampers
M	Spring antivibration dampers
<b>DIGIT 12 - Remote control</b>	
0	Not present
1	Simplified remote control panel
2	Base microprocessor remote control panel (only if DIGIT 2 = 0)
3	Advanced microprocessor remote control panel (only if DIGIT 2 = B)
<b>DIGIT 13 - Hydraulic installation items</b>	
0	Not present
V	Pair of victaulic coupling for quick in-out water connection
<b>Accessories</b>	
A	Power factor correction capacitors
B	Soft-starter kit (**)
C	Service kit (probes for a unit operation quick check) (*)
D	Clock card (*)
E	ON-OFF compressors control
F	Remote control to limit compressor turning ON (*)
G	Boards for customizable digital alarms (*)
H	Outdoor air temperature probe for automat. adjustment of the set point (*)
I	Pressure gauges
L	Kit for filter interception (solenoid and tap on the liquid line)
M	Other reference standard than the EEC 97/23 PED
N	Pipe for unit lifting up
P	Finned pack heat exchanger protection grille

# Technical Characteristics



## Technical Characteristics

**Tab.2- Rated technical/electrical data of LCE CS water chillers, STANDARD version, mod. 042 - 124**

Approx. capacity	kW	45	50	60	70	80	90			100			120		
Efficiency pack	-	2	2	2	2	2	1	2	4	1	2	4	1	2	4
<b>LCE . . . CS</b>		<b>042</b>	<b>052</b>	<b>062</b>	<b>072</b>	<b>082</b>	<b>091</b>	<b>092</b>	<b>094</b>	<b>101</b>	<b>102</b>	<b>104</b>	<b>121</b>	<b>122</b>	<b>124</b>
Power supply	-	400 V / 3 Ph / 50 Hz													
Cooling capacity	kW	-	-	63,3	69,2	76,5	92,2	92,2	-	102,7	102,7	-	124,1	124,1	126,4
Total power input	kW	-	-	22,6	25,4	29,0	33,1	33,1	-	39,5	39,5	-	43,1	43,1	43,0
Rated current input	A	-	-	43,3	46,0	57,3	64,6	64,6	-	73,2	73,2	-	82,8	82,7	82,3
EER	-	-	-	2,80	2,73	2,64	2,79	2,79	-	2,60	2,60	-	2,88	2,88	2,94
ESEER	-	-	-	4,05	4,01	3,98	3,45	4,00	-	3,40	3,95	-	3,88	4,22	4,09
Maximum current input	A	-	-	60	64	75	91	91	-	101	101	-	119	119	120
Starting current	A	-	-	195	192	200	261	261	-	269	269	-	319	319	247
Scroll compressors / circuits	No.	-	-	2 / 1	2 / 1	2 / 1	2 / 1	2 / 1	-	2 / 2	2 / 1	-	2 / 2	2 / 1	4 / 2
Axial fans	No.	-	-	4	4	4	6	6	-	6	6	-	8	8	8
Air flow rate	m <sup>3</sup> /h	-	-	21379	21379	21379	30913	30913	-	30913	30913	-	41340	41340	41340
Water flow rate	l/h	-	-	10887	11902	13158	15858	15858	-	17665	17665	-	21346	21346	21747
Pressure drop, water side	kPa	-	-	46	34	42	31	31	-	38	38	-	39	39	41
Available head, standard pump	kPa	-	-	126	133	119	130	130	-	119	119	-	108	108	106
Buffer tank	dm <sup>3</sup>	-	-	200	200	200	220	220	-	220	220	-	340	340	340
Expansion tank	dm <sup>3</sup>	-	-	12	12	12	12	12	-	12	12	-	12	12	12
Plumbing connections	"	-	-	2	2	2	2	2	-	2	2	-	2 1/2	2 1/2	2 1/2
Height	mm	-	-	1720	1720	1720	1720	1720	-	1720	1720	-	1720	1720	1720
Length	mm	-	-	2010	2010	2010	2360	2360	-	2360	2360	-	3190	3190	3540
Depth	mm	-	-	1185	1185	1185	1185	1185	-	1185	1185	-	1185	1185	1185
Sound power level	dB(A)	-	-	80	80	80	82	82	-	82	82	-	82	82	82
Sound pressure level	dB(A)	-	-	52	52	52	54	54	-	54	54	-	54	54	54
Base unit operating weight	kg	-	-	540	570	650	730	730	-	730	730	-	1010	1010	1050
Operating weight with pump and full tank	kg	-	-	8747	907	987	1138	1138	-	1138	1138	-	1581	1581	1641

- Cooling mode: outdoor air temperature 35°C, water temperature 12°C / 7°C.
- Sound power measured according to standards ISO 3741 - ISO 3744 and EN 29614-1.
- Sound pressure measured at a distance of 10 m and a height of 1.5 m above the ground in a clear field.

Approx. cooling output	kW	45	50	60	70	80	90			100			120		
Efficiency pack	-	2	2	2	2	2	1	2	4	1	2	4	1	2	4
<b>LCE . . . CS</b>		<b>042</b>	<b>052</b>	<b>062</b>	<b>072</b>	<b>082</b>	<b>091</b>	<b>092</b>	<b>094</b>	<b>101</b>	<b>102</b>	<b>104</b>	<b>121</b>	<b>122</b>	<b>124</b>
Power supply	-	400 V / 3 Ph / 50 Hz													
Max. power input	kW	-	-	30,268	33,662	37,558	45,511	45,511	-	52,017	52,017	-	59,601	59,601	60,535
Max. current absorption	A	-	-	60,156	64,276	75,016	91,304	91,304	-	100,56	100,56	-	119,05	119,05	120,31
Start-up current	A	-	-	194,76	192,06	199,96	260,68	260,68	-	269,22	269,23	-	319,01	319,01	246,61
Start-up current with softstarter device	A	0	0	120,26	133,06	147,96	198,68	198,68	-	207,22	207,23	-	254,01	254,01	172,11
Fans	No.	-	-	4	4	4	6	6	-	6	6	-	8	8	8
Fans rated power input	kW	-	-	1,17	1,17	1,17	1,75	1,75	-	1,75	1,75	-	2,34	2,34	2,34
Fans rated current absorption	A	0	0	4,4	4,4	4,4	6,6	6,6	-	6,6	6,6	-	8,8	8,8	8,8
Standard pump rated power input	kW	-	-	1,36	1,36	1,36	1,82	1,82	-	1,82	1,82	-	1,82	1,82	1,82
Standard pump rated current absorption	A	-	-	2,5	2,5	2,5	3,4	3,4	-	3,4	3,4	-	3,4	3,4	3,4
Upated pump rated power input	kW	-	-	2,93	2,93	2,93	2,93	2,93	-	2,93	2,93	-	3,27	3,27	3,27
Upated pump rated current absorption	A	-	-	4,8	4,8	4,8	4,8	4,8	-	4,8	4,8	-	5,6	5,6	5,6
Standard AND pump rated power input	kW	-	-	2,6	2,6	2,6	2,72	2,72	-	2,72	2,72	-	2,72	2,72	2,72
Std. AND pump rated current absorpt.	A	-	-	5,4	5,4	5,4	5	5	-	5	5	-	5	5	5
Upated AND pump rated power input	kW	-	-	2,6	2,6	2,6	3,52	3,52	-	3,52	3,52	-	5,86	5,86	5,86
Upated AND pump rated current absorpt.	A	-	-	5,4	5,4	5,4	6,4	6,4	-	6,4	6,4	-	9,6	9,6	9,6
Auxiliary devices power supply	V	-	-	24	24	24	24	24	-	24	24	-	24	24	24

- The maximum electrical input is the mains electricity that must be available in order for the unit to work.
- The maximum current absorption refers to the current that will trigger the internal safety devices of the unit. It is the max. current allowed in the unit.
- This value may never be exceeded; it must be used as a reference for determining the size of the power supply line and the related safety devices (refer to the wiring diagram supplied with the units).

# Technical Characteristics



**Tab.3- Rated technical/electrical data of LCE CS water chillers, STANDARD version, mod. 141 - 324**

Approx. capacity	kW	140			160			170	190	210	240	270	290	320
Efficiency pack	-	1	2	2	1	2	4	4	4	4	4	4	4	4
<b>LCE . . . CS</b>		<b>141</b>	<b>142</b>	<b>144</b>	<b>161</b>	<b>162</b>	<b>164</b>	<b>174</b>	<b>194</b>	<b>214</b>	<b>244</b>	<b>274</b>	<b>294</b>	<b>324</b>
Power supply	-	400 V / 3 Ph / 50 Hz												
Cooling capacity	kW	138,4	138,4	140,4	155,0	155,0	153,4	162,0	186,6	209,0	236,9	271,6	295,5	313,9
Total power input	kW	48,2	48,2	47,8	58,6	58,6	56,0	56,8	70,7	83,3	92,9	104,2	112,8	120,2
Rated current input	A	92,5	92,3	87,1	103,9	103,9	111,1	115,8	135,6	152,3	172,7	192,4	184,7	190,8
EER	-	2,87	2,87	2,94	2,64	2,64	2,74	2,85	2,64	2,51	2,55	2,61	2,62	2,61
ESEER	-	3,93	4,18	4,10	3,61	3,87	3,75	4,16	4,04	4,00	4,01	4,10	4,12	4,18
Maximum current input	A	131	131	129	137	144	150	136	155	173	196	224	237	251
Starting current	A	330	330	245	389	396	266	252	310	330	380	403	468	476
Scroll compressors / circuits	No.	2 / 2	2 / 1	4 / 2	2 / 2	2 / 1	4 / 2	4 / 2	4 / 2	4 / 2	4 / 2	4 / 2	4 / 2	4 / 2
Axial fans	No.	8	8	8	8	8	8	6	6	6	6	8	8	8
Air flow rate	m <sup>3</sup> /h	39890	39890	39890	39890	39890	39890	67672	67672	67672	75478	103511	97902	97902
Water flow rate	l/h	23805	23805	24143	26660	26660	26378	27864	32095	35948	40747	46716	50827	53990
Pressure drop, water side	kPa	49	49	50	42	42	43	46	49	50	53	41	49	55
Available head, standard pump	kPa	150	150	147	147	147	148	155	133	147	171	170	152	137
Buffer tank	dm <sup>3</sup>	340	340	340	340	340	340	600	600	600	600	600	600	600
Expansion tank	dm <sup>3</sup>	12	12	12	12	12	12	24	24	24	24	24	24	24
Plumbing connections	"	2 1/2	2 1/2	2 1/2	2 1/2	2 1/2	2 1/2	3	3	3	4	4	4	4
Height	mm	1720	1720	1720	1720	1720	1720	1830	1830	1830	2174	2174	2174	2174
Length	mm	3190	3190	3540	3190	3190	3540	3540	3540	3540	3540	4296	4296	4296
Depth	mm	1185	1185	1185	1185	1185	1185	1654	1654	1654	1654	1654	1654	1654
Sound power level	dB(A)	82	82	82	82	82	82	83	83	83	83	84	84	84
Sound pressure level	dB(A)	54	54	54	54	54	54	55	55	55	55	56	56	56
Base unit operating weight	kg	1055	1055	1070	1085	1085	1220	1440	1460	1470	1620	1880	1912	1947
Operating weight with pump and full tank	kg	1626	1626	1661	1656	1656	1811	2208	2276	2286	2469	2894	2926	2961

- Cooling mode: outdoor air temperature 35°C, water temperature 12°C / 7°C.
- Sound power measured according to standards ISO 3741 - ISO 3744 and EN 29614-1.
- Sound pressure measured at a distance of 10 m and a height of 1.5 m above the ground in a clear field.

Approx. cooling output	kW	140			160			170	190	210	240	270	290	320
Efficiency pack	-	1	2	2	1	2	4	4	4	4	4	4	4	4
<b>LCE . . . CS</b>		<b>141</b>	<b>142</b>	<b>144</b>	<b>161</b>	<b>162</b>	<b>164</b>	<b>174</b>	<b>194</b>	<b>214</b>	<b>244</b>	<b>274</b>	<b>294</b>	<b>324</b>
Power supply	-	400 V / 3 Ph / 50 Hz												
Max. power input	kW	65,737	65,737	67,323	75,129	76,577	75,115	75,384	88,396	101,41	113,68	127,97	138,81	149,65
Max. current absorption	A	130,51	130,51	128,55	136,94	143,97	150,03	136,32	154,84	173,36	196,28	224	237,46	250,92
Start-up current	A	329,91	329,86	245,21	388,58	395,61	265,81	252,1	309,71	330,2	379,96	403,24	467,92	475,96
Start-up current with softstarter device	A	264,91	264,86	186,21	305,58	312,61	213,81	200,1	247,71	268,2	314,96	338,24	384,92	392,96
Fans	No.	8	8	8	8	8	8	6	6	6	6	8	8	8
Fans rated power input	kW	2,34	2,34	2,34	2,34	2,34	2,34	6,3	6,3	6,3	6,3	8,4	8,4	8,4
Fans rated current absorption	A	8,8	8,8	8,8	8,8	8,8	8,8	15	15	15	15	20	20	20
Standard pump rated power input	kW	2,93	2,93	2,93	2,93	2,93	2,93	2,8	2,8	3,7	5,1	5,1	5,1	5,1
Standard pump rated current absorption	A	4,8	4,8	4,8	4,8	4,8	4,8	4,8	4,8	6,8	9,2	9,2	9,2	9,2
Up-rated pump rated power input	kW	3,27	3,27	3,27	3,27	3,27	3,27	3,7	5,1	5,1	9,1	9,1	9,1	9,1
Up-rated pump rated current absorption	A	5,6	5,6	5,6	5,6	5,6	5,6	6,8	9,2	9,2	15,5	15,5	15,5	15,5
Standard AND pump rated power input	kW	2,72	2,72	2,72	2,72	2,72	2,72	4	4	4	5,6	5,6	5,6	5,6
Std. AND pump rated current absorpt.	A	5	5	5	5	5	5	6,8	6,8	6,8	9,6	9,6	9,6	9,6
Up-rated AND pump rated power input	kW	5,86	5,86	5,86	5,86	5,86	5,86	5,6	5,6	5,6	7,4	7,4	7,4	7,4
Up-rated AND pump rated current absorpt.	A	9,6	9,6	9,6	9,6	9,6	9,6	9,6	9,6	9,6	13,6	13,6	13,6	13,6
Auxiliary devices power supply	V	24	24	24	24	24	24	24	24	24	24	24	24	24

- The maximum electrical input is the mains electricity that must be available in order for the unit to work.
- The maximum current absorption refers to the current that will trigger the internal safety devices of the unit. It is the max. current allowed in the unit.
- This value may never be exceeded; it must be used as a reference for determining the size of the power supply line and the related safety devices (refer to the wiring diagram supplied with the units).

# Technical Characteristics



**Tab.4- Rated technical/electrical data of LCE CL water chillers, LOW NOISE version, mod. 042 - 124**

Approx. capacity	kW	45	50	60	70	80	90			100			120		
Efficiency pack	-	2	2	2	2	2	1	2	4	1	2	4	1	2	4
<b>LCE . . . CL</b>		<b>042</b>	<b>052</b>	<b>062</b>	<b>072</b>	<b>082</b>	<b>091</b>	<b>092</b>	<b>094</b>	<b>101</b>	<b>102</b>	<b>104</b>	<b>121</b>	<b>122</b>	<b>124</b>
Power supply	-	400 V / 3 Ph / 50 Hz													
Cooling capacity	kW	48,0	52,2	63,7	69,9	77,4	92,9	92,9	94,3	103,4	103,4	102,2	125,1	125,1	127,4
Total power input	kW	16,2	18,6	22,0	24,7	28,2	32,0	32,0	32,3	38,4	38,4	37,1	44,4	44,4	44,2
Rated current input	A	32,6	32,7	42,4	45,1	56,2	62,7	62,7	64,7	71,2	71,2	70,2	81,2	81,1	80,5
EER	-	2,97	2,82	2,90	2,83	2,75	2,90	2,90	2,92	2,70	2,70	2,76	2,82	2,82	2,88
ESEER	-	4,06	4,04	4,05	4,01	3,98	3,45	4,00	3,90	3,40	3,95	3,85	3,88	4,22	4,09
Maximum current input	A	41	44	51	55	66	77	77	81	86	86	87	95	95	96
Starting current	A	159	162	185	183	191	246	246	194	254	254	198	295	295	220
Scroll compressors / circuits	No.	2/1	2/1	2/1	2/1	2/1	2/1	2/1	4/2	2/2	2/1	4/2	2/2	2/1	4/2
Axial fans	No.	4	4	6	6	6	8	8	8	8	8	8	6	6	6
Air flow rate	m <sup>3</sup> /h	15398	15398	21955	21955	21955	29393	29393	29393	29393	29393	29393	43434	43434	43434
Water flow rate	l/h	8261	8983	10956	12027	13313	15986	15986	16213	17778	17778	17582	21518	21518	21906
Pressure drop, water side	kPa	27	31	47	35	43	32	32	33	39	39	38	40	40	41
Available head, standard pump	kPa	157	149	125	131	117	129	129	128	118	118	119	107	107	105
Buffer tank	dm <sup>3</sup>	200	200	220	220	220	340	340	340	340	340	340	600	600	600
Expansion tank	dm <sup>3</sup>	12	12	12	12	12	12	12	12	12	12	12	24	24	24
Plumbing connections	"	2	2	2	2	2	2 1/2	2 1/2	2 1/2	2 1/2	2 1/2	2 1/2	3	3	3
Height	mm	1720	1720	1720	1720	1720	1720	1720	1720	1720	1720	1705	1830	1830	1830
Length	mm	2010	2010	2360	2360	2360	3190	3190	3540	3190	3190	3540	3540	3540	3540
Depth	mm	1185	1185	1185	1185	1185	1185	1185	1185	1185	1185	1185	1654	1654	1654
Sound power level	dB(A)	70	70	72	72	72	73	73	73	73	73	73	77	77	77
Sound pressure level	dB(A)	42	42	44	44	44	45	45	45	45	45	45	49	49	49
Base unit operating weight	kg	525	525	630	635	700	905	905	980	915	915	980	1260	1260	1275
Operating weight with pump and full tank	kg	862	862	982	987	1067	1426	1426	1557	1436	1436	1557	2040	2040	2055

- Cooling mode: outdoor air temperature 35°C, water temperature 12°C / 7°C.
- Sound power measured according to standards ISO 3741 - ISO 3744 and EN 29614-1.
- Sound pressure measured at a distance of 10 m and a height of 1.5 m above the ground in a clear field.

Approx. cooling output	kW	45	50	60	70	80	90			100			120		
Efficiency pack	-	2	2	2	2	2	1	2	4	1	2	4	1	2	4
<b>LCE . . . CL</b>		<b>042</b>	<b>052</b>	<b>062</b>	<b>072</b>	<b>082</b>	<b>091</b>	<b>092</b>	<b>094</b>	<b>101</b>	<b>102</b>	<b>104</b>	<b>121</b>	<b>122</b>	<b>124</b>
Power supply	-	400 V / 3 Ph / 50 Hz													
Max. power input	kW	22,067	24,535	28,499	31,893	35,789	42,67	42,67	44,134	49,176	49,176	49,07	56,21	56,21	57,144
Max. current absorption	A	40,564	43,524	51,086	55,206	65,946	76,868	76,868	81,128	86,128	86,128	87,048	95,02	95,02	96,28
Start-up current	A	159,37	161,67	185,49	182,69	190,69	246,05	246,05	194,25	254,25	254,25	198,45	294,68	295,38	220,48
Start-up current with softstarter device	A	87,574	100,67	110,99	123,69	138,69	184,05	184,05	122,45	192,25	192,25	137,45	229,68	230,38	145,98
Fans	No.	4	4	6	6	6	8	8	8	8	8	8	6	6	6
Fans rated power input	kW	0,54	0,54	0,81	0,81	0,81	1,08	1,08	1,08	1,08	1,08	1,08	4,02	4,02	4,02
Fans rated current absorption	A	2,54	2,54	3,84	3,84	3,84	5,12	5,12	5,12	5,12	5,12	5,12	7,74	7,74	7,74
Std. pump rated power input	kW	1,36	1,36	1,36	1,36	1,36	1,82	1,82	1,82	1,82	1,82	1,82	1,82	1,82	1,82
Standard pump rated current absorption	A	2,5	2,5	2,5	2,5	2,5	3,4	3,4	3,4	3,4	3,4	3,4	3,4	3,4	3,4
Uprat. pump rated power input	kW	1,76	1,76	2,93	2,93	2,93	2,93	2,93	2,93	2,93	2,93	2,93	3,27	3,27	3,27
Uprat. pump rated current absorption	A	3,2	3,2	4,8	4,8	4,8	4,8	4,8	4,8	4,8	4,8	4,8	5,6	5,6	5,6
Standard AND pump rated power input	kW	2,6	2,6	2,6	2,6	2,6	2,72	2,72	2,72	2,72	2,72	2,72	2,72	2,72	2,72
Std. AND pump rated current absorption	A	5,4	5,4	5,4	5,4	5,4	5	5	5	5	5	5	5	5	5
Uprat. AND pump rated power input	kW	2,6	2,6	2,6	2,6	2,6	3,52	3,52	3,52	3,52	3,52	3,52	5,86	5,86	5,86
Uprat. AND pump rated current absorption	A	5,4	5,4	5,4	5,4	5,4	6,4	6,4	6,4	6,4	6,4	6,4	9,6	9,6	9,6
Auxiliary devices power supply	V	24	24	24	24	24	24	24	24	24	24	24	24	24	24

- The maximum electrical input is the mains electricity that must be available in order for the unit to work.
- The maximum current absorption refers to the current that will trigger the internal safety devices of the unit. It is the max. current allowed in the unit.
- This value may never be exceeded; it must be used as a reference for determining the size of the power supply line and the related safety devices (refer to the wiring diagram supplied with the units).

# Technical Characteristics



**Tab.5- Rated technical/electrical data of LCE CL water chillers, LOW NOISE version, mod. 141-324**

Approx. capacity	kW	140			160			170	190	210	240	270	290	320
Efficiency pack	-	1	2	2	1	2	4	4	4	4	4	4	4	4
<b>LCE . . . CL</b>		<b>141</b>	<b>142</b>	<b>144</b>	<b>161</b>	<b>162</b>	<b>164</b>	<b>NA</b>	<b>194</b>	<b>214</b>	<b>244</b>	<b>274</b>	<b>294</b>	<b>324</b>
Power supply	-	400 V / 3 Ph / 50 Hz												
Cooling capacity	kW	137,5	137,5	139,8	155,4	155,4	153,7	-	181,2	211,9	230,3	265,3	287,4	304,4
Total power input	kW	50,3	50,3	49,7	60,2	60,2	57,6	-	71,4	79,5	94,5	105,2	114,9	122,9
Rated current input	A	91,6	91,7	86,4	102,7	102,7	109,8	-	131,9	143,8	170,2	189,7	200,9	208,3
EER	-	2,74	2,74	2,81	2,58	2,58	2,67	-	2,54	2,67	170,20	2,52	2,50	2,48
ESEER	-	3,93	4,18	4,10	3,61	3,87	3,75	-	4,04	4,00	4,01	4,10	4,12	4,18
Maximum current input	A	106	106	105	120	120	126	-	148	167	190	215	229	242
Starting current	A	306	306	222	371	371	241	-	307	318	382	398	494	472
Scroll compressors / circuits	No.	2/2	2/1	4/2	2/2	2/1	4/2	-	4/2	4/2	4/2	4/2	4/2	4/2
Axial fans	No.	6	6	6	6	6	6	-	6	6	6	8	8	8
Air flow rate	m <sup>3</sup> /h	43434	43434	43434	40235	40235	40235	-	55808	63261	63261	87186	81687	81687
Water flow rate	l/h	23655	23655	24043	26719	26719	26434	-	31172	36451	36615	45628	49438	52350
Pressure drop, water side	kPa	48	48	50	43	43	43	-	47	51	50	39	46	52
Available head, standard pump	kPa	151	151	148	147	147	148	-	139	143	177	174	158	145
Buffer tank	dm <sup>3</sup>	600	600	600	600	600	600	-	600	600	600	600	600	600
Expansion tank	dm <sup>3</sup>	24	24	24	24	24	24	-	24	24	24	24	24	24
Plumbing connections	"	3	3	3	3	3	3	-	3	4	4	4	4	4
Height	mm	1830	1830	1830	1830	1830	1830	-	1830	2174	2174	2174	2174	2174
Length	mm	3540	3540	3540	3540	3540	3540	-	3540	3540	3540	4296	4296	4296
Depth	mm	1654	1654	1654	1654	1654	1654	-	1654	1654	1654	1654	1654	1654
Sound power level	dB(A)	77	77	77	77	77	77	-	77	77	78	79	79	79
Sound pressure level	dB(A)	49	49	49	49	49	49	-	49	49	50	51	51	51
Base unit operating weight	kg	1310	1310	1290	1330	1330	1440	-	1460	1510	1620	1880	1912	1947
Operating weight with pump and full tank	kg	2090	2090	2070	2110	2110	2220	-	2276	2326	2469	2894	2926	2961

- Cooling mode: outdoor air temperature 35°C, water temperature 12°C / 7°C.
- Sound power measured according to standards ISO 3741 - ISO 3744 and EN 29614-1.
- Sound pressure measured at a distance of 10 m and a height of 1.5 m above the ground in a clear field.

Approx. cooling output	kW	140			160			170	190	210	240	270	290	320
Efficiency pack	-	1	2	2	1	2	4	4	4	4	4	4	4	
<b>LCE . . . CL</b>		<b>141</b>	<b>142</b>	<b>144</b>	<b>161</b>	<b>162</b>	<b>164</b>	<b>174</b>	<b>194</b>	<b>214</b>	<b>244</b>	<b>274</b>	<b>294</b>	<b>324</b>
Power supply	-	400 V / 3 Ph / 50 Hz												
Max. power input	kW	62,346	62,346	63,932	73,186	73,186	71,724	-	86,536	99,548	111,82	125,49	136,33	147,17
Max. current absorption	A	106,48	106,48	104,52	119,94	119,94	126	-	148,42	166,94	189,86	215,44	228,9	242,36
Start-up current	A	306,18	306,13	222,38	371,38	371,33	241,48	-	306,95	318,35	381,76	397,71	463,65	472,42
Start-up current with softstarter device	A	241,18	241,13	163,38	288,38	288,33	189,48	-	244,95	256,35	316,76	332,71	380,65	389,42
Fans	No.	6	6	6	6	6	6	-	6	6	6	8	8	8
Fans rated power input	kW	4,02	4,02	4,02	4,02	4,02	4,02	-	4,02	4,02	4,02	6,1	6,1	6,1
Fans rated current absorption	A	7,74	7,74	7,74	7,74	7,74	7,74	-	7,74	7,74	7,74	10,3	10,3	10,3
Standard pump rated power input	kW	2,93	2,93	2,93	2,93	2,93	2,93	-	2,8	3,7	5,1	5,1	5,1	5,1
Standard pump rated current absorption	A	4,8	4,8	4,8	4,8	4,8	4,8	-	4,8	6,8	9,2	9,2	9,2	9,2
Up-rated pump rated power input	kW	3,27	3,27	3,27	3,27	3,27	3,27	-	5,1	5,1	9,1	9,1	9,1	9,1
Up-rated pump rated current absorption	A	5,6	5,6	5,6	5,6	5,6	5,6	-	9,2	9,2	15,5	15,5	15,5	15,5
Standard AND pump rated power input	kW	2,72	2,72	2,72	2,72	2,72	2,72	-	4	4	5,6	5,6	5,6	5,6
Std. AND pump rated current absorpt.	A	5	5	5	5	5	5	-	6,8	6,8	9,6	9,6	9,6	9,6
Up-rated AND pump rated power input	kW	5,86	5,86	5,86	5,86	5,86	5,86	-	5,6	5,6	7,4	7,4	7,4	7,4
Up-rated AND pump rated current absorpt.	A	9,6	9,6	9,6	9,6	9,6	9,6	-	9,6	9,6	13,6	13,6	13,6	13,6
Auxiliary devices power supply	V	24	24	24	24	24	24	-	24	24	24	24	24	24

- The maximum electrical input is the mains electricity that must be available in order for the unit to work.
- The maximum current absorption refers to the current that will trigger the internal safety devices of the unit. It is the max. current allowed in the unit.
- This value may never be exceeded; it must be used as a reference for determining the size of the power supply line and the related safety devices (refer to the wiring diagram supplied with the units).

# Technical Characteristics



**Tab.6- Rated technical/electrical data of LCE CQ water chillers, QUIET version, mod. 042-124**

Approx. capacity	kW	45	50	60	70	80	90			100			120		
Efficiency pack	-	2	2	2	2	2	1	2	4	1	2	4	1	2	4
<b>LCE . . . CQ</b>		<b>042</b>	<b>052</b>	<b>062</b>	<b>072</b>	<b>082</b>	<b>091</b>	<b>092</b>	<b>094</b>	<b>101</b>	<b>102</b>	<b>104</b>	<b>121</b>	<b>122</b>	<b>124</b>
Power supply	-	400 V / 3 Ph / 50 Hz													
Cooling capacity	kW	48,0	52,2	63,7	69,9	77,4	92,9	92,9	94,3	103,4	103,4	102,2	123,6	123,6	125,7
Total power input	kW	16,2	18,6	22,0	24,7	28,2	32,0	32,0	32,3	38,4	35,4	37,1	45,0	38,4	45,0
Rated current input	A	32,6	32,7	42,4	45,1	56,2	62,7	62,7	64,7	71,2	71,2	64,7	82,1	82,0	70,2
EER	-	2,97	2,82	2,90	2,83	2,75	2,90	2,90	2,92	2,70	2,92	2,76	2,74	3,22	2,79
ESEER	-	4,06	4,04	4,05	4,01	3,98	3,45	4,00	3,90	3,40	3,95	3,85	3,88	4,22	4,09
Maximum current input	A	41	44	51	55	66	77	77	81	86	86	87	95	95	96
Starting current	A	159	162	185	183	191	246	246	194	254	254	198	295	295	220
Scroll compressors / circuits	No.	2/1	2/1	2/1	2/1	2/1	2/2	2/1	4/2	2/2	2/1	4/2	2/2	2/1	4/2
Axial fans	No.	4	4	6	6	6	8	8	8	8	8	8	6	6	6
Air flow rate	m <sup>3</sup> /h	15398	15398	21955	21955	21955	29393	29393	29393	29393	29393	29393	35930	35930	35930
Water flow rate	l/h	8261	8983	10956	12027	13313	15986	15986	16213	17778	17778	17582	21259	21259	21623
Pressure drop, water side	kPa	27	31	47	35	43	32	32	33	39	39	38	39	39	40
Available head, standard pump	kPa	157	149	125	131	117	129	129	128	118	118	119	109	109	106
Buffer tank	dm <sup>3</sup>	200	200	220	220	220	340	340	340	340	340	340	600	600	600
Expansion tank	dm <sup>3</sup>	12	12	12	12	12	12	12	12	12	12	12	24	24	24
Plumbing connections	"	2	2	2	2	2	2 1/2	2 1/2	2 1/2	2 1/2	2 1/2	2 1/2	3	3	3
Height	mm	1720	1720	1720	1720	1720	1720	1720	1720	1720	1720	1720	1830	1830	1830
Length	mm	2010	2010	2360	2360	2360	3190	3190	3540	3190	3190	3540	3540	3540	3540
Depth	mm	1185	1185	1185	1185	1185	1185	1185	1185	1185	1185	1185	1654	1654	1654
Sound power level	dB(A)	67	67	69	69	69	70	70	70	70	70	70	69	69	69
Sound pressure level	dB(A)	39	39	41	41	41	42	42	42	42	42	42	41	41	41
Base unit operating weight	kg	525	525	630	635	700	905	905	980	915	915	980	1260	1260	1275
Operating weight with pump and full tank	kg	862	862	982	987	1067	1426	1426	1557	1436	1436	1557	2040	2040	2055

- Cooling mode: outdoor air temperature 35°C, water temperature 12°C / 7°C.
- Sound power measured according to standards ISO 3741 - ISO 3744 and EN 29614-1.
- Sound pressure measured at a distance of 10 m and a height of 15 m above the ground in a clear field.

Approx. cooling output	kW	45	50	60	70	80	90			100			120		
Efficiency pack	-	2	2	2	2	2	1	2	4	1	2	4	1	2	4
<b>LCE . . . CQ</b>		<b>042</b>	<b>052</b>	<b>062</b>	<b>072</b>	<b>082</b>	<b>091</b>	<b>092</b>	<b>094</b>	<b>101</b>	<b>102</b>	<b>104</b>	<b>121</b>	<b>122</b>	<b>124</b>
Power supply	-	400 V / 3 Ph / 50 Hz													
Max. power input	kW	22,067	24,535	28,499	31,893	35,789	42,67	42,67	44,134	49,176	49,176	49,07	58,01	58,01	58,944
Max. current absorption	A	40,564	43,524	51,086	55,206	65,946	76,868	76,868	81,128	86,128	86,128	87,048	98,92	98,92	100,18
Start-up current	A	159,37	161,67	185,49	182,69	190,69	246,05	246,05	194,25	254,25	254,25	198,45	298,68	299,48	224,68
Start-up current with softstarter device	A	87,574	100,67	110,99	123,69	138,69	184,05	184,05	122,45	192,25	192,25	137,45	233,68	234,48	150,18
Fans	No.	0,54	0,54	0,81	0,81	0,81	1,08	1,08	1,08	1,08	1,08	1,08	4,02	4,02	4,02
Fans rated power input	kW	2,56	2,56	3,84	3,84	3,84	5,12	5,12	5,12	5,12	5,12	5,12	7,74	7,74	7,74
Fans rated current absorption	A	1,36	1,36	1,36	1,36	1,36	1,82	1,82	1,82	1,82	1,82	1,82	1,82	1,82	1,82
Std. pump rated power input	kW	1,36	1,36	1,36	1,36	1,36	1,82	1,82	1,82	1,82	1,82	1,82	1,82	1,82	1,82
Standard pump rated current absorption	A	2,5	2,5	2,5	2,5	2,5	3,4	3,4	3,4	3,4	3,4	3,4	3,4	3,4	3,4
Uprat. pump rated power input	kW	1,76	1,76	2,93	2,93	2,93	2,93	2,93	2,93	2,93	2,93	2,93	3,27	3,27	3,27
Uprat. pump rated current absorption	A	3,2	3,2	4,8	4,8	4,8	4,8	4,8	4,8	4,8	4,8	4,8	5,6	5,6	5,6
Standard AND pump rated power input	kW	2,6	2,6	2,6	2,6	2,6	2,72	2,72	2,72	2,72	2,72	2,72	2,72	2,72	2,72
Std. AND pump rated current absorption	A	5,4	5,4	5,4	5,4	5,4	5	5	5	5	5	5	5	5	5
Uprat. AND pump rated power input	kW	2,6	2,6	2,6	2,6	2,6	3,52	3,52	3,52	3,52	3,52	3,52	5,86	5,86	5,86
Uprat. AND pump rated current absorption	A	5,4	5,4	5,4	5,4	5,4	6,4	6,4	6,4	6,4	6,4	6,4	9,6	9,6	9,6
Auxiliary devices power supply	V	24	24	24	24	24	24	24	24	24	24	24	24	24	24

- The maximum electrical input is the mains electricity that must be available in order for the unit to work.
- The maximum current absorption refers to the current that will trigger the internal safety devices of the unit. It is the max current allowed in the unit.
- This value may never be exceeded; it must be used as a reference for determining the size of the power supply line and the related safety devices (refer to the wiring diagram supplied with the units).

# Technical Characteristics



**Tab.7- Rated technical/electrical data of LCE CQ water chillers, QUIET version, mod. 141-324**

Approx. capacity	kW	140			160			170	190	210	240	270	290	320
Efficiency pack	-	1	2	2	1	2	4	4	4	4	4	4	4	4
<b>LCE . . . CQ</b>		<b>141</b>	<b>142</b>	<b>144</b>	<b>161</b>	<b>162</b>	<b>164</b>	<b>174</b>	<b>194</b>	<b>214</b>	<b>244</b>	<b>274</b>	<b>294</b>	<b>324</b>
Power supply	-	400 V / 3 Ph / 50 Hz												
Cooling capacity	kW	135,5	135,5	137,6	151,5	151,5	150,1	-	164,4	192,7	209,6	260,7	278,7	293,8
Total power input	kW	51,1	51,1	50,8	62,0	62,0	59,4	-	81,1	90,8	98,7	105,6	117,3	126,1
Rated current input	A	92,9	92,8	81,6	105,2	105,2	112,0	-	144,2	158,2	173,4	190,5	203,8	212,6
EER	-	2,65	2,65	2,71	2,44	2,44	2,53	-	2,03	2,12	2,12	2,47	2,38	2,33
ESEER	-	3,93	4,18	4,10	3,61	3,87	3,75	-	4,04	4,00	4,01	4,10	4,12	4,18
Maximum current input	A	106	106	105	120	120	126	-	148	167	190	215	229	242
Starting current	A	306	306	222	317	317	241	-	307	318	382	398	494	472
Scroll compressors / circuits	No.	2/2	2/1	4/2	2/2	2/1	4/2	-	4/2	4/2	4/2	4/2	4/2	4/2
Axial fans	No.	6	6	6	6	6	6	-	6	6	6	8	8	8
Air flow rate	m <sup>3</sup> /h	35930	35930	35930	35930	35930	35930	-	35930	40953	40953	69835	69835	69835
Water flow rate	l/h	23303	23303	23667	26051	26051	25816	-	28282	33135	36054	44837	47938	50535
Pressure drop, water side	kPa	47	47	48	41	41	40	-	39	39	42	38	44	48
Available head, standard pump	kPa	153	153	151	151	151	152	-	161	171	193	177	164	153
Buffer tank	dm <sup>3</sup>	600	600	600	600	600	600	-	600	600	600	600	600	600
Expansion tank	dm <sup>3</sup>	24	24	24	24	24	24	-	24	24	24	24	24	24
Plumbing connections	"	3	3	3	3	3	3	-	3	4	4	4	4	4
Height	mm	1830	1830	1830	1830	1830	1830	-	1830	2174	2174	2174	2174	2174
Length	mm	3540	3540	3540	3540	3540	3540	-	3540	3540	3540	4296	4296	4296
Depth	mm	1654	1654	1654	1654	1654	1654	-	1654	1654	1654	1654	1654	1654
Sound power level	dB(A)	69	69	69	69	69	69	-	69	69	69	70	70	70
Sound pressure level	dB(A)	41	41	41	41	41	41	-	41	41	41	42	42	42
Base unit operating weight	kg	1310	1310	1290	1330	1330	1440	-	1460	1510	1620	1880	1912	1947
Operating weight with pump and full tank	kg	2090	2090	2070	2110	2110	2220	-	2276	2326	2469	2894	2926	2961

- Cooling mode: outdoor air temperature 35°C, water temperature 12°C / 7°C.
- Sound power measured according to standards ISO 3741 - ISO 3744 and EN 29614-1.
- Sound pressure measured at a distance of 10 m and a height of 15 m above the ground in a clear field.

Approx. cooling output	kW	140			160			170	190	210	240	270	290	320
Efficiency pack	-	1	2	2	1	2	4	4	4	4	4	4	4	4
<b>LCE . . . CQ</b>		<b>141</b>	<b>142</b>	<b>144</b>	<b>161</b>	<b>162</b>	<b>164</b>	<b>174</b>	<b>194</b>	<b>214</b>	<b>244</b>	<b>274</b>	<b>294</b>	<b>324</b>
Power supply	-	400 V / 3 Ph / 50 Hz												
Max. power input	kW	64,146	64,146	65,732	74,986	74,986	73,524	-	86,536	99,548	111,82	124,09	134,93	145,77
Max. current absorption	A	110,38	110,38	108,42	123,84	123,84	129,9	-	148,42	166,94	189,86	212,78	226,24	239,7
Start-up current	A	310,28	310,28	226,73	376,58	376,58	247,03	-	313,84	327,83	394,72	396,35	465,35	475,13
Start-up current with softstarter device	A	245,28	245,28	167,73	293,58	293,58	195,03	-	251,84	265,83	329,72	331,35	382,35	392,13
Fans	No.	6	6	6	6	6	6	-	6	6	6	8	8	8
Fans rated power input	kW	4,02	4,02	4,02	4,02	4,02	4,02	-	4,02	4,02	4,02	4	4	4
Fans rated current absorption	A	7,74	7,74	7,74	7,74	7,74	7,74	-	7,74	7,74	7,74	7,2	7,2	7,2
Standard pump rated power input	kW	2,93	2,93	2,93	2,93	2,93	2,93	-	2,8	3,7	5,1	5,1	5,1	5,1
Standard pump rated current absorption	A	4,8	4,8	4,8	4,8	4,8	4,8	-	4,8	6,8	9,2	9,2	9,2	9,2
Up-rated pump rated power input	kW	3,27	3,27	3,27	3,27	3,27	3,27	-	5,1	5,1	9,1	9,1	9,1	9,1
Up-rated pump rated current absorption	A	5,6	5,6	5,6	5,6	5,6	5,6	-	9,2	9,2	15,5	15,5	15,5	15,5
Standard AND pump rated power input	kW	2,72	2,72	2,72	2,72	2,72	2,72	-	4	4	5,6	5,6	5,6	5,6
Std. AND pump rated current absorpt.	A	5	5	5	5	5	5	-	6,8	6,8	9,6	9,6	9,6	9,6
Up-rated AND pump rated power input	kW	5,86	5,86	5,86	5,86	5,86	5,86	-	5,6	5,6	7,4	7,4	7,4	7,4
Up-rated AND pump rated current absorpt.	A	9,6	9,6	9,6	9,6	9,6	9,6	-	9,6	9,6	13,6	13,6	13,6	13,6
Auxiliary devices power supply	V	24	24	24	24	24	24	-	24	24	24	24	24	24

- The maximum electrical input is the mains electricity that must be available in order for the unit to work.
- The maximum current absorption refers to the current that will trigger the internal safety devices of the unit. It is the max current allowed in the unit.
- This value may never be exceeded; it must be used as a reference for determining the size of the power supply line and the related safety devices (refer to the wiring diagram supplied with the units).

# Technical Characteristics



**Tab.8- Rated technical/electrical data of LCE HS reversible heat pumps, STANDARD version, mod. 042-124**

Approx. capacity	kW	45	50	60	70	80	90			100			120		
Efficiency pack	-	2	2	2	2	2	1	2	4	1	2	4	1	2	4
<b>LCE . . . HS</b>		<b>042</b>	<b>052</b>	<b>062</b>	<b>072</b>	<b>082</b>	<b>091</b>	<b>092</b>	<b>094</b>	<b>101</b>	<b>102</b>	<b>104</b>	<b>121</b>	<b>122</b>	<b>124</b>
Power supply	-	400 V / 3 Ph / 50 Hz													
Cooling capacity	kW	-	-	63,3	69,2	76,5	92,2	92,2	-	102,7	102,7	-	124,1	124,1	126,4
Total power input (cooling mode)	kW	-	-	22,6	25,4	29,0	33,1	33,1	-	39,5	39,5	-	43,1	43,1	43,0
Rated current input	A	-	-	42,3	46,1	57,3	64,6	64,6	-	73,2	73,2	-	82,8	82,7	82,3
EER	-	-	-	2,80	2,73	2,64	2,79	2,79	-	2,60	2,60	-	2,88	2,88	2,94
ESEER	-	-	-	4,05	4,01	3,98	3,45	4,00	-	3,40	3,95	-	3,88	4,22	4,09
Heating capacity	kW	-	-	70,2	77,6	85,2	101,6	101,6	-	118,2	118,2	-	138,1	138,1	135,3
Total power input (heating mode)	kW	-	-	21,5	24,4	27,4	32,8	32,8	-	37,8	37,8	-	43,1	43,1	42,7
Rated current input	A	-	-	42,9	44,2	54,9	62,8	62,8	-	69,2	69,2	-	81,0	80,7	80,0
COP	-	-	-	3,27	3,18	3,11	3,10	3,10	-	3,13	3,13	-	3,20	3,20	3,17
Maximum current input	A	-	-	60	64	75	91	91	-	101	101	-	119	119	120
Starting current	A	-	-	195	192	200	261	261	-	269	269	-	319	319	247
Scroll compressors / circuits	No.	-	-	2/1	2/1	2/1	2/1	2/1	-	2/2	2/1	-	2/2	2/1	4/2
Axial fans	No.	-	-	4	4	4	6	6	-	6	6	-	8	8	8
Air flow rate	m <sup>3</sup> /h	-	-	21379	21379	21379	30913	30913	-	30913	30913	-	41340	41340	41340
Water flow rate (cooling)	l/h	-	-	10887	11902	13158	15858	15858	-	17665	17665	-	21346	21346	21747
Pressure drop, water side (cooling)	kPa	-	-	46	34	42	31	31	-	38	38	-	39	39	41
Available head, std. pump (cooling)	kPa	-	-	126	133	119	130	130	-	119	119	-	108	108	106
Buffer tank	dm <sup>3</sup>	-	-	200	200	200	220	220	-	220	220	-	340	340	340
Expansion tank	dm <sup>3</sup>	-	-	12	12	12	12	12	-	12	12	-	12	12	12
Plumbing connections	"	-	-	2	2	2	2	2	-	2	2	-	2 1/2	2 1/2	2 1/2
Height	mm	-	-	1720	1720	1720	1720	1720	-	1720	1720	-	1720	1720	1720
Length	mm	-	-	2010	2010	2010	2360	2360	-	2360	2360	-	3190	3190	3540
Depth	mm	-	-	1185	1185	1185	1185	1185	-	1185	1185	-	1185	1185	1185
Sound power level	dB(A)	-	-	80	80	80	82	82	-	82	82	-	82	82	82
Sound pressure level	dB(A)	-	-	52	52	52	54	54	-	54	54	-	54	54	54
Base unit operating weight	kg	-	-	540	570	650	730	730	-	730	730	-	1010	1010	1050
Unit with pump, full tank operating weight	kg	-	-	8747	907	987	1138	1138	-	1138	1138	-	1581	1581	1641

- Cooling mode: outdoor air temperature 35°C, water temperature 12°C / 7°C.
- Heating mode: outdoor air temperature 7°C dry bulb and 6,2°C wet bulb, water temperature 40°C / 45°C.
- Sound power measured according to standards ISO 3741 - ISO 3744 and EN 29614-1.
- Sound pressure measured at a distance of 10 m and a height of 15 m above the ground in a clear field.

Approx. cooling output	kW	45	50	60	70	80	90			100			120		
Efficiency pack	-	2	2	2	2	2	1	2	4	1	2	4	1	2	4
<b>LCE . . . HS</b>		<b>042</b>	<b>052</b>	<b>062</b>	<b>072</b>	<b>082</b>	<b>091</b>	<b>092</b>	<b>094</b>	<b>101</b>	<b>102</b>	<b>104</b>	<b>121</b>	<b>122</b>	<b>124</b>
Power supply	-	400 V / 3 Ph / 50 Hz													
Max. power input	kW	-	-	30,268	33,662	37,558	45,511	45,511	-	52,017	52,017	-	59,601	59,601	60,535
Max. current absorption	A	-	-	60,156	64,276	75,016	91,304	91,304	-	100,56	100,56	-	119,05	119,05	120,31
Start-up current	A	-	-	194,76	192,06	199,96	260,68	260,68	-	269,22	269,23	-	319,01	319,01	246,61
Start-up current with softstarter device	A	0	0	120,26	133,06	147,96	198,68	198,68	-	207,22	207,23	-	254,01	254,01	172,11
Fans	No.	-	-	4	4	4	6	6	-	6	6	-	8	8	8
Fans rated power input	kW	-	-	1,17	1,17	1,17	1,75	1,75	-	1,75	1,75	-	2,34	2,34	2,34
Fans rated current absorption	A	0	0	4,4	4,4	4,4	6,6	6,6	-	6,6	6,6	-	8,8	8,8	8,8
Standard pump rated power input	kW	-	-	1,36	1,36	1,36	1,82	1,82	-	1,82	1,82	-	1,82	1,82	1,82
Standard pump rated current absorption	A	-	-	2,5	2,5	2,5	3,4	3,4	-	3,4	3,4	-	3,4	3,4	3,4
Up-rated pump rated power input	kW	-	-	2,93	2,93	2,93	2,93	2,93	-	2,93	2,93	-	3,27	3,27	3,27
Up-rated pump rated current absorption	A	-	-	4,8	4,8	4,8	4,8	4,8	-	4,8	4,8	-	5,6	5,6	5,6
Standard AND pump rated power input	kW	-	-	2,6	2,6	2,6	2,72	2,72	-	2,72	2,72	-	2,72	2,72	2,72
Std. AND pump rated current absorp.	A	-	-	5,4	5,4	5,4	5	5	-	5	5	-	5	5	5
Up-rated AND pump rated power input	kW	-	-	2,6	2,6	2,6	3,52	3,52	-	3,52	3,52	-	5,86	5,86	5,86
Up-rated AND pump rated current absorp.	A	-	-	5,4	5,4	5,4	6,4	6,4	-	6,4	6,4	-	9,6	9,6	9,6
Auxiliary devices power supply	V	-	-	24	24	24	24	24	-	24	24	-	24	24	24

- The maximum electrical input is the mains electricity that must be available in order for the unit to work.
- The maximum current absorption refers to the current that will trigger the internal safety devices of the unit. It is the max current allowed in the unit.
- This value may never be exceeded; it must be used as a reference for determining the size of the power supply line and the related safety devices (refer to the wiring diagram supplied with the units).



# Technical Characteristics



**Tab.9- Rated technical/electrical data of LCE HS reversible heat pumps, STANDARD version, mod. 141-324**

Approx. capacity	kW	140			160			170	190	210	240	270	290	320
Efficiency pack	-	1	2	2	1	2	4	4	4	4	4	4	4	4
<b>LCE . . . HS</b>		<b>141</b>	<b>142</b>	<b>144</b>	<b>161</b>	<b>162</b>	<b>164</b>	<b>174</b>	<b>194</b>	<b>214</b>	<b>244</b>	<b>274</b>	<b>294</b>	<b>324</b>
Power supply	-	400 V / 3 Ph / 50 Hz												
Cooling capacity	kW	138,4	138,4	140,4	155,0	155,0	153,4	162,0	186,6	209,0	236,9	271,6	295,5	313,9
Total power input (cooling mode)	kW	48,2	48,2	47,8	58,6	58,6	56,0	56,8	70,7	83,3	92,9	104,2	112,8	120,2
Rated current input	A	92,5	92,3	87,1	103,9	103,9	111,1	115,8	135,6	152,3	172,7	195,2	204,7	210,8
EER	-	2,87	2,87	2,94	2,64	2,64	2,74	2,85	2,64	2,51	2,55	2,61	2,62	2,61
ESEER	-	3,93	4,18	4,10	3,61	3,87	3,75	4,16	4,04	4,00	4,01	4,10	4,12	4,18
Heating capacity	kW	153,3	153,3	150,2	179,8	179,8	176,2	188,3	212,4	235,6	272,5	307,2	329,8	350,8
Total power input (heating mode)	kW	46,8	46,8	46,3	55,6	55,6	55,0	55,6	65,2	73,0	85,1	95,9	104,2	112,6
Rated current input	A	90,2	89,7	84,2	96,8	96,8	106,2	118,1	135,3	147,3	170,7	191,0	201,9	206,0
COP	-	3,28	3,28	3,24	3,23	3,23	3,20	3,39	3,26	3,23	3,20	3,20	3,17	3,12
Maximum current input	A	131	131	129	137	144	150	136	155	173	196	224	237	251
Starting current	A	330	330	245	389	396	266	252	310	330	380	403	468	476
Scroll compressors / circuits	No.	2/2	2/1	4/2	2/2	2/1	4/2	4/2	4/2	4/2	4/2	4/2	4/2	4/2
Axial fans	No.	8	8	8	8	8	8	6	6	6	6	8	8	8
Air flow rate	m <sup>3</sup> /h	39890	39890	39890	39890	39890	39890	67672	67672	67672	75478	103511	97902	97902
Water flow rate (cooling)	l/h	23805	23805	24143	26660	26660	26378	27864	32095	35948	40747	46716	50827	53990
Pressure drop, water side (cooling)	kPa	49	49	50	42	42	43	46	49	50	53	41	49	55
Available head, std. pump (cooling)	kPa	150	150	147	147	147	148	155	133	147	171	170	152	137
Buffer tank	dm <sup>3</sup>	340	340	340	340	340	340	600	600	600	600	600	600	600
Expansion tank	dm <sup>3</sup>	12	12	12	12	12	12	24	24	24	24	24	24	24
Plumbing connections	"	21/2	21/2	21/2	21/2	21/2	21/2	3	3	3	4	4	4	4
Height	mm	1720	1720	1720	1720	1720	1720	1830	1830	1830	2174	2174	2174	2174
Length	mm	3190	3190	3540	3190	3190	3540	3540	3540	3540	3540	4296	4296	4296
Depth	mm	1185	1185	1185	1185	1185	1185	1654	1654	1654	1654	1654	1654	1654
Sound power level	dB(A)	82	82	82	82	82	82	83	83	83	83	84	84	84
Sound pressure level	dB(A)	54	54	54	54	54	54	55	55	55	55	56	56	56
Base unit operating weight	kg	1055	1055	1070	1085	1085	1220	1440	1460	1470	1620	1880	1912	1947
Unit with pump, full tank operating weight	kg	1626	1626	1661	1656	1656	1811	2208	2276	2286	2469	2894	2926	2961

- Cooling mode: outdoor air temperature 35°C, water temperature 12°C / 7°C.
- Heating mode: outdoor air temperature 7°C dry bulb and 6,2°C wet bulb, water temperature 40°C / 45°C.
- Sound power measured according to standards ISO 3741 - ISO 3744 and EN 29614-1.
- Sound pressure measured at a distance of 10 m and a height of 15 m above the ground in a clear field.

Approx. cooling output	kW	140			160			170	190	210	240	270	290	320
Efficiency pack	-	1	2	2	1	2	4	4	4	4	4	4	4	4
<b>LCE . . . HS</b>		<b>141</b>	<b>142</b>	<b>144</b>	<b>161</b>	<b>162</b>	<b>164</b>	<b>174</b>	<b>194</b>	<b>214</b>	<b>244</b>	<b>274</b>	<b>294</b>	<b>324</b>
Power supply	-	400 V / 3 Ph / 50 Hz												
Max. power input	kW	65,737	65,737	67,323	75,129	76,577	75,115	75,384	88,396	101,41	113,68	127,97	138,81	149,65
Max. current absorption	A	130,51	130,51	128,55	136,94	143,97	150,03	136,32	154,84	173,36	196,28	224	237,46	250,92
Start-up current	A	329,91	329,86	245,21	388,58	395,61	265,81	252,1	309,71	330,2	379,96	403,24	467,92	475,96
Start-up current with softstarter device	A	264,91	264,86	186,21	305,58	312,61	213,81	200,1	247,71	268,2	314,96	338,24	384,92	392,96
Fans	No.	8	8	8	8	8	8	6	6	6	6	8	8	8
Fans rated power input	kW	2,34	2,34	2,34	2,34	2,34	2,34	6,3	6,3	6,3	6,3	8,4	8,4	8,4
Fans rated current absorption	A	8,8	8,8	8,8	8,8	8,8	8,8	15	15	15	15	20	20	20
Standard pump rated power input	kW	2,93	2,93	2,93	2,93	2,93	2,93	2,8	2,8	3,7	5,1	5,1	5,1	5,1
Standard pump rated current absorption	A	4,8	4,8	4,8	4,8	4,8	4,8	4,8	4,8	6,8	9,2	9,2	9,2	9,2
Up-rated pump rated power input	kW	3,27	3,27	3,27	3,27	3,27	3,27	3,7	5,1	5,1	9,1	9,1	9,1	9,1
Up-rated pump rated current absorption	A	5,6	5,6	5,6	5,6	5,6	5,6	6,8	9,2	9,2	15,5	15,5	15,5	15,5
Standard AND pump rated power input	kW	2,72	2,72	2,72	2,72	2,72	2,72	4	4	4	5,6	5,6	5,6	5,6
Std. AND pump rated current absorp.	A	5	5	5	5	5	5	6,8	6,8	6,8	9,6	9,6	9,6	9,6
Up-rated AND pump rated power input	kW	5,86	5,86	5,86	5,86	5,86	5,86	5,6	5,6	5,6	7,4	7,4	7,4	7,4
Up-rated AND pump rated current absorp.	A	9,6	9,6	9,6	9,6	9,6	9,6	9,6	9,6	9,6	13,6	13,6	13,6	13,6
Auxiliary devices power supply	V	24	24	24	24	24	24	24	24	24	24	24	24	24

- The maximum electrical input is the mains electricity that must be available in order for the unit to work.
- The maximum current absorption refers to the current that will trigger the internal safety devices of the unit it is the max current allowed in the unit.
- This value may never be exceeded; it must be used as a reference for determining the size of the power supply line and the related safety devices (refer to the wiring diagram supplied with the units).

# Technical Characteristics



**Tab.10- Rated technical/electrical data of LCE HL reversible heat pumps, LOW NOISE version, mod. 042-124**

Approx. capacity	kW	45	50	60	70	80	90			100			120		
Efficiency pack	-	2	2	2	2	2	1	2	4	1	2	4	1	2	4
<b>LCE...HL</b>		<b>042</b>	<b>052</b>	<b>062</b>	<b>072</b>	<b>082</b>	<b>091</b>	<b>092</b>	<b>094</b>	<b>101</b>	<b>102</b>	<b>104</b>	<b>121</b>	<b>122</b>	<b>124</b>
Power supply	-	400 V / 3 Ph / 50 Hz													
Cooling capacity	kW	48,0	52,2	63,7	69,9	77,4	92,9	92,9	94,3	103,4	103,4	102,2	125,1	125,1	127,4
Total power input (cooling mode)	kW	16,2	18,6	22,0	24,7	28,2	32,0	32,0	32,3	38,4	38,4	37,1	44,4	44,4	44,2
Rated current input	A	32,5	35,3	42,4	45,1	56,2	62,7	62,7	64,7	71,2	71,2	70,2	81,2	81,2	80,5
EER	-	2,97	2,82	2,90	2,83	2,75	2,90	2,90	2,92	2,70	2,70	2,76	2,82	2,82	2,88
ESEER	-	4,06	4,04	4,05	4,01	3,98	3,45	4,00	3,90	3,40	3,95	3,85	3,88	4,22	4,09
Heating capacity	kW	53,3	61,0	71,1	78,8	86,8	104,9	104,9	102,8	118,3	118,3	115,9	139,9	139,9	137,1
Total power input (heating mode)	kW	15,5	18,3	20,1	22,7	26,0	30,6	30,6	30,3	35,4	35,4	35,0	44,0	44,0	43,6
Rated current input	A	31,8	33,8	42,3	43,6	54,3	61,3	61,3	62,9	67,9	67,9	67,0	79,9	79,6	78,8
COP	-	3,43	3,33	3,54	3,47	3,33	3,43	3,43	3,39	3,34	3,34	3,31	3,18	3,18	3,15
Maximum current input	A	41	44	51	55	66	77	77	81	86	86	87	95	95	96
Starting current	A	159	162	185	183	191	246	246	194	254	254	198	295	295	220
Scroll compressors / circuits	No.	2/1	2/1	2/1	2/1	2/1	2/1	2/1	4/2	2/2	2/1	4/2	2/2	2/1	4/2
Axial fans	No.	4	4	6	6	6	8	8	8	8	8	8	6	6	6
Air flow rate	m <sup>3</sup> /h	15398	15398	21955	21955	21955	29393	29393	29393	29393	29393	29393	43434	43434	43434
Water flow rate (cooling)	l/h	8261	8983	10956	12027	13313	15986	15986	16213	17778	17778	17582	21518	21518	21906
Pressure drop, water side (cooling)	kPa	27	31	47	35	43	32	32	33	39	39	38	40	40	41
Available head, std. pump (cooling)	kPa	157	149	125	131	117	129	129	128	118	118	119	107	107	105
Buffer tank	dm <sup>3</sup>	200	200	220	220	220	340	340	340	340	340	340	600	600	600
Expansion tank	dm <sup>3</sup>	12	12	12	12	12	12	12	12	12	12	12	24	24	24
Plumbing connections	"	2,00	2,00	2,00	2,00	2,00	2,50	2,50	2,50	2,50	2,50	2,50	3,00	3,00	3,00
Height	mm	1720	1720	1720	1720	1720	1720	1720	1720	1720	1720	1705	1830	1830	1830
Length	mm	2010	2010	2360	2360	2360	3190	3190	3540	3190	3190	3540	3540	3540	3540
Depth	mm	1185	1185	1185	1185	1185	1185	1185	1185	1185	1185	1185	1654	1654	1654
Sound power level	dB(A)	70	70	72	72	72	73	73	73	73	73	73	77	77	77
Sound pressure level	dB(A)	42	42	44	44	44	45	45	45	45	45	45	49	49	49
Base unit operating weight	kg	525	525	630	635	700	905	905	980	915	915	980	1260	1260	1275
Unit with pump, full tank op. weight	kg	862	862	982	987	1067	1426	1426	1557	1436	1436	1557	2040	2040	2055

- Cooling mode: outdoor air temperature 35°C, water temperature 12°C / 7°C.
- Heating mode: outdoor air temperature 7°C dry bulb and 6,2°C wet bulb, water temperature 40°C / 45°C.
- Sound power measured according to standards ISO 3741 - ISO 3744 and EN 29614-1.
- Sound pressure measured at a distance of 10 m and a height of 15 m above the ground in a clear field.

Approx. cooling output	kW	45	50	60	70	80	90			100			120		
Efficiency pack	-	2	2	2	2	2	1	2	4	1	2	4	1	2	4
<b>LCE...HL</b>		<b>042</b>	<b>052</b>	<b>062</b>	<b>072</b>	<b>082</b>	<b>091</b>	<b>092</b>	<b>094</b>	<b>101</b>	<b>102</b>	<b>104</b>	<b>121</b>	<b>122</b>	<b>124</b>
Power supply	-	400 V / 3 Ph / 50 Hz													
Max. power input	kW	22,067	24,535	28,499	31,893	35,789	42,67	42,67	44,134	49,176	49,176	49,07	56,21	56,21	57,144
Max. current absorption	A	40,564	43,524	51,086	55,206	65,946	76,868	76,868	81,128	86,128	86,128	87,048	95,02	95,02	96,28
Start-up current	A	159,37	161,67	185,49	182,69	190,69	246,05	246,05	194,25	254,25	254,25	198,45	294,68	295,38	220,48
Start-up curr. with softst. dev.	A	87,574	100,67	110,99	123,69	138,69	184,05	184,05	122,45	192,25	192,25	137,45	229,68	230,38	145,98
Fans	No.	4	4	6	6	6	8	8	8	8	8	8	6	6	6
Fans rated power input	kW	0,54	0,54	0,81	0,81	0,81	1,08	1,08	1,08	1,08	1,08	1,08	4,02	4,02	4,02
Fans rated current absorption	A	2,54	2,54	3,84	3,84	3,84	5,12	5,12	5,12	5,12	5,12	5,12	7,74	7,74	7,74
Std. pump rated power input	kW	1,36	1,36	1,36	1,36	1,36	1,82	1,82	1,82	1,82	1,82	1,82	1,82	1,82	1,82
Std. pump rated curr. absorp.	A	2,5	2,5	2,5	2,5	2,5	3,4	3,4	3,4	3,4	3,4	3,4	3,4	3,4	3,4
Uprat. pump rated power input	kW	1,76	1,76	2,93	2,93	2,93	2,93	2,93	2,93	2,93	2,93	2,93	3,27	3,27	3,27
Uprat. pump rat. curr. absorp.	A	3,2	3,2	4,8	4,8	4,8	4,8	4,8	4,8	4,8	4,8	4,8	5,6	5,6	5,6
Standard AND pump rated power input	kW	2,6	2,6	2,6	2,6	2,6	2,72	2,72	2,72	2,72	2,72	2,72	2,72	2,72	2,72
Std. AND pump rated current absorption	A	5,4	5,4	5,4	5,4	5,4	5	5	5	5	5	5	5	5	5
Uprat. AND pump rat. pow. inp	kW	2,6	2,6	2,6	2,6	2,6	3,52	3,52	3,52	3,52	3,52	3,52	5,86	5,86	5,86
Uprat. AND pump rated current absorp.	A	5,4	5,4	5,4	5,4	5,4	6,4	6,4	6,4	6,4	6,4	6,4	9,6	9,6	9,6
Auxiliary devices power supply	V	24	24	24	24	24	24	24	24	24	24	24	24	24	24

- The maximum electrical input is the mains electricity that must be available in order for the unit to work.
- The maximum current absorption refers to the current that will trigger the internal safety devices of the unit. It is the max current allowed in the unit.
- This value may never be exceeded; it must be used as a reference for determining the size of the power supply line and the related safety devices (refer to the wiring diagram supplied with the units).

# Technical Characteristics



**Tab.11- Rated technical/electrical data of LCE HL reversible heat pumps, LOW NOISE version, mod. 141-324**

Approx. capacity	kW	140			160			170	190	210	240	270	290	320
Efficiency pack	-	1	2	2	1	2	4	4	4	4	4	4	4	4
<b>LCE . . . HL</b>		<b>141</b>	<b>142</b>	<b>144</b>	<b>161</b>	<b>162</b>	<b>164</b>	<b>NA</b>	<b>194</b>	<b>214</b>	<b>244</b>	<b>274</b>	<b>294</b>	<b>324</b>
Power supply	-	400 V / 3 Ph / 50 Hz												
Cooling capacity	kW	137,5	137,5	139,8	155,4	155,4	153,7	-	181,2	211,9	230,3	265,3	287,4	304,4
Total power input (cooling mode)	kW	50,3	50,3	49,7	60,2	60,2	57,6	-	71,4	79,5	94,5	105,2	114,9	122,9
Rated current input	A	91,9	91,7	86,4	102,6	102,7	109,8	-	132,0	143,8	170,2	189,0	200,1	208,0
EER	-	2,74	2,74	2,81	2,58	2,58	2,67	-	2,54	2,67	2,44	2,52	2,50	2,48
ESEER	-	3,93	4,18	4,10	3,61	3,87	3,75	-	4,04	4,00	4,01	4,10	4,12	4,18
Heating capacity	kW	155,0	155,0	151,9	178,9	178,9	175,3	-	211,3	234,4	271,1	305,7	328,1	349,0
Total power input (heating mode)	kW	48,1	48,1	47,6	56,1	56,1	55,5	-	65,8	73,7	85,9	96,7	105,1	113,6
Rated current input	A	89,1	88,6	83,2	95,8	95,8	105,1	-	128,0	142,3	163,4	181,3	192,7	196,6
COP	-	3,22	3,22	3,19	3,19	3,19	3,16	-	3,21	3,18	3,16	3,16	3,12	3,07
Maximum current input	A	106	106	105	120	120	126	-	148	167	190	215	229	242
Starting current	A	306	306	222	371	371	241	-	307	318	382	398	464	472
Scroll compressors / circuits	No.	2/2	2/1	4/2	2/2	2/1	4/2	-	4/2	4/2	4/2	4/2	4/2	4/2
Axial fans	No.	6	6	6	6	6	6	-	6	6	6	8	8	8
Air flow rate	m <sup>3</sup> /h	43434	43434	43434	40235	40235	40235	-	55808	63261	63261	87186	81687	81687
Water flow rate (cooling)	l/h	23655	23655	24043	26719	26719	26434	-	31172	36451	36615	45628	49438	52350
Pressure drop, water side (cooling)	kPa	48	48	50	43	43	43	-	47	51	50	39	46	52
Available head, std. pump (cooling)	kPa	151	151	148	147	147	148	-	139	143	177	174	158	145
Buffer tank	dm <sup>3</sup>	600	600	600	600	600	600	-	600	600	600	600	600	600
Expansion tank	dm <sup>3</sup>	24	24	24	24	24	24	-	24	24	24	24	24	24
Plumbing connections	"	3	3	3	3	3	3	-	3	4	4	4	4	4
Height	mm	1830	1830	1830	1830	1830	1830	-	1830	2174	2174	2174	2174	2174
Length	mm	3540	3540	3540	3540	3540	3540	-	3540	3540	3540	4296	4296	4296
Depth	mm	1654	1654	1654	1654	1654	1654	-	1654	1654	1654	1654	1654	1654
Sound power level	dB(A)	77	77	77	77	77	77	-	77	77	78	79	79	79
Sound pressure level	dB(A)	49	49	49	49	49	49	-	49	49	50	51	51	51
Base unit operating weight	kg	1310	1310	1290	1330	1330	1440	-	1460	1510	1620	1880	1912	1947
Unit with pump, full tank operating weight	kg	2090	2090	2070	2110	2110	2220	-	2276	2326	2469	2894	2926	2961

- Cooling mode: outdoor air temperature 35°C, water temperature 12°C / 7°C.
- Heating mode: outdoor air temperature 7°C dry bulb and 6,2°C wet bulb, water temperature 40°C / 45°C.
- Sound power measured according to standards ISO 3741 - ISO 3744 and EN 29614-1.
- Sound pressure measured at a distance of 10 m and a height of 15 m above the ground in a clear field.

Approx. cooling output	kW	140			160			170	190	210	240	270	290	320
Efficiency pack	-	1	2	2	1	2	4	4	4	4	4	4	4	4
<b>LCE . . . HL</b>		<b>141</b>	<b>142</b>	<b>144</b>	<b>161</b>	<b>162</b>	<b>164</b>	<b>174</b>	<b>194</b>	<b>214</b>	<b>244</b>	<b>274</b>	<b>294</b>	<b>324</b>
Power supply	-	400 V / 3 Ph / 50 Hz												
Max. power input	kW	62,346	62,346	63,932	73,186	73,186	71,724	-	86,536	99,548	111,82	125,49	136,33	147,17
Max. current absorption	A	106,48	106,48	104,52	119,94	119,94	126	-	148,42	166,94	189,86	215,44	228,9	242,36
Start-up current	A	306,18	306,13	222,38	371,38	371,33	241,48	-	306,95	318,35	381,76	397,71	463,65	472,42
Start-up current with softstarter device	A	241,18	241,13	163,38	288,38	288,33	189,48	-	244,95	256,35	316,76	332,71	380,65	389,42
Fans	No.	6	6	6	6	6	6	-	6	6	6	8	8	8
Fans rated power input	kW	4,02	4,02	4,02	4,02	4,02	4,02	-	4,02	4,02	4,02	6,1	6,1	6,1
Fans rated current absorption	A	7,74	7,74	7,74	7,74	7,74	7,74	-	7,74	7,74	7,74	10,3	10,3	10,3
Standard pump rated power input	kW	2,93	2,93	2,93	2,93	2,93	2,93	-	2,8	3,7	5,1	5,1	5,1	5,1
Standard pump rated current absorption	A	4,8	4,8	4,8	4,8	4,8	4,8	-	4,8	6,8	9,2	9,2	9,2	9,2
Up-rated pump rated power input	kW	3,27	3,27	3,27	3,27	3,27	3,27	-	5,1	5,1	9,1	9,1	9,1	9,1
Up-rated pump rated current absorption	A	5,6	5,6	5,6	5,6	5,6	5,6	-	9,2	9,2	15,5	15,5	15,5	15,5
Standard AND pump rated power input	kW	2,72	2,72	2,72	2,72	2,72	2,72	-	4	4	5,6	5,6	5,6	5,6
Std. AND pump rated current absorp.	A	5	5	5	5	5	5	-	6,8	6,8	9,6	9,6	9,6	9,6
Up-rated AND pump rated power input	kW	5,86	5,86	5,86	5,86	5,86	5,86	-	5,6	5,6	7,4	7,4	7,4	7,4
Up-rated AND pump rated current absorp.	A	9,6	9,6	9,6	9,6	9,6	9,6	--	9,6	9,6	13,6	13,6	13,6	13,6
Auxiliary devices power supply	V	24	24	24	24	24	24	-	24	24	24	24	24	24

- The maximum electrical input is the mains electricity that must be available in order for the unit to work.
- The maximum current absorption refers to the current that will trigger the internal safety devices of the unit. It is the max current allowed in the unit.
- This value may never be exceeded; it must be used as a reference for determining the size of the power supply line and the related safety devices (refer to the wiring diagram supplied with the units).

# Technical Characteristics



**Tab.12- Rated technical/electrical data of LCE HQ reversible heat pumps, QUIET version, mod. 042-124**

Approx. capacity	kW	45	50	60	70	80	90			100			120		
Efficiency pack	-	2	2	2	2	2	1	2	4	1	2	4	1	2	4
<b>LCE . . . HQ</b>		<b>042</b>	<b>052</b>	<b>062</b>	<b>072</b>	<b>082</b>	<b>091</b>	<b>092</b>	<b>094</b>	<b>101</b>	<b>102</b>	<b>104</b>	<b>121</b>	<b>122</b>	<b>124</b>
Power supply	-	400 V / 3 Ph / 50 Hz													
Cooling capacity	kW	48,0	52,2	63,7	69,9	77,4	92,9	92,9	94,3	103,4	103,4	102,2	123,6	123,6	125,7
Total power input (cooling mode)	kW	16,2	18,6	22,0	24,7	28,2	32,0	32,0	32,3	38,4	35,4	37,1	45,0	38,4	45,0
Rated current input	A	32,6	35,3	42,4	45,1	56,2	62,7	62,7	64,7	71,2	71,2	70,2	82,0	82,0	81,6
EER	-	2,97	2,82	2,90	2,83	2,75	2,90	2,90	2,92	2,70	2,92	2,76	2,74	3,22	2,79
ESEER	-	4,06	4,04	4,05	4,01	3,98	3,45	4,00	3,90	3,40	3,95	3,85	3,88	4,22	4,09
Heating capacity	kW	53,3	61,0	71,1	78,8	86,8	104,9	104,9	102,8	118,3	118,3	115,9	136,2	136,2	133,5
Total power input (heating mode)	kW	15,5	18,3	20,1	22,7	26,0	30,6	30,6	30,3	35,4	35,4	35,0	42,7	42,7	42,3
Rated current input	A	31,8	33,8	42,3	43,1	54,3	61,3	61,3	62,8	67,8	67,8	67,0	79,9	79,6	79,1
COP	-	3,43	3,33	3,54	3,47	3,33	3,43	3,43	3,39	3,34	3,34	3,31	3,19	3,19	3,16
Maximum current input	A	41	44	51	55	66	77	77	81	86	86	87	99	99	100
Starting current	A	159	162	185	183	191	246	246	194	254	254	198	299	299	225
Scroll compressors / circuits	No.	2/1	2/1	2/1	2/1	2/1	2/2	2/1	4/2	2/2	2/1	4/2	2/2	2/1	4/2
Axial fans	No.	4	4	6	6	6	8	8	8	8	8	8	6	6	6
Air flow rate	m <sup>3</sup> /h	15398	15398	21955	21955	21955	29393	29393	29393	29393	29393	29393	35930	35930	35930
Water flow rate (cooling)	l/h	8261	8983	10956	12027	13313	15986	15986	16213	17778	17778	17582	21259	21259	21623
Pressure drop, water side (cooling)	kPa	27	31	47	35	43	32	32	33	39	39	38	39	39	40
Available head, std. pump (cooling)	kPa	157	149	125	131	117	129	129	128	118	118	119	109	109	106
Buffer tank	dm <sup>3</sup>	200	200	220	220	220	340	340	340	340	340	340	600	600	600
Expansion tank	dm <sup>3</sup>	12	12	12	12	12	12	12	12	12	12	12	24	24	24
Plumbing connections	"	2	2	2	2	2	2 1/2	2 1/2	2 1/2	2 1/2	2 1/2	2 1/2	3	3	3
Height	mm	1720	1720	1720	1720	1720	1720	1720	1720	1720	1720	1720	1830	1830	1830
Length	mm	2010	2010	2360	2360	2360	3190	3190	3540	3190	3190	3540	3540	3540	3540
Depth	mm	1185	1185	1185	1185	1185	1185	1185	1185	1185	1185	1185	1654	1654	1654
Sound power level	dB(A)	67	67	69	69	69	70	70	70	70	70	70	69	69	69
Sound pressure level	dB(A)	39	39	41	41	41	42	42	42	42	42	42	41	41	41
Base unit operating weight	kg	525	525	630	635	700	905	905	980	915	915	980	1260	1260	1275
Unit with pump, full tank op. weight	kg	862	862	982	987	1067	1426	1426	1557	1436	1436	1557	2040	2040	2055

- Cooling mode: outdoor air temperature 35°C, water temperature 12°C / 7°C.
- Heating mode: outdoor air temperature 7°C dry bulb and 6,2°C wet bulb, water temperature 40°C / 45°C.
- Sound power measured according to standards ISO 3741 - ISO 3744 and EN 29614-1.
- Sound pressure measured at a distance of 10 m and a height of 15 m above the ground in a clear field.

Approx. cooling output	kW	45	50	60	70	80	90			100			120		
Efficiency pack	-	2	2	2	2	2	1	2	4	1	2	4	1	2	4
<b>LCE . . . HQ</b>		<b>042</b>	<b>052</b>	<b>062</b>	<b>072</b>	<b>082</b>	<b>091</b>	<b>092</b>	<b>094</b>	<b>101</b>	<b>102</b>	<b>104</b>	<b>121</b>	<b>122</b>	<b>124</b>
Power supply	-	400 V / 3 Ph / 50 Hz													
Max. power input	kW	22,067	24,535	28,499	31,893	35,789	42,67	42,67	44,134	49,176	49,176	49,07	58,01	58,01	58,944
Max. current absorption	A	40,564	43,524	51,086	55,206	65,946	76,868	76,868	81,128	86,128	86,128	87,048	98,92	98,92	100,18
Start-up current	A	159,37	161,67	185,49	182,69	190,69	246,05	246,05	194,25	254,25	254,25	198,45	298,68	299,48	224,68
Start-up curr. with softst. dev.	A	87,574	100,67	110,99	123,69	138,69	184,05	184,05	122,45	192,25	192,25	137,45	233,68	234,48	150,18
Fans	No.	4	4	6	6	6	8	8	8	8	8	8	6	6	6
Fans rated power input	kW	0,54	0,54	0,81	0,81	0,81	1,08	1,08	1,08	1,08	1,08	1,08	4,02	4,02	4,02
Fans rated current absorption	A	2,56	2,56	3,84	3,84	3,84	5,12	5,12	5,12	5,12	5,12	5,12	7,74	7,74	7,74
Std. pump rated power input	kW	1,36	1,36	1,36	1,36	1,36	1,82	1,82	1,82	1,82	1,82	1,82	1,82	1,82	1,82
Std. pump rat. current absorp.	A	2,5	2,5	2,5	2,5	2,5	3,4	3,4	3,4	3,4	3,4	3,4	3,4	3,4	3,4
Uprat. pump rated power input	kW	1,76	1,76	2,93	2,93	2,93	2,93	2,93	2,93	2,93	2,93	2,93	3,27	3,27	3,27
Uprat. pump rated current absorption	A	3,2	3,2	4,8	4,8	4,8	4,8	4,8	4,8	4,8	4,8	4,8	5,6	5,6	5,6
Std. AND pump rat. power inp.	kW	2,6	2,6	2,6	2,6	2,6	2,72	2,72	2,72	2,72	2,72	2,72	2,72	2,72	2,72
Std. AND pump rated current absorp.	A	5,4	5,4	5,4	5,4	5,4	5	5	5	5	5	5	5	5	5
Uprat. AND pump rat. pow. inp.	kW	2,6	2,6	2,6	2,6	2,6	3,52	3,52	3,52	3,52	3,52	3,52	5,86	5,86	5,86
Uprat. AND pump rated current absorption	A	5,4	5,4	5,4	5,4	5,4	6,4	6,4	6,4	6,4	6,4	6,4	9,6	9,6	9,6
Auxiliary devices power supply	V	24	24	24	24	24	24	24	24	24	24	24	24	24	24

- The maximum electrical input is the mains electricity that must be available in order for the unit to work.
- The maximum current absorption refers to the current that will trigger the internal safety devices of the unit. It is the max current allowed in the unit.
- This value may never be exceeded; it must be used as a reference for determining the size of the power supply line and the related safety devices (refer to the wiring diagram supplied with the units).

# Technical Characteristics



**Tab.13- Rated technical/electrical data of LCE HQ reversible heat pumps, QUIET version, mod. 141-324**

Approx. capacity	kW	140			160			170	190	210	240	270	290	320
Efficiency pack	-	1	2	2	1	2	4	4	4	4	4	4	4	4
<b>LCE . . . HQ</b>		<b>141</b>	<b>142</b>	<b>144</b>	<b>161</b>	<b>162</b>	<b>164</b>	<b>NA</b>	<b>194</b>	<b>214</b>	<b>244</b>	<b>274</b>	<b>294</b>	<b>324</b>
Power supply	-	400 V / 3 Ph / 50 Hz												
Cooling capacity	kW	135,5	135,5	137,6	151,5	151,5	150,1	-	164,4	192,7	209,6	260,7	278,7	293,8
Total power input (cooling mode)	kW	51,1	51,1	50,8	62,0	62,0	59,4	-	81,1	90,8	98,7	105,6	117,3	126,1
Rated current input	A	92,9	92,8	87,9	105,2	105,2	112,0	-	144,2	158,2	173,5	190,5	203,8	212,6
EER	-	2,65	2,65	2,71	2,44	2,44	2,53	-	2,03	2,12	2,12	2,47	2,38	2,33
ESEER	-	3,93	4,18	4,10	3,61	3,87	3,75	-	4,04	4,00	4,01	4,10	4,12	4,18
Heating capacity	kW	151,2	151,2	148,2	174,1	174,1	170,6	-	205,7	228,1	263,9	297,5	319,3	339,7
Total power input (heating mode)	kW	47,4	47,4	46,9	55,0	55,0	54,5	-	64,5	72,2	84,2	94,8	103,1	111,4
Rated current input	A	89,1	88,6	83,5	95,8	95,8	105,1	-	128,0	142,5	150,4	181,0	189,7	193,6
COP	-	3,19	3,19	3,16	3,17	3,17	3,13	-	3,19	3,16	3,13	3,14	3,10	3,05
Maximum current input	A	110	110	108	124	124	130	-	148	167	190	213	226	240
Starting current	A	310	310	227	377	377	247	-	314	328	395	396	465	475
Scroll compressors / circuits	No.	2/2	2/1	4/2	2/2	2/1	4/2	-	4/2	4/2	4/2	4/2	4/2	4/2
Axial fans	No.	6	6	6	6	6	6	-	6	6	6	8	8	8
Air flow rate	m <sup>3</sup> /h	35930	35930	35930	35930	35930	35930	-	35930	40953	40953	69835	69835	69835
Water flow rate (cooling)	l/h	23303	23303	23667	26051	26051	25816	-	28282	33135	36054	44837	47938	50535
Pressure drop, water side (cooling)	kPa	47	47	48	41	41	40	-	39	39	42	38	44	48
Available head, std. pump (cooling)	kPa	153	153	151	151	151	152	-	161	171	193	177	164	153
Buffer tank	dm <sup>3</sup>	600	600	600	600	600	600	-	600	600	600	600	600	600
Expansion tank	dm <sup>3</sup>	24	24	24	24	24	24	-	24	24	24	24	24	24
Plumbing connections	"	3	3	3	3	3	3	-	3	4	4	4	4	4
Height	mm	1830	1830	1830	1830	1830	1830	-	1830	2174	2174	2174	2174	2174
Length	mm	3540	3540	3540	3540	3540	3540	-	3540	3540	3540	4296	4296	4296
Depth	mm	1654	1654	1654	1654	1654	1654	-	1654	1654	1654	1654	1654	1654
Sound power level	dB(A)	69	69	69	69	69	69	-	69	69	69	70	70	70
Sound pressure level	dB(A)	41	41	41	41	41	41	-	41	41	41	42	42	42
Base unit operating weight	kg	1310	1310	1290	1330	1330	1440	-	1460	1510	1620	1880	1912	1947
Unit with pump, full tank operating weight	kg	2090	2090	2070	2110	2110	2220	-	2276	2326	2469	2894	2926	2961

- Cooling mode: outdoor air temperature 35°C, water temperature 12°C / 7°C.
- Heating mode: outdoor air temperature 7°C dry bulb and 6,2°C wet bulb, water temperature 40°C / 45°C.
- Sound power measured according to standards ISO 3741 - ISO 3744 and EN 29614-1.
- Sound pressure measured at a distance of 10 m and a height of 15 m above the ground in a clear field.

Approx. cooling output	kW	140			160			170	190	210	240	270	290	320
Efficiency pack	-	1	2	2	1	2	4	4	4	4	4	4	4	4
<b>LCE . . . HQ</b>		<b>141</b>	<b>142</b>	<b>144</b>	<b>161</b>	<b>162</b>	<b>164</b>	<b>174</b>	<b>194</b>	<b>214</b>	<b>244</b>	<b>274</b>	<b>294</b>	<b>324</b>
Power supply	-	400 V / 3 Ph / 50 Hz												
Max. power input	kW	64,146	64,146	65,732	74,986	74,986	73,524	-	86,536	99,548	111,82	124,09	134,93	145,77
Max. current absorption	A	110,38	110,38	108,42	123,84	123,84	129,9	-	148,42	166,94	189,86	212,78	226,24	239,7
Start-up current	A	310,28	310,28	226,73	376,58	376,58	247,03	-	313,84	327,83	394,72	396,35	465,35	475,13
Start-up current with softstarter device	A	245,28	245,28	167,73	293,58	293,58	195,03	-	251,84	265,83	329,72	331,35	382,35	392,13
Fans	No.	6	6	6	6	6	6	-	6	6	6	8	8	8
Fans rated power input	kW	4,02	4,02	4,02	4,02	4,02	4,02	-	4,02	4,02	4,02	4	4	4
Fans rated current absorption	A	7,74	7,74	7,74	7,74	7,74	7,74	-	7,74	7,74	7,74	7,2	7,2	7,2
Standard pump rated power input	kW	2,93	2,93	2,93	2,93	2,93	2,93	-	2,8	3,7	5,1	5,1	5,1	5,1
Standard pump rated current absorption	A	4,8	4,8	4,8	4,8	4,8	4,8	-	4,8	6,8	9,2	9,2	9,2	9,2
Up-rated pump rated power input	kW	3,27	3,27	3,27	3,27	3,27	3,27	-	5,1	5,1	9,1	9,1	9,1	9,1
Up-rated pump rated current absorption	A	5,6	5,6	5,6	5,6	5,6	5,6	-	9,2	9,2	15,5	15,5	15,5	15,5
Standard AND pump rated power input	kW	2,72	2,72	2,72	2,72	2,72	2,72	-	4	4	5,6	5,6	5,6	5,6
Std. AND pump rated current absorp.	A	5	5	5	5	5	5	-	6,8	6,8	9,6	9,6	9,6	9,6
Up-rated AND pump rated power input	kW	5,86	5,86	5,86	5,86	5,86	5,86	-	5,6	5,6	7,4	7,4	7,4	7,4
Up-rated AND pump rated current absorp.	A	9,6	9,6	9,6	9,6	9,6	9,6	-	9,6	9,6	13,6	13,6	13,6	13,6
Auxiliary devices power supply	V	24	24	24	24	24	24	-	24	24	24	24	24	24

- The maximum electrical input is the mains electricity that must be available in order for the unit to work.
- The maximum current absorption refers to the current that will trigger the internal safety devices of the unit. It is the max current allowed in the unit.
- This value may never be exceeded; it must be used as a reference for determining the size of the power supply line and the related safety devices (refer to the wiring diagram supplied with the units).

## Performance

Tbs<sub>1</sub> Air inlet temperature (dry bulb)  
 Tw<sub>1/2</sub> Water inlet/outlet temperature  
 PF Cooling capacity  
 PA Total power input including pump

**Tab.14- Cooling capacities of LCE CS water chillers, STANDARD version**

LCE ... CS	Tbs <sub>1</sub> (°C)		25		30		35		40		45	
	Tw <sub>1</sub>	Tw <sub>2</sub>	PF	PA	PF	PA	PF	PA	PF	PA	PF	PA
	°C		kW		kW		kW		kW		kW	
062	10	5	67,8	18,1	63,3	20,3	59,5	22,2	55,4	24,4	51,0	26,9
	12	7	72,6	18,2	67,2	20,7	63,3	22,6	58,8	24,8	54,3	27,2
	14	9	77,6	18,2	71,4	21,0	67,0	23,0	62,5	25,2	57,7	27,6
	15	10	80,1	18,2	73,4	21,1	69,0	23,2	64,4	25,4	59,4	27,8
	17	12	82,1	19,7	77,8	21,5	73,1	23,5	68,2	25,7	63,0	28,1
072	10	5	76,6	19,4	69,7	22,7	65,3	25,0	60,2	27,6	55,0	30,6
	12	7	81,9	19,5	74,0	23,0	69,2	25,4	64,0	28,0	58,5	30,9
	14	9	83,4	21,3	78,5	23,4	73,3	25,8	67,9	28,4	62,2	31,2
	15	10	85,8	21,5	80,9	23,6	75,4	26,0	69,9	28,6	64,0	31,4
	17	12	90,6	22,0	85,4	24,1	79,9	26,4	73,8	29,1	67,8	31,7
082	10	5	82,0	23,5	77,2	25,9	72,0	28,5	66,3	31,6	60,6	34,7
	12	7	87,1	23,9	82,0	26,3	76,5	29,0	70,5	32,0	64,7	34,9
	14	9	92,5	24,4	87,1	26,7	81,3	29,4	75,0	32,4	69,0	35,3
	15	10	95,2	24,5	89,6	26,9	83,6	29,7	77,3	32,6	71,1	35,5
	17	12	100,9	25,0	94,8	27,4	88,6	30,1	81,9	33,1	75,5	35,8
091	10	5	100,7	25,5	92,4	29,6	86,6	32,7	80,3	36,2	73,5	40,0
	12	7	108,1	25,5	98,3	30,0	92,2	33,1	85,4	36,6	78,4	40,4
	14	9	110,6	27,6	104,3	30,4	97,8	33,5	90,8	37,0	83,5	40,8
	15	10	114,0	27,8	107,5	30,6	100,8	33,8	93,5	37,3	86,0	41,0
	17	12	120,7	28,3	114,0	31,1	106,8	34,3	99,3	37,8	91,3	41,4
092	10	5	100,7	25,5	92,4	29,6	86,6	32,7	80,3	36,2	73,5	40,0
	12	7	108,1	25,5	98,3	30,0	92,2	33,1	85,4	36,6	78,4	40,4
	14	9	110,6	27,6	104,3	30,4	97,8	33,5	90,8	37,0	83,5	40,8
	15	10	114,0	27,8	107,5	30,6	100,8	33,8	93,5	37,3	86,0	41,0
	17	12	120,7	28,3	114,0	31,1	106,8	34,3	99,3	37,8	91,3	41,4
101	10	5	109,9	31,7	103,5	35,1	96,6	38,9	89,2	43,1	81,6	47,5
	12	7	116,8	32,2	109,7	35,7	102,7	39,5	94,9	43,7	86,9	48,0
	14	9	123,6	32,8	116,4	36,2	108,9	40,1	100,5	44,4	92,4	48,6
	15	10	127,4	33,1	119,7	36,6	111,9	40,4	103,5	44,7	95,0	48,9
	17	12	134,5	33,8	126,7	37,2	118,2	41,1	109,5	45,4	100,8	49,5
102	10	5	109,7	31,7	103,4	35,1	96,7	38,9	89,4	43,1	81,6	47,5
	12	7	116,7	32,2	109,7	35,7	102,8	39,5	94,9	43,7	86,9	48,0
	14	9	123,5	32,8	116,4	36,2	108,9	40,1	100,5	44,4	92,4	48,6
	15	10	127,4	33,1	119,7	36,6	111,8	40,4	103,5	44,7	95,0	48,9
	17	12	134,6	33,8	126,7	37,2	118,2	41,0	109,5	45,4	100,8	49,5

LCE ... CS	Tbs <sub>1</sub> (°C)		25		30		35		40		45	
	Tw <sub>1</sub>	Tw <sub>2</sub>	PF	PA	PF	PA	PF	PA	PF	PA	PF	PA
	°C		kW		kW		kW		kW		kW	
121	10	5	134,8	33,8	124,7	38,6	116,9	42,5	108,4	46,9	99,3	51,8
	12	7	144,5	33,8	132,5	39,2	124,1	43,1	115,2	47,5	105,8	52,3
	14	9	154,5	33,8	140,5	39,7	131,8	43,7	122,3	48,1	112,5	52,8
	15	10	153,2	36,5	144,5	40,0	135,8	44,0	126,0	48,4	115,6	53,2
	17	12	162,0	37,1	153,4	40,6	143,7	44,6	133,5	49,0	122,9	53,7
122	10	5	134,8	33,8	124,7	38,6	116,9	42,5	108,4	46,9	99,3	51,8
	12	7	144,5	33,8	132,5	39,2	124,1	43,1	115,2	47,5	105,9	52,3
	14	9	154,5	33,8	140,5	39,7	131,8	43,7	122,3	48,1	112,5	52,8
	15	10	153,2	36,5	144,5	40,0	135,8	44,0	126,0	48,4	115,6	53,2
	17	12	162,0	37,1	153,4	40,6	143,7	44,6	133,5	49,0	122,9	53,7
124	10	5	137,0	34,0	126,9	38,6	119,3	42,3	110,9	46,4	101,9	51,1
	12	7	146,6	34,1	134,6	39,2	126,4	43,0	117,8	47,1	108,5	51,7
	14	9	156,5	34,1	142,7	39,9	134,1	43,6	124,9	47,8	115,2	52,3
	15	10	155,3	36,8	146,6	40,2	138,1	44,0	128,6	48,2	118,6	52,7
	17	12	164,1	37,4	155,5	40,9	146,0	44,6	135,9	49,0	125,7	53,4
141	10	5	151,5	37,7	139,1	43,4	130,1	47,5	120,6	52,3	110,2	57,4
	12	7	162,4	37,7	147,7	44,0	138,4	48,2	128,1	52,9	117,2	58,0
	14	9	165,7	40,8	156,7	44,6	146,4	48,9	135,7	53,7	124,7	58,6
	15	10	170,9	41,1	161,1	45,0	150,8	49,3	139,7	54,0	128,2	59,0
	17	12	180,7	41,7	170,6	45,6	159,5	50,0	148,0	54,7	136,0	59,5
142	10	5	151,5	37,7	139,1	43,4	130,1	47,5	120,6	52,3	110,2	57,4
	12	7	162,4	37,7	147,7	44,0	138,4	48,2	128,1	52,9	117,2	58,0
	14	9	165,7	40,8	156,7	44,6	146,4	48,9	135,7	53,7	124,7	58,6
	15	10	170,9	41,1	161,1	45,0	150,8	49,3	139,7	54,0	128,2	59,0
	17	12	180,7	41,7	170,6	45,6	159,5	50,0	148,0	54,7	136,0	59,5
144	10	5	154,5	36,7	141,3	42,6	132,1	47,0	122,3	52,1	111,8	57,6
	12	7	165,2	36,8	150,0	43,3	140,4	47,8	129,9	52,8	118,8	58,2
	14	9	168,8	40,0	159,0	44,0	148,7	48,4	137,8	53,5	126,4	58,8
	15	10	173,3	40,5	163,8	44,4	153,1	48,8	141,5	53,9	129,9	59,2
	17	12	183,9	41,2	173,4	45,1	161,9	49,6	149,9	54,7	137,7	59,8
161	10	5	166,4	47,9	156,6	52,5	146,7	57,7	135,4	63,4	123,2	69,2
	12	7	176,8	48,8	166,4	53,4	155,4	58,6	143,2	64,3	130,9	70,0
	14	9	187,1	49,7	176,3	54,4	164,0	59,6	151,2	65,3	138,6	70,8
	15	10	192,6	50,3	180,8	55,0	168,3	60,1	155,5	65,8	142,6	71,2
	17	12	203,7	51,2	191,0	55,9	177,4	61,2	163,9	66,9	150,9	72,2
162	10	5	166,9	47,9	156,9	52,5	146,3	57,5	135,0	63,3	123,2	69,2
	12	7	176,9	48,8	166,4	53,4	155,0	58,6	143,0	64,3	130,9	70,0
	14	9	187,2	49,7	176,3	54,4	164,0	59,6	151,2	65,3	138,6	70,8
	15	10	192,5	50,3	180,8	55,0	168,5	60,1	155,5	65,8	142,6	71,2
	17	12	203,3	51,2	190,8	56,0	177,9	61,2	163,9	66,9	150,9	72,2

LCE ... CS	Tbs <sub>1</sub> (°C)		25		30		35		40		45	
	Tw <sub>1</sub>	Tw <sub>2</sub>	PF	PA	PF	PA	PF	PA	PF	PA	PF	PA
	°C		kW		kW		kW		kW		kW	
164	10	5	164,2	45,5	154,6	50,1	144,2	55,3	133,2	61,0	121,6	67,2
	12	7	174,5	46,2	164,2	50,9	153,4	56,0	141,5	61,9	129,8	67,7
	14	9	185,2	47,0	174,5	51,6	162,9	56,8	150,4	62,8	138,0	68,4
	15	10	190,8	47,5	179,2	52,1	167,6	57,4	154,7	63,2	142,4	68,8
	17	12	201,6	48,3	190,1	53,0	177,2	58,4	163,8	64,1	151,1	69,5
174	10	5	169,2	47,8	161,6	51,4	152,0	56,3	141,9	61,8	130,8	68,0
	12	7	181,3	47,8	172,3	52,0	162,0	56,8	151,6	62,3	139,8	68,5
	14	9	194,1	47,7	183,1	52,5	172,5	57,4	161,3	62,8	149,1	69,0
	15	10	201,2	47,7	189,2	52,7	178,2	57,7	166,3	63,2	153,8	69,3
	17	12	215,1	47,7	201,2	53,3	189,4	58,3	177,1	63,8	163,8	69,9
194	10	5	199,8	56,7	186,7	63,7	174,9	70,1	162,9	77,3	149,4	85,4
	12	7	214,0	56,7	198,4	64,4	186,6	70,7	173,4	78,0	159,4	86,2
	14	9	229,0	56,7	211,1	65,2	198,0	71,7	184,4	78,9	170,0	86,9
	15	10	237,3	56,7	217,6	65,6	204,1	72,0	190,0	79,4	175,3	87,4
	17	12	253,4	56,7	230,2	66,6	216,7	73,1	201,6	80,4	186,2	88,2
214	10	5	230,4	63,5	209,8	74,3	196,9	82,1	182,6	90,8	166,7	100,3
	12	7	247,1	63,5	223,1	75,4	209,0	83,3	193,8	91,9	177,5	101,4
	14	9	250,9	69,6	236,9	76,5	221,4	84,5	205,6	93,1	188,7	102,5
	15	10	258,3	70,1	243,7	77,1	228,5	84,9	211,7	93,8	195,0	102,9
	17	12	274,0	71,2	257,7	78,4	241,6	86,2	223,8	95,2	206,5	104,2
244	10	5	255,1	74,1	237,8	83,3	223,5	91,7	207,5	101,0	189,9	111,4
	12	7	273,0	74,1	252,6	84,5	237,0	92,9	220,6	102,2	201,9	112,8
	14	9	292,4	74,1	267,8	85,8	251,5	94,1	233,7	103,7	214,5	114,0
	15	10	302,2	74,1	276,0	86,4	259,1	94,8	240,1	104,5	221,0	114,7
	17	12	308,4	80,1	292,4	87,7	274,0	96,3	254,6	105,7	234,5	115,9
274	10	5	294,3	83,3	272,5	94,2	255,4	103,0	236,5	112,9	216,9	123,7
	12	7	314,9	83,3	289,5	95,5	271,6	104,2	252,0	114,0	231,2	124,7
	14	9	337,2	83,3	307,0	96,6	288,5	105,4	267,5	115,3	245,6	126,0
	15	10	348,4	83,3	316,3	97,2	296,5	106,2	275,4	116,1	253,0	126,5
	17	12	354,8	90,3	335,0	98,6	314,4	107,4	291,9	117,5	269,0	127,8
294	10	5	318,7	90,9	295,4	101,9	277,9	111,4	259,1	122,1	237,2	133,9
	12	7	340,6	90,9	314,7	103,1	295,5	112,8	274,8	123,7	252,0	135,6
	14	9	364,4	91,0	334,2	104,7	313,7	114,2	291,5	125,1	267,6	136,8
	15	10	376,4	91,0	343,8	105,4	323,0	115,1	299,6	125,9	275,6	137,7
	17	12	385,7	98,0	364,0	107,0	341,4	116,8	317,1	127,5	292,1	139,1
324	10	5	343,3	94,9	315,7	108,2	296,1	118,3	274,6	129,8	251,4	142,4
	12	7	367,1	95,1	335,7	109,9	313,9	120,2	290,9	131,5	266,9	144,0
	14	9	392,2	95,2	355,1	111,6	333,1	121,8	309,1	133,3	283,8	145,7
	15	10	387,4	103,2	365,8	112,5	342,2	122,8	317,4	134,4	292,2	146,3
	17	12	409,4	104,8	387,0	114,3	362,5	124,8	336,1	136,2	308,7	148,3



# Performance



Tbs<sub>1</sub> Air inlet temperature (dry bulb)  
 Tw<sub>1/2</sub> Water inlet/outlet temperature  
 PF Cooling capacity  
 PA Total power input including pump

**Tab.15- Cooling capacities of LCE CL water chillers, LOW NOISE version**

LCE . . . CL	Tbs <sub>1</sub> (°C)		25		30		35		40		45	
	Tw <sub>1</sub>	Tw <sub>2</sub>	PF	PA	PF	PA	PF	PA	PF	PA	PF	PA
	°C		kW		kW		kW		kW		kW	
042	10	5	51,4	13,0	48,0	14,6	45,2	15,9	42,1	17,5	38,9	19,2
	12	7	55,1	13,1	51,1	14,8	48,0	16,2	44,8	17,7	41,3	19,5
	14	9	59,1	13,2	54,2	15,1	51,0	16,5	47,5	18,0	43,8	19,7
	15	10	61,1	13,2	55,9	15,3	52,4	16,6	48,8	18,2	45,0	19,9
	17	12	62,5	14,3	59,1	15,6	55,6	16,9	51,6	18,5	47,7	20,1
052	10	5	57,2	14,3	52,4	16,6	49,2	18,2	45,7	20,0	41,8	22,1
	12	7	61,7	14,3	55,8	16,9	52,3	18,5	48,4	20,4	44,4	22,3
	14	9	62,8	15,8	59,3	17,2	55,3	18,9	51,3	20,7	47,3	22,6
	15	10	64,9	15,9	61,0	17,4	56,9	19,1	52,8	20,9	48,6	22,8
	17	12	68,7	16,2	64,5	17,7	60,2	19,4	55,9	21,2	51,5	23,1
062	10	5	67,8	17,8	63,7	19,8	59,9	21,7	55,9	23,8	51,6	26,2
	12	7	72,6	17,8	67,7	20,1	63,7	22,0	59,5	24,1	54,8	26,6
	14	9	77,6	17,9	71,9	20,4	67,7	22,3	63,1	24,5	58,3	26,9
	15	10	80,1	17,9	74,0	20,5	69,7	22,5	64,9	24,7	60,0	27,1
	17	12	85,5	17,9	78,3	20,9	73,8	22,9	68,9	25,1	63,7	27,5
072	10	5	76,6	19,1	70,5	22,0	65,8	24,3	60,9	26,9	55,7	29,8
	12	7	81,9	19,1	74,8	22,3	69,9	24,7	64,7	27,3	59,2	30,2
	14	9	87,7	19,2	79,2	22,7	74,2	25,0	68,7	27,6	62,9	30,5
	15	10	86,6	20,9	81,6	22,9	76,4	25,2	70,6	27,9	64,9	30,6
	17	12	91,7	21,2	86,4	23,4	80,8	25,6	74,9	28,2	68,7	31,0
082	10	5	86,5	21,1	77,9	25,1	72,8	27,8	67,3	30,7	61,4	33,9
	12	7	88,0	23,2	82,7	25,6	77,4	28,2	71,6	31,1	65,6	34,2
	14	9	93,4	23,6	88,1	25,9	82,2	28,6	76,0	31,5	69,7	34,5
	15	10	96,3	23,7	90,5	26,2	84,7	28,8	78,3	31,8	72,1	34,6
	17	12	101,8	24,2	95,9	26,6	89,8	29,3	83,1	32,2	76,6	35,0
091	10	5	100,7	27,0	93,3	28,5	87,3	31,6	81,1	35,1	74,3	38,9
	12	7	108,1	24,8	99,1	28,9	92,9	32,0	86,2	35,5	79,2	39,3
	14	9	115,6	24,8	105,3	29,4	98,6	32,5	91,6	36,0	84,2	39,7
	15	10	119,5	24,8	108,3	29,6	101,6	32,7	94,2	36,2	86,8	40,0
	17	12	121,4	27,3	114,8	30,1	107,6	33,2	100,0	36,7	92,2	40,4
092	10	5	100,7	24,8	93,3	28,5	87,3	31,6	81,1	35,1	74,3	38,9
	12	7	108,1	24,8	99,1	28,9	92,9	32,0	86,2	35,5	79,2	39,3
	14	9	115,6	24,8	105,3	29,4	98,6	32,5	91,6	36,0	84,2	39,7
	15	10	119,5	24,8	108,3	29,6	101,6	32,7	94,2	36,2	86,8	40,0
	17	12	121,4	27,3	114,8	30,1	107,6	33,2	100,0	36,7	92,2	40,4

LCE ... CL	Tbs <sub>i</sub> (°C)		25		30		35		40		45	
	Tw <sub>1</sub>	Tw <sub>2</sub>	PF	PA	PF	PA	PF	PA	PF	PA	PF	PA
	°C		kW		kW		kW		kW		kW	
094	10	5	101,6	25,6	94,3	29,1	88,7	31,8	82,7	34,9	76,3	38,4
	12	7	108,9	25,7	100,2	29,6	94,3	32,3	87,8	35,5	81,0	38,9
	14	9	116,6	25,9	106,3	30,1	99,8	32,9	93,0	36,0	85,9	39,4
	15	10	115,6	28,0	109,3	30,5	102,8	33,3	95,6	36,4	88,2	39,7
	17	12	122,4	28,6	115,8	31,1	108,6	33,9	101,0	37,0	93,4	40,2
101	10	5	115,6	28,2	104,2	34,0	97,4	37,8	89,9	42,0	82,4	46,4
	12	7	117,6	31,1	110,7	34,5	103,4	38,4	95,6	42,5	87,5	47,0
	14	9	124,6	31,7	117,3	35,2	109,6	39,0	101,5	43,2	93,1	47,5
	15	10	128,0	32,0	120,8	35,4	112,9	39,3	104,3	43,6	96,0	47,8
	17	12	135,6	32,7	127,7	36,1	119,2	40,0	110,6	44,2	101,6	48,4
102	10	5	115,7	28,2	104,1	34,0	97,5	37,8	90,1	42,0	82,4	46,4
	12	7	117,4	31,1	110,7	34,5	103,5	38,4	95,7	42,5	87,5	47,0
	14	9	124,6	31,7	117,2	35,2	109,6	39,0	101,5	43,2	93,1	47,5
	15	10	128,0	32,0	120,8	35,4	112,8	39,3	104,3	43,6	96,0	47,8
	17	12	135,8	32,7	127,7	36,1	119,0	40,0	110,6	44,2	101,6	48,4
104	10	5	112,8	28,1	102,6	33,1	96,4	36,4	89,2	40,1	81,7	44,0
	12	7	115,7	30,8	109,0	33,8	102,2	37,1	94,6	40,8	86,9	44,6
	14	9	122,8	31,5	115,8	34,4	108,2	37,7	100,3	41,5	92,1	45,2
	15	10	126,6	31,8	119,1	34,8	111,4	38,1	103,0	41,8	94,8	45,6
	17	12	134,2	32,5	125,8	35,5	117,4	38,8	109,1	42,6	100,6	46,1
121	10	5	134,8	35,5	125,4	40,0	117,6	43,9	109,4	48,1	100,1	52,9
	12	7	144,5	35,5	133,4	40,5	125,1	44,4	116,3	48,7	106,7	53,5
	14	9	154,5	35,5	141,5	41,0	132,9	44,9	123,5	49,2	113,4	54,0
	15	10	160,0	35,5	145,8	41,2	136,6	45,2	126,9	49,6	116,8	54,4
	17	12	163,2	38,3	154,4	41,8	144,9	45,7	134,8	50,2	123,9	54,9
122	10	5	134,8	35,5	125,4	40,0	117,6	43,9	109,4	48,1	100,1	52,9
	12	7	144,5	35,5	133,4	40,5	125,1	44,4	116,3	48,7	106,7	53,5
	14	9	154,5	35,5	141,5	41,0	132,9	44,9	123,5	49,2	113,4	54,0
	15	10	160,0	35,5	145,8	41,2	136,6	45,2	126,9	49,6	116,8	54,4
	17	12	163,2	38,3	154,4	41,8	144,9	45,7	134,8	50,2	123,9	54,9
124	10	5	136,9	35,6	127,5	39,9	119,9	43,5	111,9	47,5	102,9	52,2
	12	7	146,6	35,7	135,5	40,5	127,4	44,2	118,8	48,2	109,3	52,9
	14	9	156,4	35,7	143,8	41,0	135,1	44,8	126,0	48,9	116,2	53,4
	15	10	161,9	35,8	147,8	41,4	138,9	45,2	129,4	49,3	119,7	53,8
	17	12	165,0	38,7	156,4	42,0	147,1	45,8	137,3	50,0	126,8	54,5
141	10	5	151,5	39,4	138,6	45,3	129,6	49,6	120,0	54,2	109,6	59,3
	12	7	162,4	39,3	146,9	46,0	137,5	50,3	127,2	55,0	116,5	60,1
	14	9	165,0	42,8	156,1	46,6	146,1	50,9	135,0	55,7	124,1	60,5
	15	10	170,0	43,0	160,3	47,0	150,1	51,2	139,0	56,0	127,6	60,9
	17	12	179,9	43,7	169,7	47,7	158,8	51,9	147,3	56,7	135,6	61,5

LCE ... CL	Tbs <sub>i</sub> (°C)		25		30		35		40		45	
	Tw <sub>1</sub>	Tw <sub>2</sub>	PF	PA	PF	PA	PF	PA	PF	PA	PF	PA
	°C		kW		kW		kW		kW		kW	
142	10	5	151,5	39,4	138,6	45,3	129,6	49,6	120,0	54,2	109,6	59,3
	12	7	162,4	39,3	146,9	46,0	137,5	50,3	127,2	55,0	116,5	60,1
	14	9	165,0	42,8	156,1	46,6	146,1	50,9	135,0	55,7	124,1	60,5
	15	10	170,0	43,0	160,3	47,0	150,1	51,2	139,0	56,0	127,6	60,9
	17	12	179,9	43,7	169,7	47,7	158,8	51,9	147,3	56,7	135,6	61,5
144	10	5	154,5	38,4	140,9	44,6	131,6	49,1	121,7	54,1	111,1	59,7
	12	7	165,3	38,5	149,2	45,3	139,8	49,7	129,2	54,7	118,4	60,2
	14	9	167,7	42,1	158,5	46,0	148,1	50,5	136,8	55,6	125,4	60,9
	15	10	172,8	42,5	162,9	46,4	152,1	50,9	140,8	56,0	129,2	61,1
	17	12	182,7	43,3	172,4	47,1	160,9	51,7	149,1	56,7	136,9	61,9
161	10	5	166,3	49,5	156,9	54,1	147,0	59,2	135,8	64,9	123,3	70,8
	12	7	176,7	50,4	166,7	54,9	155,7	60,2	143,2	65,9	130,9	71,5
	14	9	187,4	51,3	176,3	55,9	164,4	61,1	151,6	66,8	138,8	72,5
	15	10	193,0	51,8	181,1	56,5	168,7	61,6	155,9	67,3	142,9	72,8
	17	12	204,0	52,8	191,4	57,4	177,9	62,6	164,3	68,5	151,3	73,7
162	10	5	167,2	49,5	157,2	54,1	146,7	59,1	135,1	64,9	123,3	70,8
	12	7	177,2	50,4	166,7	54,9	155,4	60,2	143,4	65,8	130,9	71,5
	14	9	187,5	51,3	176,3	55,9	164,4	61,1	151,6	66,8	138,8	72,5
	15	10	192,8	51,8	181,1	56,5	168,9	61,6	155,9	67,3	142,9	72,8
	17	12	203,7	52,8	191,2	57,5	178,0	62,8	164,3	68,5	151,3	73,7
164	10	5	164,5	47,0	154,9	51,6	144,5	56,8	133,1	62,7	121,9	68,7
	12	7	174,8	47,8	164,5	52,4	153,7	57,6	141,9	63,4	129,9	69,3
	14	9	185,5	48,6	174,8	53,2	162,8	58,5	150,6	64,2	138,4	69,9
	15	10	191,1	49,0	179,6	53,7	167,9	58,9	154,9	64,8	142,8	70,3
	17	12	202,0	49,8	190,5	54,6	177,6	59,9	164,2	65,6	151,5	71,0
194	10	5	200,0	54,4	182,3	63,7	170,6	70,5	158,2	77,9	144,4	86,1
	12	7	214,2	54,4	193,8	64,6	181,2	71,4	168,0	79,0	153,9	87,0
	14	9	217,9	59,6	205,4	65,7	192,7	72,4	178,5	79,9	163,9	87,8
	15	10	224,7	60,1	211,7	66,2	198,2	72,9	183,6	80,5	169,0	88,3
	17	12	237,9	61,1	224,4	67,2	209,9	74,0	194,8	81,7	179,5	89,2
214	10	5	228,2	62,2	212,0	70,7	199,3	78,4	185,5	87,1	170,1	96,7
	12	7	244,7	62,2	225,6	71,8	211,9	79,5	197,0	88,2	180,7	97,9
	14	9	261,6	62,2	239,6	72,9	224,7	80,7	208,5	89,5	191,9	99,1
	15	10	270,3	62,2	246,4	73,5	231,0	81,3	214,6	90,2	197,8	99,8
	17	12	276,3	67,8	260,9	74,8	244,6	82,7	227,1	91,5	209,7	101,0
244	10	5	255,1	71,8	232,4	84,3	217,0	93,0	200,7	102,7	183,4	113,2
	12	7	261,3	77,9	246,4	85,7	230,3	94,4	212,8	104,2	195,1	114,4
	14	9	276,3	79,2	260,8	87,2	243,8	96,0	225,3	105,8	206,8	115,9
	15	10	284,4	80,0	268,2	87,9	250,9	96,8	232,1	106,6	213,1	116,6
	17	12	300,8	81,4	283,5	89,4	265,2	98,4	244,8	108,5	225,6	118,0

LCE ... CL	Tbs <sub>i</sub> (°C)		25		30		35		40		45	
	Tw <sub>1</sub>	Tw <sub>2</sub>	PF	PA	PF	PA	PF	PA	PF	PA	PF	PA
	°C		kW		kW		kW		kW		kW	
274	10	5	294,1	81,2	267,2	94,8	249,5	103,9	230,7	113,9	211,0	124,7
	12	7	300,4	88,0	283,7	96,1	265,3	105,2	245,1	115,3	224,4	126,0
	14	9	318,2	89,3	300,9	97,5	281,1	106,7	260,1	116,7	238,4	127,3
	15	10	328,0	89,9	309,4	98,2	289,5	107,5	267,8	117,5	246,2	127,8
	17	12	347,5	91,1	327,5	99,6	305,6	109,0	283,1	119,2	260,5	129,3
294	10	5	318,2	88,7	288,6	103,2	270,6	113,1	250,8	124,4	228,9	136,3
	12	7	324,6	95,9	306,7	104,7	287,4	114,9	265,8	126,0	243,2	137,8
	14	9	344,8	97,4	324,8	106,6	304,2	116,7	280,9	127,9	258,2	139,3
	15	10	354,3	98,3	334,7	107,4	312,4	117,6	289,0	128,9	265,8	140,2
	17	12	375,6	100,1	353,5	109,3	330,1	119,4	305,9	130,6	281,4	141,8
324	10	5	326,9	101,0	307,6	110,5	287,2	120,9	265,0	133,1	242,5	145,5
	12	7	346,4	102,8	326,3	112,3	304,4	122,9	280,9	135,1	257,5	147,2
	14	9	366,6	104,5	345,0	114,4	322,1	125,2	297,4	137,1	272,4	149,1
	15	10	377,1	105,6	354,6	115,3	330,9	126,2	306,0	138,2	280,4	150,0
	17	12	398,4	107,5	375,0	117,5	349,7	128,3	323,0	140,4	297,0	151,7

Tbs<sub>1</sub> Air inlet temperature (dry bulb)  
 Tw<sub>1/2</sub> Water inlet/outlet temperature  
 PF Cooling capacity  
 PA Total power input including pump

**Tab.16- Cooling capacities of LCE CQ water chillers, QUIET (Super Low Noise) version**

LCE . . . CQ	Tbs <sub>1</sub> (°C)		25		30		35		40		45	
	Tw <sub>1</sub>	Tw <sub>2</sub>	PF	PA	PF	PA	PF	PA	PF	PA	PF	PA
	°C		kW		kW		kW		kW		kW	
<b>042</b>	10	5	51,4	13,0	48,0	14,6	45,2	15,9	42,1	17,5	38,9	19,2
	12	7	55,1	13,1	51,1	14,8	48,0	16,2	44,8	17,7	41,3	19,5
	14	9	59,1	13,2	54,2	15,1	51,0	16,5	47,5	18,0	43,8	19,7
	15	10	61,1	13,2	55,9	15,3	52,4	16,6	48,8	18,2	45,0	19,9
	17	12	62,5	14,3	59,1	15,6	55,6	16,9	51,6	18,5	47,7	20,1
<b>052</b>	10	5	57,2	14,3	52,4	16,6	49,2	18,2	45,7	20,0	41,8	22,1
	12	7	61,7	14,3	55,8	16,9	52,3	18,5	48,4	20,4	44,4	22,3
	14	9	62,8	15,8	59,3	17,2	55,3	18,9	51,3	20,7	47,3	22,6
	15	10	64,9	15,9	61,0	17,4	56,9	19,1	52,8	20,9	48,6	22,8
	17	12	68,7	16,2	64,5	17,7	60,2	19,4	55,9	21,2	51,5	23,1
<b>062</b>	10	5	67,8	17,8	63,7	19,8	59,9	21,7	55,9	23,8	51,6	26,2
	12	7	72,6	17,8	67,7	20,1	63,7	22,0	59,5	24,1	54,8	26,6
	14	9	77,6	17,9	71,9	20,4	67,7	22,3	63,1	24,5	58,3	26,9
	15	10	80,1	17,9	74,0	20,5	69,7	22,5	64,9	24,7	60,0	27,1
	17	12	85,5	17,9	78,3	20,9	73,8	22,9	68,9	25,1	63,7	27,5
<b>072</b>	10	5	67,8	17,8	63,7	19,8	59,9	21,7	55,9	23,8	51,6	26,2
	12	7	72,6	17,8	67,7	20,1	63,7	22,0	59,5	24,1	54,8	26,6
	14	9	77,6	17,9	71,9	20,4	67,7	22,3	63,1	24,5	58,3	26,9
	15	10	80,1	17,9	74,0	20,5	69,7	22,5	64,9	24,7	60,0	27,1
	17	12	85,5	17,9	78,3	20,9	73,8	22,9	68,9	25,1	63,7	27,5
<b>082</b>	10	5	86,5	21,1	77,9	25,1	72,8	27,8	67,3	30,7	61,4	33,9
	12	7	88,0	23,2	82,7	25,6	77,4	28,2	71,6	31,1	65,6	34,2
	14	9	93,4	23,6	88,1	25,9	82,2	28,6	76,0	31,5	69,7	34,5
	15	10	96,3	23,7	90,5	26,2	84,7	28,8	78,3	31,8	72,1	34,6
	17	12	101,8	24,2	95,9	26,6	89,8	29,3	83,1	32,2	76,6	35,0
<b>091</b>	10	5	100,7	24,8	93,3	28,5	87,3	31,6	81,1	35,1	74,3	38,9
	12	7	108,1	24,8	99,1	28,9	92,9	32,0	86,2	35,5	79,2	39,3
	14	9	115,6	24,8	105,3	29,4	98,6	32,5	91,6	36,0	84,2	39,7
	15	10	119,5	24,8	108,3	29,6	101,6	32,7	94,2	36,2	86,8	40,0
	17	12	121,4	27,3	114,8	30,1	107,6	33,2	100,0	36,7	92,2	40,4
<b>092</b>	10	5	100,7	24,8	93,3	28,5	87,3	31,6	81,1	35,1	74,3	38,9
	12	7	108,1	24,8	99,1	28,9	92,9	32,0	86,2	35,5	79,2	39,3
	14	9	115,6	24,8	105,3	29,4	98,6	32,5	91,6	36,0	84,2	39,7
	15	10	119,5	24,8	108,3	29,6	101,6	32,7	94,2	36,2	86,8	40,0
	17	12	121,4	27,3	114,8	30,1	107,6	33,2	100,0	36,7	92,2	40,4

LCE...CQ	Tbs <sub>1</sub> (°C)		25		30		35		40		45	
	Tw <sub>1</sub>	Tw <sub>2</sub>	PF	PA	PF	PA	PF	PA	PF	PA	PF	PA
	°C		kW		kW		kW		kW		kW	
094	10	5	101,6	25,6	94,3	29,1	88,7	31,8	82,7	34,9	76,3	38,4
	12	7	108,9	25,7	100,2	29,6	94,3	32,3	87,8	35,5	81,0	38,9
	14	9	116,6	25,9	106,3	30,1	99,8	32,9	93,0	36,0	85,9	39,4
	15	10	115,6	28,0	109,3	30,5	102,8	33,3	95,6	36,4	88,2	39,7
	17	12	122,4	28,6	115,8	31,1	108,6	33,9	101,0	37,0	93,4	40,2
101	10	5	115,6	28,2	104,2	34,0	97,4	37,8	89,9	42,0	82,4	46,4
	12	7	117,6	31,1	110,7	34,5	103,4	38,4	95,6	42,5	87,5	47,0
	14	9	124,6	31,7	117,3	35,2	109,6	39,0	101,5	43,2	93,1	47,5
	15	10	128,0	32,0	120,8	35,4	112,9	39,3	104,3	43,6	96,0	47,8
	17	12	135,6	32,7	127,7	36,1	119,2	40,0	110,6	44,2	101,6	48,4
102	10	5	115,7	28,2	104,1	34,0	97,5	37,8	90,1	42,0	82,4	46,4
	12	7	117,4	31,1	110,7	34,5	103,5	38,4	95,7	42,5	87,5	47,0
	14	9	124,6	31,7	117,2	35,2	109,6	39,0	101,5	43,2	93,1	47,5
	15	10	128,0	32,0	120,8	35,4	112,8	39,3	104,3	43,6	96,0	47,8
	17	12	135,8	32,7	127,7	36,1	119,0	40,0	110,6	44,2	101,6	48,4
104	10	5	112,8	28,1	102,6	33,1	96,4	36,4	89,2	40,1	81,7	44,0
	12	7	115,7	30,8	109,0	33,8	102,2	37,1	94,6	40,8	86,9	44,6
	14	9	122,8	31,5	115,8	34,4	108,2	37,7	100,3	41,5	92,1	45,2
	15	10	126,6	31,8	119,1	34,8	111,4	38,1	103,0	41,8	94,8	45,6
	17	12	134,2	32,5	125,8	35,5	117,4	38,8	109,1	42,6	100,6	46,1
121	10	5	134,8	35,5	124,1	40,6	116,2	44,5	107,8	48,9	98,8	53,7
	12	7	144,5	35,5	132,0	41,1	123,6	45,0	114,6	49,5	105,0	54,3
	14	9	154,5	35,5	140,0	41,6	131,0	45,7	121,7	50,1	111,6	54,9
	15	10	152,7	38,4	144,1	42,0	135,0	46,0	125,1	50,5	115,0	55,2
	17	12	161,5	39,0	152,5	42,6	142,8	46,7	132,4	51,1	122,0	55,7
122	10	5	134,8	35,5	124,1	40,6	116,2	44,5	107,8	48,9	98,8	53,7
	12	7	144,5	35,5	132,0	41,1	123,6	45,0	114,6	49,5	105,0	54,3
	14	9	154,5	35,5	140,0	41,6	131,0	45,7	121,7	50,1	111,6	54,9
	15	10	152,7	38,4	144,1	42,0	135,0	46,0	125,1	50,5	115,0	55,2
	17	12	161,5	39,0	152,5	42,6	142,8	46,7	132,4	51,1	122,0	55,7
124	10	5	136,7	35,7	126,3	40,5	118,5	44,3	110,1	48,5	101,2	53,1
	12	7	146,4	35,8	133,9	41,2	125,7	45,0	116,8	49,3	107,8	53,8
	14	9	150,1	38,5	141,9	41,9	133,1	45,7	123,9	50,0	114,4	54,5
	15	10	154,3	38,8	146,2	42,2	137,1	46,1	127,5	50,4	117,5	54,9
	17	12	163,3	39,4	154,4	43,0	144,9	46,9	134,7	51,2	124,7	55,6
141	10	5	151,5	39,4	136,9	46,1	127,7	50,4	118,2	55,2	107,7	60,3
	12	7	154,0	42,9	145,2	46,8	135,5	51,1	125,3	56,0	114,4	61,0
	14	9	163,2	43,6	153,8	47,5	143,5	51,9	132,6	56,8	121,8	61,6
	15	10	168,2	43,8	158,5	47,8	147,9	52,2	136,5	57,2	125,2	61,9
	17	12	177,5	44,5	167,5	48,6	156,0	53,1	144,3	58,0	132,4	62,6

LCE...CQ	Tbs <sub>1</sub> (°C)		25		30		35		40		45	
	Tw <sub>1</sub>	Tw <sub>2</sub>	PF	PA	PF	PA	PF	PA	PF	PA	PF	PA
	°C		kW		kW		kW		kW		kW	
142	10	5	151,5	39,4	136,9	46,1	127,7	50,4	118,2	55,2	107,7	60,3
	12	7	154,0	42,9	145,2	46,8	135,5	51,1	125,3	56,0	114,4	61,0
	14	9	163,2	43,6	153,8	47,5	143,5	51,9	132,6	56,8	121,8	61,6
	15	10	168,2	43,8	158,5	47,8	147,9	52,2	136,5	57,2	125,2	61,9
	17	12	177,5	44,5	167,5	48,6	156,0	53,1	144,3	58,0	132,4	62,6
144	10	5	147,6	41,5	139,0	45,6	129,8	50,0	119,8	55,3	109,0	60,9
	12	7	156,7	42,2	147,5	46,3	137,6	50,8	126,9	56,1	115,8	61,5
	14	9	166,0	43,0	156,1	47,1	145,6	51,7	134,2	57,0	123,3	62,1
	15	10	170,7	43,4	160,7	47,5	149,7	52,1	138,2	57,4	126,7	62,5
	17	12	180,1	44,2	169,7	48,4	158,3	53,0	146,0	58,3	134,2	63,2
161	10	5	163,3	50,9	153,9	55,6	143,5	61,0	131,8	66,8	119,9	72,4
	12	7	173,5	51,8	162,9	56,7	151,9	62,0	139,2	67,8	127,2	73,3
	14	9	183,6	52,9	172,1	57,7	159,8	63,1	146,9	68,9	134,6	74,2
	15	10	188,9	53,4	176,7	58,3	164,0	63,6	151,2	69,3	138,5	74,7
	17	12	199,2	54,5	186,1	59,4	172,9	64,8	159,5	70,3	-	-
162	10	5	164,2	50,9	153,9	55,6	143,0	60,8	131,6	66,8	119,9	72,4
	12	7	173,6	51,9	162,8	56,6	151,5	62,0	139,2	67,8	127,2	73,3
	14	9	183,6	52,9	172,1	57,7	159,8	63,1	146,9	68,9	134,6	74,2
	15	10	188,8	53,4	176,8	58,3	164,2	63,6	151,2	69,3	138,5	74,7
	17	12	199,0	54,5	186,5	59,4	173,3	64,8	159,5	70,3	-	-
164	10	5	161,7	48,4	151,9	53,2	141,3	58,5	129,8	64,6	118,7	70,4
	12	7	171,8	49,2	161,2	54,0	150,1	59,4	138,3	65,4	126,4	71,1
	14	9	182,0	50,1	171,0	54,9	159,0	60,3	146,5	66,3	134,5	71,8
	15	10	187,0	50,6	176,0	55,4	163,6	60,9	150,8	66,7	138,8	72,1
	17	12	198,1	51,5	185,8	56,5	173,0	61,9	160,0	67,6	-	-
194	10	5	179,5	65,3	167,6	72,2	155,3	79,7	142,0	87,7	119,9	95,5
	12	7	190,1	66,6	177,6	73,4	164,4	81,1	150,5	89,0	119,9	95,5
	14	9	201,0	68,1	187,6	75,1	173,5	82,8	159,8	90,2	119,9	95,5
	15	10	206,4	68,8	192,5	75,9	178,3	83,6	164,0	90,9	119,9	95,5
	17	12	217,4	70,4	203,4	77,4	188,0	85,1	173,5	92,3	119,9	95,5
214	10	5	209,3	72,3	196,5	80,2	182,5	89,0	166,6	98,6	152,1	107,7
	12	7	221,7	73,9	207,8	81,9	192,6	90,8	176,6	100,3	161,1	109,3
	14	9	234,3	75,6	219,2	83,6	203,1	92,6	186,9	101,9	137,3	110,5
	15	10	240,4	76,4	225,3	84,5	208,6	93,5	192,1	102,8	137,3	110,5
	17	12	253,7	78,3	236,9	86,4	219,8	95,6	202,7	104,5	137,3	110,5
244	10	5	231,3	80,4	215,3	88,7	198,4	97,7	181,4	107,0	156,2	114,2
	12	7	244,1	82,2	227,4	90,5	209,6	99,7	191,7	108,7	156,2	114,2
	14	9	257,3	84,1	239,8	92,6	220,8	101,8	202,6	110,5	156,2	114,2
	15	10	264,1	85,1	245,6	93,6	226,6	102,8	208,2	111,4	156,2	114,2
	17	12	277,5	87,2	258,5	95,8	238,4	104,7	215,2	114,2	156,2	114,2

LCE...CQ	Tbs <sub>1</sub> (°C)		25		30		35		40		45	
	Tw <sub>1</sub>	Tw <sub>2</sub>	PF	PA	PF	PA	PF	PA	PF	PA	PF	PA
	°C		kW		kW		kW		kW		kW	
<b>274</b>	10	5	278,9	86,5	262,9	94,9	245,7	104,0	226,8	114,5	206,9	125,4
	12	7	296,3	87,8	279,1	96,3	260,7	105,6	240,7	116,1	220,0	126,8
	14	9	314,0	89,2	295,7	97,8	275,9	107,3	255,1	117,7	233,7	128,3
	15	10	322,7	90,0	303,7	98,6	283,8	108,2	262,3	118,7	240,2	129,1
	17	12	341,0	91,6	321,6	100,3	300,2	109,8	277,2	120,4	255,0	130,5
<b>294</b>	10	5	299,3	95,7	281,4	105,0	263,3	115,4	242,2	126,9	220,8	138,6
	12	7	317,2	97,4	298,9	106,9	278,7	117,3	256,6	128,9	234,3	140,2
	14	9	336,4	99,4	316,2	108,8	294,3	119,3	271,2	130,9	248,6	142,0
	15	10	346,1	100,2	324,9	109,7	302,5	120,4	278,6	131,9	255,7	142,7
	17	12	365,3	102,2	342,9	111,7	318,7	122,5	294,4	134,0	270,6	144,7
<b>324</b>	10	5	318,1	102,9	298,5	112,7	277,7	123,9	254,8	136,4	232,7	148,4
	12	7	337,0	104,8	315,8	114,9	293,8	126,1	270,3	138,5	247,0	150,3
	14	9	355,9	107,0	334,1	117,2	310,5	128,4	285,2	140,8	261,2	152,2
	15	10	365,2	108,2	343,4	118,2	318,8	129,7	293,6	141,8	268,9	153,1
	17	12	385,8	110,5	361,5	120,8	335,9	132,2	309,4	144,1	207,9	154,8



# Performance



Tbs<sub>1</sub> Air inlet temperature (dry bulb)  
 Tw<sub>1/2</sub> Water inlet/outlet temperature  
 PF Cooling capacity  
 PA Total power input including pump

**Tab.17- Cooling capacities of LCE HS reversible heat pumps, STANDARD version**

LCE . . . HS	Tbs <sub>1</sub> (°C)		25		30		35		40		45	
	Tw <sub>1</sub>	Tw <sub>2</sub>	PF	PA	PF	PA	PF	PA	PF	PA	PF	PA
	°C		kW		kW		kW		kW		kW	
<b>062</b>	10	5	67,8	18,1	63,3	20,3	59,5	22,2	55,4	24,4	51,0	26,9
	12	7	72,6	18,2	67,2	20,7	63,3	22,6	58,8	24,8	54,3	27,2
	14	9	77,6	18,2	71,4	21,0	67,0	23,0	62,5	25,2	57,7	27,6
	15	10	80,1	18,2	73,4	21,1	69,0	23,2	64,4	25,4	59,4	27,8
	17	12	82,1	19,7	77,8	21,5	73,1	23,5	68,2	25,7	63,0	28,1
<b>072</b>	10	5	76,6	19,4	69,7	22,7	65,3	25,0	60,2	27,6	55,0	30,6
	12	7	81,9	19,5	74,0	23,0	69,2	25,4	64,0	28,0	58,5	30,9
	14	9	83,4	21,3	78,5	23,4	73,3	25,8	67,9	28,4	62,2	31,2
	15	10	85,8	21,5	80,9	23,6	75,4	26,0	69,9	28,6	64,0	31,4
	17	12	90,6	22,0	85,4	24,1	79,9	26,4	73,8	29,1	67,8	31,7
<b>082</b>	10	5	82,0	23,5	77,2	25,9	72,0	28,5	66,3	31,6	60,6	34,7
	12	7	87,1	23,9	82,0	26,3	76,5	29,0	70,5	32,0	64,7	34,9
	14	9	92,5	24,4	87,1	26,7	81,3	29,4	75,0	32,4	69,0	35,3
	15	10	95,2	24,5	89,6	26,9	83,6	29,7	77,3	32,6	71,1	35,5
	17	12	100,9	25,0	94,8	27,4	88,6	30,1	81,9	33,1	75,5	35,8
<b>091</b>	10	5	100,7	25,5	92,5	29,6	86,6	32,7	80,3	36,2	73,6	40,0
	12	7	108,1	25,5	98,3	30,0	92,2	33,1	85,4	36,6	78,4	40,4
	14	9	110,6	27,6	104,3	30,4	97,8	33,5	90,8	37,0	83,5	40,8
	15	10	114,0	27,8	107,5	30,6	100,8	33,8	93,6	37,3	86,0	41,0
	17	12	120,7	28,3	114,0	31,1	106,8	34,3	99,3	37,8	91,3	41,4
<b>092</b>	10	5	100,7	25,5	92,4	29,6	86,6	32,7	80,3	36,2	73,5	40,0
	12	7	108,1	25,5	98,3	30,0	92,2	33,1	85,4	36,6	78,4	40,4
	14	9	110,6	27,6	104,3	30,4	97,8	33,5	90,8	37,0	83,5	40,8
	15	10	114,0	27,8	107,5	30,6	100,8	33,8	93,5	37,3	86,0	41,0
	17	12	120,7	28,3	114,0	31,1	106,8	34,3	99,3	37,8	91,3	41,4
<b>101</b>	10	5	109,9	31,7	103,5	35,1	96,6	38,9	89,2	43,1	81,6	47,5
	12	7	116,8	32,2	109,7	35,7	102,7	39,5	94,9	43,7	86,9	48,0
	14	9	123,6	32,8	116,4	36,2	108,9	40,1	100,5	44,4	92,4	48,6
	15	10	127,4	33,1	119,7	36,6	111,9	40,4	103,5	44,7	95,0	48,9
	17	12	134,5	33,8	126,7	37,2	118,2	41,1	109,5	45,4	100,8	49,5
<b>102</b>	10	5	109,7	31,7	103,4	35,1	96,7	38,9	89,4	43,1	81,6	47,5
	12	7	116,7	32,2	109,7	35,7	102,8	39,5	94,9	43,7	86,9	48,0
	14	9	123,5	32,8	116,4	36,2	108,9	40,1	100,5	44,4	92,4	48,6
	15	10	127,4	33,1	119,7	36,6	111,8	40,4	103,5	44,7	95,0	48,9
	17	12	134,6	33,8	126,7	37,2	118,2	41,0	109,5	45,4	100,8	49,5

LCE ... HS	Tbs <sub>1</sub> (°C)		25		30		35		40		45	
	Tw <sub>1</sub>	Tw <sub>2</sub>	PF	PA	PF	PA	PF	PA	PF	PA	PF	PA
	°C		kW		kW		kW		kW		kW	
121	10	5	134,8	33,8	124,7	38,6	116,9	42,5	108,4	46,9	99,3	51,8
	12	7	144,5	33,8	132,5	39,2	124,1	43,1	115,2	47,5	105,8	52,3
	14	9	154,5	33,8	140,5	39,7	131,8	43,7	122,3	48,1	112,5	52,8
	15	10	153,2	36,5	144,5	40,0	135,8	44,0	126,0	48,4	115,6	53,2
	17	12	162,0	37,1	153,4	40,6	143,7	44,6	133,5	49,0	122,9	53,7
122	10	5	134,8	33,8	124,7	38,6	116,9	42,5	108,4	46,9	99,3	51,8
	12	7	144,5	33,8	132,5	39,2	124,1	43,1	115,2	47,5	105,9	52,3
	14	9	154,5	33,8	140,5	39,7	131,8	43,7	122,3	48,1	112,5	52,8
	15	10	153,2	36,5	144,5	40,0	135,8	44,0	126,0	48,4	115,6	53,2
	17	12	162,0	37,1	153,4	40,6	143,7	44,6	133,5	49,0	122,9	53,7
124	10	5	137,0	34,0	126,9	38,6	119,3	42,3	110,9	46,4	101,9	51,1
	12	7	146,6	34,1	134,6	39,2	126,4	43,0	117,8	47,1	108,5	51,7
	14	9	156,5	34,1	142,7	39,9	134,1	43,6	124,9	47,8	115,2	52,3
	15	10	155,3	36,8	146,6	40,2	138,1	44,0	128,6	48,2	118,6	52,7
	17	12	164,1	37,4	155,5	40,9	146,0	44,6	135,9	49,0	125,7	53,4
141	10	5	151,5	37,7	139,1	43,4	130,1	47,5	120,6	52,3	110,2	57,4
	12	7	162,4	37,7	147,7	44,0	138,4	48,2	128,1	52,9	117,2	58,0
	14	9	165,7	40,8	156,7	44,6	146,4	48,9	135,7	53,7	124,7	58,6
	15	10	170,9	41,1	161,1	45,0	150,8	49,3	139,7	54,0	128,2	59,0
	17	12	180,7	41,7	170,6	45,6	159,5	50,0	148,0	54,7	136,0	59,5
142	10	5	151,5	37,7	139,1	43,4	130,1	47,5	120,6	52,3	110,2	57,4
	12	7	162,4	37,7	147,7	44,0	138,4	48,2	128,1	52,9	117,2	58,0
	14	9	165,7	40,8	156,7	44,6	146,4	48,9	135,7	53,7	124,7	58,6
	15	10	170,9	41,1	161,1	45,0	150,8	49,3	139,7	54,0	128,2	59,0
	17	12	180,7	41,7	170,6	45,6	159,5	50,0	148,0	54,7	136,0	59,5
144	10	5	154,5	36,7	141,3	42,6	132,1	47,0	122,3	52,1	111,8	57,6
	12	7	165,2	36,8	150,0	43,3	140,4	47,8	129,9	52,8	118,8	58,2
	14	9	168,8	40,0	159,0	44,0	148,7	48,4	137,8	53,5	126,4	58,8
	15	10	173,3	40,5	163,8	44,4	153,1	48,8	141,5	53,9	129,9	59,2
	17	12	183,9	41,2	173,4	45,1	161,9	49,6	149,9	54,7	137,7	59,8
161	10	5	166,4	47,9	156,6	52,5	146,7	57,7	135,4	63,4	123,2	69,2
	12	7	176,8	48,8	166,4	53,4	155,4	58,6	143,2	64,3	130,9	70,0
	14	9	187,1	49,7	176,3	54,4	164,0	59,6	151,2	65,3	138,6	70,8
	15	10	192,6	50,3	180,8	55,0	168,3	60,1	155,5	65,8	142,6	71,2
	17	12	203,7	51,2	191,0	55,9	177,4	61,2	163,9	66,9	150,9	72,2
162	10	5	166,9	47,9	156,9	52,5	146,3	57,5	135,0	63,3	123,2	69,2
	12	7	176,9	48,8	166,4	53,4	155,0	58,6	143,0	64,3	130,9	70,0
	14	9	187,2	49,7	176,3	54,4	164,0	59,6	151,2	65,3	138,6	70,8
	15	10	192,5	50,3	180,8	55,0	168,5	60,1	155,5	65,8	142,6	71,2
	17	12	203,3	51,2	190,8	56,0	177,9	61,2	163,9	66,9	150,9	72,2

LCE ... HS	Tbs <sub>1</sub> (°C)		25		30		35		40		45	
	Tw <sub>1</sub>	Tw <sub>2</sub>	PF	PA	PF	PA	PF	PA	PF	PA	PF	PA
	°C		kW		kW		kW		kW		kW	
164	10	5	164,2	45,5	154,6	50,1	144,2	55,3	133,2	61,0	121,6	67,2
	12	7	174,5	46,2	164,2	50,9	153,4	56,0	141,5	61,9	129,8	67,7
	14	9	185,2	47,0	174,5	51,6	162,9	56,8	150,4	62,8	138,0	68,4
	15	10	190,8	47,5	179,2	52,1	167,6	57,4	154,7	63,2	142,4	68,8
	17	12	201,6	48,3	190,1	53,0	177,2	58,4	163,8	64,1	151,1	69,5
174	10	5	169,2	47,8	161,6	51,4	152,0	56,3	141,9	61,8	130,8	68,0
	12	7	181,3	47,8	172,3	52,0	162,0	56,8	151,6	62,3	139,8	68,5
	14	9	194,1	47,7	183,1	52,5	172,5	57,4	161,3	62,8	149,1	69,0
	15	10	201,2	47,7	189,2	52,7	178,2	57,7	166,3	63,2	153,8	69,3
	17	12	215,1	47,7	201,2	53,3	189,4	58,3	177,1	63,8	163,8	69,9
194	10	5	199,8	56,7	186,7	63,7	174,9	70,1	162,9	77,3	149,4	85,4
	12	7	214,0	56,7	198,4	64,4	186,6	70,7	173,4	78,0	159,4	86,2
	14	9	229,0	56,7	211,1	65,2	198,0	71,7	184,4	78,9	170,0	86,9
	15	10	237,3	56,7	217,6	65,6	204,1	72,0	190,0	79,4	175,3	87,4
	17	12	253,4	56,7	230,2	66,6	216,7	73,1	201,6	80,4	186,2	88,2
214	10	5	230,4	63,5	209,8	74,3	196,9	82,1	182,6	90,8	166,7	100,3
	12	7	247,1	63,5	223,1	75,4	209,0	83,3	193,8	91,9	177,5	101,4
	14	9	250,9	69,6	236,9	76,5	221,4	84,5	205,6	93,1	188,7	102,5
	15	10	258,3	70,1	243,7	77,1	228,5	84,9	211,7	93,8	195,0	102,9
	17	12	274,0	71,2	257,7	78,4	241,6	86,2	223,8	95,2	206,5	104,2
244	10	5	255,1	74,1	237,8	83,3	223,5	91,7	207,5	101,0	189,9	111,4
	12	7	273,0	74,1	252,6	84,5	237,0	92,9	220,6	102,2	201,9	112,8
	14	9	292,4	74,1	267,8	85,8	251,5	94,1	233,7	103,7	214,5	114,0
	15	10	302,2	74,1	276,0	86,4	259,1	94,8	240,1	104,5	221,0	114,7
	17	12	308,4	80,1	292,4	87,7	274,0	96,3	254,6	105,7	234,5	115,9
274	10	5	294,3	83,3	272,5	94,2	255,4	103,0	236,5	112,9	216,9	123,7
	12	7	314,9	83,3	289,5	95,5	271,6	104,2	252,0	114,0	231,2	124,7
	14	9	337,2	83,3	307,0	96,6	288,5	105,4	267,5	115,3	245,6	126,0
	15	10	348,4	83,3	316,3	97,2	296,5	106,2	275,4	116,1	253,0	126,5
	17	12	354,8	90,3	335,0	98,6	314,4	107,4	291,9	117,5	269,0	127,8
294	10	5	318,7	90,9	295,4	101,9	277,9	111,4	259,1	122,1	237,2	133,9
	12	7	340,6	90,9	314,7	103,1	295,5	112,8	274,8	123,7	252,0	135,6
	14	9	364,4	91,0	334,2	104,7	313,7	114,2	291,5	125,1	267,6	136,8
	15	10	376,4	91,0	343,8	105,4	323,0	115,1	299,6	125,9	275,6	137,7
	17	12	385,7	98,0	364,0	107,0	341,4	116,8	317,1	127,5	292,1	139,1
324	10	5	343,3	94,9	315,7	108,2	296,1	118,3	274,6	129,8	251,4	142,4
	12	7	367,1	95,1	335,7	109,9	313,9	120,2	290,9	131,5	266,9	144,0
	14	9	392,2	95,2	355,1	111,6	333,1	121,8	309,1	133,3	283,8	145,7
	15	10	387,4	103,2	365,8	112,5	342,2	122,8	317,4	134,4	292,2	146,3
	17	12	409,4	104,8	387,0	114,3	362,5	124,8	336,1	136,2	308,7	148,3

# Performance



Tbs<sub>1</sub> Air inlet temperature (dry bulb)  
 Tw<sub>1/2</sub> Water inlet/outlet temperature  
 PF Cooling capacity  
 PA Total power input including pump

**Tab.18- Cooling capacities of LCE HL reversible heat pumps, LOW NOISE version**

LCE . . . HL	Tbs <sub>1</sub> (°C)		25		30		35		40		45	
	Tw <sub>1</sub>	Tw <sub>2</sub>	PF	PA	PF	PA	PF	PA	PF	PA	PF	PA
	°C		kW		kW		kW		kW		kW	
042	10	5	51,4	13,0	48,0	14,6	45,2	15,9	42,1	17,5	38,9	19,2
	12	7	55,1	13,1	51,1	14,8	48,0	16,2	44,8	17,7	41,3	19,5
	14	9	59,1	13,2	54,2	15,1	51,0	16,5	47,5	18,0	43,8	19,7
	15	10	61,1	13,2	55,9	15,3	52,4	16,6	48,8	18,2	45,0	19,9
	17	12	62,5	14,3	59,1	15,6	55,6	16,9	51,6	18,5	47,7	20,1
052	10	5	57,2	14,3	52,4	16,6	49,2	18,2	45,7	20,0	41,8	22,1
	12	7	61,7	14,3	55,8	16,9	52,3	18,5	48,4	20,4	44,4	22,3
	14	9	62,8	15,8	59,3	17,2	55,3	18,9	51,3	20,7	47,3	22,6
	15	10	64,9	15,9	61,0	17,4	56,9	19,1	52,8	20,9	48,6	22,8
	17	12	68,7	16,2	64,5	17,7	60,2	19,4	55,9	21,2	51,5	23,1
062	10	5	67,8	17,8	63,7	19,8	59,9	21,7	55,9	23,8	51,6	26,2
	12	7	72,6	17,8	67,7	20,1	63,7	22,0	59,5	24,1	54,8	26,6
	14	9	77,6	17,9	71,9	20,4	67,7	22,3	63,1	24,5	58,3	26,9
	15	10	80,1	17,9	74,0	20,5	69,7	22,5	64,9	24,7	60,0	27,1
	17	12	85,5	17,9	78,3	20,9	73,8	22,9	68,9	25,1	63,7	27,5
072	10	5	76,6	19,1	70,5	22,0	65,8	24,3	60,9	26,9	55,7	29,8
	12	7	81,9	19,1	74,8	22,3	69,9	24,7	64,7	27,3	59,2	30,2
	14	9	87,7	19,2	79,2	22,7	74,2	25,0	68,7	27,6	62,9	30,5
	15	10	86,6	20,9	81,6	22,9	76,4	25,2	70,6	27,9	64,9	30,6
	17	12	91,7	21,2	86,4	23,4	80,8	25,6	74,9	28,2	68,7	31,0
082	10	5	86,5	21,1	77,9	25,1	72,8	27,8	67,3	30,7	61,4	33,9
	12	7	88,0	23,2	82,7	25,6	77,4	28,2	71,6	31,1	65,6	34,2
	14	9	93,4	23,6	88,1	25,9	82,2	28,6	76,0	31,5	69,7	34,5
	15	10	96,3	23,7	90,5	26,2	84,7	28,8	78,3	31,8	72,1	34,6
	17	12	101,8	24,2	95,9	26,6	89,8	29,3	83,1	32,2	76,6	35,0
091	10	5	100,7	24,8	93,3	28,5	87,3	31,6	81,1	35,1	74,3	38,9
	12	7	108,1	24,8	99,1	28,9	92,9	32,0	86,2	35,5	79,2	39,3
	14	9	115,6	24,8	105,3	29,4	98,6	32,5	91,6	36,0	84,2	39,7
	15	10	119,5	24,8	108,3	29,6	101,6	32,7	94,2	36,2	86,8	40,0
	17	12	121,4	27,3	114,8	30,1	107,6	33,2	100,0	36,7	92,2	40,4
092	10	5	100,7	24,8	93,3	28,5	87,3	31,6	81,1	35,1	74,3	38,9
	12	7	108,1	24,8	99,1	28,9	92,9	32,0	86,2	35,5	79,2	39,3
	14	9	115,6	24,8	105,3	29,4	98,6	32,5	91,6	36,0	84,2	39,7
	15	10	119,5	24,8	108,3	29,6	101,6	32,7	94,2	36,2	86,8	40,0
	17	12	121,4	27,3	114,8	30,1	107,6	33,2	100,0	36,7	92,2	40,4
094	10	5	101,6	25,6	94,3	29,1	88,7	31,8	82,7	34,9	76,3	38,4
	12	7	108,9	25,7	100,2	29,6	94,3	32,3	87,8	35,5	81,0	38,9
	14	9	116,6	25,9	106,3	30,1	99,8	32,9	93,0	36,0	85,9	39,4
	15	10	115,6	28,0	109,3	30,5	102,8	33,3	95,6	36,4	88,2	39,7
	17	12	122,4	28,6	115,8	31,1	108,6	33,9	101,0	37,0	93,4	40,2
101	10	5	115,6	28,2	104,2	34,0	97,4	37,8	89,9	42,0	82,4	46,4
	12	7	117,6	31,1	110,7	34,5	103,4	38,4	95,6	42,5	87,5	47,0
	14	9	124,6	31,7	117,3	35,2	109,6	39,0	101,5	43,2	93,1	47,5
	15	10	128,0	32,0	120,8	35,4	112,9	39,3	104,3	43,6	96,0	47,8
	17	12	135,6	32,7	127,7	36,1	119,2	40,0	110,6	44,2	101,6	48,4

LCE . . . HL	Tbs <sub>1</sub> (°C)		25		30		35		40		45	
	Tw <sub>1</sub>	Tw <sub>2</sub>	PF	PA	PF	PA	PF	PA	PF	PA	PF	PA
	°C		kW		kW		kW		kW		kW	
102	10	5	115,7	28,2	104,1	34,0	97,5	37,8	90,1	42,0	82,4	46,4
	12	7	117,4	31,1	110,7	34,5	103,5	38,4	95,7	42,5	87,5	47,0
	14	9	124,6	31,7	117,2	35,2	109,6	39,0	101,5	43,2	93,1	47,5
	15	10	128,0	32,0	120,8	35,4	112,8	39,3	104,3	43,6	96,0	47,8
	17	12	135,8	32,7	127,7	36,1	119,0	40,0	110,6	44,2	101,6	48,4
104	10	5	112,8	28,1	102,6	33,1	96,4	36,4	89,2	40,1	81,7	44,0
	12	7	115,7	30,8	109,0	33,8	102,2	37,1	94,6	40,8	86,9	44,6
	14	9	122,8	31,5	115,8	34,4	108,2	37,7	100,3	41,5	92,1	45,2
	15	10	126,6	31,8	119,1	34,8	111,4	38,1	103,0	41,8	94,8	45,6
	17	12	134,2	32,5	125,8	35,5	117,4	38,8	109,1	42,6	100,6	46,1
121	10	5	134,8	35,5	125,4	40,0	117,6	43,9	109,4	48,1	100,1	52,9
	12	7	144,5	35,5	133,4	40,5	125,1	44,4	116,3	48,7	106,7	53,5
	14	9	154,5	35,5	141,5	41,0	132,9	44,9	123,5	49,2	113,4	54,0
	15	10	160,0	35,5	145,8	41,2	136,6	45,2	126,9	49,6	116,8	54,4
	17	12	163,2	38,3	154,4	41,8	144,9	45,7	134,8	50,2	123,9	54,9
122	10	5	134,8	35,5	125,4	40,0	117,6	43,9	109,4	48,1	100,1	52,9
	12	7	144,5	35,5	133,4	40,5	125,1	44,4	116,3	48,7	106,7	53,5
	14	9	154,5	35,5	141,5	41,0	132,9	44,9	123,5	49,2	113,4	54,0
	15	10	160,0	35,5	145,8	41,2	136,6	45,2	126,9	49,6	116,8	54,4
	17	12	163,2	38,3	154,4	41,8	144,9	45,7	134,8	50,2	123,9	54,9
124	10	5	136,9	35,6	127,5	39,9	119,9	43,5	111,9	47,5	102,9	52,2
	12	7	146,6	35,7	135,5	40,5	127,4	44,2	118,8	48,2	109,3	52,9
	14	9	156,4	35,7	143,8	41,0	135,1	44,8	126,0	48,9	116,2	53,4
	15	10	161,9	35,8	147,8	41,4	138,9	45,2	129,4	49,3	119,7	53,8
	17	12	165,0	38,7	156,4	42,0	147,1	45,8	137,3	50,0	126,8	54,5
141	10	5	151,5	39,4	138,6	45,3	129,6	49,6	120,0	54,2	109,6	59,3
	12	7	162,4	39,3	146,9	46,0	137,5	50,3	127,2	55,0	116,5	60,1
	14	9	165,0	42,8	156,1	46,6	146,1	50,9	135,0	55,7	124,1	60,5
	15	10	170,0	43,0	160,3	47,0	150,1	51,2	139,0	56,0	127,6	60,9
	17	12	179,9	43,7	169,7	47,7	158,8	51,9	147,3	56,7	135,6	61,5
142	10	5	151,5	39,4	138,6	45,3	129,6	49,6	120,0	54,2	109,6	59,3
	12	7	162,4	39,3	146,9	46,0	137,5	50,3	127,2	55,0	116,5	60,1
	14	9	165,0	42,8	156,1	46,6	146,1	50,9	135,0	55,7	124,1	60,5
	15	10	170,0	43,0	160,3	47,0	150,1	51,2	139,0	56,0	127,6	60,9
	17	12	179,9	43,7	169,7	47,7	158,8	51,9	147,3	56,7	135,6	61,5
144	10	5	154,5	38,4	140,9	44,6	131,6	49,1	121,7	54,1	111,1	59,7
	12	7	165,3	38,5	149,2	45,3	139,8	49,7	129,2	54,7	118,4	60,2
	14	9	167,7	42,1	158,5	46,0	148,1	50,5	136,8	55,6	125,4	60,9
	15	10	172,8	42,5	162,9	46,4	152,1	50,9	140,8	56,0	129,2	61,1
	17	12	182,7	43,3	172,4	47,1	160,9	51,7	149,1	56,7	136,9	61,9
161	10	5	166,3	49,5	156,9	54,1	147,0	59,2	135,8	64,9	123,3	70,8
	12	7	176,7	50,4	166,7	54,9	155,7	60,2	143,2	65,9	130,9	71,5
	14	9	187,4	51,3	176,3	55,9	164,4	61,1	151,6	66,8	138,8	72,5
	15	10	193,0	51,8	181,1	56,5	168,7	61,6	155,9	67,3	142,9	72,8
	17	12	204,0	52,8	191,4	57,4	177,9	62,6	164,3	68,5	151,3	73,7
162	10	5	167,2	49,5	157,2	54,1	146,7	59,1	135,1	64,9	123,3	70,8
	12	7	177,2	50,4	166,7	54,9	155,4	60,2	143,4	65,8	130,9	71,5
	14	9	187,5	51,3	176,3	55,9	164,4	61,1	151,6	66,8	138,8	72,5
	15	10	192,8	51,8	181,1	56,5	168,9	61,6	155,9	67,3	142,9	72,8
	17	12	203,7	52,8	191,2	57,5	178,0	62,8	164,3	68,5	151,3	73,7

LCE . . . HL	Tbs <sub>1</sub> (°C)		25		30		35		40		45	
	Tw <sub>1</sub>	Tw <sub>2</sub>	PF	PA	PF	PA	PF	PA	PF	PA	PF	PA
	°C		kW		kW		kW		kW		kW	
164	10	5	164,5	47,0	154,9	51,6	144,5	56,8	133,1	62,7	121,9	68,7
	12	7	174,8	47,8	164,5	52,4	153,7	57,6	141,9	63,4	129,9	69,3
	14	9	185,5	48,6	174,8	53,2	162,8	58,5	150,6	64,2	138,4	69,9
	15	10	191,1	49,0	179,6	53,7	167,9	58,9	154,9	64,8	142,8	70,3
	17	12	202,0	49,8	190,5	54,6	177,6	59,9	164,2	65,6	151,5	71,0
194	10	5	200,0	54,4	182,3	63,7	170,6	70,5	158,2	77,9	144,4	86,1
	12	7	214,2	54,4	193,8	64,6	181,2	71,4	168,0	79,0	153,9	87,0
	14	9	217,9	59,6	205,4	65,7	192,7	72,4	178,5	79,9	163,9	87,8
	15	10	224,7	60,1	211,7	66,2	198,2	72,9	183,6	80,5	169,0	88,3
	17	12	237,9	61,1	224,4	67,2	209,9	74,0	194,8	81,7	179,5	89,2
214	10	5	228,2	62,2	212,0	70,7	199,3	78,4	185,5	87,1	170,1	96,7
	12	7	244,7	62,2	225,6	71,8	211,9	79,5	197,0	88,2	180,7	97,9
	14	9	261,6	62,2	239,6	72,9	224,7	80,7	208,5	89,5	191,9	99,1
	15	10	270,3	62,2	246,4	73,5	231,0	81,3	214,6	90,2	197,8	99,8
	17	12	276,3	67,8	260,9	74,8	244,6	82,7	227,1	91,5	209,7	101,0
244	10	5	255,1	71,8	232,4	84,3	217,0	93,0	200,7	102,7	183,4	113,2
	12	7	261,3	77,9	246,4	85,7	230,3	94,4	212,8	104,2	195,1	114,4
	14	9	276,3	79,2	260,8	87,2	243,8	96,0	225,3	105,8	206,8	115,9
	15	10	284,4	80,0	268,2	87,9	250,9	96,8	232,1	106,6	213,1	116,6
	17	12	300,8	81,4	283,5	89,4	265,2	98,4	244,8	108,5	225,6	118,0
274	10	5	294,1	81,2	267,2	94,8	249,5	103,9	230,7	113,9	211,0	124,7
	12	7	300,4	88,0	283,7	96,1	265,3	105,2	245,1	115,3	224,4	126,0
	14	9	318,2	89,3	300,9	97,5	281,1	106,7	260,1	116,7	238,4	127,3
	15	10	328,0	89,9	309,4	98,2	289,5	107,5	267,8	117,5	246,2	127,8
	17	12	347,5	91,1	327,5	99,6	305,6	109,0	283,1	119,2	260,5	129,3
294	10	5	318,2	88,7	288,6	103,2	270,6	113,1	250,8	124,4	228,9	136,3
	12	7	324,6	95,9	306,7	104,7	287,4	114,9	265,8	126,0	243,2	137,8
	14	9	344,8	97,4	324,8	106,6	304,2	116,7	280,9	127,9	258,2	139,3
	15	10	354,3	98,3	334,7	107,4	312,4	117,6	289,0	128,9	265,8	140,2
	17	12	375,6	100,1	353,5	109,3	330,1	119,4	305,9	130,6	281,4	141,8
324	10	5	326,9	101,0	307,6	110,5	287,2	120,9	265,0	133,1	242,5	145,5
	12	7	346,4	102,8	326,3	112,3	304,4	122,9	280,9	135,1	257,5	147,2
	14	9	366,6	104,5	345,0	114,4	322,1	125,2	297,4	137,1	272,4	149,1
	15	10	377,1	105,6	354,6	115,3	330,9	126,2	306,0	138,2	280,4	150,0
	17	12	398,4	107,5	375,0	117,5	349,7	128,3	323,0	140,4	297,0	151,7

Tbs<sub>1</sub> Air inlet temperature (dry bulb)  
 Tw 1/2 Water inlet/outlet temperature  
 PF Cooling capacity  
 PA Total power input including pump

**Tab.19- Cooling capacities of LCE HQ reversible heat pumps, QUIET (Super Low Noise) version**

LCE . . . HQ	Tbs <sub>1</sub> (°C)		25		30		35		40		45	
	Tw <sub>1</sub>	Tw <sub>2</sub>	PF	PA	PF	PA	PF	PA	PF	PA	PF	PA
	°C		kW		kW		kW		kW		kW	
042	10	5	51,4	13,0	48,0	14,6	45,2	15,9	42,1	17,5	38,9	19,2
	12	7	55,1	13,1	51,1	14,8	48,0	16,2	44,8	17,7	41,3	19,5
	14	9	59,1	13,2	54,2	15,1	51,0	16,5	47,5	18,0	43,8	19,7
	15	10	61,1	13,2	55,9	15,3	52,4	16,6	48,8	18,2	45,0	19,9
	17	12	62,5	14,3	59,1	15,6	55,6	16,9	51,6	18,5	47,7	20,1
052	10	5	57,2	14,3	52,4	16,6	49,2	18,2	45,7	20,0	41,8	22,1
	12	7	61,7	14,3	55,8	16,9	52,3	18,5	48,4	20,4	44,4	22,3
	14	9	62,8	15,8	59,3	17,2	55,3	18,9	51,3	20,7	47,3	22,6
	15	10	64,9	15,9	61,0	17,4	56,9	19,1	52,8	20,9	48,6	22,8
	17	12	68,7	16,2	64,5	17,7	60,2	19,4	55,9	21,2	51,5	23,1
062	10	5	67,8	17,8	63,7	19,8	59,9	21,7	55,9	23,8	51,6	26,2
	12	7	72,6	17,8	67,7	20,1	63,7	22,0	59,5	24,1	54,8	26,6
	14	9	77,6	17,9	71,9	20,4	67,7	22,3	63,1	24,5	58,3	26,9
	15	10	80,1	17,9	74,0	20,5	69,7	22,5	64,9	24,7	60,0	27,1
	17	12	85,5	17,9	78,3	20,9	73,8	22,9	68,9	25,1	63,7	27,5
072	10	5	76,6	19,1	70,5	22,0	65,8	24,3	60,9	26,9	55,7	29,8
	12	7	81,9	19,1	74,8	22,3	69,9	24,7	64,7	27,3	59,2	30,2
	14	9	87,7	19,2	79,2	22,7	74,2	25,0	68,7	27,6	62,9	30,5
	15	10	86,6	20,9	81,6	22,9	76,4	25,2	70,6	27,9	64,9	30,6
	17	12	91,7	21,2	86,4	23,4	80,8	25,6	74,9	28,2	68,7	31,0
082	10	5	86,5	21,1	77,9	25,1	72,8	27,8	67,3	30,7	61,4	33,9
	12	7	88,0	23,2	82,7	25,6	77,4	28,2	71,6	31,1	65,6	34,2
	14	9	93,4	23,6	88,1	25,9	82,2	28,6	76,0	31,5	69,7	34,5
	15	10	96,3	23,7	90,5	26,2	84,7	28,8	78,3	31,8	72,1	34,6
	17	12	101,8	24,2	95,9	26,6	89,8	29,3	83,1	32,2	76,6	35,0
091	10	5	100,7	24,8	93,3	28,5	87,3	31,6	81,1	35,1	74,3	38,9
	12	7	108,1	24,8	99,1	28,9	92,9	32,0	86,2	35,5	79,2	39,3
	14	9	115,6	24,8	105,3	29,4	98,6	32,5	91,6	36,0	84,2	39,7
	15	10	119,5	24,8	108,3	29,6	101,6	32,7	94,2	36,2	86,8	40,0
	17	12	121,4	27,3	114,8	30,1	107,6	33,2	100,0	36,7	92,2	40,4
092	10	5	100,7	24,8	93,3	28,5	87,3	31,6	81,1	35,1	74,3	38,9
	12	7	108,1	24,8	99,1	28,9	92,9	32,0	86,2	35,5	79,2	39,3
	14	9	115,6	24,8	105,3	29,4	98,6	32,5	91,6	36,0	84,2	39,7
	15	10	119,5	24,8	108,3	29,6	101,6	32,7	94,2	36,2	86,8	40,0
	17	12	121,4	27,3	114,8	30,1	107,6	33,2	100,0	36,7	92,2	40,4
094	10	5	101,6	25,6	94,3	29,1	88,7	31,8	82,7	34,9	76,3	38,4
	12	7	108,9	25,7	100,2	29,6	94,3	32,3	87,8	35,5	81,0	38,9
	14	9	116,6	25,9	106,3	30,1	99,8	32,9	93,0	36,0	85,9	39,4
	15	10	115,6	28,0	109,3	30,5	102,8	33,3	95,6	36,4	88,2	39,7
	17	12	122,4	28,6	115,8	31,1	108,6	33,9	101,0	37,0	93,4	40,2
101	10	5	115,6	28,2	104,2	34,0	97,4	37,8	89,9	42,0	82,4	46,4
	12	7	117,6	31,1	110,7	34,5	103,4	38,4	95,6	42,5	87,5	47,0
	14	9	124,6	31,7	117,3	35,2	109,6	39,0	101,5	43,2	93,1	47,5
	15	10	128,0	32,0	120,8	35,4	112,9	39,3	104,3	43,6	96,0	47,8
	17	12	135,6	32,7	127,7	36,1	119,2	40,0	110,6	44,2	101,6	48,4

LCE . . . HQ	Tbs <sub>1</sub> (°C)		25		30		35		40		45	
	Tw <sub>1</sub>	Tw <sub>2</sub>	PF	PA	PF	PA	PF	PA	PF	PA	PF	PA
	°C		kW		kW		kW		kW		kW	
102	10	5	115,7	28,2	104,1	34,0	97,5	37,8	90,1	42,0	82,4	46,4
	12	7	117,4	31,1	110,7	34,5	103,5	38,4	95,7	42,5	87,5	47,0
	14	9	124,6	31,7	117,2	35,2	109,6	39,0	101,5	43,2	93,1	47,5
	15	10	128,0	32,0	120,8	35,4	112,8	39,3	104,3	43,6	96,0	47,8
	17	12	135,8	32,7	127,7	36,1	119,0	40,0	110,6	44,2	101,6	48,4
104	10	5	112,8	28,1	102,6	33,1	96,4	36,4	89,2	40,1	81,7	44,0
	12	7	115,7	30,8	109,0	33,8	102,2	37,1	94,6	40,8	86,9	44,6
	14	9	122,8	31,5	115,8	34,4	108,2	37,7	100,3	41,5	92,1	45,2
	15	10	126,6	31,8	119,1	34,8	111,4	38,1	103,0	41,8	94,8	45,6
	17	12	134,2	32,5	125,8	35,5	117,4	38,8	109,1	42,6	100,6	46,1
121	10	5	134,8	35,5	124,1	40,6	116,2	44,5	107,8	48,9	98,8	53,7
	12	7	144,5	35,5	132,0	41,1	123,6	45,0	114,6	49,5	105,0	54,3
	14	9	154,5	35,5	140,0	41,6	131,0	45,7	121,7	50,1	111,6	54,9
	15	10	152,7	38,4	144,1	42,0	135,0	46,0	125,1	50,5	115,0	55,2
	17	12	161,5	39,0	152,5	42,6	142,8	46,7	132,4	51,1	122,0	55,7
122	10	5	134,8	35,5	124,1	40,6	116,2	44,5	107,8	48,9	98,8	53,7
	12	7	144,5	35,5	132,0	41,1	123,6	45,0	114,6	49,5	105,0	54,3
	14	9	154,5	35,5	140,0	41,6	131,0	45,7	121,7	50,1	111,6	54,9
	15	10	152,7	38,4	144,1	42,0	135,0	46,0	125,1	50,5	115,0	55,2
	17	12	161,5	39,0	152,5	42,6	142,8	46,7	132,4	51,1	122,0	55,7
124	10	5	136,7	35,7	126,3	40,5	118,5	44,3	110,1	48,5	101,2	53,1
	12	7	146,4	35,8	133,9	41,2	125,7	45,0	116,8	49,3	107,8	53,8
	14	9	150,1	38,5	141,9	41,9	133,1	45,7	123,9	50,0	114,4	54,5
	15	10	154,3	38,8	146,2	42,2	137,1	46,1	127,5	50,4	117,5	54,9
	17	12	163,3	39,4	154,4	43,0	144,9	46,9	134,7	51,2	124,7	55,6
141	10	5	151,5	39,4	136,9	46,1	127,7	50,4	118,2	55,2	107,7	60,3
	12	7	154,0	42,9	145,2	46,8	135,5	51,1	125,3	56,0	114,4	61,0
	14	9	163,2	43,6	153,8	47,5	143,5	51,9	132,6	56,8	121,8	61,6
	15	10	168,2	43,8	158,5	47,8	147,9	52,2	136,5	57,2	125,2	61,9
	17	12	177,5	44,5	167,5	48,6	156,0	53,1	144,3	58,0	132,4	62,6
142	10	5	151,5	39,4	136,9	46,1	127,7	50,4	118,2	55,2	107,7	60,3
	12	7	154,0	42,9	145,2	46,8	135,5	51,1	125,3	56,0	114,4	61,0
	14	9	163,2	43,6	153,8	47,5	143,5	51,9	132,6	56,8	121,8	61,6
	15	10	168,2	43,8	158,5	47,8	147,9	52,2	136,5	57,2	125,2	61,9
	17	12	177,5	44,5	167,5	48,6	156,0	53,1	144,3	58,0	132,4	62,6
144	10	5	147,6	41,5	139,0	45,6	129,8	50,0	119,8	55,3	109,0	60,9
	12	7	156,7	42,2	147,5	46,3	137,6	50,8	126,9	56,1	115,8	61,5
	14	9	166,0	43,0	156,1	47,1	145,6	51,7	134,2	57,0	123,3	62,1
	15	10	170,7	43,4	160,7	47,5	149,7	52,1	138,2	57,4	126,7	62,5
	17	12	180,1	44,2	169,7	48,4	158,3	53,0	146,0	58,3	134,2	63,2
161	10	5	163,3	50,9	153,9	55,6	143,5	61,0	131,8	66,8	119,9	72,4
	12	7	173,5	51,8	162,9	56,7	151,9	62,0	139,2	67,8	127,2	73,3
	14	9	183,6	52,9	172,1	57,7	159,8	63,1	146,9	68,9	134,6	74,2
	15	10	188,9	53,4	176,7	58,3	164,0	63,6	151,2	69,3	138,5	74,7
	17	12	199,2	54,5	186,1	59,4	172,9	64,8	159,5	70,3	-	-
162	10	5	164,2	50,9	153,9	55,6	143,0	60,8	131,6	66,8	119,9	72,4
	12	7	173,6	51,9	162,8	56,6	151,5	62,0	139,2	67,8	127,2	73,3
	14	9	183,6	52,9	172,1	57,7	159,8	63,1	146,9	68,9	134,6	74,2
	15	10	188,8	53,4	176,8	58,3	164,2	63,6	151,2	69,3	138,5	74,7
	17	12	199,0	54,5	186,5	59,4	173,3	64,8	159,5	70,3	-	-



LCE . . . HQ	Tbs <sub>1</sub> (°C)		25		30		35		40		45	
	Tw <sub>1</sub>	Tw <sub>2</sub>	PF	PA	PF	PA	PF	PA	PF	PA	PF	PA
	°C		kW		kW		kW		kW		kW	
<b>164</b>	10	5	161,7	48,4	151,9	53,2	141,3	58,5	129,8	64,6	118,7	70,4
	12	7	171,8	49,2	161,2	54,0	150,1	59,4	138,3	65,4	126,4	71,1
	14	9	182,0	50,1	171,0	54,9	159,0	60,3	146,5	66,3	134,5	71,8
	15	10	187,0	50,6	176,0	55,4	163,6	60,9	150,8	66,7	138,8	72,1
	17	12	198,1	51,5	185,8	56,5	173,0	61,9	160,0	67,6	-	-
<b>194</b>	10	5	179,5	65,3	167,6	72,2	155,3	79,7	142,0	87,7	119,9	95,5
	12	7	190,1	66,6	177,6	73,4	164,4	81,1	150,5	89,0	119,9	95,5
	14	9	201,0	68,1	187,6	75,1	173,5	82,8	159,8	90,2	119,9	95,5
	15	10	206,4	68,8	192,5	75,9	178,3	83,6	164,0	90,9	119,9	95,5
	17	12	217,4	70,4	203,4	77,4	188,0	85,1	173,5	92,3	119,9	95,5
<b>214</b>	10	5	209,3	72,3	196,5	80,2	182,5	89,0	166,6	98,6	152,1	107,7
	12	7	221,7	73,9	207,8	81,9	192,6	90,8	176,6	100,3	161,1	109,3
	14	9	234,3	75,6	219,2	83,6	203,1	92,6	186,9	101,9	137,3	110,5
	15	10	240,4	76,4	225,3	84,5	208,6	93,5	192,1	102,8	137,3	110,5
	17	12	253,7	78,3	236,9	86,4	219,8	95,6	202,7	104,5	137,3	110,5
<b>244</b>	10	5	231,3	80,4	215,3	88,7	198,4	97,7	181,4	107,0	156,2	114,2
	12	7	244,1	82,2	227,4	90,5	209,6	99,7	191,7	108,7	156,2	114,2
	14	9	257,3	84,1	239,8	92,6	220,8	101,8	202,6	110,5	156,2	114,2
	15	10	264,1	85,1	245,6	93,6	226,6	102,8	208,2	111,4	156,2	114,2
	17	12	277,5	87,2	258,5	95,8	238,4	104,7	215,2	114,2	156,2	114,2
<b>274</b>	10	5	278,9	86,5	262,9	94,9	245,7	104,0	226,8	114,5	206,9	125,4
	12	7	296,3	87,8	279,1	96,3	260,7	105,6	240,7	116,1	220,0	126,8
	14	9	314,0	89,2	295,7	97,8	275,9	107,3	255,1	117,7	233,7	128,3
	15	10	322,7	90,0	303,7	98,6	283,8	108,2	262,3	118,7	240,2	129,1
	17	12	341,0	91,6	321,6	100,3	300,2	109,8	277,2	120,4	255,0	130,5
<b>294</b>	10	5	299,3	95,7	281,4	105,0	263,3	115,4	242,2	126,9	220,8	138,6
	12	7	317,2	97,4	298,9	106,9	278,7	117,3	256,6	128,9	234,3	140,2
	14	9	336,4	99,4	316,2	108,8	294,3	119,3	271,2	130,9	248,6	142,0
	15	10	346,1	100,2	324,9	109,7	302,5	120,4	278,6	131,9	255,7	142,7
	17	12	365,3	102,2	342,9	111,7	318,7	122,5	294,4	134,0	270,6	144,7
<b>324</b>	10	5	318,1	102,9	298,5	112,7	277,7	123,9	254,8	136,4	232,7	148,4
	12	7	337,0	104,8	315,8	114,9	293,8	126,1	270,3	138,5	247,0	150,3
	14	9	355,9	107,0	334,1	117,2	310,5	128,4	285,2	140,8	261,2	152,2
	15	10	365,2	108,2	343,4	118,2	318,8	129,7	293,6	141,8	268,9	153,1
	17	12	385,8	110,5	361,5	120,8	335,9	132,2	309,4	144,1	207,9	154,8

Tbs<sub>1</sub> Air inlet temperature (dry bulb)  
 Tw<sub>1/2</sub> Water inlet/outlet temperature  
 PT Heating capacity  
 PA Total power input including pump  
 RH Relative humidity

**Tab.20- Heating capacities of LCE HS reversible heat pumps, STANDARD version**

LCE . . . HS	Tbs <sub>1</sub> / RH		-7°C / 90%		-5°C / 90%		0°C / 90%		7°C / 88%		15°C / 80%		15°C / 80%	
	Tw <sub>1</sub>	Tw <sub>2</sub>	PT	PA	PT	PA	PT	PA	PT	PA	PT	PA	PT	PA
	°C		kW		kW		kW		kW		kW		kW	
062	30	35	51,1	14,9	52,0	14,9	60,2	15,2	72,3	15,6	75,8	15,7	87,2	15,9
	35	40	50,4	16,3	53,2	16,5	59,4	16,7	71,0	17,0	75,0	17,1	86,1	17,3
	40	45	50,0	18,0	52,7	18,1	58,6	18,3	69,7	18,7	73,9	18,8	-	-
	45	50	49,9	19,8	52,2	20,0	58,0	20,2	68,7	20,6	72,9	20,6	-	-
072	30	35	57,3	17,2	57,7	17,2	66,3	17,4	79,9	17,7	83,9	17,7	95,3	17,9
	35	40	56,2	19,0	57,3	19,0	66,1	19,2	78,5	19,5	82,9	19,6	93,9	19,7
	40	45	55,6	21,2	56,9	21,2	65,2	21,4	77,6	21,6	81,2	21,6	91,4	24,4
	45	50	55,6	23,6	58,8	23,6	64,4	23,7	76,0	23,9	80,5	24,0	-	-
082	30	35	67,5	20,3	63,2	20,1	72,7	20,1	87,6	20,2	92,1	20,2	104,0	20,3
	35	40	65,9	22,6	62,5	22,4	71,7	22,2	86,1	22,2	90,3	22,3	102,6	22,3
	40	45	64,9	25,2	62,2	24,8	71,4	24,7	84,5	24,6	89,3	24,5	100,9	24,6
	45	50	61,4	27,5	64,1	27,4	70,7	27,3	83,5	27,2	87,3	27,3	-	-
091	30	35	75,2	23,1	77,2	23,2	85,9	23,2	103,6	23,4	110,5	23,6	125,7	23,7
	35	40	73,5	25,5	76,4	25,6	85,4	25,7	102,6	25,9	108,6	25,9	123,0	26,2
	40	45	72,1	28,4	75,8	28,3	84,5	28,5	100,8	28,7	107,2	28,7	121,0	28,9
	45	50	72,5	31,4	75,9	31,5	83,7	31,5	98,9	31,8	105,0	31,7	118,1	31,9
092	30	35	75,2	23,1	77,2	23,2	85,9	23,2	103,6	23,4	110,5	23,6	125,7	23,7
	35	40	73,5	25,5	76,4	25,6	85,4	25,7	102,6	25,9	108,6	25,9	123,0	26,2
	40	45	72,1	28,4	75,8	28,3	84,5	28,5	100,8	28,7	107,2	28,7	121,0	28,9
	45	50	72,5	31,4	75,9	31,5	83,7	31,5	98,9	31,8	105,0	31,7	118,1	31,9
101	30	35	94,6	27,0	90,4	26,8	100,4	27,1	121,1	27,3	127,1	27,4	146,9	27,7
	35	40	88,1	29,6	89,6	29,7	100,1	30,0	119,2	30,3	124,9	30,4	143,8	30,6
	40	45	86,6	32,8	89,7	33,0	99,2	33,2	118,2	33,6	123,7	33,8	141,6	34,0
	45	50	85,6	36,6	89,5	36,7	99,0	37,1	116,1	37,4	123,0	37,5	138,1	37,8
102	30	35	85,5	26,7	88,3	26,8	99,6	27,1	121,1	27,3	127,1	27,4	146,9	27,7
	35	40	93,4	29,8	93,3	29,8	101,0	30,0	119,1	30,3	124,7	30,4	143,7	30,6
	40	45	88,2	33,0	90,5	33,0	99,6	33,2	118,2	33,6	123,7	33,8	141,6	34,0
	45	50	82,3	36,5	87,4	36,7	98,0	37,1	116,3	37,4	123,3	37,5	138,2	37,8
121	30,0	35,0	102,1	30,2	106,1	30,4	117,9	30,6	142,1	31,0	149,1	31,1	171,9	31,5
	35,0	40,0	99,9	33,3	105,1	33,4	117,4	33,7	139,7	34,1	148,7	34,2	169,6	34,5
	40,0	45,0	98,6	36,7	104,0	36,9	115,9	37,1	138,1	37,6	146,7	37,7	-	-
	45,0	50,0	98,1	40,4	104,0	40,7	114,4	40,9	135,2	41,5	143,3	41,7	-	-
122	30,0	35,0	102,1	30,2	106,1	30,4	117,9	30,6	142,1	31,0	149,1	31,1	171,9	31,5
	35,0	40,0	99,9	33,3	105,1	33,4	117,4	33,7	139,7	34,1	148,7	34,2	169,6	34,5
	40,0	45,0	98,6	36,7	104,0	36,9	115,9	37,1	138,1	37,6	146,7	37,7	163,2	42,3
	45,0	50,0	98,1	40,4	104,0	40,7	114,4	40,9	135,2	41,5	143,3	41,7	-	-
124	30,0	35,0	100,5	29,6	104,3	29,8	115,8	30,2	139,2	31,0	145,9	31,2	167,8	31,8
	35,0	40,0	98,3	32,5	103,3	32,6	114,4	33,1	136,8	33,9	145,6	34,1	165,8	34,6
	40,0	45,0	97,0	35,7	102,3	36,0	113,8	36,3	135,3	37,2	143,7	37,4	-	-
	45,0	50,0	96,4	39,3	101,4	39,6	112,3	40,0	132,6	40,9	140,5	41,2	-	-
141	30,0	35,0	118,3	33,4	114,0	33,5	131,6	33,9	158,3	34,4	164,7	34,5	189,6	34,9
	35,0	40,0	110,6	36,7	112,9	36,7	129,8	37,1	155,2	37,8	164,0	37,8	185,5	38,1
	40,0	45,0	108,4	40,2	112,2	40,5	128,7	40,9	152,7	41,3	160,3	41,5	177,2	46,1
	45,0	50,0	106,1	44,2	111,0	44,4	126,5	45,0	149,6	45,5	156,8	45,7	-	-

# Performance



LCE . . . HS	Tbs. / RH		-7°C / 90%		-5°C / 90%		0°C / 90%		7°C / 88%		15°C / 80%		15°C / 80%	
	Tw <sub>1</sub>	Tw <sub>2</sub>	PT	PA	PT	PA	PT	PA	PT	PA	PT	PA	PT	PA
	°C		kW		kW		kW		kW		kW		kW	
142	30,0	35,0	118,3	33,4	114,0	33,5	131,6	33,9	158,3	34,4	164,7	34,5	189,6	34,9
	35,0	40,0	110,6	36,7	112,9	36,7	129,8	37,1	155,2	37,8	164,0	37,8	185,5	38,1
	40,0	45,0	108,4	40,2	112,2	40,5	128,7	40,9	152,7	41,3	160,3	41,5	177,2	46,1
	45,0	50,0	106,1	44,2	111,0	44,4	126,5	45,0	149,6	45,5	156,8	45,7	-	-
144	30,0	35,0	115,8	32,8	111,0	32,6	128,6	33,0	154,9	33,5	159,8	33,7	185,7	34,3
	35,0	40,0	108,4	36,1	110,6	36,1	127,1	36,4	151,9	37,1	160,6	37,2	181,7	37,6
	40,0	45,0	106,7	40,0	110,3	40,2	125,9	40,5	149,1	40,9	157,1	41,1	173,7	45,9
	45,0	50,0	105,5	44,5	110,0	44,7	124,7	45,0	146,8	45,6	153,4	45,6	-	-
161	30,0	35,0	140,4	41,6	133,8	41,3	155,2	41,9	185,8	42,6	192,0	42,7	220,9	43,4
	35,0	40,0	141,7	45,8	132,8	45,6	151,2	46,0	180,8	46,6	188,2	46,8	217,2	47,6
	40,0	45,0	131,1	50,3	132,4	50,2	151,1	50,7	179,1	51,4	185,4	51,5	212,1	57,6
	45,0	50,0	128,4	55,4	132,0	55,4	151,0	55,9	177,3	56,7	182,3	56,7	-	-
162	30,0	35,0	141,5	40,3	133,6	40,1	154,5	40,8	185,8	41,5	191,9	41,6	221,0	42,2
	35,0	40,0	139,1	44,5	132,5	44,4	152,4	44,8	182,3	45,5	188,1	45,6	217,5	46,3
	40,0	45,0	130,8	49,0	132,4	48,9	151,4	49,3	179,1	50,0	185,4	50,1	211,8	56,1
	45,0	50,0	128,7	54,0	131,4	53,9	149,1	54,4	175,9	54,9	180,9	55,2	-	-
164	30,0	35,0	137,5	40,7	130,0	40,5	150,4	40,5	181,2	40,8	187,3	40,8	216,8	41,0
	35,0	40,0	134,2	45,6	128,4	44,9	148,3	44,7	178,1	44,8	183,8	44,9	212,0	45,1
	40,0	45,0	125,6	50,0	128,5	49,7	146,5	49,4	174,8	49,5	180,2	49,6	208,5	49,8
	45,0	50,0	125,0	55,3	128,7	55,1	146,0	54,9	171,4	54,8	180,4	54,9	-	-
174	30	35	136,4	44,1	143,8	44,0	165,7	44,2	194,1	44,4	207,1	44,5	242,8	43,0
	35	40	134,7	48,5	141,8	48,5	163,2	48,3	190,7	48,4	203,0	48,6	233,9	48,9
	40	45	133,8	53,3	140,7	53,2	160,9	53,0	186,8	53,2	198,9	53,1	228,4	53,3
	45	50	134,1	58,6	140,3	58,4	159,5	58,3	183,9	58,3	197,0	58,6	222,1	58,5
194	30	35	155,6	48,8	161,8	48,8	181,2	49,0	218,3	49,6	233,0	49,7	264,9	50,0
	35	40	152,5	53,7	160,6	53,8	178,8	54,1	214,8	54,2	228,5	54,6	259,0	54,9
	40	45	151,6	59,1	159,4	59,2	177,5	59,5	210,8	59,9	224,2	59,8	253,1	60,1
	45	50	151,9	65,3	159,6	65,5	176,4	65,6	207,7	65,8	220,7	66,3	249,8	66,6
214	30	35	168,6	54,4	175,3	54,4	199,3	54,8	241,7	55,6	256,0	55,6	290,6	56,2
	35	40	182,7	60,0	184,3	60,1	201,0	60,6	237,7	61,0	252,6	61,5	286,5	61,9
	40	45	172,2	66,2	179,7	66,3	196,9	66,9	233,8	67,7	248,6	67,6	280,4	68,1
	45	50	163,0	73,2	173,2	73,3	194,2	74,0	231,7	74,9	245,5	75,2	-	-
244	30	35	196,6	64,3	198,8	77,5	233,0	65,4	280,9	65,9	294,3	66,4	325,4	77,5
	35	40	194,7	70,8	198,8	77,5	230,2	71,5	275,5	72,7	289,0	72,6	-	-
	40	45	193,3	77,7	198,8	77,5	226,9	78,9	270,4	79,6	282,8	79,9	-	-
	45	50	192,2	85,6	198,8	77,5	223,7	87,0	264,5	87,8	278,1	88,1	-	-
274	30	35	222,1	72,2	235,3	72,6	263,7	73,3	317,3	74,2	338,1	74,5	383,5	75,0
	35	40	220,1	78,7	232,7	79,1	260,0	79,9	311,4	80,9	331,8	80,9	375,3	81,5
	40	45	217,9	86,3	230,1	86,5	256,1	87,3	305,2	88,2	323,8	88,9	365,5	89,2
	45	50	215,9	94,4	227,2	95,0	251,8	95,7	297,6	97,1	315,8	97,1	356,0	97,8
294	30	35	241,3	79,0	245,4	79,0	284,3	79,9	341,0	81,0	357,5	81,4	405,5	82,2
	35	40	236,8	86,4	242,1	86,4	277,7	87,2	333,0	88,5	349,1	88,9	399,0	89,8
	40	45	234,9	94,6	240,1	95,0	274,8	95,9	327,3	96,8	343,6	97,3	389,2	97,8
	45	50	233,3	104,1	239,6	104,2	272,4	105,2	321,0	106,3	337,1	106,8	383,3	107,3
324	30	35	272,2	85,4	261,3	85,0	302,3	86,0	363,0	87,8	381,0	88,0	432,0	89,0
	35	40	255,7	93,3	258,9	93,6	297,8	94,5	356,3	95,6	373,0	96,1	425,0	97,3
	40	45	251,2	102,4	257,7	102,8	293,4	103,6	348,6	104,7	367,2	105,3	424,4	105,7
	45	50	250,2	113,0	256,4	113,0	289,9	113,9	340,4	115,1	357,8	115,6	401,8	116,4

Tbs<sub>1</sub> Air inlet temperature (dry bulb)  
 Tw<sub>1/2</sub> Water inlet/outlet temperature  
 PT Heating capacity  
 PA Total power input including pump  
 RH Relative humidity

**Tab.21- Heating capacities of LCE HL reversible heat pumps, LOW NOISE version**

LCE . . . HL	Tbs <sub>1</sub> / RH		-7°C / 90%		-5°C / 90%		0°C / 90%		7°C / 88%		15°C / 80%		15°C / 80%	
	Tw <sub>1</sub>	Tw <sub>2</sub>	PT	PA	PT	PA	PT	PA	PT	PA	PT	PA	PT	PA
	°C		kW		kW		kW		kW		kW		kW	
042	30	35	37,5	11,7	38,5	11,8	45,0	12,0	54,6	12,3	57,5	12,4	-	-
	35	40	37,2	12,8	38,5	12,9	44,7	13,1	53,9	13,5	56,6	13,5	-	-
	40	45	36,8	14,2	38,6	14,3	44,4	14,4	53,0	14,8	55,5	14,9	-	-
	45	50	37,6	15,7	39,7	15,8	44,0	16,0	52,1	16,3	54,7	16,3	-	-
052	30	35	62,9	14,0	54,8	13,9	54,5	14,1	62,5	14,5	65,0	14,6	75,7	14,9
	35	40	56,0	15,4	50,0	15,3	52,9	15,5	61,7	15,9	65,0	16,0	74,0	16,3
	40	45	44,6	16,8	45,2	16,8	51,0	17,2	60,8	17,5	63,9	17,7	71,0	20,0
	45	50	40,9	18,6	42,4	18,8	49,8	19,0	59,8	19,5	62,6	19,5	-	-
062	30	35	51,5	15,1	52,7	15,1	61,0	15,4	73,3	15,8	77,4	15,9	87,7	16,1
	35	40	51,1	16,6	53,9	16,7	60,2	16,9	72,0	17,3	76,0	17,3	87,2	17,6
	40	45	50,7	18,3	53,4	18,5	59,6	18,7	70,8	19,0	75,5	19,1	85,1	19,3
	45	50	50,3	20,2	52,9	20,4	58,7	20,6	69,6	20,9	73,8	21,0	82,8	21,3
072	30	35	60,7	17,3	58,2	17,1	67,5	17,4	81,3	17,7	85,2	17,8	96,9	17,9
	35	40	57,0	19,0	57,7	19,1	66,6	19,2	79,8	19,5	83,6	19,6	95,4	19,8
	40	45	56,1	21,2	59,2	21,2	65,7	21,4	78,2	21,6	82,1	21,7	93,1	21,8
	45	50	56,0	23,7	58,8	23,7	64,9	23,8	76,6	24,0	80,5	24,1	91,8	24,2
082	30	35	68,2	20,6	64,6	20,3	74,1	20,3	89,4	20,4	93,9	20,4	106,9	20,5
	35	40	66,6	22,9	63,7	22,7	73,7	22,5	87,8	22,5	92,8	22,6	105,2	22,7
	40	45	62,2	25,2	63,4	25,2	72,7	25,0	86,8	24,9	91,0	24,9	102,9	25,0
	45	50	62,5	28,0	64,0	27,9	72,0	27,9	85,1	27,7	89,6	27,7	-	-
091	30	35	77,0	23,4	77,9	23,4	89,8	23,6	107,9	23,8	114,2	23,8	-	-
	35	40	75,2	25,9	77,0	26,0	89,0	26,1	106,4	26,3	112,0	26,4	-	-
	40	45	74,7	28,9	76,5	28,8	87,9	28,9	104,9	29,2	109,8	29,3	-	-
	45	50	74,7	32,0	76,3	32,1	86,9	32,3	102,8	32,4	107,8	32,5	-	-
092	30	35	77,0	23,4	77,9	23,4	89,8	23,6	107,9	23,8	114,2	23,8	-	-
	35	40	75,2	25,9	77,0	26,0	89,0	26,1	106,4	26,3	112,0	26,4	-	-
	40	45	74,7	28,9	76,5	28,8	87,9	28,9	104,9	29,2	109,8	29,3	-	-
	45	50	74,7	32,0	76,3	32,1	86,9	32,3	102,8	32,4	107,8	32,5	-	-
094	30	35	73,5	22,8	74,6	22,9	86,4	23,3	104,9	24,1	111,3	24,2	-	-
	35	40	72,6	25,1	74,4	25,1	86,0	25,6	103,6	26,2	109,5	26,6	-	-
	40	45	72,5	27,6	74,5	27,8	85,4	28,2	102,0	28,9	107,7	29,0	-	-
	45	50	73,2	30,7	74,6	30,7	85,2	31,1	100,8	31,7	105,6	31,9	-	-
101	30	35	91,9	27,0	87,1	26,8	100,8	27,1	120,4	27,5	127,6	27,5	145,0	27,7
	35	40	89,9	29,8	86,3	29,8	99,5	30,2	119,5	30,4	125,1	30,6	141,7	30,9
	40	45	84,6	33,0	85,7	33,2	98,5	33,6	117,3	34,0	122,9	33,9	139,5	38,2
	45	50	83,6	36,9	86,0	36,9	97,6	37,4	115,3	37,6	121,2	37,8	-	-
102	30	35	86,8	26,9	83,9	26,7	100,2	27,1	120,4	27,5	127,6	27,5	145,0	27,7
	35	40	96,8	29,9	89,6	29,9	100,7	30,2	119,3	30,4	125,0	30,5	141,6	30,9
	40	45	86,2	33,1	87,0	33,2	98,8	33,6	117,3	34,0	122,9	33,9	139,5	38,2
	45	50	81,5	36,7	83,7	36,9	97,2	37,4	115,5	37,6	121,5	37,8	-	-
104	30	35	120,3	26,7	107,2	26,6	103,8	26,9	118,8	27,7	124,6	27,8	142,5	28,4
	35	40	107,4	29,3	95,7	29,1	100,2	29,6	117,0	30,3	122,5	30,6	139,3	31,2
	40	45	85,3	32,1	85,7	32,1	96,8	32,6	115,0	33,6	120,5	33,7	136,9	38,0
	45	50	78,1	35,4	80,3	35,5	94,6	36,2	113,1	36,9	119,1	37,2	-	-

# Performance



LCE . . . HL	Tbs./ RH		-7°C / 90%		-5°C / 90%		0°C / 90%		7°C / 88%		15°C / 80%		15°C / 80%	
	Tw <sub>1</sub>	Tw <sub>2</sub>	PT	PA	PT	PA	PT	PA	PT	PA	PT	PA	PT	PA
	°C		kW		kW		kW		kW		kW		kW	
121	30	35	102,6	33,9	106,6	34,1	119,5	34,4	144,0	34,8	152,3	34,9	174,1	35,3
	35	40	100,4	37,2	105,6	37,3	118,0	37,6	141,5	38,1	150,6	38,2	170,5	38,5
	40	45	99,4	40,8	104,5	41,1	116,5	41,3	138,8	41,8	147,4	42,0	163,8	46,9
	45	50	98,9	44,9	104,5	45,1	114,9	45,4	135,8	46,0	143,9	46,2	-	-
122	30	35	102,6	33,9	106,6	34,1	119,5	34,4	144,0	34,8	152,3	34,9	174,1	35,3
	35	40	100,4	37,2	105,6	37,3	118,0	37,6	141,5	38,1	150,6	38,2	170,5	38,5
	40	45	99,4	40,8	104,5	41,1	116,5	41,3	138,8	41,8	147,4	42,0	163,8	46,9
	45	50	98,9	44,9	104,5	45,1	114,9	45,4	135,8	46,0	143,9	46,2	-	-
124	30	35	101,1	33,2	105,2	33,4	116,8	33,9	140,4	34,7	149,6	35,0	170,7	35,6
	35	40	99,2	36,4	104,2	36,5	116,3	37,0	139,1	37,9	148,0	38,1	167,2	38,7
	40	45	97,9	39,8	103,2	40,1	114,8	40,5	136,5	41,4	145,0	41,7	161,2	46,7
	45	50	97,3	43,7	102,3	44,0	113,3	44,4	133,7	45,4	141,7	45,7	-	-
141	30	35	116,4	37,6	119,5	37,6	132,8	38,0	159,8	38,5	170,4	38,7	193,1	39,1
	35	40	113,7	41,0	118,3	41,1	131,1	41,5	157,0	42,0	167,1	42,2	189,0	42,5
	40	45	111,5	44,8	117,0	45,1	130,2	45,4	153,8	46,0	163,4	46,2	185,5	46,6
	45	50	110,3	49,1	115,7	49,4	128,2	49,7	151,4	50,5	160,4	50,7	184,2	51,1
142	30	35	116,4	37,6	119,5	37,6	132,8	38,0	159,8	38,5	170,4	38,7	193,1	39,1
	35	40	113,7	41,0	118,3	41,1	131,1	41,5	157,0	42,0	167,1	42,2	189,0	42,5
	40	45	111,5	44,8	117,0	45,1	130,2	45,4	153,8	46,0	163,4	46,2	185,5	46,6
	45	50	110,3	49,1	115,7	49,4	128,2	49,7	151,4	50,5	160,4	50,7	184,2	51,1
144	30	35	113,8	36,7	116,8	36,7	129,8	37,0	156,4	37,6	164,0	37,8	189,1	38,5
	35	40	111,4	40,4	115,8	40,4	128,3	40,8	153,7	41,3	163,5	41,5	185,0	42,0
	40	45	109,7	44,6	115,0	44,8	127,7	45,2	150,7	45,6	160,0	45,8	181,7	46,2
	45	50	109,1	49,4	114,5	49,6	126,3	50,0	148,8	50,4	157,5	50,6	180,5	51,0
161	30	35	139,7	43,9	133,2	43,6	154,5	44,3	184,9	45,0	191,0	45,0	219,8	45,8
	35	40	141,0	48,2	132,6	48,0	151,1	48,4	179,9	49,0	187,3	49,2	216,1	50,0
	40	45	130,4	52,8	131,7	52,7	150,3	53,1	178,2	53,9	184,5	54,0	211,0	60,2
	45	50	127,5	58,0	131,3	58,0	150,2	58,4	176,4	59,3	181,4	59,3	-	-
162	30	35	140,8	43,7	133,0	43,6	153,7	44,2	184,9	45,0	190,9	45,1	219,9	45,8
	35	40	138,4	48,1	132,3	48,0	151,7	48,4	181,4	49,2	187,2	49,2	216,4	50,1
	40	45	130,2	52,8	131,8	52,7	150,7	53,1	178,2	53,9	184,5	54,0	210,8	60,2
	45	50	128,0	58,1	130,7	58,0	148,4	58,5	175,0	59,0	180,0	59,3	-	-
164	30	35	136,8	44,2	129,3	43,9	149,7	43,9	180,3	44,3	186,4	44,3	215,7	44,5
	35	40	133,5	49,3	127,7	48,6	147,5	48,3	177,2	48,5	182,9	48,6	210,9	48,8
	40	45	125,0	53,8	127,9	53,5	145,8	53,3	173,9	53,4	179,3	53,5	207,5	53,7
	45	50	124,3	59,5	128,0	59,2	145,3	59,1	170,5	58,9	179,5	59,0	202,0	59,2
194	30	35	156,6	49,9	155,8	49,8	180,3	50,0	217,1	50,6	228,2	50,6	259,6	50,9
	35	40	152,6	55,1	155,4	55,0	177,8	55,5	213,7	55,6	224,0	55,8	253,6	56,4
	40	45	150,9	60,9	154,4	61,1	177,3	61,4	209,7	61,8	221,4	61,7	249,9	62,0
	45	50	151,2	67,6	158,9	67,8	175,6	67,9	207,5	68,2	216,7	68,4	251,3	68,4
214	30	35	161,7	55,5	170,2	55,5	200,2	56,2	242,0	56,8	249,8	57,0	290,5	58,7
	35	40	174,1	61,6	178,1	61,6	200,0	62,2	237,4	62,9	244,8	63,1	290,5	58,7
	40	45	165,3	68,2	172,7	68,3	196,2	69,3	233,5	69,7	244,3	70,0	277,5	70,4
	45	50	161,2	75,7	166,5	75,8	192,8	76,5	229,4	77,5	241,2	77,7	270,3	78,2
244	30	35	199,2	65,8	200,3	65,8	232,0	66,5	279,3	67,3	288,3	67,5	-	-
	35	40	194,5	72,4	198,4	72,4	229,0	73,2	274,1	74,4	285,2	74,4	-	-
	40	45	190,1	82,2	198,2	80,2	226,7	81,1	269,1	81,8	279,3	82,2	-	-
	45	50	188,3	88,0	196,9	88,6	224,3	89,6	265,2	90,5	272,8	90,9	-	-
274	30	35	222,4	74,2	229,8	74,6	261,8	75,4	315,1	76,4	330,5	76,7	380,9	79,1
	35	40	219,5	81,2	232,1	81,6	258,3	82,5	309,4	83,6	327,0	83,6	380,9	79,1
	40	45	217,4	89,3	229,6	89,5	255,4	90,4	303,3	91,3	319,7	91,7	360,4	92,4
	45	50	215,4	98,0	226,6	98,6	252,1	99,3	298,0	100,8	311,6	100,8	352,5	101,6

# Performance



LCE . . . HL	Tbs <sub>1</sub> / RH		-7°C / 90%		-5°C / 90%		0°C / 90%		7°C / 88%		15°C / 80%		15°C / 80%	
	Tw <sub>1</sub>	Tw <sub>2</sub>	PT	PA	PT	PA	PT	PA	PT	PA	PT	PA	PT	PA
	°C		kW		kW		kW		kW		kW		kW	
<b>294</b>	30	35	252,7	80,8	243,9	80,8	282,7	81,7	339,2	83,0	350,4	83,0	406,6	84,2
	35	40	237,9	88,6	242,8	88,6	277,4	89,5	331,2	90,8	344,4	91,3	396,9	92,2
	40	45	233,2	97,3	240,7	97,7	275,5	98,7	325,6	99,7	338,4	99,8	380,6	111,3
	45	50	228,3	106,9	239,3	107,4	273,1	108,6	321,8	109,7	331,3	109,8	-	-
<b>324</b>	30	35	252,7	80,8	243,9	80,8	282,7	81,7	339,2	83,0	350,4	83,0	406,6	84,2
	35	40	237,9	88,6	242,8	88,6	277,4	89,5	331,2	90,8	344,4	91,3	396,9	92,2
	40	45	233,2	97,3	240,7	97,7	275,5	98,7	325,6	99,7	338,4	99,8	380,6	111,3
	45	50	228,3	106,9	239,3	107,4	273,1	108,6	321,8	109,7	331,3	109,8	-	-

Tbs<sub>1</sub> Air inlet temperature (dry bulb)  
 Tw<sub>1/2</sub> Water inlet/outlet temperature  
 PT Heating capacity  
 PA Total power input including pump  
 RH Relative humidity

**Tab.22- Heating capacities of LCE HQ reversible heat pumps, QUIET (Super Low Noise) version**

LCE . . . HQ	Tbs <sub>1</sub> / RH		-7°C / 90%		-5°C / 90%		0°C / 90%		7°C / 88%		15°C / 80%		15°C / 80%	
	Tw <sub>1</sub>	Tw <sub>2</sub>	PT	PA	PT	PA	PT	PA	PT	PA	PT	PA	PT	PA
	°C		kW		kW		kW		kW		kW		kW	
042	30	35	37,5	11,7	38,5	11,8	45,0	12,0	54,6	12,3	57,5	12,4	-	-
	35	40	37,2	12,8	38,5	12,9	44,7	13,1	53,9	13,5	56,6	13,5	-	-
	40	45	36,8	14,2	38,6	14,3	44,4	14,4	53,0	14,8	55,5	14,9	-	-
	45	50	37,6	15,7	39,7	15,8	44,0	16,0	52,1	16,3	54,7	16,3	-	-
052	30	35	62,9	14,0	54,8	13,9	54,5	14,1	62,5	14,5	65,0	14,6	75,7	14,9
	35	40	56,0	15,4	50,0	15,3	52,9	15,5	61,7	15,9	65,0	16,0	74,0	16,3
	40	45	44,6	16,8	45,2	16,8	51,0	17,2	60,8	17,5	63,9	17,7	71,0	20,0
	45	50	40,9	18,6	42,4	18,8	49,8	19,0	59,8	19,5	62,6	19,5	71,0	20,0
062	30	35	51,5	15,1	52,7	15,1	61,0	15,4	73,3	15,8	77,4	15,9	87,7	16,1
	35	40	51,1	16,6	53,9	16,7	60,2	16,9	72,0	17,3	76,0	17,3	87,2	17,6
	40	45	50,7	18,3	53,4	18,5	59,6	18,7	70,8	19,0	75,5	19,1	85,1	19,3
	45	50	50,3	20,2	52,9	20,4	58,7	20,6	69,6	20,9	73,8	21,0	82,8	21,3
072	30	35	60,7	17,3	58,2	17,1	67,5	17,4	81,3	17,7	85,2	17,8	96,9	17,9
	35	40	57,0	19,0	57,7	19,1	66,6	19,2	79,8	19,5	83,6	19,6	95,4	19,8
	40	45	56,1	21,2	59,2	21,2	65,7	21,4	78,2	21,6	82,1	21,7	93,1	21,8
	45	50	56,0	23,7	58,8	23,7	64,9	23,8	76,6	24,0	80,5	24,1	91,8	24,2
082	30	35	68,2	20,6	64,6	20,3	74,1	20,3	89,4	20,4	93,9	20,4	106,9	20,5
	35	40	66,6	22,9	63,7	22,7	73,7	22,5	87,8	22,5	92,8	22,6	105,2	22,7
	40	45	62,2	25,2	63,4	25,2	72,7	25,0	86,8	24,9	91,0	24,9	102,9	25,0
	45	50	62,5	28,0	64,0	27,9	72,0	27,9	85,1	27,7	89,6	27,7	-	-
091	30	35	77,0	23,4	77,9	23,4	89,8	23,6	107,9	23,8	114,2	23,8	-	-
	35	40	75,2	25,9	77,0	26,0	89,0	26,1	106,4	26,3	112,0	26,4	-	-
	40	45	74,7	28,9	76,5	28,8	87,9	28,9	104,9	29,2	109,8	29,3	-	-
	45	50	74,7	32,0	76,3	32,1	86,9	32,3	102,8	32,4	107,8	32,5	-	-
092	30	35	77,0	23,4	77,9	23,4	89,8	23,6	107,9	23,8	114,2	23,8	-	-
	35	40	75,2	25,9	77,0	26,0	89,0	26,1	106,4	26,3	112,0	26,4	-	-
	40	45	74,7	28,9	76,5	28,8	87,9	28,9	104,9	29,2	109,8	29,3	-	-
	45	50	74,7	32,0	76,3	32,1	86,9	32,3	102,8	32,4	107,8	32,5	-	-
094	30	35	73,5	22,8	74,6	22,9	86,4	23,3	104,9	24,1	111,3	24,2	-	-
	35	40	72,6	25,1	74,4	25,1	86,0	25,6	103,6	26,2	109,5	26,6	-	-
	40	45	72,5	27,6	74,5	27,8	85,4	28,2	102,0	28,9	107,7	29,0	-	-
	45	50	73,2	30,7	74,6	30,7	85,2	31,1	100,8	31,7	105,6	31,9	-	-
101	30	35	91,9	27,0	87,1	26,8	100,8	27,1	120,4	27,5	127,6	27,5	145,0	27,7
	35	40	89,9	29,8	86,3	29,8	99,5	30,2	119,5	30,4	125,1	30,6	141,7	30,9
	40	45	84,6	33,0	85,7	33,2	98,5	33,6	117,3	34,0	122,9	33,9	139,5	38,2
	45	50	83,6	36,9	86,0	36,9	97,6	37,4	115,3	37,6	121,2	37,8	139,5	38,2
102	30	35	86,8	26,9	83,9	26,7	100,2	27,1	120,4	27,5	127,6	27,5	145,0	27,7
	35	40	96,8	29,9	89,6	29,9	100,7	30,2	119,3	30,4	125,0	30,5	141,6	30,9
	40	45	86,2	33,1	87,0	33,2	98,8	33,6	117,3	34,0	122,9	33,9	139,5	38,2
	45	50	81,5	36,7	83,7	36,9	97,2	37,4	115,5	37,6	121,5	37,8	139,5	38,2
104	30	35	120,3	26,7	107,2	26,6	103,8	26,9	118,8	27,7	124,6	27,8	142,5	28,4
	35	40	107,4	29,3	95,7	29,1	100,2	29,6	117,0	30,3	122,5	30,6	139,3	31,2
	40	45	85,3	32,1	85,7	32,1	96,8	32,6	115,0	33,6	120,5	33,7	136,9	38,0
	45	50	78,1	35,4	80,3	35,5	94,6	36,2	113,1	36,9	119,1	37,2	136,9	38,0

# Performance



LCE . . . HQ	Tbs./ RH		-7°C / 90%		-5°C / 90%		0°C / 90%		7°C / 88%		15°C / 80%		15°C / 80%	
	Tw <sub>1</sub>	Tw <sub>2</sub>	PT	PA	PT	PA	PT	PA	PT	PA	PT	PA	PT	PA
	°C		kW		kW		kW		kW		kW		kW	
121	30	35	99,3	31,7	100,6	31,8	116,5	32,1	140,3	32,5	146,0	32,6	168,3	33,0
	35	40	96,9	34,8	99,6	34,8	115,0	35,1	137,8	35,5	143,3	35,7	164,8	35,9
	40	45	95,1	38,1	99,2	38,1	113,8	38,7	135,2	39,0	140,3	39,2	160,6	39,4
	45	50	95,9	41,8	98,4	42,1	112,2	42,5	133,2	42,9	139,1	43,1	157,3	43,4
122	30	35	99,3	31,7	100,6	31,8	116,5	32,1	140,3	32,5	146,0	32,6	168,3	33,0
	35	40	96,9	34,8	99,6	34,8	115,0	35,1	137,8	35,5	143,3	35,7	164,8	35,9
	40	45	95,1	38,1	99,2	38,1	113,8	38,7	135,2	39,0	140,3	39,2	160,6	39,4
	45	50	95,9	41,8	98,4	42,1	112,2	42,5	133,2	42,9	139,1	43,1	157,3	43,4
124	30	35	97,4	31,1	98,9	31,2	114,4	31,7	137,5	32,5	142,9	32,6	164,4	33,2
	35	40	95,6	33,9	98,0	34,0	112,9	34,6	134,9	35,5	140,3	35,5	161,0	36,1
	40	45	93,6	37,1	97,1	37,3	111,3	37,9	132,5	38,6	137,5	38,8	157,2	39,4
	45	50	94,3	40,7	96,3	40,9	109,7	41,6	130,2	42,3	136,4	42,6	153,6	43,1
141	30	35	116,7	35,6	112,0	35,8	129,8	36,1	156,1	36,6	161,1	36,8	185,5	37,2
	35	40	109,4	39,0	110,9	39,0	128,0	39,4	153,1	40,1	158,0	40,1	183,0	40,4
	40	45	106,9	42,6	109,9	42,7	125,9	43,3	150,0	43,7	155,7	43,9	178,2	44,2
	45	50	104,9	46,6	109,0	46,9	124,3	47,5	146,5	48,0	151,8	48,2	173,0	48,5
142	30	35	116,7	35,6	112,0	35,8	129,8	36,1	156,1	36,6	161,1	36,8	185,5	37,2
	35	40	109,4	39,0	110,9	39,0	128,0	39,4	153,1	40,1	158,0	40,1	183,0	40,4
	40	45	106,9	42,6	109,9	42,7	125,9	43,3	150,0	43,7	155,7	43,9	178,2	44,2
	45	50	104,9	46,6	109,0	46,9	124,3	47,5	146,5	48,0	151,8	48,2	173,0	48,5
144	30	35	114,2	35,1	109,5	34,8	126,9	35,2	152,8	35,8	157,7	36,0	181,7	36,6
	35	40	107,2	38,4	108,7	38,4	125,3	38,7	149,8	39,5	154,7	39,5	179,2	39,9
	40	45	105,2	42,4	108,0	42,5	123,7	42,9	147,1	43,3	152,6	43,5	174,5	43,9
	45	50	104,2	46,9	108,1	47,1	122,2	47,5	143,9	47,8	149,1	48,0	169,6	48,4
161	30	35	135,9	41,7	129,6	41,5	149,1	42,1	178,5	42,8	184,4	42,8	213,9	43,5
	35	40	137,2	45,8	128,2	45,7	145,9	46,1	175,1	46,6	180,7	46,8	208,6	47,6
	40	45	133,4	50,3	127,2	50,1	145,2	50,5	172,8	51,2	178,1	51,3	203,9	51,9
	45	50	124,3	55,1	127,3	55,1	145,1	55,5	170,5	56,3	176,6	56,3	199,8	56,9
162	30	35	137,0	41,6	129,2	41,4	148,5	41,9	178,4	42,8	184,3	42,8	214,0	43,5
	35	40	134,7	45,7	128,3	45,6	147,6	46,0	176,5	46,8	182,1	46,8	209,0	47,6
	40	45	132,6	50,3	127,3	50,1	145,5	50,5	172,8	51,2	178,1	51,3	203,8	51,9
	45	50	124,6	55,1	127,2	55,1	143,9	55,5	169,1	56,1	175,1	56,3	199,3	56,9
164	30	35	134,2	42,0	126,9	41,8	145,6	41,8	175,6	41,9	181,3	42,1	209,8	42,3
	35	40	130,9	46,8	125,3	46,1	144,1	45,9	172,5	46,0	178,1	46,0	206,9	46,4
	40	45	123,0	51,1	124,5	50,9	143,0	50,6	170,0	50,7	175,8	50,8	202,7	56,4
	45	50	122,0	56,4	125,1	56,2	141,5	56,1	167,3	55,9	172,4	55,8	202,7	56,4
194	30	35	163,7	49,4	154,6	49,1	173,6	49,3	209,4	49,7	216,2	49,9	250,1	50,2
	35	40	160,1	54,6	150,7	54,2	172,9	54,4	207,6	54,8	212,7	54,8	244,8	55,3
	40	45	157,5	60,3	150,1	59,9	171,2	60,2	204,1	60,6	210,3	60,8	241,1	61,1
	45	50	156,7	66,6	150,3	66,6	170,9	66,9	201,9	67,1	207,7	67,4	236,8	67,7
214	30	35	166,2	54,5	159,3	54,4	195,4	55,1	234,4	55,7	243,9	55,9	275,5	66,3
	35	40	185,3	60,5	170,6	60,4	194,8	61,0	230,9	61,6	239,0	61,9	275,5	66,3
	40	45	173,6	66,5	165,3	66,8	192,0	67,6	228,1	68,4	235,3	68,3	275,5	66,3
	45	50	152,4	73,8	160,2	74,2	188,3	75,0	224,2	75,9	232,3	76,2	275,5	66,3
244	30	35	205,2	64,4	195,4	64,5	225,6	65,1	271,7	66,0	280,4	66,2	323,3	67,0
	35	40	201,1	70,8	190,8	70,9	222,8	71,8	267,0	72,7	275,3	73,0	316,5	73,5
	40	45	197,3	78,2	187,1	78,2	219,7	79,5	261,8	80,2	269,7	80,5	307,1	89,7
	45	50	194,7	86,2	187,7	86,3	218,4	87,8	256,2	88,7	265,5	89,1	-	-
274	30	35	217,4	72,9	220,4	73,4	255,3	74,2	307,2	75,2	317,3	75,2	365,5	76,1
	35	40	212,9	80,0	218,2	80,5	251,8	81,4	301,5	82,5	311,2	82,5	357,7	83,2
	40	45	208,0	88,3	216,0	88,4	248,0	89,4	295,6	90,3	304,4	90,7	341,7	101,6
	45	50	204,1	97,0	214,3	97,6	243,8	98,5	288,1	100,0	299,1	100,0	-	-



# Performance



LCE . . . HQ	Tbs <sub>1</sub> / RH		-7°C / 90%		-5°C / 90%		0°C / 90%		7°C / 88%		15°C / 80%		15°C / 80%	
	Tw <sub>1</sub>	Tw <sub>2</sub>	PT	PA	PT	PA	PT	PA	PT	PA	PT	PA	PT	PA
	°C		kW		kW		kW		kW		kW		kW	
<b>294</b>	30	35	246,0	79,7	237,4	79,8	275,1	80,7	330,1	82,0	341,0	82,0	392,5	83,2
	35	40	232,3	87,7	234,5	87,7	268,9	88,6	322,3	90,0	332,5	90,4	383,2	91,3
	40	45	226,9	96,5	232,5	96,9	266,1	97,9	316,9	98,9	326,8	99,0	371,1	110,7
	45	50	222,7	106,2	232,0	106,8	263,9	107,9	311,0	109,1	322,4	109,1	-	-
<b>324</b>	30	35	265,3	86,5	252,6	86,1	292,2	87,2	350,8	89,1	359,4	89,2	417,6	90,4
	35	40	260,8	95,6	250,3	95,3	287,9	96,2	344,5	97,4	355,0	97,9	407,7	99,2
	40	45	245,5	104,9	248,3	105,2	283,7	106,0	337,1	107,2	347,1	107,7	398,7	119,8
	45	50	240,6	116,2	248,1	116,1	280,4	117,1	329,3	118,3	341,6	118,4	-	-

## Calculation Factors

### Integrated heating capacities

In the heat pump operation (heating mode), the actual heating capacities of units may be lower than the values shown in the table, due to defrosting cycles. To obtain the actual heating capacity, multiply the capacity values by the corrective coefficients given in the table at right.

Control	Air temperature- dry bulb (°C)			
	- 5	0	5	> 5
<b>μ chiller2</b>	0,89	0,88	0,94	1
<b>PCO</b>	0,91	0,9	0,94	1

### Change in operating parameters with $\Delta T$ other than 5°C

After identifying the unit's performance in the terms of the desired outlet water temperature, correct the value by multiplying it by the corrective coefficients given in the table at right.

Water temperature differential other than 5 °C						
Water temperature differential	3	4	5	6	7	8
<b>Capacity correction factor</b>	0,975	0,990	1,000	1,015	1,030	1,040
<b>Power input correction factor</b>	1,000	1,000	1,000	1,000	1,000	1,000
<b>Water flow rate correction factor</b>	1,630	1,240	1,000	0,850	0,740	0,650
<b>Pressure drop correction factor</b>	2,640	1,530	1,000	0,720	0,540	0,420

### Water and glycol mixture

Based on the minimum outlet water temperature, you can derive the percentage of ethylene glycol and the corrective coefficient given in the table at right.

**Warning:** The use of propylene glycol is not admitted with standard pumps. For further information, contact the manufacturer.



Operation with water-ethylene glycol mixtures					
Percentage of glycol	0 %	10 %	20 %	30 %	40 %
<b>Minimum temperature of water produced</b>	5°C	2	-5°C	-10°C	-15
<b>Mixture freezing temperature (°C)</b>	0	-4	-14°C	-18°C	-24°C
<b>Capacity correction factor</b>	1,000	0,998	0,994	0,989	0,983
<b>Water flow rate correction factor</b>	1,000	1,047	1,094	1,140	1,199
<b>Pressure drop correction factor</b>	1,000	1,157	1,352	1,585	1,860

## Sound Level

### Legend

- L<sub>PA</sub>** Total sound pressure level, weighted A, measured in an open field, at a distance of 10 m, with a directivity factor of 2.
- L<sub>W</sub>** Sound power level by octave band, not weighted.
- L<sub>WA</sub>** Total sound power level, weighted A.

LCE . . . S	LCE S Sound level, STANDARD version								
	L <sub>W</sub>							L <sub>WA</sub> dB(A)	L <sub>PA</sub> dB(A)
	125 Hz	250 Hz	500 Hz	1000 Hz	2000 Hz	4000 Hz	8000 Hz		
	dB								
042									
052									
062	78,7	82,5	76,5	75,9	69,0	62,7	61,2	80,0	52,0
072	78,7	82,5	76,5	75,9	69,0	62,7	61,2	80,0	52,0
082	78,7	82,5	76,5	75,9	69,0	62,7	61,2	80,0	52,0
091	80,2	84,0	78,0	77,4	70,5	64,2	62,7	81,5	53,5
092	80,2	84,0	78,0	77,4	70,5	64,2	62,7	81,5	53,5
101	80,2	84,0	78,0	77,4	70,5	64,2	62,7	81,5	53,5
102	80,2	84,0	78,0	77,4	70,5	64,2	62,7	81,5	53,5
121	80,7	84,5	78,5	77,9	71,0	64,7	63,2	82,0	54,0
122	80,7	84,5	78,5	77,9	71,0	64,7	63,2	82,0	54,0
124	80,7	84,5	78,5	77,9	71,0	64,7	63,2	82,0	54,0
141	80,7	84,5	78,5	77,9	71,0	64,7	63,2	82,0	54,0
142	80,7	84,5	78,5	77,9	71,0	64,7	63,2	82,0	54,0
144	80,7	84,5	78,5	77,9	71,0	64,7	63,2	82,0	54,0
161	80,7	84,5	78,5	77,9	71,0	64,7	63,2	82,0	54,0
162	80,7	84,5	78,5	77,9	71,0	64,7	63,2	82,0	54,0
164	80,7	84,5	78,5	77,9	71,0	64,7	63,2	82,0	54,0
174	81,5	85,3	79,3	78,7	71,8	65,5	64,0	82,8	54,8
194	81,5	85,3	79,3	78,7	71,8	65,5	64,0	82,8	54,8
214	81,5	85,3	79,3	78,7	71,8	65,5	64,0	82,8	54,8
244	81,5	85,3	79,3	78,7	71,8	65,5	64,0	82,8	54,8
274	82,7	86,5	80,5	79,9	73,0	66,7	65,2	84,0	56,0
294	82,7	86,5	80,5	79,9	73,0	66,7	65,2	84,0	56,0
324	82,7	86,5	80,5	79,9	73,0	66,7	65,2	84,0	56,0

## Legend

- L<sub>PA</sub>** Total sound pressure level, weighted A, measured in an open field, at a distance of 10 m, with a directivity factor of 2.
- L<sub>W</sub>** Sound power level by octave band, not weighted.
- L<sub>WA</sub>** Total sound power level, weighted A.

LCE . . . L	LCE L Sound level, LOW NOISE version								
	L <sub>W</sub>							L <sub>WA</sub> dB(A)	L <sub>PA</sub> dB(A)
	125 Hz	250 Hz	500 Hz	1000 Hz	2000 Hz	4000 Hz	8000 Hz		
	dB								
042	68,0	73,6	68,0	64,0	56,7	53,6	52,6	70,0	42,0
052	68,0	73,6	68,0	64,0	56,7	53,6	52,6	70,0	42,0
062	70,0	75,6	70,0	66,0	58,7	55,6	54,6	72,0	44,0
072	70,0	75,6	70,0	66,0	58,7	55,6	54,6	72,0	44,0
082	70,0	75,6	70,0	66,0	58,7	55,6	54,6	72,0	44,0
091	71,0	76,6	71,0	67,0	59,7	56,6	55,6	73,0	45,0
092	71,0	76,6	71,0	67,0	59,7	56,6	55,6	73,0	45,0
094	71,0	76,6	71,0	67,0	59,7	56,6	55,6	73,0	45,0
101	71,0	76,6	71,0	67,0	59,7	56,6	55,6	73,0	45,0
102	71,0	76,6	71,0	67,0	59,7	56,6	55,6	73,0	45,0
104	71,0	76,6	71,0	67,0	59,7	56,6	55,6	73,0	45,0
121	75,0	80,6	75,0	71,0	63,7	60,6	59,6	77,0	49,0
122	75,0	80,6	75,0	71,0	63,7	60,6	59,6	77,0	49,0
124	75,0	80,6	75,0	71,0	63,7	60,6	59,6	77,0	49,0
141	75,0	80,6	75,0	71,0	63,7	60,6	59,6	77,0	49,0
142	75,0	80,6	75,0	71,0	63,7	60,6	59,6	77,0	49,0
144	75,0	80,6	75,0	71,0	63,7	60,6	59,6	77,0	49,0
161	75,0	80,6	75,0	71,0	63,7	60,6	59,6	77,0	49,0
162	75,0	80,6	75,0	71,0	63,7	60,6	59,6	77,0	49,0
164	75,0	80,6	75,0	71,0	63,7	60,6	59,6	77,0	49,0
194	75,0	80,6	75,0	71,0	63,7	60,6	59,6	77,0	49,0
214	75,0	80,6	75,0	71,0	63,7	60,6	59,6	77,0	49,0
244	76,0	81,6	76,0	72,0	64,7	61,6	60,6	78,0	50,0
274	77,0	82,6	77,0	73,0	65,7	62,6	61,6	79,0	51,0
294	77,0	82,6	77,0	73,0	65,7	62,6	61,6	79,0	51,0
324	77,0	82,6	77,0	73,0	65,7	62,6	61,6	79,0	51,0

## Legend

- L<sub>PA</sub>** Total sound pressure level, weighted A, measured in an open field, at a distance of 10 m, with a directivity factor of 2.
- L<sub>W</sub>** Sound power level by octave band, not weighted.
- L<sub>WA</sub>** Total sound power level, weighted A.

LCE . . . Q	LCE Q Sound level, QUIET version								
	L <sub>W</sub>							L <sub>WA</sub> dB(A)	L <sub>PA</sub> dB(A)
	125 Hz	250 Hz	500 Hz	1000 Hz	2000 Hz	4000 Hz	8000 Hz		
	dB								
042	66,0	70,8	65,2	60,0	53,9	52,4	50,2	67,0	39,0
052	66,0	70,8	65,2	60,0	53,9	52,4	50,2	67,0	39,0
062	68,0	72,8	67,2	62,0	55,9	54,4	52,2	69,0	41,0
072	68,0	72,8	67,2	62,0	55,9	54,4	52,2	69,0	41,0
082	68,0	72,8	67,2	62,0	55,9	54,4	52,2	69,0	41,0
091	69,0	73,8	68,2	63,0	56,9	55,4	53,2	70,0	42,0
092	69,0	73,8	68,2	63,0	56,9	55,4	53,2	70,0	42,0
094	69,0	73,8	68,2	63,0	56,9	55,4	53,2	70,0	42,0
101	69,0	73,8	68,2	63,0	56,9	55,4	53,2	70,0	42,0
102	69,0	73,8	68,2	63,0	56,9	55,4	53,2	70,0	42,0
104	69,0	73,8	68,2	63,0	56,9	55,4	53,2	70,0	42,0
121	68,0	72,8	67,2	62,0	55,9	54,4	52,2	69,0	41,0
122	68,0	72,8	67,2	62,0	55,9	54,4	52,2	69,0	41,0
124	68,0	72,8	67,2	62,0	55,9	54,4	52,2	69,0	41,0
141	68,0	72,8	67,2	62,0	55,9	54,4	52,2	69,0	41,0
142	68,0	72,8	67,2	62,0	55,9	54,4	52,2	69,0	41,0
144	68,0	72,8	67,2	62,0	55,9	54,4	52,2	69,0	41,0
161	68,0	72,8	67,2	62,0	55,9	54,4	52,2	69,0	41,0
162	68,0	72,8	67,2	62,0	55,9	54,4	52,2	69,0	41,0
164	68,0	72,8	67,2	62,0	55,9	54,4	52,2	69,0	41,0
194	68,0	72,8	67,2	62,0	55,9	54,4	52,2	69,0	41,0
214	68,0	72,8	67,2	62,0	55,9	54,4	52,2	69,0	41,0
244	68,0	72,8	67,2	62,0	55,9	54,4	52,2	69,0	41,0
274	69,0	73,8	68,2	63,0	56,9	55,4	53,2	70,0	42,0
294	69,0	73,8	68,2	63,0	56,9	55,4	53,2	70,0	42,0
324	69,0	73,8	68,2	63,0	56,9	55,4	53,2	70,0	42,0

## Operating Limits

The graphs below illustrate the operating limits of the units (in the case of continuous operation) in relation to the outlet water temperature and outdoor air temperature.

Operating limits	Chiller		Heat pump	
	Min.	Max.	Min.	Max.
Inlet water temperature (°C)	8	20 <sup>1</sup>	25	42
Outlet water temperature (°C)	5	15	28	50 <sup>2</sup>
Thermal differential of water (°C)	3	8	3	8
Outdoor air temperature (°C)	15 <sup>3</sup>	45	- 5	20

- 1 For transitory periods (e.g. equipment start up) values up to 25 °C are allowed.
- 2 Value that may be reached only for outdoor air temperatures exceeding 0°C.
- 3 With condensation control: Outdoor air  $T_{min}$  -15 °C.



The units are designed to work with water and air temperatures falling within the range defined by the operating limits. Attempting to operate the units beyond these limits could cause irreparable damage to the units themselves.

### Operating limits in chiller mode

- CC Condensation control
- VTE Electronic valve
- STD Standard

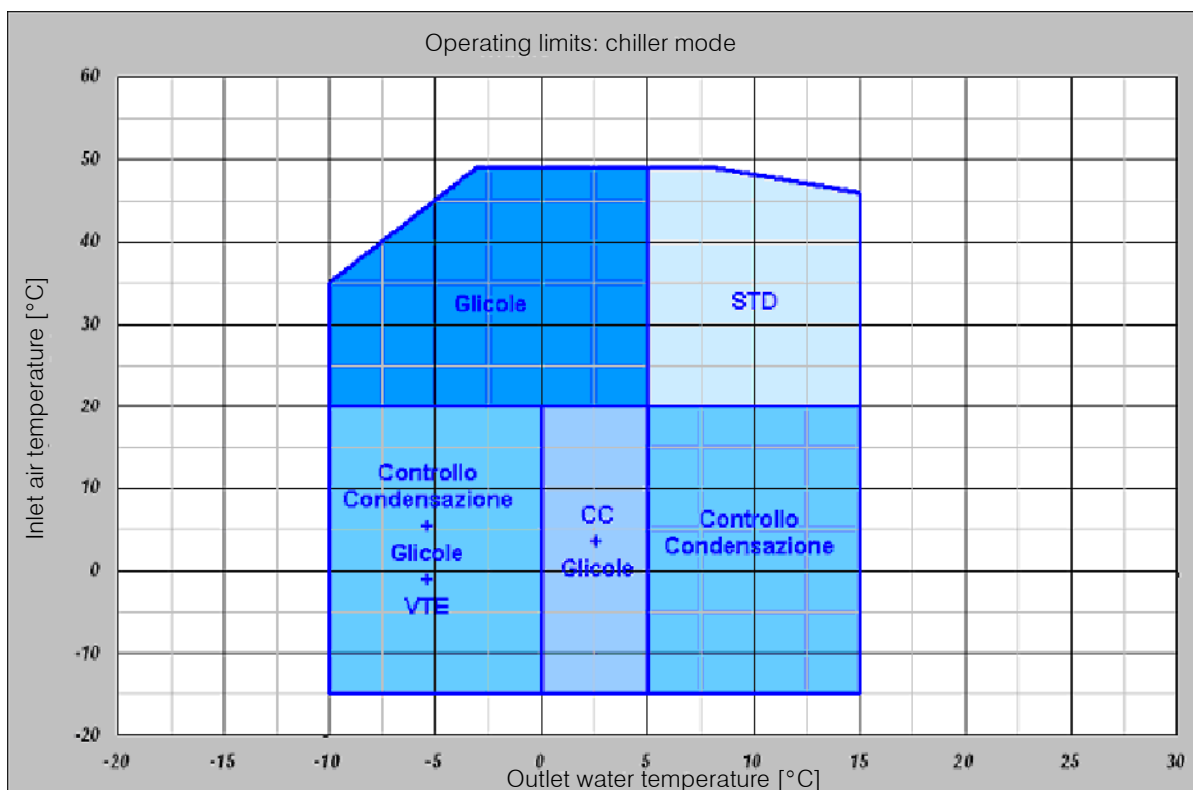

# Operating Limits



## Operating limits in heat pump mode

VTE            Electronic valve  
STD            Standard

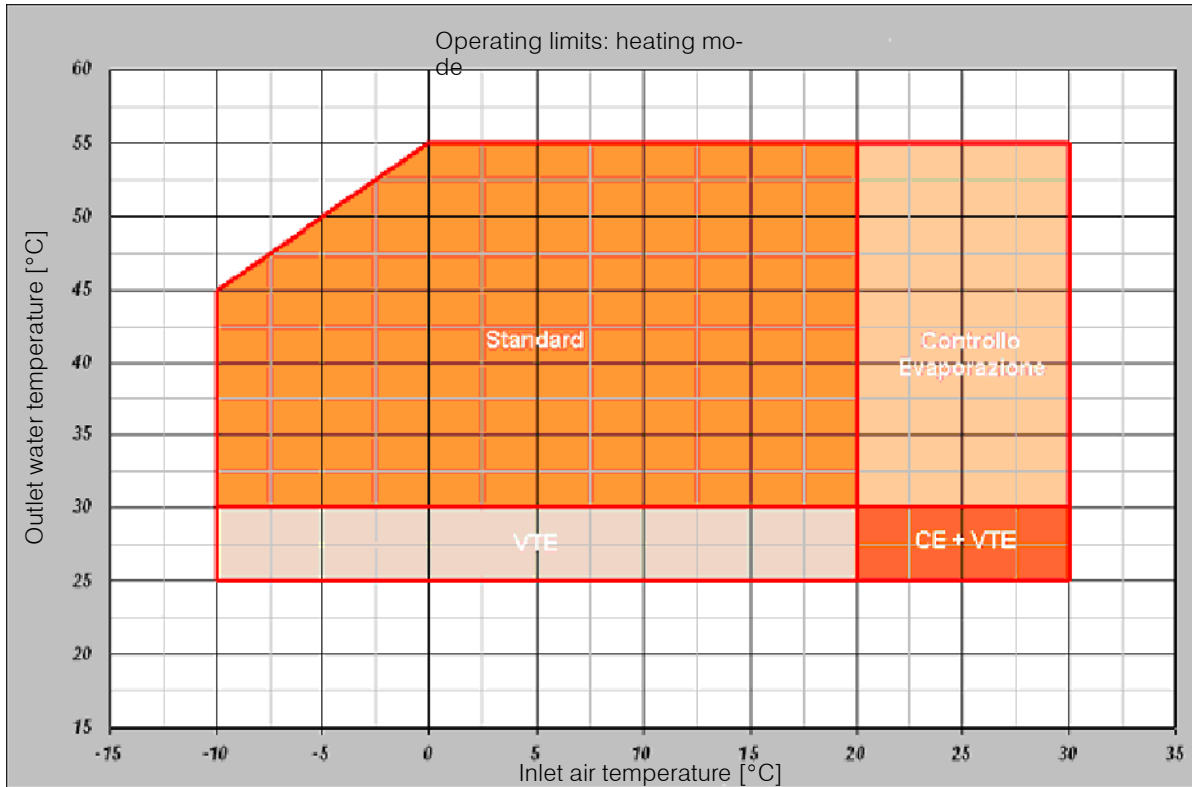

## Thermal carrier fluid

The units belonging to the LCE series can work with mixtures of water and up to 35% ethylene glycol.

## Pressure Drops

The diagram shows the evaporator pressure drops ( $D_p$ ) as a function of the water flow rate ( $Q_w$ ), assuming an average water temperature of 10°C.

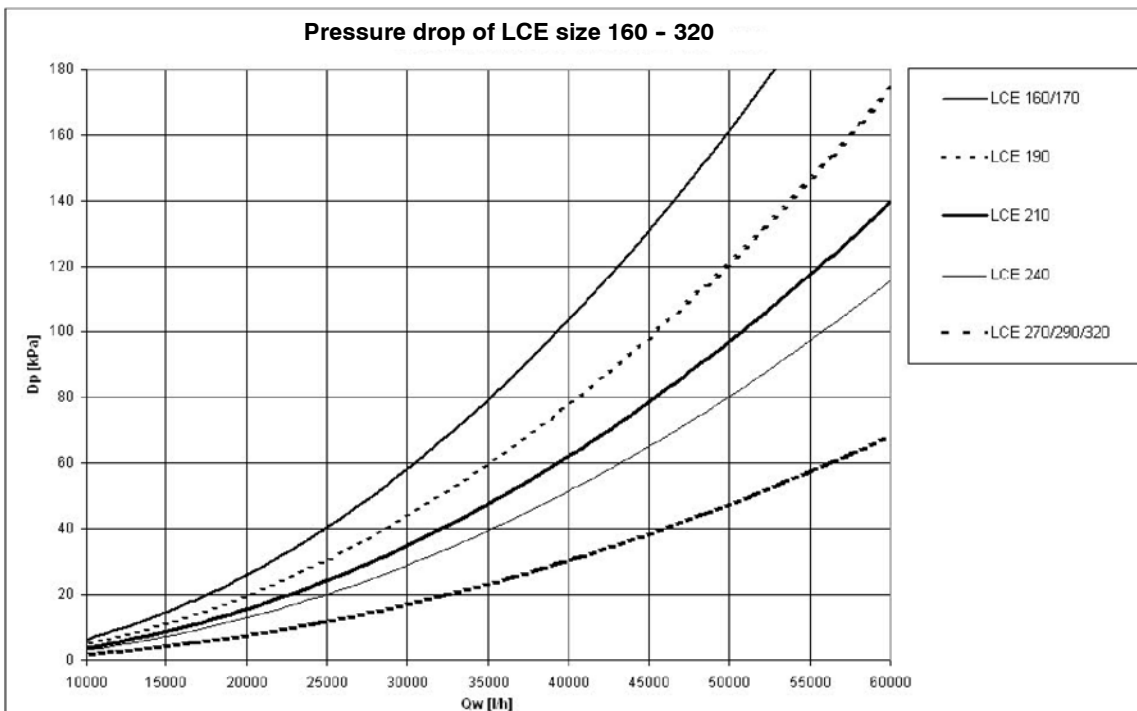
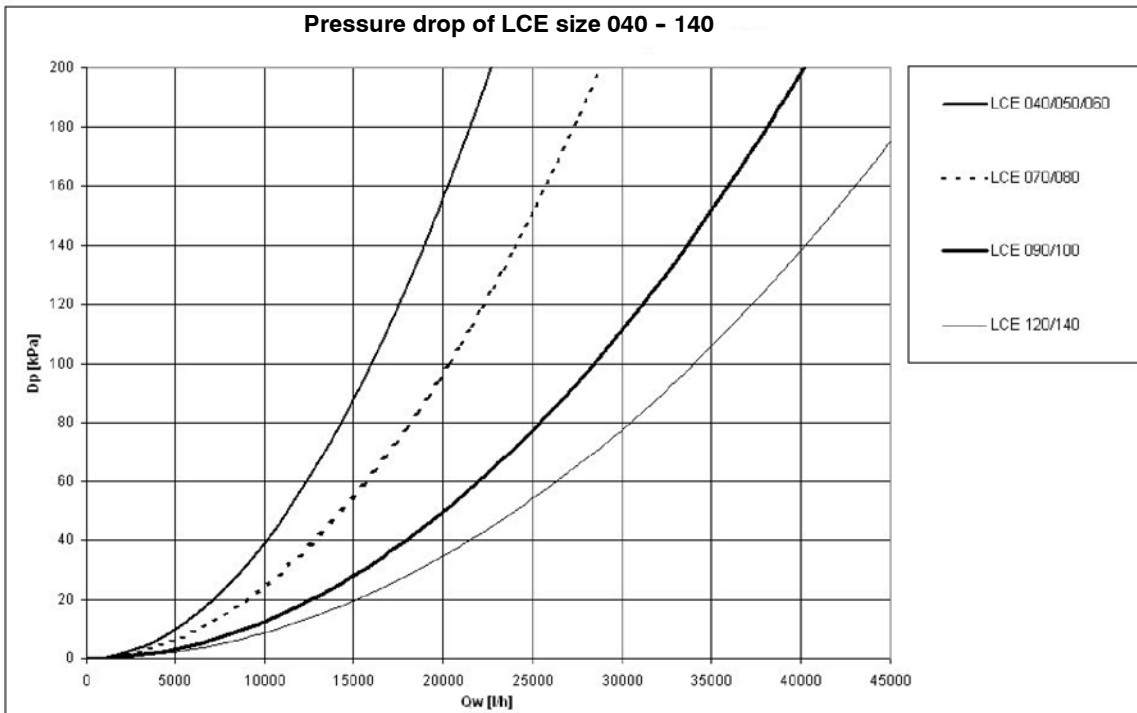



# Pressure Drops



The diagram shows the evaporator pressure drops ( $D_p$ ) as a function of the water flow rate ( $Q_w$ ), assuming an average water temperature of 10°C.

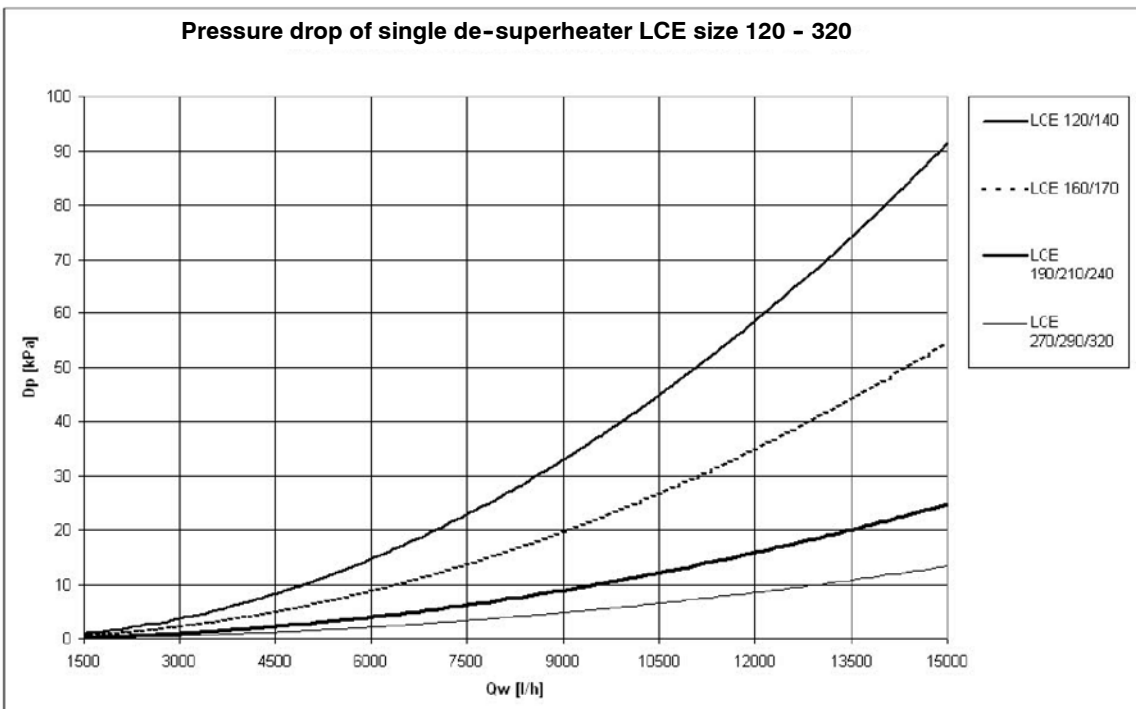
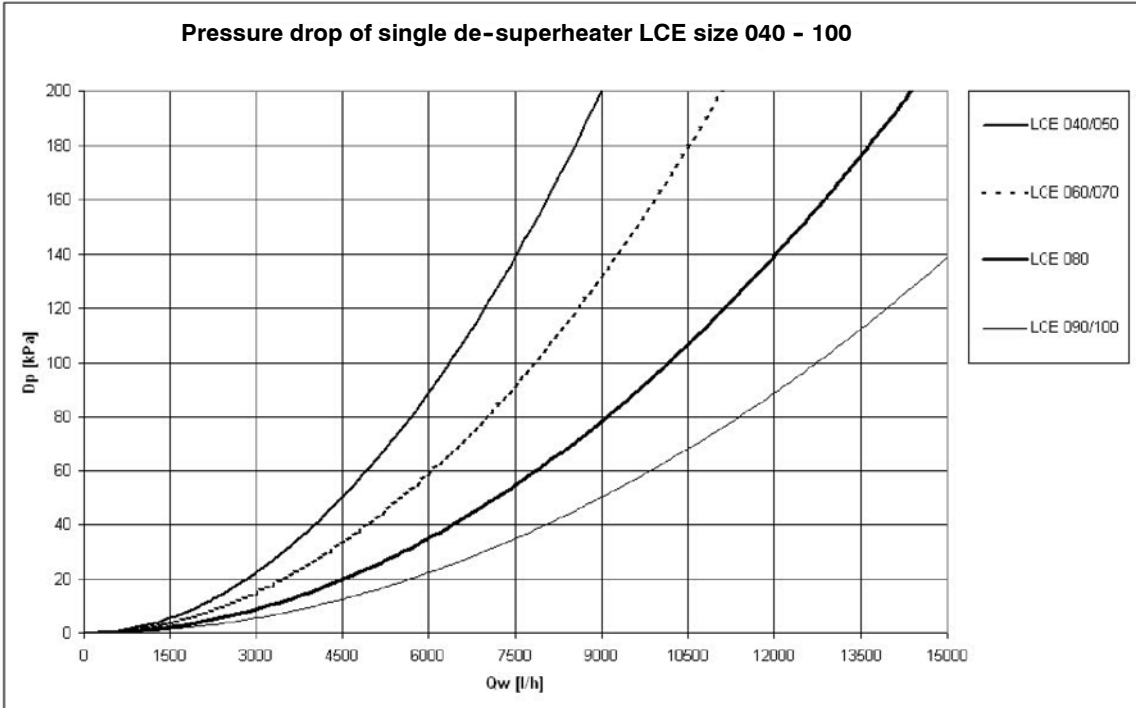

# Pressure Drops



The diagram shows the evaporator pressure drops ( $D_p$ ) as a function of the water flow rate ( $Q_w$ ), assuming an average water temperature of 10°C.

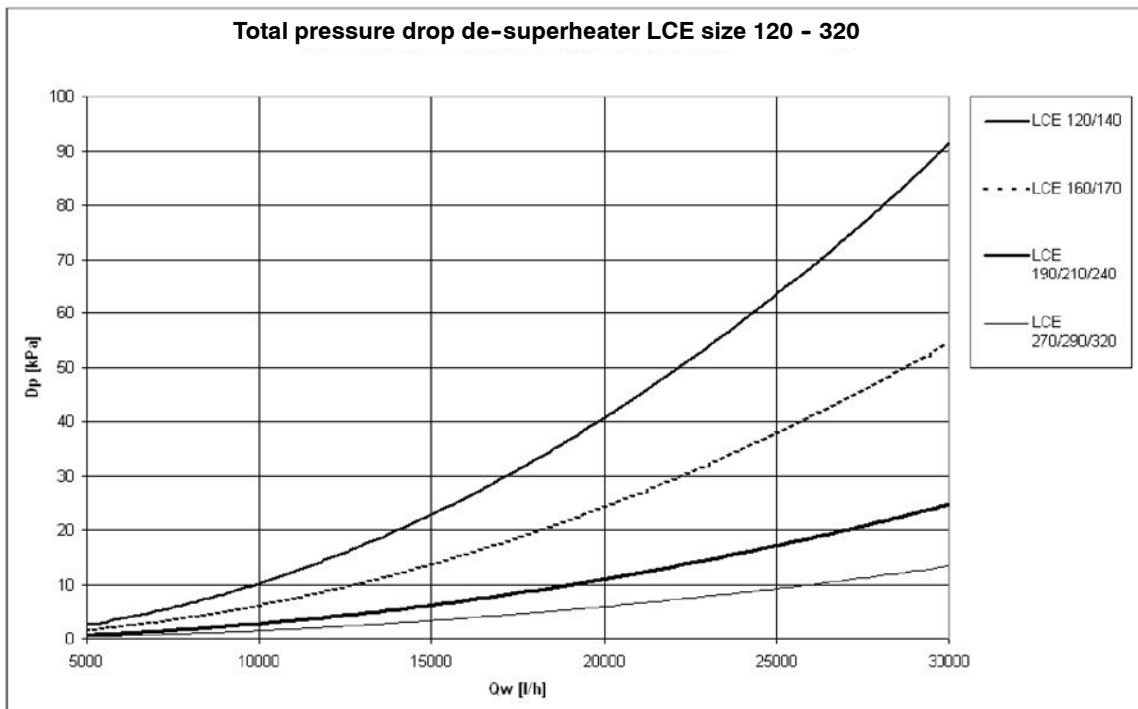
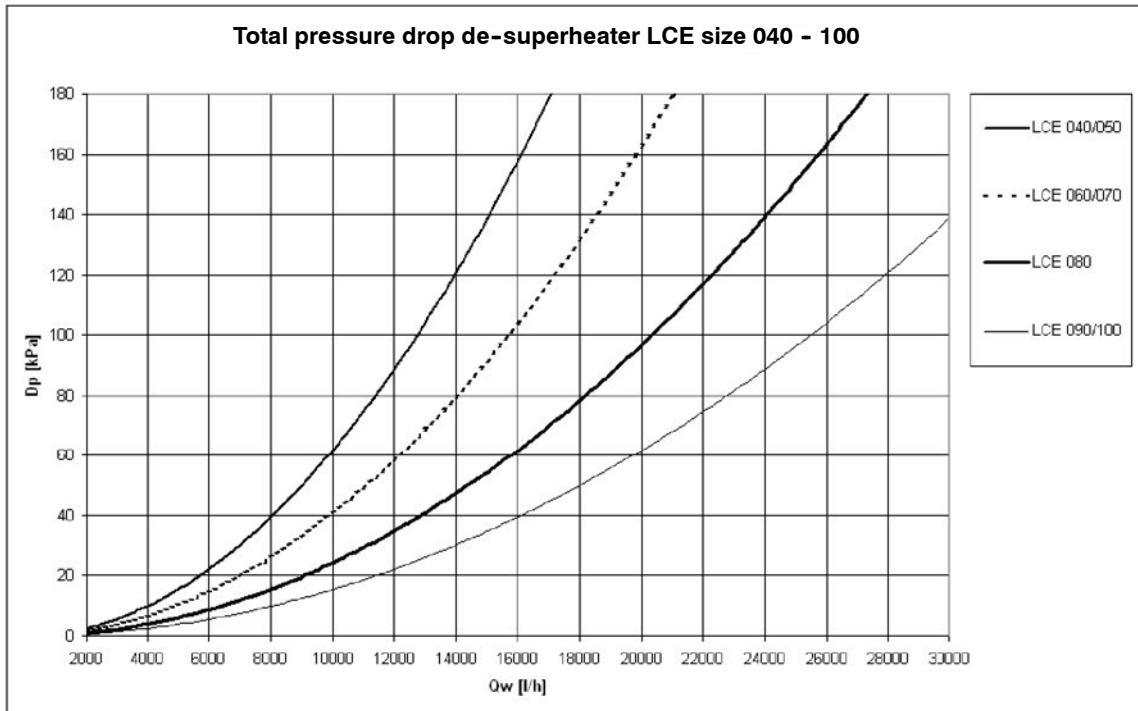

## Pumping Systems

Standard single or dual pump with alternating operation ("OR")

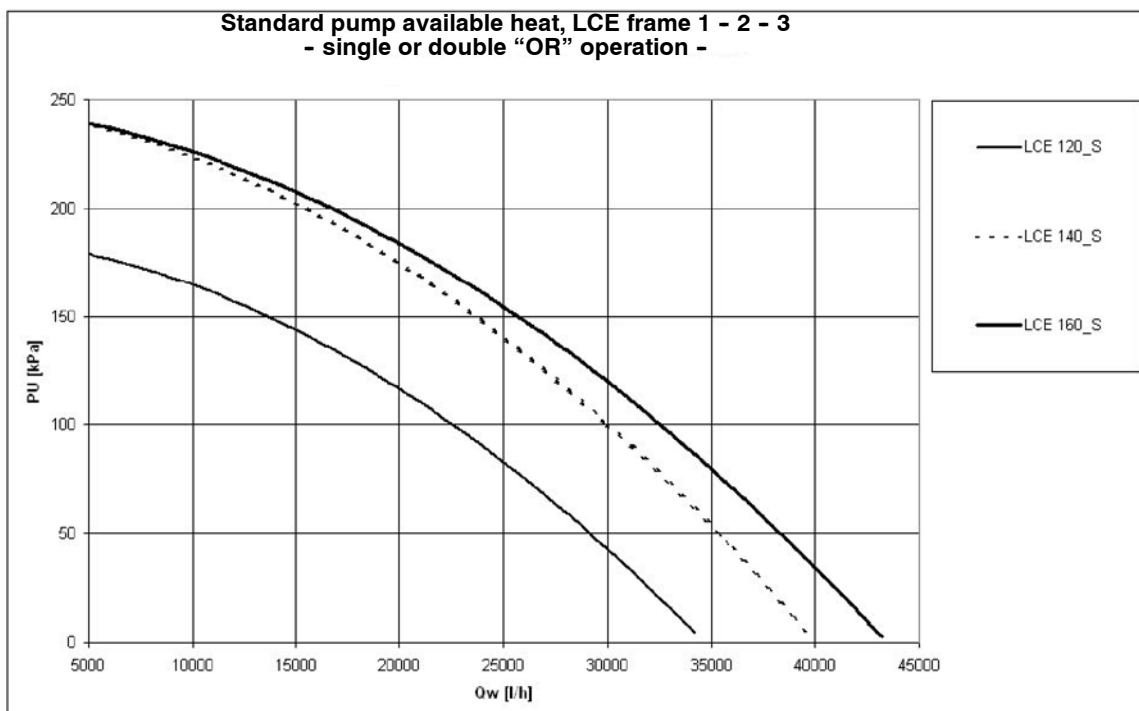
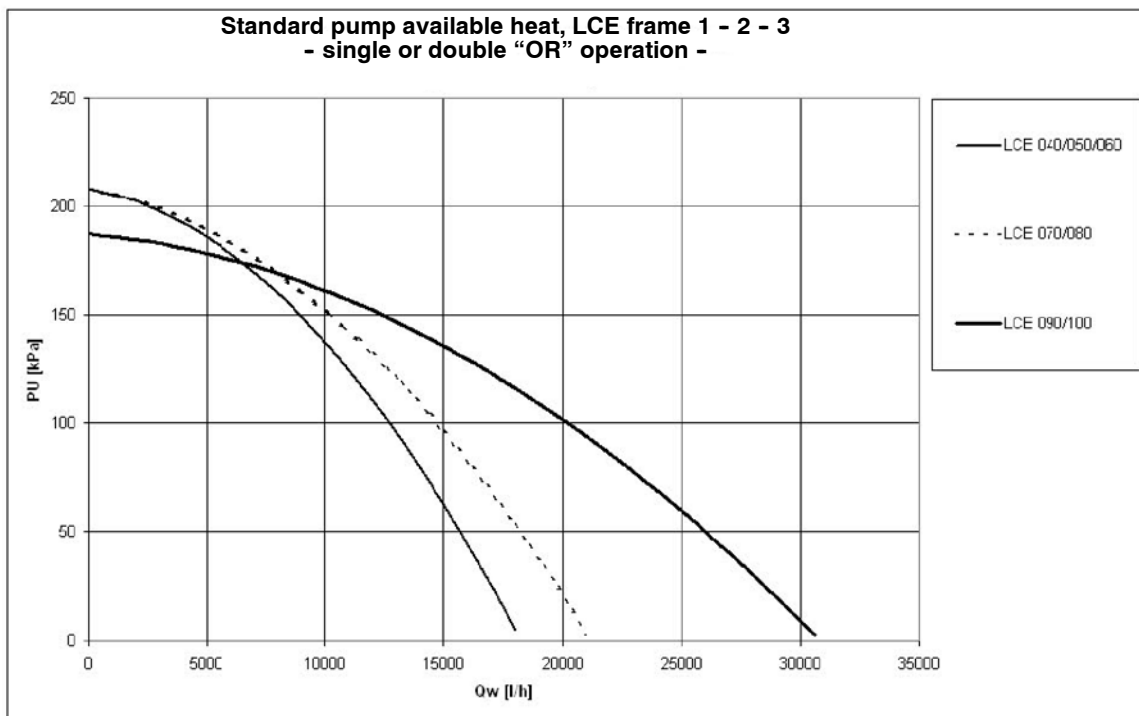

## Standard single or dual pump with alternating operation ("OR")

Standard pump available heat, LCE frame 4  
- single or double "OR" operation -

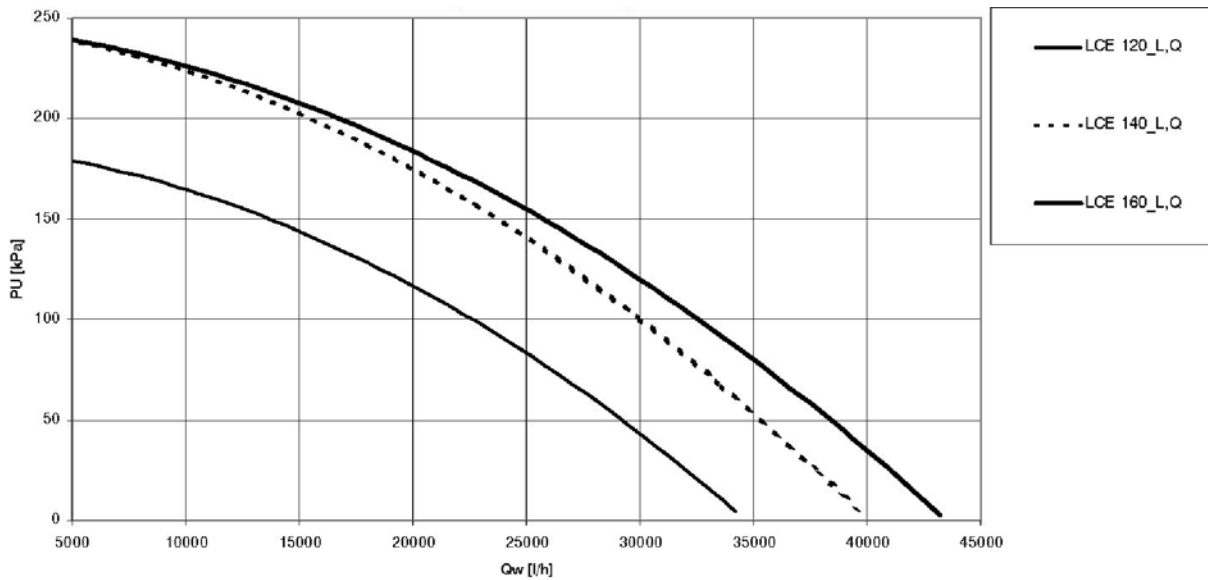

Standard pump available heat, LCE frame 1 - 2 - 3  
- single or double "OR" operation -

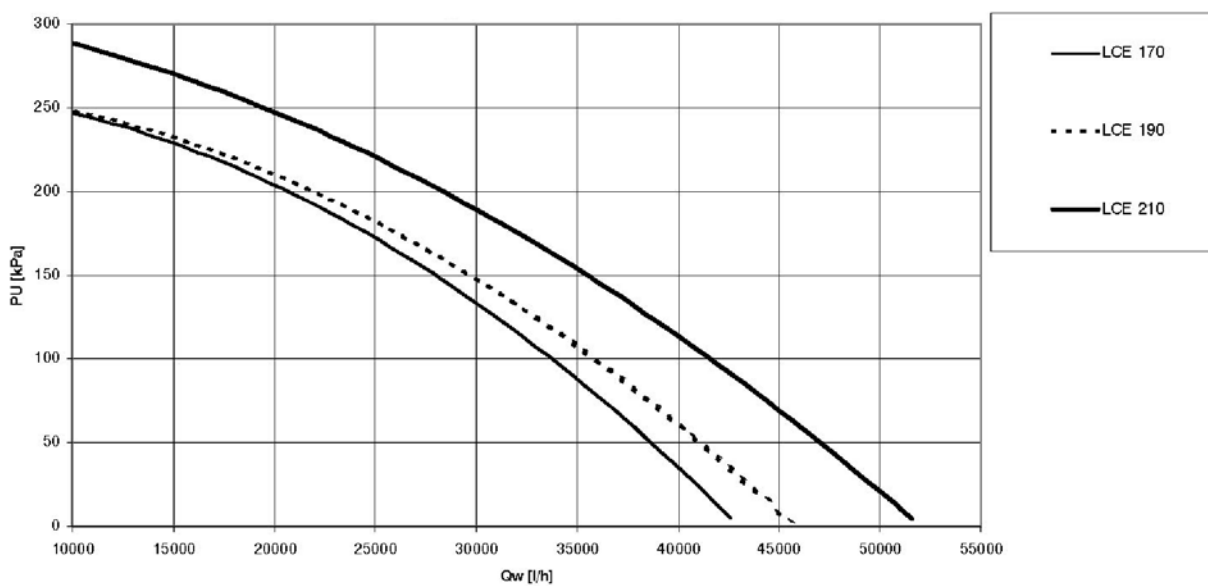

## Standard single or dual pump with alternating operation ("OR")

Standard pump available heat, LCE frame 5 - 6  
- single or double "OR" operation -

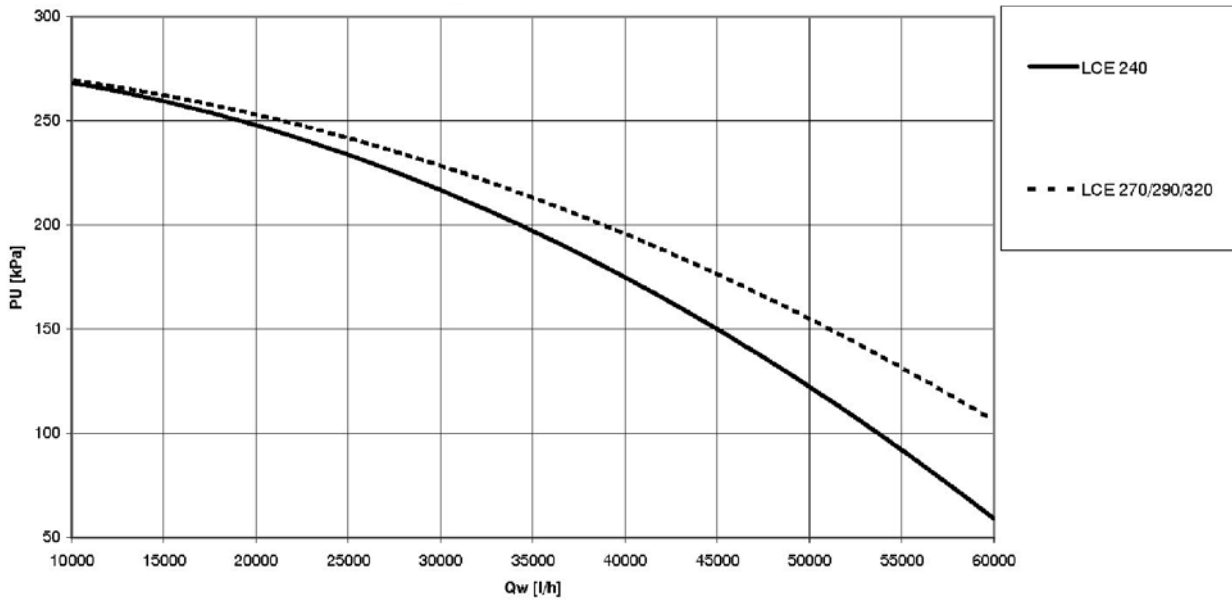

## Upated single or dual pump wirh alternating operation (“OR”)

Upated pump available heat, LCE frame 1 - 2 - 3  
- single or double “OR” operation -

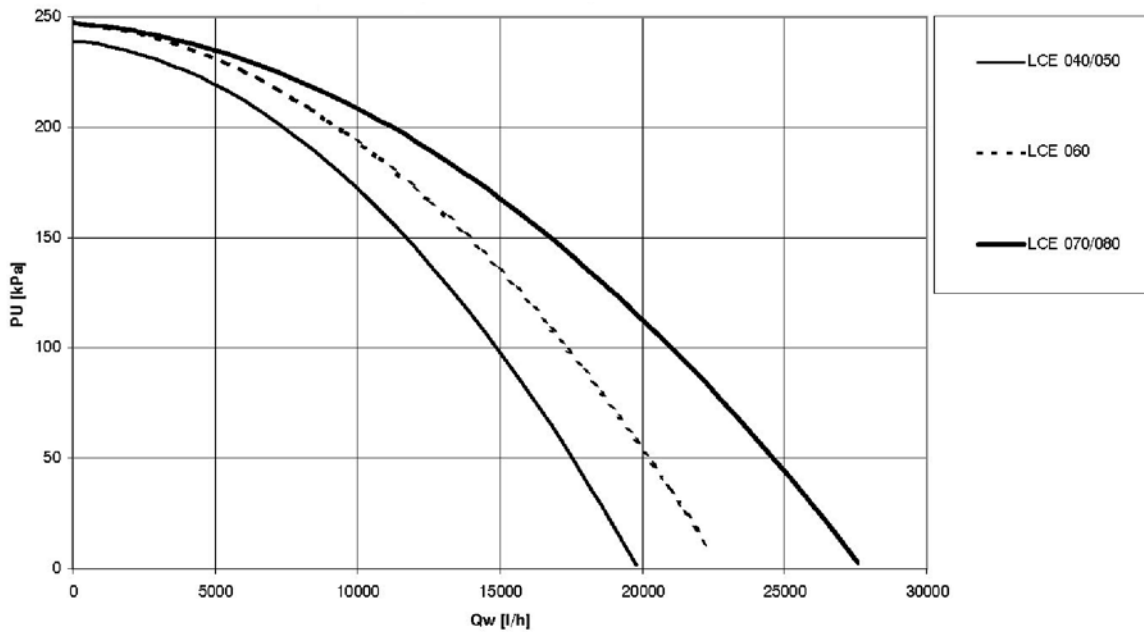

Upated pump available heat, LCE frame 1 - 2 - 3  
- single or double “OR” operation -

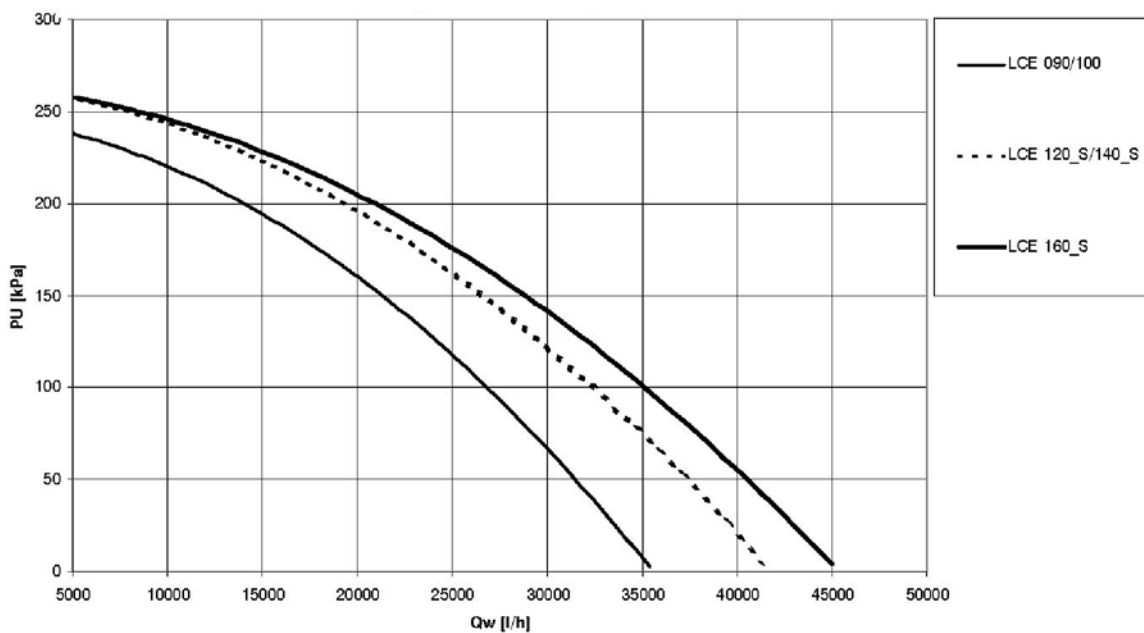

## Upated single or dual pump wirh alternating operation (“OR”)

Upated pump available heat, LCE frame 4  
- single or double “OR” operation -

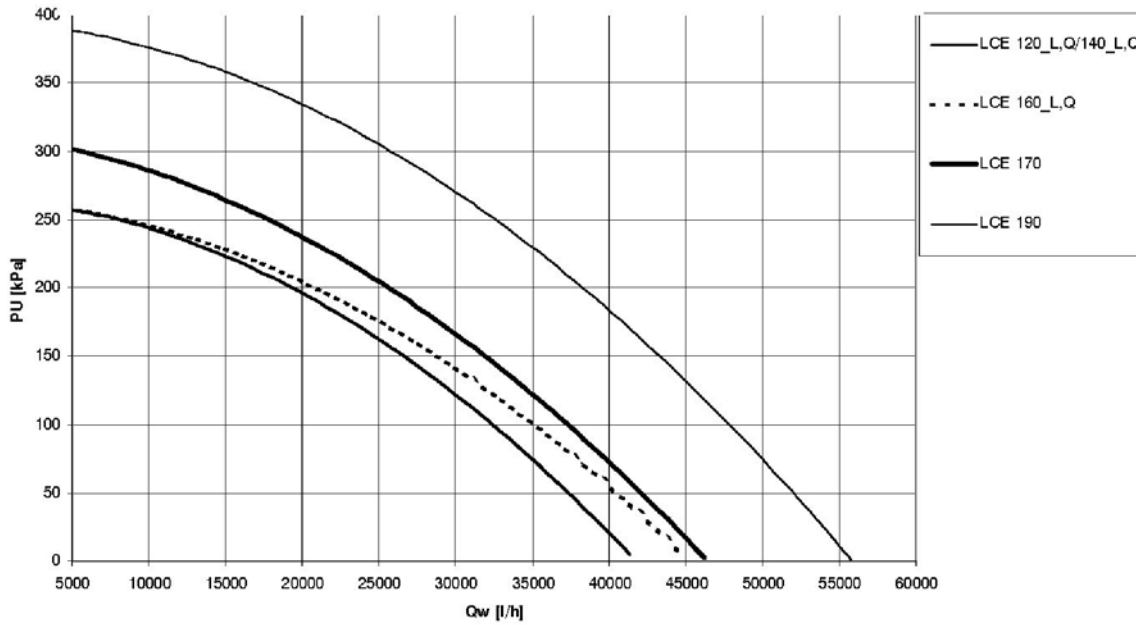

Upated pump available heat, LCE frame 4 - 5 - 6  
- single or double “OR” operation -

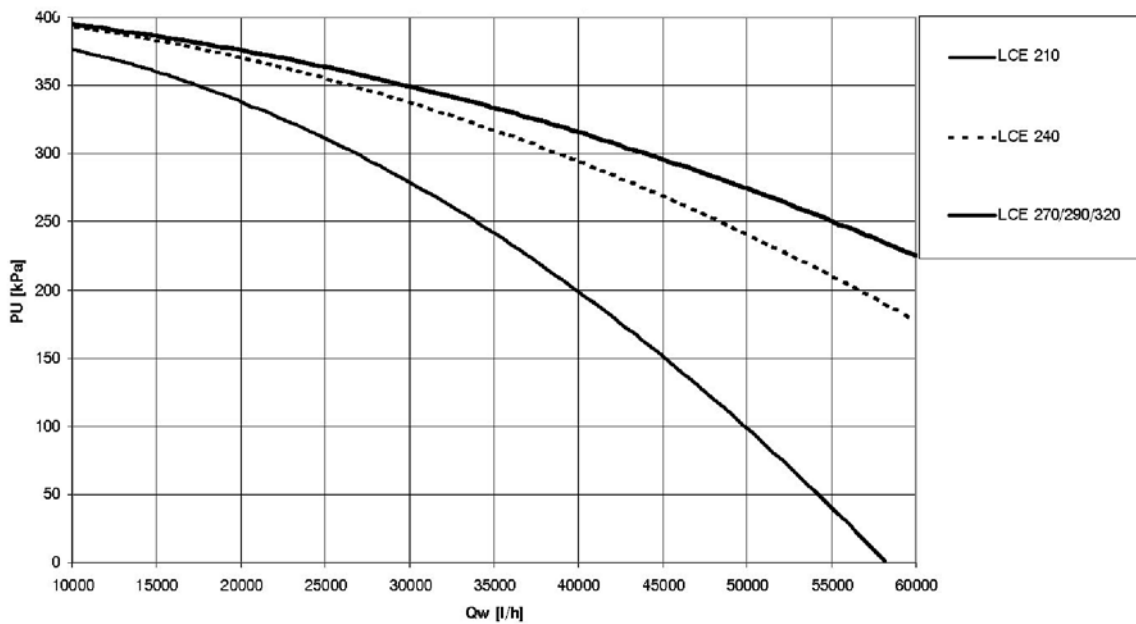

## Standard dual pump with simultaneous operation ("AND")

Standard pump available heat, LCE frame 1 - 2 - 3  
- double "AND" operation -

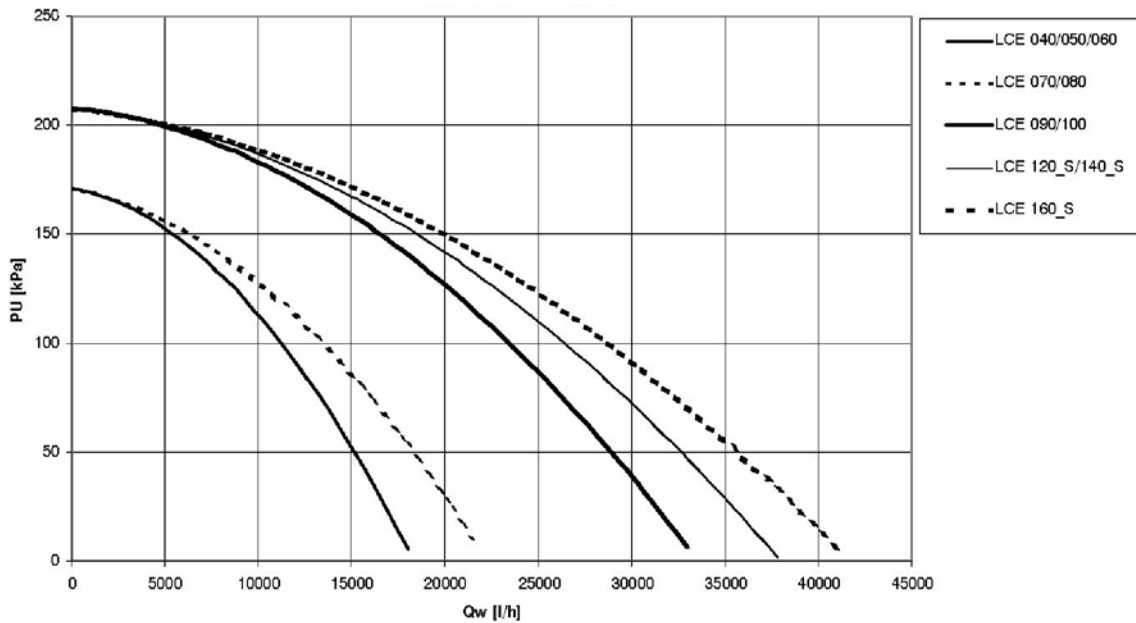

Standard pump available heat, LCE frame 4  
- double "AND" operation -

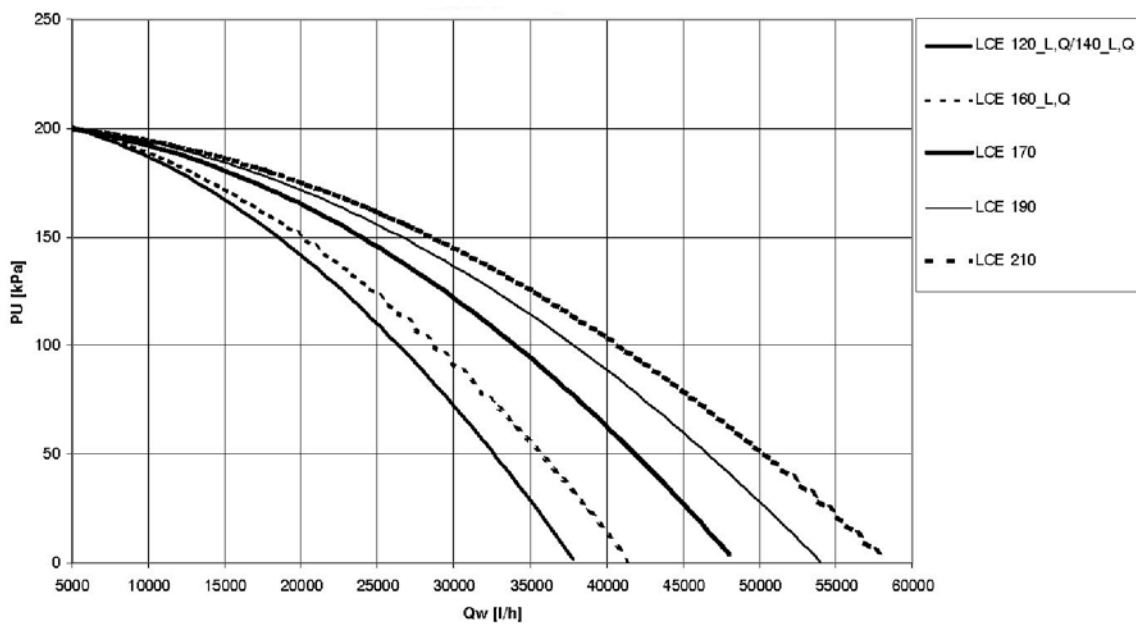



## Standard dual pump with simultaneous operation ("AND")

Standard pump available heat, LCE frame 4  
- double "AND" operation -

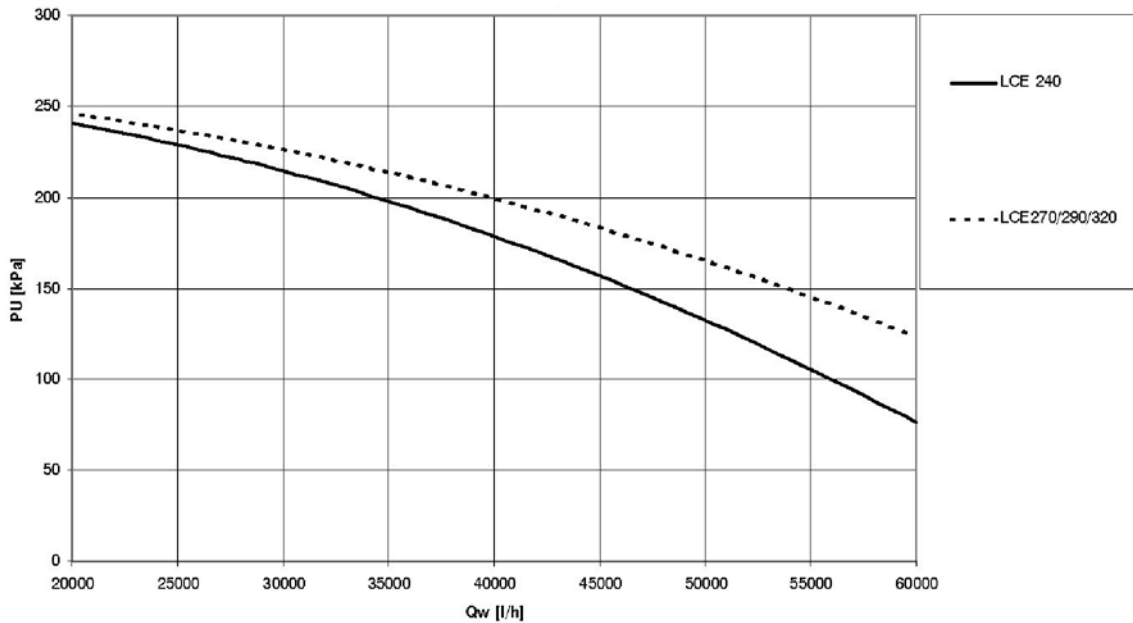

Upated pump available heat, LCE frame 1 - 2 - 3  
- double "AND" operation -

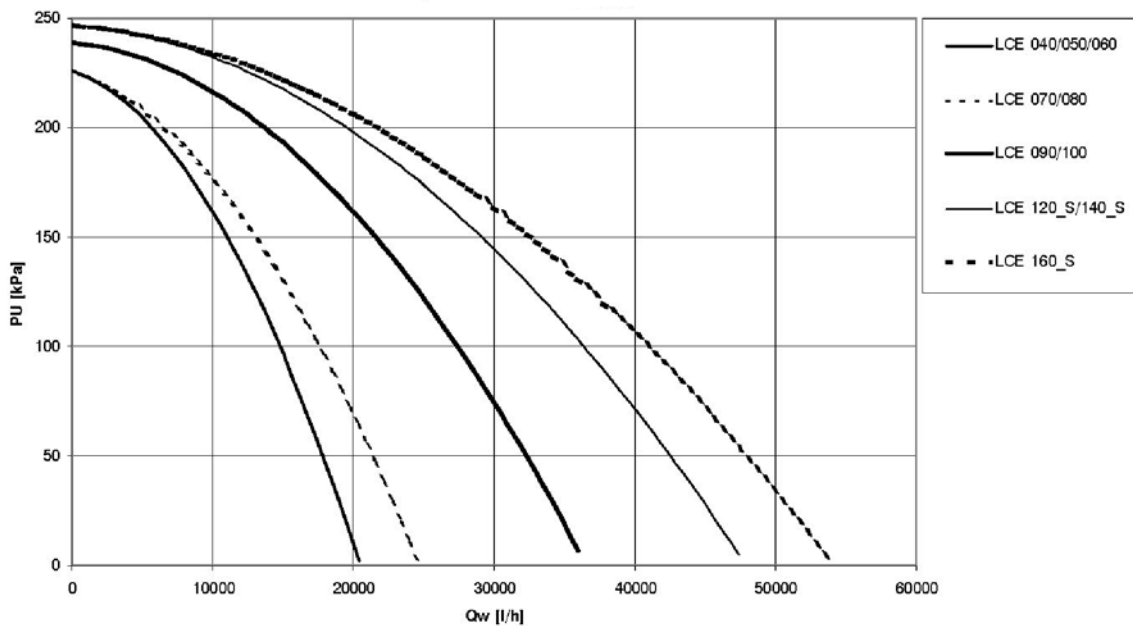

## Upated dual pump wirh simultaneous operation (“AND”)

Upated pump available heat, LCE frame 4  
- double “AND” operation -

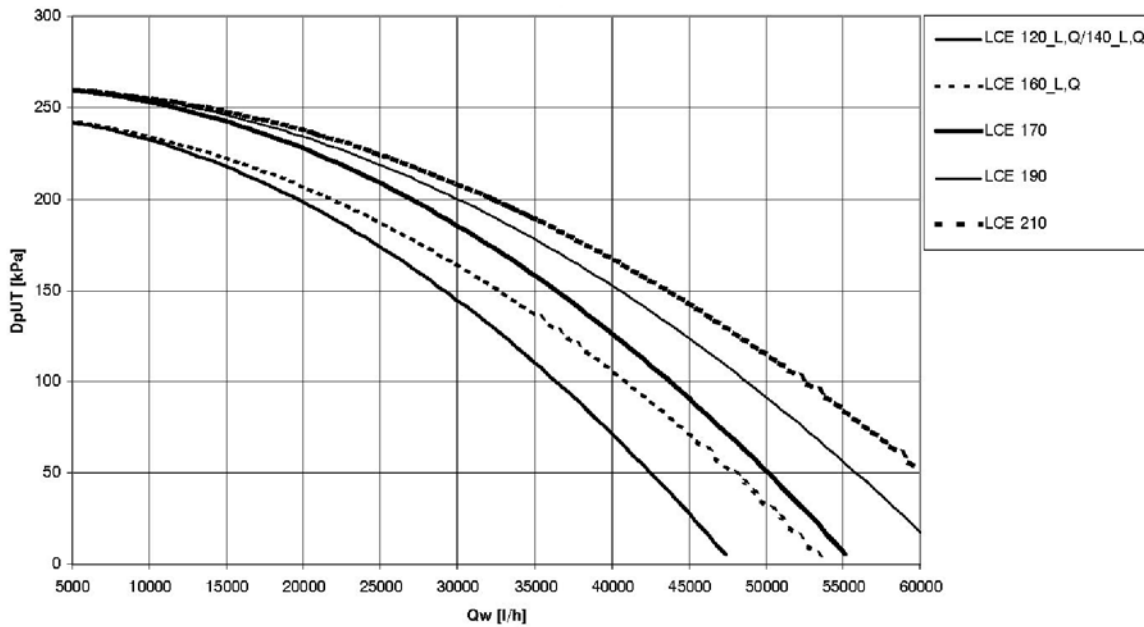

Upated pump available heat, LCE frame 5 - 6  
- double “AND” operation -

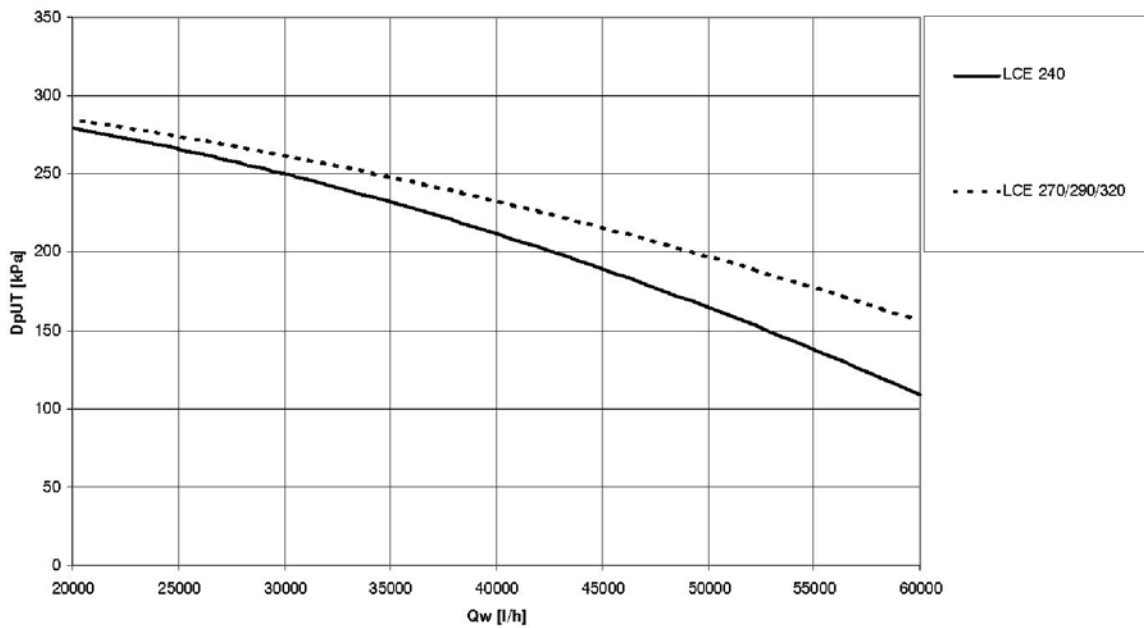

## Water Circuit

When setting up the water circuit of the unit, it is advisable to follow the directions below and in any case comply with local or national regulations.

Connect the pipes to the chiller using flexible couplings to prevent the transmission of vibrations and to compensate thermal expansions.

It is recommended to install the following components on the pipes:

- pair of quick connect couplings with welding ring (optional selectable from the price list). They facilitate the operations of connecting the unit to the system and greatly speed up installation.
- Temperature and pressure indicators for routine maintenance and monitoring of the unit. Checking the pressure on the water side will enable you to verify whether the expansion tank is working efficiently and to promptly detect any water leaks within the equipment.
- Traps on incoming and outgoing pipes for temperature measurements, which can provide a direct reading of the operating temperatures. Temperature readings can in any case be obtained from the microprocessor installed on the unit.

- Regulating valves (gate valves) for isolating the unit from the water circuit.
- Metal mesh filter, with a mesh size no greater than 1 mm, to be fitted on the inlet pipe to protect the exchanger from scale or impurities present in the pipes.
- Air vent valves, to be placed at the highest points of the water circuit for the purpose of bleeding air. (The internal pipes of the unit are fitted with small air vent valves for bleeding the unit itself: this operation may only be carried out when the unit is disconnected from the power supply). Make sure that the circuit is completely full of water. Then carefully bleed out the air and check again that no air is present before starting the pump for the first time.
- Drainage valve and, where necessary, a drainage tank for emptying out the equipment for maintenance purposes or when the unit is taken out of service at the end of the season. (A 1" drainage valve is provided on the optional water buffer tank: this operation may only be carried out when the unit is disconnected from the power supply).

It is of fundamental importance that the incoming water supply is hooked up to the connection marked "Water Inlet".

Otherwise the evaporator would be exposed to the risk of freezing since the antifreeze thermostat would not be able to perform its function; moreover the reverse cycle would not be respected in the cooling mode, resulting in additional risks of malfunctioning.

The dimensions and position of plumbing connections are shown in the dimension tables at the end of this manual.

The water circuit must be set up in such a way as to guarantee that the nominal flow rate of the water supplied to the evaporator remains constant (+/- 15%) in all operating conditions.

A standard feature of the units is a device for controlling the flow rate (flow switch) in the water circuit in the immediate vicinity of the evaporator.

### Legend

- 1 Water inlet
- 2 Water outlet
- 3 Circulation pump
- 4 Gate valve
- 5 Safety valve
- 6 Expansion tank
- 7 Inertial buffer tank
- 8 Check valve

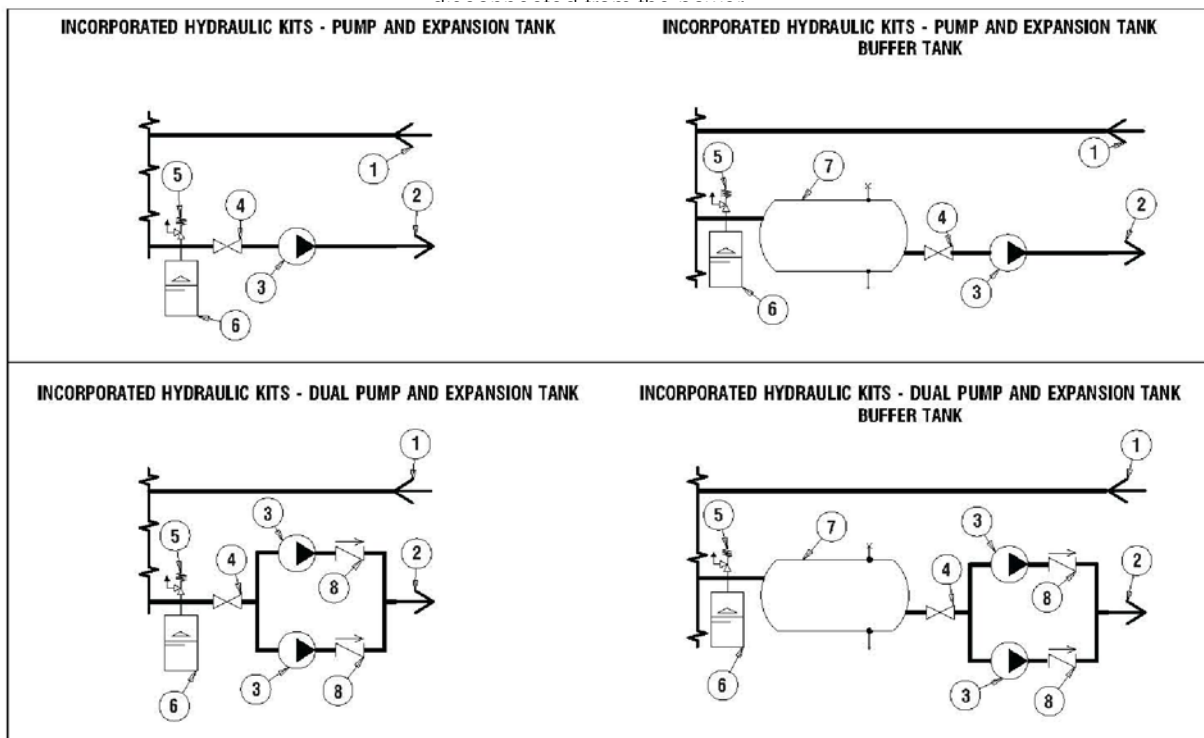

## Electrical Connections

The electrical connections must be made in accordance with the information shown in the wiring diagram provided with the unit and current regulations.

A standard feature of all units is a phase sequence relay which verifies that the phase sequence is correct: this is necessary to ensure the complete functionality of the machine before enabling compressor start-up.

If you wish to include a remote control for switching the unit on and off, you must remove the bridge between the contacts indicated in the wiring diagram and connect the remote ON/OFF control to the terminals themselves.

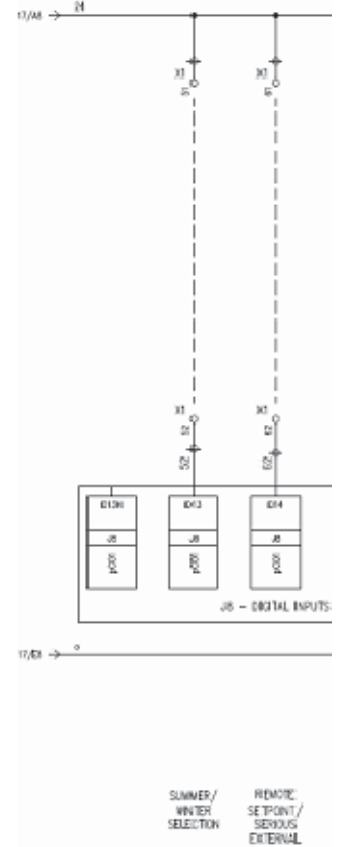
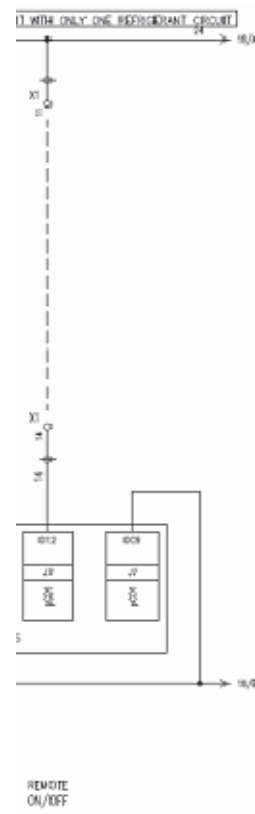
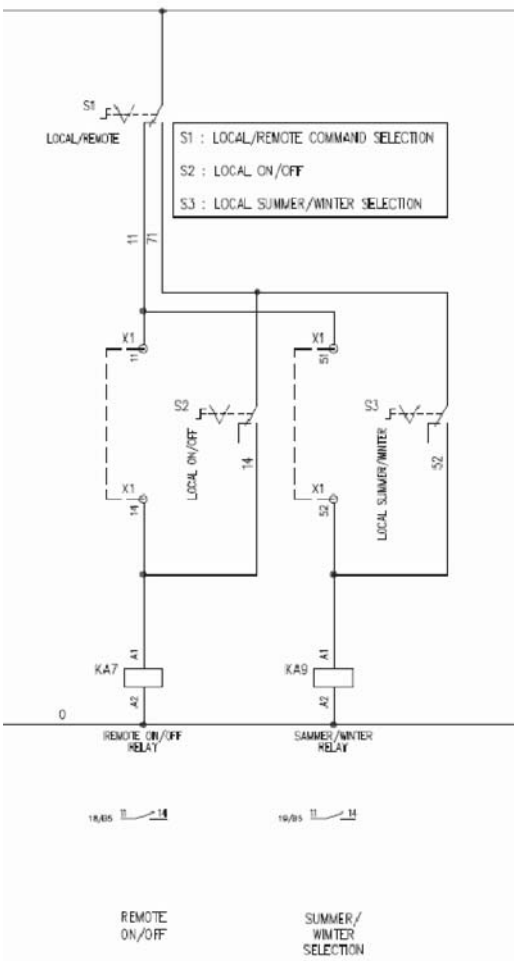

# Overall Dimensions



## Overall Dimensions

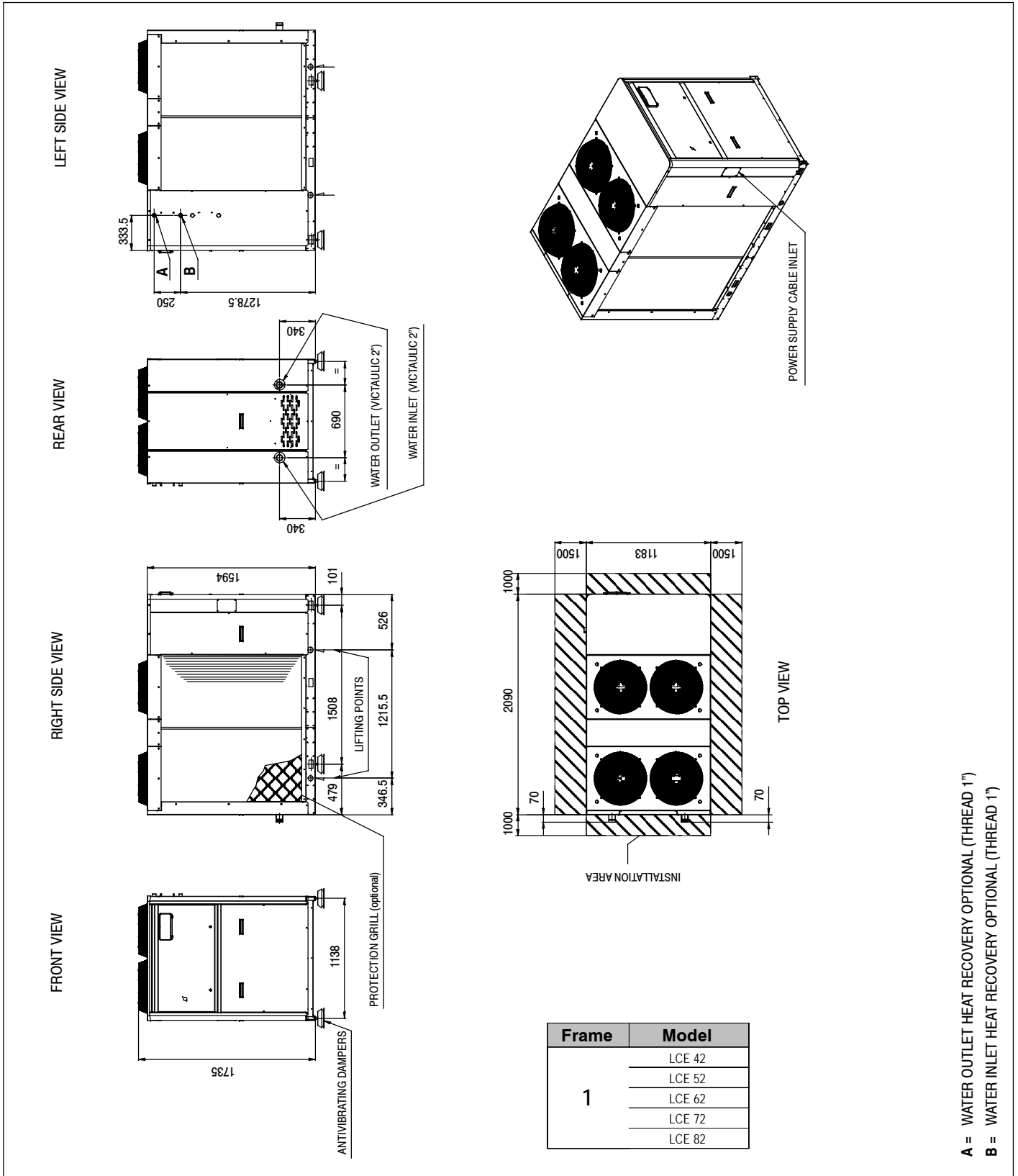

# Overall Dimensions

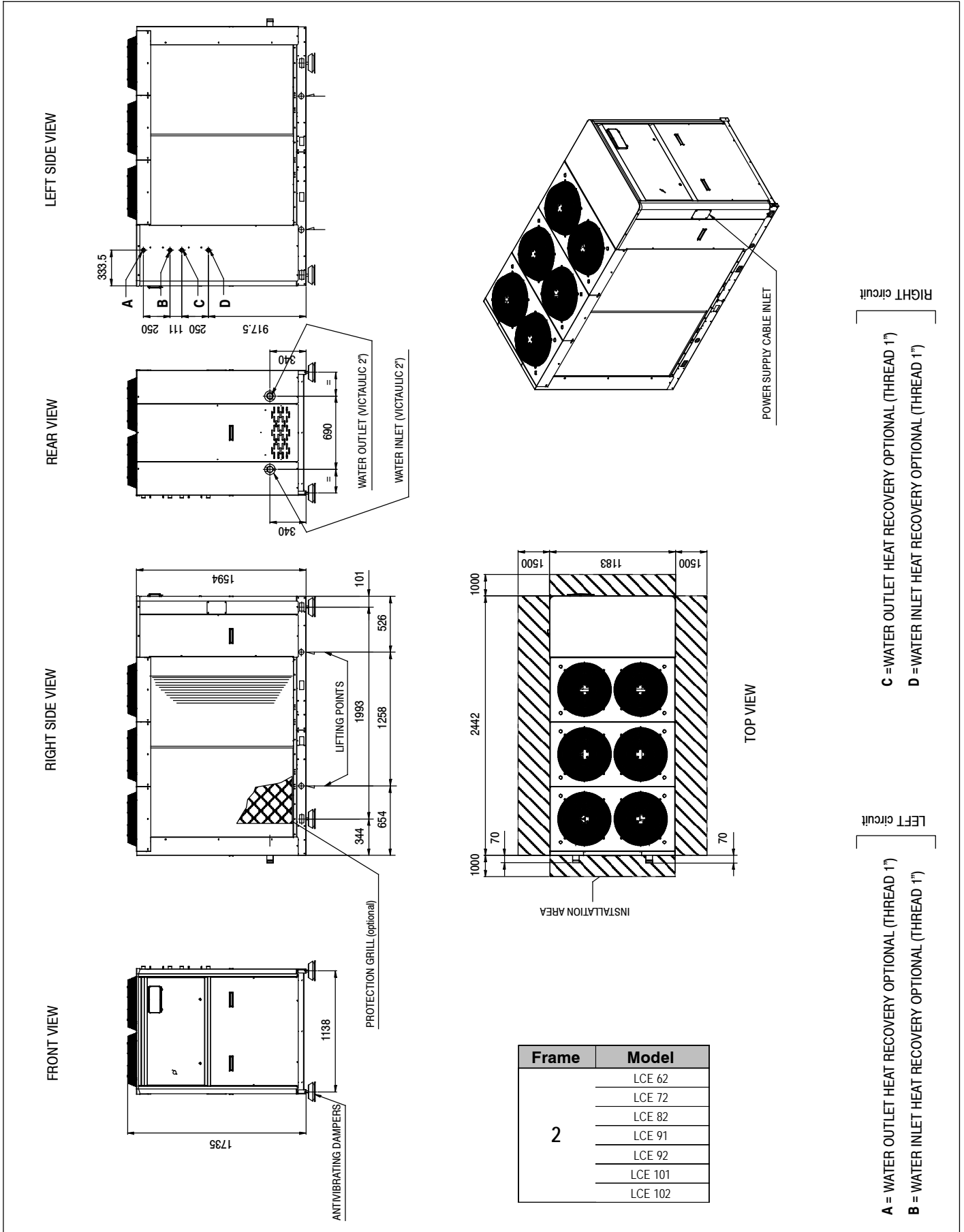

# Overall Dimensions

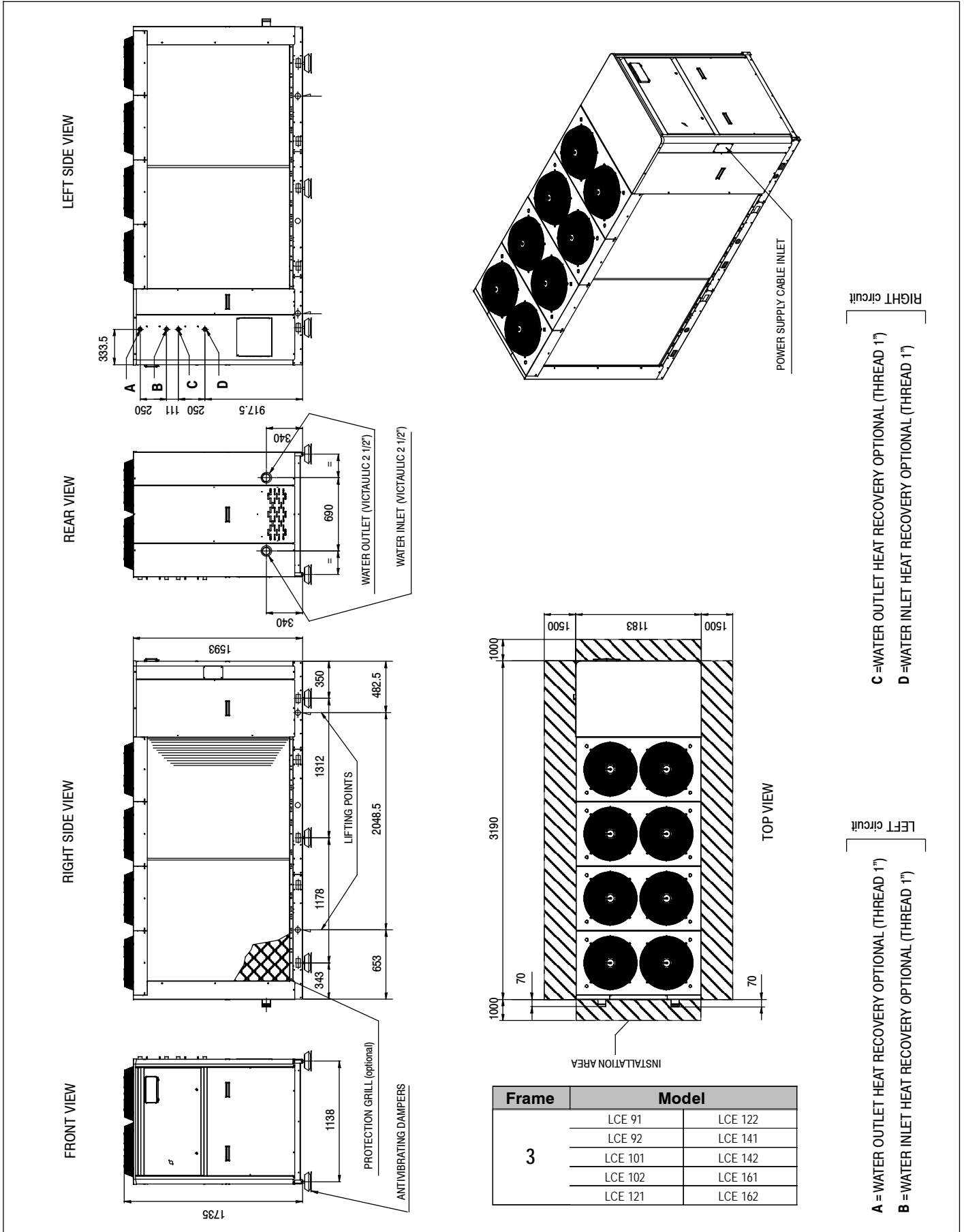

# Overall Dimensions

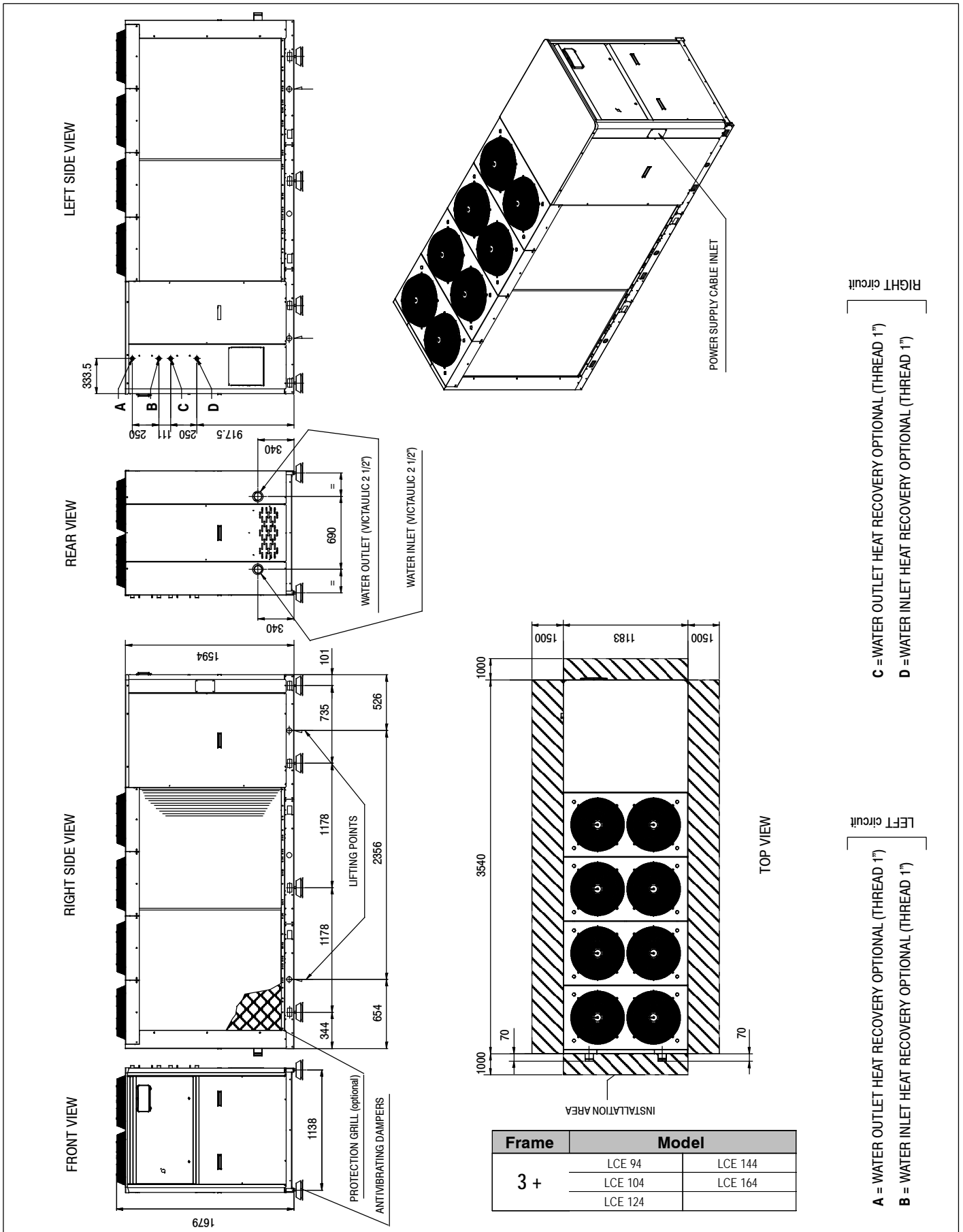



# Overall Dimensions

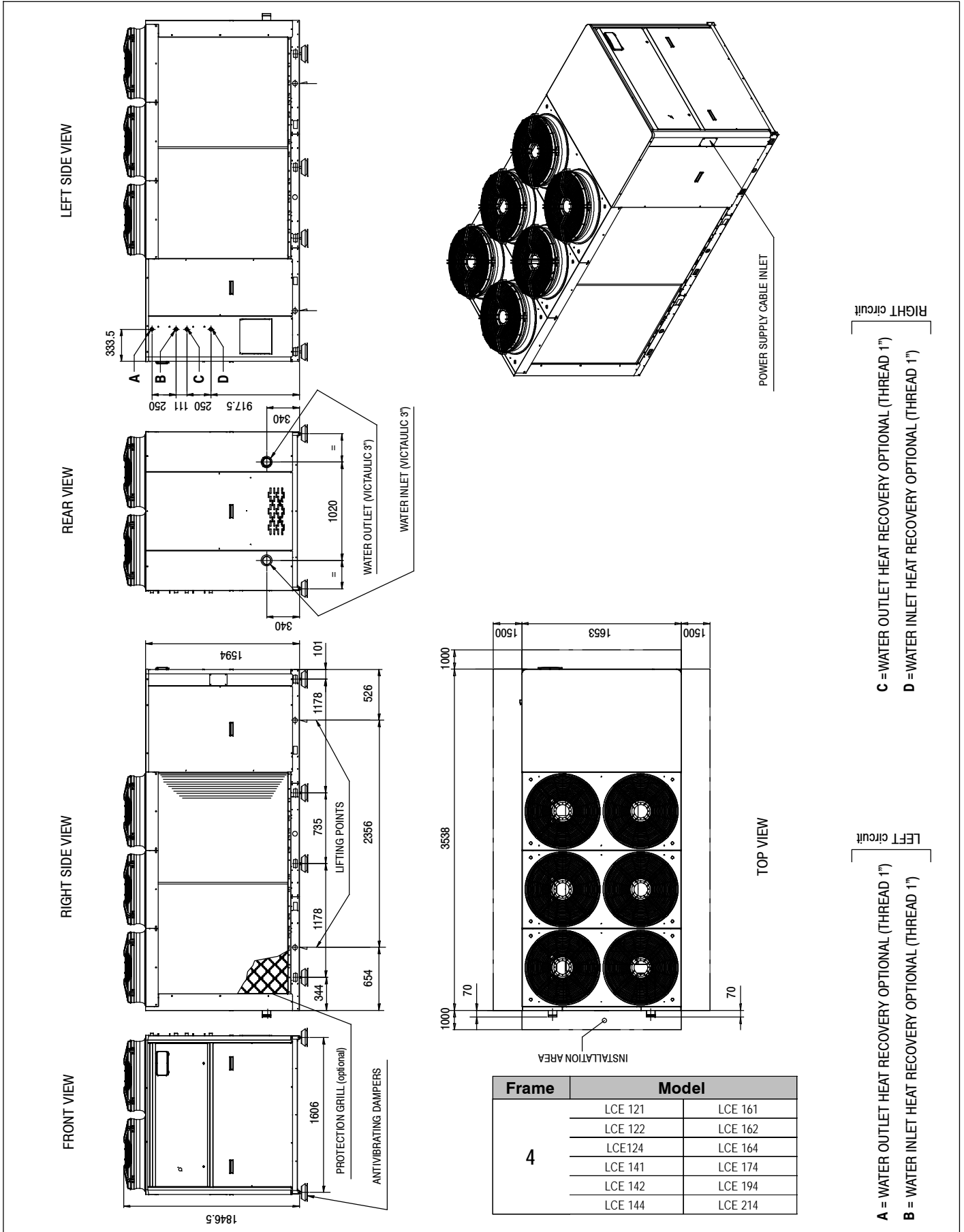

# Overall Dimensions

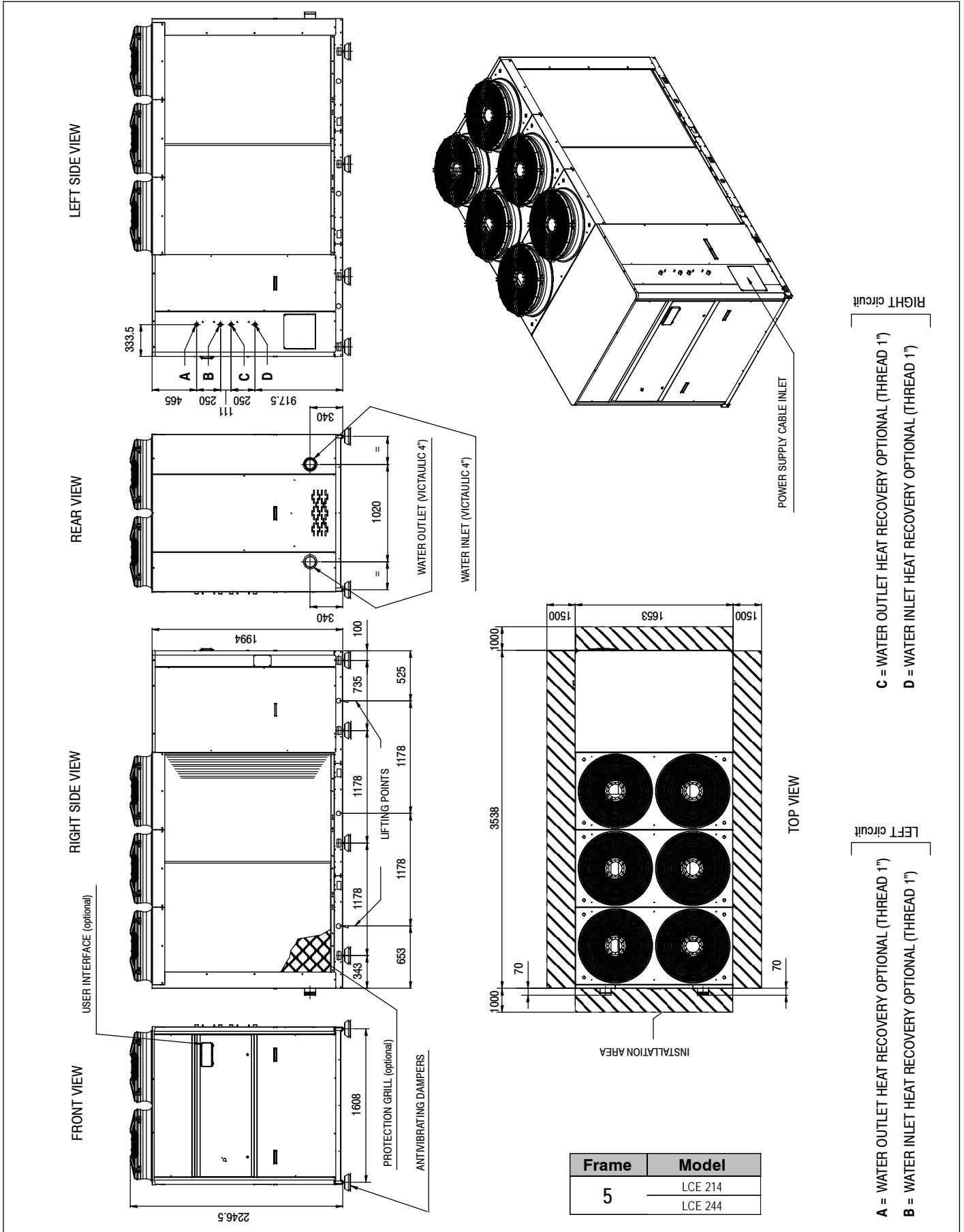

# Overall Dimensions

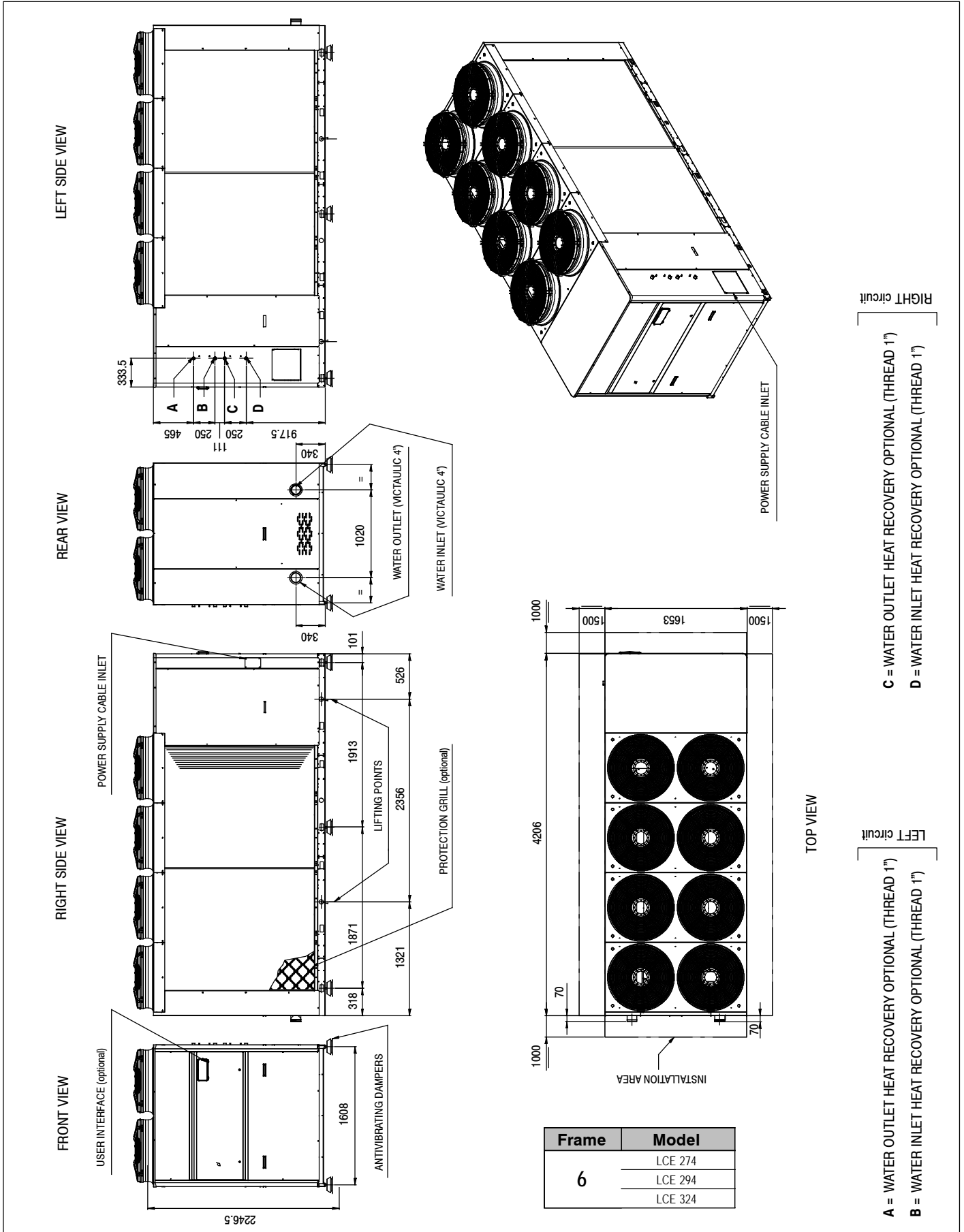

## Installation Clearance Requirements

You should bear in mind the following aspects when choosing the best site for installing the unit and the relative connections:

- size and origin of water pipes;
- location of power supply;
- accessibility for maintenance or repairs;
- solidity of the supporting surface;
- ventilation of the air-cooled condenser and necessary clearance;
- direction of prevalent winds: avoid positioning the unit in such a way that the prevalent winds favour the backflow of air to the condenser coils; a speed of 8 m/s (28.8 km/h) already generates a sufficient stagnation pressure to guarantee 60% of the nominal air flow rate. (In situations where the action of the wind is inevitable and there is a simultaneous presence of temperatures below -5°C, the control of condensation for low outdoor temperatures must be of the flooding type or with capacity control routine of the condensing exchanger -contact the technical department for further details).
- possible reverberation of sound waves.

All models belonging to the LCE series are designed and built for outdoor installation: avoid covering them with roof structures or positioning them near plants (even if they only partly cover the unit) which may interfere with the regular ventilation of the unit condenser.

It is a good idea to provide a supporting base of adequate dimensions. This precaution becomes an imperative when the unit is to be sited on unstable ground (various types of soil, gardens, etc.).

It is advisable to place a rigid rubber strip between the base frame and the supporting surface.

Whenever more effective insulation is required, it is recommended to use vibrating-damping spring supports.

In the case of installation on roofs or intermediate storeys, the unit and pipes must be insulated from walls and ceilings by placing rigid rubber joints in between and using supports that are not rigidly anchored to the walls.

If the unit is to be installed in proximity to private offices, bedrooms or areas where noise levels must be kept down, it is advisable to conduct a thorough analysis of the sound field generated and verify its compatibility with the local laws in force.

It is of fundamental importance to ensure an adequate volume of air both on the intake and outlet sides of the condenser/evaporating finned coils; it is highly important to prevent the air delivered from being re-aspirated as this may impair the performance of the unit or even cause an interruption in normal operation.

For this reason it is necessary to guarantee the following clearances (see figure on this page):

- rear side/plumbing connections: min. 1,0 metres to guarantee access to plumbing connections and/or for any necessary maintenance on the pumps, tank, expansion tank and flow switch.
- electric control board side: min. 1.0 metres to guarantee access for inspection and/or maintenance of cooling components.
- finned block exchanger side: min. 1.5 metres to ensure proper air circulation and access to the compressor compartment, also from the side.
- top side: there must be no obstacle to air outlet.

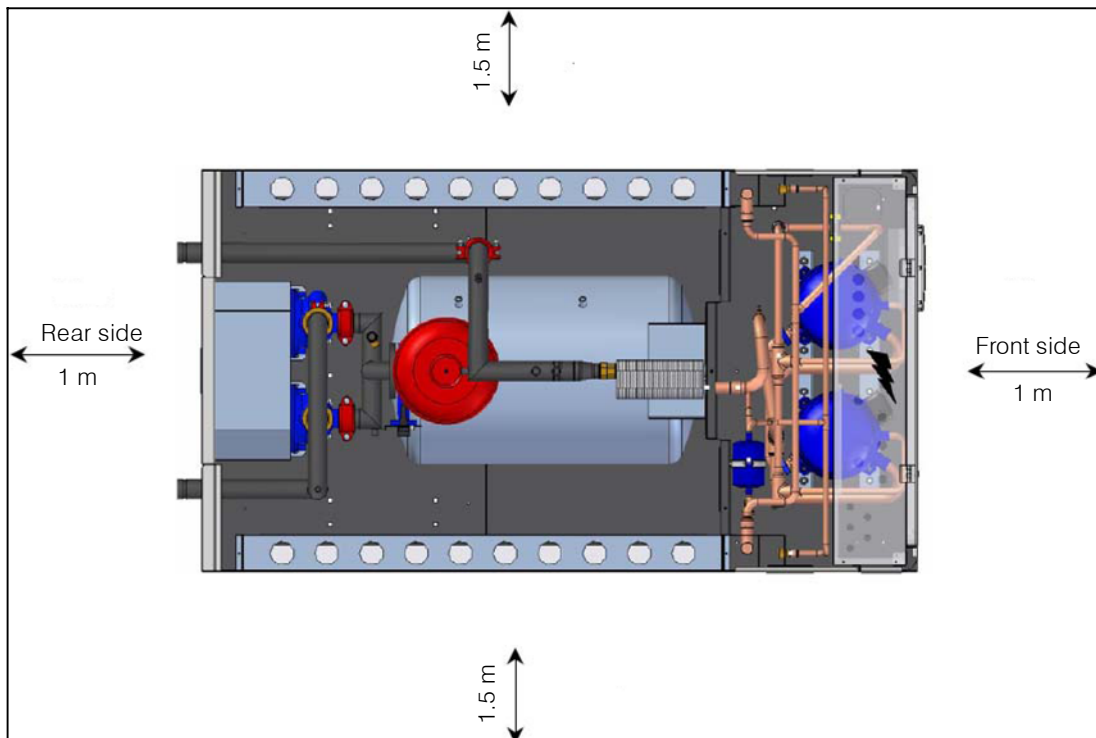

## Unit Weights

This drawing shows the points of the machine for which weights have been calculated, with respect to the basic chiller and heat pump model. The weights are shown in the tables below.

**Important note: the weights of the hydronic modules must be added to the standard weights of the respective basic model (cooling only and heat pump).**

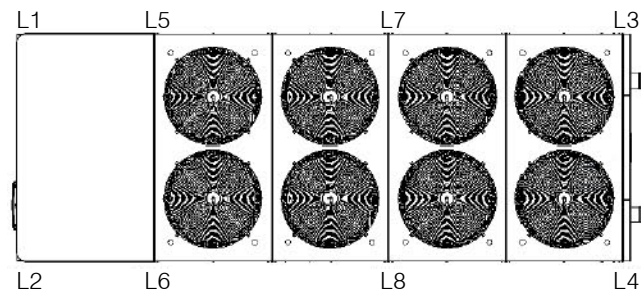

All weights stated below include the refrigerant charge as well as the water contained in the circuit (very important when assessing the most suitable bearing surface for the unit (especially in the presence of a tank). To get an approximate estimate of the unit's weight when empty, subtract the weight (in kg) of the water contained in the tank (see tables).

In other cases the water content is negligible for these purposes.

Frame	Lenght	Width	Height	Tank water content (kg)
1	2090	1183	1735	200
2	2440	1183	1735	220
3	3190	1183	1735	340
3 +	3540	1183	1735	340
4	3540	1653	1823	600
5	3540	1653	2223	600
6	4206	1653	2223	765

**Tab.23- Operating weight of LCE-C water chiller without hydraulic options**

<b>Model</b>	<b>042</b>	<b>052</b>	<b>062</b>	<b>062</b>	<b>072</b>	<b>072</b>	<b>082</b>	<b>082</b>	<b>091-092</b>	<b>091-092</b>	<b>101-102</b>		
<b>Version</b>	CS-CL-CQ	CS-CL-CQ	CS	CL-CQ	CS	CL-CQ	CS	CL-CQ	CS	CL-CQ	CS		
<b>Frame</b>	1	1	1	2	1	2	1	2	2	3	2		
<b>Total (kg)</b>	<b>525</b>	<b>525</b>	<b>540</b>	<b>630</b>	<b>570</b>	<b>635</b>	<b>650</b>	<b>700</b>	<b>730</b>	<b>905</b>	<b>730</b>		
<b>Distribution on resting points (kg)</b>	<b>L1</b>	197	197	203	236	214	238	244	263	274	170	274	
	<b>L2</b>	197	197	203	236	214	238	244	263	274	170	274	
	<b>L3</b>	66	66	68	79	71	79	81	88	91	113	91	
	<b>L4</b>	66	66	68	79	71	79	81	88	91	113	91	
	<b>L5</b>	-	-	-	-	-	-	-	-	-	-	170	-
	<b>L6</b>	-	-	-	-	-	-	-	-	-	-	170	-
	<b>L7</b>	-	-	-	-	-	-	-	-	-	-	-	-
	<b>L8</b>	-	-	-	-	-	-	-	-	-	-	-	-
<b>Model</b>	<b>101-102</b>	<b>121-122</b>	<b>141-142</b>	<b>161-162</b>	<b>094-104</b>	<b>124</b>	<b>144</b>	<b>164</b>	<b>121-122</b>	<b>124</b>	<b>141-142</b>		
<b>Version</b>	CL-CQ	CS	CS	CS	CL-CQ	CS	CS	CS	CL-CQ	CL-CQ	CL-CQ		
<b>Frame</b>	3	3	3	3	3 +	3 +	3 +	3 +	4	4	4		
<b>Total (kg)</b>	<b>915</b>	<b>1010</b>	<b>1055</b>	<b>1085</b>	<b>980</b>	<b>1050</b>	<b>1070</b>	<b>1220</b>	<b>1260</b>	<b>1275</b>	<b>1310</b>		
<b>Distribution on resting points (kg)</b>	<b>L1</b>	172	189	198	203	147	158	161	183	189	191	197	
	<b>L2</b>	172	189	198	203	147	158	161	183	189	191	197	
	<b>L3</b>	114	126	132	136	98	105	107	122	126	128	131	
	<b>L4</b>	114	126	132	136	98	105	107	122	126	128	131	
	<b>L5</b>	172	189	198	203	147	158	161	183	189	191	197	
	<b>L6</b>	172	189	198	203	147	158	161	183	189	191	197	
	<b>L7</b>	-	-	-	-	98	105	107	122	126	128	131	
	<b>L8</b>	-	-	-	-	98	105	107	122	126	128	131	
<b>Model</b>	<b>144</b>	<b>161-162</b>	<b>164</b>	<b>174</b>	<b>194</b>	<b>214</b>	<b>214</b>	<b>244</b>	<b>274</b>	<b>294</b>	<b>324</b>		
<b>Version</b>	CL-CQ	CL-CQ	CL-CQ	CS	CS-CL-CQ	CS	CL-CQ	CS-CL-CQ	CS-CL-CQ	CS-CL-CQ	CS-CL-CQ		
<b>Frame</b>	4	4	4	4	4	4	5	5	6	6	6		
<b>Total (kg)</b>	<b>1290</b>	<b>1330</b>	<b>1440</b>	<b>1440</b>	<b>1460</b>	<b>1470</b>	<b>1510</b>	<b>1620</b>	<b>1880</b>	<b>1912</b>	<b>1947</b>		
<b>Distribution on resting points (kg)</b>	<b>L1</b>	194	200	216	216	219	221	227	243	353	359	365	
	<b>L2</b>	194	200	216	216	219	221	227	243	353	359	365	
	<b>L3</b>	129	133	144	144	146	147	151	162	235	239	243	
	<b>L4</b>	129	133	144	144	146	147	151	162	235	239	243	
	<b>L5</b>	194	200	216	216	219	221	227	243	353	359	365	
	<b>L6</b>	194	200	216	216	219	221	227	243	353	359	365	
	<b>L7</b>	129	133	144	144	146	147	151	162	-	-	-	
	<b>L8</b>	129	133	144	144	146	147	151	162	-	-	-	

# Unit Weights



This drawing shows the points of the machine for which weights have been calculated, with respect to the basic chiller and heat pump model. The weights are shown in the tables below.

**Important note: the weights of the hydronic modules must be added to the standard weights of the respective basic model (cooling only and heat pump).**

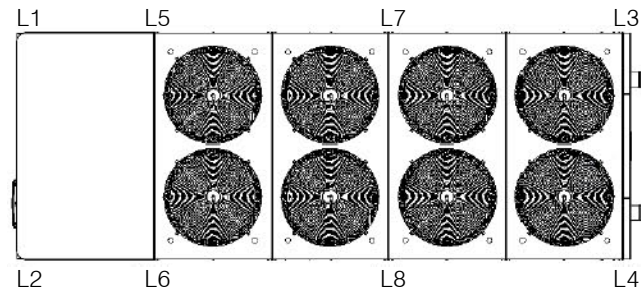

All weights stated below include the refrigerant charge as well as the water contained in the circuit (very important when assessing the most suitable bearing surface for the unit (especially in the presence of a tank). To get an approximate estimate of the unit's weight when empty, subtract the weight (in kg) of the water contained in the tank (see tables).

In other cases the water content is negligible for these purposes.

Frame	Lenght	Width	Height	Tank water content (kg)
1	2090	1183	1735	200
2	2440	1183	1735	220
3	3190	1183	1735	340
3 +	3540	1183	1735	340
4	3540	1653	1823	600
5	3540	1653	2223	600
6	4206	1653	2223	765

**Tab.24- Operating weight of LCE-H heat pumps without hydraulic options**

Model	042	052	062	062	072	072	082	082	091-092	091-092	101-102	
Version	HS-HL-HQ	HS-HL-HQ	HS	HL-HQ	HS	HL-HQ	HS	HL-HQ	HS	HL-HQ	HS	
Frame	1	1	1	2	1	2	1	2	2	3	2	
Total (kg)	545	545	585	650	585	655	675	735	755	940	760	
Distribution on resting points (kg)	L1	204	204	219	244	219	246	253	276	283	176	285
	L2	204	204	219	244	219	246	253	276	283	176	285
	L3	68	68	73	81	73	82	84	92	94	118	95
	L4	68	68	73	81	73	82	84	92	94	118	95
	L5	-	-	-	-	-	-	-	-	-	176	-
	L6	-	-	-	-	-	-	-	-	-	176	-
	L7	-	-	-	-	-	-	-	-	-	-	-
	L8	-	-	-	-	-	-	-	-	-	-	-
Model	101-102	121-122	141-142	161-162	094-104	124	144	164	121-122	124	141-142	
Version	HL-HQ	HS	HS	HS	HL-HQ	HS	HS	HS	HL-HQ	HL-HQ	HL-HQ	
Frame	3	3	3	3	3 +	3 +	3 +	3 +	4	4	4	
Total (kg)	945	1050	1100	1155	1020	1090	1120	1270	1305	1315	1350	
Distribution on resting points (kg)	L1	177	197	206	217	153	164	168	191	196	197	203
	L2	177	197	206	217	153	164	168	191	196	197	203
	L3	118	131	138	144	102	109	112	127	131	132	135
	L4	118	131	138	144	102	109	112	127	131	132	135
	L5	177	197	206	217	153	164	168	191	196	197	203
	L6	177	197	206	217	153	164	168	191	196	197	203
	L7	-	-	-	-	102	109	112	127	131	132	135
	L8	-	-	-	-	102	109	112	127	131	132	135
Model	144	161-162	164	174	194	214	214	244	274	294	324	
Version	HL-HQ	HL-HQ	HL-HQ	HS	HS-HL-HQ	HS	HL-HQ	HS-HL-HQ	HS-HL-HQ	HS-HL-HQ	HS-HL-HQ	
Frame	4	4	4	4	4	4	5	5	6	6	6	
Total (kg)	1345	1375	1495	1495	1515	1530	1590	1690	1952	1987	2038	
Distribution on resting points (kg)	L1	202	206	224	224	227	230	239	254	366	373	382
	L2	202	206	224	224	227	230	239	254	366	373	382
	L3	135	138	150	150	152	153	159	169	244	248	255
	L4	135	138	150	150	152	153	159	169	244	248	255
	L5	202	206	224	224	227	230	239	254	366	373	382
	L6	202	206	224	224	227	230	239	254	366	373	382
	L7	135	138	150	150	152	153	159	169	-	-	-
	L8	135	138	150	150	152	153	159	169	-	-	-

# Unit Weights



This drawing shows the points of the machine for which weights have been calculated, with respect to the basic chiller and heat pump model. The weights are shown in the tables below.

**Important note: the weights of the hydronic modules must be added to the standard weights of the respective basic model (cooling only and heat pump).**

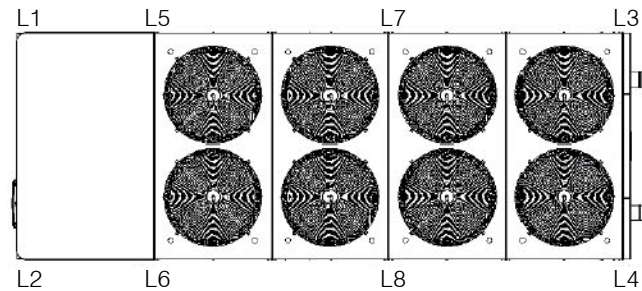

All weights stated below include the refrigerant charge as well as the water contained in the circuit (very important when assessing the most suitable bearing surface for the unit (especially in the presence of a tank). To get an approximate estimate of the unit's weight when empty, subtract the weight (in kg) of the water contained in the tank (see tables).

In other cases the water content is negligible for these purposes.

Frame	Lenght	Width	Height	Tank water content (kg)
1	2090	1183	1735	200
2	2440	1183	1735	220
3	3190	1183	1735	340
3 +	3540	1183	1735	340
4	3540	1653	1823	600
5	3540	1653	2223	600
6	4206	1653	2223	765

**Tab.25- Weight of hydronic modules: 1 pump (add to weight of unit)**

Model	042	052	062	062	072	072	082	082	091-092	091-092	101-102	
Version	S-L-Q	S-L-Q	S	L-Q	S	L-Q	S	L-Q	S	L-Q	S	
Frame	1	1	1	2	1	2	1	2	2	3	2	
Total (kg)	116	116	116	148	116	148	116	134	143	159	143	
Distribution on resting points (kg)	L1	29	29	29	37	29	37	29	33	36	8	36
	L2	29	29	29	37	29	37	29	33	36	8	36
	L3	29	29	29	37	29	37	29	33	36	36	36
	L4	29	29	29	37	29	37	29	33	36	36	36
	L5	-	-	-	-	-	-	-	-	-	36	-
	L6	-	-	-	-	-	-	-	-	-	36	-
	L7	-	-	-	-	-	-	-	-	-	-	-
	L8	-	-	-	-	-	-	-	-	-	-	-
Model	101-102	121-122	141-142	161-162	094-104	124	144	164	121-122	124	141-142	
Version	L-Q	S	S	S	L-Q	S	S	S	L-Q	L-Q	L-Q	
Frame	3	3	3	3	3 +	3 +	3 +	3 +	4	4	4	
Total (kg)	159	159	159	159	142,5	159	159	159	165	165	165	
Distribution on resting points (kg)	L1	8	8	8	8	0	0	0	0	0	0	0
	L2	8	8	8	8	0	0	0	0	0	0	0
	L3	36	36	36	36	21	24	24	24	25	25	25
	L4	36	36	36	36	21	24	24	24	25	25	25
	L5	36	36	36	36	21	24	24	24	25	25	25
	L6	36	36	36	36	21	24	24	24	25	25	25
	L7	-	-	-	-	29	32	32	32	33	33	33
	L8	-	-	-	-	29	32	32	32	33	33	33
Model	144	161-162	164	174	194	214	214	244	274	294	324	
Version	L-Q	L-Q	L-Q	S	S-L-Q	S	L-Q	S-L-Q	S-L-Q	S-L-Q	S-L-Q	
Frame	4	4	4	4	4	4	5	5	6	6	6	
Total (kg)	165	165	165	177	177	177	177	186	186	186	186	
Distribution on resting points (kg)	L1	0	0	0	0	0	0	0	31	31	31	
	L2	0	0	0	0	0	0	0	31	31	31	
	L3	25	25	25	27	27	27	27	28	31	31	31
	L4	25	25	25	27	27	27	27	28	31	31	31
	L5	25	25	25	27	27	27	27	28	31	31	31
	L6	25	25	25	27	27	27	27	28	31	31	31
	L7	33	33	33	35	35	35	35	37	-	-	-
	L8	33	33	33	35	35	35	35	37	-	-	-

# Unit Weights



This drawing shows the points of the machine for which weights have been calculated, with respect to the basic chiller and heat pump model. The weights are shown in the tables below.

**Important note: the weights of the hydronic modules must be added to the standard weights of the respective basic model (cooling only and heat pump).**

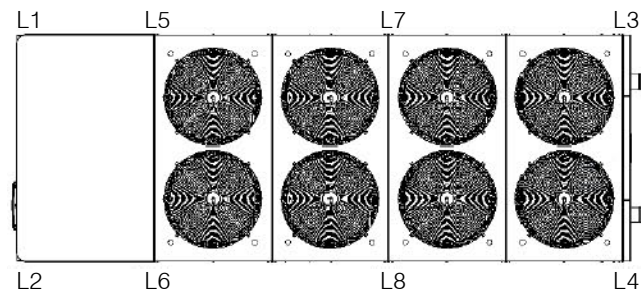

All weights stated below include the refrigerant charge as well as the water contained in the circuit (very important when assessing the most suitable bearing surface for the unit (especially in the presence of a tank). To get an approximate estimate of the unit's weight when empty, subtract the weight (in kg) of the water contained in the tank (see tables).

In other cases the water content is negligible for these purposes.

Frame	Lenght	Width	Height	Tank water content (kg)
1	2090	1183	1735	200
2	2440	1183	1735	220
3	3190	1183	1735	340
3 +	3540	1183	1735	340
4	3540	1653	1823	600
5	3540	1653	2223	600
6	4206	1653	2223	765

**Tab.26- Weight of hydronic modules: 2 pumps (add to weight of unit)**

Model	042	052	062	062	072	072	082	082	091-092	091-092	101-102	
Version	S-L-Q	S-L-Q	S	L-Q	S	L-Q	S	L-Q	S	L-Q	S	
Frame	1	1	1	2	1	2	1	2	2	3	2	
Total (kg)	154	154	154	197	154	197	154	178	190	212	190	
Distribution on resting points (kg)	L1	39	39	39	49	39	49	39	45	48	11	48
	L2	39	39	39	49	39	49	39	45	48	11	48
	L3	39	39	39	49	39	49	39	45	48	48	48
	L4	39	39	39	49	39	49	39	45	48	48	48
	L5	-	-	-	-	-	-	-	-	-	48	-
	L6	-	-	-	-	-	-	-	-	-	48	-
	L7	-	-	-	-	-	-	-	-	-	-	-
	L8	-	-	-	-	-	-	-	-	-	-	-
Model	101-102	121-122	141-142	161-162	094-104	124	144	164	121-122	124	141-142	
Version	L-Q	S	S	S	L-Q	S	S	S	L-Q	L-Q	L-Q	
Frame	3	3	3	3	3 +	3 +	3 +	3 +	4	4	4	
Total (kg)	212	212	212	212	190	212	212	212	220	220	220	
Distribution on resting points (kg)	L1	11	11	11	11	0	0	0	0	0	0	0
	L2	11	11	11	11	0	0	0	0	0	0	0
	L3	48	48	48	48	29	32	32	32	33	33	33
	L4	48	48	48	48	29	32	32	32	33	33	33
	L5	48	48	48	48	29	32	32	32	33	33	33
	L6	48	48	48	48	29	32	32	32	33	33	33
	L7	-	-	-	-	38	42	42	42	44	44	44
	L8	-	-	-	-	38	42	42	42	44	44	44
Model	144	161-162	164	174	194	214	214	244	274	294	324	
Version	L-Q	L-Q	L-Q	S	S-L-Q	S	L-Q	S-L-Q	S-L-Q	S-L-Q	S-L-Q	
Frame	4	4	4	4	4	4	5	5	6	6	6	
Total (kg)	220	220	220	236	236	236	236	248	248	248	248	
Distribution on resting points (kg)	L1	0	0	0	0	0	0	0	41	41	41	
	L2	0	0	0	0	0	0	0	41	41	41	
	L3	33	33	33	35	35	35	35	37	41	41	41
	L4	33	33	33	35	35	35	35	37	41	41	41
	L5	33	33	33	35	35	35	35	37	41	41	41
	L6	33	33	33	35	35	35	35	37	41	41	41
	L7	44	44	44	47	47	47	47	50	-	-	-
	L8	44	44	44	47	47	47	47	50	-	-	-



# Unit Weights



This drawing shows the points of the machine for which weights have been calculated, with respect to the basic chiller and heat pump model. The weights are shown in the tables below.

**Important note: the weights of the hydronic modules must be added to the standard weights of the respective basic model (cooling only and heat pump).**

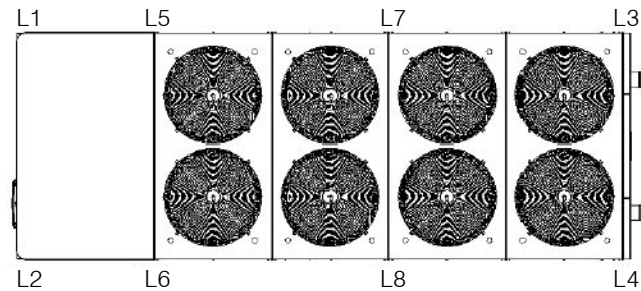

All weights stated below include the refrigerant charge as well as the water contained in the circuit (very important when assessing the most suitable bearing surface for the unit (especially in the presence of a tank). To get an approximate estimate of the unit's weight when empty, subtract the weight (in kg) of the water contained in the tank (see tables).

In other cases the water content is negligible for these purposes.

Frame	Lenght	Width	Height	Tank water content (kg)
1	2090	1183	1735	200
2	2440	1183	1735	220
3	3190	1183	1735	340
3 +	3540	1183	1735	340
4	3540	1653	1823	600
5	3540	1653	2223	600
6	4206	1653	2223	765

**Tab.27- Weight of hydronic modules: 1 pump + Full buffer tank (add to weight of unit)**

Model	042	052	062	062	072	072	082	082	091-092	091-092	101-102	
Version	S-L-Q	S-L-Q	S	L-Q	S	L-Q	S	L-Q	S	L-Q	S	
Frame	1	1	1	2	1	2	1	2	2	3	2	
Total (kg)	337	337	337	352	337	352	337	367	408	521	408	
Distribution on resting points (kg)	L1	84	84	84	88	84	88	84	92	102	26	102
	L2	84	84	84	88	84	88	84	92	102	26	102
	L3	84	84	84	88	84	88	84	92	102	117	102
	L4	84	84	84	88	84	88	84	92	102	117	102
	L5	-	-	-	-	-	-	-	-	-	117	-
	L6	-	-	-	-	-	-	-	-	-	117	-
	L7	-	-	-	-	-	-	-	-	-	-	-
	L8	-	-	-	-	-	-	-	-	-	-	-
Model	101-102	121-122	141-142	161-162	094-104	124	144	164	121-122	124	141-142	
Version	L-Q	S	S	S	L-Q	S	S	S	L-Q	L-Q	L-Q	
Frame	3	3	3	3	3 +	3 +	3 +	3 +	4	4	4	
Total (kg)	521	571	571	571	577,5	591	591	591	780	780	780	
Distribution on resting points (kg)	L1	26	29	29	29	-	-	-	-	-	-	-
	L2	26	29	29	29	-	-	-	-	-	-	-
	L3	117	128	128	128	87	89	89	89	117	117	117
	L4	117	128	128	128	87	89	89	89	117	117	117
	L5	117	128	128	128	87	89	89	89	117	117	117
	L6	117	128	128	128	87	89	89	89	117	117	117
	L7	-	-	-	-	116	118	118	118	156	156	156
	L8	-	-	-	-	116	118	118	118	156	156	156
Model	144	161-162	164	174	194	214	214	244	274	294	324	
Version	L-Q	L-Q	L-Q	S	S-L-Q	S	L-Q	S-L-Q	S-L-Q	S-L-Q	S-L-Q	
Frame	4	4	4	4	4	4	5	5	6	6	6	
Total (kg)	780	780	780	768	816	816	816	849	1014	1014	1014	
Distribution on resting points (kg)	L1	-	-	-	-	-	-	-	169	169	169	
	L2	-	-	-	-	-	-	-	169	169	169	
	L3	117	117	117	115	122	122	122	127	169	169	
	L4	117	117	117	115	122	122	122	127	169	169	
	L5	117	117	117	115	122	122	122	127	169	169	
	L6	117	117	117	115	122	122	122	127	169	169	
	L7	156	156	156	154	163	163	163	170	-	-	
	L8	156	156	156	154	163	163	163	170	-	-	

# Unit Weights



This drawing shows the points of the machine for which weights have been calculated, with respect to the basic chiller and heat pump model. The weights are shown in the tables below.

**Important note: the weights of the hydronic modules must be added to the standard weights of the respective basic model (cooling only and heat pump).**

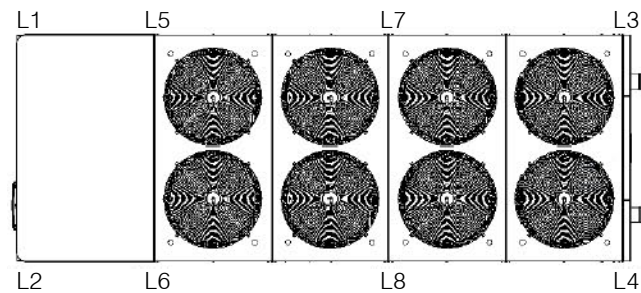

All weights stated below include the refrigerant charge as well as the water contained in the circuit (very important when assessing the most suitable bearing surface for the unit (especially in the presence of a tank). To get an approximate estimate of the unit's weight when empty, subtract the weight (in kg) of the water contained in the tank (see tables).

In other cases the water content is negligible for these purposes.

Frame	Lenght	Width	Height	Tank water content (kg)
1	2090	1183	1735	200
2	2440	1183	1735	220
3	3190	1183	1735	340
3 +	3540	1183	1735	340
4	3540	1653	1823	600
5	3540	1653	2223	600
6	4206	1653	2223	765

**Tab.28- Weight of hydronic modules: 2 pumps + Full buffer tank (add to weight of unit)**

Model	042	052	062	062	072	072	082	082	091-092	091-092	101-102	
Version	S-L-Q	S-L-Q	S	L-Q	S	L-Q	S	L-Q	S	L-Q	S	
Frame	1	1	1	2	1	2	1	2	2	3	2	
Total (kg)	402	402	402	450	402	450	402	450	500	630	500	
Distribution on resting points (kg)	L1	101	101	101	113	101	113	101	113	125	32	125
	L2	101	101	101	113	101	113	101	113	125	32	125
	L3	101	101	101	113	101	113	101	113	125	142	125
	L4	101	101	101	113	101	113	101	113	125	142	125
	L5	-	-	-	-	-	-	-	-	-	142	-
	L6	-	-	-	-	-	-	-	-	-	142	-
	L7	-	-	-	-	-	-	-	-	-	-	-
	L8	-	-	-	-	-	-	-	-	-	-	-
Model	101-102	121-122	141-142	161-162	094-104	124	144	164	121-122	124	141-142	
Version	L-Q	S	S	S	L-Q	S	S	S	L-Q	L-Q	L-Q	
Frame	3	3	3	3	3 +	3 +	3 +	3 +	4	4	4	
Total (kg)	630	660	660	660	650	680	680	680	875	875	875	
Distribution on resting points (kg)	L1	32	33	33	33	-	-	-	-	-	-	
	L2	32	33	33	33	-	-	-	-	-	-	
	L3	142	149	149	149	98	102	102	102	131	131	
	L4	142	149	149	149	98	102	102	102	131	131	
	L5	142	149	149	149	98	102	102	102	131	131	
	L6	142	149	149	149	98	102	102	102	131	131	
	L7	-	-	-	-	130	136	136	136	175	175	
	L8	-	-	-	-	130	136	136	136	175	175	
Model	144	161-162	164	174	194	214	214	244	274	294	324	
Version	L-Q	L-Q	L-Q	S	S-L-Q	S	L-Q	S-L-Q	S-L-Q	S-L-Q	S-L-Q	
Frame	4	4	4	4	4	4	5	5	6	6	6	
Total (kg)	875	875	875	875	908	908	908	950	1115	1115	1115	
Distribution on resting points (kg)	L1	-	-	-	-	-	-	-	186	186	186	
	L2	-	-	-	-	-	-	-	186	186	186	
	L3	131	131	131	131	136	136	136	143	186	186	
	L4	131	131	131	131	136	136	136	143	186	186	
	L5	131	131	131	131	136	136	136	143	186	186	
	L6	131	131	131	131	136	136	136	143	186	186	
	L7	175	175	175	175	182	182	182	190	-	-	
	L8	175	175	175	175	182	182	182	190	-	-	





**LCE-0-PD-GB-01 - 18.06.2010**

All rights reserved.

No part of this publication may be reproduced without prior written permission from LENNOX.

LENNOX reserves the right to make changes in specifications and other information contained in this manual without prior notice. In no event shall LENNOX be liable for any incidental, special, indirect, or consequential damages whatsoever, including but not limited to lost profits, arising out of or related to this manual or the information contained herein, even if LENNOX has been advised of, known, or should have known, the possibility of such damages.